



**Final  
Hanford Site Solid  
(Radioactive and Hazardous)  
Waste Program  
Environmental Impact  
Statement  
Richland, Washington**

**Volume I  
Sections 1 through 7**

U.S. Department of Energy  
Richland Operations Office  
Richland, Washington

**Cover Photographs:**

- 1. Hanford workers preparing to retrieve and repackage TRU waste drums**
- 2. Drums of transuranic waste in a retrievable storage trench**
- 3. A partial aerial view of Hanford's Low Level Burial Grounds**
- 4. Waste Receiving and Processing Facility inspection and repackaging glove boxes**
- 5. Hanford's Mixed Low-Level Waste disposal facility**
- 6. Placing TRU waste into a TRUPACT shipping container for shipment to the Waste Isolation Pilot Plant**

**RESPONSIBLE AGENCY:**

U.S. Department of Energy, Richland Operations Office

**COVER SHEET****TITLE:**

Final Hanford Site Solid (Radioactive and Hazardous) Waste Program Environmental Impact Statement, Richland, Benton County, Washington (DOE/EIS-0286F)

**CONTACT:**

For further information on this document, write or call:

Mr. Michael S. Collins  
HSW EIS Document Manager  
Richland Operations Office  
U.S. Department of Energy, A6-38  
P.O. Box 550  
Richland, Washington 99352-0550  
Telephone: (509) 376-6536  
Fax: (509) 372-1926  
Email: hsweis@rl.gov

For further information on the Department's National Environmental Policy Act (NEPA) process, contact:

Ms. Carol M. Borgstrom, Director  
Office of NEPA Policy and Compliance, EH-42  
U.S. Department of Energy  
1000 Independence Avenue, S.W.  
Washington, D.C. 20585  
Telephone: (202) 586-4600  
Voice Mail: (800) 472-2756

**ABSTRACT:**

The Hanford Site Solid (Radioactive and Hazardous) Waste Program Environmental Impact Statement (HSW EIS) provides environmental and technical information concerning U.S. Department of Energy (DOE) proposed waste management practices at the Hanford Site. The HSW EIS updates analyses of environmental consequences from previous documents and provides evaluations for activities that may be implemented consistent with the Waste Management Programmatic Environmental Impact Statement (WM PEIS) Records of Decision (RODs). Waste types considered in the HSW EIS include operational low-level radioactive waste (LLW), mixed low-level waste (MLLW), immobilized low-activity waste (ILAW), and transuranic (TRU) waste (including TRU mixed waste). MLLW contains chemically hazardous components in addition to radionuclides. Alternatives for management of these wastes at the Hanford Site, including the alternative of No Action, are analyzed in detail. The LLW, MLLW, and TRU waste alternatives are evaluated for a range of waste volumes, representing quantities of waste that could be managed at the Hanford Site. A single maximum forecast volume is evaluated for ILAW. The No Action Alternative considers continuation of ongoing waste management practices at the Hanford Site and ceasing some operations when the limits of existing capabilities are reached. The No Action Alternative provides for continued storage of some waste types. The other alternatives evaluate expanded waste management practices including treatment and disposal of most wastes. The potential environmental consequences of the alternatives are generally similar. The major differences occur with respect to the consequences of disposal versus continued storage and with respect to the range of waste volumes managed under the alternatives. DOE's preferred alternative is to dispose of LLW, MLLW, and ILAW in a single, modular, lined facility near PUREX on Hanford's Central Plateau; to treat MLLW using a combination of onsite and offsite facilities; and to certify TRU waste onsite using a combination of existing, upgraded, and mobile facilities. DOE issued the Notice of Intent to prepare the HSW EIS on October 27, 1997, and held public meetings during the scoping period that extended through January 30, 1998. In April 2002, DOE issued the initial draft of the EIS. During the public comment period that extended from May through August 2002, DOE received numerous comments from regulators, tribal nations, and other stakeholders. In March 2003, DOE issued a revised draft of the HSW EIS to address those comments, and to incorporate disposal of ILAW and other alternatives that had been under consideration since the first draft was published. Comments on the revised draft were received from April 11 through June 11, 2003. This final EIS responds to comments on the revised draft and includes updated analyses to incorporate information developed since the revised draft was published. DOE will publish the ROD(s) in the *Federal Register* no sooner than 30 days after publication of the Environmental Protection Agency's Notice of Availability of the final HSW EIS.

# Contents

Cover Sheet	
Acronyms/Abbreviations .....	xxiv
Glossary of Terms.....	xxxii
Glossary of Terms Related to Radioactivity, Radiation Dose, and Exposure.....	xliv
Units of Measure.....	xlviii
Reference Citations.....	li
1.0 Introduction.....	1.1
1.1 Organization of the HSW EIS .....	1.2
1.2 Purpose and Need and Proposed Action .....	1.3
1.3 Overview of Hanford Site Operations and DOE Waste Management Activities.....	1.4
1.3.1 DOE National Waste Management .....	1.5
1.3.2 DOE Waste Management Activities at Hanford .....	1.9
1.4 Related Department of Energy Initiatives at the Hanford Site .....	1.14
1.4.1 EM Top-to-Bottom Review.....	1.14
1.4.2 DOE Cost Report .....	1.15
1.4.3 Cleanup, Constraints, and Challenges Team (C3T) .....	1.15
1.4.4 Hanford Performance Management Plan (HPMP).....	1.15
1.5 Relationship of the HSW EIS to Other Hanford and DOE NEPA Documents.....	1.16
1.5.1 Interim Actions During Preparation of the HSW EIS .....	1.16
1.5.2 Related NEPA Documents .....	1.18
1.5.3 Related State Environmental Policy Act (SEPA) Documents.....	1.30
1.5.4 Related CERCLA Documents.....	1.31
1.6 NEPA Process for the HSW EIS.....	1.31
1.6.1 Scoping for the Draft HSW EIS .....	1.32
1.6.2 Publication of the First Draft HSW EIS .....	1.32
1.6.3 Public Comments on the First Draft HSW EIS .....	1.33
1.6.4 Scoping for the ILAW Disposal SEIS.....	1.34
1.6.5 Revised Draft HSW EIS.....	1.35
1.6.6 Preparation of the Final HSW EIS and Record(s) of Decision .....	1.36
1.7 Scope of the HSW EIS .....	1.37
1.7.1 Waste Types Evaluated in the HSW EIS .....	1.37
1.7.2 Waste Volumes Evaluated in the HSW EIS.....	1.39
1.7.3 Hanford Waste Management Alternatives Evaluated in the HSW EIS.....	1.39
1.7.4 Environmental Impact Analyses in the HSW EIS.....	1.45
1.8 References .....	1.46
2.0 HSW EIS Waste Streams and Waste Management Facilities.....	2.1
2.1 Solid Waste Types and Waste Streams Related to the Proposed Action .....	2.1
2.1.1 LLW Streams .....	2.2
2.1.2 Mixed Low-Level Waste Streams.....	2.4



2.1.3	TRU Waste Streams .....	2.8
2.1.4	Waste Treatment Plant Wastes.....	2.11
2.2	Hanford Waste Storage, Treatment, and Disposal Facilities, and Transportation	
	Capabilities Related to the Proposed Action .....	2.12
2.2.1	Storage Facilities .....	2.12
2.2.2	Treatment and Processing Facilities.....	2.16
2.2.3	Disposal Facilities .....	2.24
2.2.4	Transportation .....	2.37
2.2.5	Pollution Prevention/Waste Minimization .....	2.40
2.2.6	Decontamination and Decommissioning of Hanford Facilities .....	2.41
2.2.7	Long-Term Stewardship.....	2.41
2.3	References .....	2.42
3.0	Description and Comparison of Alternatives.....	3.1
3.1	Alternatives Considered in Detail and Their Development.....	3.1
3.1.1	No Action Alternative .....	3.6
3.1.2	Alternative Group A.....	3.7
3.1.3	Alternative Group B .....	3.9
3.1.4	Alternative Group C .....	3.10
3.1.5	Alternative Group D.....	3.11
3.1.6	Alternative Group E .....	3.11
3.1.7	Summary Tables of Alternative Groups.....	3.12
3.2	Alternatives Considered but Not Evaluated in Detail .....	3.12
3.2.1	Storage Options .....	3.12
3.2.2	Treatment Options.....	3.15
3.2.3	Disposal Options .....	3.16
3.2.4	Stop Work Scenario.....	3.17
3.3	Volumes of Waste Considered in Each Alternative .....	3.18
3.3.1	LLW Volumes.....	3.19
3.3.2	MLLW Volumes .....	3.19
3.3.3	TRU Waste Volumes.....	3.20
3.3.4	Waste Treatment Plant Waste Volumes .....	3.21
3.4	Comparison of Environmental Impacts Among the Alternatives .....	3.21
3.4.1	Land Use .....	3.25
3.4.2	Air Quality.....	3.26
3.4.3	Water Quality .....	3.27
3.4.4	Geologic Resources .....	3.36
3.4.5	Ecological Resources .....	3.36
3.4.6	Socioeconomics and Environmental Justice .....	3.36
3.4.7	Cultural, Aesthetic, and Scenic Resources .....	3.37
3.4.8	Transportation .....	3.37
3.4.9	Noise.....	3.39
3.4.10	Resource Commitments .....	3.39

3.4.11	Human Health and Safety.....	3.39
3.4.12	Cumulative Impacts.....	3.43
3.5	Areas of Uncertainty, Incomplete, or Unavailable Information.....	3.54
3.5.1	Waste Volumes .....	3.55
3.5.2	Waste Inventories of Radioactive Materials.....	3.56
3.5.3	Waste Inventories of Non-Radioactive Hazardous Materials .....	3.56
3.5.4	Release, Fate, and Transport of Radioactive and Hazardous Materials .....	3.58
3.5.5	Human and Ecological Risk Associated with Exposure to Radioactive and Hazardous Materials.....	3.60
3.5.6	Technical Maturity of Alternative Treatment Processes .....	3.60
3.5.7	Timing of Activities Evaluated in the Alternative Groups.....	3.61
3.6	Costs of Alternatives .....	3.62
3.7	DOE Preferred Alternative .....	3.63
3.8	References .....	3.64
4.0	Affected Environment.....	4.1
4.1	Introduction .....	4.1
4.2	Land Use .....	4.3
4.2.1	Hanford Reach National Monument .....	4.6
4.2.2	200 Areas.....	4.7
4.3	Meteorology and Air Quality .....	4.12
4.3.1	Climate and Meteorology.....	4.12
4.3.2	Atmospheric Dispersion.....	4.20
4.3.3	Air Quality.....	4.21
4.3.4	Background Radiation.....	4.24
4.4	Geologic Resources.....	4.25
4.4.1	Topography and Geomorphology .....	4.25
4.4.2	Stratigraphy .....	4.26
4.4.3	Soils.....	4.30
4.4.4	Seismicity .....	4.30
4.5	Hydrology.....	4.36
4.5.1	Surface Water.....	4.36
4.5.2	Hanford Site Vadose Zone .....	4.40
4.5.3	Groundwater.....	4.44
4.6	Biological and Ecological Resources .....	4.55
4.6.1	Vegetation .....	4.56
4.6.2	Wildlife.....	4.63
4.6.3	Aquatic Ecology .....	4.67
4.6.4	Threatened and Endangered Species .....	4.68
4.6.5	Microbiotic Crusts.....	4.74
4.6.6	Biodiversity .....	4.75
4.7	Cultural, Archaeological, and Historical Resources.....	4.75
4.7.1	Native American Cultural Resources and Archaeological Resources.....	4.75
4.7.2	Historic Archaeological Resources .....	4.77

4.7.3	Historic Built Environment .....	4.78
4.7.4	200 Areas.....	4.79
4.8	Socioeconomic Activity .....	4.81
4.8.1	Local Economy .....	4.81
4.8.2	Environmental Justice .....	4.83
4.8.3	Demography .....	4.89
4.8.4	Housing .....	4.89
4.8.5	Traffic and Transportation.....	4.89
4.8.6	Educational Services .....	4.94
4.8.7	Health Care and Human Services.....	4.94
4.8.8	Police and Fire Protection .....	4.95
4.8.9	Utilities .....	4.95
4.8.10	Aesthetic and Scenic Resources .....	4.96
4.9	Noise.....	4.96
4.10	Occupational Safety .....	4.98
4.11	Occupational Radiation Exposure at the Hanford Site.....	4.99
4.12	References .....	4.103
5.0	Environmental Consequences.....	5.1
5.1	Land Use .....	5.8
5.2	Air Quality.....	5.16
5.2.1	Alternative Group A.....	5.19
5.2.2	Alternative Group B .....	5.21
5.2.3	Alternative Group C.....	5.22
5.2.4	Alternative Groups D <sub>1</sub> , D <sub>2</sub> , and D <sub>3</sub> .....	5.23
5.2.5	Alternative Groups E <sub>1</sub> , E <sub>2</sub> , and E <sub>3</sub> .....	5.25
5.2.6	No Action Alternative .....	5.25
5.2.7	Comparison of the Alternative Groups .....	5.27
5.3	Water Quality.....	5.30
5.3.1	Potential Short-Term Impacts of Operations and Construction Activities.....	5.30
5.3.2	Methods for Assessment of Potential Long-Term Impacts .....	5.31
5.3.3	Use of ILAW Performance Assessment Calculations to Support the HSW EIS .....	5.40
5.3.4	Potential Long-Term Impacts on Groundwater Quality.....	5.41
5.3.5	Effect of Long-Term Cover System Performance Assumptions.....	5.75
5.3.6	Potential Groundwater Quality Impacts at Waste Management Area Boundaries for Selected Alternatives .....	5.78
5.3.7	Potential Groundwater Quality Impacts from Hazardous Chemicals in Pre-1988 Wastes.....	5.91
5.4	Geologic Resources .....	5.96
5.5	Ecological Resources .....	5.97
5.5.1	Alternative Group A.....	5.98
5.5.2	Alternative Group B .....	5.102
5.5.3	Alternative Group C .....	5.103

5.5.4	Alternative Group D <sub>1</sub> .....	5.104
5.5.5	Alternative Group D <sub>2</sub> .....	5.105
5.5.6	Alternative Group D <sub>3</sub> .....	5.105
5.5.7	Alternative Group E <sub>1</sub> .....	5.107
5.5.8	Alternative Group E <sub>2</sub> .....	5.107
5.5.9	Alternative Group E <sub>3</sub> .....	5.108
5.5.10	No Action Alternative.....	5.109
5.5.11	Microbiotic Crusts.....	5.110
5.5.12	Threatened or Endangered Species.....	5.111
5.5.13	Potential Impacts on Columbia River Aquatic and Riparian Biota in the Long Term.....	5.112
5.6	Socioeconomics.....	5.114
5.6.1	Alternative Group A.....	5.117
5.6.2	Alternative Group B.....	5.119
5.6.3	Alternative Group C.....	5.121
5.6.4	Alternative Group D.....	5.121
5.6.5	Alternative Group E.....	5.124
5.6.6	No Action Alternative.....	5.124
5.7	Cultural Resources Impacts.....	5.126
5.7.1	Alternative Group A.....	5.127
5.7.2	Alternative Group B.....	5.128
5.7.3	Alternative Group C.....	5.128
5.7.4	Alternative Group D.....	5.129
5.7.5	Alternative Group E.....	5.129
5.7.6	No Action Alternative.....	5.129
5.8	Traffic and Transportation.....	5.131
5.9	Noise.....	5.147
5.9.1	Alternative Group A.....	5.148
5.9.2	Alternative Group B.....	5.149
5.9.3	Alternative Group C.....	5.150
5.9.4	Alternative Groups D and E.....	5.150
5.9.5	No Action Alternative.....	5.150
5.10	Resource Commitments.....	5.151
5.11	Human Health and Safety Impacts.....	5.154
5.11.1	Operational Human Health and Safety Impacts.....	5.158
5.11.2	Long-Term Human Health and Safety Impacts.....	5.217
5.12	Aesthetic and Scenic Resources.....	5.270
5.12.1	Alternative Group A.....	5.271
5.12.2	Alternative Group B.....	5.271
5.12.3	Alternative Group C.....	5.272
5.12.4	Alternative Group D.....	5.272
5.12.5	Alternative Group E.....	5.273
5.12.6	No Action Alternative.....	5.273

5.13	Environmental Justice .....	5.275
5.14	Cumulative Impacts.....	5.277
5.14.1	Land Use .....	5.279
5.14.2	Air Quality.....	5.279
5.14.3	Ecological, Cultural, Aesthetic, and Scenic Resources .....	5.280
5.14.4	Geologic Resources.....	5.281
5.14.5	Socioeconomics.....	5.282
5.14.6	Public Health .....	5.283
5.14.7	Worker Health and Safety .....	5.299
5.15	Irreversible and Irretrievable Commitments of Resources.....	5.300
5.16	Relationship Between Short-Term Uses of the Environment and the Maintenance or Enhancement of Long-Term Productivity .....	5.302
5.17	Unavoidable Adverse Impacts.....	5.303
5.17.1	Alternative Group A.....	5.303
5.17.2	Alternative Group B .....	5.304
5.17.3	Alternative Group C .....	5.304
5.17.4	Alternative Groups D and E (All Subalternatives).....	5.304
5.17.5	No Action Alternative .....	5.304
5.18	Potential Mitigation Measures.....	5.306
5.18.1	Pollution Prevention/Waste Minimization .....	5.306
5.18.2	Cultural Resources .....	5.307
5.18.3	Ecological Resources .....	5.307
5.18.4	Water Quality .....	5.308
5.18.5	Health and Safety – Routine Operations .....	5.308
5.18.6	Health and Safety – Accidents .....	5.309
5.18.7	Traffic and Transportation.....	5.309
5.18.8	Area and Resource Management and Mitigation Plans .....	5.310
5.18.9	Long-Term Stewardship and Post Closure.....	5.312
5.19	References .....	5.313
6.0	Regulatory Framework .....	6.1
6.1	Potentially Applicable Statutes .....	6.1
6.1.1	Federal Statutes .....	6.1
6.1.2	Washington State Statutes .....	6.6
6.2	Land-Use Management.....	6.8
6.3	Hanford Federal Facility Agreement and Consent Order .....	6.9
6.4	Hazardous Waste Management.....	6.10
6.5	Radioactive Waste Management.....	6.11
6.6	Radiological Safety Oversight .....	6.12
6.7	Radiation Protection of the Public and the Environment.....	6.13
6.8	Occupational Safety and Occupational Radiation Exposure .....	6.15
6.9	Non-Radioactive Air Emissions .....	6.16
6.10	State Waste Discharge Requirements .....	6.16
6.11	Transportation Requirements.....	6.16



6.12 Cultural Resources .....	6.17
6.13 Treaties, Statutes, and Policies Relating to Native Americans .....	6.18
6.14 Environmental Justice and Protection of Children .....	6.20
6.15 Chemical Management .....	6.21
6.16 Emergency Planning and Community Right-to-Know .....	6.21
6.17 Pollution Prevention .....	6.21
6.18 Endangered Species .....	6.21
6.19 Permit Requirements.....	6.22
6.20 References.....	6.24
7.0 List of Preparers and Contributors .....	7.1
Index .....	Index.1
Distribution .....	Dist.1

# Figures

1.1	Hanford Site Location Map .....	1.4
1.2	States with Radioactive Waste Disposal Activities .....	1.6
1.3	Relationship of the HSW EIS to Other Hanford Cleanup Operations, Material Management Activities, and Key Environmental Reviews .....	1.12
1.4	Radioactive Material Disposition at Hanford in Terms of Waste Activity (MCi).....	1.13
1.5	Treatment Action Alternatives.....	1.41
1.6	Disposal Action Alternatives .....	1.42
1.7	Development of Alternative Groups.....	1.44
2.1	Waste Types and Waste Streams Considered in the HSW EIS .....	2.2
2.2	Long-Length Tank Equipment.....	2.6
2.3	Aerial View of the Central Waste Complex .....	2.13
2.4	Storage of Waste Drums in Central Waste Complex.....	2.14
2.5	Schematic Drawing of RH TRU Caisson in the LLBGs .....	2.15
2.6	Waste Receiving and Processing Facility .....	2.17
2.7	X-Ray Image of Transuranic Waste Drum Contents .....	2.17
2.8	Layout for the Waste Receiving and Processing Facility .....	2.18
2.9.	Transuranic Package Transporter-II Being Loaded in the Waste Receiving and Processing Facility .....	2.19
2.10	Macroencapsulation of Mixed Low-Level Waste Debris at a Commercial Treatment Facility.....	2.20
2.11	View of the T Plant Complex with 2706-T Facility and the T Plant Canyon Noted.....	2.22
2.12	Aerial View of a Low Level Burial Ground .....	2.24
2.13	High-Integrity Containers in a Low-Level Waste Disposal Trench .....	2.25
2.14	Trench Grouted Wastes.....	2.26
2.15	Treatment by Macroencapsulation at the LLBGs .....	2.27
2.16	Mixed Low-Level Waste Disposal Trench .....	2.29
2.17	Environmental Restoration Disposal Facility (ERDF) .....	2.32
2.18	Typical Liner System.....	2.34
2.19.	Modified RCRA Subtitle C Barrier for Mixed Low-Level Waste Trenches and the Low Level Burial Grounds .....	2.36
3.1	Options for HSW EIS Alternatives.....	3.2
3.2	Locations of Existing and Potential Processing and Disposal Facilities on the Hanford Site .....	3.4
3.3	Range of Waste Volumes Considered in the HSW EIS.....	3.5
3.4	Hypothetical Annual Dose from Drinking Water Containing Maximum Concentrations of Radionuclides in Groundwater at 1 km Downgradient from the 200 West Area Disposal Facilities as a Function of Calendar Year – Hanford Only and Upper Bound Waste Volumes .....	3.31
3.5	Hypothetical Annual Dose from Drinking Water Containing Maximum Concentrations of Radionuclides in Groundwater at 1 km Downgradient from ERDF as a Function of Calendar Year – Hanford Only and Upper Bound Waste Volumes .....	3.32

3.6	Hypothetical Annual Dose from Drinking Water Containing Maximum Concentrations of Radionuclides in Groundwater at 1 km Northwest Downgradient from the 200 East Area as Disposal Facilities as Function of Calendar Year – Hanford Only and Upper Bound Waste Volumes .....	3.33
3.7	Hypothetical Annual Dose from Drinking Water Containing Maximum Concentrations of Radionuclides in Groundwater at 1 km Downgradient Southeast from the 200 East Area Disposal Facilities as a Function of Calendar Year – Hanford Only and Upper Bound Waste Volumes .....	3.34
3.8	Hypothetical Annual Dose from Drinking Water Containing Maximum Concentrations of Radionuclides in Groundwater Near the Columbia River as a Function of Calendar Year – Hanford Only and Upper Bound Waste Volumes.....	3.35
3.9	Annual Dose to a Hypothetical Resident Gardener at Various Times over 10,000 Years Using Water from a Well 1 km Downgradient from 200 West Area .....	3.44
3.10	Annual Dose to a Hypothetical Resident Gardener at Various Times over 10,000 Years Using Water from a Well 1 km Downgradient from ERDF .....	3.45
3.11	Annual Dose to a Hypothetical Resident Gardener at Various Times over 10,000 Years Using Water from a Well 1 km Downgradient Northwest from 200 East Area .....	3.46
3.12	Annual Dose to a Hypothetical Resident Gardener at Various Times over 10,000 Years Using Water from a Well 1 km Downgradient Southeast of 200 East Area.....	3.47
3.13	Annual Dose to a Hypothetical Resident Gardener at Various Times over 10,000 Years Using Water from a Well Adjacent to the Columbia River .....	3.48
3.14	Annual Dose to a Hypothetical Resident Gardener with Sauna/Sweat Lodge at Various Times over 10,000 Years Using Water from a Well 1 km Downgradient from 200 West Area .....	3.49
3.15	Annual Dose to a Hypothetical Resident Gardener with Sauna/Sweat Lodge at Various Times over 10,000 Years Using Water from a Well 1 km Downgradient from ERDF.....	3.50
3.16	Annual Dose to a Hypothetical Resident Gardener with Sauna/Sweat Lodge at Various Times over 10,000 Years Using Water from a Well 1 km Downgradient Northwest from 200 East Area .....	3.51
3.17	Annual Dose to a Hypothetical Resident Gardener with Sauna/Sweat Lodge at Various Times over 10,000 Years Using Water from a Well 1 km Downgradient Southeast from 200 East Area.....	3.52
3.18	Annual Dose to a Hypothetical Resident Gardener with Sauna/Sweat Lodge at Various Times over 10,000 Years Using Water from a Well Adjacent to the Columbia River.....	3.53
4.1	Department of Energy – Hanford Site .....	4.2
4.2	DOE Preferred Alternative for Land Use on the Hanford Site from the Final Hanford Comprehensive Land-Use Plan EIS Record of Decision .....	4.4
4.3	Hanford Reach National Monument .....	4.8
4.4	200 West Area .....	4.9
4.5	200 East Area.....	4.10
4.6	Hanford Meteorological Monitoring Network.....	4.13
4.7	Wind Roses at the 9.1-m (30-ft) Level of the Hanford Meteorological Monitoring Network, 1982 to 2001 .....	4.15

4.8	Wind Roses at the 60-m (197-ft) Level of the Hanford Meteorological Monitoring Network, 1986 to 2001 .....	4.17
4.9	Geographic Setting and General Structural Geology of the Pasco Basin and Hanford Site.....	4.27
4.10	Stratigraphic Column for the Hanford Site .....	4.28
4.11	Generalized West to East Cross-Section of the Hanford Site Structure and Topography .....	4.29
4.12	Soil Map of the Hanford Site.....	4.31
4.13	Historical Seismicity of the Columbia Plateau and Surrounding Areas. ....	4.34
4.14	Seismicity of the Columbia Plateau and Surrounding Areas as Measured by Seismographs.....	4.35
4.15	Surface Water Features Including Rivers, Ponds, Major Springs, Ephemeral Streams, and Artificial Ponds on the Hanford Site .....	4.37
4.16	Extent of Probable Maximum Flood in Cold Creek Area.....	4.41
4.17	Groundwater Elevations for the Unconfined Aquifer at Hanford, March 2001 .....	4.46
4.18	Groundwater Elevations for the Unconfined Aquifer at the 200 Areas .....	4.47
4.19	Distribution of Major Radionuclides in Groundwater at Concentrations Above the Drinking Water Standards During FY 2001. ....	4.49
4.20	Distribution of Major Hazardous Chemicals in Groundwater at Concentrations Above the Drinking Water Standards During FY 2001.. ....	4.50
4.21	Distribution of Vegetation Types and Land Use Areas on the Hanford Site Prior to the <i>24 Command Fire</i> of 2000. ....	4.57
4.22	Distribution of Vegetation Types and Land Use Areas in the 200 West Area Prior to the <i>24 Command Fire</i> .....	4.64
4.23	Distribution of Vegetation Types and Land Use Areas in the 200 East Area Prior to the <i>24 Command Fire</i> .....	4.65
4.24	Species of Concern on the Hanford Site and the <i>24 Command Fire</i> Area.....	4.73
4.25	Location of Asian, Black, Hispanic, Native American, Pacific Islander, and Overall Minority Populations Near the Hanford Site .....	4.85
4.26	Location of Low-Income Populations Near the Hanford Site .....	4.88
4.27	Transportation Routes in the Vicinity of the Hanford Site .....	4.91
4.28	Transportation Routes on the Hanford Site.....	4.93
4.29	Occupational Injury and Illness Total Recordable Case Rates at the Hanford Site Compared with the DOE Complex and Private Industry .....	4.99
4.30	Average Occupational Dose (mrem/yr) to Hanford Site Individuals with Measurable Dose, 1997-2001. ....	4.101
4.31	Collective Operational Dose (person-rem/yr) at the Hanford Site, 1997-2001 .....	4.102
5.1	Schematic Representation of Computational Framework and Codes Used in the HSW EIS.....	5.32
5.2	LOAs Used in Comparing Potential Long-Term Groundwater Quality Impacts .....	5.34
5.3	Technetium-99 Concentration Profiles at Various Lines of Analysis (Alternative Group A – Hanford Only and Upper Bound Waste Volumes).....	5.43
5.4	Iodine-129 Concentration Profiles at Various Lines of Analysis (Alternative Group A – Hanford Only and Upper Bound Waste Volumes).....	5.44

5.5	Technetium-99 Concentration Profiles at Various Lines of Analysis (Alternative Group B – Hanford Only and Upper Bound Waste Volumes) .....	5.45
5.6	Iodine-129 Concentration Profiles at Various Lines of Analysis (Alternative Group B – Hanford Only and Upper Bound Waste Volumes) .....	5.46
5.7	Technetium-99 Concentration Profiles at Various Lines of Analysis (Alternative Group C – Hanford Only and Upper Bound Waste Volumes) .....	5.47
5.8	Iodine-129 Concentration Profiles at Various Lines of Analysis (Alternative Group C – Hanford Only and Upper Bound Waste Volumes) .....	5.48
5.9	Technetium-99 Concentration Profiles at Various Lines of Analysis (Alternative Group D <sub>1</sub> – Hanford Only and Upper Bound Waste Volumes).....	5.49
5.10	Iodine-129 Concentration Profiles at Various Lines of Analysis (Alternative Group D <sub>1</sub> – Hanford Only and Upper Bound Waste Volumes).....	5.50
5.11	Technetium-99 Concentration Profiles at Various Lines of Analysis (Alternative Group D <sub>2</sub> – Hanford Only and Upper Bound Waste Volumes).....	5.51
5.12	Iodine-129 Concentration Profiles at Various Lines of Analysis (Alternative Group D <sub>2</sub> – Hanford Only and Upper Bound Waste Volumes).....	5.52
5.13	Technetium-99 Concentration Profiles at Various Lines of Analysis (Alternative Group D <sub>3</sub> – Hanford Only and Upper Bound Waste Volumes).....	5.53
5.14	Iodine-129 Concentration Profiles at Various Lines of Analysis (Alternative Group D <sub>3</sub> – Hanford Only and Upper Bound Waste Volumes).....	5.54
5.15	Technetium-99 Concentration Profiles at Various Lines of Analysis (Alternative Group E <sub>1</sub> – Hanford Only and Upper Bound Waste Volumes) .....	5.55
5.16	Iodine-129 Concentration Profiles at Various Lines of Analysis (Alternative Group E <sub>1</sub> – Hanford Only and Upper Bound Waste Volumes) .....	5.56
5.17	Technetium-99 Concentration Profiles at Various Lines of Analysis (Alternative Group E <sub>2</sub> – Hanford Only and Upper Bound Waste Volumes) .....	5.57
5.18	Iodine-129 Concentration Profiles at Various Lines of Analysis (Alternative Group E <sub>2</sub> – Hanford Only and Upper Bound Waste Volumes) .....	5.58
5.19	Technetium-99 Concentration Profiles at Various Lines of Analysis (Alternative Group E <sub>3</sub> – Hanford Only and Upper Bound Waste Volumes) .....	5.59
5.20	Iodine-129 Concentration Profiles at Various Lines of Analysis (Alternative Group E <sub>3</sub> – Hanford Only and Upper Bound Waste Volumes) .....	5.60
5.21	Technetium-99, and Iodine-129 Concentration Profiles at Various Lines of Analysis (No Action Alternative – Hanford Only Waste Volume) .....	5.61
5.22	Comparison of Predicted Peak Concentrations of Technetium-99 and Iodine-129 at 200 East SE LOA from Upper Bound Inventories in UngROUTED MLLW Disposed of After 2007 .....	5.76
5.23	Comparison of Predicted Peak Concentrations of Uranium-238 at 200 East SE LOA from Upper Bound Inventories in UngROUTED and Grouted MLLW Disposed of After 2007 .....	5.77
5.24	Impact of HSW EIS Alternatives on Total Hanford Employment .....	5.116
5.25	Impact of HSW EIS Alternatives on Solid Waste Program Employment .....	5.116
5.26	Impact of HSW EIS Alternatives Groups on Solid Waste Program Total Cost .....	5.117
5.27	Shipment-Mileages for Onsite and Offsite Waste Shipments.....	5.132



5.28	Highway Routes used in the Analysis of Offsite Transportation Impacts .....	5.136
5.29	Potential Transportation Impacts of Onsite and Offsite Waste Shipments—LCFs from Radiological Incident-Free Transport, Radiological Accidents, and Non-Radiological Emissions .....	5.139
5.30	Shipment Mileages and Potential Transportation Impacts of Onsite and Offsite Waste Shipments—Non-Radiological Accident Fatalities .....	5.140
5.31	Shipping Routes in Washington and Oregon.....	5.141
5.32	Association of Noise Levels with Common Sources or Activities.....	5.147
5.33	Location of the Resident Gardener for Routine Airborne Releases.....	5.156
5.34	Annual Dose to a Maximally Exposed Individual at Various Times over 10,000 Years Using Water from Various Locations – Alternative Group A, Hanford Only and Upper Bound Waste Volumes .....	5.219
5.35	Annual Dose to a Maximally Exposed Individual at Various Times over 10,000 Years Using Water from Various Locations – Alternative Group B, Hanford Only and Upper Bound Waste Volumes .....	5.224
5.36	Annual Dose to a Maximally Exposed Individual at Various Times over 10,000 Years Using Water from Various Locations – Alternative Group C, Hanford Only and Upper Bound Waste Volumes .....	5.228
5.37	Annual Dose to a Maximally Exposed Individual at Various Times over 10,000 Years Using Water from Various Locations – Alternative Group D <sub>1</sub> , Hanford Only and Upper Bound Waste Volumes .....	5.234
5.38	Annual Dose to a Maximally Exposed Individual at Various Times over 10,000 Years Using Water from Various Locations – Alternative Group D <sub>2</sub> , Hanford Only and Upper Bound Waste Volumes .....	5.239
5.39	Annual Dose to a Maximally Exposed Individual at Various Times over 10,000 Years Using Water from Various Locations – Alternative Group D <sub>3</sub> , Hanford Only and Upper Bound Waste Volumes .....	5.243
5.40	Annual Dose to a Maximally Exposed Individual at Various Times over 10,000 Years Using Water from Various Locations – Alternative Group E <sub>1</sub> , Hanford Only and Lower Bound Waste Volumes .....	5.248
5.41	Annual Dose to a Maximally Exposed Individual at Various Times over 10,000 Years Using Water from Various Locations – Alternative Group E <sub>2</sub> , Hanford Only and Upper Bound Waste Volumes .....	5.253
5.42	Annual Dose to a Maximally Exposed Individual at Various Times over 10,000 Years Using Water from Various Locations – Alternative Group E <sub>3</sub> , Hanford Only and Upper Bound Waste Volumes .....	5.258
5.43	Annual Dose to a Maximally Exposed Individual at Various Times over 10,000 Years Using Water from Various Locations – No Action Alternative, Hanford Only and Upper Bound Waste Volumes .....	5.263
5.44	Concentrations of Technetium-99, Iodine-129, and Uranium in Groundwater Southeast of the 200 East Area from All Hanford Sources.....	5.290
5.45	Hypothetical Drinking Water Dose from Technetium-99, Iodine-129, and Uranium in Groundwater Southeast of the 200 East Area from All Hanford Sources .....	5.290

5.46	Hypothetical Total Drinking Water Dose from Groundwater for All Hanford Sources and the Hanford Solid Waste Contribution at the Line of Analysis Southeast of the 200 East Area.....	5.292
5.47	Concentrations of Technetium-99, Iodine-129, and Uranium in the Columbia River at the City of Richland Pumping Station from All Hanford Sources .....	5.292
5.48	Drinking Water Dose from Technetium-99, Iodine-129, and Uranium in the Columbia River at the City of Richland Pumping Station from All Hanford Sources.....	5.294
5.49	Hypothetical Total Drinking Water Dose from All Hanford Sources and the Hanford Solid Waste Contribution in the Columbia River at the City of Richland Pumping Station.....	5.294

# Tables

1.1	Consequences of Retrieving and Processing TRU Waste as Evaluated in the HDW EIS .....	1.19
3.1	Treatment Alternatives Summary .....	3.13
3.2	Disposal Alternatives Summary .....	3.14
3.3	Estimated Volumes of LLW Waste Streams .....	3.19
3.4	Estimated Volumes of MLLW Waste Streams.....	3.20
3.5	Estimated Volumes of TRU Waste Streams.....	3.20
3.6	Estimated Volumes of WTP Waste Streams Through 2046.....	3.21
3.7	Summary Comparison of Potential Impacts Among the Alternatives During Operational Period (Present to 2046).....	3.22
3.8	Summary Comparison of Hypothetical Long-Term (up to 10,000 years) Impacts Among the Alternatives .....	3.24
3.9	Comparison of Land Area Permanently Committed in the Various Alternatives as of 2046, ha.....	3.25
3.10	Comparison Among the Alternative Groups of Estimated Criteria-Pollutant Impact Maximums for Solid Waste Operations in the 200 Areas, Percent of Air Quality Standards.....	3.26
3.11	Highest Percentage of Maximum Contaminant Levels to the Year 12,050 A.D. ....	3.28
3.12	Highest Percentage of Maximum Contaminant Levels from 10,200 to 12,050 A.D. – All Due to Uranium .....	3.29
3.13	Comparison of Commitments of Geologic Resources, Millions of m <sup>3</sup> .....	3.36
3.14	Summary Comparison of Potential Radiological and Non-Radiological Transportation Impacts – Hanford Only Waste Volumes .....	3.38
3.15	Potential Impacts in Oregon and Washington by State from Shipments of Solid Wastes to and from Hanford .....	3.38
3.16	Comparison of Fossil Fuel Commitments Among the Alternatives .....	3.40
3.17	Comparison of Worker Health Impacts .....	3.40
3.18	Comparison of Public Health Impacts from Emissions of Radioactive Material to the Atmosphere During Routine Operations.....	3.41
3.19	Comparison of Consequences of Industrial Accidents on Workers Among the Alternatives .....	3.41
3.20	Comparison of Health Impacts on the Public from Routine Atmospheric Releases of Chemicals .....	3.42
3.21	(Sheet 1). Consolidated Cost Estimates for Alternative Groups A, B, and C.....	3.62
3.21	(Sheet 2). Consolidated Cost Estimates for Alternative Groups D, E, and No Action .....	3.63
4.1.	Station Numbers, Names, and Meteorological Parameters for Each Hanford Meteorological Monitoring Network Site.....	4.14
4.2	Number of Days with Peak Gusts Above Specific Thresholds at 15-m (50-ft) Level, 1945 through 2001 .....	4.18
4.3	Monthly and Annual Prevailing Wind Directions, Average Speeds, and Peak Gusts at 15-m (50-ft) Level, 1945 through 2001. ....	4.18

4.4	Estimate of the Probability of Extreme Winds Associated with Tornadoes Striking a Point at Hanford .....	4.19
4.5	Percent Probabilities for Extended Periods of Surface-Based Inversions .....	4.21
4.6	Federal and Washington State Ambient Air Quality Standards.....	4.22
4.7	Non-Radioactive Constituents Emitted to the Atmosphere for the Year 2001 .....	4.24
4.8	Radionuclides Emitted to the Atmosphere at the Hanford Site, 2001 .....	4.25
4.9	Soil Types on the Hanford Site .....	4.32
4.10	Maximum Concentrations of Groundwater Contaminants at Hanford in FY 2001 .....	4.51
4.11	Common Vascular Plants on the Hanford Site .....	4.59
4.12	Federally Listed Threatened, Endangered, Candidate Species, and Species of Concern and Washington State-Listed Threatened and Endangered Species Occurring or Potentially Occurring on the Hanford Site.....	4.69
4.13	Washington State Candidate Animal Species Found on the Hanford Site .....	4.70
4.14	Washington State Plant Species of Concern Occurring on the Hanford Site, as Determined by the Washington Natural Heritage Program 2002 .....	4.72
4.15	Birds of Conservation Concern Observed on the Hanford Site. ....	4.74
4.16	Population Estimates and Percentages by Race and Hispanic Origin within Selected County in Washington State and the 80-km (50 mi) Radius of Hanford as Determined by the 2000 Census .....	4.86
4.17	Number and Percentages of Persons Defined as Low-Income Living in Counties Near the Hanford Site, in 1999, as Determined by the 2000 Census.....	4.87
4.18	Occupational Injury, Illness, and Fatality Incidence Rates for U.S. Department of Energy Facilities and Private Industry .....	4.100
4.19	Radiation Exposure Data for the Hanford Site, 1997-2001 .....	4.102
5.1	Land Use – Areas Used for Disposal, ha .....	5.11
5.2	Land Use – Areas of HSW Treatment and Storage Facilities, ha .....	5.15
5.3	200 East and 200 West Area Emissions: Location and Dispersion Factors Used to Determine Maximum Air Quality Impacts to the Public.....	5.18
5.4	Area C (Borrow Pit) Emissions: Location and Dispersion Factors Used to Determine Maximum Air Quality Impacts to the Public.....	5.19
5.5	Alternative Group A: Maximum Air Quality Impacts to the Public from Activities in the 200 Areas.....	5.20
5.6	All Alternative Groups: Maximum Air Quality Impacts to the Public from Area C (Borrow Pit) Activities.....	5.20
5.7	Alternative Group B: Maximum Air Quality Impacts to the Public from Activities in the 200 Areas.....	5.22
5.8	Alternative Group C: Maximum Air Quality Impacts to the Public from Activities in the 200 Areas.....	5.23
5.9	Alternative Group D: Maximum Air Quality Impacts to the Public from Activities in the 200 Areas.....	5.24
5.10	Alternative Group E: Maximum Air Quality Impacts to the Public from Activities in the 200 Areas.....	5.26
5.11	No Action Alternative: Maximum Air Quality Impacts to the Public from Activities in the 200 Areas.....	5.27

5.12	Comparison Across all Alternative Groups of Maximum Air Quality Impacts to the Public from Activities in the 200 Areas.....	5.29
5.13	Comparison of Predicted Peak Concentrations of Selected Constituents at the 200 East SE LOA from Upper Bound Inventories in Ungroued MLLW Disposed of After 2007 .....	5.78
5.14	Sum of MCL Fractions and Drinking Water Doses from Maximum Potential Concentrations at LLWMA Boundaries for Technetium-99 and Iodine-129 for Waste Buried Before 2008.....	5.84
5.15	Sum of MCL Fractions and Drinking Water Doses from Maximum Potential Concentrations at Combined-Use Facility Boundaries for Technetium-99 and Iodine-129 for Waste Buried After 2007 .....	5.86
5.16	Estimated Inventories of Selected Hazardous Chemicals Potentially Disposed of in HSW LLBGs Between 1962 and 1987 .....	5.92
5.17	Estimated Peak Concentrations in Groundwater from Selected Hazardous Chemicals in Waste Hypothetically Disposed of in HSW LLBGs Before 1988 .....	5.95
5.18	Comparison of Commitments of Geologic Resources, Millions of m <sup>3</sup> .....	5.96
5.19	Hanford Budget and Direct Employment Associated with Baseline Conditions.....	5.115
5.20	Socioeconomic Impacts Associated with Alternative Group A, Relative to Baseline Conditions .....	5.118
5.21	Socioeconomic Impacts Associated with Alternative Group B, Relative to Baseline Conditions .....	5.120
5.22	Socioeconomic Impacts Associated with Alternative Group C, Relative to Baseline Conditions .....	5.122
5.23	Socioeconomic Impacts Associated with Alternative Group D, Relative to Baseline Conditions .....	5.123
5.24	Socioeconomic Impacts Associated with the No Action Alternative, Relative to Baseline Conditions .....	5.125
5.25	Summary of Potential Radiological and Non-Radiological Transportation Impacts – Hanford Only Waste Volumes, All Alternative Groups .....	5.133
5.26	Summary of Radiological and Non-Radiological Transportation Impacts for Offsite Shipments by Waste Type .....	5.135
5.27	Summary of the Potential Transportation Impacts by Shipment Origin.....	5.138
5.28	Impacts in Oregon and Washington by State from Shipments of Solid Wastes to and from Hanford .....	5.144
5.29	Impacts of Transporting Construction and Capping Materials .....	5.145
5.30	Hazardous Chemical Concentrations (mg/m <sup>3</sup> ) 100 m (109 yd) Downwind from Severe Transportation Accidents .....	5.146
5.31	Typical Noise Levels Associated with Construction Equipment and Blasting.....	5.149
5.32	Resource Commitment Summary by Alternative Group and for ILAW .....	5.152
5.33	Resource Commitment Summary by Alternative Group with ILAW Resources Included .....	5.153
5.34	Non-Involved Worker and Public Health Impacts from Routine Atmospheric Releases of Radionuclides – Alternative Group A, Hanford Only Waste Volume .....	5.160
5.35	Non-Involved Worker and Public Health Impacts from Routine Atmospheric Releases of Radionuclides – Alternative Group A, Lower Bound Waste Volume.....	5.161



5.36	Non-Involved Worker and Public Health Impacts from Routine Atmospheric Releases of Radionuclides – Alternative Group A, Upper Bound Waste Volume .....	5.162
5.37	Non-Involved Worker and Public Health Impacts from Routine Atmospheric Releases of Chemicals – Alternative Group A, All Waste Volumes .....	5.163
5.38	Occupational Radiation Exposure – Alternative Group A, Hanford Only Waste Volume.....	5.164
5.39	Occupational Radiation Exposure – Alternative Group A, Lower Bound Waste Volume.....	5.165
5.40	Occupational Radiation Exposure – Alternative Group A, Upper Bound Waste Volume .....	5.166
5.41	Radiological Consequences of Accidents at the CWC .....	5.168
5.42	Non-Radiological Air Concentrations for Accidents at the CWC .....	5.170
5.43	Radiological Consequences of Accidents at WRAP.....	5.171
5.44	Non-Radiological Air Concentrations for a Process Enclosure Fire Accident at WRAP.....	5.173
5.45	Radiological Consequences of Accidents at the Modified T Plant Complex for Continuing T Plant Activities .....	5.174
5.46	Radiological Consequences of Accidents for the Modified T Plant Complex with the New Waste Processing Facility .....	5.175
5.47	Radiological Consequences of Accidents at the Low-Level Waste Trenches .....	5.177
5.48	Radiological Consequences of Accidents at the MLLW Trenches .....	5.178
5.49	Non-Radiological Air Concentrations for a Heavy Equipment Accident with Fire at the LLBGs.....	5.179
5.50	Non-Radiological Air Concentrations for a Heavy Equipment Accident Without Fire at the LLBGs.....	5.180
5.51	Non-Radiological Air Concentrations for a Drum Explosion at the LLBGs.....	5.181
5.52	Non-Radiological Air Concentrations for a Seismic Event Without Fire at the LLBGs.....	5.182
5.53	Radiological Consequences of Accidents Involving ILAW Disposal .....	5.183
5.54	Non-Involved Worker and Public Health Impacts from Routine Atmospheric Releases of Radionuclides – Alternative Group B, Hanford Only Waste Volume .....	5.186
5.55	Non-Involved Worker and Public Health Impacts from Routine Atmospheric Releases of Radionuclides – Alternative Group B, Lower Bound Waste Volume.....	5.187
5.56	Non-Involved Worker and Public Health Impacts from Routine Atmospheric Releases of Radionuclides – Alternative Group B, Upper Bound Waste Volume .....	5.188
5.57	Non-Involved Worker and Public Health Impacts from Routine Atmospheric Releases of Chemicals – Alternative Group B, All Waste Volumes .....	5.189
5.58	Occupational Radiation Exposure – Alternative Group B, Hanford Only Waste Volume.....	5.190
5.59	Occupational Radiation Exposure – Alternative Group B, Lower Bound Waste Volume .....	5.191
5.60	Occupational Radiation Exposure – Alternative Group B, Upper Bound Waste Volume .....	5.192
5.61	Non-Involved Worker and Public Health Impacts from Routine Atmospheric Releases of Radionuclides – Alternative Group C, Hanford Only Waste Volume .....	5.196
5.62	Non-Involved Worker and Public Health Impacts from Routine Atmospheric Releases of Radionuclides – Alternative Group C, Lower Bound Waste Volume.....	5.197
5.63	Non-Involved Worker and Public Health Impacts from Routine Atmospheric Releases of Radionuclides – Alternative Group C, Upper Bound Waste Volume .....	5.198
5.64	Occupational Radiation Exposure – Alternative Group C, Hanford Only Waste Volume.....	5.199
5.65	Occupational Radiation Exposure – Alternative Group C, Lower Bound Waste Volume .....	5.200
5.66	Occupational Radiation Exposure – Alternative Group C, Upper Bound Waste Volume .....	5.201

5.67	Non-Involved Worker and Public Health Impacts from Routine Atmospheric Releases of Radionuclides – Alternative Group D, Hanford Only Waste Volume .....	5.202
5.68	Non-Involved Worker and Public Health Impacts from Routine Atmospheric Releases of Radionuclides – Alternative Group D, Lower Bound Waste Volume.....	5.203
5.69	Non-Involved Worker and Public Health Impacts from Routine Atmospheric Releases of Radionuclides – Alternative Group D, Upper Bound Waste Volume .....	5.204
5.70	Occupational Radiation Exposure – Alternative Group D, Hanford Only Waste Volume.....	5.206
5.71	Occupational Radiation Exposure – Alternative Group D, Lower Bound Waste Volume.....	5.207
5.72	Occupational Radiation Exposure – Alternative Group D, Upper Bound Waste Volume .....	5.208
5.73	Non-Involved Worker and Public Health Impacts from Routine Atmospheric Releases of Radionuclides – No Action Alternative, Hanford Only Waste Volume.....	5.211
5.74	Non-Involved Worker and Public Health Impacts from Routine Atmospheric Releases of Radionuclides – No Action Alternative, Lower Bound Waste Volume .....	5.212
5.75	Non-Involved Worker and Public Health Impacts from Routine Atmospheric Releases of Chemicals – No Action Alternative.....	5.213
5.76	Occupational Radiation Exposure – No Action Alternative, Hanford Only Waste Volume ....	5.214
5.77	Radiological Consequences of Melter Storage Accidents at the CWC .....	5.215
5.78	Population Health Impacts from Drinking Water Downstream of Hanford over 10,000 Years – Alternative Group A, Hanford Only Waste Volume .....	5.220
5.79	Population Health Impacts from Drinking Water Downstream of Hanford over 10,000 Years – Alternative Group A, Lower Bound Waste Volume .....	5.220
5.80	Population Health Impacts from Drinking Water Downstream of Hanford over 10,000 Years – Alternative Group A, Upper Bound Waste Volume.....	5.220
5.81	Maximum Annual Drinking Water Dose for a Hypothetical Well 1 km Downgradient from the 200 West Area, Alternative Group A.....	5.221
5.82	Maximum Annual Drinking Water Dose for a Hypothetical Well 1 km Downgradient Northwest from the 200 East Area, Alternative Group A.....	5.221
5.83	Maximum Annual Drinking Water Dose for a Hypothetical Well 1 km Downgradient Southeast from the 200 East Area, Alternative Group A.....	5.222
5.84	Maximum Annual Drinking Water Dose for a Hypothetical Well Near the Columbia River, Alternative Group A.....	5.222
5.85	Population Health Impacts from Drinking Water Downstream of Hanford over 10,000 Years – Alternative Group B, Hanford Only Waste Volume .....	5.225
5.86	Population Health Impacts from Drinking Water Downstream of Hanford over 10,000 Years – Alternative Group B, Lower Bound Waste Volume.....	5.225
5.87	Population Health Impacts from Drinking Water Downstream of Hanford over 10,000 Years – Alternative Group B, Upper Bound Waste Volume .....	5.225
5.88	Maximum Annual Drinking Water Dose for a Hypothetical Well 1 km Downgradient from the 200 West Area, Alternative Group B .....	5.226
5.89	Maximum Annual Drinking Water Dose for a Hypothetical Well 1 km Downgradient Northwest from the 200 East Area, Alternative Group B .....	5.226
5.90	Maximum Annual Drinking Water Dose for a Hypothetical Well Near the Columbia River, Alternative Group B .....	5.226

5.91	Population Health Impacts from Drinking Water Downstream of Hanford over 10,000 Years – Alternative Group C, Hanford Only Waste Volume .....	5.229
5.92	Population Health Impacts from Drinking Water Downstream of Hanford over 10,000 Years – Alternative Group C, Lower Bound Waste Volume.....	5.229
5.93	Population Health Impacts from Drinking Water Downstream of Hanford over 10,000 Years – Alternative Group C, Upper Bound Waste Volume .....	5.229
5.94	Maximum Annual Drinking Water Dose for a Hypothetical Well 1 km Downgradient from the 200 West Area, Alternative Group C .....	5.230
5.95	Maximum Annual Drinking Water Dose for a Hypothetical Well 1 km Downgradient Northwest from the 200 East Area, Alternative Group C.....	5.230
5.96	Maximum Annual Drinking Water Dose for a Hypothetical Well 1 km Downgradient Southeast from the 200 East Area, Alternative Group C .....	5.230
5.97	Maximum Annual Drinking Water Dose for a Hypothetical Well Near the Columbia River, Alternative Group C .....	5.231
5.98	Hypothetical Drinking Water Dose from Groundwater 100 Meters Downgradient of LLW Management Areas.....	5.232
5.99	Population Health Impacts from Drinking Water Downstream of Hanford over 10,000 Years – Alternative Group D <sub>1</sub> , Hanford Only Waste Volume .....	5.235
5.100	Population Health Impacts from Drinking Water Downstream of Hanford over 10,000 Years – Alternative Group D <sub>1</sub> , Lower Bound Waste Volume .....	5.235
5.101	Population Health Impacts from Drinking Water Downstream of Hanford over 10,000 Years – Alternative Group D <sub>1</sub> , Upper Bound Waste Volume.....	5.235
5.102	Maximum Annual Drinking Water Dose for a Hypothetical Well 1 km Downgradient from the 200 West Area, Alternative Group D <sub>1</sub> .....	5.236
5.103	Maximum Annual Drinking Water Dose for a Hypothetical Well 1 km Downgradient Northwest from the 200 East Area, Alternative Group D <sub>1</sub> .....	5.236
5.104	Maximum Annual Drinking Water Dose for a Hypothetical Well 1 km Downgradient Southeast from the 200 East Area, Alternative Group D <sub>1</sub> .....	5.237
5.105	Maximum Annual Drinking Water Dose for a Hypothetical Well Near the Columbia River, Alternative Group D <sub>1</sub> .....	5.237
5.106	Population Health Impacts from Drinking Water Downstream of Hanford over 10,000 Years – Alternative Group D <sub>2</sub> , Hanford Only Waste Volume .....	5.240
5.107	Population Health Impacts from Drinking Water Downstream of Hanford over 10,000 Years – Alternative Group D <sub>2</sub> , Lower Bound Waste Volume .....	5.240
5.108	Population Health Impacts from Drinking Water Downstream of Hanford over 10,000 Years – Alternative Group D <sub>2</sub> , Upper Bound Waste Volume.....	5.240
5.109	Maximum Annual Drinking Water Dose for a Hypothetical Well 1 km Downgradient from the 200 West Area, Alternative Group D <sub>2</sub> .....	5.241
5.110	Maximum Annual Drinking Water Dose for a Hypothetical Well 1 km Downgradient Northwest from the 200 East Area, Alternative Group D <sub>2</sub> .....	5.241
5.111	Maximum Annual Drinking Water Dose for a Hypothetical Well Near the Columbia River, Alternative Group D <sub>2</sub> .....	5.242
5.112	Population Health Impacts from Drinking Water Downstream of Hanford over 10,000 Years – Alternative Group D <sub>3</sub> , Hanford Only Waste Volume .....	5.244

5.113	Population Health Impacts from Drinking Water Downstream of Hanford over 10,000 Years – Alternative Group D <sub>3</sub> , Lower Bound Waste Volume .....	5.244
5.114	Population Health Impacts from Drinking Water Downstream of Hanford over 10,000 Years – Alternative Group D <sub>3</sub> , Upper Bound Waste Volume.....	5.244
5.115	Maximum Annual Drinking Water Dose for a Hypothetical Well 1 km Downgradient from the 200 West Area, Alternative Group D <sub>3</sub> .....	5.245
5.116	Maximum Annual Drinking Water Dose for a Hypothetical Well 1 km Downgradient from the ERDF Site, Alternative Group D <sub>3</sub> .....	5.245
5.117	Maximum Annual Drinking Water Dose for a Hypothetical Well 1 km Downgradient Northwest from the 200 East Area, Alternative Group D <sub>3</sub> .....	5.246
5.118	Maximum Annual Drinking Water Dose for a Hypothetical Well Near the Columbia River, Alternative Group D <sub>3</sub> .....	5.246
5.119	Population Health Impacts from Drinking Water Downstream of Hanford over 10,000 Years – Alternative Group E <sub>1</sub> , Hanford Only Waste Volume .....	5.249
5.120	Population Health Impacts from Drinking Water Downstream of Hanford over 10,000 Years – Alternative Group E <sub>1</sub> , Lower Bound Waste Volume.....	5.249
5.121	Population Health Impacts from Drinking Water Downstream of Hanford over 10,000 Years – Alternative Group E <sub>1</sub> , Upper Bound Waste Volume .....	5.249
5.122	Maximum Annual Drinking Water Dose for a Hypothetical Well 1 km Downgradient from the 200 West Area, Alternative Group E <sub>1</sub> .....	5.250
5.123	Maximum Annual Drinking Water Dose for a Hypothetical Well 1 km Downgradient from the ERDF Site, Alternative Group E <sub>1</sub> .....	5.250
5.124	Maximum Annual Drinking Water Dose for a Hypothetical Well 1 km Downgradient Northwest from the 200 East Area, Alternative Group E <sub>1</sub> .....	5.251
5.125	Maximum Annual Drinking Water Dose for a Hypothetical Well Near the Columbia River, Alternative Group E <sub>1</sub> .....	5.251
5.126	Population Health Impacts from Drinking Water Downstream of Hanford over 10,000 Years – Alternative Group E <sub>2</sub> , Hanford Only Waste Volume .....	5.254
5.127	Population Health Impacts from Drinking Water Downstream of Hanford over 10,000 Years – Alternative Group E <sub>2</sub> , Lower Bound Waste Volume.....	5.254
5.128	Population Health Impacts from Drinking Water Downstream of Hanford over 10,000 Years – Alternative Group E <sub>2</sub> , Upper Bound Waste Volume .....	5.254
5.129	Maximum Annual Drinking Water Dose for a Hypothetical Well 1 km Downgradient from the 200 West Area, Alternative Group E <sub>2</sub> .....	5.255
5.130	Maximum Annual Drinking Water Dose for a Hypothetical Well 1 km Downgradient from the ERDF Site, Alternative Group E <sub>2</sub> .....	5.255
5.131	Maximum Annual Drinking Water Dose for a Hypothetical Well 1 km Downgradient Northwest from the 200 East Area, Alternative Group E <sub>2</sub> .....	5.256
5.132	Maximum Annual Drinking Water Dose for a Hypothetical Well 1 km Downgradient Southeast from the 200 East Area, Alternative Group E <sub>2</sub> .....	5.256
5.133	Maximum Annual Drinking Water Dose for a Hypothetical Well Near the Columbia River, Alternative Group E <sub>2</sub> .....	5.257
5.134	Population Health Impacts from Drinking Water Downstream of Hanford over 10,000 Years – Alternative Group E <sub>3</sub> , Hanford Only Waste Volume .....	5.259

5.135	Population Health Impacts from Drinking Water Downstream of Hanford over 10,000 Years – Alternative Group E <sub>3</sub> , Lower Bound Waste Volume.....	5.259
5.136	Population Health Impacts from Drinking Water Downstream of Hanford over 10,000 Years – Alternative Group E <sub>3</sub> , Upper Bound Waste Volume .....	5.259
5.137	Maximum Annual Drinking Water Dose for a Hypothetical Well 1 km Downgradient from the 200 West Area, Alternative Group E <sub>3</sub> .....	5.260
5.138	Maximum Annual Drinking Water Dose for a Hypothetical Well 1 km Downgradient from the ERDF Site, Alternative Group E <sub>3</sub> .....	5.260
5.139	Maximum Annual Drinking Water Dose for a Hypothetical Well 1 km Downgradient Northwest from the 200 East Area, Alternative Group E <sub>3</sub> .....	5.261
5.140	Maximum Annual Drinking Water Dose for a Hypothetical Well 1 km Downgradient Southeast from the 200 East Area, Alternative Group E <sub>3</sub> .....	5.261
5.141	Maximum Annual Drinking Water Dose for a Hypothetical Well Near the Columbia River, Alternative Group E <sub>3</sub> .....	5.262
5.142	Population Health Impacts from Drinking Water Downstream of Hanford over 10,000 Years – No Action Alternative, Hanford Only Waste Volume.....	5.264
5.143	Population Health Impacts from Drinking Water Downstream of Hanford over 10,000 Years – No Action Alternative, Lower Bound Waste Volume.....	5.264
5.144	Maximum Annual Drinking Water Dose for a Hypothetical Well 1 km Downgradient from the 200 West Area, No Action Alternative. ....	5.264
5.145	Maximum Annual Drinking Water Dose for a Hypothetical Well 1 km Downgradient Northwest from the 200 East Area, No Action Alternative .....	5.265
5.146	Maximum Annual Drinking Water Dose for a Hypothetical Well 1 km Downgradient Southeast from the 200 East Area, No Action Alternative .....	5.265
5.147	Maximum Annual Drinking Water Dose for a Hypothetical Well Near the Columbia River, No Action Alternative .....	5.266
5.148	Maximum Impacts to an Individual from Drilling into Low Level Burial Grounds .....	5.267
5.149	Maximum Impacts to an Individual from Excavation into Low Level Burial Grounds .....	5.268
5.150	Cumulative Air Quality Impacts for Criteria Pollutants .....	5.280
5.151	Largest Criteria-Pollutant Impacts for HSW Operations Among the Alternative Groups and the No Action Alternative .....	5.280
5.152	Cumulative Population Health Effects in the Hanford Environs from Atmospheric Pathways due to Hanford Site Activities .....	5.284
5.153	Radiological Impacts (principally from uranium) in Various Sources of Water on, Near, or Downstream of the Hanford Site .....	5.297
5.154	Cumulative Transportation Impacts.....	5.298
5.155	Irreversible and Irrecoverable Commitments of Selected Resources by Alternative Group with ILAW .....	5.301
6.1	Potential Permits and Approvals Needed for Storage and Disposal .....	6.22
6.2	Coverage of Hanford Solid Waste Management Units in Existing Permits .....	6.24



## Acronyms/Abbreviations

AADT	annual average daily traffic
AEA	Atomic Energy Act
AEC	U.S. Atomic Energy Commission
ALARA	as low as reasonably achievable
ALE	Fitzner/Eberhardt Arid Lands Ecology (Reserve)
ANSI	American National Standards Institute
APL	Accelerated Process Line
ARAR	applicable or relevant and appropriate requirement
ATG	Allied Technology Group, Inc.
BCAA	Benton Clean Air Authority
BCF	bioconcentration factor
BDAT	best demonstrated available technology
BHI	Bechtel Hanford, Inc.
BLS	Bureau of Labor Statistics
BNSF	Burlington Northern and Santa Fe Railway
BPA	(U.S. Department of Energy) Bonneville Power Administration
BRMiS	Hanford Site Biological Resources Mitigation Strategy
BRMaP	Hanford Site Biological Resources Management Plan
BWIP	Basalt Waste Isolation Project
C3T	cleanup, constraint, and challenges team
CAA	Clean Air Act
CAIRS	Computerized Accident/Incident Reporting System
Cat 1	Category 1 low-level waste (Hanford Site)
Cat 3	Category 3 low-level waste (Hanford Site)
CBC	Columbia Basin College
CCP	Comprehensive Conservation Plan
CDE	committed dose equivalent
CEDE	committed effective dose equivalent
CEQ	Council on Environmental Quality
CERCLA	Comprehensive Environmental Response, Compensation, and Liability Act
CFEST	Coupled Fluid, Energy, and Solute Transport (computer code)
CFR	Code of Federal Regulations
CH	contact-handled
Ci	curie(s)
CNSS	Council of the National Seismic System
CO	carbon monoxide
CRCIA	Columbia River Comprehensive Impact Assessment
CRD	Comment Response Document

CSB	Canister Storage Building
CWC	Central Waste Complex
D&D	decontamination and decommissioning
dB	decibel(s)
dBA	A-weighted decibel(s)
DCG	derived concentration guide
DEIS	Draft Environmental Impact Statement
D <sub>l</sub>	longitudinal dispersivity
DOE	U.S. Department of Energy
DOE-ORP	U.S. Department of Energy, Office of River Protection
DOE-RL	U.S. Department of Energy, Richland Operations Office
DOL	U.S. Department of Labor
DOT	U.S. Department of Transportation
D <sub>t</sub>	transverse dispersivity
DWS	drinking water standard
EA	environmental assessment
ECAMP	Ecological Compliance Assessment Management Plan
ECEM	Ecological Contaminant Exposure Model (computer code)
Ecology	Washington State Department of Ecology
EDE	effective dose equivalent
EDNA	environmental designation for noise abatement
EH	U.S. Department of Energy Office of Environment, Safety and Health
EHQ	environmental hazard quotient
EIS	environmental impact statement
EM	U.S. Department of Energy Office of Environmental Management
EMI	environmental management integration
EMSL	Environmental and Molecular Sciences Laboratory
ENCO	enterprise companies
EOC	Emergency Operations Center
EPA	U.S. Environmental Protection Agency
ERDA	U.S. Energy Research and Development Administration
ER	environmental restoration
ERDF	Environmental Restoration Disposal Facility
ERPG	Emergency Response Planning Guideline
ERTC	Effluent Retention and Treatment Complex
ESA	Endangered Species Act
ESU	Evolutionarily Significant Unit
ETF	200 Area Effluent Treatment Facility
FEMA	Federal Emergency Management Agency
FFS	focused feasibility study
FFTF	Fast Flux Test Facility

FH	Fluor Hanford, Inc.
FONSI	finding of no significant impact
FR	<i>Federal Register</i>
FRAMES	Framework for Risk Analysis in Multimedia Environmental Systems (computer code)
FTE	full-time equivalent (or full-time employee)
FWS	U.S. Fish and Wildlife Service
FY	fiscal year
GC	U.S. Department of Energy Office of General Counsel
GIS	geographic information system
GOCO	government-owned contractor-operated
GPS	global positioning system
GTC3	greater than Category 3 low-level waste (Hanford Site)
GTCC	greater than Class C low-level waste (NRC)
HAMMER	Hazardous Materials Management and Emergency Response Facility (Volpentest Training and Education Center)
HCP EIS	Hanford Comprehensive Land-Use Plan Environmental Impact Statement
HCRC	Hanford Cultural Resources Case
HCRL	Hanford Cultural Resources Laboratory
HDPE	high-density polyethylene
HDW EIS	Disposal of Hanford Defense High-Level, Transuranic, and Tank Wastes Environmental Impact Statement
HEHF	Hanford Environmental Health Foundation
HEPA	high-efficiency particulate air
HIC	high-integrity container
HLW	high-level (radioactive) waste
HMS	Hanford Meteorology Station
HPMP	Hanford Performance Management Plan
HPPE	high-density polyethylene
HSRAM	Hanford Site Risk Assessment Methodology
HSSWAC	Hanford Site solid waste acceptance criteria
HSW	Hanford solid waste within Hanford Solid Waste Program
HSW EIS	Hanford Site Solid (Radioactive and Hazardous) Waste Program Environmental Impact Statement
HTWOS	Hanford Tank Waste Operating System
HW	hazardous waste
HWMA	Washington State Hazardous Waste Management Act
HWMP	Hanford Waste Management Program
HWVP	Hanford Waste Vitrification Project
Hz	hertz

ICRP	International Commission on Radiological Protection
IDF	integrated disposal facility
IDLH	Immediately Dangerous to Life and Health
ILAW	immobilized low-activity waste
IPABS	Integrated Planning, Accountability and Budgeting System
ISCST3	Industrial Source Complex Short-Term Model, version 3 (computer code)
ISO	International Standards Organization
ISS	interim safe storage
$K_d$	distribution coefficient for partitioning of contaminants in soil
LCF	latent cancer fatality
LC50	chemical concentration reported to be lethal to 50 percent of the exposed organisms after some period of exposure, usually a few hours to a few days
LD50	dose reported to be lethal to 50 percent of the exposed organisms after some period of exposure, usually a few hours to a few days
LDR	Land Disposal Restriction
LEPC	Local Emergency Planning Committee
LERF	Liquid Effluent Retention Facility
LIGO	Laser Interferometer Gravitational-Wave Observatory
LLBG	Low Level Burial Ground
LLW	low-level (radioactive) waste
LLW MA	low-level waste management area
LMF	lined modular facility
LOA	line of analysis
LOEC	lowest observed effects concentration
LOEL	lowest observed effects level
LOS	level of service
LWC	lost workday case
LWD	lost workday
M&O	management and operations
MASS2	Modular Aquatic Simulation System 2 (computer code)
MBTA	Migratory Bird Treaty Act
MCL	maximum contaminant level
MEI	maximally exposed individual
MEK	methyl ethyl ketone
MEPAS	Multimedia Environmental Pollutant Assessment System
MLLW	mixed low-level waste
MMEDE	Multimedia-Modeling Environmental Database Editor (computer code)
MMI	Modified Mercalli Intensity
MT	metric ton(s) (tonnes)
MTCA	Model Toxics Control Act
MTG	minimum technology guidance
MTU	metric tons of uranium

NAAQS	National Ambient Air Quality Standards
National Register	National Register of Historic Places
NCRP	National Council on Radiation Protection and Measurements
NDA	non-destructive assay
NDE	non-destructive examination
ND	not detected
NE	no emissions
NEPA	National Environmental Policy Act
NESHAPs	National Emission Standards for Hazardous Air Pollutants
NIOSH	National Institute for Occupational Safety and Health
NM	not measured
NMFS	National Marine Fisheries Service
NO <sub>2</sub>	nitrogen dioxide
NOA	Notice of Availability
NOAEL	no observed adverse effects level
NOC	Notice of Construction
NOE	Notice of Extension
NOI	Notice of Intent
NPDES	National Pollutant Discharge Elimination System
NPS	National Park Service
NRC	U.S. Nuclear Regulatory Commission
NS	no standard
NTS	Nevada Test Site
NWPF	new waste processing facility
NWS	National Weather Service
OAR	Oregon Administrative Rule
OCF	offsite commercial facility
OFM	Office of Financial Management
ORP	(U.S. Department of Energy) Office of River Protection
ORR	(U.S. Department of Energy) Oak Ridge Reservation
OSHA	U.S. Occupational Safety and Health Administration
PA	performance assessment
PCB	polychlorinated biphenyl
pCi	picocurie(s)
PEIS	Programmatic Environmental Impact Statement
PEL	permissible exposure level
PFP	Plutonium Finishing Plant
PHMC	Project Hanford Management Contract
PM	particulate matter
PM <sub>10</sub>	particulate matter with aerodynamic diameters 10 µm or smaller
PNNL	Pacific Northwest National Laboratory
ppm	parts per million

PSD	prevention of significant deterioration
Pu	plutonium
PUREX	Plutonium-Uranium Extraction Facility
R	roentgen
R&D	research and development
RADTRAN	Radioactive Transportation Risk Analysis (computer code)
RCRA	Resource Conservation and Recovery Act
RCT	radiological control technician
RCW	Revised Code of Washington
REIS	Regional Economic Information System
R <sub>f</sub>	contaminant retardation factors
RfD	reference dose
RH	remote-handled
RIMS	Regional Input-Output Modeling System (computer code)
RL	(U.S. Department of Energy) Richland Operations Office
ROD	Record of Decision
RPP	River Protection Project
SA	safety analysis
SAC	System Assessment Capability (computer code)
SALDS	State-Approved Land Disposal Structure
SC	species of concern
SCAPA	Subcommittee on Consequence Assessment and Protective Actions
SEIS	Supplemental Environmental Impact Statement
SEPA	State (of Washington) Environmental Policy Act
SERC	State Emergency Response Commission
SI	Le Système International d'Unites (International System of Units [metric system])
SIP	state implementation plan
SLD	shallow land disposal
SNF	spent nuclear fuel
SO <sub>2</sub>	sulfur dioxide
SR	State Route
SRS	(U.S. Department of Energy) Savannah River Site
SST	single-shell tank
STOMP	Subsurface Transport Over Multiple Phases (computer code)
STP	site treatment plan
SWB	standard waste box
SWBG	solid waste burial ground
SWIFT	Solid Waste Integrated Forecast Technical (report)
SWITS	Solid Waste Information and Tracking System
SWOC	Solid Waste Operations Complex

T&E	threatened and endangered (biological species designation)
TCP	traditional cultural property
TD	temperature difference
TEDE	total effective dose equivalent
TEDF	200 Area Treated Effluent Disposal Facility
TEEL	Temporary Emergency Exposure Limit
TI	Transportation Index
TLV	threshold limit value
TNC	The Nature Conservancy (of Washington)
TPA	Tri-Party Agreement (Hanford Federal Facility Agreement and Consent Order)
TRAGIS	Transportation Routing Analysis Geographic Information System (computer code)
TRC	total recordable case
TRIGA	Test Reactor and Isotope Production General Atomics
TRU	transuranic
TRUPACT-II	Transuranic Package Transporter-II
TRUSAF	Transuranic Storage and Assay Facility
TSCA	Toxic Substances Control Act
TSD	treatment, storage, and/or disposal
TSP	total suspended particulates
TWRS	Tank Waste Remediation System
UPR	unplanned release
UO <sub>3</sub>	uranium trioxide
USC	United States Code
USGS	U.S. Geological Survey
UW	University of Washington
UWGP	University of Washington Geophysics Program
VADER	VADose zone Environmental Release (computer code)
VOC	volatile organic compound
WAC	Washington Administrative Code
WDFW	Washington State Department of Fish and Wildlife
WDOH	Washington State Department of Health
WESF	Waste Encapsulation and Storage Facility
WHC	Westinghouse Hanford Company
WIF	well intercept factor
WIPP	Waste Isolation Pilot Plant
WIPP SEIS2	Waste Isolation Pilot Plant Disposal Phase Final Supplemental Environmental Impact Statement
WM	waste management
WM PEIS	Waste Management Programmatic Environmental Impact Statement
WNHP	Washington Natural Heritage Program

WRAP  
WSU-TC  
WTP

Waste Receiving and Processing Facility  
Washington State University – Tri-Cities Branch Campus  
waste treatment plant



## Glossary of Terms

**anadromous** – Migrating up rivers from the sea to breed in fresh water.

**aromatic** – Of, related to, or containing the six-carbon ring typical of the benzene series and related organic groups also, “having an aroma”.

**bioconcentration factor (BCF)** – The ratio of the tissue concentration of an aquatic organism to the water concentration where uptake is limited to water alone, usually derived in an experimental setting.

**borrow pit** – The excavation site used to obtain geological resources (such as sand, gravel, basalt rocks, or fine sediments).

**caisson** – As used in the HSW EIS, these structures are reinforced cylindrical steel and concrete underground vaults 2.4 m (8 ft) in diameter and 3-m (10-ft) high designed to store remote-handled waste in the Low Level Burial Grounds.

**candidate species** – Plants and animals with a status of concern, but about which more information is needed before they can be proposed for listing as threatened species or endangered species. A state candidate species is one that is being reviewed for possible listing as a state endangered, threatened, or sensitive species as specified by the Washington State Department of Fish and Wildlife. See also endangered species, threatened species, and species of concern.

**cap** – A cap used to cover a radioactive burial ground with soil, rock, vegetation, or other materials as part of the facility closure process. The cap is designed to reduce migration of radioactive and hazardous materials in the waste by infiltration of water or by intrusion of humans, plants, or animals from the surface. In this EIS, the modified RCRA Subtitle C barrier was selected to use as a cap for LLW and MLLW disposal grounds. (Also called “cover cap” and “barrier” in this EIS.)

**capping** – As applied to radioactive and mixed-waste disposal facilities, the process of covering a burial ground with soil, rock, vegetation, or other materials as part of the facility closure process.

**carcinogen** – A substance that can cause cancer.

**cask** – A heavily shielded container used to store or ship radioactive materials.

**Category 1 low-level waste** – Low-level radioactive waste containing radionuclide concentrations within the maximum limits defined for this waste type in the HSSWAC. These limits are site-specific, and they define the lowest activity category of low-level radioactive waste. Category 1 wastes typically do not require special packaging or treatment for disposal by shallow land burial.

**Category 3 low-level waste** – Low-level radioactive waste containing radionuclide concentrations greater than those defined for Category 1 waste, but within the maximum limits defined for Category 3 waste in

the HSSWAC. These limits are site-specific, and are established using the performance assessment for a particular disposal facility. Category 3 wastes typically require special packaging or treatment for disposal by shallow land burial.

**characterization** – See waste characterization.

**chemical oxidation** – Oxidation of a material by adding chemicals such as peroxide, ozone, persulfates, or other oxidizing material. Commonly used for oxidation of organic constituents.

**chemical reduction** – Reduction of a material by adding chemicals such as sulfites, polyethylene glycol, hydrosulfide, or ferrous salts. Commonly used for the reduction of hexavalent chromium to the trivalent state. In all these cases, the reduced forms of the contaminant are much less mobile in the environment because of their low solubility and high adsorption to soils. Microbiological reduction of these waste constituents also has been found to occur naturally in sediment and aquifer environments and with addition of chemical food sources to enhance the microbe growth rates reductive biological remediation is becoming more economical.

**cleanup** – The term cleanup refers the full range of projects and activities being undertaken to address environmental and legacy waste issues associated with the Hanford Site.

**closure** – As applied to radioactive and hazardous waste disposal facilities, the process of site stabilization and placement of caps or other barriers to provide long-term confinement of the waste.

**contact-handled (CH) waste** – Generally, packaged waste whose external surface dose rate does not exceed 200 mrem/hr and does not create a high radiation area (>100 mrem/hr at 30 cm). See also remote-handled waste.

**crib** – An underground structure designed to receive liquid waste that can percolate into the soil directly and/or after traveling through a connected tile field.

**criteria pollutants** – Six pollutants (carbon monoxide, suspended particulates of specified sizes, sulfur dioxide, lead, nitrogen oxide, and ozone) known to be hazardous to human health or structures and for which the U.S. Environmental Protection Agency (EPA) sets National Ambient Air Quality Standards under the Clean Air Act (40 CFR 50).<sup>(a)</sup>

**cullet** – Small pieces of glass (similar in size to pea-gravel) formed when hot molten glass is quenched in a water bath.

**cumulative impacts (effects)** – Impact on the environment that results from the incremental impact of the action when added to other past, present, and reasonably foreseeable future actions regardless of what agency (federal or non-federal) or person undertakes such other actions. Cumulative impacts can result from individually minor but collectively significant actions taking place over a period of time.

---

(a) 40 CFR 50. “National Primary and Secondary Ambient Air Quality Standards.” Code of Federal Regulations. Online at: [http://www.access.gpo.gov/nara/cfr/waisidx\\_01/40cfr50\\_01.html](http://www.access.gpo.gov/nara/cfr/waisidx_01/40cfr50_01.html)

**dangerous waste** – Solid waste designated in WAC 173-303-070<sup>(a)</sup> through WAC 173-303-100 as dangerous or extremely hazardous waste, or mixed waste.

**deactivation** – As applied to waste treatment, the removal of the hazardous characteristics of a waste due to its ignitability, corrosivity, and or reactivity.

**decibel** – A standard unit of sound pressure. The decibel is a value equal to 10 times the logarithm of the ratio of a sound pressure squared to a standard reference sound-pressure level (20 micropascals) squared.

**decommissioning** – Officially remove from service or demolish a facility.

**decontamination** – Final actions taken to reduce the potential health and safety impacts of DOE-contaminated facilities, including activities to stabilize, reduce, or remove radioactive and hazardous materials. Includes the removal, reduction, or neutralization of radionuclides and/or hazardous materials from contaminated facilities, equipment, or soils by washing, heating, chemical or electrochemical action, mechanical cleaning, or other techniques.

**deterministic analysis** – A single calculation using only a single value for each of the model parameters. A deterministic system is governed by definite rules of system behavior leading to cause and effect relationships and predictability. Deterministic calculations do not account for uncertainty in the physical relationships or parameter values. Typically, deterministic calculations are based on best estimates of the involved parameters. See stochastic analysis.

**disposal** – As generally used in this document, placement of waste with no intent to retrieve. Statutory or regulatory definitions of disposal may differ.

**dose** – The accumulated radiation or hazardous substance delivered to the whole body, or a specified tissue or organ, within a specified time interval, originating from an external or internal source. See also terms related to radiation exposure and dose.

**edaphic** – Of, or relating to, the soil.

**effluent** – Airborne and liquid wastes discharged to the environment.

**element occurrence** – An element occurrence of a plant community is one that meets the minimum standards set by the State of Washington Natural Heritage Program (WNHP) for ecological condition, size, and the surrounding landscape. Element occurrences are generally considered to be of significant conservation value from a state and/or regional perspective.

**endangered species (Federal)** – Plants or animals that are in danger of extinction throughout all or a significant portion of their ranges and have been listed as endangered by the U.S. Fish and Wildlife

---

(a) WAC 173-303. “Dangerous Waste Regulations.” Washington Administrative Code, Olympia, Washington. Online at: <http://www.leg.wa.gov/wac/index.cfm?fuseaction=chapterdigest&chapter=173-303>

Service or the National Marine Fisheries Service, following the procedures set out in the Endangered Species Act and its implementing regulations (50 CFR 424).<sup>(a)</sup>

**endangered species (State)** – Washington State defines endangered species as any wildlife species native to the state of Washington that is seriously threatened with extinction throughout all or a significant portion of its range within the state (WAC 232-12-297).<sup>(b)</sup> See also candidate species and threatened species.

**eolian** – Pertaining to, caused by, or carried by the wind.

**ERPG-1** – The maximum concentration in air below which it is believed nearly all individuals could be exposed for up to one hour without experiencing other than mild transient adverse health effects or perceiving a clearly defined objectionable odor.

**ERPG-2** – The maximum concentration in air below which it is believed nearly all individuals could be exposed for up to one hour without experiencing or developing irreversible or other serious health effects or symptoms that could impair their abilities to take protective action.

**ERPG-3** – The maximum concentration in air below which it is believed nearly all individuals could be exposed for up to one hour without experiencing or developing life-threatening health effects.

**Evolutionarily Significant Unit (ESU)** – A distinctive group of Pacific salmon, steelhead, or sea-run cutthroat trout.

**Federal species of concern** – Species whose conservation standing is of concern to the U.S. Fish and Wildlife Service but for which status information still is needed.

**fluvial** – Produced by the action of flowing water.

**french drain** – A rock-filled encasement with an open bottom to allow seepage of liquid waste into the ground.

**generator** – Within the context of this document, generators refer to organizations within DOE or managed by DOE whose act or process produces low-level waste, mixed low-level waste, or transuranic waste.

**graded approach** – A process by which the level of analysis, documentation, and actions necessary to comply with a requirement are commensurate with 1) the relative importance to safety, safeguards, and

---

(a) 50 CFR 424. “Listing Endangered and Threatened Species and Designating Critical Habitat.” Code of Federal Regulations. Online at: [http://www.access.gpo.gov/nara/cfr/waisidx\\_01/50cfr424\\_01.html](http://www.access.gpo.gov/nara/cfr/waisidx_01/50cfr424_01.html)

(b) WAC 232-12-297. “Endangered, threatened, and sensitive wildlife species classification.” Washington Administrative Code, Olympia, Washington. Online at: <http://www.leg.wa.gov/wac/index.cfm?fuseaction=Section&Section=232-12-297>

security; 2) the magnitude of any hazard involved; 3) the life cycle stage of a facility; 4) the programmatic mission of a facility; 5) the particular characteristics of a facility; and 6) any other relevant factor.

**greater than Category 3 (GTC3) low-level waste** – Low-level radioactive waste that exceeds the maximum radionuclide concentrations as defined for Category 3 low-level waste. See also Category 3 waste.

**Hanford Federal Facility Agreement And Consent Order** – See Tri-Party Agreement.

**hazardous waste** – Waste that contains chemically hazardous constituents regulated under Subtitle C of the Resource Conservation and Recovery Act (RCRA), as amended (40 CFR 261)<sup>(a)</sup> and regulated as a hazardous waste and/or mixed waste by the EPA. May also include solid waste designated by Washington State in WAC 173-303-070<sup>(b)</sup> through WAC 173-303-100 as dangerous or extremely hazardous waste, or mixed waste. See also mixed low-level waste.

**high-integrity container (HIC)** – A container that provides additional confinement for remote-handled Category 3 LLW and some contact-handled Category 3 LLW and is typically constructed of concrete or other durable material.

**high-level (radioactive) waste (HLW)** – High-level waste is the highly radioactive waste material resulting from the processing of spent nuclear fuel, including liquid waste produced directly in processing and any solid material derived from such liquid waste that contains fission products in sufficient concentrations, and other highly radioactive material that is determined, consistent with existing law, to require isolation.

**immobilization** – Placing the waste within a material such as concrete or a glass to immobilize (reduce dispersability and leachability of) the radioactive or hazardous components within the waste. See also stabilization.

**immobilized low-activity waste (ILAW)** – The solidified low-activity waste from the treatment and immobilization of Hanford tank wastes. See also low-activity waste.

**in-trench grouting** – In-trench grouting involves placing the waste on a cement pad or on spacers, installing reinforcement steel and forms around the waste, and covering the waste with fresh concrete to encapsulate the waste within a concrete barrier.

**lacustrine** – Of or pertaining to lakes.

---

(a) 40 CFR 261. “Identification and Listing of Hazardous Waste.” Code of Federal Regulations. Online at: [http://www.access.gpo.gov/nara/cfr/waisidx\\_01/40cfr261\\_01.html](http://www.access.gpo.gov/nara/cfr/waisidx_01/40cfr261_01.html)

(b) WAC 173-303. “Dangerous Waste Regulations.” Washington Administrative Code, Olympia, Washington. Online at: <http://www.leg.wa.gov/wac/index.cfm?fuseaction=chapterdigest&chapter=173-303>

**land disposal restrictions** – The restrictions and requirements for land disposal of hazardous or dangerous waste as specified in 40 CFR 268 (RCRA) and WAC 173-303-140 (Washington State Dangerous Waste Regulations).

**land-use designations:**

**Industrial-Exclusive** – An area suitable and desirable for treatment, storage, and disposal of hazardous, dangerous, radioactive, non-radioactive wastes, and related activities.

**Conservation (Mining)** – An area reserved for the management and protection of archeological, cultural, ecological, and natural resources. Limited and managed mining (for example, quarrying for sand, gravel, basalt, and topsoil for governmental purposes only) could occur as a special use (i.e., a permit would be required) within appropriate areas. Limited public access would be consistent with resource conservation. This designation includes related activities.

**latent cancer fatality (LCF)** – A cancer death postulated to result from, and occurring some time after, exposure to ionizing radiation or other carcinogens.

**As applied to populations**, the postulated number of fatal cancers in a given population due to the calculated or measured collective dose to that population as a result of a given action or activity.

**As applied to individuals**, the probability of a fatal cancer in a given individual due to the calculated or measured dose received by that individual as a result of a given action or activity.

**leachate** – As applied to mixed low-level waste trenches, any liquid, including any suspended components in the liquid, that has percolated through or drained from hazardous waste.

**lost workday cases (LWCs)** – Represent the number of cases recorded resulting in days away from work or days of restricted work activity, or both, for affected employees.

**lost workdays (LWDs)** – The total number of workdays (consecutive or not), after the day of injury or onset of illness, during which employees were away from work or limited to restricted work activity because of an occupational injury or illness.

**low-activity waste** – The waste that remains after separating from high-level waste as much of the radioactivity as practicable, and that when solidified may be disposed of as low-level waste in a near-surface facility.

**low-income person** – A person living in a household that reports an annual income less than the United States official poverty level, as reported by the U.S. Census Bureau.

**low-level (radioactive) waste (LLW)** – Radioactive waste that is not high-level waste, spent nuclear fuel, transuranic waste, byproduct material (as defined in section 11e[2] of the Atomic Energy Act of 1954, as amended), or naturally occurring radioactive material.

**macroencapsulation** – Treatment method applicable to debris wastes as defined by RCRA. Refers to application of surface coating materials, such as polymeric organics (for example, resins and plastics) or of a jacket of inert material to reduce surface exposure to potential leaching media.

**maximally exposed individual (MEI)** – The maximally exposed individual is a hypothetical person who has a lifestyle, and is in a location, such that that any other individual would be unlikely to receive a higher exposure to radiation or hazardous materials. The MEI may be an individual who resides or works near the Hanford Site, or who is temporarily at a publicly accessible location where the maximum dose from a short-term event would occur.

**microbiotic (cryptogamic) crusts** – generally occur in the top 1 to 4 mm of soil and are formed by living organisms and their by-products, creating a crust of soil particles bound together by organic materials.

**microencapsulation** – The encapsulation of waste components in the atomic structure of compounds or materials such as glass, cement, or polymer waste forms.

**minority** – Individual(s) who are members of the following population groups: American Indian or Alaskan Native; Asian or Pacific Islander; Black, not of Hispanic origin; or Hispanic.

**mixed low-level waste (MLLW)** – Low-level waste determined to contain both source, special nuclear, or byproduct material subject to the Atomic Energy Act of 1954, as amended, and a hazardous component subject to the Resource Conservation and Recovery Act (RCRA), as amended, or Washington State Dangerous Waste Regulations. See also hazardous waste, dangerous waste.

**modular facility** – As used in this HSW EIS, a modular disposal facility would consist of a number of expandable segments or areas within an overall master facility. Each module would be designed to handle certain waste types or forms. For example remote handled wastes might be in a different area or “module” than standard packages of contact handled low-level waste or mixed low-level waste.

**neutralization** – Changing the pH of a solution to near 7 by adding an acidic or basic material.

**no action alternative** – In this EIS, the no action alternative consists of continuing ongoing activities, but does not include development of new capabilities to manage wastes that cannot currently be disposed of.

**noise** – Sound that is unwanted and perceived as unpleasant or a nuisance.

**non-standard (packaging)** – Non-standard waste packages refer to specially designed waste containers or packages used for large, or odd shaped low-level waste, mixed low-level waste or transuranic waste items or items with high dose rates or other unique conditions. See also standard (packaging).

**normal operations** – As used in this HSW EIS, normal operations refers to routine waste management activities, for example, waste treatment activities (including processing), packaging and repackaging, storage, and final disposal of waste, and is exclusive of accident conditions, save for minor process upsets.

**order of magnitude** – As used in this EIS, an order of magnitude is taken as a power (or factor) of 10.

**operational waste** – Solid wastes that are generated in support of cleanup activities, including such items as contaminated personnel protective clothing, disposable laboratory supplies, and failed tools and equipment.

**physical extraction** – Separation or removal of materials or components based on size or material characteristic.

**PM<sub>10</sub>** – Particulates with an aerodynamic diameter less than or equal to a nominal diameter of 10 micrometers.

**PM<sub>2.5</sub>** – Particulates with an aerodynamic diameter less than or equal to a nominal diameter of 2.5 micrometers.

**pore water** – The amount of water effectively trapped or retained by a volume of soil.

**processing** – As used in this HSW EIS, refers to any activity necessary to prepare waste for disposal. Processing waste may consist of repackaging, removal, or stabilization of non-conforming waste, or treatment of physically or chemically hazardous constituents in compliance with state or federal regulations.

**radioactive waste** – In general, waste that is managed for its radioactive content. Waste material that contains source, special nuclear, or by-product material is subject to regulation as radioactive waste under the Atomic Energy Act. Also, waste material that contains accelerator-produced radioactive material or a high concentration of naturally occurring radioactive material may be considered radioactive waste.

**release** – Any spilling, leaking, pumping, pouring, emitting, emptying, discharging, injecting, escaping, leaching, dumping, or disposing of a material into the environment. Statutory or regulatory definitions of release may differ.

**remedial action** – Activities conducted to reduce potential risks to people and/or harm to the environment from radioactive and/or hazardous substance contamination. See also cleanup.

**remote-handled (RH) waste** – Packaged radioactive waste for which the external dose rate exceeds that defined for contact-handled waste (generally 200 mrem/hr at the container surface). These wastes require handling using remotely controlled equipment, or placement in shielded containers, to reduce the human exposures during routine waste management activities. See also contact-handled waste.

**retrievably stored waste** – Waste stored in a manner that is intended to permit retrieval at a future time.

**review 1 species** – A plant taxon of potential concern that is in need of additional field work before a status can be assigned. See also species of concern.



**shrub-steppe** – Plant community consisting of short-statured, widely spaced, small-leaved shrubs, sometimes aromatic, with brittle stems and an understory dominated by perennial bunchgrasses.

**sensitive species** – A taxon that is vulnerable or declining and could become endangered or threatened in Washington state without active management or removal of threats. The federal listings classify species as listed (endangered/threatened), candidate, or proposed.

**seep** – To flow slowly, or ooze; on the Columbia River, seepage occurs below the river surface and exposed riverbank, particularly noticeable at low-river stage. The seeps flow intermittently, apparently influenced primarily by changes in the river level.

**site** – A geographic entity comprising leased or owned land, buildings, and other structures required to perform program activities.

**species of concern** – Plants identified by the Washington Natural Heritage Program as sensitive (vulnerable or declining and could become endangered or threatened), Review 1 (more field work needed), or Review 2 (unresolved taxonomic problems). See also endangered species and threatened species. The federal listings classify species as listed (endangered/threatened), candidate, or proposed.

**stabilization** – Mixing an agent such as Portland cement with the waste to increase the mechanical strength of the resulting waste form and decrease its leachability.

**standard (packaging)** – Standard waste packages refer to the common forms of waste packages (such as drums and boxes) used for low-level waste and mixed low-level waste. See also non-standard (packaging).

**stochastic analysis** – Set of calculations performed using values randomly selected from a range of reasonable values for one or more parameters; in contrast, see deterministic analysis. In the HSW EIS, the median value was reported.

**stochastic variability** – Natural variation of a measured quantity; for example, in a room full of people, there is an average height with some being taller and some shorter; the stochastic variability of that group is described by the differences between the individuals' heights and the average.

**storage** – The holding of waste for a temporary period, at the end of which the waste is treated, disposed of, or stored elsewhere.

**taxa** – Plural of taxon.

**taxon** – A group of organisms sharing common characteristics in varying degrees of distinction that constitute one of the categories of taxonomic classification, such as a phylum, class, order, family, genus, or species.

**TEEL-1** – The maximum concentration in air below which it is believed nearly all individuals could be exposed without experiencing other than mild transient adverse health effects or perceiving a clearly defined objectionable odor.

**TEEL-2** – The maximum concentration in air below which it is believed nearly all individuals could be exposed without experiencing or developing irreversible or other serious health effects or symptoms that could impair their abilities to take protective action.

**TEEL-3** – The maximum concentration in air below which it is believed nearly all individuals could be exposed without experiencing or developing life-threatening health effects.

**threatened species** – Any plants or animals that are likely to become endangered species within the foreseeable future throughout all or a significant portion of their ranges, and which have been listed as threatened by the U.S. Fish and Wildlife Service or the National Marine Fisheries Service following the procedures set out in the Endangered Species Act and its implementing regulations (50 CFR 424).<sup>(a)</sup> Washington State defines threatened species as any wildlife species native to the state of Washington that is likely to become an endangered species within the foreseeable future throughout a significant portion of its range within the state (WAC 232-12-297).<sup>(b)</sup> See also candidate species and endangered species.

**teleost fish** – Of or belonging to the Teleostei or Teleostomi, a large group of fishes with bony skeletons, including most common fishes. The teleosts are distinct from the cartilaginous fishes such as sharks, rays, and skates.

**total recordable cases (TRCs)** – Work-related deaths, illnesses, or injuries resulting in loss of consciousness, restriction of work or motion, transfer to another job, or required medical treatment beyond first aid.

**Toxic Substances Control Act (TSCA) waste** – Any waste, including polychlorinated biphenyl commingled waste, regulated under the TSCA requirements codified in 40 CFR 761.<sup>(c)</sup>

**toxicological impact** – Impact on human health, due to exposure to, or intake of, chemical materials. These impacts are typically described in terms of damage to affected organs.

**transportation index (TI) of the package or packages** – is defined as the highest package dose rate (mrem per hour) that would be received by an individual located at a distance of 1 m (3.3 ft) from the external surface of the package.

---

(a) 50 CFR 424. “Listing Endangered and Threatened Species and Designating Critical Habitat.” Code of Federal Regulations. Online at: [http://www.access.gpo.gov/nara/cfr/waisidx\\_01/50cfr424\\_01.html](http://www.access.gpo.gov/nara/cfr/waisidx_01/50cfr424_01.html)

(b) WAC 232-12-297. “Endangered, threatened, and sensitive wildlife species classification.” Washington Administrative Code, Olympia, Washington. Online at: <http://www.leg.wa.gov/wac/index.cfm?fuseaction=Section&Section=232-12-297>

(c) 40 CFR 761. “Polychlorinated Biphenyls (PCBs) Manufacturing, Processing, Distribution In Commerce, and Use Prohibitions.” Code of Federal Regulations. Online at: [http://www.access.gpo.gov/nara/cfr/waisidx\\_01/40cfr761\\_01.html](http://www.access.gpo.gov/nara/cfr/waisidx_01/40cfr761_01.html)

**transuranic isotope** – Isotopes of any element having an atomic number greater than 92 (the atomic number of uranium).

**transuranic (TRU) waste** – Transuranic waste is radioactive waste containing more than 100 nanocuries (3700 becquerels) of alpha-emitting transuranic isotopes per gram of waste, with half-lives greater than 20 years, except for the following:

- high-level radioactive waste
- waste that the Secretary of Energy has determined, with the concurrence of the Administrator of the Environmental Protection Agency, does not need the degree of isolation required by the 40 CFR Part 191 disposal regulations
- waste that the Nuclear Regulatory Commission has approved for disposal on a case-by-case basis in accordance with 10 CFR 61.<sup>(a)</sup>

For the purposes of this document TRU waste may also include hazardous constituents, and may be referred to in the document as mixed TRU waste.

**treatment** – The physical, chemical, or biological processing of dangerous waste to make such waste non-dangerous or less dangerous, safer for transport, amenable for energy or material resource recovery, amenable for storage, or reduced in volume, with the exception of compacting, repackaging, and sorting as allowed under WAC 173-303-400<sup>(b)</sup> and 173-303-600.<sup>(b)</sup>

**Tri-Party Agreement (TPA)** – Informal title for the “Hanford Federal Facility Agreement and Consent Order,” an agreement between the U.S. Department of Energy, the U.S. Environmental Protection Agency, and the Washington State Department of Ecology. The agreement establishes milestones to bring operating DOE facilities into compliance with the RCRA, and to coordinate cleanup of Hanford’s inactive disposal sites under the Comprehensive Environmental Response, Compensation, and Liability Act (CERCLA).

**vadose zone** – The soil layer between the ground surface and the top of the saturated zone.

**waste characterization** – The identification of waste composition and properties, whether by review of process knowledge, or by non-destructive examination, non-destructive assay, or sampling and analysis, to determine appropriate storage, treatment, handling, transportation, and disposal requirements.

**waste certification** – A process by which a waste generator certifies that a given waste or waste stream meets the waste acceptance criteria of the facility to which the generator intends to transfer waste for treatment, storage, or disposal.

---

(a) 10 CFR 61. “Licensing Requirements for Land Disposal of Radioactive Waste.” Code of Federal Regulations. Online at: [http://www.access.gpo.gov/nara/cfr/waisidx\\_02/10cfr61\\_02.html](http://www.access.gpo.gov/nara/cfr/waisidx_02/10cfr61_02.html)

(b) WAC 173-303. “Dangerous Waste Regulations.” Washington Administrative Code, Olympia, Washington. Online at: <http://www.leg.wa.gov/wac/index.cfm?fuseaction=chapterdigest&chapter=173-303>

**waste container** – Any portable device in which a material is stored, transported, treated, disposed, or otherwise handled (WAC 173-303-400<sup>(b)</sup>). A waste container may include any liner or shielding material that is intended to accompany the waste in disposal. At Hanford, waste containers typically consist of 55-gal (208-L) or 85-gal (320-L) drums and standard waste boxes. Other sizes and styles of containers may also be employed depending on the physical, radiological, and chemical characteristics of the waste.

**waste disposal** – See disposal.

**waste life cycle** – The life of a waste from generation through storage, treatment, transportation, and disposal.

**waste stream** – A waste or group of wastes from a process or a facility with similar physical, chemical, or radiological properties. In the context of this document, a waste stream is defined as a collection of wastes with physical and chemical characteristics that will generally require the same management approach (that is, use of the same storage, treatment, and disposal capabilities).

**waste type** – In the context of this document, four waste types managed by the solid waste program are defined: low-level waste, mixed low-level waste, transuranic waste, and waste treatment plant waste (ILAW and melters).

**Watch List species** – A category of plant species of concern as identified by the Washington Natural Heritage Program. Watch List species consist of those plant taxa of concern that are more abundant and/or less threatened than previously assumed.

## **Glossary of Terms Related to Radioactivity, Radiation Dose, and Exposure**

**absorbed dose** – The energy absorbed by matter from ionizing radiation per unit mass of irradiated material at the place of interest in that material. The absorbed dose is expressed in units of rad (or gray) (1 rad = 0.01 gray = 100 ergs/gram of material).

**activity** – A measure of the quantity of a radioactive material, the special unit of which is the curie and the SI unit is the becquerel.

**becquerel (Bq)** – A unit of activity equal to 1 disintegration per second.

**collective dose** – The sum of the total effective dose equivalent values for all individuals in a specified population. Collective dose is expressed in units of person-rem (or person-sievert).

**committed dose equivalent** – The dose equivalent calculated to be received by a tissue or organ over a 50-year period after the intake of a radionuclide into the body. It does not include contributions from radiation sources external to the body. Committed dose equivalent is expressed in units of rem (or sievert).

**committed effective dose equivalent** – The sum of the committed dose equivalents to various tissues in the body, each multiplied by the appropriate weighting factor. Committed effective dose equivalent is expressed in units of rem (or sievert).

**curie (Ci)** – A unit of activity equal to 37 billion disintegrations per second, or 37 billion becquerels.

**dose (radiological)** – A generic term meaning absorbed dose, dose equivalent, effective dose equivalent, committed dose equivalent, or total effective dose equivalent, as defined elsewhere in this glossary.

**dose equivalent** – The product of absorbed dose in rad (or gray) in tissue, a quality factor, and other modifying factors. Dose equivalent is expressed in units of rem (or sievert).

**effective dose equivalent** – The summation of the products of the dose equivalent received by specified tissues of the body and the appropriate weighting factor. It includes the dose from radiation sources internal and external to the body. The effective dose equivalent is expressed in units of rem (or sievert).

**external dose or exposure** – The portion of the dose equivalent received from radiation sources outside the body (i.e., “external sources”).

**half-life (radiological)** – The time in which one-half of the atoms of a specific radionuclide decay into another nuclear form or energy state. Half-lives for different radionuclides range from fractions of a second to billions of years.

**gray** – The SI (International System of Units) unit of absorbed dose. One gray (Gy) is equal to an absorbed dose of 1 joule/kg (1 Gy = 100 rads). (The joule in the SI unit of energy, abbreviated as J, and is equivalent to 10 million ergs.)

**internal dose** – That portion of the dose equivalent received from radioactive material taken into the body (i.e., “internal sources”).

**millirem (mrem)** – A subunit of a rem. One mrem equals 1/1000<sup>th</sup> (0.001) of a rem.

**person-rem** – Unit of collective total effective dose equivalent.

**quality factor** – The principal modifying factor used to calculate the dose equivalent from the absorbed dose; the absorbed dose (expressed in rad or gray) is multiplied by the appropriate quality factor. The quality factors to be used for determining dose equivalent in rem are shown in the following table:

Radiation type	Quality factor
X-rays, gamma rays, positrons, electrons (including tritium beta particles).....	1
Neutrons, < 10 keV.....	3
Neutrons, > 10 keV.....	10
Protons and singly-charged particles of unknown energy with rest mass greater than one atomic mass unit.....	10
Alpha particles and multiple-charged particles (and particles of unknown charge) of unknown energy.....	20
When spectral data are insufficient to identify the energy of the neutrons, a quality factor of 10 shall be used.	

(ii) When spectral data are sufficient to identify the energy of the neutrons, the following mean quality factor values may be used:

Quality Factors for Neutrons

[Mean quality factors, Q (maximum value in a 30-cm dosimetry phantom), and values of neutron flux density that deliver in 40 hours, a maximum dose equivalent of 100 mrem (0.001 sievert).]

Neutron energy (MeV)	Mean quality factor	Neutron flux density (cm <sup>2</sup> s <sup>-1</sup> )
2.5 x 10 <sup>-8</sup> thermal.....	2	680
1 x 10 <sup>-7</sup> .....	2	680
1 x 10 <sup>-6</sup> .....	2	560
1 x 10 <sup>-5</sup> .....	2	560
1 x 10 <sup>-4</sup> .....	2	580
1 x 10 <sup>-3</sup> .....	2	680
1 x 10 <sup>-2</sup> .....	2.5	700
1 x 10 <sup>-1</sup> .....	7.5	115
5 x 10 <sup>-1</sup> .....	11	27
1.....	11	19
2.5.....	9	20
5.....	8	16
7.....	7	17
10.....	6.5	17
14.....	7.5	12
20.....	8	11
40.....	7	10
60.....	5.5	11
1 x 10 <sup>2</sup> .....	4	14
2 x 10 <sup>2</sup> .....	3.5	13
3 x 10 <sup>2</sup> .....	3.5	11
4 x 10 <sup>2</sup> .....	3.5	10

(a) Source: 10 CFR 835.

**rad** – A unit of radiation absorbed dose (such as, in body tissue). One rad is equal to an absorbed dose of 0.01 joule/kg (1 rad = 0.01 gray).

**radiation** – In the context of this EIS a simplified term for ionizing radiation such as alpha particles, beta particles, gamma rays, X-rays, neutrons, high-speed electrons, high-speed protons, and other particles capable of producing ions.

**radioactive decay** – The decrease in the amount of any radioactive material with the passage of time, due to spontaneous nuclear disintegration (e.g., emission from atomic nuclei of charged particles, photons, or both).

**radioactivity** – The property or characteristic of radioactive material to spontaneously “disintegrate” or “decay” with the emission of energy in the form of radiation.

**rem** – The special unit of radiation effective dose equivalent (1 rem = 0.01 Sievert).

**roentgen (R)** – The special unit of X- or gamma- radiation exposure. One roentgen equals 2.58 x 10<sup>-4</sup> coulombs per kilogram of air.

**sievert (Sv)** – The SI (International System of Units) unit of radiation effective dose equivalent (1 Sv = 100 rem).

**total effective dose equivalent (TEDE)** – The sum of the effective dose equivalent (for external exposures) and the committed effective dose equivalent (for internal exposures). Total effective dose equivalent is expressed in units of rem (or sievert).

**weighting factor** – The fraction of the overall health risk, resulting from uniform, whole body irradiation, attributable to a specific tissue. The dose equivalent to each tissue is multiplied by the appropriate weighting factor to obtain the effective dose equivalent contribution from that tissue. The weighting factors are as follows:

Weighting Factors For Various Tissues<sup>(a)</sup>

Organs or tissues	Weighting factor
Gonads.....	0.25
Breasts.....	0.15
Red bone marrow.....	0.12
Lungs.....	0.12
Thyroid.....	0.03
Bone surfaces.....	0.03
Remainder <sup>(b)</sup> .....	0.30
Whole body <sup>(c)</sup> .....	1.00

(a) Source: 10 CFR 835.

(b) "Remainder" means the five other organs or tissues with the highest dose (for example, liver, kidney, spleen, thymus, adrenal, pancreas, stomach, small intestine, and upper large intestine). The weighting factor for each remaining organ or tissue is 0.06.

(c) For the case of uniform external irradiation of the whole body, a weighting factor equal to 1 may be used in determination of the effective dose equivalent.



# Units of Measure

The principal units of measurement used in the HSW EIS are SI units, an abbreviation for the International System of Units, a metric system accepted by the International Organization of Standardization as the legal standard at a meeting in Elsinore, Denmark, in 1966. In this system, most units are made up of combinations of six basic units, of which length in meters, mass in kilograms, and time in seconds are of most importance in the EIS. An exception is radiological units that use the common system (e.g., rem, millirem).

## Numerical (Scientific or Exponential) Notation

Numbers that are very small or very large are often expressed in scientific or exponential notation as a matter of convenience. For example, the number 0.000034 may be expressed as  $3.4 \times 10^{-5}$  or 3.4E-05 and 65,000 may be expressed as  $6.5 \times 10^4$  or 6.5E+04. In the EIS, numerical values less than 0.001 or greater than 9999 are generally expressed in exponential notation, or 1.0E-03 and 9.9E+03, respectively.

Multiples or sub-multiples of the basic units are also used. A partial list of prefixes that denote multiples and sub-multiples follows, with the equivalent multiplier values expressed in scientific and exponential notation:

Name	Symbol	Value Multiplied by:		
atto	a	0.000000000000000001	or $1 \times 10^{-18}$	or 1E-18
femto	f	0.000000000000001	or $1 \times 10^{-15}$	or 1E-15
pico	p	0.000000000001	or $1 \times 10^{-12}$	or 1E-12
nano	n	0.000000001	or $1 \times 10^{-9}$	or 1E-09
micro	$\mu$	0.000001	or $1 \times 10^{-6}$	or 1E-06
milli	m	0.001	or $1 \times 10^{-3}$	or 1E-03
centi	c	0.01	or $1 \times 10^{-2}$	or 1E-02
kilo	k	1,000	or $1 \times 10^3$	or 1E+03
mega	M	1,000,000	or $1 \times 10^6$	or 1E+06
giga	G	1,000,000,000	or $1 \times 10^9$	or 1E+09
tera	T	1,000,000,000,000	or $1 \times 10^{12}$	or 1E+12

The following symbols are occasionally used in conjunction with numerical expressions: < less than;  $\leq$  less than or equal to; > greater than;  $\geq$  greater than or equal to.

In some cases, numerical values in this document have been rounded to an appropriate number of significant figures to reflect the accuracy of data being presented. For example, the numbers 0.021, 21, 2100, and 2,100,000 all contain 2 significant figures. In some cases, where several values are summed to obtain a total, the rounded total may not exactly equal the sum of its rounded component values.

## Basic Units and Conversion Table

Unit of Measure	English Unit	Symbol	Metric Unit	Symbol
Length	inches	in	centimeters	cm
	feet	ft	meters	m
	yards	yd	kilometers	km
	miles	mi		
Area	square feet	ft <sup>2</sup>	square meters	m <sup>2</sup>
	acres	ac	hectares	ha
	square miles	mi <sup>2</sup>	square kilometers	km <sup>2</sup>
Volume (dry)	cubic feet	ft <sup>3</sup>	cubic meters	m <sup>3</sup>
	cubic yards	yd <sup>3</sup>		
Volume (liquid)	gallons	gal	liters	L
Mass	ounces	oz	grams	g
	pounds	lb	kilograms	kg
Concentration	parts per million	ppm	grams per liter	g/L
Radioactivity	curies	Ci	becquerels	Bq
Radiation Absorbed Dose	rad	rad	Gray	Gy
Radiation Effective Dose Equivalent	rem	rem	Sievert	Sv
Temperature	degrees Fahrenheit	°F	degrees Centigrade	°C

Base Unit	Multiply By	To Obtain	Base Unit	Multiply By	To Obtain
in	2.54	cm	cm	0.394	in
ft	0.305	m	m	3.28	ft
yd	0.914	m	m	1.09	yd
mi	1.61	km	km	0.621	mi
ft <sup>2</sup>	0.093	m <sup>2</sup>	m <sup>2</sup>	10.76	ft <sup>2</sup>
ac	0.405	ha	ha	2.47	ac
mi <sup>2</sup>	2.59	km <sup>2</sup>	km <sup>2</sup>	0.386	mi <sup>2</sup>
ft <sup>3</sup>	0.028	m <sup>3</sup>	m <sup>3</sup>	35.3	ft <sup>3</sup>
yd <sup>3</sup>	0.765	m <sup>3</sup>	m <sup>3</sup>	1.31	yd <sup>3</sup>
gal	3.77	L	L	0.265	gal
oz	28.349	g	g	0.035	oz
lb	0.454	kg	kg	2.205	lb
ppm	0.001	g/L	g/L	1000	ppm
Ci	3.7 x 10 <sup>10</sup>	Bq	Bq	2.7 x 10 <sup>-11</sup>	Ci
rad	0.01	Gy	Gy	100	rad
rem	0.01	Sv	Sv	100	rem
°F	(°F - 32) x 5/9	°C	°C	(°C x 9/5) + 32	°F

## Radionuclide Nomenclature<sup>(a,b)</sup>

Symbol	Radionuclide	Half-Life	Symbol	Radionuclide	Half-Life
Ac-227*	actinium-227	22 yr	Pu-240	plutonium-240	6537 yr
Ag-110m	silver-110m	250 d	Pu-241	plutonium-241	14 yr
Am-241	americium-241	432 yr	Pu-242	plutonium-242	3.7 x 10 <sup>5</sup> yr
Ba-137m	barium-137m	2.6 min	Pu-244	plutonium-244	8.1 x 10 <sup>7</sup> yr
Be-7*	beryllium-7	53 d	Ra-224*	radium-224	3.7 d
Bi-212*	bismuth-212	61 min	Ra-226*	radium-226	1600 yr
Bi-214*	bismuth-214	20 min	Ra-228*	radium-228	5.8 yr
C-14*	carbon-14	5730 yr	Rb-87*	rubidium-87	4.8 x 10 <sup>10</sup> yr
Cd-113m*	cadmium-113m	15 yr	Rh-106	rhodium-106	30 sec
Ce-144	cerium-144	285 d	Ru-106	ruthenium-106	374 d
Cl-36	chlorine-36	3.0 x 10 <sup>5</sup> yr	Sb-125	antimony-125	2.8 yr
Cm-244	curium-244	18 yr	Sb-126m	antimony-126m	11 sec
Co-60	cobalt-60	5.3 yr	Se-75	selenium-75	120 d
Cs-137	cesium-137	30 yr	Se-79	selenium-79	6.5 x 10 <sup>5</sup> yr
Eu-152	europium-152	14 yr	Sm-147*	samarium-147	1.1 x 10 <sup>11</sup> yr
Eu-154	europium-154	8.6 yr	Sm-151	samarium-151	90 yr
Eu-155	europium-155	4.8 yr	Sn-126	tin-126	1.0 x 10 <sup>5</sup> yr
Fe-55	iron-55	2.7 yr	Sr-90	strontium-90	29 yr
H-3*	tritium	12 yr	Tc-99	technetium-99	2.1 x 10 <sup>5</sup> yr
I-125	iodine-125	59 d	Th-228*	thorium-228	1.9 yr
I-129	iodine-129	1.6 x 10 <sup>7</sup> yr	Th-229	thorium-229	7880 yr
K-40*	potassium-40	1.3 x 10 <sup>9</sup> yr	Th-230*	thorium-230	7.5 x 10 <sup>4</sup> yr
Mn-54	manganese-54	312 d	Th-232*	thorium-232	1.4 x 10 <sup>10</sup> yr
Mo-93	molybdenum-93	4000 yr	Th-234*	thorium-234	24 d
Nb-94	niobium-94	2.0 x 10 <sup>4</sup> yr	U-232	uranium-232	69 yr
Ni-59	nickel-59	7.6 x 10 <sup>4</sup> yr	U-233	uranium-233	1.6 x 10 <sup>5</sup> yr
Ni-63	nickel-63	100 yr	U-234*	uranium-234	2.5 x 10 <sup>5</sup> yr
Np-237	neptunium-237	2.1 x 10 <sup>6</sup> yr	U-235*	uranium-235	7.0 x 10 <sup>8</sup> yr
Pa-231*	protactinium-231	3.3 x 10 <sup>4</sup> yr	U-236	uranium-236	2.3 x 10 <sup>7</sup> yr
Pb-210*	lead-210	22 yr	U-238*	uranium-238	4.5 x 10 <sup>9</sup> yr
Pb-212*	lead-212	11 hr	W-185	tungsten-185	75 d
Pd-107	palladium-107	6.5 x 10 <sup>6</sup> yr	Y-90	yttrium-90	2.7 d
Pr-144	praseodymium-144	17 m	Zn-65	zinc-65	244 d
Pu-238	plutonium-238	88 yr	Zr-93	zirconium-93	1.5 x 10 <sup>6</sup> yr
Pu-239	plutonium-239	2.4 x 10 <sup>4</sup> yr	Zr-95	zirconium-95	64 d

(a) From *CRC Handbook of Chemistry and Physics*. 74th edition. ed. David R. Lide, CRC Press, Boca Raton, Florida 1993.

(b) Listing includes radionuclides evaluated in this document. Metastable isomers are indicated by the addition of an *m*. Short-lived decay products are not shown.

\* Indicates naturally occurring radionuclides.

## Reference Citations

Throughout the text of the HSW EIS, in-text reference citations are presented where information from the referenced document was used. These in-text reference citations are contained within parentheses and provide a brief identification of the referenced document. This brief identification corresponds to the complete reference citation located in the reference lists, which are located at the end of each section and appendix in the HSW EIS. The references are listed in alphabetical or numeric order and do not necessarily reflect the order of their appearance in the text.

An example of an in-text reference citation is (DOE 1997a), which corresponds to the complete reference citation provided in section or appendix reference lists. In the reference list, DOE 1997a, DOE 1997b, and DOE 1997c are listed in the following manner (based on the alphabetical order of the document title, not the order in which they might appear in the text):

DOE. 1997a. *Final Waste Management Programmatic Environmental Impact Statement for Managing Treatment, Storage, and Disposal of Radioactive and Hazardous Waste*. DOE/EIS-0200-F, U.S. Department of Energy, Washington, D.C.

DOE. 1997b. *Integrated Data Base Report – 1996: U.S. Spent Nuclear Fuel and Radioactive Waste Inventories, Projections, and Characteristics*. DOE/RW-0006, Rev. 13, U.S. Department of Energy, Office of Environmental Management, Washington, D.C.

DOE. 1997c. *Waste Isolation Pilot Plant Disposal Phase Final Supplemental Environmental Impact Statement*. DOE/EIS-0026-S-2, U.S. Department of Energy, Carlsbad Area Office, Carlsbad, New Mexico.

# 1.0 Introduction

This *Hanford Site Solid<sup>(a)</sup> (Radioactive and Hazardous) Waste Program Environmental Impact Statement* (HSW EIS) provides environmental and technical information concerning U.S. Department of Energy (DOE) ongoing and proposed waste management practices at the Hanford Site in Washington State. The HSW EIS updates some analyses of environmental consequences from previous documents and provides evaluations for activities that may be implemented consistent with the Waste Management Programmatic Environmental Impact Statement (WM PEIS; DOE 1997c) Records of Decision (RODs). The draft HSW EIS was initially issued in April 2002 for public comment (DOE 2002b). A revised draft HSW EIS was issued in March 2003 to address new waste management alternatives that had been proposed since the initial draft HSW EIS was prepared, and to address comments received during the public review period for the first draft (DOE 2003d). The revised draft HSW EIS also incorporated alternatives for disposal of immobilized low-activity waste (ILAW) from treatment of Hanford Site tank waste in the waste treatment plant (WTP) currently under construction, an activity that was not included in the first draft (68 FR 7110).

This final HSW EIS describes the DOE preferred alternative, and in response to public comments received on the March 2003 revised draft, provides additional analyses for some environmental consequences associated with the preferred alternative, with other alternatives, and with cumulative impacts.<sup>(b)</sup> Public comments on the revised draft HSW EIS are addressed in the comment response document (Volume III of this final EIS).

This HSW EIS describes the environmental consequences of alternatives for constructing, modifying, and operating facilities to store, treat, and/or dispose of low-level (radioactive) waste (LLW), transuranic (TRU) waste, ILAW, and mixed low-level waste (MLLW) including WTP melters at Hanford. In addition, the potential long-term consequences of LLW, MLLW, and ILAW disposal on groundwater and surface water are evaluated for a 10,000-year period, although the DOE performance standards only require assessment for the first 1000 years after disposal (DOE 2001f). This document does not address non-radioactive waste that contains “hazardous” or “dangerous” waste, as defined under the Resource Conservation and Recovery Act (RCRA) of 1976 (42 USC 6901) and Washington State Dangerous Waste regulations (WAC 173-303). Following a previous National Environmental Policy Act (NEPA, 42 USC 4321) review (DOE 1997d), DOE decided to dispose of TRU waste in New Mexico at the Waste Isolation Pilot Plant (WIPP), a repository that meets the requirements of 40 CFR 191 (63 FR 3623). This HSW EIS has been prepared in accordance with NEPA, the DOE implementing procedures for NEPA

- 
- (a) The term “solid waste” is used to denote that the focus of this EIS is upon radioactive waste in solid form rather than liquid waste. It is not synonymous with the usage of the term “solid waste” in the Resource Conservation and Recovery Act (RCRA).
- (b) The final HSW EIS is based on the revised draft HSW EIS. Substantive changes (additions, deletions, and modifications) to the document are indicated with “change bars” in the margins of the affected pages. These change bars indicate additional or revised information since the publication of the revised draft HSW EIS, including information based on revised analyses, and in response to public comments. Changes that were editorial in nature are not indicated.

(10 CFR 1021), and the Council on Environmental Quality (CEQ) Regulations for Implementing the Procedural Provisions of NEPA (40 CFR 1500-1508).

## 1.1 Organization of the HSW EIS

The organization and content of this HSW EIS are described briefly as follows:

- **Volume I** – Consists of the main document that describes the background, alternatives, affected environment, environmental consequences, regulatory framework, and other related sections, as follows:
  - **Section 1 – Introduction:** Provides an introduction, organization of the EIS, a statement of the purpose and need for DOE action and description of the proposed action, an overview of Hanford Site cleanup operations including solid radioactive and mixed waste management activities, a discussion of related DOE programs and documents including Hanford’s accelerated cleanup performance management plan, NEPA documents related to the HSW EIS, and the NEPA process for developing and finalizing the HSW EIS.
  - **Section 2 – HSW EIS Waste Streams and Waste Management Facilities:** Describes Hanford waste management operations, waste types, waste streams, existing facilities, and facilities related to the proposed action and alternatives.
  - **Section 3 – Description and Comparison of Alternatives:** Describes alternative actions that could be taken at Hanford to manage solid radioactive and mixed waste (waste that contains both radioactive and hazardous constituents), including alternative management strategies for each waste type, and the No Action Alternative. This section also provides a comparison of environmental impacts among the alternatives.
  - **Section 4 – Affected Environment:** Discusses the human and physical environment that might be affected by radioactive and mixed waste management operations at Hanford.
  - **Section 5 – Environmental Consequences:** Identifies the potential impacts on the human and physical environment that might result from implementation of the alternatives for waste management at Hanford. This section also addresses environmental justice, cumulative impacts, irreversible and irretrievable commitment of resources, the relationship between short-term uses of the environment and the maintenance or enhancement of long-term productivity, and potential mitigation measures.
  - **Section 6 – Regulatory Framework:** Identifies regulations and permits that apply to radioactive and mixed waste management operations at Hanford.
  - **Section 7 – List of Preparers and Contributors:** Identifies key persons who contributed to the preparation of the HSW EIS.

- **Index** – Provides an alphabetized list of key names, terms, and subjects in this EIS and the sections in which each item is mentioned.
- **Volume II Appendixes** – Provides additional information regarding specific sections of the EIS and discusses key issues identified during the scoping process for the HSW EIS.
- **Volume III Comment Response Document** – explains DOE’s role in the cleanup process at Hanford; discusses key issues raised during the public comment process for the revised draft HSW EIS, including changes incorporated into this final HSW EIS in response to comments. Comments from federal agencies; state, local, and tribal governments; public and private organizations; and individuals are summarized, and DOE responses to those comments are provided.
- **Volume IV Submitted Comment Documents and Transcripts** – contains copies of comment letters and other comments submitted in writing, as well as transcripts of public meetings, for the revised draft HSW EIS.

## 1.2 Purpose and Need and Proposed Action

DOE needs to provide capabilities to continue, or modify, the way it treats, stores, and/or disposes of existing and anticipated quantities of solid LLW, MLLW, TRU waste, and ILAW at the Hanford Site in order to protect human health and the environment; facilitate cleanup at Hanford and other DOE facilities; take actions consistent with decisions reached by DOE under the WM PEIS; comply with local, state, and federal laws and regulations; and meet other obligations such as the Hanford Federal Facility Agreement and Consent Order (also referred to as the Tri-Party Agreement, or TPA) (Ecology et al. 1989).

To address anticipated needs for waste management capabilities, DOE proposes to do the following:

- continue to operate and modernize existing treatment, storage, and disposal facilities for LLW and MLLW, and treatment and storage facilities for TRU waste
- construct additional disposal capacity for LLW
- develop capabilities to treat MLLW for disposal at Hanford
- construct additional disposal capacity for MLLW
- construct disposal capacity for ILAW and WTP melters<sup>(a)</sup>
- close onsite disposal facilities and provide for post-closure stewardship of disposal sites
- develop additional capabilities to certify TRU waste for disposal at WIPP.

---

(a) On July 3, 2003, parts of DOE Order 435.1 dealing with the procedures for determining waste incidental to reprocessing were declared invalid by the U.S. District Court for the District of Idaho in **Natural Resources Defense Council v. DOE**, No. 01-413-S-BLW. The District Court’s ruling is currently on appeal to the U.S. Court of Appeals for the Ninth Circuit. The ultimate outcome of this matter, and its impact or applicability to wastes addressed in this EIS, are uncertain. While this EIS evaluates the disposal, at Hanford, of ILAW and melter wastes meeting Hanford Site Solid Waste Acceptance Criteria, DOE would only proceed with disposal of these wastes if their disposal complies with applicable law.

Alternatives proposed to accomplish the purpose and need are described in Section 3. The No Action Alternative is also evaluated as required by NEPA. For purposes of analysis in this HSW EIS, the No Action Alternative is defined as continuing ongoing activities, or as implementing previous NEPA decisions where those activities have not commenced.

### 1.3 Overview of Hanford Site Operations and DOE Waste Management Activities

The Hanford Site occupies approximately 1517 km<sup>2</sup> (586 mi<sup>2</sup>), principally in Benton and Franklin counties of south-central Washington State (Figure 1.1). The Columbia River flows through the northern and eastern parts of the site, which extends about 46 km (25 mi) north from Richland, Washington. DOE and its predecessors, the Manhattan Project, the U.S. Atomic Energy Commission (AEC), and the U.S. Energy Research and Development Administration (ERDA), have operated the Hanford Site since the 1940s. From the beginning through the 1980s, the primary mission at Hanford was to produce nuclear materials in support of United States defense, research, and biomedical programs. Operations associated with those programs used facilities for fabrication of nuclear reactor fuel, reactors for nuclear materials production, chemical separation plants, nuclear material processing facilities, research laboratories, and waste management facilities. Plutonium production at Hanford has ceased, and DOE activities at the site currently include research, environmental restoration, and waste management. Additional historical information regarding the Hanford Site is available on the Internet at <http://www.hanford.gov>.

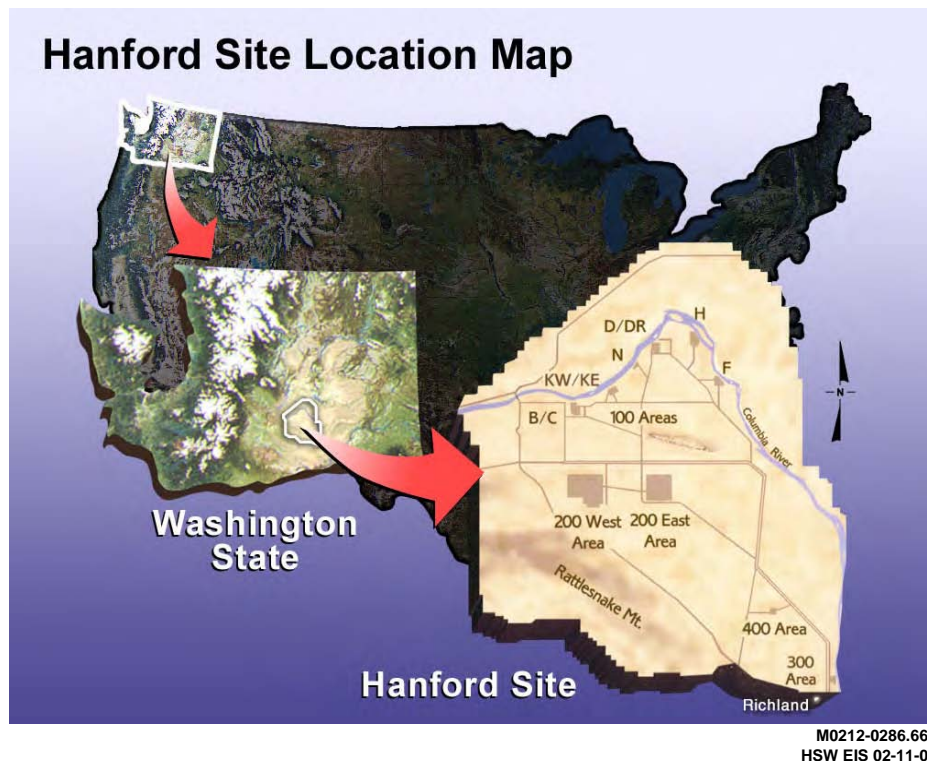


Figure 1.1. Hanford Site Location Map



In addition to the DOE activities at Hanford, there are several facilities operated by other agencies at the site. The Laser Interferometer Gravitational Wave Observatory (LIGO) is an advanced scientific observatory for measuring gravity waves at extremely low levels. The project involves the California Institute of Technology, the Massachusetts Institute of Technology, and the National Science Foundation. The Hanford Site was selected for the LIGO because of its available space and seismic stability. A commercial nuclear power plant, the Columbia Generating Station, also operates within the Hanford Site. That facility is located on property leased to Energy Northwest, a consortium of regional public utilities.

The largest non-DOE federal agency at Hanford is the U.S. Fish and Wildlife Service, which co-manages with DOE the 195,000-acre Hanford Reach National Monument, which was established by presidential proclamation on June 9, 2000. The monument includes the Fitzner/Eberhardt Arid Lands Ecology Reserve (ALE), Saddle Mountain Wildlife Refuge, Wahluke Slope, White Bluffs, the sand dune area northwest of the Energy Northwest Site, historic structures (including homesteads from small towns established along the riverbanks in the early 20<sup>th</sup> century), and land 0.4 km (¼ mi) inland on the south and west shores of the 82-km (51-mi) long Hanford Reach, the last free-flowing, non-tidal stretch of the Columbia River. Also included were the McGee Ranch and Riverlands area and the federally owned islands within that portion of the Columbia River.

US Ecology, Inc. operates a commercial low-level radioactive waste disposal facility on 40.5 hectares (100 acres) of the Hanford Site near the 200 East Area leased by the State of Washington from DOE. The facility is licensed by the U.S. Nuclear Regulatory Commission (NRC) and the State of Washington, not DOE. The US Ecology facility is one of three commercial LLW disposal facilities in the United States. It currently accepts waste from two state compacts established to manage radioactive waste from nuclear power plants and other commercial facilities: the Northwest Compact (Washington, Idaho, Oregon, Montana, Wyoming, Utah, Alaska, and Hawaii) and the Rocky Mountain Compact (Colorado, Nevada, and New Mexico). Waste is received from hospitals, universities, research facilities, commercial nuclear power operations, and other industries within the compact states. The reactor vessel from the Trojan plant, a commercial nuclear power reactor in Oregon, was buried at the site during 2000. Of the total waste receipts at the facility between 1996 and 2001, the state of Oregon accounted for the largest share by volume (65%) and by radioactivity (95%).

### **1.3.1 DOE National Waste Management**

When DOE established the Office of Environmental Management (EM) in 1989, it defined cleanup of DOE sites as a top priority and committed itself to addressing the challenges of waste management. EM is responsible for waste management activities at all DOE sites, including Hanford, and needs to address them on a nationwide basis. This section provides an overview of DOE nationwide plans for management of radioactive and hazardous waste, including waste from the Hanford Site. Figure 1.2 shows the nationwide distribution of states in which one or more types of DOE radioactive waste are, or will be, disposed of, including LLW, MLLW, environmental restoration waste, TRU waste, HLW, SNF, and uranium mill tailings. The DOE nationwide strategy for managing radioactive, hazardous, and mixed waste is provided by the WM PEIS (DOE 1997c) and associated Records of Decision (RODs) (63 FR 3629, 63 FR 41810, 64 FR 46661, 65 FR 10061, 65 FR 82985, 66 FR 38646, 67 FR 56989). Other NEPA documents related to those activities are discussed in Section 1.5.

### 1.3.1.1 Spent Nuclear Fuel and High-Level Waste

DOE is required by *The Nuclear Waste Policy Act of 1982*, as amended (42 USC 10101) to provide disposal capacity for spent nuclear fuel (SNF) generated by commercial nuclear power plants and DOE, as well as high-level waste (HLW) generated by atomic energy and defense activities. Spent nuclear fuel is fuel that has been irradiated in a reactor but has not been processed to separate potentially useful materials. High-level waste consists of certain process residues (liquids, solids, or sludges) that result from processing irradiated reactor fuel to recover plutonium and uranium. DOE sites that currently manage HLW and spent nuclear fuel are in the process of stabilizing and storing those materials until a permanent disposal facility is available. DOE is now preparing an application to the Nuclear Regulatory Commission to obtain a license to proceed with constructing a repository for disposal of HLW and SNF at Yucca Mountain in Nevada. The repository is scheduled to open around 2010.

#### **Spent Nuclear Fuel (SNF)**

Fuel that has been irradiated in a nuclear power plant or other reactor. Spent fuel is generally thermally hot and highly radioactive.

#### **High-Level Waste (HLW)**

High-level waste is the highly radioactive waste material that results from processing of spent nuclear fuel, including liquid waste produced directly in processing and any solid material derived from such liquid waste that contains fission products in sufficient concentrations, and other highly radioactive material that is determined, consistent with existing law, to require isolation.

### 1.3.1.2 Transuranic Waste

DOE has a repository for disposal of TRU waste in New Mexico at WIPP. WIPP opened in 1999 and received the first shipments of TRU waste from Hanford in 2000. As of December 2003, about 415 m<sup>3</sup> (14,650 ft<sup>3</sup>) of TRU waste from Hanford has been sent to WIPP. Since 1993, about 10.4 m<sup>3</sup> (367 ft<sup>3</sup>) of TRU waste has also been sent to Hanford from other DOE sites for temporary storage, and to take advantage of existing and planned capabilities to process and certify TRU waste for disposal at WIPP. All TRU waste sent to Hanford will be shipped to WIPP.

#### **Transuranic (TRU) Waste**

Transuranic waste is radioactive waste containing more than 100 nanocuries (3700 becquerels) of alpha-emitting transuranic isotopes per gram of waste, with half-lives greater than 20 years, except for the following:

- high-level radioactive waste
- waste that the Secretary of Energy has determined, with the concurrence of the Administrator of the Environmental Protection Agency, does not need the degree of isolation required by the 40 CFR Part 191 disposal regulations
- waste that the Nuclear Regulatory Commission has approved for disposal on a case-by-case basis in accordance with 10 CFR 61.

Adapted from DOE (2001f).

Some TRU waste may also contain hazardous components (mixed TRU waste) and would be managed under applicable state and federal hazardous waste regulations. For purposes of evaluation in the HSW EIS, mixed TRU waste has not been identified as a separate waste type from other TRU waste.

DOE's hazardous waste permit for WIPP, issued in 1999 by the State of New Mexico Environment Department, currently authorizes disposal of contact-handled mixed TRU waste.

### 1.3.1.3 Low-Level Waste and Mixed Low-Level Waste

DOE plans to continue treating and disposing of LLW and MLLW at facilities that currently have capabilities to manage those wastes (DOE 1997c; 65 FR 10061). Under that ROD, Hanford and the Nevada Test Site (NTS) will continue to receive LLW from other facilities that do not have the capacity to treat or dispose of it. Hanford and NTS were also identified as sites that could treat and dispose of MLLW from other sites. Regional MLLW treatment could also occur at the Idaho National Engineering and Environmental Laboratory (INEEL), the Oak Ridge Reservation (ORR), and the Savannah River Site (SRS), as well as at offsite commercial facilities. DOE sites also have the

option to send waste to commercial disposal facilities, such as Envirocare in Utah. Envirocare received over 56,000 m<sup>3</sup> (2,000,000) of DOE LLW and MLLW between 1993 and 2000 (Envirocare 2000a, b, c). DOE plans to continue shipping some LLW and MLLW to Envirocare. NTS received about 65,000 m<sup>3</sup> (2,300,000 ft<sup>3</sup>) of LLW during 2002 and expects to receive an additional 360,000 m<sup>3</sup> (13,000,000 ft<sup>3</sup>) through 2006. By comparison, existing forecasts through 2046 indicate that DOE's Hanford Solid Waste Program could receive up to 220,000 m<sup>3</sup> (7,800,000 ft<sup>3</sup>) of LLW and up to 140,000 m<sup>3</sup> (4,900,000 ft<sup>3</sup>) of MLLW from offsite DOE generators. Total LLW and MLLW annual volumes from offsite generators are not expected to exceed 45,000 m<sup>3</sup> (1,600,000 ft<sup>3</sup>).

The Tank Waste Remediation System (TWRS) EIS summarized formal discussions between DOE and NRC on tank waste classification and how the low-activity portion of the waste might be regulated (DOE and Ecology 1996). Although those consultations were carried out in the context of low-activity waste (LAW) disposal in a grout matrix (Kincaid et al. 1995), the logic was applied to vitrified LAW as well. Based on an NRC published opinion (Bernero 1993; 58 FR 12342), the TWRS EIS analysis concluded that the LAW stream could be classified as incidental waste and subjected to

#### ***Low-Level Waste (LLW)***

Low-level radioactive waste is radioactive waste that is not high-level radioactive waste, spent nuclear fuel, transuranic waste, byproduct material (as defined in Section 11e.(2) of the Atomic Energy Act of 1954, as amended), or naturally occurring radioactive material.

#### ***Mixed Low-Level Waste (MLLW)***

Mixed low-level waste is LLW that contains both radionuclides subject to the Atomic Energy Act of 1954, as amended (42 USC 2011), and a hazardous component subject to the Resource Conservation and Recovery Act or Washington State Dangerous Waste Regulations.

#### ***Low-Activity Waste (LAW)***

Low-activity waste is the waste that remains after separating from high-level waste as much of the radioactivity as practicable, and that when solidified may be disposed of as low-level waste in a near-surface facility.

#### ***Immobilized Low-Activity Waste (ILAW)***

Immobilized low-activity waste is the solidified low-activity waste from the treatment and immobilization of Hanford tank waste. The ILAW would be disposed of on the Hanford Site or at a qualified offsite facility.

disposal requirements for LLW. A second NRC review subsequent to the TWRS EIS indicated that the vitrified waste form selected in the ROD (62 FR 8693) also would provisionally meet criteria for classification as LAW, based on available information provided at that time (NRC 1997).

GTCC radioactive waste is low-level radioactive waste generated under a Nuclear Regulatory Commission (NRC) or agreement state license that exceeds the class C limits in 10 CFR 61, "Licensing Requirements for Land Disposal of Radioactive Waste." Part 61.55, "Waste Classification," defines class A, B, and C low-level waste. These waste types are defined by concentration of specific short- and long-lived radionuclides, with class C having the highest concentration limits.

Under the Low Level Radioactive Waste Policy Amendments Act of 1985, the federal government (e.g., DOE) is responsible for the disposal of commercial GTCC radioactive waste. To address its responsibilities under this Act, DOE is considering whether to propose establishing a capability to dispose of GTCC wastes. If DOE makes such a proposal it would prepare appropriate NEPA documentation, such as an environmental impact statement that analyzes alternative technologies and disposal sites. To ensure that it considers the full range of reasonable alternatives in any such EIS as required by NEPA, DOE would evaluate whether Hanford and other DOE sites would be reasonable alternatives for potential disposal of GTCC waste. Although the WM PEIS did not analyze GTCC waste, the Hanford Site was analyzed as a reasonable alternative for potential disposal of other low-level wastes.

### **1.3.2 DOE Waste Management Activities at Hanford**

Waste generated by past Hanford Site activities contains a variety of radionuclides and non-radioactive hazardous constituents. Those materials range from highly radioactive wastes that must be managed in specialized facilities to less radioactive waste that can be managed by more conventional means, such as shallow land disposal. EM activities at the Hanford Site involve radioactive waste and other radioactive materials. These wastes and materials require different management approaches depending on their specific characteristics, location, and legal and regulatory requirements.

DOE's waste management policy includes reducing the hazards of waste to people and the environment by minimizing generation of new waste, by treating waste, by placing waste in safer configurations, and by removing waste from environmentally sensitive areas, such as along the Columbia River.

The Hanford programs for spent nuclear fuel, HLW, environmental restoration, liquid waste and groundwater protection are covered under other NEPA and Comprehensive Environmental Response, Compensation, and Liability Act (CERCLA, 42 USC 9601) reviews. However, they influence the analyses in this HSW EIS as generators of waste that would ultimately be managed under the resulting decisions. The relationship of the HSW EIS to the major EM activities at the Hanford Site is outlined here (see Volume II, Appendix N for additional information):

- **K Basin Sludge:** Sludge generated during removal of spent fuel and cleanout of the K Basins would be stored at T Plant until a facility is available to process and certify it for shipment to WIPP. In addition, LLW, MLLW, and TRU waste may be generated during activities at the K Basins.

- Tank waste treatment: ILAW and melters from the WTP would be disposed of in near-surface facilities at Hanford. Waste from WTP operations would also require disposal, including equipment removed from tanks during retrieval of the tank waste, and waste generated during operation of the WTP.
- Environmental restoration activities: TRU waste retrieved during CERCLA cleanup of the 618-10 and 618-11 Burial Grounds would be processed and certified for shipment to WIPP, and other operational waste from cleanup activities may require treatment and disposal. The Environmental Restoration Disposal Facility (ERDF) may also be selected as a potential disposal site for LLW, MLLW, WTP melters, and ILAW. Under DOE policy, NEPA values are integrated into the CERCLA process prior to making remediation decisions (DOE 1994).
- Liquid waste: Leachate from lined disposal trenches would be treated at the Effluent Treatment Facility (ETF), and some solids from ETF would be returned to the Low Level Burial Grounds (LLBGs) for disposal. Other operational waste generated during liquid waste treatment may also be disposed of at Hanford.

### **1.3.2.1 Groundwater Protection**

Groundwater in the unconfined aquifer beneath the Hanford Site ultimately surfaces at springs near or in the Columbia River, which traverses the northern and eastern parts of the site. Some of the groundwater is contaminated by radionuclides and hazardous chemicals as a result of past liquid disposal practices, leaks, and spills.

The past practice of discharging untreated liquid waste to the ground decreased through the 1980s and was discontinued in 1995. Within the 200 Area plateau, two state-permitted discharge sites still exist: the 200 Area Treated Effluent Disposal Facility and the State-Approved Land Disposal Structure (SALDS). Tritiated water is discharged at the SALDS in accordance with DOE Order 5400.5 (DOE 1993). There is no practicable technology available for removing tritium from dilute liquid waste streams. Currently, DOE uses the long transit time in groundwater from the discharge point to the Columbia River to allow tritium to decay. Allowing the tritium to decay in the groundwater while isolated from public use is an acceptable alternative to direct release to the atmosphere or to surface water.

Programs are under way to stabilize and clean up remaining materials, soil, and groundwater plumes that could present a threat to human health and the environment in the future. Ongoing radioactive and hazardous waste management practices comply with applicable standards, and they are evaluated on a continuing basis to minimize environmental degradation. Groundwater monitoring at Hanford is being addressed under milestones established by the TPA independently of this HSW EIS. Groundwater monitoring requirements would apply to any actions DOE may decide to implement as a result of the analyses conducted under this HSW EIS.

DOE and a team of contractors have developed, and are implementing, a sitewide program that integrates all assessment and remediation activities that address key groundwater, vadose zone, and related Columbia River issues. This effort is coordinated by the Groundwater Protection Program to

support cleanup and closure decisions for the Hanford Site and protection of the Columbia River. General information regarding Hanford's Groundwater Protection Program can be found in Volume II, Appendix N and at <http://www.hanford.gov/cp/gpp>. Information developed under that program was used to evaluate long-term impacts of LLW and MLLW disposal in this HSW EIS.

### **1.3.2.2 The Tri-Party Agreement**

Beginning in 1986, DOE, the U.S. Environmental Protection Agency (EPA), and the Washington State Department of Ecology (Ecology) began to examine how best to bring the Hanford Site into compliance with RCRA, CERCLA, and applicable state hazardous waste regulations. The regulatory agencies and DOE agreed to develop one compliance agreement establishing milestones for conducting Hanford Site cleanup activities under CERCLA and for bringing operating facilities into compliance with RCRA. Negotiations concluded in late 1988, and the TPA was signed by the three participating agencies on January 15, 1989 (Ecology et al. 1989). The TPA includes a process for revising milestones by mutual agreement of the agencies. Milestones established under the TPA influence some activities proposed in this HSW EIS. The TPA is discussed further in Section 6.3.

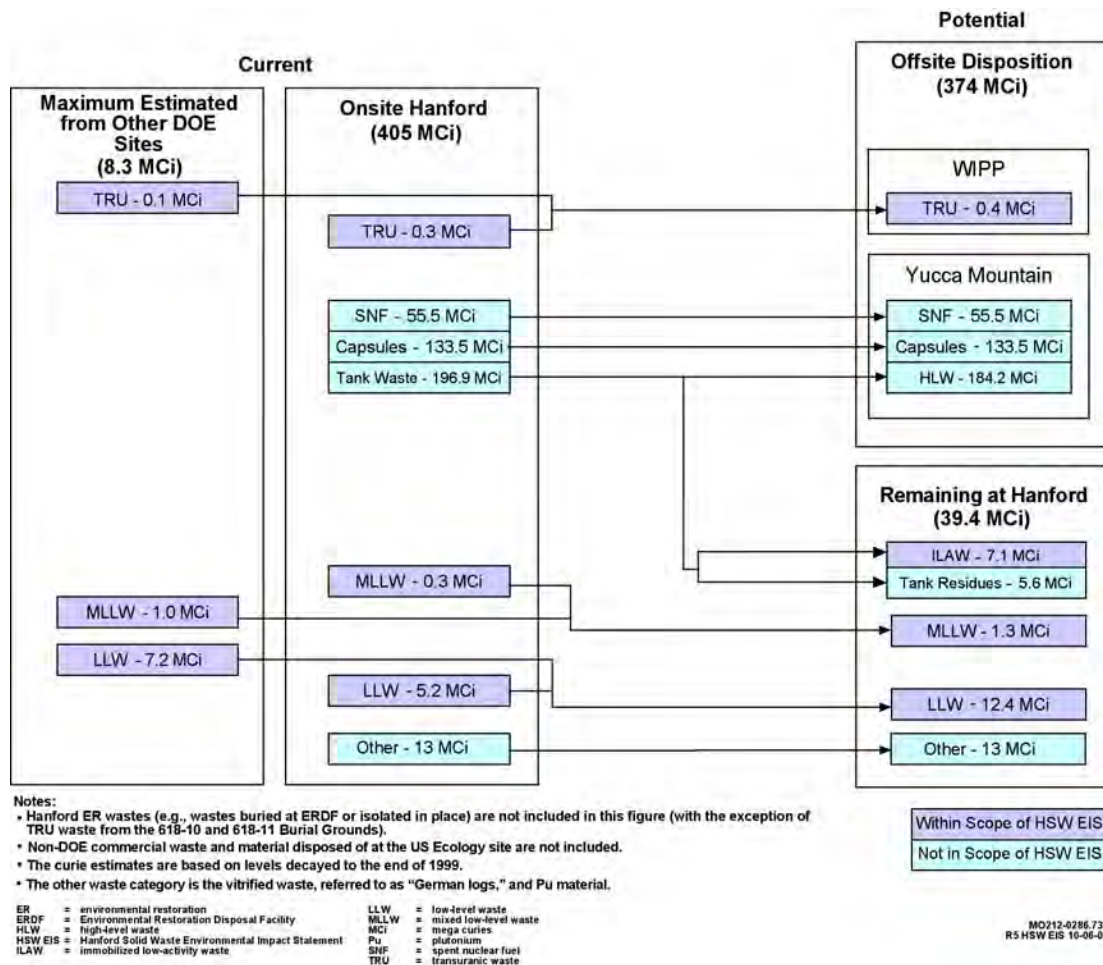
### **1.3.2.3 DOE Decisions Related to Waste Management at Hanford**

Several decisions have already been made that affect the management of various wastes and other nuclear materials at Hanford. Some of the decisions described in this section are being implemented, and other actions are scheduled to begin at a future time. The relationship between those activities and the alternatives for waste treatment, storage, and disposal as discussed in this HSW EIS is depicted in Figure 1.3. The NEPA and CERCLA reviews that resulted in the decisions illustrated in the figure are also listed. The relationship of the HSW EIS to other documents is further discussed in Section 1.5.

- HLW in Hanford storage tanks will be retrieved and vitrified at an onsite facility. DOE plans to dispose of HLW in a geologic repository at Yucca Mountain in Nevada (DOE 2002d). The TWRS EIS ROD (62 FR 8693) calls for ILAW to be placed in concrete vaults on the Hanford Site.
- Spent nuclear fuel stored in the Hanford K Basins near the Columbia River will continue to be dried and moved to the 200 East Area until it can be sent to the Yucca Mountain repository. A small quantity of other reactor fuel currently stored at Hanford will also be stored in the 200 East Area until it can be disposed of at Yucca Mountain.
- The Hanford Site will manage TRU waste from onsite operations, such as stabilization of plutonium materials at former processing facilities, and from some other DOE sites that do not have capabilities to manage TRU waste (see Volume II, Appendix C, Table C.1). In addition, TRU waste will be retrieved from the 618-10 and 618-11 Burial Grounds near the Energy Northwest Complex, and retrievably stored TRU waste will be retrieved from the 200 Area LLBGs. TRU waste will be treated as necessary and certified for disposal at WIPP near Carlsbad, New Mexico.
- LLW and MLLW from Hanford and other DOE sites will continue to be stored, treated, and/or disposed of at Hanford.

- Reactor compartments from decommissioned naval vessels will continue to be disposed of in a dedicated facility at Hanford.
- Contaminated areas along the Columbia River will continue to be cleaned up, especially sites near closed reactors in the 100 Areas and near fuel fabrication facilities in the 300 Area. Closed reactors will be placed into interim safe storage (a process referred to as “cocooning”) to protect people and the environment from the reactor cores until they can be safely removed. The 200 Area non-tank farm investigation activities are scheduled to be completed by December 31, 2008, pursuant to Milestone M-15-00C of the TPA. Most LLW and MLLW generated during Hanford environmental restoration projects will be sent to a dedicated onsite disposal facility, the Environmental Restoration Disposal Facility (ERDF).

The activities described in this section will result in most of the radioactive materials at Hanford being relocated to offsite facilities for disposal or other disposition. Figure 1.4 shows DOE’s radioactive material disposition plans at Hanford based on their radioactive material content.



**Figure 1.4.** Radioactive Material Disposition at Hanford in Terms of Waste Activity (MCi)

#### **1.3.2.4 Recent Regulatory Agreements**

On October 24, 2003, the United States and the State of Washington executed a settlement agreement (United States of America and Ecology 2003) resolving certain disagreements between the State of Washington and the United States with regard to changes to TPA milestones related to transuranic waste and mixed low-level waste. This settlement agreement also resolved a related administrative order issued by the Washington State Department of Ecology on April 30, 2003 (Ecology 2003) with regard to storage and treatment of mixed transuranic waste.

As a result of the settlement agreement, the sequence for retrieval of retrievably stored transuranic waste from the Low Level Burial Grounds may change from the sequence anticipated in DOE's previous plans as described in DOE (1987, 2002c). In addition, DOE will, as part of these retrieval activities, characterize for purposes of RCRA (42 USC 6901) and state dangerous waste regulations (WAC 173-303) the waste retrieved from these LLBGs. The MLLW would be appropriately treated, stored, and/or disposed of in compliant facilities. It is anticipated that the vast majority of MLLW would constitute debris waste under RCRA, for which the required treatment is macroencapsulation. A small component of the MLLW may require treatment by other methods (see Section 2.1.2). The specific quantities of retrievably stored suspect transuranic waste in the LLBGs that may need such treatment would not be known until retrieval operations are conducted. The retrieval would take place in the manner set forth in DOE (1987, 2002c). The worker and environmental consequences of retrieval activities are expected to be consistent with those described in the previously published documents (as summarized in Section 1.5.2). As a result of these actions, DOE expects the long-term environmental impacts of Hanford solid waste disposal could be slightly less than the impacts set forth in this HSW EIS because, for purposes of performing a conservative analysis, it was assumed that this MLLW would remain untreated and in an unlined facility. DOE would monitor these retrieval activities to determine whether additional environmental reviews are appropriate.

### **1.4 Related Department of Energy Initiatives at the Hanford Site**

Recent DOE management initiatives have provided a framework for alternatives being evaluated in this EIS. These initiatives are summarized in the following sections; additional information is provided in Volume II, Appendix N.

#### **1.4.1 EM Top-to-Bottom Review**

In 2001, DOE reviewed its efforts to clean up 114 sites nationwide that are managed as part of DOE's Environmental Management Program (DOE 2002a). Cleanup of 74 of those sites is complete, and cleanup efforts at other sites are well under way. However, costs and schedules for the more extensive cleanup efforts, including Hanford, were expected to increase unless there were major changes in the way cleanup work was being managed. That review, referred to as the Top-to-Bottom Review, was intended to identify problems and recommend improvements to accelerate cleanup, reduce risks, and reduce costs.

The review concluded that DOE's emphasis was on managing risks to people and the environment rather than reducing those risks. The review identified 12 issues and related recommendations, some of



which could change current plans for managing waste at Hanford if they are implemented. Some of the recommendations made in the Top-to-Bottom Review could be implemented immediately. Some, including the possible changes to waste management activities at Hanford, would require additional planning. Prior to implementation of any of the recommendations, appropriate environmental documentation would be prepared.

#### **1.4.2 DOE Cost Report**

In 2002, DOE prepared a life-cycle cost analysis addressing the disposal of DOE's low-level waste (DOE 2002e). Life-cycle disposal costs include those related to transportation, disposal, closure, and long-term stewardship. The report discussed facilities for the disposal of LLW from cleanup actions under CERCLA (e.g., the Environmental Restoration Disposal Facility) as well as facilities used for other LLW disposal (e.g., the LLBGs). The report was prepared to address congressional concerns regarding the cost of LLW disposal, the extent to which DOE fee structures reflect actual life-cycle costs, and the impact of DOE disposal facilities on commercial LLW disposal.

The report concluded that pre-disposal costs, such as packaging and transportation, offer the greatest opportunity for cost savings. DOE disposal facilities established for CERCLA cleanup actions typically had the lowest life-cycle disposal costs per unit of waste because of the nature of wastes disposed of at those facilities. Commercial facilities may be more cost-effective for some types of waste; however, DOE facilities provide services that are not available at commercial facilities. In general, the report recommended that DOE consider all elements of life-cycle costs, in addition to disposal fees, in making decisions regarding LLW disposal.

#### **1.4.3 Cleanup, Constraints, and Challenges Team (C3T)**

In 2001, the DOE Richland Operations Office (DOE-RL), its contractors, EPA, and Ecology began a series of discussions to better identify, characterize, and resolve constraints and barriers to Hanford cleanup. Tribal nations were also invited to participate in these discussions. These discussions, referred to as the Cleanup, Constraints, and Challenges Team (C3T) process, are designed to be an informal forum where ideas and concepts could be discussed openly (DOE-RL 2002a). Ideas are developed and evaluated to determine whether they could accelerate cleanup; reduce costs; or protect workers, the public, and the environment. The C3T process is not intended to replace legal or regulatory requirements, or to change formal commitments such as the TPA. Some concepts identified during the C3T process might be suitable for immediate implementation. However, most would probably require further planning, changes to existing permits and TPA Milestones, changes to existing contracts, and preparation of additional NEPA or CERCLA reviews. Additional information can be found in Volume II, Appendix N.

#### **1.4.4 Hanford Performance Management Plan (HPMP)**

Drawing on recommendations contained in the Top-to-Bottom Review and on ideas emerging from the C3T process (DOE-RL 2002a), a plan was prepared to accelerate cleanup at Hanford (DOE-RL 2002b). The plan describes higher-level strategic initiatives as well as specific goals for completing Hanford cleanup by 2035, which is 35 years earlier than previously planned.

Some of the acceleration activities described in the HPMP could be implemented immediately. Others could be implemented as a result of reviews performed under this HSW EIS. Some, however, would require further planning, changes to existing permits and TPA milestones, and preparation of additional NEPA or CERCLA reviews. Implementation of some of the accelerated cleanup proposals is discussed in Section 3. However, the plans and schedules associated with many HPMP proposals were not sufficiently well developed for detailed analysis at the time this EIS was prepared. Therefore, the analyses of environmental impacts presented in Section 5 do not necessarily reflect all activities, or the timing of some activities, as described in the HPMP. Additional information can be found in Volume II, Appendix N.

## **1.5 Relationship of the HSW EIS to Other Hanford and DOE NEPA Documents**

A number of other DOE programmatic and Hanford actions are related to this HSW EIS. The relationships of these actions and associated NEPA documents to the HSW EIS are described in the following sections and were illustrated previously in Figure 1.2.

### **1.5.1 Interim Actions During Preparation of the HSW EIS**

During the preparation of the HSW EIS, DOE determined that several actions within or related to the scope of the EIS met the criteria for permissible interim actions under 40 CFR 1506.1. These actions are described in the following documents:

- **Offsite Thermal Treatment of Low-Level Mixed Waste (DOE/EA-1135 May 1999)**

This Environmental Assessment (EA) analyzed the use of Allied Technology Group, Inc. (ATG), a commercial treatment facility in Richland, Washington, to thermally treat a portion of MLLW stored at the Hanford Site (DOE 1999a). DOE considered the use of ATG for treatment of a limited quantity of MLLW from Hanford as a demonstration project. This EA analyzed impacts of transporting the MLLW from Hanford to ATG, treatment of the waste in the ATG facility, and transportation of the treated waste back to Hanford for disposal. Construction and operation of the ATG treatment facility was evaluated in a State Environmental Policy Act (SEPA) EIS (City of Richland 1998). Based on analyses in the EA, DOE determined the proposed action was not a major federal action significantly affecting the quality of the human environment and issued a finding of no significant impact (FONSI) on May 6, 1999.

- **Non-Thermal Treatment of Hanford Site Low-Level Mixed Waste (DOE/EA-1189 September 1998)**

This EA considered the use of the ATG commercial treatment facility to stabilize or encapsulate a portion of Hanford MLLW to allow disposal of the waste (DOE 1998). Regulatory requirements for treatment of MLLW to allow land disposal vary depending upon the nature of the waste. Wastes considered in this EA consisted of those that did not require thermal treatment. The ATG facility was

also considered for thermal treatment of a portion of the Hanford MLLW (DOE 1999a). Construction and operation of the ATG treatment facility was evaluated in a SEPA EIS (City of Richland 1998). Based on analyses in the EA, DOE determined the proposed action was not a major federal action significantly affecting the quality of the human environment and issued a FONSI on September 29, 1998.

- **Widening Trench 36 of the 218-E-12B Low-Level Burial Ground (DOE/EA-1276 February 1999)**

This EA was prepared to assess potential environmental impacts associated with the proposed action to widen and operate the existing and unused Trench 36 in the 218-E-12B LLBG for disposal of bulk LLW (DOE 1999b). The existing V-type LLW trenches were designed before 1976 and were analyzed in a previous Environmental Statement (ERDA 1975). DOE determined the trench design was inefficient for disposal of bulk waste. The V-type trenches are narrow at the bottom and are generally less than about 5 m (16 ft) deep. DOE determined that widening the trenches would more efficiently use LLBG space. Given trenches of equivalent depth, the wider trenches allow more waste to be placed per square foot of surface area. This pattern not only saves trench construction costs but also decreases closure cover size and cost for disposal of a given volume of waste. Based on analyses in the EA, DOE determined the proposed action was not a major federal action significantly affecting the quality of the human environment and issued a FONSI on February 11, 1999.

- **K Basins Sludge Storage at 221-T Building, Hanford Site, Richland, Washington (DOE/EA-1369 June 2001)**

This EA was prepared to assess potential environmental impacts associated with modification of the 221-T Building (part of the T Plant Complex) to receive and store sludge from the 100-K Area fuel storage basins at the Hanford Site (DOE 2001b). The proposed action included modification of the pool cell and other shielded cells within the facility to store the sludge. The sludge would ultimately be designated as RH TRU waste and transferred to the Hanford Solid Waste Program for storage, processing at an onsite facility, and shipment to WIPP for disposal. Based on analyses in the EA, DOE determined the proposed action was not a major federal action significantly affecting the quality of the human environment and issued a FONSI on June 20, 2001.

- **(Draft) Environmental Assessment for Trench Construction and Operation in the 218-E-12B and 218-W-5 Low Level Burial Grounds, Hanford Site, Richland, Washington (DOE/EA-1373 February 2001)**

This draft EA was prepared to assess potential environmental impacts associated with the proposed action to construct four new LLW disposal trenches in the Hanford Site 200 East and 200 West Areas (DOE 2001a). Additional trench capacity was determined to be necessary over the short-term for operational efficiency in disposing of different physical types of LLW at Hanford. The EA has not been finalized.

## 1.5.2 Related NEPA Documents

Solid waste management operations at Hanford have been assessed previously in a number of documents. This section briefly describes other NEPA documents related to the HSW EIS. They offer background material for understanding the HSW EIS and its purpose.

- **Final Environmental Statement, Waste Management Operations, Hanford Reservation, Richland, Washington (ERDA-1538 December 1975)**

The U.S. Energy Research and Development Administration (ERDA) prepared an Environmental Statement for use in planning and decision making to ensure that future waste management practices would minimize adverse environmental consequences (ERDA 1975). Treatment and disposal of waste from onsite and offsite sources were addressed. This document was written for the Waste Management Operations Program at the Hanford Site. Because this document predated the CEQ NEPA regulations, a formal ROD was not issued. The HSW EIS provides an updated analysis and revisits potential alternatives for some aspects of Hanford Solid Waste Program operations.

- **Disposal of Decommissioned Defueled Naval Submarine Reactor Plants EIS (U.S. Department of the Navy 1984)**

This EIS considered the disposal of defueled naval submarine reactor compartments in the Hanford LLBGs (Navy 1984). The EIS was prepared by the U.S. Department of the Navy and was adopted by DOE. The EIS analyzed preparation of the reactor compartments at the Puget Sound Naval Shipyard, transportation to Hanford, and disposal in the 200 Areas. The ROD was published in the *Federal Register* on December 6, 1984 (49 FR 47649).

- **Disposal of Hanford Defense High-Level, Transuranic and Tank Wastes, Hanford Site, Richland, Washington (DOE/EIS-0113 December 1987)**

In 1987, DOE prepared the Hanford Defense Waste (HDW) EIS to examine potential impacts storing and preparing TRU waste and tank waste, as well as future wastes, for disposal (DOE 1987). Most LLW and wastes associated with decommissioning of existing surplus or retired Hanford Site facilities were not considered in the HDW EIS. In the 1988 ROD (53 FR 12449), DOE decided to dispose of or store double-shell tank waste and cesium and strontium capsules. Retrievably stored TRU waste in the 200 Area LLBGs would be retrieved and disposed of with other newly generated TRU waste. A decision was also made to retrieve buried suspect TRU-contaminated waste from the 618-11 Burial Ground. As part of that decision, DOE decided to construct and operate a facility for vitrification of HLW, facilities for grout stabilization and disposal of the low-activity fraction from processing tank waste, and the Waste Receiving and Processing (WRAP) facility for processing, certification, and shipment of TRU waste. Subsequent to preparation of the HDW EIS, the TPA was established to implement many of the actions discussed in the ROD. The agreement also ensures compliance with applicable RCRA, CERCLA, and State of Washington requirements.

This HSW EIS provides an updated analysis for some Hanford Solid Waste Program operations previously evaluated in the HDW EIS, such as processing and certification of TRU waste and disposal of ILAW. For some other activities evaluated in the HDW EIS, such as retrieval and processing of Hanford tank waste, additional NEPA review has either been prepared or may be prepared required in the future. For example, the TWRS EIS updated some aspects of retrieval, processing, and disposal of Hanford tank waste (DOE and Ecology 1996). In addition, the EIS for retrieval, treatment, and disposal of Hanford tank waste and for closure of 149 single-shell tanks (68 FR 1052) would provide further updates of some activities addressed in the HDW EIS, the TWRS EIS, and this HSW EIS.

The HSW EIS assumes complete retrieval of TRU waste stored in the LLBGs and caissons based on the HDW EIS ROD. The consequences from the HDW EIS alternative for retrieving and processing both retrievably stored and newly generated TRU waste for disposal at a geologic repository are summarized in Table 1.1. An initial project to retrieve about 20 percent of the TRU waste volume stored in the LLBGs has been evaluated in a recent EA (DOE 2002c). Retrieval of the remaining TRU waste would be based on experience gained during the initial project, with additional NEPA review as appropriate. Processing, certification, and transportation of TRU waste to WIPP are evaluated in Section 5 of this HSW EIS.

**Table 1.1.** Consequences of Retrieving and Processing TRU Waste as Evaluated in the HDW EIS

Activity	Geologic Disposal Alternative
<b>Routine Operations</b>	
Occupational Radiation Dose (person-rem)	140
Radiation Dose to Maximally Exposed Offsite Individual over 70 years (rem)	1E-4
Radiation Dose to Offsite Population over 70 years (person-rem)	9
<b>Facility Accidents</b>	
Radiation Dose to Maximally Exposed Offsite Individual (rem)	5E-2
Collective Radiation Dose to Offsite Population (person-rem)	100
<b>Non-Radiological Impacts</b>	
Occupational Illness & Injury (number of recordable events)	520
Occupational Fatality (number of events)	2

- **Environmental Assessment for Battelle Columbus Laboratories Decommissioning Project (DOE/EA-0433 June 1990)**

This EA evaluated decommissioning of radiological laboratories operated by Battelle Memorial Institute (DOE 1990). Waste, including TRU waste, generated during the cleanup of 15 buildings at two sites would be shipped to Hanford. The TRU waste would be stored until it could be accepted at WIPP. DOE determined the proposed action was not a major federal action significantly affecting the quality of the human environment and issued a FONSI on June 14, 1990.

- **Environmental Assessment – Hanford Environmental Compliance Project, Hanford Site, Richland Washington (DOE/EA-0383 March 1992)**

This EA included an evaluation for construction and operation of the ETF in the Hanford Site 200 East Area (DOE 1992). This facility would receive leachate collected from the MLLW trenches, in addition to other liquid waste generated at Hanford. The EA also evaluated construction of additional storage buildings at the Central Waste Complex (CWC). Based on analyses in the EA, DOE determined the proposed action was not a major federal action significantly affecting the quality of the human environment and issued a FONSI on March 11, 1992.

- **Solid Waste Retrieval Complex, Enhanced Radioactive and Mixed Waste Storage Facility, Infrastructure Upgrades, and Central Waste Complex (DOE/EA-0981 September 1995)**

In this EA, DOE proposed to construct and operate the Solid Waste Retrieval Complex and the Enhanced Radioactive Mixed Waste Storage Facility, to expand the CWC, and to upgrade the associated Hanford infrastructure (DOE 1995b). These facilities were to be located in the 200 West Area to support the Solid Waste Operations Complex (SWOC) operation. The proposed action was to address retrieval of TRU waste, storage capacity for retrieved and newly generated TRU waste, and upgrading the infrastructure network in the 200 West Area to enhance operational efficiencies and reduce the cost of operating the existing SWOC. Actions evaluated in the EA included

- construction and operation of the Retrieval Complex and the Enhanced Radioactive Mixed Waste Storage Facility
- expansion of the CWC
- upgrading associated infrastructure (that is, utilities and roads) in the 200 West Area to support the SWOC
- retrieval of TRU waste in the solid waste LLBGs and the construction, operation, and maintenance of a complex of facilities to be used for the retrieval
- construction of a regulatory-compliant storage facility for greater than Category 3 (GTC3) waste, retrieved TRU waste and newly generated TRU waste awaiting processing in the WRAP, and for processed waste awaiting shipment to WIPP

- construction of two pre-engineered metal solid waste management support buildings.

In addition, the proposed action included a mitigation strategy to address lost shrub-steppe habitat. Based on analyses in the EA, DOE determined the proposed action was not a major federal action significantly affecting the quality of the human environment and issued a FONSI on September 8, 1995. This HSW EIS considers post-retrieval processing, certification, and shipment to WIPP for retrievably stored TRU waste in the LLBGs.

- **Environmental Assessment. Shutdown of the Fast Flux Test Facility. Hanford Site, Richland, Washington (DOE/EA-0993 May 1995)**

This EA was prepared to assess environmental impacts from shutdown of the Fast Flux Test Facility, a liquid-metal cooled research reactor located in the Hanford Site 400 Area (DOE 1995a). Deactivation would consist of removing fuel, draining and de-energizing the systems, removing the stored radioactive and hazardous materials, and performing other actions to place the facility in a safe shutdown state. Deactivation of this facility could generate LLW, MLLW, or TRU waste that would be processed or disposed of in facilities considered under the HSW EIS. Based on analyses in the EA, DOE determined the proposed action was not a major federal action significantly affecting the quality of the human environment and issued a FONSI on May 1, 1995.

- **Management of Spent Nuclear Fuel from the K Basins at the Hanford Site, Richland, Washington (DOE/EIS-0245 January 1996)**

This EIS evaluated alternatives for treatment and interim storage of irradiated fuels from the Hanford production reactors (DOE 1996b). After the reprocessing of production reactor fuels for weapons material at Hanford was suspended, a substantial quantity of unprocessed irradiated fuel remained in the fuel storage basins at the 100-K Area. As a result of the EIS analysis, DOE decided to stabilize the stored fuel using a cold vacuum drying process, package the fuel into storage canisters, and place the canisters into storage in the 200 East Area at Hanford. The EIS also addressed cleaning out the 100-K Area fuel storage basins following removal of the fuel. The EIS evaluated storage of the retrieved sludge in underground tanks for eventual treatment with other Hanford tank wastes, or alternatively, grouting the sludge fractions that could be disposed of at Hanford. A ROD was issued in the *Federal Register* on March 15, 1996 (61 FR 10736). The HSW EIS evaluates storage and treatment of the sludge by the Hanford Solid Waste Program, an alternative not considered in the K Basin EIS. The treated sludge would ultimately be disposed of at WIPP with other Hanford TRU waste.

- **Plutonium Finishing Plant Stabilization Final Environmental Impact Statement (DOE/EIS-0244-F May 1996)**

The Plutonium Finishing Plant (PFP) in the Hanford Site 200 West Area was constructed to process plutonium nitrate into the metallic form used in nuclear weapons. The PFP includes production and

recovery areas, laboratories for routine analysis and research, and secure vaults for storage of plutonium. PFP ceased operations in 1989. DOE prepared the PFP EIS (DOE 1996c) to evaluate consequences from

- stabilization of plutonium-bearing materials at the PFP to a form suitable for interim storage
- removal of readily retrievable, plutonium-bearing materials left behind in process equipment, process areas, and air and liquid waste management systems as a result of historic uses
- placement of stabilized fissile material in existing vaults at the PFP for interim storage.

The alternatives for stabilization included processing the plutonium-bearing materials into a form suitable for interim storage in existing PFP vaults. The EIS also evaluated options for removing and stabilizing plutonium-bearing wastes and material in holdup at the PFP. A ROD was issued in the *Federal Register* on June 25, 1996 (61 FR 36352). Stabilization of the PFP materials and deactivation of the facility have been, and will continue to be, major sources of TRU waste managed by the Hanford Solid Waste Program.

- **Disposal of Decommissioned, Defueled Cruiser, Ohio Class, and Los Angeles Class Naval Reactor Plants (DOE/EIS-0259 April 1996)**

This EIS considered the disposal of certain defueled Naval Reactor plants in a Hanford LLBG. The EIS was prepared by the U.S. Department of the Navy (1996). The EIS analyzed preparation of the reactor compartments at the Puget Sound Naval Shipyard, transportation to Hanford, and disposal in the 218-E-12B Burial Ground in the Hanford 200 East Area. DOE participated as a cooperating agency in the development of the EIS on this federal action and has adopted the EIS. The ROD was issued in the *Federal Register* on August 9, 1996 (61 FR 41596).

- **Tank Waste Remediation System EIS (DOE/EIS-0189 August 1996)**

In the TWRS EIS, DOE examined the management and disposal of the contents of 177 tanks in the HLW tank farms, as well as cesium and strontium capsules (DOE and Ecology 1996). In the ROD, DOE decided to retrieve, separate, vitrify, and dispose of the tank waste (62 FR 8693). The low-activity waste fraction from the separation process would be placed in concrete vaults onsite. The HLW would be disposed of at a repository. A decision on the disposition of cesium and strontium capsules was deferred. Programs for retrieval and treatment of the tank waste are expected to be major generators of LLW and MLLW sent to the Hanford Solid Waste Program for disposal in Hanford LLBGs. Disposal of ILAW, melters, and operational waste from the tank waste treatment plant are considered in the waste streams evaluated for this HSW EIS.



- **Supplemental Environmental Impact Statement for Disposal of Immobilized Low-Activity Wastes from Hanford Tank Waste Processing (DOE/EIS-0189-S1)**

As part of the TWRS EIS decision, DOE planned to place ILAW into concrete vaults in the 200 East Area. DOE began examining alternatives for disposing of ILAW onsite in near-surface facilities. Following a supplement analysis of disposal options for ILAW (DOE 2001g), DOE decided additional NEPA review was required, and a Notice of Intent to prepare a Supplemental Environmental Impact Statement (SEIS) was issued on July 8, 2002 (67 FR 45104). Subsequently, based on public comments received, DOE decided to combine the ILAW disposal SEIS with this HSW EIS. The HSW EIS now provides a NEPA review for ILAW disposal in addition to waste management operations conducted by the Hanford Solid Waste Program (68 FR 7110).

- **Environmental Impact Statement for Retrieval, Treatment, and Disposal of Tank Waste and Closure of Single-Shell Tanks at the Hanford Site, Richland, Washington (DOE/EIS-0356)**

DOE recently announced its intent to prepare a follow-on EIS to the TWRS EIS for retrieval, treatment, and disposal of Hanford tank waste, and for closure of 149 single-shell tanks (68 FR 1052). That EIS would evaluate alternative treatment processes for some tank waste and disposal of low-activity waste forms other than those considered in this HSW EIS. The HSW EIS evaluates disposal of secondary LLW and MLLW generated during retrieval and treatment of Hanford tank waste based on current waste forecasts. If those waste forecasts change substantially as a result of potential new tank waste treatment technologies or modified design for the WTP, additional evaluation of LLW and MLLW disposal impacts may be provided as part of the proposed Tank Closure EIS (68 FR 1052) or other appropriate NEPA review.

- **Waste Management Programmatic EIS (DOE/EIS-0200 May 1997)**

The WM PEIS is a DOE nationwide study examining the environmental impacts of managing more than 2,000,000 m<sup>3</sup> (2,700,000 yd<sup>3</sup>) of radioactive wastes from past, present, and future DOE activities (DOE 1997c). The DOE goal in preparing the WM PEIS was to develop a national strategy to treat, store, and dispose of the wastes in a safe, responsible, and efficient manner that minimizes the impacts to workers, the public and the environment. DOE used the analyses in the WM PEIS to decide on a programmatic approach to managing its waste, and to select a configuration of DOE sites for waste management activities based on those analyses and other factors.

The level of analysis in the WM PEIS was judged appropriate for making broad programmatic decisions on which DOE sites should be selected for waste management missions. However, at the programmatic level, it was not possible to take into account special requirements for particular waste streams, different technologies that are, or may be, available to manage specific wastes, or site-specific environmental considerations such as the presence of culturally important resources or endangered species at a given location on a site. DOE is relying on other NEPA reviews for those analyses, primarily ones that evaluate particular locations or projects. Decisions regarding specific

locations for waste management facilities at DOE sites, the waste management technologies to be used, and potential mitigation measures will be made on the basis of existing or new sitewide or project-level NEPA reviews.

Wastes analyzed in the WM PEIS result primarily from nuclear weapons production and related activities. They include MLLW, LLW, TRU waste, HLW, and hazardous waste. The WM PEIS provides information on the impacts of various alternatives that DOE evaluated to decide at which sites to consolidate or decentralize treatment, storage, and disposal activities for each waste type. The WM PEIS evaluated a total of 36 alternatives for the 5 waste types. The alternatives represented different configurations for managing each waste type at varying numbers of DOE facilities. The alternatives were described as decentralized, regionalized, or centralized, depending on the degree to which waste management activities were consolidated or distributed across the DOE waste generator sites. A no action alternative was also evaluated, in which only existing waste management capabilities would be used.

In the decentralized alternatives, each site that generates waste would manage the waste onsite. Unlike the no action alternative, the decentralized alternatives would involve construction of new waste management facilities at a larger number of sites than in the other alternatives (5-37 sites, depending on the waste type and activity). At least two regionalized alternatives were evaluated for each waste type, where waste management activities would be consolidated at a smaller number of sites than in the decentralized alternatives, but at a greater number of sites than in the centralized alternatives (1-12 sites, depending on the waste type and activity). The sites identified as regionalized waste management sites for a given waste type were expected to generate relatively large quantities of that waste, and they generally had existing waste management facilities and capabilities. The centralized alternatives evaluated consolidated management of each waste type at the smallest number of sites (1-7 sites, depending on the waste type and activity), again representing sites that were expected to generate the largest quantities of a particular waste.

Management of CERCLA waste generated by DOE environmental restoration activities was reviewed, but not comprehensively analyzed, in the WM PEIS. However, waste from decommissioning and closure of some smaller DOE sites was considered as part of the total waste volumes to be managed within the DOE complex. The Natural Resources Defense Council and other non-governmental groups filed a lawsuit in 1997 to require DOE to prepare a programmatic EIS for its environmental restoration program. The lawsuit was settled in 1998 when DOE and the other parties agreed to develop tools that would enhance public understanding of DOE site cleanup. Under the terms of the settlement, no changes were made to the WM PEIS. DOE agreed to complete the following items:

1. Develop and deploy a Central Internet Database with information on waste, materials, facilities, and contaminated media (see: <http://cid.em.doe.gov/>).
2. Conduct a study on long-term stewardship (DOE 2001e).

3. Establish a \$6.25 million fund for technical and scientific reviews by citizen and tribal organizations.

The draft WM PEIS was issued in September 1995, followed by a 150-day public comment period. The Final WM PEIS was issued in May 1997, and the initial decisions for each waste type analyzed in the WM PEIS were issued between January 1998 and February 2000. Several amendments to the original decisions were subsequently issued to address specific waste management needs that were not included in the initial RODs. Major decisions resulting from the WM PEIS are summarized by waste type as follows:

- **TRU Waste.** DOE decided that, with one exception, TRU waste at DOE sites would be treated and stored at the generator sites prior to disposal at WIPP (63 FR 3629). The decision was later revised to transfer small quantities of TRU waste to other sites that have existing storage and treatment capabilities (65 FR 82985, 66 FR 38646, 67 FR 56989). In one of those revisions (67 FR 56989), DOE decided that about 36 m<sup>3</sup> (1300 ft<sup>3</sup>) of TRU waste from facilities in Ohio and California would be transferred to Hanford for storage and processing before being shipped to WIPP.
- **Low-Level Waste and Mixed Low-Level Waste.** Under this decision, DOE will continue to rely on sites that have existing capacity to treat or dispose of LLW and MLLW (65 FR 10061). Hanford and the Nevada Test Site (NTS) were identified in the ROD to receive LLW and MLLW from other DOE sites that do not have capabilities to dispose of their wastes. The INEEL, Los Alamos National Laboratory, the ORR and the SRS would continue to dispose of LLW generated at those sites. DOE also identified Hanford, the INEEL, ORR, and SRS as regional MLLW treatment facilities that could accept waste from other sites for treatment. Those decisions generally represent a continuation of ongoing treatment and disposal activities at the identified sites and do not affect DOE's ability to send waste to commercial treatment or disposal facilities.
- **Non-Wastewater Hazardous Waste.** The hazardous waste treatment ROD (63 FR 41810) announced a DOE decision to continue to use commercial facilities for the treatment and disposal of non-wastewater hazardous waste generated at DOE sites.
- **High-Level Waste.** The HLW storage ROD determined that HLW should be stored at the generator sites pending disposal in a geologic repository (64 FR 46661).

This HSW EIS evaluates the Hanford site-specific impacts of proposed waste management operations and activities at the project level, consistent with the WM PEIS. The WM PEIS evaluated Hanford as a receiving site for both regionalized and centralized alternatives within each waste type. Therefore, the analyses for waste coming to Hanford encompassed a range of waste volumes that represented largely Hanford-generated waste in the decentralized alternatives, to larger quantities in the centralized alternatives that represented a substantial fraction of a particular waste type to be generated at DOE sites across the nation. For LLW, the waste volumes ranged from 89,000 m<sup>3</sup> generated at Hanford to 1,500,000 m<sup>3</sup> generated at Hanford as well as at other DOE sites. The corresponding

MLLW volumes were 36,000 m<sup>3</sup> for Hanford to 219,000 m<sup>3</sup> including waste from other DOE sites. The range for TRU waste was 52,000 m<sup>3</sup> from Hanford to 132,000 m<sup>3</sup> including waste from other DOE sites.

The range of waste volumes evaluated in the WM PEIS therefore encompasses the range of waste volumes considered in this HSW EIS for LLW, MLLW, and TRU waste (see Section 3.3 and Volume II, Appendixes B and C). Likewise, the environmental consequences of transporting and managing waste from other DOE sites at Hanford are expected to be similar to the impacts presented in the WM PEIS. The site-specific consequences of waste management alternatives considered in this HSW EIS are presented in Section 5 (Volume I) and the associated appendixes (Volume II). Potential mitigation measures that might be required as a result of implementing the alternatives are discussed in Section 5.18.

- **Relocation and Storage of Isotopic Heat Sources (DOE/EA-1211 June 1997)**

In this EA, DOE proposed construction and operation of a storage site at the CWC in the 200 West Area of the Hanford Site for storage, pending future disposal decisions, of isotopic heat sources that were previously stored in the 324 Building (DOE 1997a). The material includes 34 isotopic sources: 30 sealed isotopic heat sources manufactured in the 324 Building as part of a bilateral agreement between the Federal Republic of Germany and DOE; two production demonstration canisters; and two instrumented canisters. The agreement was for developing processes for the treatment and immobilization of HLW. Subsequently, the need for the sources was eliminated and Germany and DOE entered into another agreement for the storage and disposition of the materials. Based on analyses in the EA, DOE determined the proposed action was not a major federal action significantly affecting the quality of the human environment and issued a FONSI on June 6, 1997.

- **Trench 33 Widening in 218-W-5 Low Level Burial Ground (DOE/EA-1203 July 1997)**

In this EA, DOE proposed to widen and operate the existing and unused disposal Trench 33 within the 218-W-5 LLBG in the 200 West Area for disposal of LLW (DOE 1997b). The existing V-type LLW trenches were designed before 1976 and were analyzed in a previous Environmental Statement (ERDA 1975). The widening of Trench 33 increased the disposal capacity and allowed for disposal of both boxed and large packages of Category (Cat) 1 LLW that would not efficiently fit in the existing V-type trench configuration. The proposed action provided for more cost-effective land use and increased the capacity of the LLBG without increasing the footprint. Based on analyses in the EA, DOE determined the proposed action was not a major federal action significantly affecting the quality of the human environment and issued a FONSI on July 28, 1997.

- **Waste Isolation Pilot Plant Disposal Phase Final Supplemental EIS (DOE/EIS-0026-S-2 September 1997)**

- DOE prepared the *Waste Isolation Pilot Plant Disposal Phase Final Supplemental EIS* (WIPP SEIS-II) to consider disposal of TRU waste at the WIPP (DOE 1997d). The supplement evaluated transportation methods, the disposal inventory, and the level of treatment required for

disposal or storage (repackaging to meet planning basis WIPP waste acceptance criteria, thermal treatment, or treatment by shred and grout). The Hanford Site was considered for treatment of TRU waste by any of the three methods, and for storage of TRU waste (either without disposal at WIPP or pending disposal). The ROD was issued on January 23, 1998, to dispose of Hanford and other sites' TRU waste at WIPP (63 FR 3623), after treatment to meet WIPP waste acceptance criteria. The HSW EIS provides an updated site-specific analysis of impacts from processing Hanford's TRU waste prior to its ultimate disposal at WIPP.

- **Final Hanford Comprehensive Land-Use Plan EIS (DOE/EIS-0222F September 1999)**

DOE prepared a *Final Hanford Comprehensive Land-Use Plan EIS* (HCP EIS, formerly named *Hanford Remedial Action Environmental Impact Statement and Comprehensive Land-Use Plan*) to evaluate the potential environmental impacts associated with implementing a comprehensive land-use plan for the Hanford Site for at least the next 50 years (DOE 1999c). Working with federal, state, and local agencies and tribal governments, DOE evaluated six land-use alternatives. In the ROD for the HCP EIS, DOE decided to designate the 200 Areas for Industrial-Exclusive use and Area C for Conservation-Mining (64 FR 61615). Radioactive and hazardous waste treatment, storage, and disposal activities, as described in this HSW EIS, are consistent with the Industrial-Exclusive land use selected for the 200 Areas and use of Area C as a borrow pit consistent with the Conservation-Mining land use selected for that area in the HCP EIS decision. (See Figure 4.2 in the HSW EIS for a land-use map.)

- **Environmental Assessment for the Offsite Transportation of Certain Low-level and Mixed Radioactive Waste from the Savannah River Site for Treatment and Disposal at Commercial and Government Facilities (DOE/EA-1308 February 2001)**

This EA was prepared to evaluate near-term offsite treatment and disposal options for LLW and MLLW because onsite treatment and disposal capabilities for these waste forms were not available at the Savannah River Site (DOE 2001d). These waste forms would comprise an estimated volume of approximately 136,057 m<sup>3</sup> (4,804,282 ft<sup>3</sup>). The EA considered transport by either truck or rail to seven potential treatment or disposal facilities, including the Hanford Site. Based on analyses in the EA, DOE determined the proposed action was not a major federal action significantly affecting the quality of the human environment and issued a FONSI.

- **Environmental Assessment for Transportation of Low-level Radioactive Waste from the Oak Ridge Reservation to Off-Site Treatment or Disposal Facilities (DOE/EA-1315)**

The EA evaluates the potential environmental impacts associated with transportation of legacy and operational LLW from the Oak Ridge Reservation in Tennessee for treatment or disposal at various locations in the United States (66 FR 64406). The proposed action was to package as needed, load, and ship existing (about 40,000 m<sup>3</sup> [1,410,000 ft<sup>3</sup>]) and forecasted (about 7700 m<sup>3</sup>/yr [271,000 ft<sup>3</sup>/yr]) LLW from ORR to existing or future facilities at other DOE sites, including Hanford, or to licensed commercial nuclear waste treatment or disposal facilities. Transport by truck, by rail, or by inter-modal carrier (i.e., truck and rail combination) was considered. Based on analyses in the EA, DOE

determined the proposed action was not a major federal action significantly affecting the quality of the human environment and issued a FONSI on October 29, 2001.

- **Environmental Assessment – Disposition of Surplus Hanford Site Uranium, Hanford Site, Richland, Washington (DOE/EA-1319 June 2000)**

An EA was prepared to assess environmental impacts associated with the disposition of surplus Hanford Site uranium (DOE 2000). DOE identified about 1865 metric tons of uranium (MTU) on the Hanford Site as surplus. Of that total, DOE decided to relocate approximately 900 MTU of potentially saleable uranium materials to DOE's Portsmouth site near Portsmouth, Ohio, for future beneficial use. The remaining materials consisted of approximately 140 MTU that were subsequently disposed of onsite, and approximately 825 MTU, which would be consolidated and stored in the 200 Areas pending final HSW EIS decisions. The materials designated for onsite management may ultimately be transferred to the Hanford Solid Waste Program for disposal in the Hanford Site LLBGs, and are included in the forecasts used to determine waste volumes in this EIS. Based on analyses in the EA, DOE determined the proposed action was not a major federal action significantly affecting the quality of the human environment and issued a FONSI on June 15, 2000.

- **Environmental Assessment – Use of Existing Borrow Areas, Hanford Site, Richland, Washington (DOE/EA-1403 October 2001)**

This EA evaluated potential environmental consequences of operating existing borrow areas at the Hanford Site to provide soil, sand, gravel, and rock for construction projects, site maintenance activities, and closure of solid waste burial sites (DOE 2001c). Although the total quantities of material necessary for final closure of the 200 Area LLBGs were not included in this EA, the locations evaluated included likely sources for these materials in the foreseeable future. Based on analyses in the EA, DOE determined the proposed action was not a major federal action significantly affecting the quality of the human environment and issued a FONSI on October 10, 2001.

- **Environmental Assessment – Transuranic Waste Retrieval from the 218-W-4B and 218-W-4C Low-Level Burial Grounds, Hanford Site, Richland, Washington (DOE/EA-1405 March 2002)**

This EA was prepared to evaluate alternatives for retrieval of about 20 percent of the suspect TRU waste volume that was retrievably stored in the LLBG trenches (DOE 2002c). The analysis updates some aspects of evaluations for TRU waste retrieval previously published in the HDW EIS (DOE 1987) and a subsequent EA (DOE 1995b). The activity would involve recovery of up to 15,200 208-L (55-gal) drums and a small number of miscellaneous other containers of suspect TRU waste buried in the 200 West Area LLBGs. The contents of each container would be evaluated and containers determined not to be TRU waste would remain in the LLBGs. Drums that contain TRU waste would ultimately be processed and certified at WRAP and shipped to WIPP for disposal.

Environmental consequences from the proposed activity were estimated to occur mainly for workers, resulting in about 6 person-rem from direct exposure to radiation during the 5-year period of retrieval operations. No substantial emissions of chemicals or radionuclides were expected from routine

retrieval operations. Consequences of potential radiological or chemical releases from reasonably foreseeable accidents were within safety guidelines, and the number of industrial illnesses and injuries expected from the operation was small (up to 1 lost workday event). No serious or irreversible health effects to workers or members of the public were anticipated to occur from either accidents or routine operations. Because of the nature and location of the operations, other types of environmental impacts would be unlikely. Based on analyses in the EA, DOE determined the proposed action was not a major federal action significantly affecting the quality of the human environment and issued a FONSI on March 22, 2002.

- **West Valley Demonstration Project Waste Management Environmental Impact Statement (DOE/EIS-0337D April 2003)**

This EIS (DOE 2003e) describes the environmental impacts of the Department of Energy's proposed action to ship radioactive wastes that are either currently in storage, or that will be generated from operations over the next 10 years, from the West Valley Site to offsite disposal locations and to continue ongoing waste management activities at the site. Under DOE's preferred alternative, LLW and MLLW would be shipped to Hanford or the Nevada Test Site for disposal, TRU waste would be shipped to WIPP for disposal and vitrified HLW canisters would be shipped to Yucca Mountain for disposal. DOE's non-preferred alternative is the same as the preferred alternative with respect to LLW and MLLW. However, under DOE's non-preferred alternative, TRU waste and vitrified HLW could be sent to Hanford and/or other large DOE sites for interim storage until these wastes could be shipped to WIPP and Yucca Mountain, respectively.

- **Draft Supplemental Programmatic Environmental Impact Statement on Stockpile Stewardship and Management for a Modern Pit Facility (DOE/EIS-236-S2 May 2003)**

This SEIS evaluates alternatives for production of plutonium pits, an essential component of the nation's nuclear weapons (DOE 2003a). Plutonium pits were formerly manufactured at the DOE Rocky Flats Plant, which ceased production in 1989. The *Final Programmatic Environmental Impact Statement for Stockpile Stewardship and Management* evaluated alternatives for maintaining the nation's nuclear stockpile, including needs for pit manufacturing capability and capacity (DOE 1996a). As a result of the programmatic EIS, DOE decided to establish an interim pit production capability at the Los Alamos Site in New Mexico. The draft SEIS evaluated alternatives for increased pit production in the future, including expansion of the interim facility at Los Alamos, or constructing a new facility at Los Alamos, NTS, the Pantex Site in Texas, SRS in South Carolina, or the Carlsbad (WIPP) Site in New Mexico. DOE's preferred alternative identified in the draft SEIS was construction of a new facility, but neither its capacity nor location was specified. Estimated annual waste production at the new facility would range from 590 to 1,130 m<sup>3</sup> of TRU waste, 2,070 to 5,030 m<sup>3</sup> of LLW, and 1.7 to 4.2 m<sup>3</sup> of MLLW. Hanford was not considered as an alternative for siting the new pit production facility, but could potentially receive waste generated at the new facility under some alternatives where the primary site does not have the capability to manage such waste.

- **Environmental Assessment for the Accelerated Tank Closure Demonstration Project (DOE/EA-1462 June 2003)**

This EA was prepared for a project that would collect engineering and technical information to support preparation of the proposed Tank Closure EIS by a demonstration of closure activities for Single-Shell Tank 241-C-106 located in the 241-C Tank Farm (DOE 2003c). Activities associated with this Accelerated Tank Closure Demonstration project include stabilization of residual tank waste. Based on analyses in the EA, DOE determined the proposed action was not a major federal action significantly affecting the quality of the human environment and issued a FONSI on June 16, 2003.

- **Environmental Assessment. Deactivation of the Plutonium Finishing Plant, Hanford Site, Richland, Washington (DOE/EA-1469, September 2003)**

This EA describes activities and impacts related to deactivation of the Plutonium Finishing Plant complex (DOE 2003b). The principal actions evaluated include: 1) removing residual nuclear material inventory (approximately 100 kilograms [220 pounds]) present in the major buildings and other systems and structures within the PFP complex and 2) deactivation of the PFP complex. The projected end state of the PFP complex at completion of these activities would consist of deactivated structures (i.e., exterior walls, roofs, foundations and substructures) requiring minimal surveillance and maintenance before dismantlement. LLW, MLLW, and TRU waste generated by these activities could be transferred to the solid waste program for management. Based on analyses in the EA, DOE determined the proposed action was not a major federal action significantly affecting the quality of the human environment and issued a FONSI in October 2003.

### **1.5.3 Related State Environmental Policy Act (SEPA) Documents**

This section describes non-DOE documents for facilities that may be used as part of the overall Solid Waste Program for management of Hanford Site LLW and MLLW.

- **Draft Environmental Impact Statement. Commercial Low-Level Radioactive Waste Disposal Site, Richland, Washington, Washington State Department of Health (WDOH) and Washington State Department of Ecology (August 2000)**

WDOH and Ecology (2000) evaluated potential environmental consequences of operating a commercial LLW disposal facility located near the Hanford Site 200 East Area. The EIS evaluated renewal of the facility's operating license, establishing an upper limit on disposal rate for some types of LLW, and approval of the site stabilization and closure plan. The Hanford Site could dispose of some LLW at commercial facilities if there were cost or environmental benefits to using non-DOE disposal capacity. The final SEPA EIS had not been issued at the time of publication of the final HSW EIS.



- **Environmental Impact Statement for Treatment of Low-Level Mixed Waste, City of Richland (February 1998)**

The City of Richland, Washington, published a final SEPA EIS (City of Richland 1998) for operation of a MLLW treatment facility by ATG. The EIS analyzed impacts of construction and operation of the facility in Richland for treatment of MLLW from federal and private customers, including Hanford and potentially other DOE sites. The consequences of treating limited quantities of Hanford MLLW at this facility were also evaluated separately (DOE 1998, 1999a).

#### **1.5.4 Related CERCLA Documents**

- **Record of Decision. U.S. DOE Hanford Environmental Restoration Disposal Facility, Hanford Site, Benton County, Washington (January 1995)**

DOE and EPA decided to construct the Environmental Restoration Disposal Facility to dispose of radioactive and mixed waste from cleanup of the Hanford Site (DOE, EPA, and Ecology 1995). The ROD was subsequently amended to expand the facility (DOE, EPA, and Ecology 1997) and to delist the leachate collected at the facility (DOE, EPA, and Ecology 1999).

- **Record of Decision, U.S. Department of Energy, Hanford 300 Area, Hanford Site, Benton County, Washington (April 2001)**

DOE, EPA, and Ecology decided that interim remedial actions for portions of the 300 Area would include removal of contaminated soil, structures, and associated debris; treatment, if needed, to meet waste acceptance criteria at an acceptable disposal facility; disposal of contaminated materials at ERDF, WIPP, and other EPA-approved disposal facilities; recontouring and backfilling excavated areas followed by infiltration control measures; institutional controls to ensure that unanticipated changes in land use that could result in unacceptable exposures to residual concentration do not occur; ongoing groundwater and ecological monitoring to ensure effectiveness of remedial actions; and the regulatory framework for accelerating future remediation decisions (EPA 2001). The cleanup plan and schedules would include specific commitments regarding the decontamination and decommissioning of facilities and aboveground structures needed to complete cleanup of underlying waste sites in the 300 Area Complex and the remediation plans for the 618-10 and 618-11 Burial Grounds.

## **1.6 NEPA Process for the HSW EIS**

The formal NEPA process for preparing the HSW EIS is described in the following sections. The typical process begins with DOE issuing a Notice of Intent (NOI) to prepare an EIS, followed by the scoping period, during which public input is sought on the scope of the EIS. The draft EIS is prepared following the scoping period, and the draft is issued for public comment. EPA publishes a *Federal Register* Notice of Availability (NOA) for the draft EIS at the beginning of the public comment period, which lasts a minimum of 45 days. Following public comment on the draft, the final EIS is prepared,

ultimately leading to a Record of Decision on the proposed action. The ROD is published no sooner than 30 days after the EPA Notice of Availability for the final EIS, after which DOE may proceed with the activity under consideration.

### 1.6.1 Scoping for the Draft HSW EIS

The scope of an EIS consists of the range of actions, alternatives, and impacts to be considered (40 CFR 1508.25). Scoping is a public process used by DOE to help identify significant issues related to a proposed action. As part of that process, DOE invited comments and recommendations from interested parties on the scope of this HSW EIS.

DOE decided to prepare the HSW EIS in early 1997, following publication of the draft WM PEIS, but before DOE issued the final WM PEIS in May of 1997. The formal Notice of Intent to prepare the HSW EIS was published in the October 27, 1997 *Federal Register* (62 FR 55615), in accordance with applicable NEPA regulations. The NOI announced the schedule for the public scoping process and summarized the proposed alternatives and environmental consequences to be considered in the EIS.

- **Public Comment Period** – Originally scheduled from October 27, 1997 through December 11, 1997, the comment period was extended to 95 days by DOE through January 30, 1998, in response to a request from the State of Oregon. The Notice of Extension appeared in the December 11, 1997, *Federal Register* (62 FR 65254).
- **Public Scoping Meetings** – Scoping meetings were held in Richland, Washington, on November 12, 1997, followed by a meeting in Pendleton, Oregon, on November 13, 1997. Opportunities were provided at each meeting for informal discussion, as well as formal comments, about the DOE proposed action and the scope and content of the HSW EIS.
- **Scoping Results** – Both oral and written comments were received at the public scoping meetings. Written comments were also accepted by conventional and electronic mail. All written and oral comments were considered in preparing the draft HSW EIS. Commenters provided comments on several topics: relationship to other NEPA documents and DOE activities, alternatives and activities to analyze, waste types and volumes to analyze, environmental consequences, and public involvement and government agency consultation. During preparation of the draft HSW EIS the nature of the alternatives evolved as a result of the scoping comments and publication of the WM PEIS RODs. A summary of the scoping comments and the DOE responses is included in Volume II, Appendix A of this HSW EIS.

### 1.6.2 Publication of the First Draft HSW EIS

The first draft HSW EIS was approved by DOE in April 2002 (DOE 2002b), and the EPA Notice of Availability was published on May 24, 2002 (67 FR 36592). The scope of the first draft HSW EIS included storage, treatment, and disposal of LLW and MLLW (including WTP melters) at Hanford, and processing and certification of TRU waste for disposal at WIPP. The scope of transportation analysis included shipment of onsite and offsite generated waste within the Hanford Site boundary, and shipment

of some MLLW to offsite facilities for treatment and return to Hanford. Most offsite transportation of LLW, MLLW, and TRU waste to Hanford was evaluated in the WM PEIS and the WIPP SEIS-II (DOE 1997c, 1997d), and those evaluations were referenced in the first draft HSW EIS.

### **1.6.3 Public Comments on the First Draft HSW EIS**

The public comment period for the first draft HSW EIS extended for 90 days from publication of the NOA on May 24, 2002 through August 22, 2002. Approximately 3800 comments were received from 700 individuals, organizations, or agencies via mail, electronic mail, and at public meetings. A total of six public meetings were held in Richland and Seattle, Washington, on August 6 and 7, respectively; and in LaGrande and Hood River, Oregon on July 23, and August 14, 2002, respectively. Two meetings were held in Portland, Oregon on July 30 and August 21, 2002. The public meetings provided opportunity for informal discussion before the meeting, a brief DOE presentation on the draft HSW EIS, presentations by regulatory agencies and local interest groups, and a question-and-answer session, in addition to the formal public comments. Forms for submitting written comments were also available at each meeting. Each comment was considered in preparing the revised draft HSW EIS, and many comments resulted in changes to the document.

Comments on the first draft HSW EIS generally were related to the following major issues:

- DOE's role in Hanford cleanup
- NEPA process: a number of comments questioned whether the HSW EIS complied with all NEPA requirements
- integration with other DOE programs and NEPA decisions: comments expressed concern that the HSW EIS be consistent with recent DOE proposals to accelerate cleanup at DOE sites and with recent NEPA decisions
- public involvement process: comments questioned the procedures used to notify members of the public about hearings on the draft HSW EIS, as well as the meeting process itself
- scope of transportation analysis: comments questioned the appropriateness of the WM PEIS transportation analysis and the decision not to repeat that nationwide analysis in the HSW EIS
- technical content and scope of the HSW EIS: comments 1) pointed out perceived omissions or inaccuracies in the HSW EIS technical analyses, alternatives, and scope of the EIS, and 2) requested evaluation of additional alternatives for waste treatment and disposal
- disposal facility design and long-term performance: there were numerous concerns regarding use of unlined trenches for disposal of LLW, as well as concerns about contamination of groundwater and the Columbia River

- importation of offsite waste to Hanford: comments expressed concern regarding the impact of additional offsite waste on the Hanford Site environment, as well as on other cleanup activities at Hanford.

An overview of the way in which DOE addressed each major issue, and the responses to specific comments received on the first draft HSW EIS, were included in the comment response volume (Volume III) of the revised draft HSW EIS.

#### **1.6.4 Scoping for the ILAW Disposal SEIS**

DOE prepared the TWRS EIS (DOE and Ecology 1996) to evaluate disposition of Hanford's high-level tank waste, as noted previously. As part of the TWRS EIS ROD (62 FR 8693), DOE planned to place ILAW into concrete vaults in the 200 East Area. DOE subsequently began to examine alternative plans for disposing of ILAW in onsite near-surface facilities. Following a supplement analysis of disposal options for ILAW (DOE 2001g), DOE decided additional NEPA review was required, and a Notice of Intent to prepare a SEIS was issued on July 8, 2002 (67 FR 45104). Alternatives under consideration included the following:

- Change ILAW from a vitrified cullet form (granular glass particles similar to pea gravel) to a monolithic (single large) vitrified waste form in canisters.
- Change interim retrievable storage of ILAW in vaults to disposal in near-surface regulatory-compliant trenches of various configurations.
- Consider ILAW disposal at other potential sites within the 200 East and 200 West Areas.

The proposed changes were intended to be more cost effective and efficient with respect to land and other resource use. Worker safety and compatibility of the ILAW form with the engineered facility were also considerations.

Following the Notice of Intent to prepare the ILAW disposal SEIS, DOE held a scoping meeting in Richland, Washington, on August 20, 2002, and received oral and written comments during the 49-day scoping period. During scoping and preparation of a working draft SEIS, meetings were held in Seattle, Washington and Portland, Oregon. In addition, meetings were held with the Yakama Nation, Hanford Communities, Hanford Natural Resource Trustee Council, Oregon Office of Energy, and the Hanford Advisory Board. The scoping comments and questions centered on the following major themes:

- requests for technical information and clarification
- ILAW disposal alternatives
- long-term performance, mitigation, and stewardship
- ILAW form and treatment alternatives
- cumulative impacts
- regulatory, legal, and NEPA issues

- waste classification, definition of ILAW and HLW
- other impacts and analyses
- relationship to the HSW EIS and other NEPA documents
- public involvement process
- relationship to current DOE cleanup plans
- Native American treaty issues
- opposition to disposal or storage of ILAW at Hanford.

Appendix A in Volume II of this HSW EIS contains a summary of comments received on the scope of the ILAW SEIS. After scoping for the ILAW disposal SEIS, DOE decided to address ILAW disposal alternatives in the revised draft HSW EIS, and therefore terminated its preparation of the ILAW SEIS (68 FR 7110). The HSW EIS provides a NEPA review for ILAW disposal in addition to Solid Waste Program operations evaluated in the first draft HSW EIS (DOE 2002b).

### **1.6.5 Revised Draft HSW EIS**

The revised draft HSW EIS (DOE 2003d) was distributed for review and comment to the general public, members of Congress, appropriate federal agencies, interested governmental organizations, and affected state, tribal, and local governments. Stakeholders were notified of the upcoming publication of the HSW EIS, and were given the opportunity to request the document in several formats. The entire document was distributed as required or upon request. Other individuals who had requested the first draft HSW EIS or who requested the revised draft were provided a summary of the revised draft EIS with the complete document on compact disk. The revised draft HSW EIS addressed new waste management alternatives that had been developed since the first draft HSW EIS was issued in April 2002 (DOE 2002b). The alternatives were developed after review of the Hanford Site Performance Management Plan prepared in August 2002 (DOE-RL 2002b), discussions with regulatory agencies and stakeholders (DOE-RL 2002a), and in response to public comments. It also incorporated alternatives for onsite disposal of ILAW, as discussed in the previous section. In response to requests for additional information regarding offsite transportation risks, the revised draft HSW EIS included an expanded discussion of transportation consequences based on the analyses in the WM PEIS and the WIPP SEIS-II. Expanded analyses included evaluation of waste from Hanford generators to clearly distinguish the incremental impacts of importing various quantities of waste from other DOE sites.

Because of the substantial changes relative to the first draft HSW EIS, DOE elected to issue the revised draft for public comment. The public involvement process was similar to that for the first draft HSW EIS. The revised draft HSW EIS was approved by DOE in March 2003, and the EPA Notice of Availability was issued on April 11, 2003 (68 FR 17801). The public review period for the revised draft was initially scheduled to close on May 27, 2003 but was extended to 62 days, ending on June 11, 2003 (68 FR 28821, 68 FR 32486). In addition to soliciting written comments, DOE held public hearings to receive oral and written comments on the revised draft HSW EIS. Meetings were held in Richland, Spokane, and Seattle, Washington, on May 1, 7, and 15, respectively; and in LaGrande, Portland, and Hood River, Oregon, on May 12-14. The schedule for public review and hearings was announced in local media and by direct mailing to stakeholders.

Issues raised during public review of the revised draft HSW EIS were similar to those expressed during review of the first draft: concerns about importing waste to Hanford from offsite facilities; transportation risks, contamination of soil and groundwater, waste disposal impacts on human health and the environment; and specific points regarding assumptions and methods used for various impact analyses. Because the scope of the HSW EIS was expanded to include disposal of ILAW, additional issues regarding Hanford tank waste treatment were raised, including classification of LAW for onsite disposal, pretreatment of tank waste to remove technetium-99, alternative treatment technologies for LAW, and other issues related to closure of the tanks. Public involvement concerns were also expressed, including several requests for extension of the public comment period for the revised draft. The comment response document (Volume III of this final HSW EIS) presents DOE responses to these comments. Written comments and public meeting transcripts are reproduced in Volume IV of this EIS.

### **1.6.6 Preparation of the Final HSW EIS and Record(s) of Decision**

Following the public comment period and after considering the comments received on the revised draft HSW EIS, DOE prepared this final HSW EIS. DOE considered all comments received during the public comment period on the revised draft HSW EIS, which are addressed in the Comment Response Document (Volume III). A number of commenters on the revised draft HSW EIS requested that DOE make changes or provide additional information, and DOE did so where appropriate. These revisions are not a result of any significant new circumstances or information that became available since publication of the revised draft HSW EIS. For example, DOE provided additional details on the relationship between the HSW EIS and other NEPA documents, including the Waste Management Programmatic EIS and the West Valley Demonstration Project Waste Management EIS; the analysis of the impacts of offsite waste (including an updated transportation analysis); evaluation of long-term performance, particularly with respect to the groundwater; and DOE's approach to, and analysis of, cumulative impacts. As a result, this final HSW EIS incorporates various changes to discussions that appeared in the revised draft HSW EIS, and it provides additional details and supplemental analyses concerning potential environmental impacts. Throughout Volumes I and II of this final HSW EIS, DOE has indicated these changes with "change bars" in the margins of the affected pages. The final HSW EIS has been distributed to individuals and organizations that received the revised draft HSW EIS and to others upon request.

No sooner than 30 days after the EPA Notice of Availability for the final HSW EIS is published in the *Federal Register*, DOE may issue one or more RODs for actions described in the final HSW EIS. In addition to the environmental consequences described in this final HSW EIS, DOE may evaluate other issues such as cost, programmatic considerations, and national needs in making its decisions.

If mitigation measures, monitoring, or other conditions are adopted as part of a DOE decision, they will be summarized in the ROD(s), if applicable, and a mitigation action plan will be prepared. The ROD(s) and mitigation action plan, if needed, will be placed in the DOE Reading Room in Washington, D.C., and in the DOE Public Reading Room at Washington State University, Tri-Cities Campus, in Richland, Washington. They will also be available to interested parties upon request.

## 1.7 Scope of the HSW EIS

This HSW EIS addresses proposed actions and alternatives for managing four major waste types: LLW, MLLW, TRU waste, and ILAW. It updates previous Hanford NEPA reviews to incorporate alternatives developed after those reviews were completed, and evaluates or updates assessments of site-specific impacts at Hanford associated with activities described in the WM PEIS (DOE 1997c). Hanford waste management operations include the three major functions of storage, treatment, and disposal. Alternatives evaluated in this EIS address continued operation and expansion of ongoing waste management operations to accommodate future waste receipts. A range of waste volumes is evaluated for each alternative in order to encompass the quantities of waste that might be received at Hanford for management in the future.

### 1.7.1 Waste Types Evaluated in the HSW EIS

The types of waste evaluated in the HSW EIS are described in the following sections. Descriptions of the specific waste streams within each waste type and their management alternatives at Hanford are presented in Section 2 and Section 3, respectively. Throughout the HSW EIS, the LLW, MLLW, TRU waste, ILAW, and WTP melters that are evaluated within the scope of the document are referred to collectively as Hanford solid waste (HSW). This designation is not meant to be all-inclusive of various wastes present at Hanford, but is used as a convenience in describing the impacts of the wastes considered in this document relative to other types of waste and activities at the Hanford Site.

#### 1.7.1.1 Low-Level Waste

LLW is waste that contains radioactive material and that does not fall under any other DOE classification of radioactive waste. DOE manages LLW and other radioactive waste under the authority of the Atomic Energy Act (AEA) of 1954 (42 USC 2011). At Hanford, LLW may be further divided into Category 1 (Cat 1), Category 3 (Cat 3), or greater than Category 3 (GTC3) LLW, depending on the specific characteristics and quantities of radioactive material that it contains, as defined in the *Hanford Site Solid Waste Acceptance Criteria* (HSSWAC) (FH 2003). LLW streams managed at Hanford are described in Section 2.1.1.

LLW and other radioactive wastes are also classified as either contact-handled (CH) or remote-handled (RH), depending on radiation dose rates as measured in contact with the container surface.

#### **Contact-Handled (CH) and Remote-Handled (RH) Waste**

Contact-handled waste containers produce radiation dose rates less than or equal to 200 millirem/hour at the container surface. RH waste containers produce dose rates greater than 200 millirem/hour. CH containers can be safely handled by direct contact using appropriate health and safety measures. RH containers require special handling or shielding during waste management operations. These designations can apply to LLW, MLLW, TRU waste, and ILAW.

### **1.7.1.2 Mixed Low-Level Waste**

MLLW is LLW that also contains hazardous components as defined by the Resource Conservation and Recovery Act (RCRA) of 1976 (42 USC 6901) and applicable state regulations. Hazardous waste requirements became applicable to DOE waste in 1987. The hazardous components of MLLW are regulated under applicable RCRA or state regulations (40 CFR 260-280; WAC 173-303). The radioactive components of MLLW are regulated by DOE under the AEA (42 USC 2011). MLLW streams managed at Hanford are described in Section 2.1.2. Additional discussion of regulations for managing radioactive and hazardous wastes at Hanford is provided in Section 6.

### **1.7.1.3 Transuranic Waste**

TRU waste contains greater than specified quantities of TRU radionuclides as defined in Section 2.1.3. Mixed TRU waste also contains non-radioactive hazardous constituents. The radioactive components of all TRU waste are regulated under the AEA (42 USC 2011). The hazardous constituents in TRU waste are regulated under applicable RCRA or state regulations (40 CFR 260-280; WAC 173-303). TRU waste must be characterized, packaged, and certified as meeting the WIPP waste acceptance criteria before it can be shipped to that facility for disposal.

TRU waste was not defined as a separate waste type until 1970. From 1970 through 1988, waste suspected of containing TRU radionuclides was retrievably stored in the Hanford LLBGs. This waste is referred to as suspect TRU waste because only part of the stored waste contains TRU radionuclides at concentrations specified in the current definition for TRU waste. Since 1988, TRU waste has generally been stored in surface facilities until it can be processed and certified for disposal at WIPP.

DOE previously decided to characterize the retrievably stored waste and recover the containers that are determined to contain TRU waste for processing and shipment to WIPP (DOE 1987). DOE plans to characterize the retrievably stored waste to determine which containers should be processed as TRU waste (DOE 2002c). TRU waste managed by the Hanford Solid Waste Program is described in Section 2.1.3.

### **1.7.1.4 Immobilized Low-Activity Waste and Melters from the Hanford Tank Waste Treatment Plant**

For purposes of analysis in this HSW EIS, ILAW and melters from the WTP are assumed to be managed and disposed of as RH MLLW. The first draft HSW EIS evaluated disposal of the WTP melters as part of the pretreated MLLW waste stream, but did not address disposal of ILAW. In the revised draft and this final EIS, the WTP melters and ILAW are evaluated separately from other MLLW because the physical requirements for onsite transport, handling, and disposal differ from those typically used for most routine operational LLW and MLLW.

Hanford tank waste is presently considered mixed waste from a regulatory perspective. Based on the *Remote-Handled Immobilized Low-Activity Waste Disposal Facility Environmental Permits and Approval Plan* (Deffenbaugh 2000), the recommended approach for ILAW disposal in this document would be to



follow the normal state and RCRA permitting process. However, there are other regulatory processes that could allow DOE to dispose of ILAW consistent with RCRA requirements, including petitioning for variance, rulemaking, and/or delisting.

### 1.7.2 Waste Volumes Evaluated in the HSW EIS

Unless stated otherwise, environmental consequences in the HSW EIS have been evaluated for three waste volumes: a Hanford Only, a Lower Bound, and an Upper Bound waste volume. Because of uncertainty about future waste receipts, these alternative waste volume scenarios were evaluated to encompass the range of quantities that might be received.

- The **Hanford Only** waste volume consists of 1) the forecast volumes of LLW, MLLW, and TRU waste from Hanford Site generators, 2) the forecast ILAW and WTP melter volumes from treatment of Hanford tank waste, and 3) existing onsite inventories of waste that are already in storage. The analysis also includes waste that has previously been disposed of in the LLBGs.
- The **Lower Bound** waste volume consists of 1) the Hanford Only volume, and 2) additional volumes of LLW and MLLW that are currently forecast for shipment to Hanford from offsite facilities. The Lower Bound volume for TRU waste is not substantially greater than the Hanford Only volume, and is not analyzed separately in all cases.
- The **Upper Bound** waste volume consists of 1) the Lower Bound volume, and 2) estimates of additional LLW, MLLW, and TRU waste volumes that may be received from offsite generators consistent with the WM PEIS decisions.

The first draft HSW EIS evaluated consequences for the Lower and Upper Bound waste volumes. The Hanford Only waste volume was included in the revised draft HSW EIS and this final EIS so the incremental impacts of managing all offsite waste can be clearly evaluated. The bases for waste volumes evaluated in the HSW EIS are discussed further in Section 3.3 and Volume II, Appendix C.

### 1.7.3 Hanford Waste Management Alternatives Evaluated in the HSW EIS

This HSW EIS considers a range of reasonable alternatives for management of solid LLW, MLLW, TRU waste, WTP melters, and ILAW at the Hanford Site to support DOE decisions regarding management of these wastes. The waste management alternatives included within the scope of this HSW EIS are described briefly in the following sections. Hanford Solid Waste Program activities include storage, treatment, and disposal of LLW and MLLW, as well as storage, processing, and certification of TRU waste for shipment to WIPP. The HSW EIS also evaluates alternatives for onsite disposal of ILAW and melters from the WTP. In its ROD(s), DOE could choose to implement a combination of actions from any of the alternatives evaluated in this EIS. Existing and proposed waste management facilities considered in the HSW EIS alternatives are described in Section 2.2. The action and no action alternatives for managing these wastes are described further in Section 3.1. In this EIS, the no action alternative consists of continuing ongoing activities, but does not include development of new capabilities to manage wastes that cannot currently be disposed of.

### 1.7.3.1 Storage

Waste is generally stored while awaiting treatment or disposal. The specific storage methods used depend on the chemical and physical characteristics of the waste as well as the type and concentration of radionuclides in the waste.

In most cases, alternatives for storage of LLW, MLLW, and TRU waste consist of using existing or planned capabilities at the Central Waste Complex (CWC), T Plant, the LLBGs, or other onsite facilities. Except for the No Action Alternative, additional storage capacity is not expected to be necessary to accommodate future waste receipts. As waste in storage is treated, processed, or certified for disposal, space would become available for storage of newly received waste. The consequences of operating storage facilities needed to manage Hanford solid waste are included in the HSW EIS to provide a complete assessment and to bound the potential impacts associated with the proposed action. Conservative assumptions are used to provide flexibility in the event of future minor revisions to facility activities.

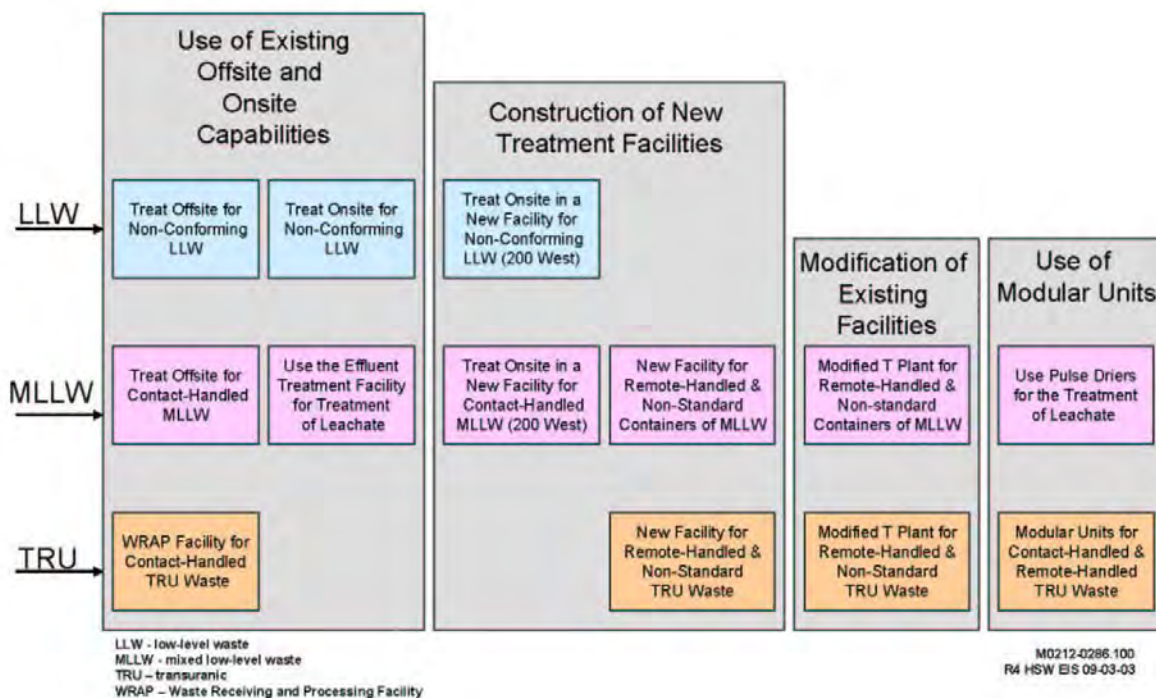
In the No Action Alternative, treatment and processing capabilities would not be available for all waste types, and any wastes that could not be disposed of would require storage. The analysis in this EIS assumes expansion of the CWC to accommodate most untreated LLW, MLLW, and TRU waste, and WTP melters and treated MLLW that exceeds existing disposal capacity. The No Action Alternative for ILAW includes construction of concrete vaults in the 200 East Area for interim storage consistent with the TWRS EIS ROD (62 FR 8693).

### 1.7.3.2 Treatment

Treatment action alternatives examined in this HSW EIS are shown in Figure 1.5. These alternatives apply two different approaches to processing wastes for disposal.

- **The first approach** would maximize the use of offsite treatment and develop additional onsite capacity to treat waste that could not be accepted at offsite facilities. The alternatives that would maximize use of offsite treatment would include actions DOE previously identified as the preferred alternative for treatment of LLW, MLLW, and TRU waste in the previous drafts of the HSW EIS. In general, those actions are expected to minimize environmental impacts by using or modifying existing onsite and offsite facilities for treatment, processing, and certification of waste. Non-conforming LLW would be treated to comply with the HSSWAC at offsite commercial facilities if treatment capacity does not exist at Hanford. DOE would establish additional contracts with a permitted commercial facility (or facilities) to treat most of Hanford's CH MLLW using both thermal and non-thermal processes. For MLLW and TRU waste that cannot be treated at existing facilities, such as RH or non-standard items, DOE would develop new onsite treatment capacity by modifying facilities in the T Plant Complex.
- **The second approach** for acquiring new treatment capacity would maximize the use of onsite treatment capabilities. Under this approach, the alternatives include activities that maximize treatment of MLLW and non-conforming LLW onsite at Hanford. These alternatives are expected to result in the maximum environmental impacts for operations because they include more onsite

activities and construction of a new onsite facility (or facilities) to process some LLW, MLLW and TRU waste. The new waste processing facility would be used to treat non-conforming LLW to comply with the HSSWAC if treatment capacity does not currently exist at Hanford. Except for the limited quantities treated under existing commercial contracts, most of Hanford's CH MLLW would be treated at a new facility using non-thermal processes (including alternatives to thermal processing for some wastes). The new facility would also be used to process MLLW and TRU waste that cannot be accepted at existing facilities, such as RH or non-standard items.



**Figure 1.5.** Treatment Action Alternatives (ILAW treatment alternatives are evaluated under the TWRS EIS [DOE and Ecology 1996])

In the No Action Alternative, only existing capacity for waste treatment would be used. Some non-conforming LLW, untreated MLLW, and TRU waste that cannot be processed or certified at WRAP would not be suitable for disposal, and those wastes would be stored onsite.

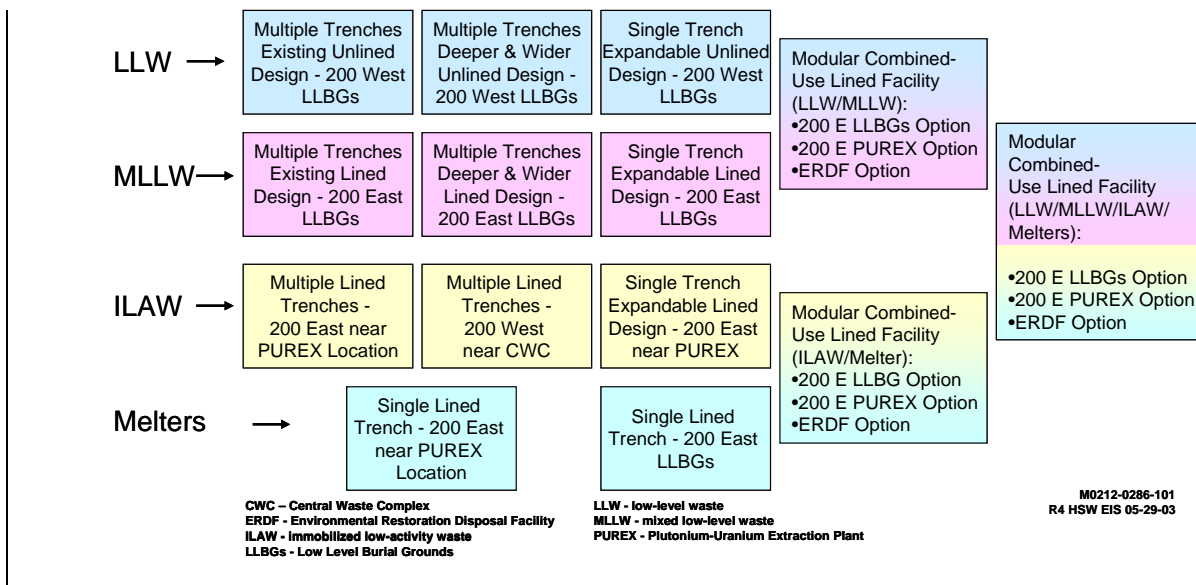
### 1.7.3.3 Disposal

The final step in the waste management process is disposal. Some types of radioactive and mixed waste can be disposed of safely in existing facilities using conventional methods such as near-surface disposal. Other types of waste require facilities that provide long-term isolation, such as a repository. Disposal facilities at Hanford accept waste suitable for near-surface disposal. Any waste from Hanford or other facilities that requires long-term isolation would ultimately be sent to a repository such as WIPP or

Yucca Mountain. This EIS evaluates alternatives or updates previous plans for permanent disposal of LLW, MLLW, ILAW, and WTP melters at Hanford, including expansion, possible reconfiguration, and closure of onsite disposal facilities.

**Alternatives for Waste Disposal.** Alternatives in this HSW EIS assume continued use of disposal capabilities that currently exist at Hanford until new disposal capacity can be developed and permitted. DOE would construct additional disposal capacity for LLW and MLLW. New disposal facilities would also be constructed to receive ILAW and WTP melters based on the schedule for startup and operation of the WTP. All disposal facilities would meet applicable state and federal requirements. Facilities for disposal of MLLW, ILAW, and WTP melters would be constructed to applicable regulatory standards with double liners and leachate collection systems. LLW disposal in either lined or unlined trenches is evaluated in various alternatives. By the end of operations, all disposal facilities would be closed by applying a regulatory-compliant cap to reduce water infiltration and the potential for intrusion.

Several different configurations and locations are evaluated for new disposal facilities needed to manage each waste type. The disposal action alternatives are shown in Figure 1.6. Section 3 contains a description of these disposal alternatives as evaluated in the HSW EIS. An overview of the configuration and location alternatives is as follows:



**Figure 1.6.** Disposal Action Alternatives

- **Disposal Configuration Alternatives:** Alternatives for disposal configuration include various options for the number and size of trenches, including facilities dedicated to a single type of waste and options for combined disposal of two or more waste types. Alternatives for segregated disposal of LLW or MLLW consist of multiple trenches similar to those currently employed for each waste type, multiple trenches of a deeper and wider configuration, or a single expandable trench for each waste type. Similarly, ILAW disposal is evaluated using multiple trenches or a single expandable

trench. The independent disposal alternative for WTP melters considers a single dedicated trench because of their relatively small overall volume, and because of constraints imposed by the size and weight of individual waste packages.

Alternatives for combined disposal of two or more waste types are also evaluated. The HSW EIS considers alternatives that include two combined-use disposal facilities: one for combined disposal of LLW and MLLW, and one for combined disposal of ILAW and WTP melters. In addition, disposal of all waste types in a single combined-use facility is evaluated. Disposal in combined-use facilities might involve construction of separate modules for wastes with different characteristics, to ensure that wastes placed in the same module are suitable for disposal together and are compatible with the engineered disposal system.

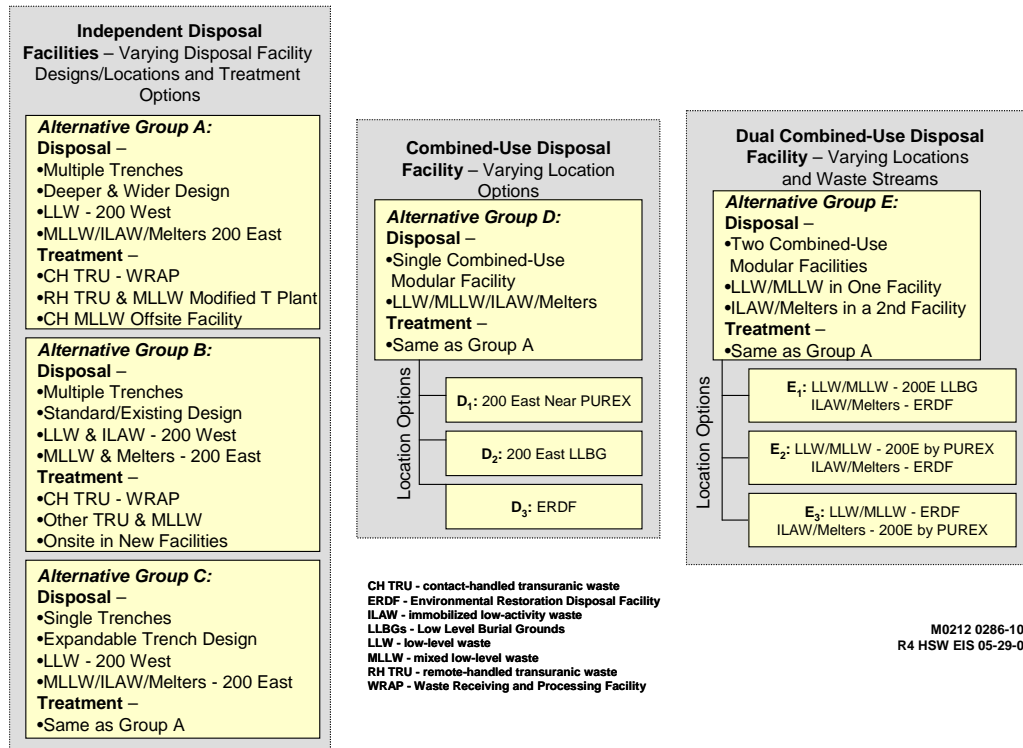
- **Disposal Location Alternatives:** The HSW EIS disposal alternatives consider several different locations for new or expanded disposal facilities, including use of LLBGs in the 200 West and 200 East Areas. New disposal sites in the 200 West Area near the CWC and in the 200 East Area near the PUREX Facility are also evaluated. Some alternatives involving combined-use disposal facilities evaluated the use of ERDF. However, such an arrangement would require modifications to the ERDF waste acceptance criteria, as well as to conditions specified in the TPA. A revision to the CERCLA ROD for ERDF might also be necessary.

In the No Action Alternative, LLW would continue to be disposed of in LLBG trenches of a design currently employed. The trenches would be backfilled but would not be capped. The two existing MLLW trenches would be filled to capacity and capped in accordance with applicable regulations. MLLW that exceeds the trench capacity, including WTP melters, would be stored onsite. ILAW would be placed in concrete vaults in the 200 East Area, consistent with the TWRS EIS ROD (62 FR 8693).

#### 1.7.3.4 Grouping of Alternatives

In developing the alternatives for this HSW EIS, there are a large number of combinations of the various waste streams, their potential waste volumes, and individual options for their storage, treatment, and disposal. To facilitate the analysis and presentation of impacts, these alternatives and options were combined into five primary alternative groups. Alternatives for the treatment, storage, and disposal of the different waste types were included in each alternative group, in addition to a range of potential waste volumes. The alternative groups have been identified as A, B, C, D, and E. A No Action Alternative was also evaluated as required under NEPA. For Alternative Groups D and E, several different potential locations were evaluated for the disposal facility(s) within the 200 East and 200 West Areas. With the exception of the No Action Alternative, each alternative is consistent with WM PEIS RODs. For LLW, MLLW, and TRU wastes, Alternative Group A, Alternative Group B, and the No Action Alternative are fundamentally the same as Alternative 1, Alternative 2, and the No Action Alternative, described in the first draft of this HSW EIS (DOE 2002b). Alternative Groups C, D, and E (and their options) were added in the revised draft HSW EIS (DOE 2003d). The structure of the alternative groups remains the same in this final EIS. Figure 1.7 illustrates the alternatives included in each of these alternative groups.

**No Action Alternative.** The No Action Alternative consists of continuing current solid waste management practices, including continued storage of radioactive wastes that cannot be processed for disposal. As part of the No Action Alternative, RODs and other NEPA decisions for existing facilities and operations would be implemented and ongoing activities would continue, consistent with the Council on Environmental Quality guidelines. This is the “no action” alternative for an ongoing activity, where the EIS assumes there is no change from existing operations. For example, Hanford would continue to dispose of LLW and some MLLW within the Low Level Burial Grounds, and to certify and ship CH TRU waste to WIPP.



**Figure 1.7.** Development of Alternative Groups

Two other variations of the No Action Alternative are discussed within the context of this document. A “Stop Action” scenario is described, in which ongoing waste management operations would cease. This scenario was not considered reasonable and was therefore not evaluated in detail (See Section 3.2.4). In addition, a scenario in which waste disposal at Hanford is discontinued, but other ongoing waste management activities proceed, is discussed and evaluated in Volume II, Appendix M.

**Action Alternatives.** The action alternative groups as formulated for analysis in this EIS are described in the following sections. All of the action alternatives assume continued use of existing waste management capabilities and facilities, such as the use of WRAP to process and certify CH TRU waste and use of existing disposal capacity until new disposal facilities can be designed, permitted, and

constructed. Alternatives for development of new waste management capabilities needed at Hanford are encompassed within the alternative groups described in this section.

**Alternative Group A – Disposal by Waste Type in Larger Disposal Facilities – Onsite and Offsite Treatment:** New LLW and MLLW disposal trenches would be deeper and wider than those currently in use. New LLW disposal capacity would be located in the 200 West Area and new MLLW, ILAW, and WTP melter disposal facilities would be located in the 200 East Area. T Plant would be modified to provide processing and treatment capabilities for remote-handled TRU waste, remote-handled MLLW, and waste in non-standard containers. Treatment of most contact-handled MLLW in standard containers would be provided at offsite facilities. Operations at WRAP would continue to process contact-handled TRU waste for disposal at WIPP. Mobile processing facilities (Accelerated Process Lines, or APLs) would also be used for processing and certification of TRU waste to accelerate preparation of the waste for disposal at WIPP.

**Alternative Group B – Disposal by Waste Type in Existing Design Disposal Trenches – Onsite Treatment:** Disposal trenches for LLW and MLLW would be of the same design as those currently in use. New LLW and ILAW trenches would be located in the 200 West Area and new MLLW and WTP melter trenches would be located in the 200 East Area. A New Waste Processing Facility would be built to provide processing and treatment capabilities for remote-handled TRU waste, remote-handled and contact-handled MLLW, and waste in non-standard containers. Operations at WRAP would continue to process contact-handled TRU waste for disposal at WIPP. Mobile processing facilities (APLs) would also be used for processing and certification of TRU waste to accelerate preparation of the waste for disposal at WIPP.

**Alternative Group C – Disposal by Waste Type in Expandable Design Facility – Onsite and Offsite Treatment:** A single, expandable disposal facility (similar to the Environmental Restoration Disposal Facility) would be used for each waste type. A new LLW facility would be located in the 200 West Area and new MLLW, ILAW, and WTP melter facilities would be located in the 200 East Area. Treatment alternatives would be the same as those described for Alternative Group A.

**Alternative Group D – Single Combined-use Disposal Facility – Onsite and Offsite Treatment:** LLW, MLLW, ILAW, and WTP melters would be disposed of in a single facility. Disposal would occur either near the PUREX Plant (D<sub>1</sub>), in the 200 East Area Low Level Burial Grounds (D<sub>2</sub>), or at the Environmental Restoration Disposal Facility (D<sub>3</sub>). Treatment alternatives would be the same as those described for Alternative Group A.

**Alternative Group E – Dual Combined-use Disposal Facilities – Onsite and Offsite Treatment:** LLW and MLLW would be disposed of in one combined-use facility; ILAW and WTP melters would be disposed of in another combined-use facility. Disposal would occur in some combination of locations as shown in Figure 1.7. Treatment alternatives would be the same as those described for Alternative Group A.

## 1.7.4 Environmental Impact Analyses in the HSW EIS

Analyses of environmental consequences from waste management operations in the HSW EIS include assessment of impacts in the following areas as required by NEPA:

- land use
- air quality
- water quality
- geologic resources
- ecological resources
- socioeconomics
- cultural resources
- transportation
- noise
- health and safety
- aesthetic and scenic resources
- environmental justice
- cumulative impacts
- irreversible and irretrievable commitments of resources
- unavoidable adverse impacts
- potential mitigation measures.

Changes to the environmental consequences analysis in this final HSW EIS as a result of public comments include additional evaluation of the impacts on groundwater quality, ecological impacts, and additional analysis of the offsite transportation consequences. The cumulative impacts analysis is also more comprehensive.

## 1.8 References

10 CFR 61. “Licensing Requirements for Land Disposal of Radioactive Waste.” Code of Federal Regulations. Online at: [http://www.access.gpo.gov/nara/cfr/waisidx\\_03/10cfr61\\_03.html](http://www.access.gpo.gov/nara/cfr/waisidx_03/10cfr61_03.html)

10 CFR 1021. “National Environmental Policy Act Implementing Procedures.” Code of Federal Regulations. Online at: [http://www.access.gpo.gov/nara/cfr/waisidx\\_02/10cfr1021\\_02.html](http://www.access.gpo.gov/nara/cfr/waisidx_02/10cfr1021_02.html)

40 CFR 191. “Environmental Radiation Protection Standards for Management and Disposal of Spent Nuclear Fuel, High-level and Transuranic Radioactive Wastes.” Code of Federal Regulations. Online at: [http://www.access.gpo.gov/nara/cfr/waisidx\\_01/40cfr191\\_01.html](http://www.access.gpo.gov/nara/cfr/waisidx_01/40cfr191_01.html)

40 CFR 260-280. “Hazardous Waste Management System.” Code of Federal Regulations. Online at: [http://www.access.gpo.gov/nara/cfr/waisidx\\_02/40cfrv22\\_02.html](http://www.access.gpo.gov/nara/cfr/waisidx_02/40cfrv22_02.html)



40 CFR 1500-1508. "Council on Environmental Quality Regulations for Implementing the Procedural Provisions of the National Environmental Policy Act." Code of Federal Regulations. Online at: [http://www.access.gpo.gov/nara/cfr/waisidx\\_01/40cfrv28\\_01.html](http://www.access.gpo.gov/nara/cfr/waisidx_01/40cfrv28_01.html)

49 FR 47649. "National Environmental Policy Act Record of Decision for Disposal of Decommissioned, Defueled Naval Submarine Reactor Plants." *Federal Register* (December 6, 1984).

53 FR 12449. "Disposal of Hanford Defense High-Level, Transuranic and Tank Wastes, Hanford Site, Richland, Washington; Record of Decision (ROD)." *Federal Register* (April 14, 1988).

58 FR 12342. "States of Washington and Oregon: Denial of Petition for Rulemaking." *Federal Register* (March 4, 1993).

61 FR 10736. "Record of Decision: Management of Spent Nuclear Fuel from the K Basins at the Hanford Site, Richland, Washington." *Federal Register* (March 15, 1996). Online at: <http://www.gpoaccess.gov/fr/index.html>

61 FR 36352. "Record of Decision for Plutonium Finishing Plant Stabilization Final Environmental Impact Statement, Hanford Site, Richland, WA." *Federal Register* (July 10, 1996). Online at: <http://www.gpoaccess.gov/fr/index.html>

61 FR 41596. "National Environmental Policy Act Record of Decision for the Disposal of Decommissioned, Defueled Cruiser, Ohio Class, and Los Angeles Class Naval Reactor Plants." *Federal Register* (August 9, 1996). Online at: <http://www.gpoaccess.gov/fr/index.html>

62 FR 8693. "Record of Decision for the Tank Waste Remediation System, Hanford Site, Richland, WA." *Federal Register* (February 26, 1997). Online at: <http://www.gpoaccess.gov/fr/index.html>

62 FR 55615. "Notice of Intent to Prepare a Hanford Site Solid (Radioactive and Hazardous) Waste Program Environmental Impact Statement, Richland, WA." *Federal Register* (October 27, 1997). Online at: <http://www.gpoaccess.gov/fr/index.html>

62 FR 65254. "Hanford Site Solid (Radioactive and Hazardous) Waste Program Environmental Impact Statement Richland, Washington; Public Scoping Period Extension." *Federal Register* (December 11, 1997). Online at: <http://www.gpoaccess.gov/fr/index.html>

63 FR 3623. "Record of Decision for the Department of Energy's Waste Isolation Pilot Plant Disposal Phase." *Federal Register* (January 23, 1998). Online at: <http://www.gpoaccess.gov/fr/index.html>

63 FR 3629. "Record of Decision for the Department of Energy's Waste Management Program: Treatment and Storage of Transuranic Waste." *Federal Register* (January 23, 1998). Online at: <http://www.gpoaccess.gov/fr/index.html>

63 FR 41810. "Record of Decision for the Department of Energy's Waste Management Program: Treatment of Non-wastewater Hazardous Waste." *Federal Register* (August 5, 1998). Online at: <http://www.gpoaccess.gov/fr/index.html>

64 FR 46661. "Record of Decision for the Department of Energy's Waste Management Program: Storage of High-Level Radioactive Waste." *Federal Register* (August 26, 1999). Online at: <http://www.gpoaccess.gov/fr/index.html>

64 FR 61615. "Record of Decision: Hanford Comprehensive Land-Use Plan Environmental Impact Statement (HCP EIS)." *Federal Register* (November 12, 1999). Online at: <http://www.gpoaccess.gov/fr/index.html>

65 FR 10061. "Record of Decision for the Department of Energy's Waste Management Program: Treatment and Disposal of Low-Level Waste and Mixed Low-Level Waste; Amendment of the Record of Decision for the Nevada Test Site." *Federal Register* (February 25, 2000). Online at: <http://www.gpoaccess.gov/fr/index.html>

65 FR 82985. "Revision to the Record of Decision for the Department of Energy's Waste Management Program: Treatment and Storage of Transuranic Waste." *Federal Register* (December 29, 2000). Online at: <http://www.gpoaccess.gov/fr/index.html>

66 FR 38646. "Revision to the Record of Decision for the Department of Energy's Waste Management Program: Treatment and Storage of Transuranic Waste." *Federal Register* (July 25, 2001). Online at: <http://www.gpoaccess.gov/fr/index.html>

66 FR 64406. "Environmental Assessment and Finding of No Significant Impact for Transportation of Low-Level Radioactive Waste from the Oak Ridge Reservation to Off-Site Treatment or Disposal Facilities." *Federal Register* (December 13, 2001). Online at: <http://www.gpoaccess.gov/fr/index.html>

67 FR 36592. "Environmental Impact Statements; Notice of Availability." *Federal Register* (May 24, 2002). Online at: <http://www.gpoaccess.gov/fr/index.html>

67 FR 45104. "Supplemental Environmental Impact Statement for Disposal of Immobilized Low-Activity Wastes from Hanford Tank Waste Processing." *Federal Register* (July 8, 2002). Online at: <http://www.gpoaccess.gov/fr/index.html>

67 FR 56989. "Revision to the Record of Decision for the Department of Energy's Waste Management Program: Treatment and Storage of Transuranic Waste." *Federal Register* (September 6, 2002). Online at: <http://www.gpoaccess.gov/fr/index.html>

68 FR 1052. "Notice of Intent to Prepare an Environmental Impact Statement for Retrieval, Treatment, and Disposal of Tank Waste and Closure of Single-Shell Tanks at the Hanford Site, Richland, Washington." *Federal Register* (January 8, 2003). Online at: <http://www.gpoaccess.gov/fr/index.html>

68 FR 7110. "Notice of Revised Scope for the Hanford Site Solid (Radioactive and Hazardous) Waste Program Environmental Impact Statement, Richland, Washington." *Federal Register* (February 12, 2003). Online at: <http://www.gpoaccess.gov/fr/index.html>

68 FR 17801. "Environmental Impact Statements; Notice of Availability." *Federal Register* (April 11, 2003). Online at: <http://www.gpoaccess.gov/fr/index.html>

68 FR 28821. "Notice of Extension of Public Comment Period for the Revised Draft Hanford Site Solid (Radioactive and Hazardous) Waste Program Environmental Impact Statement, Richland, Washington." *Federal Register* (May 27, 2003). Online at: <http://www.gpoaccess.gov/fr/index.html>

68 FR 32486. "Environmental Impact Statements; Notice of Availability." *Federal Register* (May 30, 2003). Online at: <http://www.gpoaccess.gov/fr/index.html>

42 USC 2011 et seq. Atomic Energy Act (AEA) of 1954. Online at: <http://www4.law.cornell.edu>

42 USC 2021 et seq. Low-Level Radioactive Waste Policy Amendments Act of 1985. Online at: <http://www4.law.cornell.edu>

42 USC 4321 et seq. National Environmental Policy Act (NEPA) of 1969, as amended. Online at: <http://www4.law.cornell.edu>

42 USC 6901 et seq. Resource Conservation and Recovery Act (RCRA) of 1976. Online at: <http://www4.law.cornell.edu>

42 USC 9601 et seq. Comprehensive Environmental Response, Compensation, and Liability Act (CERCLA) of 1980. Online at: <http://www4.law.cornell.edu>

42 USC 10101 et seq. The Nuclear Waste Policy Act of 1982, as amended. Online at: <http://www4.law.cornell.edu>

Bernero, R. M. 1993. Letter from R. M. Bernero, Director of Office of Nuclear Material Safety and Safeguards, to J. Lytle at the U.S. Department of Energy. RE: "Staff assessment of new waste characterization data and current DOE plans for management of radioactive tank waste at Hanford." Dated March 1993, U.S. Nuclear Regulatory Commission, Washington, D.C.

City of Richland. 1998. *Environmental Impact Statement for Treatment of Low-Level Mixed Waste*. Prepared by Jacobs Engineering Group, Inc. for the Allied Technology Group Mixed Waste Facility. Richland, Washington.

Deffenbaugh, M. L. 2000. *The Remote-Handled Immobilization Low-Activity Waste Disposal Facility Environmental Permits and Approval Plan*. RPP-6270, Rev. 0, CH2M Hill Hanford Group, Richland, Washington.

DOE. 1987. *Final Environmental Impact Statement for Disposal of Hanford Defense High-Level, Transuranic, and Tank Wastes*. DOE/EIS-0113, U.S. Department of Energy, Washington D.C.

DOE. 1990. *Environmental Assessment for Battelle Columbus Laboratories Decommissioning Project (Finding of No Significant Impact, Decontamination and Decommissioning of Battelle Columbus Laboratories in Columbus and West Jefferson, Ohio)*. DOE/EA-0433, U.S. Department of Energy, Washington D.C.

DOE. 1992. *Environmental Assessment – Hanford Environmental Compliance Project, Hanford Site, Richland Washington*. DOE/EA-0383, U.S. Department of Energy, Richland Operations Office, Richland, Washington.

DOE. 1993. *Radiation Protection of the Public and the Environment*. DOE Order 5400.5, U.S. Department of Energy, Washington, D.C. Online at: <http://www.directives.doe.gov>

DOE. 1994. *Removal Actions under the Comprehensive Environmental Response, Compensation, and Liability Act (CERCLA)*. DOE/EH0435, U.S. Department of Energy, Office of Environmental Guidance, Washington D.C.

DOE. 1995a. *Environmental Assessment – Shutdown of the Fast Flux Test Facility, Hanford Site, Richland, Washington*. DOE/EA-0993, U.S. Department of Energy, Washington, D.C. Online at: <http://www.hanford.gov/docs/ea/ea0993/ea0993.pdf>

DOE. 1995b. *Solid Waste Retrieval Complex, Enhanced Radioactive and Mixed Waste Storage Facility, Infrastructure Upgrades, and Central Waste Support Complex, Hanford Site, Richland Washington - Environmental Assessment*. DOE/EA-0981, U.S. Department of Energy, Richland Operations Office, Richland, Washington.

DOE 1996a. *Final Programmatic Environmental Impact Statement for Stockpile Stewardship and Management, Summary*. DOE/EIS-0236-Summary, U.S. Department of Energy, Washington, D.C.

DOE. 1996b. *Management of Spent Nuclear Fuel from the K Basins at the Hanford Site, Richland, Washington*. DOE/EIS-0245, U.S. Department of Energy, Richland Operations Office, Richland, Washington.

DOE. 1996c. *Plutonium Finishing Plant Stabilization Final Environmental Impact Statement*. DOE/EIS-0244-F, U.S. Department of Energy, Richland Operations Office, Richland, Washington.

DOE. 1997a. *Environmental Assessment for the Relocation and Storage of Isotopic Heat Sources Hanford Site Richland, Washington*. DOE/EA-1211, U.S. Department of Energy, Richland Operations Office, Richland, Washington. Online at: <http://www.hanford.gov/docs/ea/ea1211/part-a.htm>

DOE. 1997b. *Environmental Assessment for Trench 33 Widening in 218-W-5 Low-Level Waste Burial Ground, Hanford Site, Richland, Washington*. DOE/EA-1203, U.S. Department of Energy, Richland Operations Office, Richland, Washington. Online at: <http://www.hanford.gov/netlib/ea.asp>

DOE. 1997c. *Final Waste Management Programmatic Environmental Impact Statement for Managing Treatment, Storage, and Disposal of Radioactive and Hazardous Waste*. DOE/EIS-0200-F, Vol. 1-5, U.S. Department of Energy, Washington, D.C.

DOE. 1997d. *Waste Isolation Pilot Plant Disposal Phase Final Supplemental Environmental Impact Statement*. DOE/EIS-0026-S-2, U.S. Department of Energy, Carlsbad Area Office, Carlsbad, New Mexico.

DOE. 1998. *Environmental Assessment – Non-Thermal Treatment of Hanford Site Low-Level Mixed Waste*. DOE/EA-1189, U.S. Department of Energy, Richland Operations Office, Richland, Washington. Online at: <http://www.hanford.gov/docs/ea/ea1189/index.html>

DOE. 1999a. *Environmental Assessment – Offsite Thermal Treatment of Low-Level Mixed Waste*. DOE/EA-1135, U.S. Department of Energy, Richland Operations Office, Richland, Washington. Online at: <http://www.hanford.gov/docs/ea/ea1135/FONSI.html>

DOE. 1999c→b. *Environmental Assessment for Widening Trench 36 of the 218-E-12B Low-Level Burial Ground, Hanford Site, Richland, Washington*. DOE/EA-1276, U.S. Department of Energy, Richland Operations Office, Richland, Washington. Online at: <http://www.hanford.gov/docs/ea/ea1276/ea1276.html>

DOE. 1999b→c. *Final Hanford Comprehensive Land-Use Plan Environmental Impact Statement*. DOE/EIS-0222-F, U.S. Department of Energy, Washington, D.C. Online at: <http://www.hanford.gov/eis/hraeis/maintoc.htm>

DOE. 2000. *Environmental Assessment - Disposition of Surplus Hanford Site Uranium, Hanford Site, Richland, Washington*. DOE/EA-1319, U.S. Department of Energy, Richland Operations Office, Richland, Washington. Online at: <http://www.hanford.gov/docs/ea/ea1319/ea1319.html>

DOE. 2001a. *(Draft) Environmental Assessment for Trench Construction and Operation in the 281-E-12B and 218-W-5 Low-Level Burial Grounds, Hanford Site, Richland, Washington*. DOE/EA-1373, U.S. Department of Energy, Richland Operations Office, Richland, Washington.

DOE. 2001b. *Environmental Assessment - K Basins Sludge Storage at 221-T Building, Hanford Site, Richland, Washington*. DOE/EA-1369, U.S. Department of Energy, Richland Operations Office, Richland, Washington. Online at: <http://www.hanford.gov/netlib/ea.asp>

DOE. 2001c. *Environmental Assessment - Use of Existing Borrow Areas, Hanford Site, Richland, Washington*. DOE/EA-1403, U.S. Department of Energy, Richland, Washington. Online at: <http://www.hanford.gov/netlib/ea.asp>

DOE. 2001d. *Environmental Assessment for the Offsite Transportation of Certain Low-level and Mixed Radioactive Waste from the Savannah River Site for Treatment and Disposal at Commercial and Government Facilities*. DOE/EA-1308, U.S. Department of Energy, Savannah River Operations Office, Aiken, South Carolina.

DOE. 2001e. *Long-Term Stewardship Study*. U.S. Department of Energy, Washington, D.C. Online at: <http://lts.apps.em.doe.gov/center/stewstudy.html>

DOE. 2001f. *Radioactive Waste Management Manual*. DOE Manual 435.1-1, U.S. Department of Energy, Washington, D.C. Online at: <http://www.directives.doe.gov>

DOE. 2001g. *Supplement Analysis for the Tank Waste Remediation System*. DOE/EIS-0189-SA3, U.S. Department of Energy, Richland Operations Office, Richland, Washington.

DOE. 2002a. *A Review of the Environmental Management Program Presented to the Assistant Secretary for Environmental Management by the Top-to-Bottom Review Team*. U.S. Department of Energy, Office of Environmental Management, Washington, D.C. Online at: <http://www.em.doe.gov/ttbr.pdf>

DOE. 2002b. *Draft Hanford Site Solid (Radioactive and Hazardous) Waste Program Environmental Impact Statement, Richland Washington*. DOE/EIS-0286D. U.S. Department of Energy, Richland Operations Office, Richland, Washington. Online at: [http://www.hanford.gov/eis/eis-0286D2/2002\\_Draft.cfm](http://www.hanford.gov/eis/eis-0286D2/2002_Draft.cfm)

DOE. 2002c. *Environmental Assessment - Transuranic Waste Retrieval from the 218-W-4B and 218-W-4C Low-Level Burial Grounds, Hanford Site, Richland, Washington*. DOE/EA-1405, U.S. Department of Energy, Richland Operations Office, Richland, Washington. Online at: <http://www.hanford.gov/docs/ea/ea1405/ea1405.pdf>

DOE. 2002d. *Final Environmental Impact Statement for a Geologic Repository for the Disposal of Spent Nuclear Fuel and High-Level Radioactive Waste at Yucca Mountain, Nye County, Nevada*. DOE/EIS-0250F, U.S. Department of Energy, Washington, D.C.

DOE. 2002e. *Report to Congress – The Cost of Waste Disposal: Life Cycle Cost Analysis of Disposal of Department of Energy Low-Level Radioactive Waste at Federal and Commercial Facilities*. U.S. Department of Energy, Office of Environmental Management, Washington, D.C. Online at: [http://www.envirocareutah.com/pages/pdf/Final\\_LLW\\_Report\\_7\\_08\\_02.pdf](http://www.envirocareutah.com/pages/pdf/Final_LLW_Report_7_08_02.pdf)

DOE. 2003a. *Draft Supplemental Programmatic Environmental Impact Statement on Stockpile Stewardship and Management for a Modern Pit Facility*. DOE/EIS-236-S2, U.S. Department of Energy, Washington, D.C. Online at: <http://tis.eh.doe.gov/nepa/docs/deis/deis0236S2/DEIS0236.htm>

DOE. 2003b. *Environmental Assessment – Deactivation of the Plutonium Finishing Plant, Hanford Site, Richland, Washington*. DOE/EA-1469, U.S. Department of Energy, Richland Operations Office, Richland, Washington. Online at: <http://www.hanford.gov/netlib/ea.asp>

DOE. 2003c. *Environmental Assessment for the Accelerated Tank Closure Demonstration Project*. DOE/EA-1462, U.S. Department of Energy, Office of River Protection, Richland, Washington. Online at: <http://www.hanford.gov/netlib/ea.asp>

DOE. 2003d. *Revised Draft Hanford Site Solid (Radioactive and Hazardous) Waste Program Environmental Impact Statement, Richland Washington*. DOE/EIS-0286D2, U.S. Department of Energy, Richland Operations Office, Richland, Washington. Online at: <http://www.hanford.gov/eis/eis-0286D2>

DOE. 2003e. *West Valley Demonstration Project Waste Management Environmental Impact Statement*. DOE/EIS-0337F, U.S. Department of Energy, West Valley Area Office, West Valley, New York. Online at: <http://tis.eh.doe.gov/nepa/eis/eis0337/index.html>

DOE-RL. 2002a. *Cleanup, Constraints, and Challenges (C3T) Team Status Interim Report*. DOE/RL-2002-65, Rev. 0, U.S. Department of Energy, Richland Operations Office, Richland, Washington. Online at: <http://www.hanford.gov/docs/rl-2002-65/rl-2002-65.pdf>

DOE-RL. 2002b. *Performance Management Plan for the Accelerated Cleanup of the Hanford Site*. DOE/RL-2002-47, Rev. D, U.S. Department of Energy, Richland Operations Office and the Office of River Protection, Richland, Washington. Online at: <http://www.hanford.gov/docs/rl-2002-47/rl-2002-47.pdf>

DOE and Ecology. 1996. *Tank Waste Remediation System, Hanford Site, Richland, Washington, Final Environmental Impact Statement*. DOE/EIS-0189, U.S. Department of Energy, Richland Operations Office, Richland, Washington and Washington State Department of Ecology, Olympia, Washington.

DOE, EPA, and Ecology. 1995. "Record of Decision. U.S. DOE Hanford Environmental Restoration Disposal Facility, Hanford Site, Benton County, Washington." U.S. Department of Energy, Richland, Washington, U.S. Environmental Protection Agency, Seattle, Washington, and Washington State Department of Ecology, Olympia, Washington. Online at: <http://www2.hanford.gov/arpir/common/findpage.cfm?DType=ArPir&AKey=D196041064&pages=103>

DOE, EPA, and Ecology. 1997. "U.S. Department of Energy Environmental Restoration Disposal Facility, Hanford Site - 200 Area, Benton County, Washington, Amended Record of Decision, Decision Summary and Responsiveness Summary." U.S. Department of Energy, Richland, Washington, U.S. Environmental Protection Agency, Seattle, Washington, and Washington State Department of Ecology, Olympia, Washington. Online at: <http://www2.hanford.gov/arpir/common/findpage.cfm?DType=ArPir&AKey=D197286764&pages=26>

DOE, EPA, and Ecology. 1999. "U.S. Department of Energy Environmental Restoration Disposal Facility, Hanford Site - 200 Area, Benton County, Washington, Amended Record of Decision, Decision Summary and Responsiveness Summary." U.S. Department of Energy, Richland, Washington, U.S. Environmental Protection Agency, Seattle, Washington, and Washington State Department of Ecology, Olympia, Washington. Online at: <http://www2.hanford.gov/arpir/common/findpage.cfm?DType=ArPir&AKey=D199122784&pages=64>

Ecology. 2003. "Administrative Order Against the United States Department of Energy, Richland Operations," Order No. 03NWPKW-5494, April 30, 2003, Washington State Department of Ecology, Olympia Washington. Online at: <http://www.ecy.wa.gov/programs/nwp/pdf/dd403.pdf>

Ecology, EPA, and DOE. 1989. *Hanford Federal Facility Agreement and Consent Order*. 89-10 (As Amended). Washington State Department of Ecology, U.S. Environmental Protection Agency, U.S. Department of Energy, Richland, Washington. Online at: <http://www.hanford.gov/tpa/tpahome.htm>

Envirocare of Utah, Inc. 2000a. *Envirocare Begins 5<sup>th</sup> Year of Service on K-25 Pond Project*. (April 2000). Online at: [http://www.envirocareutah.com/pages/ecnews/ec\\_begins\\_5th.html](http://www.envirocareutah.com/pages/ecnews/ec_begins_5th.html)

Envirocare of Utah, Inc. 2000b. *Envirocare Receives First Shipment from DOE Savannah River Site*. (October 2000). Online at: [http://www.envirocareutah.com/pages/ecnews/waste\\_shipment\\_sr.html](http://www.envirocareutah.com/pages/ecnews/waste_shipment_sr.html)

Envirocare of Utah, Inc. 2000c. *Envirocare Receives High Marks from Department of Energy*. (March 2000). Online at: [http://www.envirocareutah.com/pages/ecnews/ec\\_receives.html](http://www.envirocareutah.com/pages/ecnews/ec_receives.html)

EPA. 2001. "Declaration of the Record of Decision: U.S. Department of Energy 300 Area 300-FF-2 Operable Unit, Hanford Site, Benton County, Washington." EPA ID# WA 2890090077, U.S. Environmental Protection Agency, Region 10, Seattle Washington. Online at: <http://yosemite.epa.gov/R10/CLEANUP.NSF/7780249be8f251538825650f0070bd8b/81e02b8ec1438a9888256592005854f5?OpenDocument>

ERDA. 1975. *Final Environmental Statement, Waste Management Operations, Hanford Reservation, Richland, Washington*. ERDA-1538, U.S. Energy Research and Development Administration, Washington, D.C.

FH. 2003. *Hanford Site Solid Waste Acceptance Criteria*. HNF-EP-0063, Rev. 9, Fluor Hanford, Inc., Richland, Washington. Online at: <http://www.hanford.gov/wastemgt/wac/acceptcriteria.cfm>

Kincaid, C. T., J. W. Shade, G. A. Whyatt, M. G. Piepho, K. Rhoads, J. A. Voogd, J. H. Westsik, Jr., M. D. Freshley, K. A. Blanchard, G. B. Lauzon. 1995. *Performance Assessment of Grouted Double-Shell Tank Waste Disposal at Hanford*. WHC-SD-WM-EE-004, Rev. 1, Volumes 1 & 2, Westinghouse Hanford Company, Richland, Washington.

Navy. 1984. *Final Environmental Impact Statement on the Decommissioned Defueled Naval Submarine Reactor Plants*. U.S. Department of the Navy, Washington, D.C.

Navy. 1996. *Final Environmental Impact Statement on the Decommissioned Defueled Ohio and Los Angeles Class Naval Reactor Plants*. DOE/EIS-0259. U.S. Department of the Navy, Washington, D.C.



NRC. 1997. *Classification of Hanford Low-Activity Tank Waste Fraction as Incidental*. Letter from L. Joseph Callan, Executive Director of Operations to the U.S. Nuclear Regulatory Commissioners. SECY-97-083, U.S. Nuclear Regulatory Commission, Washington D.C. Online at:  
<http://www.nrc.gov/reading-rm/doc-collections/commission/secys/1997/secy1997-083/1997-083scy.html>

United States of America and Ecology. 2003. "Settlement Agreement," October 23, 2003, United States of America and the Washington State Department of Ecology, Olympia Washington. Online at:  
<http://www.ecy.wa.gov/programs/nwp/pdf/settlement.pdf>.

WAC 173-303. "Dangerous Waste Regulations." Washington Administrative Code. Olympia, Washington. Online at:  
<http://www.leg.wa.gov/wac/index.cfm?fuseaction=chapterdigest&chapter=173-303>

WDOH and Ecology. 2000. *Draft Environmental Impact Statement. Commercial Low-Level Radioactive Waste Disposal Site, Richland, Washington*. Washington State Department of Health and Washington State Department of Ecology, Olympia, Washington. Online at:  
<http://www.ecy.wa.gov/pubs/0005010.pdf>

## 2.0 HSW EIS Waste Streams and Waste Management Facilities

This section describes:

- the four waste types evaluated in this EIS: low-level waste (LLW), mixed low-level waste (MLLW), transuranic (TRU) waste, and Waste Treatment Plant (WTP) waste<sup>(a)</sup>
- the specific waste streams within the four waste types
- the waste management facilities that are currently being used
- the proposed new or modified facilities that are being evaluated in the various HSW EIS alternative groups.

Additional information on Hanford waste streams and facilities is contained in Appendixes B, C, and D and the Technical Information Document (FH 2004).

### 2.1 Solid Waste Types and Waste Streams Related to the Proposed Action

Historically, solid LLW was disposed of in shallow-land disposal units. In 1970, a U.S. Department of Energy predecessor agency, the U.S. Atomic Energy Commission (AEC), determined that waste containing TRU radionuclides would be managed separately from LLW and stored until an appropriate disposal facility was available. Beginning at that time, the suspect TRU waste was emplaced in a manner that it could be retrieved (hence, it is sometimes called “retrievably stored”).

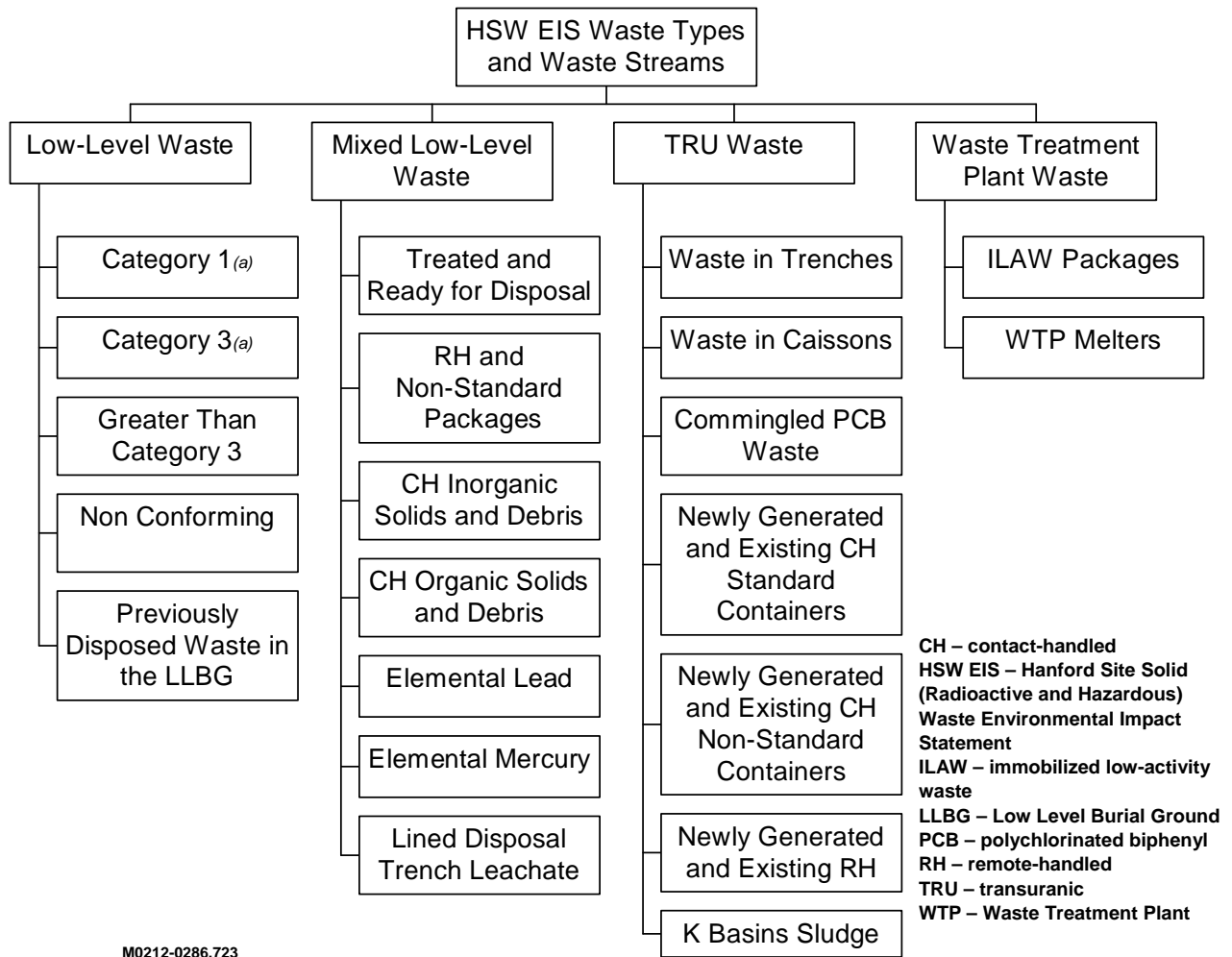
In 1987, DOE directed that radioactive waste containing chemically hazardous components, as identified under the Resource Conservation and Recovery Act (RCRA) of 1976 (42 USC 6901 et seq.), be separated and managed separately from LLW (10 CFR 962.3). This waste, referred to as MLLW, is placed into above ground storage facilities at Hanford until it can be treated and disposed of.

Treatment of Hanford tank waste at the WTP as part of the River Protection Project will result in several waste streams. Of those waste streams, ILAW and melters are being considered as a separate waste type in this EIS because of their unique management requirements. Other routine wastes that may be generated during WTP operations are included in the forecast LLW, MLLW, and TRU wastes.

Each of the four waste types has been further divided into waste streams for analysis in this HSW EIS. For the purposes of this EIS, a waste stream is defined as waste with physical and chemical characteristics that would generally require the same management approach (i.e., using the same storage, treatment, and disposal capabilities). The waste types and waste streams considered within this EIS are shown in Figure 2.1. Brief descriptions of the waste streams are contained in subsequent sections. Information on the volume of waste associated with each stream is provided in Section 3.3.

---

(a) The WTP wastes (immobilized low-activity waste and melters) are assumed to be MLLW but are considered a separate waste type for the discussions in this EIS.



(a) Category 2 LLW is no longer considered a separate waste stream. See Section 2.1.1.2 for explanation.

**Figure 2.1.** Waste Types and Waste Streams Considered in the HSW EIS

Radioactive waste may be contact-handled (CH) or remote-handled (RH) waste. CH waste has a dose rate less than 200 millirem/hr as measured with the detector in contact with the container and can be handled without shielding. The RH waste classification applies to containers with a contact dose rate greater than 200 millirem/hr. RH waste requires the use of additional shielding and special facilities to protect workers.

### 2.1.1 LLW Streams

Low-level waste may be generated during the handling of radioactive materials, which results in the contamination of items and materials. Because many different activities are conducted using different types of radioactive materials and levels of radioactivity, there is a wide variation in the chemical and physical characteristics of waste and levels of contamination. Most of the LLW currently in the Low

Level Burial Grounds (LLBGs) was generated by analytical laboratories, reactors, separation facilities, plutonium processing facilities, and waste management activities. At Hanford, solid LLW includes protective clothing, plastic sheeting, gloves, paper, wood, analytical waste, contaminated equipment, contaminated soil, nuclear reactor hardware, nuclear fuel hardware, and spent deionizer resin from purification of water in radioactive material storage basins. In the foreseeable future, analytical laboratories, research operations, facility deactivation projects, waste management activities, and other onsite and offsite activities would likely continue to generate LLW.

Typical containers used for burial of LLW include 208-L (55-gal) metal drums and boxes nominally 1.2 m by 1.2 m by 2.4 m (4 ft by 4 ft by 8 ft) in size. Other boxes are made in various sizes to accommodate specific waste items. Cardboard, wood, and fiber-reinforced plastic boxes have also been used. Large items or equipment may be wrapped in plastic. However, some bulk waste (that is, soil or rubble) is disposed of without containers.

Both onsite and offsite generators of LLW are required to meet specific criteria for their wastes to be accepted for disposal at Hanford. Those requirements are defined in the *Hanford Site Solid Waste Acceptance Criteria* (HSSWAC) (FH 2003) and include requirements on the waste package, descriptions of the contents of the waste package, the radionuclide content, physical size, and chemical composition. To verify that generators conform with the HSSWAC, a random sample of incoming CH waste is periodically selected for verification at the Waste Receiving and Processing Facility (WRAP), the T Plant Complex, or other appropriate location. Verification of RH waste is typically conducted at the generating facility. Discovery of non-conforming waste can result in rejection of the waste with its return to the generator, or the need for removal or treatment of prohibited items at the generator's expense. Most LLW is only stored for short periods of time awaiting verification or disposal.

The HSSWAC also define LLW categories summarized below by radionuclide activity level. The categories are based on site-specific performance assessments that were conducted in conformance with DOE Manual 435.1-1 (DOE 2001b). The HSSWAC should be consulted for technical details defining Category 1 (Cat 1), Category 3 (Cat 3), and greater than Category 3 (GTC3) wastes. Cat 1 wastes have lower concentrations of radionuclides than Cat 3 wastes. All Cat 1 and Cat 3 wastes that meet the HSSWAC requirements can be disposed of in the LLBGs. GTC3 wastes have even higher concentrations of radionuclides than Cat 3 wastes and require a specific analysis to determine whether they can be disposed of in the LLBGs. Cat 3 and GTC3 LLW are subject to additional disposal requirements because they contain higher concentrations of radionuclides.

The U.S. Nuclear Regulatory Commission (NRC) in 10 CFR 61.55 defines four classes of LLW (A, B, C, and greater than Class C). The NRC requirements apply to all commercial LLW disposal sites. The HSSWAC only apply to Hanford and are adjusted for specific Hanford conditions. Therefore the radionuclide concentrations specified for each NRC class are not necessarily the same as those defined in the HSSWAC for LLW categories.

#### **2.1.1.1 Low-Level Waste – Category 1**

Cat 1 LLW represents the largest volume of waste expected at the Hanford Site. It has the lowest concentrations of radioactivity and can be directly placed into the LLBG trenches without treatment and in some cases without additional packaging. Cat 1 LLW can be either CH or RH waste.

### **2.1.1.2 Low-Level Waste – Category 3**

In the original development of the waste categories, Category 2 LLW was defined. However, this category resulted in a small volume of waste and the previous Category 2 material is now managed as Cat 3 LLW. Cat 3 LLW is defined as having radionuclide concentrations greater than limits specified in the HSSWAC for Cat 1 LLW, but lower than maximum concentration limits defined for Cat 3 LLW. Cat 3 LLW is similar to Cat 1 LLW except that it has higher concentrations of certain radionuclides, and requires greater confinement for burial in the LLBGs (FH 2003). Cat 3 LLW may also be CH or RH waste. Greater confinement in the LLBGs has typically been provided either by packaging the wastes in high-integrity containers (HICs) or by in-trench grouting prior to burial (Section 2.2.3). Typical sources of the Cat 3 LLW are operation or cleanout of hot cells and canyon facilities, removal of HLW storage tank equipment, examination of irradiated reactor fuel assembly components, and other operations that handle higher activity items.

### **2.1.1.3 Low-Level Waste – Greater Than Category 3**

GTC3 LLW exceeds the radionuclide concentration limits for Cat 3 LLW. GTC3 LLW requires a specific evaluation to demonstrate that requirements of the LLBG performance assessments would be met before it can be disposed of at Hanford. GTC3 LLW can generally be disposed of in the same manner as Cat 3 LLW in HICs or by in-trench grouting. The sources of GTC3 LLW are similar to Cat 3 LLW. No GTC3 LLW is currently forecast; however, a small volume of this waste is analyzed in this EIS to address future contingencies.

### **2.1.1.4 Low-Level Waste – Non-Conforming**

Non-conforming LLW is waste that does not meet the current HSSWAC for burial and cannot readily be treated to meet those requirements. Non-conforming waste needs to be processed so it conforms with the HSSWAC.

### **2.1.1.5 Waste Previously Disposed of in the Low Level Burial Grounds**

This waste stream includes all waste that has been disposed of in the LLBGs described in Appendix D except for the retrievably stored TRU waste. This waste is included in the EIS analysis of LLBG closure, long-term, and cumulative impacts.

## **2.1.2 Mixed Low-Level Waste Streams**

Regulatory information for mixed wastes can be found in Sections 6.3 and 6.4. Both onsite and offsite MLLW must also meet requirements of HSSWAC. Some waste is subject to Washington State RCRA program (regulated under the Dangerous Waste Regulations, WAC 173-303) with delegated authority for implementation of the Federal RCRA program and independent state statutory authority pursuant to the Washington State Hazardous Waste Management Act (RCW 70.105). In addition, Hanford has some LLW that also contains polychlorinated biphenyls (PCBs), which are regulated under the Toxic Substances Control Act (TSCA) of 1976 (15 USC 2601 et seq.). TSCA wastes are being

managed similar to mixed wastes and are included in MLLW inventories and projections. In addition, wastes that are not considered hazardous by the U.S. Environmental Protection Agency (EPA) may be managed as MLLW because they are considered toxic, persistent, or corrosive by state regulations. MLLW was generated by activities similar to those that created LLW, and the two types of waste were not differentiated until 1987. Beginning in 1987, DOE determined that radioactive wastes mixed with hazardous wastes would be designated under RCRA, and would be managed in accordance with RCRA (10 CFR 962.3). Accordingly, DOE has acquired regulatory-compliant waste management storage facilities through building new, or modifying existing Hanford facilities.

Hanford's MLLW was generated from operations, maintenance, and cleanout of reactors, chemical separation facilities, high-level waste (HLW) tanks, and laboratories. MLLW contains the same type of materials as LLW. It typically consists of materials such as sludges, ashes, resins, paint waste, soils, lead shielding, contaminated equipment, protective clothing, plastic sheeting, gloves, paper, wood, analytical waste, and contaminated soil. Hazardous components may include lead and other heavy metals, solvents, paints, oils, other hazardous organic materials, or components that exhibit characteristics of ignitability, corrosivity, toxicity, or reactivity as defined by the dangerous waste regulations.

Extended storage of MLLW is restricted to permitted engineered facilities, such as the CWC. However, pursuant to the applicable regulations, non-permitted facilities may accumulate newly generated MLLW for periods up to 90 days before transferring them to a permitted storage or treatment facility (WAC 173-303-200). Regulatory compliant treatment (generally immobilization or destruction of the hazardous component) is required before most of the MLLW can be sent to a permitted land disposal facility. In some cases, MLLW will already be treated and regulatory compliant when it is received and can be sent directly to the disposal facility. In other cases, the waste will require treatment prior to disposal. Brief descriptions of potential mixed waste treatment technologies are included in the Technical Information Document (FH 2004). The current approach to treatment of MLLW at Hanford uses a combination of onsite and commercial treatment facilities. The Hanford Site currently has limited capacity for MLLW treatment at facilities such as WRAP and the T Plant Complex. Two contracts were placed with a commercial vendor to begin treating limited quantities of CH MLLW in the year 2000. The contracts were intended to serve as a technical demonstration for future commercial treatment of the majority of Hanford's MLLW (see Section 2.2.2.2). After the waste has been treated and meets the regulatory requirements, it can be disposed of in a regulatory-compliant disposal facility. Hanford currently has two MLLW disposal trenches located in the 200 West Area that are operating under interim status. As with LLW, MLLW may be categorized according to radionuclide content as either Cat 1 or Cat 3 MLLW, with disposal requirements described in the HSSWAC.

#### **2.1.2.1 Mixed Low-Level Waste – Treated and Ready for Disposal**

This waste stream consists of MLLW that has been treated to meet the applicable RCRA and state requirements for land disposal. The River Protection Project (RPP) is expected to be the primary Hanford generator of MLLW. The RPP waste includes long-length equipment (see Figure 2.2) from Hanford tank retrieval operations, which would be macroencapsulated. MLLW received from offsite generators is assumed to arrive in a regulatory-compliant form and ready for disposal.



M0212-0286.8  
HSW EIS 12-10-02

**Figure 2.2.** Long-Length Tank Equipment

### **2.1.2.2 Mixed Low-Level Waste – RH and Non-Standard Packages**

Existing and forecast quantities of RH MLLW cannot easily be treated under the existing MLLW treatment contracts or at onsite facilities. This waste has physical and chemical characteristics similar to other MLLW, but requires a shielded facility and special equipment for remote handling. In the future, some non-standard packages of CH waste may also be received for which there is no treatment facility. This waste would remain in storage until treatment facilities are available.

### 2.1.2.3 MLLW – CH Inorganic Solids and Debris

Inorganic solid waste may include substances such as sludges, paints, and dried inorganic chemicals. Debris waste must meet criteria defined in state regulations (WAC 173-303-040). Inorganic debris wastes often contain metal, ceramic, and concrete items and may result from removal of failed or obsolete equipment or from disposal of items used during process operations. They may also result from cleanout or decommissioning of inactive facilities. These wastes generally require treatment by stabilization, or macroencapsulation before disposal.

#### ***Non-Thermal Treatments***

such as stabilization and macroencapsulation are used to immobilize radionuclides and hazardous inorganic components using cement or plastics either as a jacket of material around the waste or as a matrix incorporating the waste.

### 2.1.2.4 MLLW – CH Organic Solids and Debris

Organic solid waste may include substances such as resins, organic absorbents, and activated carbon. Organic debris wastes meet the regulatory requirements for debris wastes (WAC 173-303-040) and have a greater than 10 percent organic/carbonaceous content. Typical wastes include paper, wood, or plastic. These wastes are included as organic/carbonaceous waste in WAC 173-303-140, which requires that they be thermally treated if capacity is available. There are no existing or planned Hanford facilities with thermal treatment capability for solid waste. Until thermal treatment is available within 1610 km (1000 mi) (WAC 173-303-140), DOE has been authorized by the Washington State Department of Ecology (Ecology) to treat organic debris waste by macroencapsulation.

#### ***Thermal Treatments***

are used to destroy organic constituents within the waste. Thermal treatment uses high temperatures and can include processes such as plasma arcs, incinerators, or vitrification.

### 2.1.2.5 MLLW – Elemental Lead

Lead metal has been used at Hanford and other DOE sites for radiation shielding and in applications where its high density is of benefit. Most of the lead waste has surface contamination and some of the lead is radioactive from neutron activation. Some lead must be treated as mixed waste by macroencapsulation, or other approved technology, before disposal.

### 2.1.2.6 MLLW – Elemental Mercury

Elemental mercury is a contaminant for several different types of waste. Waste can contain liquid mercury from various items (that is, light bulbs, switches, thermometers, and chemical process equipment). Mercury can be removed from bulk waste by thermal desorption and then solidified by amalgamation.

#### ***Thermal Desorption***

heats the waste to temperatures sufficient to vaporize mercury, which is subsequently condensed in a separate vessel.

#### ***Amalgamation***

solidification of mercury by mixing it with sulfur or other material to form a stable solid.



Limited amalgamation treatment capacity for mercury waste is available at existing Hanford facilities, but additional capability for treatment of the remaining waste is needed.

### **2.1.2.7 MLLW – Lined Disposal Trench Leachate**

This waste stream is generated from operation of lined disposal trenches. It is mostly rainwater or melted snow that is trapped by the collection systems in the lined disposal trenches. It is a liquid waste and is managed differently from the other wastes discussed in this EIS. The liquid waste is currently removed from the lined trenches and trucked to the Effluent Treatment Facility (ETF) where it is treated along with other liquid mixed wastes. Solid waste resulting from the treatment is included in the solid waste streams discussed in previous sections.

### **2.1.3 TRU Waste Streams**

The production of TRU materials, primarily plutonium, was the primary defense mission of the Hanford Site. Most of the Hanford TRU waste was produced in plutonium handling facilities for management of weapons materials or from research on plutonium fuels.

Prior to 1970, TRU waste had not been designated as a separate waste type. In 1970, the Atomic Energy Commission (AEC) determined that waste containing transuranic elements might be associated with increased hazards and should be disposed of in facilities that provide a greater level of confinement than the type of shallow-land burial typically used for disposal of LLW.

The AEC set a minimum concentration level of TRU isotopes at 10 nanocuries per gram of waste. At that time field instrumentation was not available to measure concentrations at that level. Therefore, waste associated with the handling of plutonium was considered to be suspect TRU waste and was placed in a retrievable configuration. The definition of TRU waste was changed to 100 nanocuries/gram in 1984. Once it is determined that the concentration of transuranic elements is below 100 nanocuries/gram, the waste would no longer be managed as suspect TRU waste. For purposes of analysis in this EIS, it was assumed to be managed as LLW. An evaluation of the CH waste placed into retrievable storage estimated that 50 percent of the drums currently managed as TRU waste, would be reclassified as LLW (Anderson et al. 1990).

TRU waste has been stored in several different ways at Hanford. TRU waste was initially placed into retrievable storage in the LLBGs, either with or without a soil cover. After 1985 most TRU waste was no longer placed in trenches, but was stored in an existing facility near the T Plant Complex that had been retrofitted for TRU waste storage. This building was known as the Transuranic Storage and Assay Facility (TRUSAF). Waste storage in that facility was discontinued in 1998 and its inventory, along with most newly generated TRU waste, is now stored in the CWC. TRU waste is also stored at T Plant, in the LLBGs, or at other onsite locations, according to handling and storage requirements for particular waste streams. Newly received TRU waste that contains hazardous materials as defined by RCRA or state regulation is stored in facilities permitted for mixed waste, such as CWC and T Plant. Storage of RH and CH TRU waste would continue until the waste is shipped to WIPP for disposal. Assumptions used in this

EIS regarding the processing and shipment of TRU waste to WIPP are located in Appendix B, Table B.3. The Hanford Performance Management Plan (HPMP) discusses the acceleration of these activities (see Appendix N, Table N.1).

TRU waste disposal began in 1999 with the opening of DOE's Waste Isolation Pilot Plant (WIPP) in New Mexico. The Hanford Site began shipping waste to WIPP in July 2000. Wastes to be shipped to WIPP must be certified to meet the WIPP Waste Acceptance Criteria (DOE-WIPP 2002). WRAP was designed and built at Hanford to perform certification of most CH TRU waste for disposal at WIPP, along with several other functions. Currently, CH TRU drums are being removed from CWC, certified at the WRAP, and shipped to WIPP. TRU waste drums are placed in shipping casks known as Transuranic Package Transporter-II (TRUPACT-II) and are transported by truck to the WIPP (see <http://www.emnrd.state.nm.us/wipp/trubig.htm> for description).

Some TRU waste also contains hazardous components (mixed TRU waste) and would be managed under applicable RCRA, TSCA, or other state regulations. Contact-handled mixed TRU waste is currently acceptable at WIPP. DOE's hazardous waste permit for WIPP, issued by the State of New Mexico Environment Department in 1999, authorizes the disposal of CH mixed TRU waste. DOE expects to have the capability to transport, receive, and dispose of RH wastes at WIPP by 2006 (DOE-NTP 2002).

#### **2.1.3.1 TRU Waste – Waste from Trenches**

From 1970 to 1985, the primary method for storage of TRU wastes involved placing drums or boxes of waste on asphalt pads constructed in the bottom of the trenches and covering the drums with wood, plastic, and a layer of soil (see Section 2.2.1.2). The TRU waste was expected to remain there for less than 20 years. Corrosion of the packaging has continued since they were buried and preliminary inspection of some older containers has confirmed deterioration in their condition. However, observations and monitoring of the area around the drums within the trenches have not detected the release of any alpha emitters, such as plutonium.

DOE previously evaluated the impacts of retrieving this TRU waste (DOE 1987, 2002a) for disposal at WIPP. A description of the activities involved and the impacts analyzed in these previous documents is presented in Sections 1.5.2. The processing of TRU waste at Hanford is evaluated in this HSW EIS in Section 5. The CH drums can be processed, repackaged, and certified at WRAP. However, the capability to process, certify, and ship non-standard containers or RH wastes to WIPP is not available at the Hanford Site, at other DOE sites, or at commercial facilities. These wastes would be placed in CWC until they can be processed. Processing of these wastes would require development of new capabilities. Both the new facilities and the processing operations are evaluated in this EIS.

#### **2.1.3.2 TRU Waste – Waste from Caissons**

Beginning in 1970 through 1988, higher-activity TRU waste was placed in four caissons for retrievable storage. These TRU waste caissons are located in Burial Ground 218-W-4B as shown in Appendix D. Most of the waste in the TRU caissons originated from laboratory activities in hot cells in the 300 Area

facilities. About 5500 containers were sent to these caissons. Of those, about 97 percent were 3.8-L (1-gal) cans containing residue from the examination of nuclear fuels and irradiated structural materials. Some of the individual containers had measured radiation levels in excess of 1500 R/hr at the time of placement. Other wastes included small-scale process equipment used for radionuclide separations operations. For additional information about the caissons, see Section 2.2.1.3.

DOE previously evaluated the impacts of retrieving this TRU waste (DOE 1987; DOE 2002a) for disposal at WIPP. A description of the activities involved and the impacts analyzed in these previous documents is presented in Section 1.5.2. Waste in the caissons is assumed to be RH TRU waste, and the impacts of processing it at T Plant or a new Hanford facility are evaluated in Section 5.

### **2.1.3.3 TRU Waste – Commingled PCB Waste**

A small amount of TRU waste has sufficient concentrations of PCBs to make it subject to TSCA requirements. Most of the material is debris commingled with a small amount of PCBs, although some drums contain liquids with higher PCB content. Sludge from the K Basins is also TSCA regulated due to its PCB content, but is discussed separately in Section 2.1.3.7. At this time TSCA regulations require treatment of PCB wastes by incineration or other approved technology (40 CFR 761.60). TRU waste commingled with PCBs has not yet been approved for disposal at WIPP. However, DOE has submitted a permit application to allow disposal of this waste at WIPP. If WIPP is granted a permit to dispose of PCB-commingled waste, treatment may not be necessary for the debris materials. Liquid waste containing PCBs may still require thermal treatment or an approved alternative treatment before it could be accepted at WIPP. No capabilities currently exist on the Hanford Site to treat PCB waste. The wastes are expected to remain in storage in CWC until a treatment facility is available or until WIPP can accept such materials.

### **2.1.3.4 TRU Waste – Newly Generated and Existing CH Standard Containers**

This waste stream includes CH TRU waste in standard containers stored in the CWC and future TRU waste that would be received in standard containers. This waste stream also includes the CH TRU waste that will be retrieved from the 618-10 and 618-11 Burial Grounds. The retrieved waste will be placed into standard containers including 208-L (55-gal) and 322-L (85-gal) drums and standard waste boxes (SWBs). The SWB is a metal box 181 cm (71 in) long, 94 cm (37 in) high, and 138 cm (54.5 in) wide that has been designed as a Type A shipping container for use in the TRUPACT-II shipping container. The waste would be inspected and certified at WRAP and would ultimately be shipped to the WIPP for disposal.

### **2.1.3.5 TRU Waste – Newly Generated and Existing CH Non-Standard Containers**

This TRU waste is contained in non-standard boxes or containers that are not compatible with a TRUPACT-II shipping container and that cannot be handled within WRAP. Much of this waste is old equipment or gloveboxes that were removed from processing and laboratory facilities. Processing of this

waste would likely include size reduction and repackaging. The Hanford Site does not currently have a facility where these wastes can be prepared for shipment to WIPP. Until they can be processed they will remain in the CWC.

#### **2.1.3.6 TRU Waste – Newly Generated and Existing RH Containers**

This TRU waste stream consists of existing and newly generated RH TRU waste, including a small quantity of waste that may be generated during retrieval from the 618-10 and 618-11 Burial Grounds. RH TRU waste would be shielded for storage in the CWC (see Section 2.2.1.1). In some cases, non-mixed RH TRU waste would be stored in concrete vaults in the LLBGs. The Hanford Site does not currently have a facility where RH TRU waste can be prepared for shipment to WIPP, nor are the WIPP waste acceptance criteria or shipping system in place. The RH TRU waste would be accepted at WIPP in accordance with the National TRU Waste Management Plan (DOE-NTP 2002).

#### **2.1.3.7 TRU Waste – K Basin Sludge**

This sludge is a combination of corrosion debris from stored fuel elements and their containers, dust, and other materials that have accumulated in the 100 K Area Basins over many years of use. Because of the plutonium, fission product and activation product concentrations in the sludges, they have been determined to be RH TRU waste. In addition, the sludge is TSCA-regulated due to its PCB content. DOE plans to containerize the waste as it is removed from the basins and then transport it to the T Plant Complex for storage (DOE 2001a) until a facility is available to process the waste and prepare it for shipment to WIPP.

### **2.1.4 Waste Treatment Plant Wastes**

The Waste Treatment Plant (WTP) will receive and process the retrieved Hanford tank waste. The retrieved tank waste will undergo a separations process that splits the waste stream into a smaller volume high-level waste (HLW) stream and a larger volume low-activity waste (LAW) stream. The HLW stream will be vitrified and placed into canisters that will be temporarily stored onsite in the Canister Storage Building and eventually sent offsite to the national geologic repository currently planned for Yucca Mountain. The processing of the wastes including their vitrification and the management of the HLW was previously evaluated in the TWRS EIS (DOE and Ecology 1996) and is not included in the scope of this EIS. For purposes of analysis in this EIS, the LAW stream also is assumed to be vitrified in the WTP. After vitrification, the LAW stream is called immobilized low-activity waste (ILAW). The melters used in the WTP for vitrification of Hanford tank wastes would occasionally need to be replaced. These melters become their own waste stream called “WTP melters.” Because the TWRS EIS has evaluated the processing of the glass, the HSW EIS addresses only the disposal of the ILAW and the WTP melters. It should be noted that the WTP will produce other LLW, MLLW, and TRU wastes that are included in the waste streams discussed in the previous sections.

#### **2.1.4.1 Immobilized Low-Activity Waste Packages**

During processing in the WTP, the molten ILAW can be directly poured into stainless steel canisters to produce a monolithic glass waste form, or it can be poured into water to produce waste in the form of granular glass particles similar to coarse sand, called cullet. The canisters for the monolithic glass waste form would be approximately 2.3 m (7.5 ft) in height and 1.22 m (4.0 ft) in diameter and would weigh up to 10,000 kg (22,000 lb) each when filled. An estimated 81,000 canisters would be filled using the monolithic pour compared to 140,000 canisters being filled with cullet. Dose rates from the cylinders are high enough (~500 mR/hr on contact) that remote handling would be required. The principal components in ILAW glass are silica, calcium oxide, and sodium oxide, making it a soda-lime silicate glass. Other waste forms are being considered for ILAW and are being analyzed in the Tank Closure EIS (68 FR 1052).

#### **2.1.4.2 WTP Melters**

The vitrification of Hanford tank wastes would use large melters comprised of metal structural components and ceramic refractories to contain the molten glass. With use, the refractories are slowly consumed and some metal components can become corroded. For this EIS, it was assumed the WTP melters would periodically be replaced with new units, and only the melters that meet HSSWAC would be managed and disposed of onsite in accordance with applicable requirements for RH MLLW. Packages containing the melters can have dimensions of 4.6 to 7.6 m (15 to 25 ft) in length, height, and width; can weigh 545,000 kg (600 tons); and would require special handling.

## **2.2 Hanford Waste Storage, Treatment, and Disposal Facilities, and Transportation Capabilities Related to the Proposed Action**

This section briefly describes existing and proposed facilities for the management of Hanford solid waste. The facilities provide storage, treatment, or disposal functions and are grouped by their primary function in the following discussion (see Figure 3.2 for facility locations). (See FH 2004 for additional details on specific facilities.) Text describing new facilities or those that would be substantially modified under the alternative groups described in Section 3 is presented in text boxes to distinguish those facilities from existing facilities. This section also briefly discusses the transportation of waste and the Hanford pollution prevention/waste minimization program.

### **2.2.1 Storage Facilities**

The primary storage facility for solid radioactive and mixed waste at Hanford is the CWC. Storage also exists at WRAP, the T Plant Complex, and the LLBGs. The T Plant Complex, described in Section 2.2.2.4 as a treatment facility, would be used to store sludge from the K Basins, and potentially other RH waste, as space is available. Trenches in the LLBGs have been used for retrievable storage of TRU wastes and other materials. Additional details on the CWC, trenches and caissons in the LLBGs, and grout vaults are described in the following sections.

#### **2.1.4.1 Immobilized Low-Activity Waste Packages**

During processing in the WTP, the molten ILAW can be directly poured into stainless steel canisters to produce a monolithic glass waste form, or it can be poured into water to produce waste in the form of granular glass particles similar to coarse sand, called cullet. The canisters for the monolithic glass waste form would be approximately 2.3 m (7.5 ft) in height and 1.22 m (4.0 ft) in diameter and would weigh up to 10,000 kg (22,000 lb) each when filled. An estimated 81,000 canisters would be filled using the monolithic pour compared to 140,000 canisters being filled with cullet. Dose rates from the cylinders are high enough (~500 mR/hr on contact) that remote handling would be required. The principal components in ILAW glass are silica, calcium oxide, and sodium oxide, making it a soda-lime silicate glass. Other waste forms are being considered for ILAW and are being analyzed in the Tank Closure EIS (68 FR 1052).

#### **2.1.4.2 WTP Melters**

The vitrification of Hanford tank wastes would use large melters comprised of metal structural components and ceramic refractories to contain the molten glass. With use, the refractories are slowly consumed and some metal components can become corroded. For this EIS, it was assumed the WTP melters would periodically be replaced with new units, and only the melters that meet HSSWAC would be managed and disposed of onsite in accordance with applicable requirements for RH MLLW. Packages containing the melters can have dimensions of 4.6 to 7.6 m (15 to 25 ft) in length, height, and width; can weigh 545,000 kg (600 tons); and would require special handling.

## **2.2 Hanford Waste Storage, Treatment, and Disposal Facilities, and Transportation Capabilities Related to the Proposed Action**

This section briefly describes existing and proposed facilities for the management of Hanford solid waste. The facilities provide storage, treatment, or disposal functions and are grouped by their primary function in the following discussion (see Figure 3.2 for facility locations). (See FH 2004 for additional details on specific facilities.) Text describing new facilities or those that would be substantially modified under the alternative groups described in Section 3 is presented in text boxes to distinguish those facilities from existing facilities. This section also briefly discusses the transportation of waste and the Hanford pollution prevention/waste minimization program.

### **2.2.1 Storage Facilities**

The primary storage facility for solid radioactive and mixed waste at Hanford is the CWC. Storage also exists at WRAP, the T Plant Complex, and the LLBGs. The T Plant Complex, described in Section 2.2.2.4 as a treatment facility, would be used to store sludge from the K Basins, and potentially other RH waste, as space is available. Trenches in the LLBGs have been used for retrievable storage of TRU wastes and other materials. Additional details on the CWC, trenches and caissons in the LLBGs, and grout vaults are described in the following sections.

### 2.2.1.1 Central Waste Complex

The CWC is a series of handling areas, storage buildings, and storage modules that have been built in several phases for the receipt, inspection, storage, and limited treatment (that is, absorption and solidification of free liquids, neutralization of corrosive materials, and stabilization and encapsulation in solid waste matrixes) of wastes and materials awaiting verification, treatment, or disposal. The primary waste types of interest to the HSW EIS, with respect to storage, are MLLW and TRU waste, because most LLW is sent directly to burial. An aerial view of the CWC is shown in Figure 2.3. The Solid Waste Inventory Tracking System lists CWC inventory at the end of 2001 as a total of about 9200 m<sup>3</sup> (325,000 ft<sup>3</sup>), composed mainly of MLLW [7350 m<sup>3</sup> (260,000 ft<sup>3</sup>)] and TRU waste [1560 m<sup>3</sup> (55,000 ft<sup>3</sup>)] (FH 2004). Its capacity is estimated to be 16,700 m<sup>3</sup> (589,000 ft<sup>3</sup>). Most MLLW and TRU waste received since 1987 is now stored in the CWC, including TRU waste relocated from other facilities at Hanford. The CWC could be expanded as needed for future receipts of waste that require storage, including any retrievably stored waste removed from the LLBGs.

The CWC waste is segregated by content to assure compatibility of the contents of the various storage containers (for example, acidic and basic materials are stored separately). In addition to MLLW and TRU waste, some non-conforming LLW and GTC3 LLW may also be stored in CWC. All waste containers must be CH or shielded to CH levels to be accepted at CWC. Some RH waste is stored at CWC by shielding it to CH levels. Most of the waste is packaged in 208-L (55-gal) drums; however, other package sizes can also be stored.

Typically, four drums are banded onto a pallet to allow easy handling by forklifts and stacked up to three layers high. Aisles are provided to gain access to the drums for required routine visual inspections (see Figure 2.4). The packages have identifying numbers (bar codes) for tracking their location and contents. Waste remains within the CWC until it is shipped to other facilities for processing or disposal.



M0212-0286.9A  
HSW EIS 12-10-02

**Figure 2.3.** Aerial View of the Central Waste Complex





M0212-0286.9B  
HSW EIS 12-10-02

**Figure 2.4.** Storage of Waste Drums in Central Waste Complex

#### **2.2.1.2 Retrievable Storage of Suspect TRU Waste in LLBG Trenches**

Beginning in 1970, suspect TRU waste, primarily CH but also some RH waste, was placed in a retrievable configuration at the Hanford Site in specific trenches in Burial Grounds 218-W-3A, 218-W-4B, 218-W-4C, and 218-E-12B. From 1972 to 1973, drums of TRU waste were placed in a concrete V-trench (218-W-4B) with a metal cover. Beginning in 1974, drums and boxes were stored in trenches on either asphalt pads or plywood and covered with wood sheathing, tarps, and plastic. A layer of at least 1.2 m (4 ft) of earth was placed over the tarp cover. After 1985, most TRU waste was sent to an above ground storage facility. However, small amounts of TRU waste have occasionally been added to the trench inventory. A small volume of this waste was never covered with dirt and has recently been removed from the trenches and placed in the CWC. About 14,600 m<sup>3</sup> (516,000 ft<sup>3</sup>) of suspect TRU waste remain in the trenches (FH 2004). DOE began retrieving TRU waste from the LLBGs in FY 2004 for certification and shipment to WIPP (DOE 2002a).

#### ***Proposed New/Modified Storage Facility: Additional CWC Buildings***

Additional storage buildings would be constructed at CWC as part of the No Action Alternative. The new buildings would be similar to the larger existing buildings. Each new building would be about 37 m (120 ft) wide by 55 m (180 ft) long by 6.1 m (20 ft) high to the eaves, and would hold about 4,600 208-L (55-gal) drums. The interior floors would be sloped with raised perimeter curbing to contain and direct spilled liquids to collection sumps. The floors would be sealed with impervious epoxy resins to reduce the impacts of any liquid spills.



### 2.2.1.3 Retrievable Storage of TRU Waste in LLBG Caissons

The waste caissons, designed to store RH waste, are reinforced cylindrical steel and concrete vaults 2.4 m (8 ft) in diameter and 3 m (10 ft) high. Four caissons have received TRU waste. These four caissons were buried in Trench 14 of Burial Ground 218-W-4B. The caissons have an offset connecting chute between the caisson and the soil surface to reduce radiation dose to workers as the waste was deposited. Gases from the caissons are passively filtered through high-efficiency particulate air (HEPA) filters. Caisson configuration is illustrated in Figure 2.5. Waste containers similar to 3.8-L and 18.9-L (1- and 5-gal) paint cans were dropped into the loading chute from a shielded shipment cask. Each caisson has been limited to a total plutonium-239 inventory equivalent of 5 kg (11 lb). Radiation levels in the caissons have been measured at 1500 to 10,000 R/hr (FH 2004).

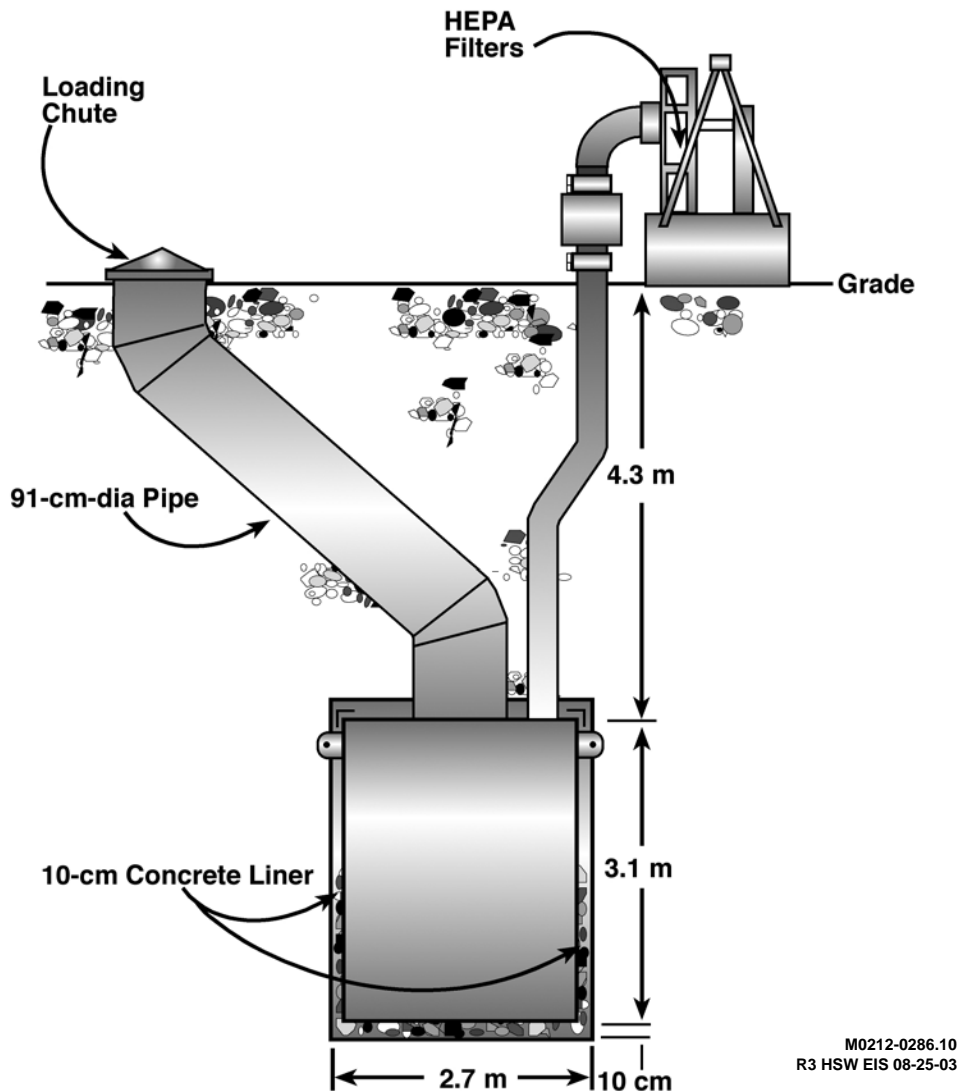


Figure 2.5. Schematic Drawing of RH TRU Caisson in the LLBGs

#### 2.2.1.4 Interim Storage of ILAW in Grout Vaults

Grout vaults constructed in the 1980s would be used for interim storage of ILAW in the cullet form in the No Action Alternative. The existing vaults were designed to store low-activity tank waste in a grout-like form. Modifications to the vaults would be required before ILAW storage could take place. The modifications include excavation of surface materials, disassembly of vault covers, minor repairs to concrete surfaces and testing of leachate collection system, construction of superstructure over each vault to provide protection against wind and rain, and installation of additional leak detection monitoring. Once modifications are completed, ILAW canisters containing glass cullet would be transported from the WTP to the vaults via a tractor-trailer. A crane would emplace the canisters. This process would continue until such time that new vaults could be constructed for disposal of the canisters. Then the canisters would be removed from the grout vaults and placed into the disposal vaults along with newly generated canisters.

#### 2.2.2 Treatment and Processing Facilities

Treatment and processing facilities include those used to treat MLLW to applicable regulatory standards, as well as those where TRU waste is processed and certified for shipment to WIPP. DOE is currently using a combination of Hanford and offsite facilities to treat some CH MLLW and CH TRU waste. Commercial facilities have provided treatment capabilities for limited quantities of CH MLLW under two existing contracts. DOE does not currently have facilities for treatment of most CH MLLW, treatment of RH MLLW or TRU waste, or for non-standard containers of MLLW and TRU waste. The ETF provides treatment for leachate from the MLLW trenches. Cat 3 wastes are treated either by in-trench grouting or placement in HICs as discussed in Section 2.2.3.

<b><i>Treatment and Processing Facilities</i></b>
<u>Existing Facilities</u>
<ul style="list-style-type: none"><li>• WRAP</li><li>• Mobile TRU Waste Processing Facilities (APLs)</li><li>• T Plant Complex</li><li>• ETF</li><li>• Commercial Treatment Facilities</li><li>• In-Trench Grouting</li><li>• Other DOE sites</li></ul>
<u>Proposed New/Modified Facilities</u>
<ul style="list-style-type: none"><li>• Modified T Plant Complex</li><li>• New Waste Processing Facility</li><li>• Pulse Driers</li><li>• Commercial Treatment Facilities</li></ul>

##### 2.2.2.1 Waste Receiving and Processing Facility

The Waste Receiving and Processing Facility (WRAP) began operation in 1998 on the Hanford Site for management of TRU waste, MLLW, and LLW. The major function of WRAP is the inspection, repackaging, and certification of CH TRU waste to prepare it for transport and disposal at WIPP. The facility is also used to verify that incoming LLW meets HSSWAC, and to characterize MLLW for quality assurance purposes. A picture of WRAP is shown in Figure 2.6.

WRAP can accept CH drums and standard waste boxes. Handling of drums and boxes can be performed manually or by use of automated guided vehicles. WRAP provides the capability for non-destructive examination (NDE) and non-destructive assay (NDA) of incoming waste. The NDE is an X-ray process used to identify the physical contents of the waste containers in supporting waste characterization (see Figure 2.7). The NDA is a neutron or gamma energy assay system used to determine radionuclide content and distribution in waste packages.

#### 2.2.1.4 Interim Storage of ILAW in Grout Vaults

Grout vaults constructed in the 1980s would be used for interim storage of ILAW in the cullet form in the No Action Alternative. The existing vaults were designed to store low-activity tank waste in a grout-like form. Modifications to the vaults would be required before ILAW storage could take place. The modifications include excavation of surface materials, disassembly of vault covers, minor repairs to concrete surfaces and testing of leachate collection system, construction of superstructure over each vault to provide protection against wind and rain, and installation of additional leak detection monitoring. Once modifications are completed, ILAW canisters containing glass cullet would be transported from the WTP to the vaults via a tractor-trailer. A crane would emplace the canisters. This process would continue until such time that new vaults could be constructed for disposal of the canisters. Then the canisters would be removed from the grout vaults and placed into the disposal vaults along with newly generated canisters.

#### 2.2.2 Treatment and Processing Facilities

Treatment and processing facilities include those used to treat MLLW to applicable regulatory standards, as well as those where TRU waste is processed and certified for shipment to WIPP. DOE is currently using a combination of Hanford and offsite facilities to treat some CH MLLW and CH TRU waste. Commercial facilities have provided treatment capabilities for limited quantities of CH MLLW under two existing contracts. DOE does not currently have facilities for treatment of most CH MLLW, treatment of RH MLLW or TRU waste, or for non-standard containers of MLLW and TRU waste. The ETF provides treatment for leachate from the MLLW trenches. Cat 3 wastes are treated either by in-trench grouting or placement in HICs as discussed in Section 2.2.3.

<b><i>Treatment and Processing Facilities</i></b>
<u>Existing Facilities</u>
<ul style="list-style-type: none"><li>• WRAP</li><li>• Mobile TRU Waste Processing Facilities (APLs)</li><li>• T Plant Complex</li><li>• ETF</li><li>• Commercial Treatment Facilities</li><li>• In-Trench Grouting</li><li>• Other DOE sites</li></ul>
<u>Proposed New/Modified Facilities</u>
<ul style="list-style-type: none"><li>• Modified T Plant Complex</li><li>• New Waste Processing Facility</li><li>• Pulse Driers</li><li>• Commercial Treatment Facilities</li></ul>

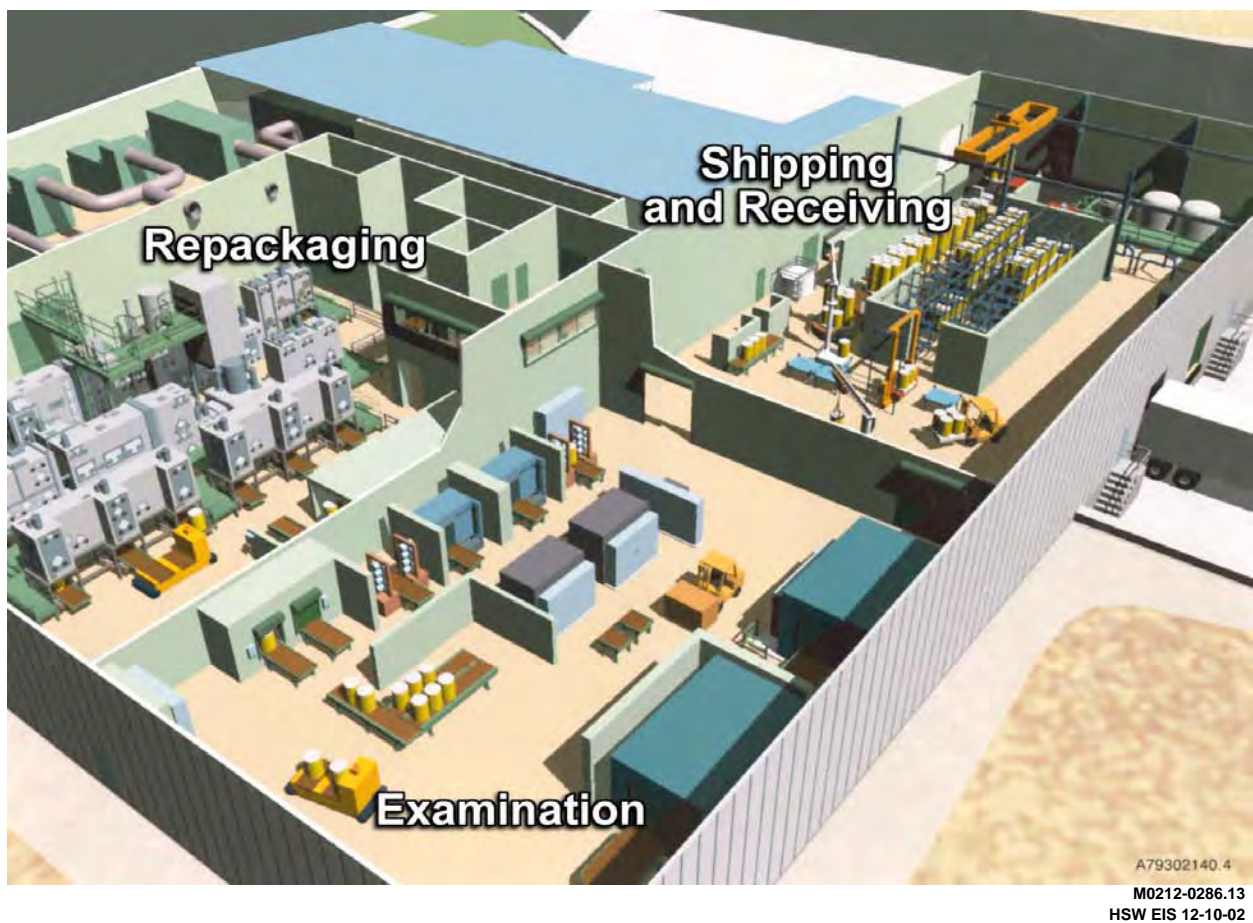
##### 2.2.2.1 Waste Receiving and Processing Facility

The Waste Receiving and Processing Facility (WRAP) began operation in 1998 on the Hanford Site for management of TRU waste, MLLW, and LLW. The major function of WRAP is the inspection, repackaging, and certification of CH TRU waste to prepare it for transport and disposal at WIPP. The facility is also used to verify that incoming LLW meets HSSWAC, and to characterize MLLW for quality assurance purposes. A picture of WRAP is shown in Figure 2.6.

WRAP can accept CH drums and standard waste boxes. Handling of drums and boxes can be performed manually or by use of automated guided vehicles. WRAP provides the capability for non-destructive examination (NDE) and non-destructive assay (NDA) of incoming waste. The NDE is an X-ray process used to identify the physical contents of the waste containers in supporting waste characterization (see Figure 2.7). The NDA is a neutron or gamma energy assay system used to determine radionuclide content and distribution in waste packages.

A layout for the 4806 m<sup>2</sup> (51,700 ft<sup>2</sup>) facility is shown in Figure 2.8. The layout illustrates the major functions of shipping and receiving, examination, and repackaging within WRAP. Many operations at the facility, such as handling, opening, and processing waste packages, are conducted in gloveboxes or using automated equipment to minimize worker exposure to radioactive and hazardous materials. Certified CH TRU waste drums and standard waste boxes are loaded into TRUPACT-II shipping containers for transport from the facility to WIPP. Figure 2.9 shows the loading of a TRUPACT-II container in the WRAP.

WRAP also has limited treatment capabilities for TRU waste and MLLW by deactivation, solidification or absorption of liquids, neutralization of corrosives, amalgamation of mercury, microencapsulation, macroencapsulation, volume reduction by super compaction, stabilization of reactive waste, and repackaging waste as needed.



**Figure 2.8.** Layout for the Waste Receiving and Processing Facility



M0212-0286.14  
HSW EIS 12-10-02

**Figure 2.9.** Transuranic Package Transporter-II Being Loaded in the Waste Receiving and Processing Facility

### **2.2.2.2 Mobile TRU Waste Processing Facilities**

Mobile TRU waste processing facilities, or Accelerated Process Lines (APLs), are being used at Hanford to accelerate the rate at which TRU waste can be certified and shipped to WIPP. The functions of the APLs are similar to functions in WRAP with capabilities to perform NDA, NDE, headspace gas sampling, repackaging, and visual examination of waste packages. The APLs also have a loadout facility for TRUPACT-IIs. The facilities are being developed in stages or modules so that the first module will process standard 55-gal drums and a second module will process larger boxes. Two stage-one APLs are anticipated, each with a capacity to process about 2000 CH drums per year. It is anticipated that the headspace gas-sampling units will be inside one of the CWC buildings. Other units will be located near the CWC buildings or in the LLBGs on ground that had previously been disturbed.

### **2.2.2.3 Commercial Treatment**

Commercial treatment services have been used to treat some Hanford MLLW streams. These treatment capabilities consist of both non-thermal and thermal processes. Two contracts were placed with



Allied Technology Group, Inc. (ATG) for thermal and non-thermal treatment of Hanford MLLW in a demonstration project beginning in 2000. Other commercial treatment contracts are being established by Hanford and through the broad spectrum contracts at Oak Ridge.

The non-thermal treatment contract provided for treatment of at least 1600 m<sup>3</sup> (56,500 ft<sup>3</sup>) of MLLW and has been successfully completed and a new commercial contract has now been established for continued treatment of MLLW. The MLLW will largely consist of debris waste and will be treated principally by stabilization and macroencapsulation. Waste being macroencapsulated is shown in Figure 2.10. The local commercial treatment facility has some capability for physical extraction neutralization, chemical oxidation, chemical reduction, microencapsulation, and deactivation. The local facility also has pretreatment capability for size reduction, drying, and sorting. The stabilization processes can be either cement or polymer based. Additional details on local commercial processes can be found in the related DOE environmental assessment (DOE 1998).

The thermal treatment contract was to begin in 2001 and provide processing of a minimum of 600 m<sup>3</sup> (21,200 ft<sup>3</sup>) and a maximum of 3585 m<sup>3</sup> (126,600 ft<sup>3</sup>) MLLW over a 5-year period. ATG planned to use a high-temperature plasma arc process to convert most organic contaminants to carbon dioxide and water (DOE 1999). However, the unit has not been able to process the contracted volumes of waste and is no longer operating. At this point, the future of the ATG thermal treatment unit remains uncertain.



M0212-0286.15  
HSW EIS 12-10-02

**Figure 2.10.** Macroencapsulation of Mixed Low-Level Waste Debris at a Commercial Treatment Facility

***Proposed New/Modified Treatment Facility: Commercial Treatment Facilities***

Additional contracts with commercial treatment facilities would provide treatment for CH MLLW and non-conforming LLW. Thermal treatment capabilities are still needed and may be available in the future either locally or at other commercial facilities.

**2.2.2.4 Leachate Treatment**

Lined disposal facilities are required to incorporate a leachate collection system (WAC 173-303). The collection system retains rain and snowmelt that may contact waste and leach hazardous constituents from the waste. The leachate from onsite mixed waste trenches and future lined disposal facilities would be collected and either sent to the 200 East Area Liquid Effluent Retention Facility (LERF) prior to treatment in the ETF or sent directly to ETF. Leachate is currently transported from lined disposal trenches by tanker truck. The ETF treats liquid waste using pH adjustment, filtration, ultraviolet light and peroxide destruction of organic materials, reverse osmosis, and ion exchange. The leachate to be treated at ETF is required to meet ETF waste acceptance criteria. The volume of leachate is expected to depend on the exposed surface area of the trenches.

***Proposed New/Modified Treatment Facility: ETF Replacement Capability***

The ETF is scheduled to shut down at the end of 2025. After 2025 pulse driers would be used for leachate treatment. The pulse driers treat leachate by evaporation, leaving behind solids as secondary waste. These secondary wastes would be treated, as necessary, and disposed of in MLLW trenches as part of MLLW action alternatives. Depending on the amount of trench space available, these secondary wastes may be stored in CWC as part of the No Action Alternative.

**2.2.2.5 T Plant Complex**

The T Plant Complex consists of a number of buildings, as shown in Figure 2.11. The T Plant canyon and tunnel (221-T Building) are used for handling and processing of materials that require remote handling. Spent commercial reactor fuel and other RH wastes have been stored in the T Plant canyon. Dry decontamination, inspection, segregation, verification, and repacking of RH and large items are performed in the canyon. Current plans are to use the water-filled basin and refurbished process cells at T Plant to provide storage for the K Basin sludge (DOE 2001a). The sludge is expected to remain in the T Plant canyon until a treatment facility is available.

The T Plant canyon was built of reinforced concrete during 1943 and 1944 as a chemical reprocessing plant for defense program materials and was subsequently converted to decontamination and support functions in 1957. The building is 21 m (68 ft) wide, 259 m (850 ft) long, and 23 m (74 ft) high. The 37 cells within the building are designed to accommodate very high levels of radioactivity, and most cells have concrete shielding that is 2.1 m (7 ft) thick.



M0212-0286.16  
 HSW EIS 12-10-02

**Figure 2.11.** View of the T Plant Complex with 2706-T Facility and the T Plant Canyon Noted

Inspection, verification, opening, sampling, sorting, and limited treatment and repackaging of LLW, MLLW, and TRU waste are performed in the 2706-T Facility and other areas in the T Plant Complex. The 2706-T Facility, initially constructed during 1959 and 1960, was remodeled in 1998 to expand decontamination and treatment capabilities.

***Proposed New/Modified Treatment Facility: Modified T Plant***

In some alternatives, the T Plant Complex would be modified to establish the capabilities to treat/process MLLW and TRU waste for which no treatment capability currently exists. These waste streams include RH MLLW, MLLW in non-standard packages, RH TRU waste, CH TRU waste in non-standard containers, and PCB-commingled TRU waste. Specific capabilities provided by this modified T Plant would include stabilization, macroencapsulation, deactivation, sorting, sampling, repackaging NDE, and NDA.

MLLW would be treated to meet applicable regulatory requirements so that it can be disposed of in the MLLW trenches. TRU waste would be processed and shipped to WIPP.



### ***Proposed New/Modified Treatment Facility: New Waste Processing Facility***

As an alternative to modifying T Plant and using commercial contracts for MLLW and TRU waste treatment, a new facility would be constructed to process/treat the same waste streams and have all of the capabilities identified above for the modified T Plant Complex and for commercial treatment.

CH MLLW in standard containers, non-conforming LLW, elemental lead, and elemental mercury would also be treated in this new facility. Specific capabilities provided by the new facility to treat these waste streams could include stabilization, macroencapsulation, thermal desorption, mercury amalgamation, deactivation, sorting, sampling, repackaging, NDE, and NDA.

The new facility location is assumed to be in the 200 West Area near WRAP, consistent with previous DOE proposals for a modular complex to process MLLW and TRU waste. The new facility would be expected to be larger than WRAP (FH 2004).

MLLW would be treated to meet applicable regulatory requirements so that it can be disposed of in the MLLW trenches. TRU waste would be processed and shipped to WIPP.

### **2.2.2.6 Treatment at Other Facilities**

The facilities described as treatment facilities in the preceding sections are not meant to restrict options for treating waste at other onsite facilities where operational considerations make treatment at alternate locations advisable or practical. Other options could include treatment at generator facilities, or treatment of some wastes at existing or planned storage and disposal facilities. For example, macroencapsulation or stabilization of large items, such as WTP melter and oversized equipment, might be performed more efficiently at the disposal site to avoid transporting them after the packages have been filled with grout or other stabilizing agent. As noted previously, processing and certification of TRU waste using APLs might involve carrying out some sampling procedures in the CWC. In such cases, the activities would be similar to those previously described for treatment of the waste streams, and the impacts would be substantially the same wherever treatment occurred.

#### ***Disposal Facilities***

##### Existing Facilities

- LLBGs
  - LLW Trenches
  - MLLW Trenches
- ERDF

##### Proposed New/Modified Facilities

- Existing Design Unlined LLW Trenches
- Deeper, Wider Unlined LLW Trenches
- Single Expandable Unlined LLW Trench
- Existing Design MLLW Trenches
- Deeper, Wider Lined MLLW Trenches
- Single Expandable Lined MLLW Trench
- Melter Trench
- ILAW Multiple Trenches
- ILAW Disposal Vaults
- Single Expandable ILAW Trench
- Modular Lined Combined-Use Disposal Facilities
- Closure Caps

### 2.2.3 Disposal Facilities

Facilities used for LLW and MLLW disposal at Hanford consist of the LLBGs and the Environmental Restoration Disposal Facility (ERDF). New or modified facilities would be developed for LLW, MLLW, ILAW, and WTP melters. Each of the existing and proposed new facilities considered in the alternative groups is described in this section.

TRU wastes are disposed of in New Mexico at WIPP, which is the DOE repository for TRU wastes. Hanford began shipping TRU waste to WIPP in the summer of 2000 and would continue shipping TRU waste to WIPP for disposal.

LLW has been buried on the Hanford Site since the start of the defense materials production mission. Six LLBGs are located in the 200 West Area (218-W-3A, 218-W-3AE, 218-W-4B, 218-W-4C, 218-W-5, and 218-W-6) and two LLBGs are in the 200 East Area (218-E-10 and 218-E-12B). These eight disposal facilities are collectively referred to as the LLBGs. See Appendix D for additional information about each LLBG. The LLBGs have historically been used for temporary storage of some waste (these functions were previously described). Figure 2.12 shows a picture of a burial ground with both open and covered trenches.



M0212-0286.17  
HSW EIS 12-10-02

**Figure 2.12.** Aerial View of a Low Level Burial Ground

The total volume of LLW placed in the LLBGs between 1962 and 1999 was about 283,000 m<sup>3</sup> (10,000,000 ft<sup>3</sup>). The waste occupies an area of 141 ha (348 ac). The LLBGs occupy a total area of 425 ha (1050 ac); thus, approximately two-thirds of the LLBGs would be available for future waste disposal.

Within the LLBGs, several techniques can be used to provide extra confinement for Cat 3 and approved GTC3 LLW or MLLW. These techniques include placement of higher-activity LLW or MLLW deep within the trench, burial in HICs, and in-trench grouting. The higher activity wastes are usually placed in the bottom of the trenches with Cat 1 wastes placed on top of the Cat 3 and GTC3 wastes. This is intended to reduce the risk of intrusion into the higher-hazard wastes.

HICs are large concrete boxes or cylinders into which the Cat 3 and approved GTC3 LLW or MLLW are placed for burial. The HIC is first placed within the burial trench and the waste is loaded into the HIC. Figure 2.13 shows four HICs in the bottom of a burial trench. The HIC is then sealed with a lid and buried with other waste placed around it. The HIC provides additional containment for higher activity waste while the radioactivity decays. The concrete used to construct the HICs also changes the chemistry of the soil in the immediate vicinity of the waste, which reduces the mobility of certain radionuclides and hazardous components.



**Figure 2.13.** High-Integrity Containers in a Low-Level Waste Disposal Trench

In-trench grouting normally involves placing the CH Cat 3 and approved CH GTC3 LLW or MLLW on a concrete pad or on spacers, installing reinforcement steel and forms around the waste, and covering the waste with fresh concrete to encapsulate the waste within a concrete barrier. The process is limited to CH wastes because of the need for workers to be in close contact with the waste to place concrete forms around it. Steel fibers are incorporated into the concrete to increase its strength. The resulting monoliths, such as the one shown in Figure 2.14, have a maximum size of 6.4 m (21 ft) long, 4 m (13 ft) high, and 2.7 m (9 ft) wide with a minimum wall thickness of 0.15 m (0.5 ft). After curing, the encased waste is covered with at least 2.4 m (8 ft) of soil. As with the HICs, in-trench grouting provides additional containment for the waste and retards migration of some radionuclides from the LLBGs. In-trench grouting is a more economical method for encapsulation of Cat 3 and GTC3 LLW or MLLW than using the HIC. Large containers of waste may also be placed into the burial grounds and then filled with grout.

The use of HICs versus in-trench grouting for CH waste is determined on a case-by-case basis. Generally, HICs are used for RH wastes while CH wastes are in-trench grouted. However, HICs can be used for either RH or CH waste.

Stabilization or treatment by macroencapsulation at the disposal facility has been proposed for some oversized Hanford MLLW, such as long-length equipment from the tank farms. For purposes of analysis in this EIS, these waste streams were assumed to be treated at the generator site, in T Plant, or at a new onsite facility. However, transporting the treated waste could be difficult because of its weight, and as a result, about 1100-1700 m<sup>3</sup> of containerized MLLW is being considered for treatment at the disposal facility. The process would be similar to that currently employed for disposal of Cat 3 MLLW, as illustrated in Figure 2.15, and the consequences of treating the waste are expected to be similar wherever



M0212-0286.19  
HSW EIS 12-10-02

**Figure 2.14.** Trench Grouted Wastes





M0212-0286.900  
HSW EIS 06-01-03

**Figure 2.15.** Treatment by Macroencapsulation at the LLBGs

the treatment occurs. Therefore, the EIS evaluation of treating this waste at a dedicated facility is expected to bound the consequences of treating waste at the disposal site, and a separate analysis has not been performed for that activity (see Section 5).

The amount of waste that can be disposed of in a trench varies depending on the specific characteristics of the waste (e.g., CH vs. RH, Cat 1 vs. Cat 3) and how much cover soil is placed on the waste. Typically, about 30 percent to 50 percent of the total trench volume is filled with waste.

### **2.2.3.1 LLW Disposal Trenches**

The existing LLW trenches currently comprise a series of relatively long, unlined, narrow trenches for disposal of LLW. The dimensions of existing trenches in the LLBGs vary with location. Typically, trenches are about 12 m (40 ft) wide at the base; however, some are “V” shaped and some are wider with flat bottoms. The trenches are excavated to a depth of approximately 6 m (20 ft). The waste is placed within the trenches and the location of each waste package is recorded in waste management records. Periodically the waste may be covered with dirt for interim periods before adding additional wastes. After the trenches are filled with waste to the desired level, a 2.6-m (8-ft) layer of soil is placed over the waste so the surface is near the original grade. The trenches are inspected weekly to note any areas of

subsidence, and when necessary corrective actions are taken in a timely manner. Layouts of the trenches within each LLBG are shown in Appendix D.

***Proposed New/Modified Disposal Facility: Existing Design Unlined LLW Trenches***

Trenches of the current design would be used to expand LLBG disposal capacity. Dimensions are nominally 12 m (39 ft) wide at the base, 6.1 m (20 ft) deep, 20 m (66 ft) wide on top, and 350 m (1150 ft) long. However, the dimensions of each trench are modified to fit within the available space of each specific burial ground. The number of new trenches would depend on the amount and category of LLW received.

***Proposed New/Modified Disposal Facility: Deeper, Wider Unlined LLW Trenches***

Deeper, wider LLW trenches would be used to expand LLBG disposal capacity. The reference design for deeper, wider LLW trenches was assumed to be 67 m (220 ft) wide at the top, 7 m (23 ft) wide at the bottom, about 18 m (60 ft) deep, and 350 m (1150 ft) long. However, the dimensions of each trench are modified to fit within the available space of each specific burial ground. The number of new trenches would depend on the amount and category of LLW received.

***Proposed New/Modified Disposal Facility: Single Expandable Unlined LLW Trench***

A single expandable unlined LLW trench would be used to expand disposal capacity for LLW. The trench would be similar to those for ERDF (see Section 2.2.3.3), except they would not contain any liners for leachate collection. It would also be constructed in the 200 W Area so that they could be expanded as needed for future wastes. The design of such a facility is in the earliest stage of conceptual design. The potential benefit of such a facility is economy of scale for construction and land use. The size of the trench would depend on the amount and category of LLW received. The trench would be about 18 to 21 m (60 to 70 ft) deep and would require 3.8 to 8.9 ha (1.5 to 3.6 ac).

### **2.2.3.2 MLLW Trenches**

The two existing MLLW trenches (218-W-5, trenches 31 and 34) are located within a LLBG but, for the HSW EIS, they are considered separately from the other LLW disposal trenches. The trenches are permitted for MLLW disposal (DOE-RL 1997). One trench (see Figure 2.16) is currently being used as a MLLW disposal unit. The floor dimensions of the trenches are about 30.5 m (100 ft) wide by 76.2 m (250 ft) long and 9.1-10.7 m (30-35 ft) deep. The floor slopes to allow collection of leachate (rain or snow melt that has permeated through the waste). The surface dimensions are approximately 91 m (300 ft) wide by 137 m (450 ft) long and encompass approximately 1.3 ha (3.2 ac) of land.

Applicable regulations (WAC 173-303) require that waste trenches contain liners to collect any leachate that contacts the waste during the operating period. All liquids collected in the leachate collection system would be treated before disposal as discussed in Section 2.2.2.3. The existing MLLW trenches would be capped in accordance with applicable regulations.



M0212-0286.20  
HSW EIS 12-10-02

**Figure 2.16.** Mixed Low-Level Waste Disposal Trench

***Proposed New/Modified Disposal Facility: Existing Design MLLW Trenches***

Additional trenches of the existing design would be needed. New MLLW trenches would be the same as those described above for the existing MLLW trenches. They would also be constructed in the 200 East Area to provide better access to ETF for leachate treatment. Regulations require that waste trenches contain liners to collect any leachate that contacts the waste during the operating period. All liquids collected in the leachate collection system would be treated before disposal. The trenches would be capped in accordance with applicable regulations.

***Proposed New/Modified Disposal Facility: Deeper, Wider Lined MLLW Trenches***

Deeper, wider trenches would be constructed to increase the efficiency and reduce the cost of future MLLW disposal at Hanford. They would also be constructed in the 200 East Area to provide better access to ETF for leachate treatment. The deeper, wider MLLW trenches would be about 80 m (262 ft) wide as the base and 188 m (617 ft) wide at the top, with a depth of 18 m (60 ft). The length of the trenches would be 170 m (558 ft) long for the Lower Bound volume and 340 m (1115 ft) long for the Upper Bound volume. Regulations require that waste trenches contain liners to collect any leachate that contacts the waste during the operating period. All liquids collected in the leachate collection system would be treated before disposal. The trenches would be capped in accordance with applicable regulations.

***Proposed New/Modified Disposal Facility: Single Expandable Lined MLLW Trench***

A single expandable lined trench would be used to expand disposal capacity for MLLW. It would also be constructed in the 200 East Area so that it could be expanded as needed for future wastes and have better access to ETF for leachate treatment. The design of such a trench is in the earliest stage of conceptualization. The potential benefit of such a trench is economy of scale for construction and land use. The size of the trench would depend on the future volume of MLLW to be disposed of. The trench would be about 18 to 21 m (60 to 70 ft) deep and would require 3.8 to 8.9 ha (1.5 to 3.6 ac).

***Proposed New/Modified Disposal Facility: Lined Melter Trench***

The vitrification of tank waste on the Hanford Site would result in the need to dispose of WTP melters. These items would be treated at the vitrification facility to ready them for disposal. The large melters would be taken to a lined trench designed for them. The dimensions for the melter trench would be about: 270 m (886 ft) long, 120 m (165 ft) wide, and 21 m (70 ft) deep. To place the melters into the trench a ramp with a 6 percent grade into the trench is planned. Leachate from the melter trench would be treated along with other MLLW trench leachate. The trench would be capped in accordance with applicable regulations.

**2.2.3.3 ILAW Disposal Facilities**

See the following text boxes for a description of the proposed ILAW disposal facilities.

***Proposed New/Modified Disposal Facility: ILAW Disposal in an Expandable Trench***

ILAW would be disposed of in a single expandable trench located in the 200 East Area just southwest of the PUREX facility. A single trench 183 m wide by 365 m long by 10 m deep could accommodate the total mission quantity of ILAW (Aromi and Freeberg 2002). The bottom of the trench would contain a double leachate collection system similar to a RCRA Subtitle C landfill.

Initially two cells, each 62 m wide by 76 m long, would be installed. These cells could accommodate about 22,000 ILAW packages (Aromi and Freeberg 2002). Additional cells would be installed as necessary to accommodate the ILAW.

The canisters would be emplaced by a crane. The crane would be equipped with instrumentation and controls to allow the logging of each canister's position, serial number, and date using a global positioning system (GPS).

After several canisters are emplaced, the crane operator, using a material-handling bucket, would place fill between and over the canisters, thereby minimizing the overall radiation exposure to the crane operator.



***Proposed New/Modified Disposal Facility: ILAW Disposal in Multiple Trenches***

The current design for each monolithic ILAW canister disposal trench is for a bottom dimension of 20 m (66 ft) by 210 m (690 ft). The trenches would be 10 m (33 ft) in depth with a top dimension of 80 (300 ft) by 280 m (920 ft) with 3:1 side slopes. The bottom of the trench would contain a double leachate collection system similar to a RCRA Subtitle C landfill (Burbank 2002).

The monolithic ILAW canisters would be removed from the transport vehicles using a large crane with a 90-m (300-ft) boom and a 22-metric ton (25-ton) capacity at 85 m (280 ft). The crane would be equipped with instrumentation and controls to allow the logging of each canister's position, serial number, and date using a GPS. This information would be relayed to the support facility for real-time readout and tracking of all canisters placed.

After several canisters are emplaced, the crane operator, using a material handling bucket, would place fill between and over the canisters, thereby minimizing the overall radiation exposure to the crane operator. Final cover of each layer to provide 1 m (3 ft) compacted cover would be completed by standard heavy earthmoving equipment.

Three layers of canisters would be placed into each trench with the first layer containing approximately 1,900 canisters; the second layer containing approximately 4,500 canisters; and the third layer containing approximately 7,300 canisters. The total capacity of each trench would be approximately 13,700 canisters (Burbank 2002).

An interim barrier would be placed atop each trench as it is filled. The first layer is backfill, which would vary in thickness with a minimum depth of 1.3 m (4.3 ft) and would provide a slope of not greater than 2 percent from the center of the trench to the outer edges. To minimize leachate collection, a temporary weather barrier, 'rain cover' or surface liner would be placed on top of this slope as part of operations activities. As the final closure activities would not occur for several years following filling of a trench, an interim cover consisting of two layers of sand and gravel would be placed as part of the operations activities. This interim cover would be a minimum of 2 m (7 ft) thick to provide additional protection from water intrusion. The trenches would be capped in accordance with applicable regulations.

***Proposed New/Modified Disposal Facility: ILAW Disposal Vaults***

Under the No Action Alternative 66 new vaults would be constructed onsite for the disposal of the ILAW cullet. Each vault would be an estimated 37 m (120 ft) long by 10 m (33 ft) wide by 15 m (50 ft) deep with a capacity to hold 5,300 m<sup>3</sup> (7,000 yd<sup>3</sup>) of ILAW (DOE 2001c). These vaults would contain a leachate collection system and an array of monitoring wells. The canisters would be emplaced by a gantry crane. The crane would be equipped with instrumentation and controls to allow the logging of each canisters position, serial number, and date using a GPS. An interim barrier would be placed atop each vault as it is filled. The interim barrier would consist of backfill of variable thickness but a minimum depth of 1.3 m (4.3 ft). The interim barrier would also contain a temporary surface liner and an interim cover of sand and gravel atop the backfill. The total thickness of the interim barrier would be at least 3.3 m (11 ft).

#### 2.2.3.4 Environmental Restoration Disposal Facility

ERDF, which began operation in 1996, is located in the center of the Hanford Site between the 200 East and 200 West Areas. ERDF is a large-scale, evolving landfill, complete with ancillary facilities as shown in Figure 2.17. It is designed to receive and isolate low-level radioactive, hazardous and mixed wastes. ERDF is a RCRA- and TSCA-compliant landfill authorized under CERCLA. The facility complies with all substantive elements of applicable or relevant and appropriate requirements identified through the CERCLA process, including EPA and Washington State codes, standards, and regulations, as well as with DOE orders. Administrative requirements such as RCRA permitting are not required for disposal of CERCLA waste from Hanford cleanup actions.



M0212-0286.686  
HSW EIS 02-20-03

**Figure 2.17.** Environmental Restoration Disposal Facility (ERDF)

Four disposal cells currently make up ERDF. The first two cells are each 21 m (70 ft) deep, 152 m (500 ft) long, and 152 m (500 ft) wide at the bottom and were completed in 1996. Construction of two additional cells of the same size was completed in 2000. Two additional cells are currently under construction. An interim cover was placed over the filled portions of the first two cells. Design and

construction of the final cover will not begin until cells #3 and #4 are filled. ERDF can be expanded further if necessary. It is currently authorized to be expanded up to eight cells. Capacity of the current four-cell configuration is 4.7 billion kg (5.2 million tons).

The cells are lined with a RCRA Subtitle C-type liner, and have a leachate collection system. The facility is monitored regularly and when closed will continue to be monitored to ensure that human health and the environment are protected.

ERDF is designed to provide disposal capacity, as needed, to accommodate projected Hanford cleanup waste volumes over the next 20 to 30 years. It is being included in this EIS as an alternative disposal site to the LLBGs.

***Proposed New/Modified Disposal Facility: Modular Lined Combined-Use Disposal Facility***

A Modular Lined Combined-Use Disposal Facility is similar in configuration and size to ERDF. The facility could involve three different configurations. The first and most comprehensive would include LLW, MLLW, melters, and ILAW (Aromi and Freeberg 2002). The second would include only LLW and MLLW, and the third would include only melters and ILAW. Several locations have been considered for the facility, including near PUREX, so as to be close to the WTP, near the existing LLBGs in 200 East, and at ERDF. As with other disposal facilities, it would be capped in accordance with applicable regulations.

### **2.2.3.5 Liners for Waste Disposal Facilities**

DOE currently has two double-lined solid waste disposal facilities on the Hanford Site: ERDF and two RCRA-permitted mixed waste trenches in the LLBGs. The RCRA-compliant waste disposal cells liner system consists of series of layers as shown in Figure 2.18. Additional liner technologies are discussed in Appendix D.

The geotextile layers provide a filtration/separation medium when placed adjacent to the sub-grade and between the geomembrane and the leachate collection system's layers. The geomembrane is to prevent the downward movement of contaminants. During liner installation, great care is taken to avoid mechanical tearing of the liner material and generally, a very comprehensive onsite liner system installation Quality Assurance Program is followed to ensure the integrity and longevity of the liner system.

Polyethylene geomembranes provide a highly impermeable barrier to gasses and liquids in order to mitigate or eliminate ground water contamination. The high-density polyethylene (HDPE) geomembranes are resistant to corrosion and most chemicals, resistant to biological degradation, and resistant to ultra-violet light degradation. They are also flexible, thereby permitting ground movement and contraction and swelling due to temperature fluctuations without cracking and unaffected by wet/dry cycle (unlike bentonite clays).

HDPE is chemically resistant because it is essentially inert, and because of its high density and resultant low permeability, it resists penetration by chemicals. Chemicals that do react with HDPE are primarily oxidizing agents like nitric acid and hydrogen peroxide. Oxidation will only occur under two conditions: 1) the oxidizer must be in high concentrations, and 2) the material must receive a sufficient supply of energy to activate the reaction (Tisinger and Giroud 1993). If oxidation does occur, the HDPE material becomes soft and brittle and therefore becomes subject to stress cracking. Under anaerobic conditions or conditions devoid of energy, oxidation cannot occur. Because most waste facilities are typically anaerobic and the liner is buried and therefore not directly exposed to the sunlight, the process of oxidative degradation of HDPE liners is highly unlikely. Furthermore, most HDPE liners contain antioxidants that further mitigate the impacts of oxidation on liner degradation.

### **2.2.3.6 Closure Barriers**

Closure barriers (also known as “caps”) are planned for the disposal trenches in accordance with applicable regulations. Because the design and timing of the barriers is still being decided, the various design options are still being considered. For the EIS analysis the Modified RCRA Subtitle C Barrier was selected. Other closure barrier designs are described in Appendix D.

The Modified RCRA Subtitle C Barrier is designed to provide long-term containment and hydrologic protection for a performance period of 500 years with no maintenance being conducted after an assumed 100-year institutional control period. The performance period is based on radionuclide concentration and activity limits for Cat 3 LLW. The Modified RCRA Subtitle C Barrier, shown in Figure 2.19, is composed of eight layers of durable material with a combined minimum thickness of 1.7 m (5.5 ft) excluding the grading fill layer. This design incorporates RCRA “minimum technology guidance” (MTG) (EPA 1989), with modifications for extended performance. One major change is the elimination of the clay layer, which may desiccate and crack over time in an arid environment. The geo-membrane component has also been eliminated because of its uncertain long-term durability. The design also incorporates provisions for bio-intrusion and human intrusion control.

A borrow pit to supply the local materials for the barriers would be developed at Areas B and C in accordance with the discussion in Appendix D.

#### ***Proposed New/Modified Disposal Facility: LLBG Closure Barrier or Cap***

MLLW trenches are capped in accordance with applicable regulations. The LLBGs would be closed and capped beginning in 2046. While the final design for the closure cap or barrier has not yet been decided, the RCRA Modified Subtitle C Barrier illustrated in Figure 2.19 has been used for the HSW EIS analysis. Alternative barrier designs are discussed in Appendix D. A discussion of the borrow pits in Areas B and C that are assumed to be used to derive some of the capping material is contained in Appendix D.

## 2.2.4 Transportation

Solid radioactive waste is currently transported on the Hanford Site by truck. The site has reactivated its rail system. Shipment of waste by rail may require constructing a spur or developing intermodal transfer capability from the existing rail lines, and if such construction and capability is proposed it would be evaluated under future NEPA reviews. Section 4.8.5 provides additional information on the Hanford transportation system features. Section 5.8 (Volume I) and Appendix H (Volume II) provide additional information on rail shipments.

### 2.2.4.1 Transportation Overview

About 300 million hazardous material<sup>(a)</sup> shipments (DOT 1998) occur in the United States every year. About 3 million (1 percent) of these involve shipments of radioactive material.<sup>(b)</sup> Currently, less than one percent of the 3 million radioactive material shipments are DOE shipments (NEI 2003). The number of LLW and MLLW shipments is expected to rise over the next five years. The number of shipments expected to be received at Hanford as part of the proposed action is addressed in the environmental impacts analysis (Section 5.8 and Appendix H). The annual peak number of DOE radioactive material shipments is expected to increase due to HLW, TRU waste, and spent nuclear fuel shipments and due to acceleration of cleanup activities. However, acceleration of cleanup activities would not change the total number of shipments. In addition, the annual number of DOE radioactive material shipments would continue to be small in comparison to the total number of hazardous material shipments nationwide.

Even though the number of DOE shipments will continue to be relatively small, DOE shipments would represent a large amount of the radioactivity being shipped. Of DOE's radioactive materials, LLW, MLLW, and TRU waste will account for about 90 percent by volume, but less than 6 percent by radioactivity. The bulk of the radioactivity is in HLW and SNF.

### 2.2.4.2 Transportation Regulations

Shipment of hazardous materials is regulated by the U.S. Department of Transportation (DOT). The DOT regulations for shipping hazardous materials can be found in the Hazardous Material Regulations (49 CFR 106-180), the Federal Motor Carrier Safety Regulations (49 CFR 390-397), and NRC regulations for Packaging and Transportation of Radioactive Material (10 CFR 71). Other regulations and requirements for the shipment of radioactive materials can be found in DOE's Radioactive Material Transportation Practices (DOE 2002b).

These regulations address many specific subjects including the following:

- shipper and carrier responsibilities
- planning information

---

(a) For the purposes of this transportation discussion, hazardous materials include items that present chemical hazards, radioactive hazards, and physical hazards (e.g., compressed gases).

(b) Radioactive materials include radioactive waste.

- routing and route selection
- notifications
- shipping papers
- driver qualifications and training
- vehicles and required equipment
- equipment inspections
- labeling (information on containers)
- placarding (information on the shipping vehicle)
- emergency planning
- emergency notification
- emergency response
- security.

States have also established regulations consistent with DOT regulation. These regulations vary from state to state and typically address permitting, licensing, notification, determination of routes, financial liability, and inspection. Many states require transportation permits for radioactive materials. Some examples of state regulations can be found in:

- Oregon Administrative Rule 740-100, Vehicles: Driver: Equipment: Equipment Required and Condition of Vehicles (OAR 740-100)
- Oregon Administrative Rule 740-110, Transportation of Hazardous Materials (OAR 740-110)
- WAC 246-231, Packaging and Transportation of Radioactive Materials
- WAC 446-50, Transportation of Hazardous Materials.

**Packaging** – The type of package required depends, in part, on the total quantity of radioactivity, the form of the materials, and the concentration of radioactivity. DOE is responsible for determining the appropriate container for the material it is transporting. DOE ensures that each package containing hazardous materials meets DOT regulations for design, material, manufacturing methods, minimum thickness, tolerance, and testing.

**Labeling and Placarding** – Labels are required on each container to indicate the type of hazardous material in the container. Placards are used on vehicles transporting hazardous materials to indicate the type of hazardous material being transported. Labels and placards are used, in part, to assist emergency responders in case of an accident.

**Driver Qualifications** – Drivers of all hazardous materials, including radioactive materials, must be trained in accordance with DOT regulations. Most radioactive waste shipments require specific driver training on emergency response procedures appropriate for the materials being carried.

**Routing** – In general, the carrier selects the shipping routes for highway shipments of most hazardous materials in accordance with DOT regulations. Routes are selected to minimize risk with consideration to such factors as distance of shipment, accident rates, time in transit, population density, time of day, and day of the week. Most radioactive waste is transported along the interstate highway system.

**Notification** – DOE notifies affected states regarding shipments of spent nuclear fuel, HLW, and TRU waste. States are generally not notified about shipments of LLW and MLLW. DOE does not notify states about shipments of classified materials. When notifications are made to states, they are usually also made to affected tribal authorities.

**Emergency Preparedness** – Local, state, tribal, and federal governments and carriers all have responsibility for preparing for and responding to transportation emergencies.

Local or tribal personnel typically are the first responders and incident commanders for offsite transportation accidents. The *Emergency Response Guidebook* (DOT 2000) provides information to assist potential first responders to the scene of a transportation accident involving hazardous materials, including radioactive waste. Although many local jurisdictions have special hazardous material response units, most seek state or federal technical assistance during radiological incidents.

State and tribal governments have primary responsibility for the health and welfare of their citizens and therefore have an interest in ensuring the safety of shipments of hazardous materials, including DOE-owned materials, within their boundaries. Some states maintain specialized emergency response units capable of responding to radioactive material incidents in support of local authorities.

The Federal Emergency Management Agency (FEMA) is responsible for the federal government's emergency response activities. These activities are coordinated through a Federal Radiological Emergency Response Plan developed by FEMA and 11 other federal agencies. FEMA also provides assistance and evaluates state and local preparedness for radiological emergencies.

DOT has established requirements for reporting transportation accidents involving radioactive materials and has a comprehensive training program on handling emergencies involving radioactive materials shipments.

Carriers are required to notify the National Response Center (operated by the U.S. Coast Guard) of all releases of hazardous substances that exceed reportable quantities or levels of concern. Certain transportation incidents involving hazardous materials must also be reported to the National Response Center immediately including those where

- a person is killed
- a person receives injuries that require hospitalization
- property damage exceeds \$50,000
- radioactive materials are released
- major roads are closed.

The DOE Manual (DOE 2002b) expands these criteria and requires notification to the states.

DOE operates a Radiological Assistance Program (RAP) with eight Regional Coordinating Offices staffed with experts available for immediate assistance in offsite radiological monitoring and assessment. DOE RAP teams assist state, local, and tribal officials in identifying the material and monitoring to determine if there is a release and with general support.

Consistent with the DOE Manual (DOE 2002b), DOE has developed the Transportation Emergency Preparedness Program to assist federal, state, tribal, and local authorities to prepare for transportation accidents involving radioactive materials. That assistance includes planning for emergencies as well as training for emergencies. For example, through education programs offered to state and tribal organizations, over 17,000 emergency response personnel in twenty states have been trained to respond to accidents involving radioactive material (Westinghouse 2001). See <http://www.em.doe.gov/otem> for additional information about TEPP.

Like private-sector shippers, DOE must provide emergency response information required on shipping papers, including a 24-hour emergency telephone number. Shippers have overall responsibility for providing adequate technical assistance for emergency response.

Carriers are required to provide emergency planning, emergency response assistance, liability coverage, and site cleanup and restoration. DOE's policy is to respond to requests for technical advice with appropriate information and resources.

Specific information regarding local emergency preparedness can be found through Local Emergency Planning Committees (LEPCs) or State Emergency Response Commissions (SERCs).

## **2.2.5 Pollution Prevention/Waste Minimization**

Consistent with the requirements and guidance of several laws and executive orders, including the Pollution Prevention Act of 1990 (42 USC 13101), DOE performs pollution prevention and waste minimization activities in the work it does. Pollution prevention is defined as the use of materials, processes, and practices that reduce or eliminate the generation and release of pollutants, contaminants, hazardous substances, and wastes into land, water, and air. Pollution prevention includes practices that reduce the use of hazardous materials, energy, water, and other resources along with practices that protect natural resources through conservation or more efficient use. Within DOE, pollution prevention includes all aspects of source reduction as defined by the EPA, and incorporates waste minimization by expanding beyond the EPA definition of pollution prevention to include recycling.

Pollution prevention is achieved through:

- equipment or technology selection or modification, process or procedure modification, reformulation or redesign of products, substitution of raw material, waste segregation, and improvements in housekeeping, maintenance, training or inventory control



The DOE Manual (DOE 2002b) expands these criteria and requires notification to the states.

DOE operates a Radiological Assistance Program (RAP) with eight Regional Coordinating Offices staffed with experts available for immediate assistance in offsite radiological monitoring and assessment. DOE RAP teams assist state, local, and tribal officials in identifying the material and monitoring to determine if there is a release and with general support.

Consistent with the DOE Manual (DOE 2002b), DOE has developed the Transportation Emergency Preparedness Program to assist federal, state, tribal, and local authorities to prepare for transportation accidents involving radioactive materials. That assistance includes planning for emergencies as well as training for emergencies. For example, through education programs offered to state and tribal organizations, over 17,000 emergency response personnel in twenty states have been trained to respond to accidents involving radioactive material (Westinghouse 2001). See <http://www.em.doe.gov/otem> for additional information about TEPP.

Like private-sector shippers, DOE must provide emergency response information required on shipping papers, including a 24-hour emergency telephone number. Shippers have overall responsibility for providing adequate technical assistance for emergency response.

Carriers are required to provide emergency planning, emergency response assistance, liability coverage, and site cleanup and restoration. DOE's policy is to respond to requests for technical advice with appropriate information and resources.

Specific information regarding local emergency preparedness can be found through Local Emergency Planning Committees (LEPCs) or State Emergency Response Commissions (SERCs).

## **2.2.5 Pollution Prevention/Waste Minimization**

Consistent with the requirements and guidance of several laws and executive orders, including the Pollution Prevention Act of 1990 (42 USC 13101), DOE performs pollution prevention and waste minimization activities in the work it does. Pollution prevention is defined as the use of materials, processes, and practices that reduce or eliminate the generation and release of pollutants, contaminants, hazardous substances, and wastes into land, water, and air. Pollution prevention includes practices that reduce the use of hazardous materials, energy, water, and other resources along with practices that protect natural resources through conservation or more efficient use. Within DOE, pollution prevention includes all aspects of source reduction as defined by the EPA, and incorporates waste minimization by expanding beyond the EPA definition of pollution prevention to include recycling.

Pollution prevention is achieved through:

- equipment or technology selection or modification, process or procedure modification, reformulation or redesign of products, substitution of raw material, waste segregation, and improvements in housekeeping, maintenance, training or inventory control

- increased efficiency in the use of raw materials, energy, water, or other resources
- recycling to reduce the amount of waste and pollutants destined for release, treatment, storage, and disposal.

Pollution prevention is applied to all DOE pollution-generating activities including:

- manufacturing and production operations
- facility operations, maintenance, and transportation
- laboratory research
- research, development, and demonstration,
- weapons dismantlement
- stabilization, deactivation, and decommissioning
- legacy waste and contaminated site cleanup.

## **2.2.6 Decontamination and Decommissioning of Hanford Facilities**

Decontamination is the removal, by chemical or physical methods, of radioactive or hazardous materials from internal and external surfaces of components, systems and structures in a nuclear facility. It is usually the first step toward decommissioning. Decommissioning of a nuclear facility can be defined as the measures taken at the end of the facility's lifetime to assure protection of public health and safety and the environment. Such measures can involve protective storage, entombment, or removal. For protective storage, the facility is left intact after removal of most of the radioactive materials and the appropriate security controls are established to assure public health and safety. Entombment consists of removing radioactive liquids and wastes, sealing all remaining radioactivity within the facility, and establishing appropriate security controls to assure public health and safety. For the removal option, all radioactive materials are removed from the site and the facility is refitted for other use or completely dismantled.

## **2.2.7 Long-Term Stewardship**

Cleanup plans and decisions strive to achieve an appropriate balance between contaminant reduction, use of engineered barriers to isolate residual contaminants and retard their migration, and reliance on institutional controls. Decisions are influenced by several factors:

- risks to members of the public, workers, and the environment
- legal and regulatory requirements
- technical and institutional capabilities and limitations
- current state of scientific knowledge
- values and preferences of interested and affected parties
- costs and related budgetary considerations
- impacts on, and activities at, other sites.

Reliance on institutional controls after contaminants have been reduced and engineered barriers have been put in place is referred to as long-term stewardship. Specific long-term stewardship activities depend on the specific hazards that remain and how those hazards are being controlled. Long-term stewardship activities are intended to continue isolating hazards from people and the environment. Specific long-term stewardship activities can include:

- monitoring to verify the integrity of caps placed over disposal sites
- maintaining caps to ensure their continued integrity
- monitoring groundwater and/or the vadose zone to determine whether systems that contain hazardous materials are performing as expected
- monitoring for surface contamination
- monitoring animals, plants, and the ecosystem
- performing groundwater pump-and-treat operations
- installing and maintaining fences and other barriers
- posting warning signs
- establishing easements and deed restrictions
- establishing zoning and land use restrictions
- maintaining records on clean up activities, remaining hazards, and locations of the hazards
- providing funding and infrastructure (e.g., utilities, roads, communications systems) necessary to support long-term stewardship activities.

DOE does not rely solely on long-term stewardship to protect people and the environment. As indicated in the DOE-sponsored report *Long-Term Institutional Management of U. S. Department of Energy Legacy Waste Sites* (National Research Council 2000), “contaminant reduction is preferred to contaminant isolation and the imposition of stewardship measures.” Contaminant reduction is a large part of the ongoing cleanup efforts at Hanford. The long-term stewardship plan for the Hanford Site was approved in August 2003 (DOE-RL 2003).

## 2.3 References

10 CFR 61. “Licensing Requirements for Land Disposal of Radioactive Waste.” Code of Federal Regulations. Online at: [http://www.access.gpo.gov/nara/cfr/waisidx\\_01/10cfr61\\_01.html](http://www.access.gpo.gov/nara/cfr/waisidx_01/10cfr61_01.html)

10 CFR 71. “Packaging and Transportation of Radioactive Material.” Code of Federal Regulations. Online at: [http://www.access.gpo.gov/nara/cfr/waisidx\\_01/10cfr71\\_01.html](http://www.access.gpo.gov/nara/cfr/waisidx_01/10cfr71_01.html)

10 CFR 962. “Byproduct Material.” Code of Federal Regulations. Online at: [http://www.access.gpo.gov/nara/cfr/waisidx\\_02/10cfr962\\_02.html](http://www.access.gpo.gov/nara/cfr/waisidx_02/10cfr962_02.html)

40 CFR 761. “Polychlorinated Biphenyls (PCBs) Manufacturing, Processing, Distribution In Commerce, and Use Prohibitions.” Code of Federal Regulations. Online at: [http://www.access.gpo.gov/nara/cfr/waisidx\\_01/40cfr761\\_01.html](http://www.access.gpo.gov/nara/cfr/waisidx_01/40cfr761_01.html)

- increased efficiency in the use of raw materials, energy, water, or other resources
- recycling to reduce the amount of waste and pollutants destined for release, treatment, storage, and disposal.

Pollution prevention is applied to all DOE pollution-generating activities including:

- manufacturing and production operations
- facility operations, maintenance, and transportation
- laboratory research
- research, development, and demonstration,
- weapons dismantlement
- stabilization, deactivation, and decommissioning
- legacy waste and contaminated site cleanup.

## **2.2.6 Decontamination and Decommissioning of Hanford Facilities**

Decontamination is the removal, by chemical or physical methods, of radioactive or hazardous materials from internal and external surfaces of components, systems and structures in a nuclear facility. It is usually the first step toward decommissioning. Decommissioning of a nuclear facility can be defined as the measures taken at the end of the facility's lifetime to assure protection of public health and safety and the environment. Such measures can involve protective storage, entombment, or removal. For protective storage, the facility is left intact after removal of most of the radioactive materials and the appropriate security controls are established to assure public health and safety. Entombment consists of removing radioactive liquids and wastes, sealing all remaining radioactivity within the facility, and establishing appropriate security controls to assure public health and safety. For the removal option, all radioactive materials are removed from the site and the facility is refitted for other use or completely dismantled.

## **2.2.7 Long-Term Stewardship**

Cleanup plans and decisions strive to achieve an appropriate balance between contaminant reduction, use of engineered barriers to isolate residual contaminants and retard their migration, and reliance on institutional controls. Decisions are influenced by several factors:

- risks to members of the public, workers, and the environment
- legal and regulatory requirements
- technical and institutional capabilities and limitations
- current state of scientific knowledge
- values and preferences of interested and affected parties
- costs and related budgetary considerations
- impacts on, and activities at, other sites.

- increased efficiency in the use of raw materials, energy, water, or other resources
- recycling to reduce the amount of waste and pollutants destined for release, treatment, storage, and disposal.

Pollution prevention is applied to all DOE pollution-generating activities including:

- manufacturing and production operations
- facility operations, maintenance, and transportation
- laboratory research
- research, development, and demonstration,
- weapons dismantlement
- stabilization, deactivation, and decommissioning
- legacy waste and contaminated site cleanup.

## **2.2.6 Decontamination and Decommissioning of Hanford Facilities**

Decontamination is the removal, by chemical or physical methods, of radioactive or hazardous materials from internal and external surfaces of components, systems and structures in a nuclear facility. It is usually the first step toward decommissioning. Decommissioning of a nuclear facility can be defined as the measures taken at the end of the facility's lifetime to assure protection of public health and safety and the environment. Such measures can involve protective storage, entombment, or removal. For protective storage, the facility is left intact after removal of most of the radioactive materials and the appropriate security controls are established to assure public health and safety. Entombment consists of removing radioactive liquids and wastes, sealing all remaining radioactivity within the facility, and establishing appropriate security controls to assure public health and safety. For the removal option, all radioactive materials are removed from the site and the facility is refitted for other use or completely dismantled.

## **2.2.7 Long-Term Stewardship**

Cleanup plans and decisions strive to achieve an appropriate balance between contaminant reduction, use of engineered barriers to isolate residual contaminants and retard their migration, and reliance on institutional controls. Decisions are influenced by several factors:

- risks to members of the public, workers, and the environment
- legal and regulatory requirements
- technical and institutional capabilities and limitations
- current state of scientific knowledge
- values and preferences of interested and affected parties
- costs and related budgetary considerations
- impacts on, and activities at, other sites.

Reliance on institutional controls after contaminants have been reduced and engineered barriers have been put in place is referred to as long-term stewardship. Specific long-term stewardship activities depend on the specific hazards that remain and how those hazards are being controlled. Long-term stewardship activities are intended to continue isolating hazards from people and the environment. Specific long-term stewardship activities can include:

- monitoring to verify the integrity of caps placed over disposal sites
- maintaining caps to ensure their continued integrity
- monitoring groundwater and/or the vadose zone to determine whether systems that contain hazardous materials are performing as expected
- monitoring for surface contamination
- monitoring animals, plants, and the ecosystem
- performing groundwater pump-and-treat operations
- installing and maintaining fences and other barriers
- posting warning signs
- establishing easements and deed restrictions
- establishing zoning and land use restrictions
- maintaining records on clean up activities, remaining hazards, and locations of the hazards
- providing funding and infrastructure (e.g., utilities, roads, communications systems) necessary to support long-term stewardship activities.

DOE does not rely solely on long-term stewardship to protect people and the environment. As indicated in the DOE-sponsored report *Long-Term Institutional Management of U. S. Department of Energy Legacy Waste Sites* (National Research Council 2000), “contaminant reduction is preferred to contaminant isolation and the imposition of stewardship measures.” Contaminant reduction is a large part of the ongoing cleanup efforts at Hanford. The long-term stewardship plan for the Hanford Site was approved in August 2003 (DOE-RL 2003).

## 2.3 References

10 CFR 61. “Licensing Requirements for Land Disposal of Radioactive Waste.” Code of Federal Regulations. Online at: [http://www.access.gpo.gov/nara/cfr/waisidx\\_01/10cfr61\\_01.html](http://www.access.gpo.gov/nara/cfr/waisidx_01/10cfr61_01.html)

10 CFR 71. “Packaging and Transportation of Radioactive Material.” Code of Federal Regulations. Online at: [http://www.access.gpo.gov/nara/cfr/waisidx\\_01/10cfr71\\_01.html](http://www.access.gpo.gov/nara/cfr/waisidx_01/10cfr71_01.html)

10 CFR 962. “Byproduct Material.” Code of Federal Regulations. Online at: [http://www.access.gpo.gov/nara/cfr/waisidx\\_02/10cfr962\\_02.html](http://www.access.gpo.gov/nara/cfr/waisidx_02/10cfr962_02.html)

40 CFR 761. “Polychlorinated Biphenyls (PCBs) Manufacturing, Processing, Distribution In Commerce, and Use Prohibitions.” Code of Federal Regulations. Online at: [http://www.access.gpo.gov/nara/cfr/waisidx\\_01/40cfr761\\_01.html](http://www.access.gpo.gov/nara/cfr/waisidx_01/40cfr761_01.html)

Reliance on institutional controls after contaminants have been reduced and engineered barriers have been put in place is referred to as long-term stewardship. Specific long-term stewardship activities depend on the specific hazards that remain and how those hazards are being controlled. Long-term stewardship activities are intended to continue isolating hazards from people and the environment. Specific long-term stewardship activities can include:

- monitoring to verify the integrity of caps placed over disposal sites
- maintaining caps to ensure their continued integrity
- monitoring groundwater and/or the vadose zone to determine whether systems that contain hazardous materials are performing as expected
- monitoring for surface contamination
- monitoring animals, plants, and the ecosystem
- performing groundwater pump-and-treat operations
- installing and maintaining fences and other barriers
- posting warning signs
- establishing easements and deed restrictions
- establishing zoning and land use restrictions
- maintaining records on clean up activities, remaining hazards, and locations of the hazards
- providing funding and infrastructure (e.g., utilities, roads, communications systems) necessary to support long-term stewardship activities.

DOE does not rely solely on long-term stewardship to protect people and the environment. As indicated in the DOE-sponsored report *Long-Term Institutional Management of U. S. Department of Energy Legacy Waste Sites* (National Research Council 2000), “contaminant reduction is preferred to contaminant isolation and the imposition of stewardship measures.” Contaminant reduction is a large part of the ongoing cleanup efforts at Hanford. The long-term stewardship plan for the Hanford Site was approved in August 2003 (DOE-RL 2003).

## 2.3 References

10 CFR 61. “Licensing Requirements for Land Disposal of Radioactive Waste.” Code of Federal Regulations. Online at: [http://www.access.gpo.gov/nara/cfr/waisidx\\_01/10cfr61\\_01.html](http://www.access.gpo.gov/nara/cfr/waisidx_01/10cfr61_01.html)

10 CFR 71. “Packaging and Transportation of Radioactive Material.” Code of Federal Regulations. Online at: [http://www.access.gpo.gov/nara/cfr/waisidx\\_01/10cfr71\\_01.html](http://www.access.gpo.gov/nara/cfr/waisidx_01/10cfr71_01.html)

10 CFR 962. “Byproduct Material.” Code of Federal Regulations. Online at: [http://www.access.gpo.gov/nara/cfr/waisidx\\_02/10cfr962\\_02.html](http://www.access.gpo.gov/nara/cfr/waisidx_02/10cfr962_02.html)

40 CFR 761. “Polychlorinated Biphenyls (PCBs) Manufacturing, Processing, Distribution In Commerce, and Use Prohibitions.” Code of Federal Regulations. Online at: [http://www.access.gpo.gov/nara/cfr/waisidx\\_01/40cfr761\\_01.html](http://www.access.gpo.gov/nara/cfr/waisidx_01/40cfr761_01.html)

49 CFR 106-180. "Subtitle B—Other Regulations Relating to Transportation. Chapter I. Research and Special Programs Administration." Code of Federal Regulations. Online at: [http://www.access.gpo.gov/nara/cfr/waisidx\\_02/49cfrv2\\_02.html](http://www.access.gpo.gov/nara/cfr/waisidx_02/49cfrv2_02.html)

49 CFR 390-397. "Federal Motor Carrier Safety Regulations." Online at: [http://www.access.gpo.gov/nara/cfr/waisidx\\_01/49cfr390\\_01.html](http://www.access.gpo.gov/nara/cfr/waisidx_01/49cfr390_01.html)

68 FR 1052. "Notice of Intent To Prepare an Environmental Impact Statement for Retrieval, Treatment, and Disposal of Tank Waste and Closure of Single-Shell Tanks at the Hanford Site, Richland, WA." *Federal Register* (January 8, 2003).

15 USC 2601 et seq. Toxic Substances Control Act (TSCA). Online at: <http://www4.law.cornell.edu/uscode/15/2601.html>

42 USC 6901 et seq. Resource Conservation and Recovery Act (RCRA) of 1976. Online at: <http://www4.law.cornell.edu/uscode/42/6901.html>

42 USC 13101. Pollution Prevention Act of 1990. Online at: <http://www4.law.cornell.edu>

Anderson, B. C., J. D. Anderson, J. A. Demiter, D. R. Duncan, and D. C. McCann. 1990. *Contact-Handled Transuranic Waste Characterization Based on Existing Records*. WHC-EP-0225, Westinghouse Hanford Company, Richland, Washington.

Aromi, E. S. and R. D. Freeberg. 2002. *Request for CHG Support Concerning Immobilized Low-Activity Waste Choices*. CHG-0203620R2, CH2M Hill Hanford Group, Richland, Washington.

Burbank, D. A. 2002. *Conceptual Design Report for Immobilized Low-Activity Waste Disposal Facility, Project W-520, Rev 0*. RPP-7908, Rev. 0A, CH2M Hill Hanford Group, Richland, Washington.

DOE. 1987. *Final Environmental Impact Statement for Disposal of Hanford Defense High-Level, Transuranic, and Tank Wastes*. DOE/EIS-0113, U.S. Department of Energy, Washington D.C.

DOE. 1998. *Environmental Assessment – Non-Thermal Treatment of Hanford Site Low-Level Mixed Waste*. DOE/EA-1189, U.S. Department of Energy, Richland Operations Office, Richland, Washington. Online at: <http://www.hanford.gov/docs/ea/ea1189/index.html>

DOE. 1999. *Environmental Assessment – Offsite Thermal Treatment of Low-Level Mixed Waste*. DOE/EA-1135, U.S. Department of Energy, Richland Operations Office, Richland, Washington. Online at: <http://www.hanford.gov/docs/ea/ea1135/FONSI.html>

DOE. 2001a. *Environmental Assessment – K Basins Sludge Storage at 221-T Building, Hanford Site, Richland, Washington*. DOE/EA-1369, U.S. Department of Energy, Richland, Washington. Online at <http://www.hanford.gov/docs/ea/ea1369/ea-1369.pdf>



DOE. 2001b. *Radioactive Waste Management Manual*. DOE Manual 435.1. U.S. Department of Energy, Washington D.C. Online at: <http://www.directives.doe.gov>

DOE. 2001c. *Supplement Analysis for the Tank Waste Remediation System*. DOE/EIS-0189-SA3, U.S. Department of Energy, Richland Operations Office, Richland, Washington.

DOE. 2002a. *Environmental Assessment – Transuranic Waste Retrieval from the 218-W-4B and 218-W-4C Low-Level Burial Grounds, Hanford Site, Richland, Washington*. DOE/EA-1405, U.S. Department of Energy, Richland Operations Office, Richland, Washington. Online at: <http://www.hanford.gov/docs/ea/ea1405/ea1405.pdf>

DOE. 2002b. *Radioactive Material Transportation Practices Manual for Use with DOE O 460.2*. DOE Manual 460.2-1, U.S. Department of Energy, Washington, D.C. Online at: <http://www.directives.doe.gov/pdfs/doe/doetext/neword/460/m4602-1.pdf>

DOE and Ecology. 1996. *Tank Waste Remediation System, Hanford Site, Richland, Washington, Final Environmental Impact Statement*. DOE/EIS-0189, U.S. Department of Energy, Richland Operations Office, Richland, Washington and Washington State Department of Ecology, Olympia, Washington.

DOE-NTP. 2002. *National TRU Waste Management Plan*. DOE/NTP-96-1204, Rev. 3, U.S. Department of Energy, Carlsbad Field Office, Carlsbad, New Mexico. Online at: <http://www.wipp.carlsbad.nm.us/library/ntwmp/rev3/Cover.pdf>

DOE-RL. 1997. *Hanford Facility Dangerous Waste Permit Application, Low-Level Burial Grounds*. DOE/RL-88-20, Rev. 1, U.S. Department of Energy, Richland Operations Office, Richland, Washington.

DOE-RL. 2003. *Hanford Long-Term Stewardship Program and Transition: Preparing for Environmental Management Cleanup Completion*. DOE/RL-2003-39, Rev. 0, U.S. Department of Energy, Richland, Washington.

DOE-WIPP. 2002. *Contact-handled Transuranic Waste Acceptance Criteria for the Waste Isolation Pilot Plant*. DOE/WIPP-02-3122, Revision 0.1. U.S. Department of Energy, Waste Isolation Pilot Plant, Carlsbad, New Mexico. Online at: <http://www.wipp.ws/library/wac/CH-WACRev0.1.pdf>

DOT. 1998. *Hazardous Materials Shipments*. U.S. Department of Transportation, Office of Hazardous Materials Safety, Research and Special Programs Administration, Washington, D.C. Online at: <http://hazmat.dot.gov/pubtrain/hmship.htm>

DOT. 2000. United States: Dept. of Transportation, Research and Special Programs Administration; Canada: Transport Dangerous Goods Directorate; Mexico: Secretaría de Comunicaciones y Transportes. *2000 Emergency Response Guidebook: a guidebook for first responders during the initial phase of a hazardous materials incident* [Washington, D.C.]. U.S. Dept. of Transportation, Research and Special Programs Administration.

EPA. 1989. *Technical Guidance Document: Final Covers on Hazardous Waste Landfills and Surface Impoundments*. EPA/530/SW-89/047, Environmental Protection Agency, Office of Solid Waste, Washington, D.C.

FH. 2003. *Hanford Site Solid Waste Acceptance Criteria*. HNF-EP-0063, Rev. 9, Fluor Hanford, Inc., Richland, Washington. Online at: <http://www.hanford.gov/wastemgt/wac/acceptcriteria.cfm>

FH. 2004. *Hanford Site Solid Waste Management Environmental Impact Statement Technical Information Document*. HNF-4755, Rev. 2, Fluor Hanford, Inc., Richland, Washington.

National Research Council. 2000. *Long-Term Institutional Management of U. S. Department of Energy Legacy Waste Sites*. Prepared by Committee on the Remediation of Buried and Tank Wastes, Board on Radioactive Waste Management, Commission on Geosciences, Environment and Resources, National Research Council, National Academy Press, Washington, D.C. Online at: <http://www.nap.edu/books/0309071860/html>

NEI. 2003. *Transportation of Radioactive Materials—Safety in Motion*. Nuclear Energy Institute, Washington, D.C. Online at: <http://www.nei.org/index.asp?catnum=3&catid=462>.

OAR 740-100. “Vehicles: Driver: Equipment: Equipment Required and Condition of Vehicles.” Oregon Administrative Rule 740-100, Salem, Oregon. Online at: [http://www.sos.state.or.us/archives/rules/OARS\\_700/OAR\\_740/740\\_100.html](http://www.sos.state.or.us/archives/rules/OARS_700/OAR_740/740_100.html)

OAR 740-110. “Transportation of Hazardous Materials.” Oregon Administrative Rule 740-110, Salem, Oregon. Online at: [http://arcweb.sos.state.or.us/rules/OARS\\_700/OAR\\_740/740\\_110.html](http://arcweb.sos.state.or.us/rules/OARS_700/OAR_740/740_110.html)

RCW 70.105. “*Hazardous Waste Management Act*.” Revised Code of Washington. Olympia, Washington. Online at: <http://www.ecy.wa.gov/laws-rules/index.html>

Tisinger, L. G. and J. P. Giroud. 1993. The Durability of HDPE Geomembranes. *Geotechnical Fabrics Report*, 11(6): 4-8.

WAC 173-303. “Dangerous Waste Regulations.” Washington Administrative Code, Olympia, Washington. Online at: <http://www.ecy.wa.gov/laws-rules/index.html>

WAC 246-231. “Packaging and Transportation of Radioactive Materials.” Washington Administrative Code, Olympia, Washington. Online at: <http://www.leg.wa.gov/wac/index.cfm?fuseaction=chapterdigest&chapter=246-231>

WAC 446-50. “Transportation of Hazardous Materials.” Washington Administrative Code, Olympia, Washington. Online at: <http://www.leg.wa.gov/wac/index.cfm?fuseaction=chapterdigest&chapter=446-50>

Westinghouse. 2001. "WIPP Instructors to Provide Specialized Training for Indiana Emergency Response Professionals." *Westinghouse News*, dated January 25, 2001. Online at: <http://www.wipp.carlsbad.nm.us/pr/2001/INSTEP.pdf>

## 3.0 Description and Comparison of Alternatives

This section describes the alternatives for storage, treatment, and disposal that are analyzed in this *Hanford Site Solid (Radioactive and Hazardous) Waste Program Environmental Impact Statement* (HSW EIS) as well as alternatives eliminated from detailed analysis. As required by the Council on Environmental Quality (CEQ) regulations implementing the National Environmental Policy Act (NEPA) of 1969 (40 CFR 1500-1508), a No Action Alternative is also included.

The waste streams and facilities that are considered in this EIS were identified and described in Sections 2.1 and 2.2. Section 3.1 describes the alternatives and the development and selection of alternative groups that are analyzed in detail. Section 3.2 identifies alternatives that were not analyzed in detail. The three waste volumes, Hanford Only, Lower Bound, and Upper Bound are presented as alternative waste volume scenarios in Section 3.3. A comparison of the environmental impacts associated with each of the alternative groups is contained in Section 3.4. The major uncertainties in the EIS analysis are identified in Section 3.5. A summary of the estimated costs for the alternative groups is included in Section 3.6. The U.S. Department of Energy (DOE) preferred alternative is discussed in Section 3.7. Detailed descriptions of alternatives, assumptions, waste volumes, and waste stream flowsheets are provided in Appendixes B and C. Section 2 and the Technical Information Document (FH 2004) to support this EIS should be reviewed when additional information on a facility or waste stream is desired.

### 3.1 Alternatives Considered in Detail and Their Development

The CEQ regulations direct all federal agencies to use the NEPA process to identify and assess the reasonable alternatives to proposed actions that would avoid or minimize adverse effects of the proposed action on the quality of the human environment. Related CEQ guidance in the “Forty Most Asked Questions...” states that “When there are potentially a very large number of alternatives, only a reasonable number of examples, covering the full spectrum of alternatives, must be analyzed and compared in the EIS” (46 FR 18026). In considering the alternatives for this EIS it was quickly recognized that there is a very large number of combinations of the various waste streams, potential waste volumes and individual options for storage, treatment, and disposal. Therefore, the alternatives developed for this EIS were selected to represent a full spectrum of reasonable alternatives.

The individual alternatives for the proposed actions are shown in Figure 3.1. The alternatives are first subdivided into three types of action (storage, treatment, and disposal), and then further subdivided into specific alternatives for each of the waste types (LLW, MLLW, TRU waste, ILAW, and melters) as appropriate. It should be noted that no storage or treatment alternatives are shown for ILAW and melters because those activities have been, or are being, evaluated in separate NEPA reviews (DOE and Ecology 1996; 68 FR 1052). Also, no disposal alternatives are shown for TRU waste because DOE previously decided to dispose of TRU waste at the Waste Isolation Pilot Plant (WIPP; DOE 1997b). WIPP alternatives and activities are also not within the scope of this EIS. Disposal alternatives for each of the waste

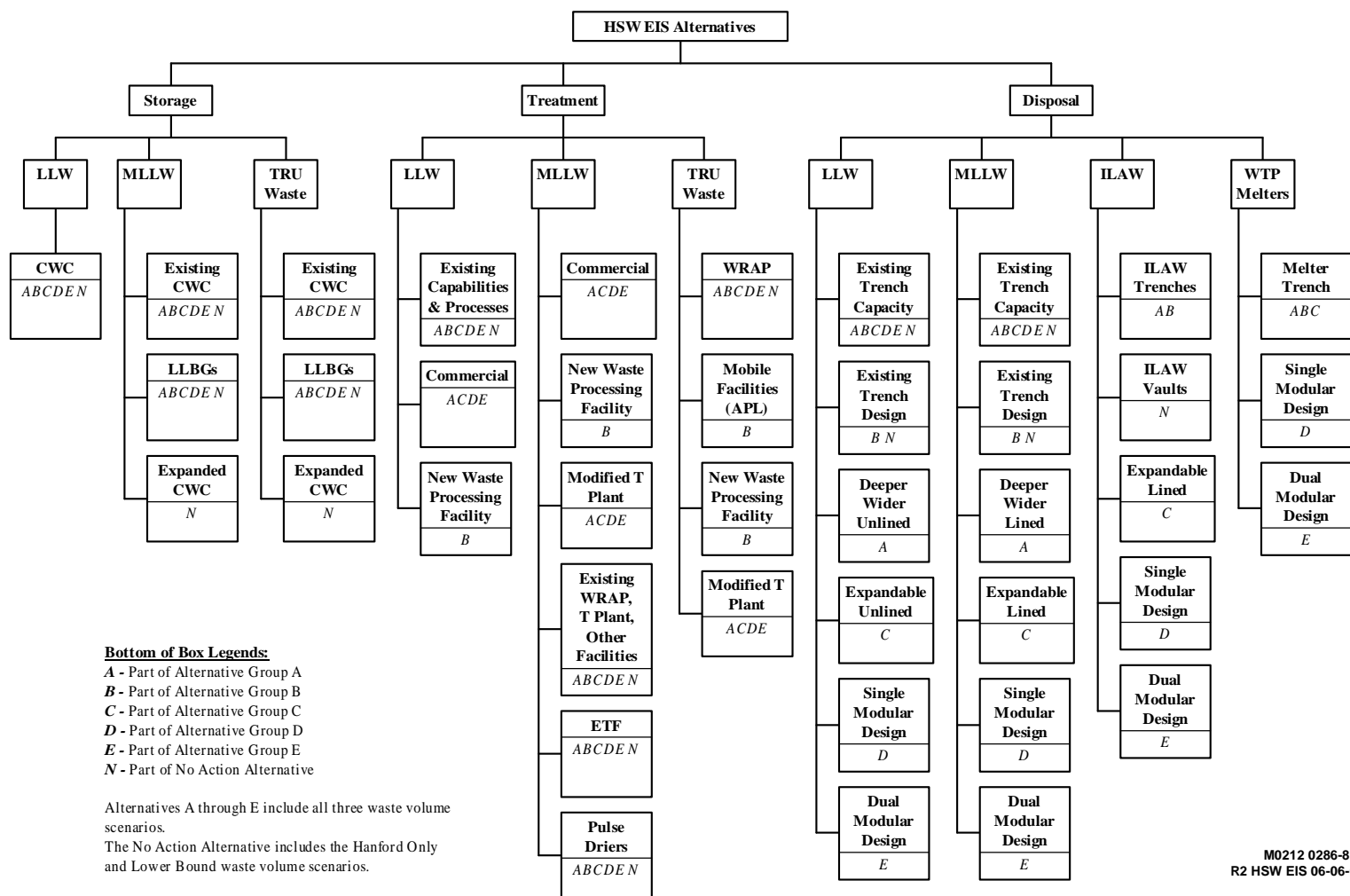


Figure 3.1. Options for HSW EIS Alternatives

types consider both independent disposal facilities for a single waste type as well as modular combined-use disposal facilities that would contain either two or four of the waste types.

It should be noted that Figure 3.1 has been simplified by considering actions where possible at the four waste type levels, rather than the 21 waste stream levels (see Figure 2.1 in Section 2). In the descriptions of the alternatives, specific actions for individual waste streams are also discussed. With the primary alternatives in Figure 3.1, alternative groups can be defined from the potential combinations of storage, treatment, and disposal alternatives for each of the waste types. However, these groupings for purposes of analysis are not intended to be restrictive in the final selection and implementation of the EIS alternatives. DOE may ultimately develop its final decisions based on a different combination of specific actions for individual waste streams.

For the analysis of potential actions, DOE has defined six representative alternatives groups from among the many possible combinations. It is necessary in the development of an alternative to specify options for each of the waste types and to include a full set of treatment, storage, and disposal activities. For the purposes of this EIS, each selected set of activities is called an alternative group, since it consists of a group of alternatives for various waste types and activities. The use of groups in the analysis is necessary because some facilities can process more than one waste type, and some impacts are only meaningful when assessed using a complete set of alternatives. The alternative groups have been identified as A, B, C, D, E, and No Action (N). Key characteristics of each of the groups are shown in the adjacent text box. Each of the alternative groups is discussed in greater detail in subsequent sections. The individual alternative actions that are used in each of the alternative groups can be noted by the corresponding letter in italics at the bottom of each box. Note that some individual alternatives are used in all alternative groups, whereas in other cases an alternative is only used in one alternative group. For Alternative Groups D and E, different potential disposal facility locations within the Hanford Central Plateau are under consideration and have been evaluated in Section 5. The specifics for the locations are discussed in their respective sections (3.1.5 and 3.1.6). The locations of the major facilities are shown in Figure 3.2.

**Key Characteristics of  
Alternative Groups**

- A – Additional treatment in the modified T Plant and disposal in deeper and wider trenches.
- B – Additional treatment in a new waste processing facility and disposal using existing trench designs.
- C – Additional treatment in the modified T Plant and disposal in a single expandable trench for each waste type.
- D – Additional treatment in the modified T Plant and disposal in a single combined-use facility containing LLW, MLLW, ILAW, and WTP melters.
- E – Additional treatment in the modified T Plant and disposal in two combined-use facilities, one for LLW and MLLW, and the second for ILAW and WTP melters.
- N (No Action) – Continue current practices or implement previous decisions.

Within the EIS, DOE analyzes as many as three alternative waste volume scenarios. The “Hanford Only” waste volume represents waste forecast to be received from Hanford Site generators. The “Lower Bound” waste volume is the current best estimate of the amount DOE could receive from offsite (based on past receipts) combined with the best projection of what might be generated at Hanford. The “Upper Bound” waste volume provides the highest projected offsite waste volume that could be received, along with the best projection of what might be generated at Hanford.

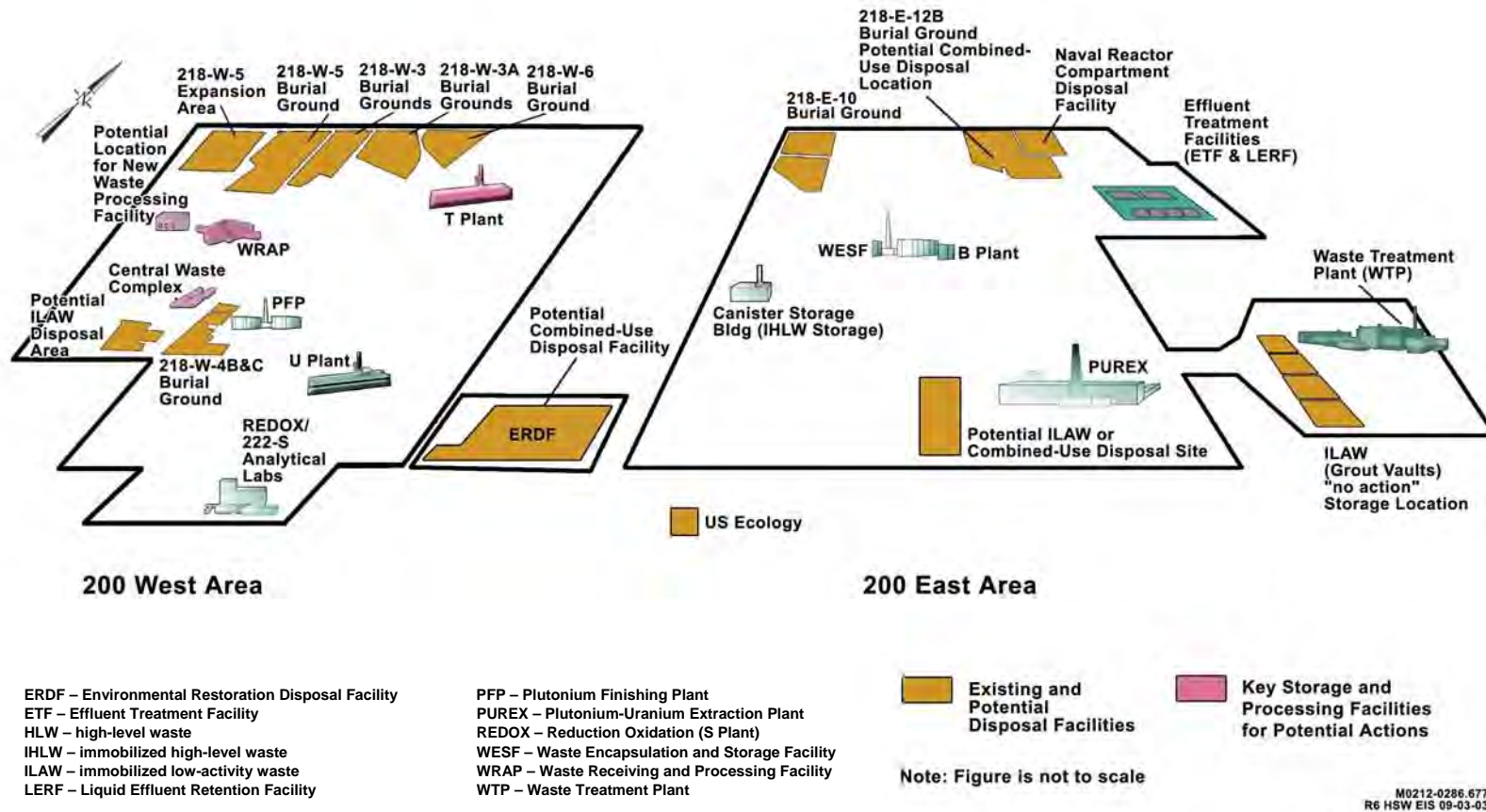


Figure 3.2. Locations of Existing and Potential Processing and Disposal Facilities on the Hanford Site

The Hanford Only waste volume excludes future offsite waste volumes entirely so the incremental impacts of receiving offsite waste could be determined. The three volumes by waste type are illustrated in Figure 3.3.

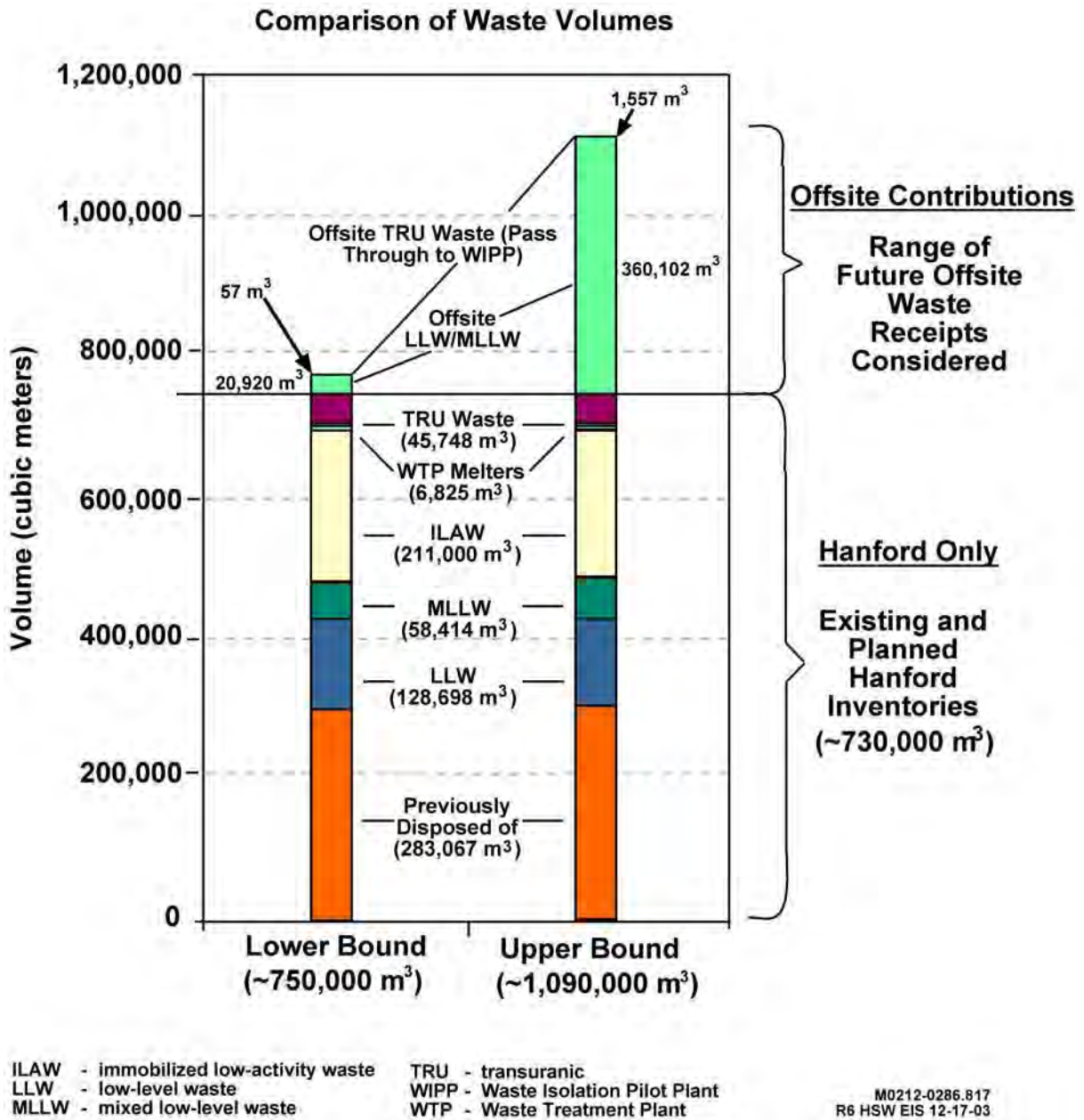


Figure 3.3. Range of Waste Volumes Considered in the HSW EIS



### **3.1.1 No Action Alternative**

The No Action Alternative provides a baseline for comparison of the impacts from the proposed action and alternatives and is consistent with decisions reached under previous NEPA reviews. No Action thus reflects the current status quo and continued operation of existing facilities without conducting additional activities necessary to meet regulatory obligations. The No Action Alternative would only partially meet DOE's obligations under the Hanford TPA and applicable regulatory requirements. As such it represents an analytical construct to meet NEPA requirements rather than an expression of DOE's intended future actions.

Because most activities considered in the HSW EIS are ongoing operations, or have been the subject of previous decisions made under other NEPA reviews, the No Action Alternative consists of implementing the previous NEPA decisions or of continuing current solid waste management practices, consistent with CEQ guidance. The No Action Alternative for disposal of ILAW consists of the preferred alternative described previously in the Tank Waste Remediation System (TWRS) EIS (DOE and Ecology 1996). The No Action Alternative was evaluated using the Hanford Only waste volume and the Lower Bound waste volume. The ILAW volume reflects a different waste form (cullet in canisters) than that assumed for Alternative Groups A through E (monolithic vitrified waste in canisters).

#### **3.1.1.1 Storage**

In the No Action Alternative, additional CWC storage would be needed for waste that could not be treated or disposed of. Hanford's non-conforming LLW would continue to be stored in the CWC. Most MLLW would be stored at CWC due to limited treatment and disposal capacity. Likewise, melters from the WTP would be stored at CWC, because no disposal facility would be available for them. All TRU waste that cannot be processed at WRAP would be stored at CWC or the T Plant Complex. The wastes requiring storage would include non-standard containers, RH TRU waste, and PCB-commingled TRU waste. K Basin sludge would remain in storage at the T Plant Complex. Additional storage space would be constructed at CWC as needed for LLW, MLLW, melters, and TRU waste.

The existing grout vaults would be modified for storage of ILAW until disposal vaults were constructed in accordance with the TWRS EIS ROD.

#### **3.1.1.2 Treatment**

No treatment capability would be available for non-conforming LLW, and for most MLLW. Treatment of solid MLLW would be limited to the existing commercial treatment contracts and the limited existing capacity of WRAP, the T Plant Complex, and other onsite facilities. Leachate from the MLLW trenches would be collected and sent by truck to the 200 East Area Effluent Treatment Facility (ETF) for treatment. After ETF closes, leachate would be treated using a pulse drier. Solids from that treatment would be sent to the MLLW trenches for disposal or to CWC for storage after the trenches are closed. Previously treated MLLW, potentially including MLLW received from offsite generators, would be directly disposed of in the two existing regulatory-compliant (lined) MLLW trenches as long as space is available.

Processing and certification of TRU waste would continue at WRAP, the T Plant Complex, and mobile processing facilities (accelerated process lines, or APLs) to prepare existing stored and newly generated CH TRU waste packaged in standard containers for shipment to WIPP. The EIS analysis assumed that DOE would continue to operate WRAP until 2032 to perform this function. After closure of WRAP, individual generators would be responsible for certifying and shipping their own waste.

Consistent with the TWRS EIS ROD, ILAW would be processed into cullet (granular glass particles similar in size to pea gravel), and placed into containers for onsite storage in modified grout vaults that were constructed in the 1980s.

### **3.1.1.3 Disposal**

LLW would be prepared for disposal to meet the *Hanford Site Solid Waste Acceptance Criteria* (HSSWAC, FH 2003). Cat 1 wastes would be placed directly into the LLBGs. Cat 3 and GTC3 wastes would either be disposed of in high-integrity containers (HICs) or in-trench grouted. DOE would continue the practice of building LLW disposal trenches in the LLBGs using the current trench design (unlined) as additional disposal capacity is needed. DOE would backfill the trenches with soil as their capacity is reached, but the trenches would not be capped.

Disposal of MLLW would occur only in the two existing MLLW trenches. The MLLW trenches would be capped in accordance with regulations after they are filled. An additional 66 new vaults would be constructed for ILAW disposal in the 200 East Area within 3.1 km (1.9 mi) of the existing vaults southwest of PUREX. The new vaults would contain a leachate collection system and would have an array of monitoring wells. All ILAW would be transferred to the new vaults, which would be equipped with a crane to place the containers into specific locations that would be recorded into a registry that includes container serial number, date, and position. An interim barrier containing a surface liner and an interim cover of sand and gravel totaling about 3.3 m (11 ft) thick would be placed over the containers. A regulatory-compliant barrier would be applied at closure.

## **3.1.2 Alternative Group A**

The storage, treatment, and disposal alternatives included in Alternative Group A are described in the following sections.

### **3.1.2.1 Storage**

Most LLW would not be stored, but would be sent directly to the LLBGs. However, some waste would be received and placed into temporary storage in CWC until it could go to WRAP for inspection. After passing inspection it would be sent on to the LLBGs. Non-conforming LLW that cannot go to disposal would be stored in CWC until it could be sent to a treatment facility. No long-term storage of LLW is expected in Alternative Group A.

Historically, MLLW has been stored in CWC and would continue to be stored there until treatment is available. In Alternative Group A, all MLLW would be treated, so no long-term storage would be needed.

TRU waste is currently stored in CWC and in the LLBGs. In Alternative Group A, all of the waste would be sent to onsite processing facilities and then to WIPP, thus eliminating any long-term onsite storage requirement.

WTP waste including the ILAW and melters would be sent directly to their respective disposal facilities. Storage of these wastes is not evaluated in this EIS.

### **3.1.2.2 Treatment**

LLW needs to meet the HSSWAC before it can be disposed at Hanford. Most LLW does not require treatment to meet the HSSWAC. Treatment of LLW for volume reduction is not generally economically beneficial and is therefore not proposed as part of the HSW EIS alternatives. Cat 1 wastes would be placed directly into the LLBG following verification. Cat 3 and GTC3 wastes would continue to be either emplaced in HICs or in-trench grouted. For purposes of analysis, it was assumed nonconforming LLW that could not be treated onsite would be treated in a commercial treatment facility and returned to Hanford for disposal.

At Hanford, most MLLW arrives treated and ready for disposal without further treatment. Other waste streams require treatment in accordance with regulatory requirements to allow the wastes to meet the HSSWAC for onsite disposal. Six MLLW streams are evaluated in this HSW EIS, each of which involves specific treatment standards. DOE would continue to use limited existing treatment capabilities at the T Plant Complex, WRAP, and other onsite facilities as appropriate; however, most MLLW generated at Hanford would require development of new treatment capacity.

Treatment standards for CH Inorganic Solids and Debris specify treatment by macroencapsulation as demonstrated by an existing commercial contract. DOE would continue to use commercial facilities to treat most of Hanford's CH MLLW, with minimal onsite treatment in the modified T Plant Complex. CH Organic Solids and Debris require thermal treatment if such capability is available. Availability of thermal treatment technologies has been limited; however, in this Alternative Group it is assumed that the commercial facilities would become available to treat these wastes. Most Elemental Lead, which would likely be treated by macroencapsulation, and Elemental Mercury wastes, possibly treated by thermal desorption, would be sent to commercial treatment facilities. The Mixed Waste Trench Leachate would be treated in ETF, and pulse driers would be used after ETF closes. Treatment would be the same as in the No Action Alternative; however, the volume would be much higher with additional disposal trenches.

The RH and non-standard Packages of MLLW and TRU waste require new treatment and processing capabilities. In Alternative Group A, operations such as size-reduction and repackaging technologies and RH macroencapsulation capacity would be incorporated into the modified T Plant to process these waste streams.

In Alternative Group A, the CH TRU wastes from trenches, wastes currently stored in CWC, and newly generated TRU wastes in standard packages would be processed in WRAP. DOE would continue to operate WRAP until 2032 to perform this function. After closure of WRAP, individual Hanford generators would be responsible for certifying and shipping their own waste. The RH and non-standard

wastes from trenches and caissons, wastes currently stored in CWC, newly generated wastes, polychlorinated biphenyl (PCB) wastes, and K Basin sludge, would be processed in a modified T Plant using a variety of technologies to package and certify the wastes for WIPP. Mobile processing facilities (APLs) would be used to supplement these existing and planned capabilities to accelerate preparation of TRU waste for shipment to WIPP.

### **3.1.2.3 Disposal**

Alternative Group A would utilize the existing LLW trenches in the LLBG until they have been filled, and then additional disposal trenches would be constructed in the 200 West Area using a deeper, wider trench design to increase the efficiency of the disposal operations and to maintain the current focus of LLW disposal operations in the 200 West Area in accordance with the previous performance assessments for LLW disposal. Unlined deeper and wider trenches would be used after about 2005.

MLLW disposal alternatives would use the existing MLLW trenches until they have been filled and then develop deeper, wider lined trenches in the 200 East Area. Leachate from the 200 East Area disposal facilities would then be sent by truck to the ETF for treatment, and pulse driers would be used thereafter.

TRU waste would be shipped to WIPP.

The ILAW canisters would be placed into a dedicated disposal facility near PUREX in multiple lined trenches.

The large WTP melters would be taken to a dedicated lined trench near PUREX for disposal.

All of the MLLW trenches would be capped when the trenches are filled. Other LLW trenches, ILAW, and melter trenches would be closed at the end of their mission and the disposal facilities would be capped in accordance with applicable regulatory requirements with the Modified RCRA Subtitle C Barrier.

### **3.1.3 Alternative Group B**

Alternative Group B includes activities that maximize onsite treatment of MLLW and non-conforming LLW, and which involve construction of new facilities to treat LLW, MLLW, and TRU waste. Disposal of LLW and MLLW would take place in less efficient trench configurations of existing design. Disposal of WTP melters and ILAW would use the same trench configurations as in Alternative Group A, but would occur in different locations. This combination of alternatives is expected to result in the maximum short- and long-term environmental impacts because it includes more onsite activities and new construction. Alternatives included in Alternative Group B are described as follows.

#### **3.1.3.1 Storage**

The storage alternatives for LLW, MLLW, and TRU waste are the same in Alternative Group B as in Alternative Group A.

### **3.1.3.2 Treatment**

LLW treatment alternatives are the same as in Group A, except for the non-conforming wastes. Those wastes would be sent to an onsite New Waste Processing Facility rather than to a commercial treatment facility.

MLLW treatment would first complete the existing commercial contracts and then utilize the New Waste Processing Facility rather than using additional offsite commercial facility contracts and the modified T Plant as in Alternative Group A. Existing MLLW treatment capabilities at the T Plant Complex, WRAP, and other onsite facilities would continue to be used as appropriate.

TRU waste would be prepared for shipment to WIPP. The New Waste Processing Facility would process RH waste, waste in non-standard containers, and other wastes that would be processed at the modified T Plant under Alternative Group A. WRAP would continue operations as the main processing facility for CH TRU waste in standard containers, and TRU waste processing capacity would be increased by the use of mobile treatment facilities (APLs).

### **3.1.3.3 Disposal**

As in Alternative A, the existing LLW trenches and existing MLLW trenches would first be utilized. Then additional facilities based on the current design for LLW trenches would be built in the 200 West Area. Additional MLLW trenches of the current design would be built in the 200 East Area. Leachate from the 200 East Area disposal facilities would then be sent by truck to the ETF for treatment, and pulse driers would be used thereafter.

The WTP melters would be disposed of in a single expandable lined trench to be built in the 200 East Area LLBGs, and the ILAW would be disposed of in multiple lined trenches to be built in the 200 West Area.

All of the mixed waste trenches would be capped with a Modified RCRA Subtitle C Barrier in accordance with applicable regulatory requirements. The rest of the LLBGs would be capped at closure.

All of the processed and certified TRU waste would be shipped to WIPP.

### **3.1.4 Alternative Group C**

Alternative Group C activities for storage, treatment, and processing of LLW, MLLW, and TRU waste are the same as those considered in Alternative Group A. This group also includes use of existing LLW and MLLW disposal capacity before construction of new disposal facilities and appropriate closure as in Alternative Group A.

Additional disposal alternatives in Alternative Group C include: LLW disposal in the LLBGs in a single expandable unlined trench in the 200 West Area; MLLW disposal in the LLBGs in a single expandable lined trench in the 200 East Area; ILAW disposal in a single expandable lined trench near

PUREX, and melter disposal in a single expandable lined trench also near PUREX. All of the trenches would be capped with a Modified RCRA Subtitle C Barrier at closure in accordance with applicable regulatory requirements.

### **3.1.5 Alternative Group D**

Alternatives for storage, treatment, and processing of LLW, MLLW, and TRU waste are the same as those considered in Alternative Group A. Alternative Group D considers a single lined modular combined-use facility for onsite disposal of all LLW, MLLW, ILAW, and WTP melters. This alternative group contains three subalternatives that correspond to different locations for the combined-use disposal facility. The subalternatives are denoted by subscripts. This group also includes use of existing LLW and MLLW disposal capacity before construction of new disposal facilities and appropriate closure as in Alternative Group A. The three subalternative locations for the single combined-use disposal facility are:

- Alternative Group D<sub>1</sub> – 200 East Area near the PUREX plant
- Alternative Group D<sub>2</sub> – 200 East Area LLBGs
- Alternative Group D<sub>3</sub> – at ERDF.

During final design a combined-use disposal facility could be configured in numerous ways. Different waste types could be disposed of in separate cells within a combined-use disposal facility, or different waste types could be disposed of in the same cell (commingled). Little interaction between the different waste types is anticipated because MLLW, ILAW, and the melters would meet applicable regulatory requirements for disposal. In addition, all waste types would need to meet the waste acceptance criteria for that disposal facility. The separate cells could be permitted under RCRA where appropriate, or the entire facility could be operated under a single regulatory program.

### **3.1.6 Alternative Group E**

Alternatives for storage, treatment, and processing of LLW, MLLW, and TRU waste are the same as those considered in Alternative Group A. This group also includes use of existing LLW and MLLW disposal capacity before construction of new disposal facilities and appropriate closure caps as in Alternative Group A. Alternative Group E considers two onsite lined combined-use facilities, one facility for combined disposal of LLW and MLLW, and a separate facility for combined disposal of ILAW and WTP melters. Alternative Group E contains three subalternatives that correspond to different combinations of locations for the two disposal facilities. The subalternatives are denoted by subscripts. This group also includes use of existing LLW and MLLW disposal capacity before construction of new disposal facilities and appropriate closure as in Alternative Group A. The subalternative locations for the two dual-use disposal facilities are:

- Alternative Group E<sub>1</sub> – combined disposal of LLW and MLLW in a modular lined facility in the 200 East Area LLBGs; combined disposal of WTP melters and ILAW in a modular lined facility at ERDF;

- Alternative Group E<sub>2</sub> – combined disposal of LLW and MLLW in a modular lined facility near PUREX; combined disposal of WTP melters and ILAW in a modular lined facility at ERDF; and
- Alternative Group E<sub>3</sub> – combined disposal of LLW and MLLW in a modular lined facility at ERDF; combined disposal of WTP melters and ILAW in a modular lined facility near PUREX.

During final design a combined-use disposal facility could be configured in numerous ways. Different waste types could be disposed of in separate cells within a combined-use disposal facility, or different waste types could be disposed of in the same cell (commingled). Little interaction between the different waste types is anticipated because MLLW, ILAW, and the melters would meet applicable regulatory requirements for disposal. In addition, all waste types would need to meet the waste acceptance criteria for that disposal facility. The separate cells could be permitted under RCRA where appropriate, or the entire facility could be operated under a single regulatory program.

### **3.1.7 Summary Tables of Alternative Groups**

To facilitate comparison and references for each of the alternative groups, Tables 3.1 and 3.2 summarize the various actions proposed as part of each group. Table 3.1 provides the treatment alternatives and Table 3.2 provides the disposal alternatives. Table 3.1 identifies the various treatment alternatives on a waste stream level and shows which individual alternatives (indicated by bullet) are included in each alternative group. The ILAW and melter waste types are not included in Table 3.1 since the treatment of ILAW and melters is part of the WTP scope. In Table 3.2 the individual disposal facility alternatives are shown for each alternative group.

## **3.2 Alternatives Considered but Not Evaluated in Detail**

This section describes alternatives that were considered as possible methods for the management of one or more of the waste types, but were not evaluated in detail, because DOE has determined that they are not currently reasonable alternatives. The alternatives are organized by the key activity of storage, treatment, and disposal. This section also provides a qualitative discussion of the Stop Work scenario.

### **3.2.1 Storage Options**

#### **3.2.1.1 Storage of Waste at the Generators' Sites**

Storage of waste at either the Hanford or offsite generators' sites could potentially reduce the storage requirements at CWC. However, the action alternatives do not require additional storage beyond the current CWC capacity. Storage at multiple sites would not allow DOE to take advantage of the economies of scale possible by consolidation of the wastes at CWC and would make security more difficult. Continued storage at generators' sites could be inconsistent with LDR requirements and site treatment plans. Most onsite and offsite generators do not have permitted onsite storage available and would need to increase storage capacity, which might adversely impact cleanup and closure activities.

**Table 3.1. Treatment Alternatives Summary**

Treatment Alternatives	Alternative Groups for Analysis					
	A	B	C	D	E	No Action
<b>LLW – Cat 1</b>						
None required; optional by generator	--	--	--	--	--	--
<b>LLW – Cat 3, GTC3</b>						
HICs or Trench Grouted	s	s	s	s	s	s
<b>LLW – Non-Conforming</b>						
Offsite Facility, establish new contract(s)	•		•	•	•	
New Waste Processing Facility in 200 W Area		•				
None (storage of untreated LLW)						•
<b>MLLW – RH &amp; Non-Standard Containers</b>						
Modified T Plant	•		•	•	•	
New Waste Processing Facility in 200 W Area		•				
None (storage of untreated MLLW)						•
<b>MLLW – CH Standard, Organic Solids &amp; Debris</b>						
Offsite Facility, complete existing commercial contract	s	s	s	s	s	s
Offsite Facility, establish new contract(s)	•		•	•	•	
New Waste Processing Facility in 200 W Area		•				
None (storage of untreated MLLW)						•
<b>MLLW – CH Standard, Elemental Lead, Elemental Mercury</b>						
Offsite Facility	•		•	•	•	
New Waste Processing Facility in 200 W Area		•				
None (storage of untreated MLLW)						•
<b>MLLW – Disposal Trench Leachate</b>						
Effluent Treatment Facility (ETF)	s	s	s	s	s	s
Pulse dryers after ETF closure	s	s	s	s	s	s
<b>TRUW – CH Standard (retrievably stored in LLBGs &amp; CWC, newly generated)</b>						
WRAP	•	•	•	•	•	•
Mobile Units (APLs) in 200 W Area	•	•	•	•	•	•
<b>TRUW – CH Non-Standard (LLBGs, CWC, newly generated), RH (LLBGs, caissons, CWC, newly generated), K Basin sludge, PCB Commingled</b>						
Modified T Plant	•		•	•	•	
New Waste Processing Facility in 200 W Area		•				
Mobile Units (APLs) in 200 W Area	•	•	•	•	•	•
None (storage of unprocessed TRU Waste)						•
-- = Activity not included in analysis.						
s = Activity included in analysis; same for all alternatives.						
• = Alternative actions evaluated in analysis group.						



**Table 3.2. Disposal Alternatives Summary**

Disposal Alternatives for New Construction <sup>(a)</sup>	Alternative Groups for Analysis									
	A	B	C	D			E			No Action
				1	2	3	1	2	3	
<b>LLW – Cat 1, Cat 3, GTC3, Non-Conforming</b>										
200 W LLBG – Existing design unlined trenches		•								
200 W LLBG – Deeper, wider unlined trenches	•									
200 W LLBG – Single unlined trench			•							
Near PUREX – Modular combined-use lined facility				•				•		
200 E LLBG – Modular combined-use lined facility					•		•			
ERDF – Modular combined-use lined facility						•			•	
200 W LLBG – Existing design unlined trenches, backfill only, no barrier (Cat 1, Cat 3, GTC3 LLW)										•
None (storage of non-conforming LLW)										•
<b>Previously Buried Waste</b>										
Install Modified RCRA Subtitle C Barrier	•	•	•	•	•	•	•	•	•	
Backfill only, no RCRA barrier										•
<b>MLLW – treated, ready for disposal, RH &amp; CH MLLW, Elemental Lead &amp; Elemental Mercury, solids from MLLW leachate treatment</b>										
200 E LLBG – Existing design lined trenches		•								
200 E LLBG – Deeper, wider lined trenches	•									
200 E LLBG – Single expandable lined trench			•							
Near PUREX – Modular combined-use lined facility				•				•		
200 E LLBG – Modular combined-use lined facility					•		•			
ERDF – Modular combined-use lined facility						•			•	
None (storage of untreated MLLW and treated MLLW in excess of existing disposal capacity)										•
<b>TRUW – CH Standard</b>										
Ship to Waste Isolation Pilot Plant	s	s	s	s	s	s	s	s	s	s
<b>TRUW – CH Non-Standard, RH, K Basin sludge, PCB</b>										
Ship to Waste Isolation Pilot Plant	•	•	•	•	•	•	•	•	•	
None (storage of unprocessed TRUW)										•
<p>(a) In all cases, existing trench space for LLW and MLLW in the 200 W Area, LLBGs would be filled before constructing new disposal capacity. All disposal facilities would be covered with a Modified RCRA Subtitle C Barrier as filled or at closure, except as noted.</p> <p>S = Activity included in analysis; same in all alternative groups.</p> <p>• = Alternative actions evaluated in analysis group.</p>										

**Table 3.2. (contd)**

Disposal Alternatives for New Construction <sup>(a)</sup>	Alternative Groups for Analysis									No Action
	A	B	C	D			E			
				1	2	3	1	2	3	
<b>WTP Melters</b>										
Near PUREX – Single lined trench	•		•							
200 E LLBG – Single lined trench		•								
Near PUREX – Modular combined-use lined facility				•					•	
200 E LLBG – Modular combined-use lined facility					•					
ERDF – Modular combined-use lined facility						•	•	•		
None (storage)										•
<b>ILAW</b>										
Near PUREX – Multiple lined trenches	•									
200 W Area – Multiple lined trenches		•								
Near PUREX – Single lined trench			•							
Near PUREX – Modular combined-use lined facility				•					•	
200 E LLBG – Modular combined-use lined facility					•					
ERDF – Modular combined-use lined facility						•	•	•		
Near PUREX – Lined vault disposal facility										•
<p>(a) In all cases, existing trench space for LLW and MLLW in the 200 W Area, LLBGs would be filled before constructing new disposal capacity. All disposal facilities would be covered with a Modified RCRA Subtitle C Barrier as filled or at closure, except as noted.</p> <p>• = Alternative actions evaluated in analysis group.</p>										

**3.2.1.2 Shipment of Hanford GTC3 Wastes to Other Sites for Longer-Term Storage**

No GTC3 LLW is forecast to be generated at Hanford, but 1 m<sup>3</sup> is assumed for analysis to address future contingencies. The amount of storage required for this waste is so small in comparison with other wastes, that storage of this waste at Hanford is not expected to impact the required capacity at CWC in any of the alternatives. Shipment of GTC3 wastes from Hanford to other DOE sites would not be consistent with the WM PEIS ROD (65 FR 10061) for LLW and MLLW. The effort required to send waste to another site would be greater than the effort to store onsite. Thus, the most reasonable storage alternative for GTC3 LLW is storage in CWC.

**3.2.2 Treatment Options**

**3.2.2.1 Use of Offsite DOE Facilities for Treatment of All Hanford Waste**

The consolidation of waste management functions at designated DOE sites was a major focus of the WM PEIS (DOE 1997a). Attempts were made to identify treatment capacity at other DOE sites for Hanford wastes, but treatment capacity is limited at other DOE sites. Therefore, this is not a reasonable

alternative for all Hanford waste. If DOE were able to ship wastes to other DOE sites for treatment, potential impacts would be similar to those for commercial treatment. Hanford may ship small-volume waste streams to other DOE sites in the future if specialized facilities become available. However, impacts of those shipments would be similar to those included for offsite treatment of MLLW.

### **3.2.2.2 Use of the Effluent Treatment Facility for Non-Conforming LLW**

Much of the non-conforming LLW stream is organic-based liquid. The treatment of these liquids in the ETF was considered. However, organic-based liquids wastes are not compatible with the aqueous-based ETF treatment system.

## **3.2.3 Disposal Options**

### **3.2.3.1 Use of Canyon Facilities for Disposal of Specific Wastes**

An ongoing CERCLA study is considering the use of the major canyon facilities for disposal of some waste types that are included in the HSW EIS (Hanford Advisory Board 1997; Richland Environmental Restoration Project 2001). As currently envisioned, higher hazard waste such as Cat 3 LLW would be placed inside the canyons and lower activity wastes (Cat 1 LLW, for example) would be placed above and outside the canyon. Waste in the cells might be grouted in place, which would provide additional protection from intrusion as well as mitigating contaminant transport. The entire facility would then be capped with an engineered barrier. Performance monitoring of the barrier would be conducted and adjustments made as necessary. The canyons, with their thick cement walls, would provide containment of the wastes inside and retard their dispersal over the long term. The wastes outside the canyons should be as well contained as wastes placed in the LLBGs. This concept is not sufficiently well developed for detailed analysis at this time. It is being studied as part of the CERCLA process, and if pursued, would be subject to future environmental review before implementation.

### **3.2.3.2 Leave Retrievably Stored Transuranic Waste in the Low Level Burial Grounds**

In this alternative, retrievably stored TRU waste in trenches and caissons would remain buried and would not be retrieved. Further actions could be taken to minimize environmental impacts, including the placement of a barrier over the waste to reduce the potential for further waste migration. This alternative would be attractive from an operational standpoint because it would reduce worker exposure to radioactive materials from retrieval, treatment, and transportation activities, particularly the high radiation doses from RH TRU wastes in the caissons. Modeling of this alternative indicates that it would not result in substantial radionuclide discharges to the accessible environment; however, it would not be consistent with previous NEPA decisions to retrieve the waste or with the national policy to ship TRU waste to WIPP.

### **3.2.3.3 Use of US Ecology Disposal Facility**

The US Ecology commercial LLW disposal site is located on land leased to the State of Washington near the 200 Areas within the Hanford Site boundary and could receive some of the LLW expected to be buried in Hanford Solid Waste disposal facilities. A draft State of Washington Environmental Policy Act (SEPA) EIS for the US Ecology facility has been issued (WDOH and Ecology 2000). However, this alternative was not considered reasonable as a replacement for DOE disposal capabilities because some wastes managed by DOE could not be accepted by commercial facilities, and the Hanford infrastructure would still be necessary to manage those wastes. Disposal of DOE waste in commercial facilities would also reduce the limited capacity available for commercial waste disposal. This alternative would offer no clear environmental benefit. LLW would be disposed of on the Central Plateau in unlined trenches, and costs for disposal would be higher.

### **3.2.3.4 Disposal of All Hanford LLW or MLLW at Other Sites**

DOE previously decided that Hanford LLW and MLLW would be disposed of at Hanford (65 FR 10061). Adequate commercial disposal capacity is not available. In view of the large volumes of waste at Hanford, the cost and number of shipments involved with shipping these wastes offsite, and the limited availability of offsite disposal capacity for certain waste types, DOE does not regard shipping the bulk of Hanford waste to other sites for disposal as a reasonable alternative.

## **3.2.4 Stop Work Scenario**

In response to stakeholder comments DOE has included a Hanford Only scenario for waste volumes and included a qualitative discussion of a Stop Work scenario for purposes of comparison with the No Action Alternative as described in the previous section. In the Stop Work scenario, all waste management operations including storage, treatment, and disposal would be terminated. No more waste would be processed or treated, and no waste would be disposed of. This scenario would not be in conformance with DOE agreements in the TPA, applicable regulations, or previous NEPA decisions. DOE does not consider this to be a reasonable scenario. Specific actions to be taken for each waste type are noted below and then onsite and offsite impacts are briefly identified. A variation of the Stop Work scenario in which Hanford would cease disposing of LLW and MLLW onsite, but would otherwise maintain normal waste management operations, is discussed and evaluated further in Appendix M.

Under the Stop Work scenario receipt of LLW would be terminated. Hanford wastes would be stored by the generator, and no offsite wastes would be received. When generators run out of storage space their activities would have to stop also, or other disposal capacity would need to be identified. No further action would be taken to dispose of waste or to cap the burial grounds. Thus, wastes in the uncapped burial grounds would be exposed to increased water percolation and release to the groundwater.

Under the Stop Work scenario no further MLLW would be received from onsite or offsite generators. Waste would be left in storage, and no treatment of existing or future-generated wastes would occur. No disposal of additional wastes would take place and there would be no closure of the existing MLLW disposal trenches.

Under the Stop Work scenario no further TRU waste would be received from onsite or offsite activities. Generators, such as the Plutonium Finishing Plant, would be required to store waste and ultimately cease operations. There would be no retrieval of suspect TRU waste from the burial grounds. There would be no processing or certification of wastes in WRAP or other facilities, and the wastes would be stored. Waste shipments to the WIPP would cease.

In this scenario for the WTP, DOE would not have the ability to dispose of the ILAW at the Hanford Site. Because of limited storage space for ILAW, tank waste retrieval and operations at the WTP would be jeopardized.

Waste generators (onsite or offsite) would not be able to dispose of waste at Hanford and would have to make other arrangements. The majority of the wastes would require storage at the generator sites. However, storage at multiple sites would not allow DOE to take advantage of the economies of scale possible by consolidating waste management activities. Lastly, most generators are not permitted to store MLLW longer than 90 days. Most onsite and offsite generators do not have onsite storage available, and the need to increase storage capacity could impact cleanup and closure activities and increase environmental impacts at Hanford and other DOE sites.

### 3.3 Volumes of Waste Considered in Each Alternative

The environmental impacts of the alternatives considered in this EIS will depend in part on the volumes of each waste type managed at the Hanford Site. In order to assess the impacts of different amounts of waste, alternative waste volume scenarios have been analyzed: Hanford Only, Lower Bound, and Upper Bound.

- The **Hanford Only** waste volume consists of 1) the forecast volumes of LLW, MLLW, and TRU waste from Hanford Site generators, 2) the forecast ILAW and melter volumes from treatment of Hanford tank waste, and 3) existing onsite inventories of waste that are already in storage. The analysis also includes waste that has previously been disposed of in the LLBGs.
- The **Lower Bound** waste volume consists of 1) the Hanford Only volume, and 2) additional volumes of LLW and MLLW that are currently forecast for shipment to Hanford from offsite facilities. The Lower Bound volume for TRU waste is not substantially greater than the Hanford Only volume, and is not analyzed separately in all cases.
- The **Upper Bound** waste volume consists of 1) the Lower Bound volume, and 2) estimates of additional LLW, MLLW, and TRU waste volumes that may be received from offsite generators as a result of the WM PEIS decisions.

A comparison of the waste volumes used for the HSW EIS analyses is shown in Figure 3.3.

The summary volumes used for each waste type are presented in the following sections. Annual volumes corresponding to the total volumes shown in the tables in this section are listed in Section B.4 of Appendix B (Volume II). These volumes represent the “as-received” volume of waste. As the wastes are

treated and prepared for disposal their volumes may change. The changes in volume can be noted in the processing assumptions in Section B.4 of Appendix B (Volume II) and in the flowsheets in Section B.6. A more detailed description of the development of the waste volumes for each type of waste is included in Appendix C (Volume II). The number of significant figures shown in the volume tables can exceed the accuracy of the forecasts but are maintained in the document for consistency of calculations. The radiological and chemical profiles for these waste volumes are in Section B.5 of Appendix B and Appendix F (Volume II), respectively, as well as in the Technical Information Document (FH 2004).

### 3.3.1 LLW Volumes

The alternatives for management of LLW have been analyzed using all three sets of volumes. Table 3.3 shows the volumes of each LLW stream included in each data set. The total LLW in the Hanford Only waste volume is 411,000 m<sup>3</sup>. The Lower Bound and Upper Bound waste volumes represent increases of approximately 21,000 m<sup>3</sup> and 220,000 m<sup>3</sup>, respectively, compared with the Hanford Only waste volume. The only additional LLW expected to be managed in the Lower Bound and Upper Bound cases are LLW Cat 1 and Cat 3.

**Table 3.3.** Estimated Volumes of LLW Waste Streams

Waste Streams	Hanford Only (cubic meters) <sup>(a)</sup>	Lower Bound (cubic meters) <sup>(a)</sup>	Upper Bound (cubic meters) <sup>(a)</sup>
Cat 1	88,792	107,883	287,130
Cat 3	39,607	41,334	60,933
GTC3	<1	<1	<1
Non-conforming	299	299	299
Previously disposed waste in LLBGs	283,067	283,067	283,067
Total <sup>(b)</sup>	411,765	432,584	631,429
(a) To convert to cubic feet, multiply by 35.3.			
(b) Totals may not equal the sum of the waste stream volumes due to rounding.			

### 3.3.2 MLLW Volumes

As with LLW, the alternatives for management of MLLW have been analyzed using all three sets of waste volumes. The MLLW stream volumes included in each data set are shown in Table 3.4. Slightly over 58,400 m<sup>3</sup> are expected to be managed in the Hanford Only case. Only a small amount of additional waste, approximately 100 m<sup>3</sup>, is expected to be managed in the Lower Bound case. The additional volume of waste that would be managed under the Upper Bound case is approximately 140,000 m<sup>3</sup>. It is assumed in this EIS that the additional MLLW received in the Upper Bound case would be treated prior to receipt at Hanford and that the waste would be disposed of directly. Therefore, this additional MLLW is included in the Treated and Ready for Disposal waste stream.

**Table 3.4.** Estimated Volumes of MLLW Waste Streams

<b>Waste Streams<sup>(a)</sup></b>	<b>Hanford Only (cubic meters)<sup>(b)</sup></b>	<b>Lower Bound (cubic meters)<sup>(b)</sup></b>	<b>Upper Bound (cubic meters)<sup>(b)</sup></b>
Treated and Ready for Disposal	28,054	28,082	168,419
RH and Non-Standard Packages	2904	2904	2904
CH Inorganic Solids and Debris	20,108	20,111	20,111
CH Organic Solids and Debris	6727	6790	6790
Elemental Lead	600	608	608
Elemental Mercury	21	21	21
Total <sup>(c)</sup>	58,414	58,515	198,852
(a) Leachate from MLLW trenches has not been included in this table because the volumes are dependent upon the selected alternative. The total volume of leachate from the MLLW trenches by alternative can be found in the flowcharts in Appendix B.			
(b) To convert to cubic feet, multiply by 35.3.			
(c) Totals may not equal the sum of the waste stream volumes due to rounding.			

### 3.3.3 TRU Waste Volumes

The three sets of volumes developed for TRU waste are presented in Table 3.5. The Hanford Only waste volume is approximately 45,700 m<sup>3</sup>. The Lower Bound waste volume is only slightly larger and includes approximately 57 m<sup>3</sup> from offsite generators. In the Upper Bound case, an additional 1,500 m<sup>3</sup> of TRU waste from offsite generators could be received for temporary storage and eventual shipment to WIPP. Because the differences between the three sets of volumes are small, environmental impacts have been evaluated for the Hanford Only and Upper Bound cases only.

**Table 3.5.** Estimated Volumes of TRU Waste Streams

<b>Waste Streams</b>	<b>Hanford Only (cubic meters)<sup>(a)</sup></b>	<b>Lower Bound (cubic meters)<sup>(a)</sup></b>	<b>Upper Bound (cubic meters)<sup>(a)</sup></b>
Waste from trenches	14,552	14,552	14,552
Waste from caissons	23	23	23
Commingled PCB waste	80	95	95
Newly generated and existing CH standard containers	27,719	27,727	28,897
Newly generated and existing CH non-standard containers	1077	1077	1357
Newly generated and existing RH	2157	2191	2241
K Basin sludge	139	139	139
Total TRU waste <sup>(b)</sup>	45,748	45,805	47,305
(a) Convert to cubic feet, multiply by 35.3.			
(b) Totals may not equal the sum of the waste stream volumes due to rounding.			

### 3.3.4 Waste Treatment Plant Waste Volumes

Waste volumes expected from the Waste Treatment Plant are shown in Table 3.6. Because these wastes would be generated at Hanford, the Lower Bound and Upper Bound cases are not applicable. The volume of ILAW generated by the WTP, however, may vary depending on the waste form produced. For the No Action Alternative, ILAW would be produced in a cullet form and packaged in containers for retrievable disposal in vaults as outlined in the TWRS EIS for the preferred alternative (Phased Implementation). The EIS analysis assumed 140,000 containers would be required, or an equivalent volume of approximately 350,000 m<sup>3</sup>. For the action alternatives, ILAW was assumed to be in a monolithic form, packaged in 2.6-m<sup>3</sup> containers for disposal in trenches. Approximately 81,000 containers would be required, or an equivalent volume of approximately 211,000 m<sup>3</sup> (Burbank 2002).

**Table 3.6.** Estimated Volumes of WTP Waste Streams Through 2046

Waste Streams	No Action (cubic meters) <sup>(a)</sup>	Action Alternatives (cubic meters) <sup>(a)</sup>
ILAW	350,000	211,000
WTP Melters	6,825	6,825
Total WTP waste	356,825	217,825
(a) To convert to cubic feet, multiply by 35.3.		

### 3.4 Comparison of Environmental Impacts Among the Alternatives

For purposes of comparison of the impacts among the alternatives in this section, impacts associated with alternative treatment, storage, and disposal actions for each waste type have been combined to provide a consolidated analysis of HSW management operations. These consolidated analyses are referred to as alternative groups, which were described in Section 3.1. The No Action Alternative analysis consists of activities resulting from taking no action for each waste type. This approach facilitates comparative presentation of impacts for all solid waste program operations evaluated in this EIS and is necessary where analyses are performed for facilities that are used to manage more than one type of waste. In the alternative group analyses, each of the waste types and activities necessary to manage those wastes are considered. In addition, within the analyses for each alternative group, three alternative waste volume scenarios were considered as described in Section 3.2, namely the Hanford Only, Lower Bound, and Upper Bound waste volumes.

Summary comparisons of impacts among the alternative groups during the operational period and during the long term (10,000 years) after disposal facility closure are presented in Tables 3.7 and 3.8, respectively. The environmental consequences presented in this section represent the impacts from implementing the alternatives for solid waste management described in Section 3.1.

Potential environmental impacts resulting from implementing any of the alternatives are compared in somewhat more detail in the sections that follow. Further details and the supporting analyses for the material presented in this section are provided in Section 5 and its appendixes.



**Table 3.7. Summary Comparison of Potential Impacts Among the Alternatives During the Operational Period (Present to 2046)**

Alternative Groups A-E – Hanford Only to Upper Bound Waste Volume <sup>(a)</sup>															
No Action Alternative Hanford Only to Lower Bound Waste Volume <sup>(b)</sup>															
Alternative	Facility Operations – Direct Radiation and Emissions to Atmosphere					Transportation						Shrub-Steppe Habitat Disturbed, ha	Geologic Resources Committed (sand, gravel, silt/loam, and basalt), millions of m <sup>3(g)</sup>	Diesel Fuel Committed Thousands of m <sup>3</sup>	Cost in Billions of 2002 Dollars
	Normal Operations				Fatalities from Operational Accident Having Largest Consequences: Beyond-Design-Basis Earthquake at CWC <sup>(c)</sup>	Incident-Free	# Accidents/# Fatalities from Accidents								
	Chances of Latent Cancer Fatality: Lifetime Exposure of Maximally Exposed Individual		Latent Cancer Fatalities (LCFs) Among Population within 80 km Lifetime Exposure	Latent Cancer Fatalities (LCFs) from Collective Radiation Exposure of Workers			Onsite, from Offsite, for Treatment, & TRU Waste to WIPP: Includes Transport-Crew, Public, and Non-Involved Workers, Fatalities <sup>(f)</sup>	Onsite, from Offsite, for Offsite Treatment, and TRU Waste to WIPP <sup>(d)</sup>	LLW, MLLW & TRU Waste Within Ore. State Only <sup>(d)</sup>	LLW, MLLW & TRU Waste Within Wash. State Only <sup>(d)</sup>	TRU Waste to WIPP				
	Public	Non-Involved Workers			Public	Non-Involved Workers <sup>(e)</sup>									
<b>Group A</b>	<1/million	<1/million	0 (<0.001)	0 (<0.5)	30	1	6–9	23/1-75/3	1/0–5/0	0/0–2/0	17/1	32	4.0-4.2	133–134	3.7–4.0
<b>Group B</b>	<1/million	<1/million	0 (<0.001)	0 (<0.5)	30	1	6–10	22/1-74/2	1/0–5/0	0/0–2/0	17/1	0	4.4-4.9	137–141	3.8–4.2
<b>Group C</b>	<1/million	<1/million	0 (<0.001)	0 (<0.5)	30	1	6–9	23/1-75/3	1/0–5/0	0/0–2/0	17/1	14	3.7-4.0	66–67	3.5–3.9
<b>Group D<sub>1</sub></b>	<1/million	<1/million	0 (<0.001)	0 (<0.5)	30	1	6–9	23/1-75/3	1/0–5/0	0/0–2/0	17/1	19–25	3.7-3.9	66–67	3.2–3.5
<b>Group D<sub>2</sub></b>	<1/million	<1/million	0 (<0.001)	0 (<0.5)	30	1	6–9	23/1-75/3	1/0-5/0	0/0–2/0	17/1	0	3.9-4.0	66–67	3.2–3.5
<b>Group D<sub>3</sub></b>	<1/million	<1/million	0 (<0.001)	0 (<0.5)	30	1	6–9	23/1-75/3	1/0-5/0	0/0–2/0	17/1	0	3.7-3.9	66–67	3.2–3.5
<b>Group E<sub>1</sub></b>	<1/million	<1/million	0 (<0.001)	0 (<0.5)	30	1	6–9	23/1-75/3	1/0-5/0	0/0–2/0	17/1	0	3.7-3.8	66–67	3.4–3.8
<b>Group E<sub>2</sub></b>	<1/million	<1/million	0 (<0.001)	0 (<0.5)	30	1	6–9	23/1-75/3	1/0-5/0	0/0–2/0	17/1	5–11	3.7-3.8	66–67	3.4–3.8
<b>Group E<sub>3</sub></b>	<1/million	<1/million	0 (<0.001)	0 (<0.5)	30	1	6–9	23/1-75/3	1/0-5/0	0/0–2/0	17/1	14	3.7-3.8	66–67	3.4–3.8
<b>No Action</b>	<1/million	<1/million	0 (<0.001)	1 (0.5)	30	1	2–2	10/0-13/0	1/0-1/0	0/0–0/0	8/0	10	2.7	189	3.5–3.5

See footnotes for this table on the next page.

### Footnotes for Table 3.7

- (a) For the action alternative groups, values represent the range for the Hanford Only to Upper Bound waste volume. Where a single value is given, the value applies to both Hanford Only and Upper Bound waste volumes. Values for health effects are rounded to the nearest whole number; values less than 0.5 are presented as zero.
- (b) For the No Action Alternative, values represent the range for the Hanford Only to Lower Bound waste volume. Where a single value is given, the value applies to both Hanford Only and Lower Bound waste volumes. Values for health effects are rounded to the nearest whole number; values less than 0.5 are presented as zero.
- (c) Unlike the action alternative groups where the risk of this accident would be over about 43 years, risk for the No Action Alternative would continue as long as waste is stored in CWC.
- (d) Values are for Lower to Upper Bound waste volumes. The first value applies to the accidents and fatalities for the Lower Bound waste volume; the second value applies to the Upper Bound waste volume.
- (e) The value shown is the probability of an LCF based on the calculated dose from the accident – the number of such non-involved workers is unknown, but likely would range from none to no more than 5. For the “involved” worker(s) that might be in a CWC building during such an event the consequences could range from none to several fatalities from collapse of the building.
- (f) Consists of inferred fatalities from radiation exposure and vehicular emissions. In the final HSW EIS all offsite transport is addressed, including transport of TRU waste to WIPP and the entire transportation route for offsite waste sent to Hanford.
- (g) As a result of refined calculations of resource needs based on the Technical Information Document (FH 2004), the need for gravel and sand, silt/loam, and basalt for action alternative groups increased by factors of approximately 1.8, 2.6, and 1.2, respectively, over those reported in the DEIS.

**Table 3.8.** Summary Comparison of Hypothetical Long-Term (up to 10,000 years) Impacts Among the Alternatives

Alternative Groups A-E–Hanford Only to Upper Bound Waste Volume <sup>(a)</sup>											
No Action Alternative–Hanford Only to Lower Bound Waste Volume <sup>(b)</sup>											
Alternative	Additional Land Permanently Committed to Disposal, ha	Exposure to Radionuclides Via Groundwater Pathway								Waste Site Intruder Maximum Risk of Fatality at 100 Years After Closure <sup>(e)</sup>	
		Maximum Annual Drinking Water Dose, millirem <sup>(e, g)</sup>		Maximum Chances in a Million of Fatality (LCF) to Lifetime Onsite Resident Gardener <sup>(e, g)</sup>		Maximum Chances in a Million of Fatality (LCF) for Lifetime Onsite Resident Gardener with Sauna/Sweat Lodge <sup>(e, g)</sup>		Fatalities (LCFs) in Populations over 10,000 years <sup>(d)</sup>			
		200 Areas <sup>(f)</sup>	Near River	200 Areas <sup>(f)</sup>	Near River	200 Areas <sup>(f)</sup>	Near River	Tri-Cities	Portland	Drilling	Excavation <sup>(h)</sup>
<b>Group A</b>	38–47	0.4	0.05	60	6	3000	200	0	0	4 in 100	Not applicable
<b>Group B</b>	56–80	0.4	0.04	50–60	6–7	7000–8000	200–300	0	0	4 in 100	Not applicable
<b>Group C</b>	20–29	0.4	0.04–0.05	60	6–7	3000	200	0	0	4 in 100	Not applicable
<b>Group D<sub>1</sub></b>	19–25	0.2	0.05	20–30	7–8	2000	200	0	0	4 in 100	Not applicable
<b>Group D<sub>2</sub></b>	19–25	0.2	0.06	30	8–9	4000	200	0	0	4 in 100	Not applicable
<b>Group D<sub>3</sub></b>	19–25	0.3–0.4	0.05	50	6–7	3000–4000	200	0	0	4 in 100	Not applicable
<b>Group E<sub>1</sub></b>	19–25	0.2	0.06	30	8–9	3000	200	0	0	4 in 100	Not applicable
<b>Group E<sub>2</sub></b>	19–25	0.2	0.04	30	5	3000	200	0	0	4 in 100	Not applicable
<b>Group E<sub>3</sub></b>	19–25	0.3–0.4	0.04	50	6	2000	200	0	0	4 in 100	Not applicable
<b>No Action</b>	86–95 <sup>(c)</sup>	0.4–0.5	0.04	50–140	5	10,000–20,000	600	0	0	4 in 100	Likely fatality

(a) Where a single value is given it is essentially the same for the Hanford Only and Upper Bound waste volumes.  
 (b) Where a single value is given it is essentially the same for the Hanford Only and Lower Bound waste volumes.  
 (c) Includes additional land for long-term storage of waste that cannot be treated or processed for disposal.  
 (d) Zero inferred latent cancer fatalities. Assumed populations; Tri-Cities – 113,000; Portland – 510,000.  
 (e) Risk value given assumes that the event takes place; i.e., active institutional controls are not maintained after 100 years.  
 (f) Results presented are for a location within the 200 Areas having the highest radionuclide concentrations along a line of analysis 1-km downgradient from HSW disposal facilities. Sensitivity cases were also evaluated to determine the relationship of concentrations at the 1-km location to those at the waste management area or facility boundaries. The results of those analyses are presented in Volume I, Section 5.3.  
 (g) Differences in impacts compared with those presented in the revised draft EIS reflect additional mitigation to reduce the release and transport of contaminants resulting from assumed disposal of some forecast MLLW using higher integrity containment, such as HICs, macroencapsulation, and in-trench grouting.  
 (h) Excavation is not considered to be a reasonably foreseeable scenario for the action alternative groups because the depth of the barrier placed over disposal facilities at closure is greater than the depth of a typical basement excavation for a residence. The dose estimated for this scenario in the No Action Alternative likely would lead to fatality.

### 3.4.1 Land Use

Land permanently committed to HSW disposal includes about 130 ha (320 ac) occupied by waste previously disposed of in LLBGs. Disposal of the Hanford Only waste volume would increase land permanently committed for disposal from a low of 19 ha (47 ac) for Alternative Groups D and E, to a high of 56 ha (140 ac) for Alternative Group B (land-use values are rounded and may not add or convert exactly). Similarly, the increases for the Lower Bound waste volume would range from 20 ha (49 ac) to 59 ha (150 ac) for the same alternative groups. The increases for the Upper Bound waste volume would range from 25 ha (62 ac) to 80 ha (200 ac) for the same alternative groups. Therefore, disposal of forecast Hanford waste represents a 15- to 43-percent increase over land currently occupied in the LLBGs. Disposal of waste from other sites at the Upper Bound waste volume would increase the land area required by 4 to 13 percent over that needed for existing and forecast Hanford waste. In the No Action Alternative, the increase in land permanently committed to disposal would be about 28 ha (69 ac), which, however, does not take into account an increase in land usage of 66 ha (160 ac) for facilities committed to storage of LLW, MLLW, and TRU waste that could not be disposed of using existing capabilities. The areas of land to be committed are shown for comparison among the alternative groups in Table 3.9.<sup>(a)</sup> The analyses for land use can be found in Section 5.1.

**Table 3.9.** Comparison of Land Area Permanently Committed in the Various Alternatives as of 2046, ha<sup>(a)</sup>

Alternative	Hanford Only Waste Volume			Lower Bound Waste Volume			Upper Bound Waste Volume		
	LLW & MLLW Increase	ILAW Increase	Total Land Committed <sup>(b)</sup>	LLW & MLLW Increase	ILAW Increase	Total Land Committed <sup>(b)</sup>	LLW & MLLW Increase	ILAW Increase	Total Land Committed <sup>(b)</sup>
Alternative Group A	12	26	<b>169</b>	13	26	<b>170</b>	21	26	<b>178</b>
Alternative Group B	30	26	<b>187</b>	33	26	<b>189</b>	54	26	<b>210</b>
Alternative Group C	12	8	<b>151</b>	13	8	<b>152</b>	21	8	<b>160</b>
Alternative Groups D & E	11	8	<b>150</b>	12	8	<b>150</b>	17	8	<b>155</b>
No Action Alternative	17	10	<b>273<sup>(c)</sup></b>	19	10	<b>275<sup>(c)</sup></b>	Not applicable		

(a) One hectare (ha) = about 2.5 acre (ac). Values may not add exactly due to rounding.  
 (b) Includes 130 ha already committed for HSW previously disposed of in the LLBGs.  
 (c) Includes 116 ha for storage of waste in CWC buildings.

(a) Land committed represents land within which waste would be emplaced. It is assumed that buffer zones would be maintained around these waste disposal sites consistent with the Hanford Comprehensive Land-Use Plan Environmental Impact Statement Record of Decision (64 FR 61615).

Land occupied by existing treatment and storage facilities amounts to 127 ha (314 ac), which would not require expansion under any of the action alternatives except Alternative Group B. Construction of a new waste processing facility would add 4 ha (10 ac) to the total for that alternative group. At most, total land use for solid waste operations, including treatment, storage, and disposal facilities, would be about 4 percent of the 200 Area Industrial-Exclusive zone.

### 3.4.2 Air Quality

Air quality impacts are based on estimated concentrations of criteria pollutants: particulate matter (PM<sub>10</sub>), sulfur dioxide (SO<sub>2</sub>), carbon monoxide (CO), and nitrogen dioxide (NO<sub>2</sub>) at points of public occupancy. Table 3.10 presents the largest potential impacts calculated for each alternative group in comparison to air quality standards. Air quality impacts for obtaining capping materials are presented separately following the table. Impacts from releases of radioactive material and chemicals to the atmosphere are addressed in Section 3.4.11 and 5.11, Human Health and Safety.

Maximum air quality impacts from operating the Area C borrow pit would amount to 14 percent of the 24-Hour Standard for PM<sub>10</sub>, 26 percent of the 1-Hour Standard for SO<sub>2</sub>, 36 percent for the 8-Hour Standard for CO, and 0.16 percent of the Annual Standard for NO<sub>2</sub>. These impacts would be common to all alternatives.

For the most part, the impacts on air quality are essentially the same for all alternatives. An exception is Alternative Group B where the impacts for some pollutants are below standard values, but noticeably higher than for the other alternatives due to the increased excavation required for construction of disposal trenches.

**Table 3.10.** Comparison Among the Alternative Groups of Estimated Criteria-Pollutant Impact Maximums for Solid Waste Operations in the 200 Areas, Percent of Air Quality Standards<sup>(a)</sup>

Alternative	Hanford Only and Lower Bound Waste Volumes				Upper Bound Waste Volume			
	24-Hour PM <sub>10</sub>	1-Hour SO <sub>2</sub>	8-Hour CO	Annual NO <sub>2</sub>	24-Hour PM <sub>10</sub>	1-Hour SO <sub>2</sub>	8-Hour CO	Annual NO <sub>2</sub>
Alternative Group A	46	8.1	4.7	0.72	49	9.8	5.9	0.80
Alternative Group B	47	13	8.0	1.0	60	18	11	1.1
Alternative Group C	40	7.9	4.6	0.77	41	8.0	4.7	0.77
Alternative Group D	41	8.4	5.0	0.79	41	8.4	5.0	0.85
Alternative Group E	40	9.3	5.3	0.89	41	9.5	5.3	0.89
No Action Alternative	38	8.6	4.6	0.85	Not applicable			

(a) (24-Hour PM<sub>10</sub> = 150 µg/m<sup>3</sup>, 1-Hour SO<sub>2</sub> = 1,000 µg/m<sup>3</sup>, 8-Hour CO = 10,000 µg/m<sup>3</sup>, Annual NO<sub>2</sub> = 100 µg/m<sup>3</sup>).

### 3.4.3 Water Quality

As a result of wastewater management activities during past Hanford Site operations, groundwater beneath the 200 Areas has been contaminated with radionuclides and non-radioactive chemicals. The contaminants emanating from the 200 Areas are moving toward the Columbia River. None of these contaminants is thought to have originated from existing LLBGs or other waste management facilities being considered in the HSW EIS. Uncertainties regarding levels of chemicals previously disposed of in LLBGs are discussed in Section 3.5.

One benchmark measure of water quality for purposes of comparison among the alternative groups is taken as the percentage of maximum contaminant levels (MCLs)<sup>(a)</sup> in groundwater. The percentage of MCLs is calculated for hypothetical wells intercepting maximum combined concentrations of radionuclides in predicted plumes along several lines of analysis (LOA) downgradient from the HSW disposal facilities. These lines of analysis were positioned at a distance to capture contributions from all HSW disposal facilities within the 200 West Area, the 200 East Area, and at the ERDF. The 200 East Area results include possible contributions from upgradient sources at the 200 West Area and ERDF. The specific lines of analysis considered in this assessment are as follows:

- a line of analysis 1 km downgradient from waste disposed of in the 200 West Area LLBGs or the ILAW waste disposal facility near CWC (referred to as the 200 West LOA in Section 5.3 and in Volume II, Appendix G).
- a line of analysis about 1 km downgradient to the northwest from the 200 East LLBGs (referred to as the 200 East NW LOA in Section 5.3 and in Volume II, Appendix G). This LOA was used to evaluate concentrations in groundwater migrating northwest of the 200 East Area.
- a line of analysis about 1 km downgradient to the southeast from a new disposal facility near the PUREX Plant (referred to as the 200 East SE LOA in Section 5.3 and in Volume II, Appendix G). This LOA was used to evaluate concentrations in groundwater migrating southwest of the 200 East Area.
- a line of analysis about 1 km downgradient from the ERDF location (referred to as the ERDF LOA in Section 5.3 and in Volume II, Appendix G).
- a line of analysis along the Columbia River (referred to as the Columbia River LOA in Section 5.3 and in Volume II, Appendix G).

The highest percentages of MCLs together with the time of occurrence are given in Table 3.11 for the period ending about 10,200 A.D. In that time period technetium-99 and iodine-129 are the principal contaminants of interest. After about 10,200 A.D. uranium begins to dominate as the principal contaminant in groundwater. The highest percentages of the MCL for uranium are given in Table 3.12.

---

(a) Maximum contaminant levels (MCLs), defined in 40 CFR 141, apply to public drinking water supplies. Although groundwater downgradient of Hanford Solid Waste disposal sites currently is not a source for public drinking water, the MCLs provide a useful benchmark against which to compare estimated contaminant levels.

**Table 3.11.** Highest Percentage of Maximum Contaminant Levels to the Year 12,050 A.D.<sup>(a,b)</sup>

<b>Hanford Only Waste Volume</b>																				
<b>Alternative</b>	<b>200 W Well Location</b>				<b>ERDF Well Location</b>				<b>200E NW Well Location</b>				<b>200 E SE Well Location</b>				<b>River Well Location</b>			
	I-129	Tc-99	<b>Total</b>	Yr AD	I-129	Tc-99	<b>Total</b>	Yr AD	I-129	Tc-99	<b>Total</b>	Yr AD	I-129	Tc-99	<b>Total</b>	Yr AD	I-129	Tc-99	<b>Total</b>	Yr AD
<b>Group A</b>	56	1	<b>57</b>	2330	Not applicable				52	0.3	<b>52</b>	2170	2	2	<b>4</b>	12,050	6	2	<b>8</b>	2320
<b>Group B</b>	56	1	<b>57</b>	2330					52	0.3	<b>52</b>	2170	Not applicable				6	2	<b>8</b>	2320
<b>Group C</b>	56	1	<b>57</b>	2330					52	0.3	<b>52</b>	2170	2	2	<b>4</b>	12,050	6	2	<b>8</b>	2320
<b>Group D<sub>1</sub></b>	56	1	<b>57</b>	2330					52	0.3	<b>52</b>	2170	26	14	<b>40</b>	3500	6	4	<b>10</b>	2320
<b>Group D<sub>2</sub></b>	56	1	<b>57</b>	2330					52	0.3	<b>52</b>	2170	Not applicable				7	5	<b>12</b>	3730
<b>Group D<sub>3</sub></b>	56	1	<b>57</b>	2330	41	27	<b>68</b>	3860	52	0.3	<b>52</b>	2170					6	3	<b>9</b>	2320
<b>Group E<sub>1</sub></b>	56	1	<b>57</b>	2330	5	7	<b>12</b>	12,050	52	0.3	<b>52</b>	2170					7	5	<b>12</b>	3720
<b>Group E<sub>2</sub></b>	56	1	<b>57</b>	2330	5	7	<b>12</b>	12,050	52	0.3	<b>52</b>	2170	28	18	<b>46</b>	3500	6	3	<b>9</b>	2320
<b>Group E<sub>3</sub></b>	56	1	<b>57</b>	2330	40	27	<b>67</b>	3860	52	0.3	<b>52</b>	2170	2	2	<b>4</b>	12,050	6	3	<b>8</b>	2320
<b>No Action</b>	58	1	<b>59</b>	2330	Not applicable				52	0.3	<b>52</b>	2170	2	2	<b>4</b>	12,050	8	0.2	<b>8</b>	2330
<b>Upper Bound Waste Volume</b>																				
<b>Alternative</b>	<b>200 W Well Location</b>				<b>ERDF Well Location</b>				<b>200E NW Well Location</b>				<b>200 E SE Well Location</b>				<b>River Well Location</b>			
	I-129	Tc-99	<b>Total</b>	Yr AD	I-129	Tc-99	<b>Total</b>	Yr AD	I-129	Tc-99	<b>Total</b>	Yr AD	I-129	Tc-99	<b>Total</b>	Yr AD	I-129	Tc-99	<b>Total</b>	Yr AD
<b>Group A</b>	56	1	<b>57</b>	2330	Not applicable				52	0.3	<b>52</b>	2170	2	2	<b>4</b>	12,050	6	2	<b>8</b>	2320
<b>Group B</b>	56	1	<b>57</b>	2330					52	0.3	<b>52</b>	2170	Not applicable				7	2	<b>9</b>	3560
<b>Group C</b>	56	1	<b>57</b>	2330					52	0.3	<b>52</b>	2170	2	2	<b>4</b>	12,050	6	4	<b>10</b>	2320
<b>Group D<sub>1</sub></b>	56	1	<b>57</b>	2330					52	0.3	<b>52</b>	2170	26	15	<b>41</b>	3500	6	5	<b>11</b>	2320
<b>Group D<sub>2</sub></b>	56	1	<b>57</b>	2330					52	0.3	<b>52</b>	2170	Not applicable				7	5	<b>12</b>	3700
<b>Group D<sub>3</sub></b>	56	1	<b>57</b>	2330	41	28	<b>69</b>	3860	52	0.3	<b>52</b>	2170					6	4	<b>10</b>	2320
<b>Group E<sub>1</sub></b>	56	1	<b>57</b>	2330	5	7	<b>12</b>	12,050	52	0.3	<b>52</b>	2170					7	5	<b>12</b>	3690
<b>Group E<sub>2</sub></b>	56	1	<b>57</b>	2330	5	7	<b>12</b>	12,050	52	0.3	<b>52</b>	2170	28	19	<b>47</b>	3500	6	3	<b>9</b>	2320
<b>Group E<sub>3</sub></b>	56	1	<b>57</b>	2330	41	28	<b>69</b>	3860	52	0.3	<b>52</b>	2170	2	2	<b>4</b>	12,050	6	4	<b>10</b>	2320
<b>No Action</b>	Not applicable																			
(a) MCL for Tc-99 is 900 pCi/L; MCL for I-129 is 1 pCi/L.																				
(b) Due to rounding, some of the total values do not add exactly.																				

**Table 3.12.** Highest Percentage of Maximum Contaminant Levels from 10,200 to 12,050 A.D. – All Due to Uranium<sup>(a)</sup>

Alternative	Hanford Only Waste Volume					Upper Bound Waste Volume				
	200 W Well	ERDF Well	200 E NW Well	200 E SE Well	River Well	200 W Well	ERDF Well	200 E NW Well	200 E SE Well	River Well
	%	%	%	%	%	%	%	%	%	%
<b>Group A</b>	<0.1	NA	0.2	1	<0.1	<0.1	NA	0.3	1	<0.1
<b>Group B</b>	3		3	NA	<0.1	4		3	NA	0.1
<b>Group C</b>	<0.1		0.2	1	<0.1	<0.1		0.3	1	<0.1
<b>Group D<sub>1</sub></b>	<0.1		0.1	1	<0.1	0.1		0.2	1	<0.1
<b>Group D<sub>2</sub></b>	<0.1		1	NA	<0.1	0.1		1	NA	<0.1
<b>Group D<sub>3</sub></b>	<0.1	4	0.1		<0.1	0.1	4	0.2		<0.1
<b>Group E<sub>1</sub></b>	<0.1	4	0.3		<0.1	0.1	4	0.6		<0.1
<b>Group E<sub>2</sub></b>	<0.1	4	0.1	0.2	<0.1	0.1	4	0.2	0.3	<0.1
<b>Group E<sub>3</sub></b>	<0.1	<0.1	0.1	1	<0.1	0.1	<0.1	0.2	1	<0.1
<b>No Action</b>	<0.1	NA	5	1	0.3	Not applicable				

(a) MCL for uranium is 30 micrograms per liter.

Under all the alternative groups (including the No Action Alternative), the highest potential impacts to groundwater quality were estimated from releases of long-lived technetium-99, iodine-129, and uranium isotopes. Using the sum-of-fractions method, the total concentrations of technetium-99 and iodine-129, when combined, would reach a maximum of 69 percent of the benchmark drinking water standard in the 200 Areas for Alternative Groups D<sub>3</sub> and E<sub>3</sub> at the ERDF 1-kilometer line of analysis for the Upper Bound waste volume in about the year 3900 A.D. Combined technetium-99 and iodine-129 concentrations would be even further below benchmark standards by the time they reached the Columbia River line of analysis for all alternative groups (including the No Action Alternative). For the No Action Alternative, uranium concentrations reached up to about 5 percent of the benchmark standard at the 200 East Area line of analysis about 10,000 years after closure. None of the alternatives would result in concentrations of uranium exceeding 0.3 percent of the benchmark standard at the river line of analysis.

The reduction in impacts associated with groundwater as presented in this FEIS compared with those presented in the revised draft HSW EIS reflect additional mitigation to reduce the release and transport of contaminants, resulting from a greater amount of MLLW assumed to be disposed of in higher integrity containment, such as HICs, macroencapsulation, or in-trench grouting. Most variation in groundwater radionuclide concentrations among the alternative groups resulted from different proposed configurations and locations for new disposal facilities, and there were essentially no differences between the Hanford Only and Upper Bound waste volumes.

LLW disposed of before October 1987 may contain hazardous chemical constituents, but no specific requirements existed to account for or report the content of hazardous chemical constituents in this category of LLW. As a consequence, analysis of these constituents and estimated impacts based on the limited amount of information on estimated inventories and waste disposal locations would be subject to



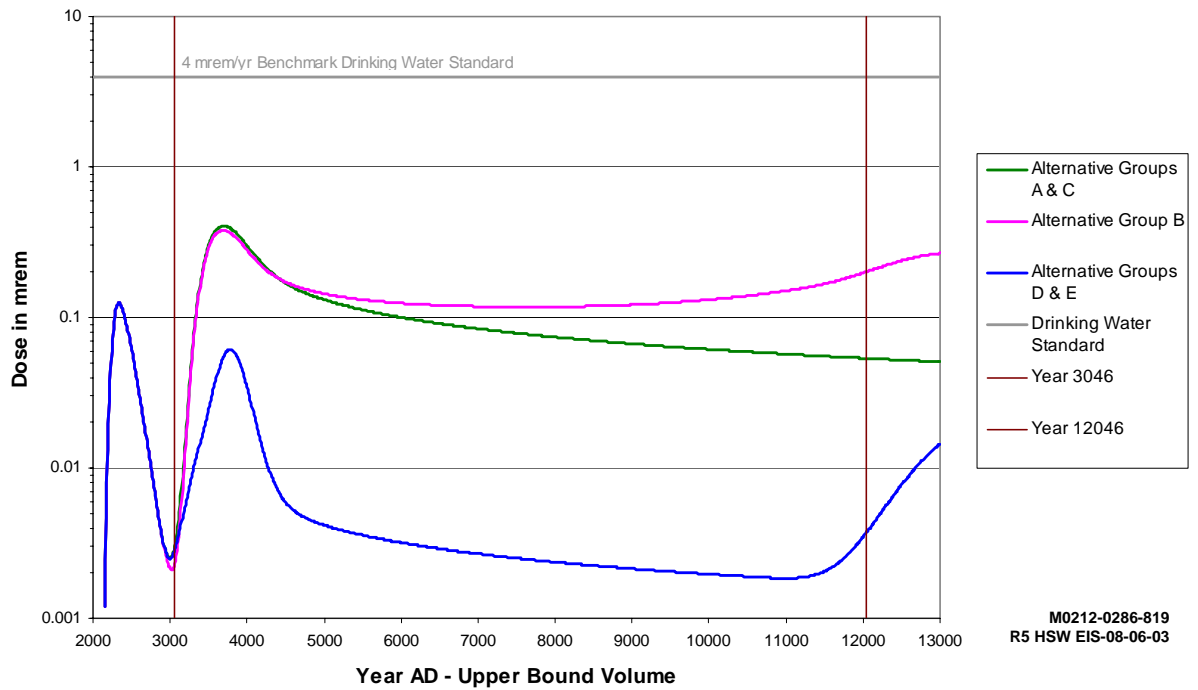
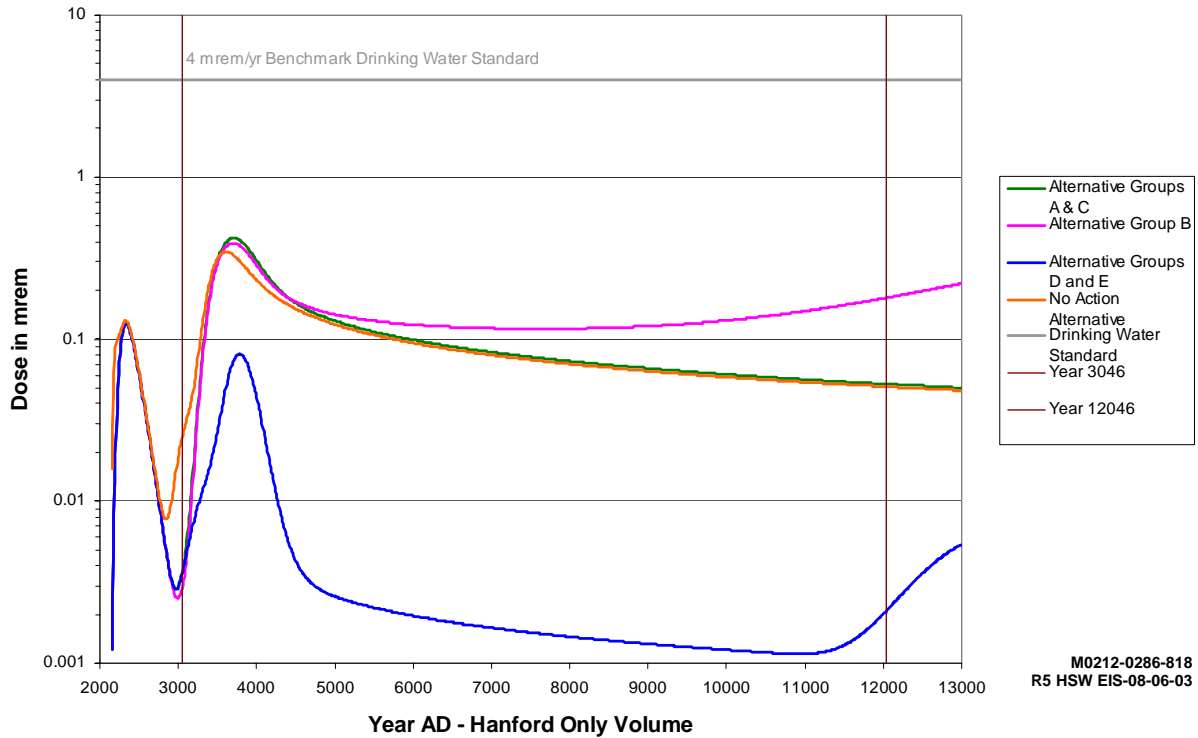
greater uncertainty at this time. (Additional discussion on uncertainties is presented in Section 3.5.) A screening evaluation of hazardous chemicals potentially disposed of before October 1987 in the Low Level Burial Grounds did not identify any chemicals that would be likely to exceed the 40 CFR 141 maximum contaminant levels over the period of analysis. Wastes containing hazardous chemicals disposed of after October 1987 would have been treated according to regulatory requirements, and they are not expected to present a substantial risk for groundwater contamination.

Another measure of water quality for purposes of comparing the alternatives is taken as the annual dose to an individual from drinking 2 liters per day of groundwater from hypothetical wells located along the lines of analysis described in this section. As a benchmark, the estimated doses are compared with the 4 millirem-per-year standard for public drinking water systems operated by DOE (DOE 1993), although groundwater beneath the Hanford Site is not currently used as a source for public drinking water. These doses are based on inventories by activity presented in Appendix B, groundwater transport analysis as described in Section 5.3 and Volume II, Appendix G, and dose conversion factors based on Federal Guidance Reports 11 and 12 (Eckerman et al. 1988; Eckerman and Ryman 1993), details of which are presented in Volume II, Appendix F. The latter are presented in plots of maximum annual drinking water dose as a function of time in Figures 3.4 through 3.8.<sup>(a)</sup> Doses calculated using this method do not correspond exactly to the 4-mrem/yr whole body or maximum organ doses used to calculate MCLs in 40 CFR 141.

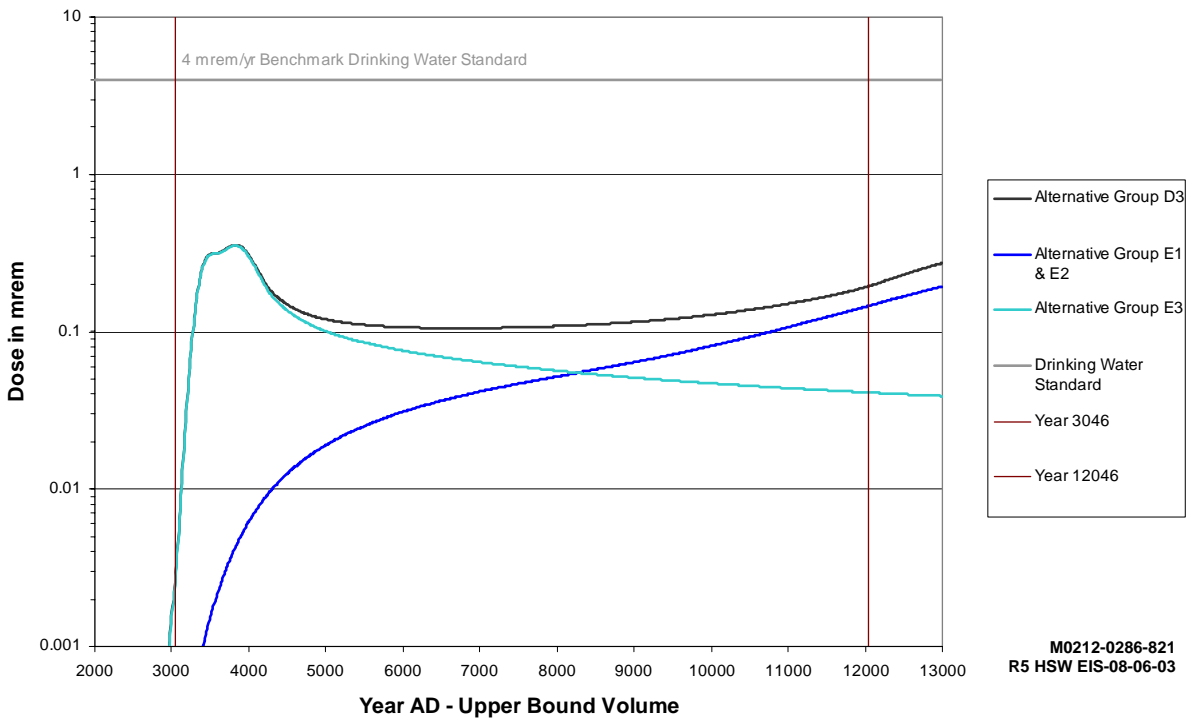
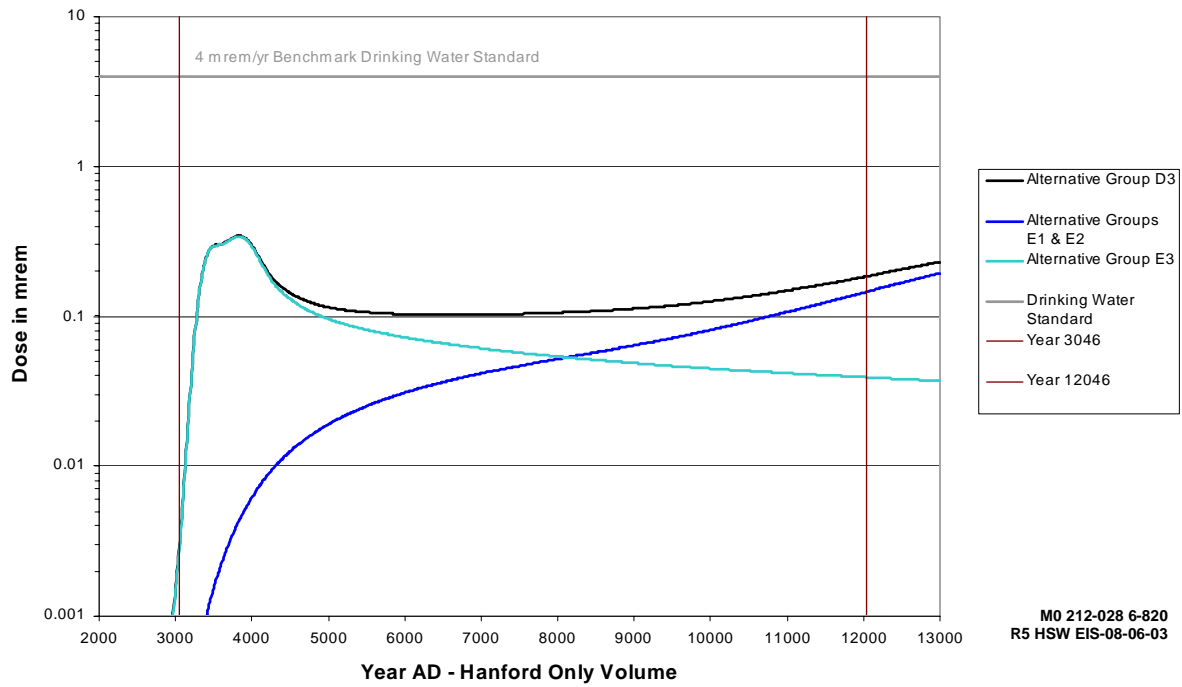
Estimated peak doses from drinking groundwater containing combined radionuclide concentrations at 1 kilometer from the Hanford solid waste disposal facilities, for any of the alternatives and waste volumes disposed of, would fall below 1 millirem per year over the 10,000-year period of analysis. The corresponding doses estimated adjacent to the Columbia River would be less than 0.1 millirem per year for the period of analysis. The current drinking water dose at the Richland Municipal Water Intake is about 0.1 mrem/yr. The additional dose from HSW was determined to be less than 0.00001 mrem/yr over the 10,000-year period of analysis. Results from modeling indicate potential increases in the dose near the end of the 10,000-year period because of the arrival of uranium in groundwater.

---

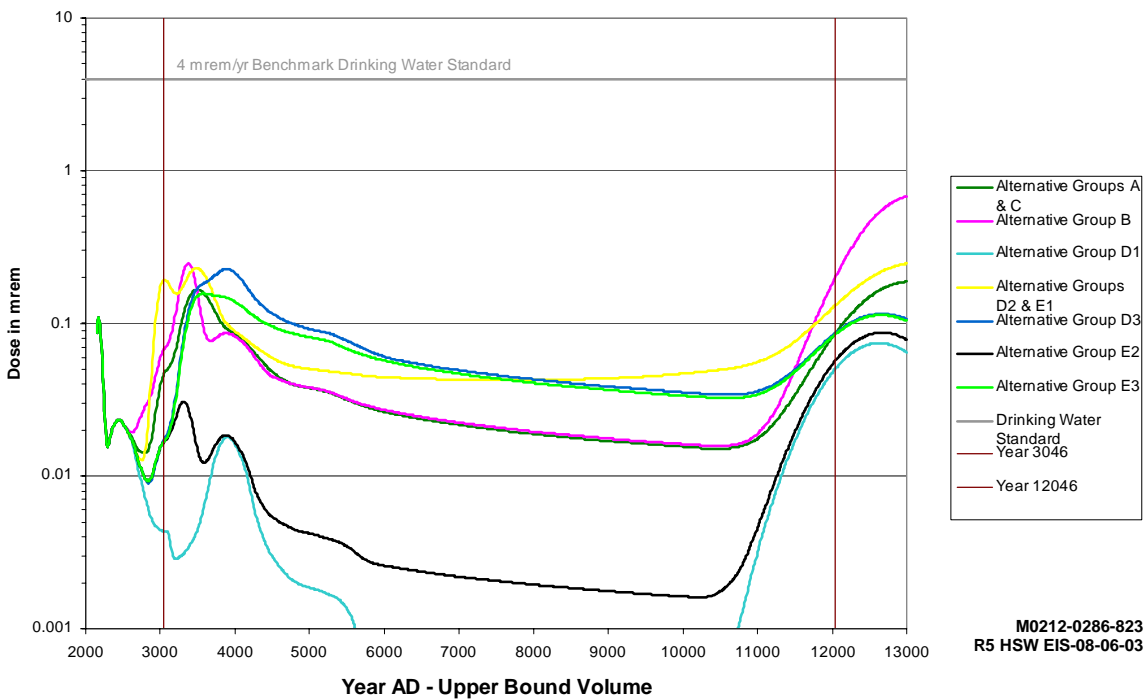
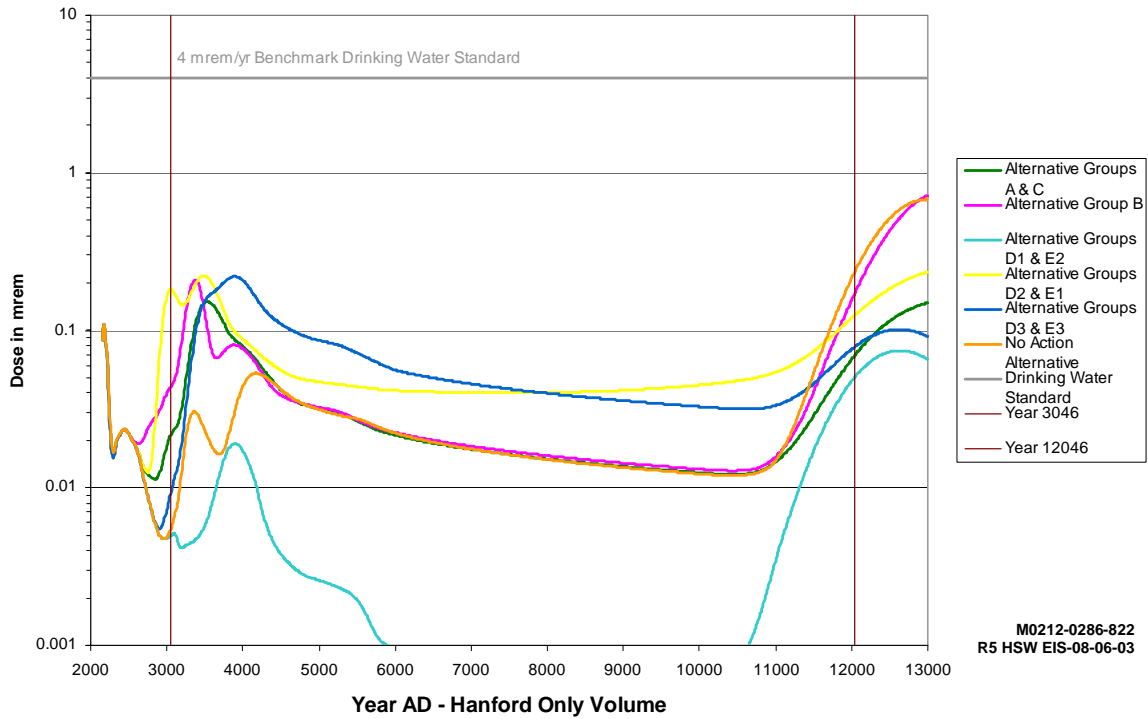
(a) The period of analysis is 10,000 years after 2046, and the plots would end at 12,046; however, the plots are constrained by the software to the next whole millennium.



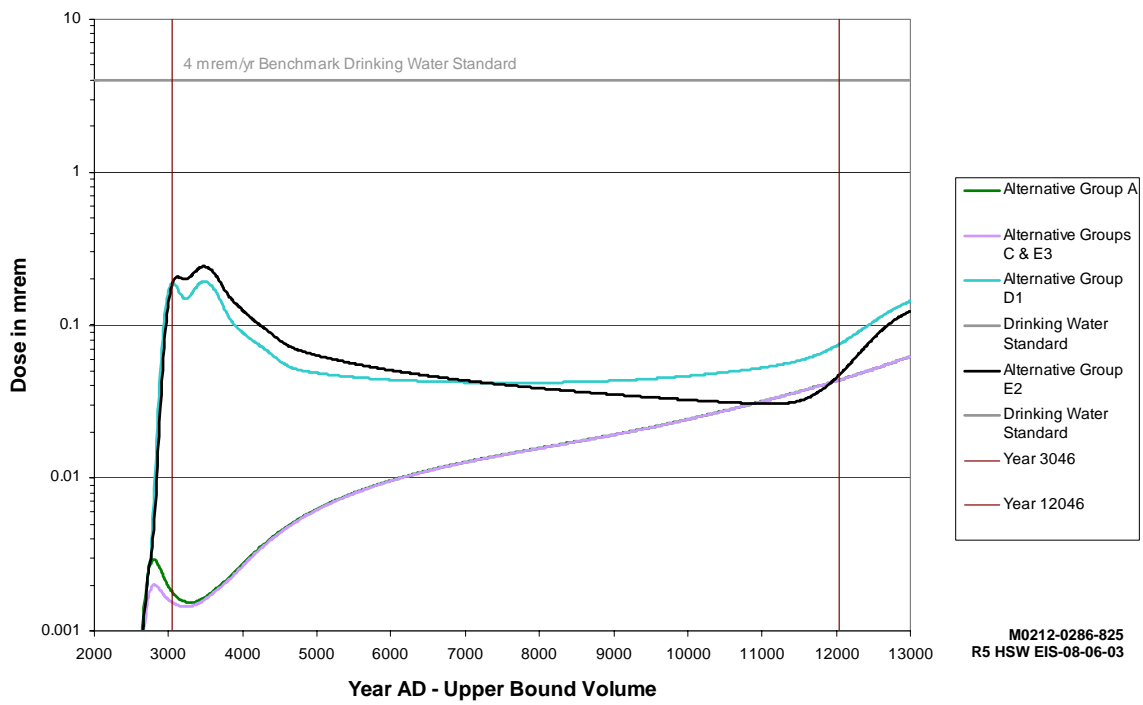
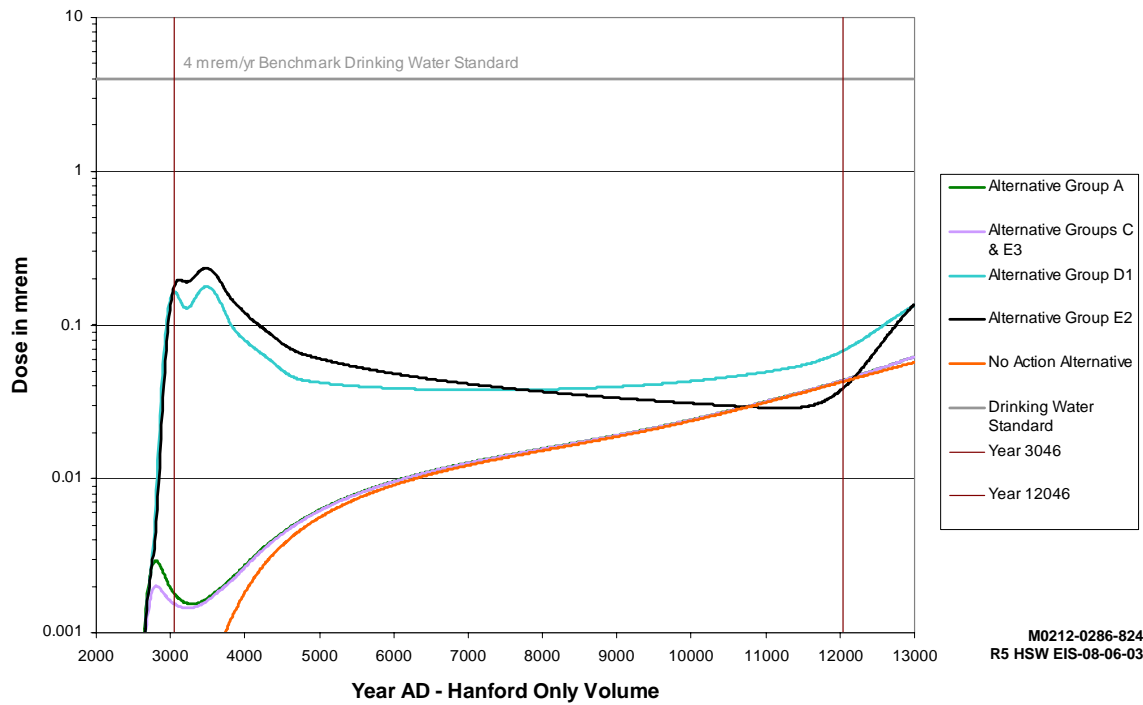
**Figure 3.4.** Hypothetical Annual Dose from Drinking Water Containing Maximum Concentrations of Radionuclides in Groundwater at 1 km Downgradient from the 200 West Area Disposal Facilities as a Function of Calendar Year – Hanford Only and Upper Bound Waste Volumes



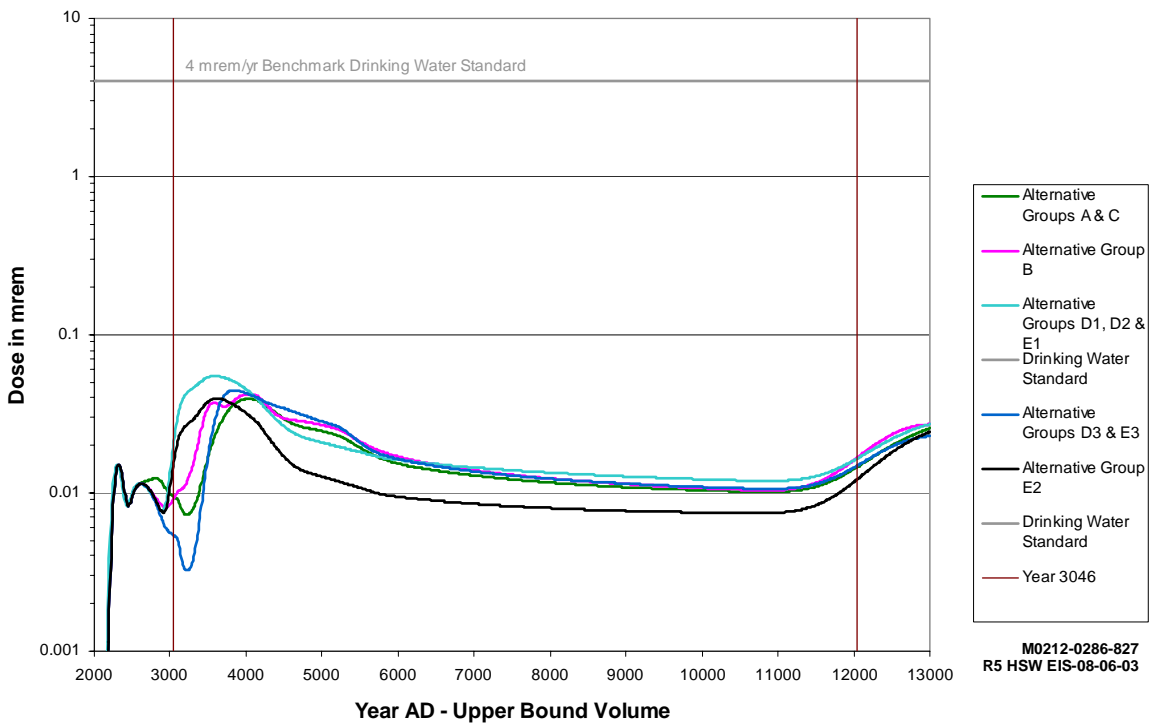
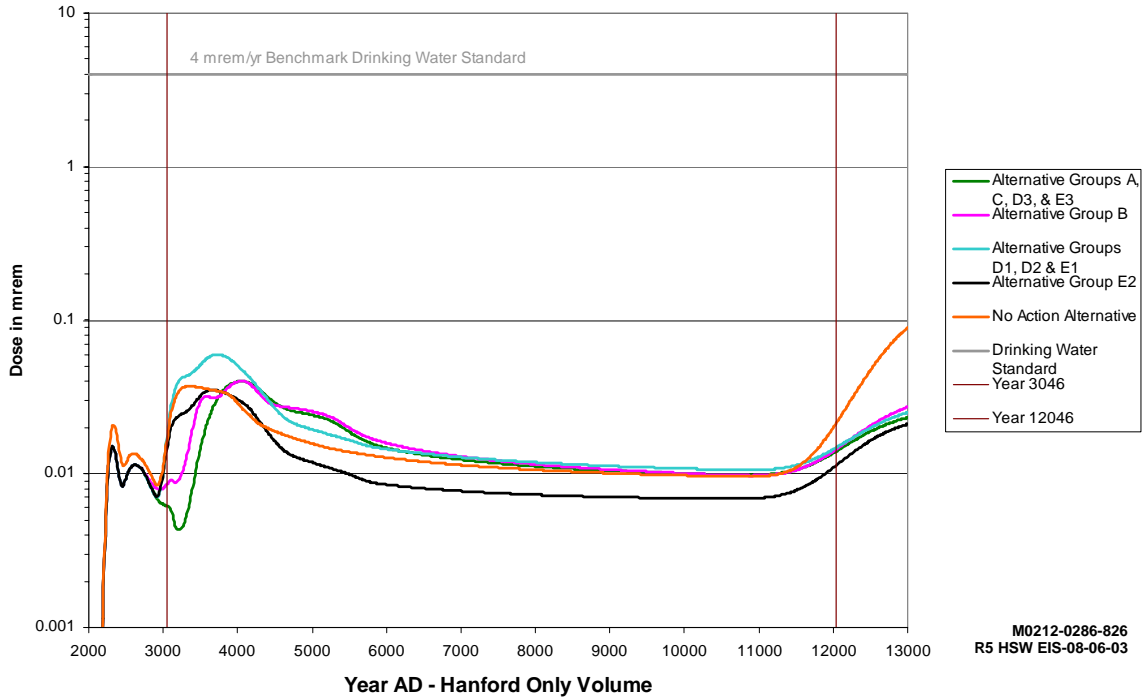
**Figure 3.5.** Hypothetical Annual Dose from Drinking Water Containing Maximum Concentrations of Radionuclides in Groundwater at 1 km Downgradient from ERDF as a Function of Calendar Year – Hanford Only and Upper Bound Waste Volumes



**Figure 3.6.** Hypothetical Annual Dose from Drinking Water Containing Maximum Concentrations of Radionuclides in Groundwater at 1 km Northwest Downgradient from the 200 East Area as Disposal Facilities as Function of Calendar Year – Hanford Only and Upper Bound Waste Volumes



**Figure 3.7.** Hypothetical Annual Dose from Drinking Water Containing Maximum Concentrations of Radionuclides in Groundwater at 1 km Downgradient Southeast from the 200 East Area Disposal Facilities as a Function of Calendar Year – Hanford Only and Upper Bound Waste Volumes



**Figure 3.8.** Hypothetical Annual Dose from Drinking Water Containing Maximum Concentrations of Radionuclides in Groundwater Near the Columbia River as a Function of Calendar Year – Hanford Only and Upper Bound Waste Volumes

### 3.4.4 Geologic Resources

Although large quantities of gravel, silt/loam, and basalt would be needed for capping waste disposal facilities upon closure, these resources are readily available in the Area C borrow pit. A comparison among the alternatives of quantities that would be needed is shown in Table 3.13. As a result of refined calculation of resource needs based on the Technical Information Document (FH 2004), the need for gravel and sand, silt/loam, and basalt for action alternative groups increased by factors of approximately, 1.8, 2.6, and 1.2, respectively, over those reported in the revised draft HSW EIS.

**Table 3.13.** Comparison of Commitments of Geologic Resources, Millions of m<sup>3(a)</sup>

Alternative	Hanford Only Waste Volume	Lower Bound Waste Volume	Upper Bound Waste Volume
Alternative Group A	4.0	4.0	4.2
Alternative Group B	4.4	4.5	4.9
Alternative Group C	3.7	3.8	4.0
Alternative Groups D <sub>1</sub> and D <sub>3</sub>	3.7	3.8	3.9
Alternative Group D <sub>2</sub>	3.9	3.9	4.0
Alternative Group E	3.7	3.7	3.8
No Action Alternative	2.7	2.7	Not applicable
(a) 1 m <sup>3</sup> = about 1.3 yd <sup>3</sup> .			

### 3.4.5 Ecological Resources

Impacts on ecological resources, other than disturbance of shrub-steppe habitat, were determined to be low and sufficiently similar among the alternative groups (including the No Action Alternative) that they would not be expected to be an important discriminator in the alternative selection process. Disturbance of shrub-steppe habitat would be related to alternative groups making use of the near-PUREX disposal facility, which is in an area that was not burned over in the 24 Command Fire of June 2000. There, the area of disturbance ranged from zero in the case of Alternative Groups B, D<sub>2</sub>, D<sub>3</sub>, and E<sub>1</sub> to 32 ha (79 ac) for Alternative Group A. Other alternative groups and the No Action Alternative were intermediate with 5 to 25 ha (12 to 62 ac) of disturbance depending on the waste volume disposed of (see Table 3.7). Conclusions regarding potential impacts on terrestrial biota at the disposal facility near PUREX were based on spring/summer surveys conducted from 1998 to 2002. Conclusions regarding potential impacts on aquatic and riparian biota near and in the Columbia River were based on an ecological risk assessment of potential future releases from waste sites through groundwater to the river. Details of the analysis are presented in Section 5.5 with additional information in Volume II, Appendix I.

### 3.4.6 Socioeconomics and Environmental Justice

Implementation of any of the HSW EIS alternative groups (including the No Action Alternative) would have small and barely differentiable impacts on local socioeconomic infrastructure, including housing, schools, medical support, and transportation. Details of the analysis are presented in Section 5.6. No particular distinction was made among any of the alternatives for impacts on environmental justice (see Section 5.13).

### 3.4.7 Cultural, Aesthetic, and Scenic Resources

The principal potential for impacts on cultural resources in implementing any of the alternative groups (including the No Action Alternative) would be associated with disturbance of the surface and near surface portions of the Area C borrow pit. Although archeological sites might be found in Area C, a recent field reconnaissance failed to reveal any archeological sites or artifacts on the surface. Because construction would be halted in the event that an artifact of possible cultural significance is found and will remain so until a professional evaluation is made, it is unlikely that impacts to cultural resources would be an important discriminator among the alternatives. Details of the analysis are presented in Sections 5.7 and Volume II, Appendix K.

No particular distinction was made among any of the alternative groups for impacts on aesthetic and scenic resources; the most noticeable change would be the potential impact on the viewshed from nearby prominences as a result of obtaining capping materials from Area C (see Section 5.12).

### 3.4.8 Transportation

The measure of impacts from transportation for comparison among the alternatives was taken as the number of fatalities resulting from transport of wastes and construction materials. Those impacts include offsite transport of some MLLW for treatment at the Oak Ridge Reservation in Alternative Groups A, C, D, and E. MLLW treatment would be performed onsite in Alternative Group B. The values for the Hanford Only waste volume are presented in Table 3.14. Details of the transportation analysis are presented in Section 5.8 and Volume II, Appendix H.

Transport of wastes from offsite is the same for all alternative groups. The potential impacts of offsite transportation previously were evaluated in the WM PEIS and the WIPP SEIS-II (DOE 1997a and DOE 1997b, respectively). However, impacts of transporting waste from offsite to the Hanford Site were re-evaluated for the final HSW EIS using updated codes and the year 2000 Census data. Impacts of nationwide transport of wastes are presented in Table 3.7, Section 5.8, and Volume II, Appendix H. A comparison of results of the transportation analyses from the WM PEIS, the WIPP SEIS-II, and the final HSW EIS are presented in Section H.9 of Appendix H in Volume II.

Potential impacts within the states of Oregon and Washington that might occur from shipping waste to and from the Hanford Site were analyzed and are summarized in Table 3.15. As shown in the table, transport of waste from offsite generators and transport of Hanford TRU waste to WIPP might result in one accident in Oregon and none in Washington for the Lower Bound waste volume and five accidents in Oregon and two in Washington for the Upper Bound waste volume. One accident fatality might result during transport through Oregon and Washington for the Upper Bound waste volume.

Transport of TRU waste to WIPP for Alternative Groups A through E might result in 17 accidents and 1 fatality; for the No Action Alternative, 8 accidents and no fatalities.



**Table 3.14.** Summary Comparison of Potential Radiological and Non-Radiological Transportation Impacts – Hanford Only Waste Volumes (excluding TRU waste sent to WIPP)

Alternative	Radiological			Non-Radiological		
	Incident-Free		Accidents	Number of Accidents	Accident Fatalities	Emissions Fatalities
	Crew – Fatalities	Public – Fatalities	Accidents Fatalities			
Alternative Groups A, C, D, and E <sup>(a)</sup>	0 (0.038)	0 (0.25)	0 (1.3E-5)	3 (2.6)	0 (0.084)	0 (0.18)
Alternative Group B <sup>(b)</sup>	0 (0.064)	1 (0.77)	0 (1.0E-5)	2 (1.6)	0 (0.068)	0 (0.078)
No Action Alternative <sup>(c)</sup>	0 (0.012)	0 (0.093)	0 (1.2E-5)	1 (1.2)	0 (0.050)	0 (0.047)

**Note:** Public includes non-involved workers. Numbers in parentheses are the calculated values. Accidents and fatalities occur as whole numbers and calculated values are rounded to whole numbers.

(a) The impacts in these Alternative Groups are for the Hanford Only waste volume case. The differences between this case and the Upper and Lower Bound waste volume case of additional offsite-generated waste are shown in Table 3.15, for Oregon and Washington only. Impacts of nationwide transport of wastes are presented in Table 3.7, Section 5.8, and Appendix H.

(b) Offsite shipments for waste treatment are minimal in Alternative Group B for all waste volume cases.

(c) There are no offsite shipments for waste treatment associated with the No Action Alternative.

**Table 3.15.** Potential Impacts in Oregon and Washington by State from Shipments of Solid Wastes to and from Hanford<sup>(a)</sup>

Waste Volume/Alternative	Radiological Impacts, LCFs			Non-Radiological Impacts		
	Routine Transport		Accidents	Number of Accidents	Number of Fatalities	Emissions LCFs
	Worker	Public	Public			
<b>Oregon State</b>						
Hanford Only – Action Alternatives <sup>(b)</sup>	0 (0.026)	0 (0.34)	0 (4.2E-4)	1 (1.2)	0 (0.11)	0 (0.023)
Lower Bound – All Alternatives	0 (0.029)	0 (0.37)	0 (7.7E-4)	1 (1.4)	0 (0.14)	0 (0.037)
Upper Bound – Action Alternatives	0 (0.074)	1 (0.59)	0 (4.7E-3)	5 (5.1)	0 (0.48)	0 (0.16)
Hanford Only – No Action Alternative <sup>(b)</sup>	0 (0.013)	0 (0.11)	0 (2.2E-4)	1 (0.60)	0 (0.057)	0 (0.012)
<b>Washington State</b>						
Hanford Only – Action Alternatives <sup>(b)</sup>	0 (8.0E-3)	0 (0.11)	0 (1.3E-4)	0 (0.38)	0 (8.2E-3)	0 (0.036)
Lower Bound – All Alternatives	0 (8.9E-3)	0 (0.11)	0 (2.1E-4)	0 (0.46)	0 (9.7E-3)	0 (0.042)
Upper Bound – Action Alternatives	0 (0.022)	0 (0.17)	0 (1.2E-3)	2 (1.6)	0 (0.034)	0 (0.15)
Hanford Only – No Action Alternative <sup>(b)</sup>	0 (4.3E-3)	0 (0.036)	0 (7.0E-5)	0 (0.20)	0 (4.3E-3)	0 (0.018)

(a) Radiological impacts (incident-free and accident) are expressed in units of LCFs. Non-radiological accident impacts are expressed as the expected number of accidents and the resulting physical trauma fatalities. Non-radiological emissions impacts are expressed as LCFs.

(b) TRU wastes to WIPP.

One to four accidents were calculated to occur during transport of construction and capping materials for Alternative Groups A through E, and four accidents were estimated for the No Action Alternative. No fatalities were forecast in any case.

### **3.4.9 Noise**

Because all alternatives would involve essentially the same activities, noise levels produced by those activities at any given point in time would be essentially the same. Noise was not considered to be an important impact element because of distance to public receptors. Wildlife that might be disturbed by noise near the Area C borrow pit likely would move to more distant locations. Details of the analysis of noise are presented in Section 5.9 and Volume II, Appendix J. Based on the level of activity associated with waste management operations and the location of the activities within the Hanford Site, noise levels are predicted to be well within allowable limits at locations occupied by members of the public.

### **3.4.10 Resource Commitments**

Resources committed to implementing the various alternative groups (including the No Action Alternative) would include land; the vadose zone beneath the disposal facilities; groundwater beneath the disposal sites and on to where it empties into the Columbia River; and various amounts of fossil fuel, electricity, steel, concrete, gravel, sand, gravel, silt/loam, basalt, water, and other materials. Land use and geologic resources were described previously (Tables 3.9 and 3.13). Comparison of fossil fuel commitments among the alternatives is provided in Table 3.16. Alternative Groups A and B and the No Action Alternative have generally higher demand for fossil fuels than the other alternative groups because of additional construction and operation required. Details of the analysis of resource commitments are presented in Section 5.10.

### **3.4.11 Human Health and Safety**

Comparison of human health and safety among the alternatives is expressed in terms of worker dose, dose to the public from atmospheric releases, accidents during the operational period, and long-term impacts via the groundwater pathway in the post-closure period. Details of the analyses are provided in Section 5.11 and Volume II, Appendix F. Intruder scenarios and consequences are essentially the same for all alternative groups. The exception would be for the basement excavation scenario in the No Action Alternative where only Trenches 31 and 34 containing MLLW are capped. The depth of capping material would be expected to preclude the occurrence of that scenario for those wastes.

**Table 3.16.** Comparison of Fossil Fuel Commitments Among the Alternatives

Alternative	Diesel, m <sup>3(b)</sup>			Gasoline, m <sup>3</sup>			Propane, tonnes <sup>(a)</sup>		
	Hanford Only Waste Volume	Lower Bound Waste Volume	Upper Bound Waste Volume	Hanford Only Waste Volume	Lower Bound Waste Volume	Upper Bound Waste Volume	Hanford Only Waste Volume	Lower Bound Waste Volume	Upper Bound Waste Volume
Alternative Group A	132,900	132,900	133,700	260	260	270	12,700	12,700	19,300
Alternative Group B	136,600	136,700	140,600	340	340	430	23,500	23,500	38,300
Alternative Group C	65,900	65,900	66,700	260	260	270	12,700	12,700	19,300
Alternative Group D	65,900	65,900	66,700	260	260	270	18,800	20,300	27,800
Alternative Group E	65,900	65,900	66,700	260	260	270	18,800	20,300	27,800
No Action Alternative	188,600	188,700	Not applicable	48	50	Not applicable	3,560	3,560	Not applicable

(a) 1 tonne = about 1.1 ton.  
(b) Includes 120,100 m<sup>3</sup> for ILAW in Alternative Groups A and B, 53,100 m<sup>3</sup> for ILAW in Alternative Groups C, D, and E, and 183,400 m<sup>3</sup> for ILAW in the No Action Alternative.

**3.4.11.1 Operational Period – Normal Operations**

Radiological impacts to workers from air emissions and routine occupational radiation exposure through 2046 are compared among the alternatives in Table 3.17. No latent cancer fatalities (LCFs) would be expected from doses associated with any of the action alternatives; however, one LCF might be inferred from the No Action Alternative.

**Table 3.17.** Comparison of Worker Health Impacts

Alternative	Non-Involved Worker, mrem <sup>(a)</sup>			Occupational Exposure, person-rem <sup>(b)</sup>		
	Hanford Only Waste Volume	Lower Bound Waste Volume	Upper Bound Waste Volume	Hanford Only Waste Volume	Lower Bound Waste Volume	Upper Bound Waste Volume
Alternative Group A	0.48	0.58	0.89	765	766	774
Alternative Group B	0.48	0.58	0.89	772	773	786
Alternative Group C	0.48	0.58	0.89	765	765	773
Alternative Groups D and E	0.48	0.58	0.89	767	767	778
No Action Alternative	0.48	0.58	Not applicable	873	873	Not applicable

(a) Lifetime dose to the hypothetical maximally exposed individual (MEI) based on the industrial worker scenario.  
(b) Work force external exposure from proximity to wastes.

Radiological impacts on the public from the release of radioactive material to the atmosphere during routine operations through 2046 are compared among the alternatives in Table 3.18. (For more details, see Section 5.11.) No LCFs would be expected from the doses presented.

**Table 3.18.** Comparison of Public Health Impacts from Emissions of Radioactive Material to the Atmosphere During Routine Operations

Alternative	Population Dose, person-rem <sup>(a)</sup>			MEI Lifetime Dose, mrem <sup>(b)</sup>		
	Hanford Only Waste Volume	Lower Bound Waste Volume	Upper Bound Waste Volume	Hanford Only Waste Volume	Lower Bound Waste Volume	Upper Bound Waste Volume
Alternative Groups A, C, D, and E	0.15	0.17	0.24	0.0016	0.0018	0.0025
Alternative Group B	0.19	0.21	0.29	0.0021	0.0023	0.0032
No Action Alternative	0.10	0.12	Not applicable	0.0011	0.0013	Not applicable
(a) Collective population dose within 80 km (50 mi) based on the offsite resident gardener scenario as applied to average individuals in the population (see Appendix F).						
(b) Lifetime dose to the hypothetical MEI based on the offsite resident gardener scenario.						

### 3.4.11.2 Operational Period – Accidents

The consequences of industrial accidents on workers through 2046 are compared among the alternatives in Table 3.19.

**Table 3.19.** Comparison of Consequences of Industrial Accidents on Workers Among the Alternatives

Alternative	Total Recordable Cases		Lost Work Day Cases		Lost Work Days	
	Hanford Only and Lower Bound Waste Volumes	Upper Bound Waste Volume	Hanford Only and Lower Bound Waste Volumes	Upper Bound Waste Volume	Hanford Only and Lower Bound Waste Volumes	Upper Bound Waste Volume
Alternative Groups A, C, D, and E	620	640	260	260	8900	9200
Alternative Group B	640	660	260	270	9000	9300
No Action Alternative	770	NA	320	Not applicable	10,900	Not applicable

Impacts on public health and safety from processing chemicals through 2046 are compared among the alternatives in Table 3.20.

**Table 3.20.** Comparison of Health Impacts on the Public from Routine Atmospheric Releases of Chemicals

Alternative	Hazard Quotient <sup>(a)</sup>		Cancer Incidence <sup>(b)</sup>	
	Hanford Only and Lower Bound Waste Volumes	Upper Bound Waste Volume	Hanford Only and Lower Bound Waste Volumes	Upper Bound Waste Volume
Alternative Groups A, C, D, and E	1.1E-5	5.0E-5	1.2E-10	4.2E-10
Alternative Group B	3.8E-4	4.2E-4	7.0E-9	7.3E-9
No Action Alternative	5.3E-6	Not applicable	8.9E-11	Not applicable
(a) Peak annual hazard quotient values to the hypothetical MEI based on the offsite resident gardener scenario.				
(b) Lifetime risk of cancer incidence to the hypothetical MEI based on the offsite resident gardener scenario.				

For chemicals, there is no difference in impacts between the Hanford Only and the Lower Bound waste volumes because the difference in MLLW processing is small (0.4 percent volume difference).

No particular distinction was made among any of the alternatives for operational accidents involving either radiological or chemical materials. Details are provided in Section 5.11.

### 3.4.11.3 Post-Closure Period

Analyses in this HSW EIS include two scenarios for intrusion into waste sites soon after the time when active institutional control is assumed to be absent. These scenarios consist of drilling through the waste in constructing a well and excavation of a basement for a house. The importance of these scenarios lies in the presence of short- to intermediate-lived radionuclides that may occur in quantity. In the case of drilling, the existence of a cap over the waste is assumed to constitute no deterrence. Inasmuch as the highest concentrations of radionuclides that are used in this analysis are common to all alternatives, there would be no distinction among the alternatives based on this type of intrusion (the highest concentrations of radionuclides were determined to occur in waste previously disposed of in LLBGs). In the case of excavation for a basement, the depth to the top of the disposed waste is deep enough in all alternatives for which the waste sites are capped that the scenario is not considered credible. In the No Action Alternative where it is assumed that only the MLLW sites are capped, the depth to the top of the waste would be much less and waste could be encountered in the excavation. In any event, these intruder scenarios for the alternative groups (except the No Action Alternative) do not provide a basis for discriminating among the alternatives. Details of these intruder analyses are presented in Section 5.11.2.2 and Volume II, Appendix F.

Insights regarding the relative potential for impacts on the public over the long term may be obtained by examining the annual dose a hypothetical gardener might receive, if the individual were to intrude on the Hanford Site, drill a well (on the order of 80 to 90 m deep [about 250 ft]) into a contaminated aquifer, spread the drilling mud about the garden plot, and use the well water for both domestic and irrigation

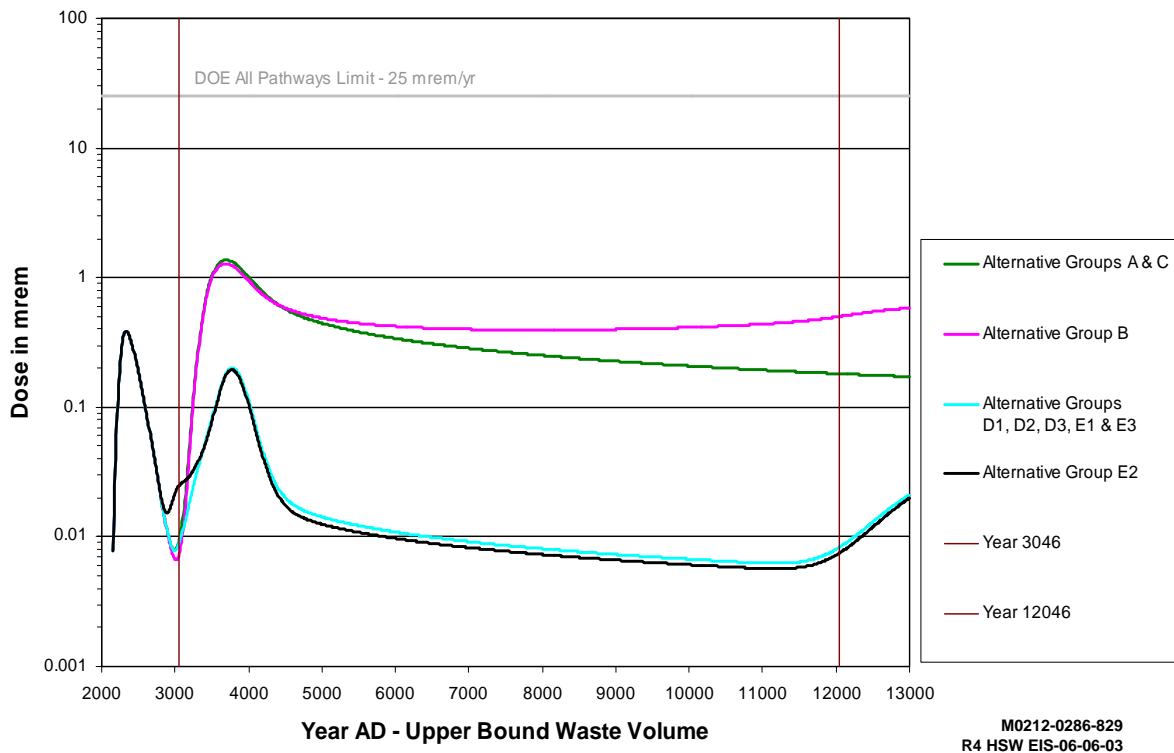
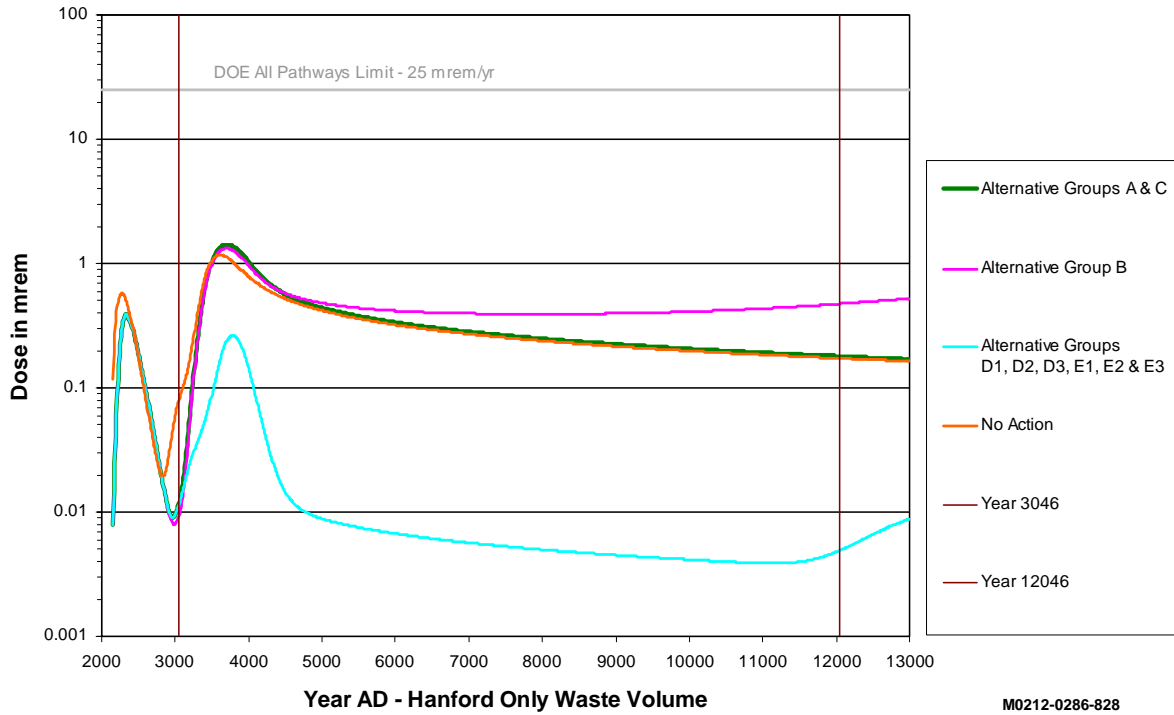
purposes. Hypothetical wells near the disposal facilities are located 1 km (0.6 mi) from the aggregated waste sites in order to capture the front of the combined plume from the individual trenches. In addition, a well is modeled near the Columbia River where an individual might drill a shallow well rather than use debris-containing water directly from the river. Plots of the annual doses to the hypothetical resident gardener are provided in Figures 3.9 through 3.13. (The vertical line represents 1,000 years after closure of the disposal facilities.) Because the plots for the Hanford Only and Lower Bound waste volumes are essentially the same, plots are provided only for the Hanford Only and Upper Bound waste volumes. As may be seen in the figures, there are differences in the annual doses over time as a function of alternative; however, the maximum values are all small compared with DOE's 25-mrem all-pathways limit and, except for the period beginning about 9,000 years after disposal, the doses are below the DOE benchmark drinking water standard of 4 mrem/yr. Most of the variation in groundwater radionuclide concentrations among the alternatives resulted from proposed locations and configurations for new disposal facilities; differences between the Hanford Only and Upper Bound waste volumes were minimal.

To account for the possibility that the hypothetical gardener had a sauna (or in the case of a Native American, a sweat lodge), the annual dose to such an individual at any time during the 10,000-year period of analysis also was estimated. Plots of the annual doses to the resident gardener are compared among the alternatives in Figures 3.14 through 3.18. The much higher doses associated with the sauna/sweat lodge scenario are attributable to inhalation of radionuclides released as a result of elevated water temperatures used in saunas or sweat lodges. For all alternatives the annual dose is at or less than the DOE benchmark 4 mrem/yr drinking water standard for the first 5,000 years. Late in the 10,000-year period there is an increase in the risk of an LCF due primarily to the arrival of uranium in groundwater. For a hypothetical 70-year residency at locations on the Central Plateau, the risk for the sauna/sweat lodge scenario would range from up to about 8 in 10,000 for the action alternatives to 200 in 10,000 for the No Action Alternative. For a location near the river, the corresponding risk would range from up to 3 in 10,000 for the action alternatives to 6 in 10,000 for the No Action Alternative.

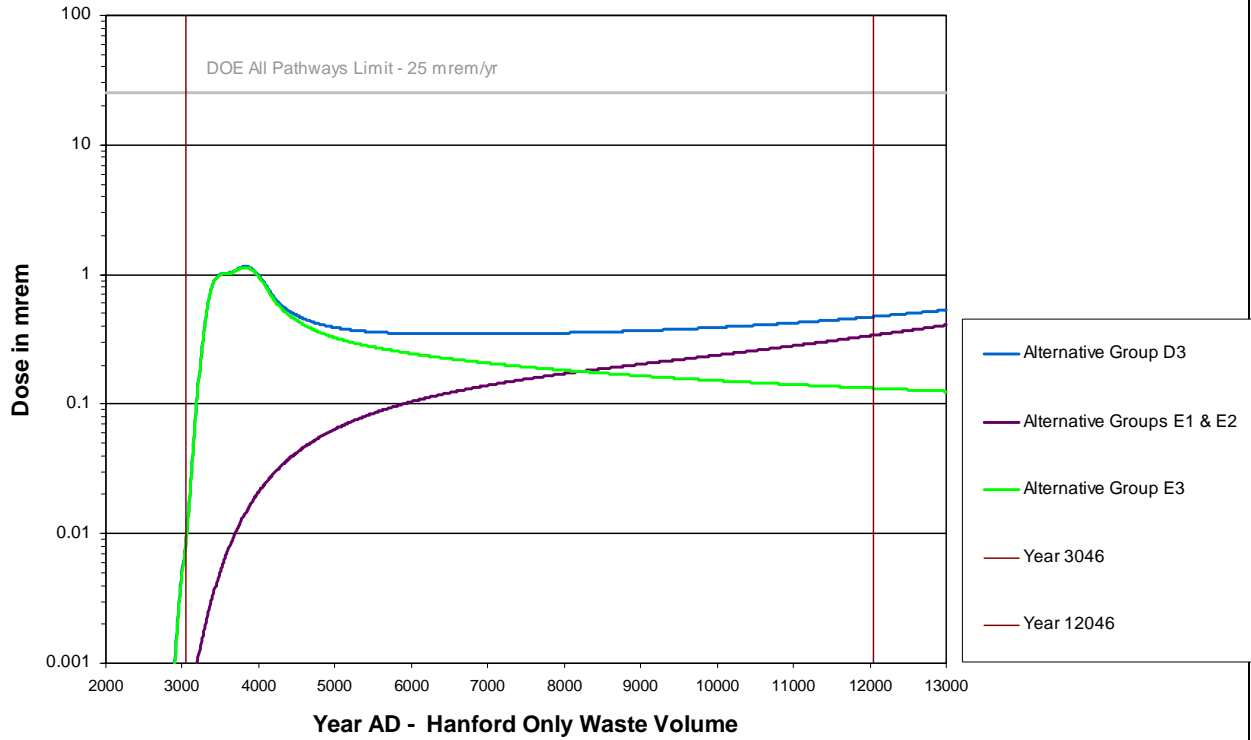
For perspective, it may be noted that a hypothetical gardener with the sauna or sweat lodge scenario, and using water drawn from the Columbia River at Priest Rapids upstream of the Hanford Site, could receive an annual dose of about 96 mrem from upstream sources of uranium (based on 5-year average measurements of the concentration of uranium in the Columbia River water at Priest Rapids [Poston et al. 2002]). Over a 70-year period at such an annual dose, the chances of an LCF would be about 4 in 1000 (see Section 5.14.6.3 for more information.)

### **3.4.12 Cumulative Impacts**

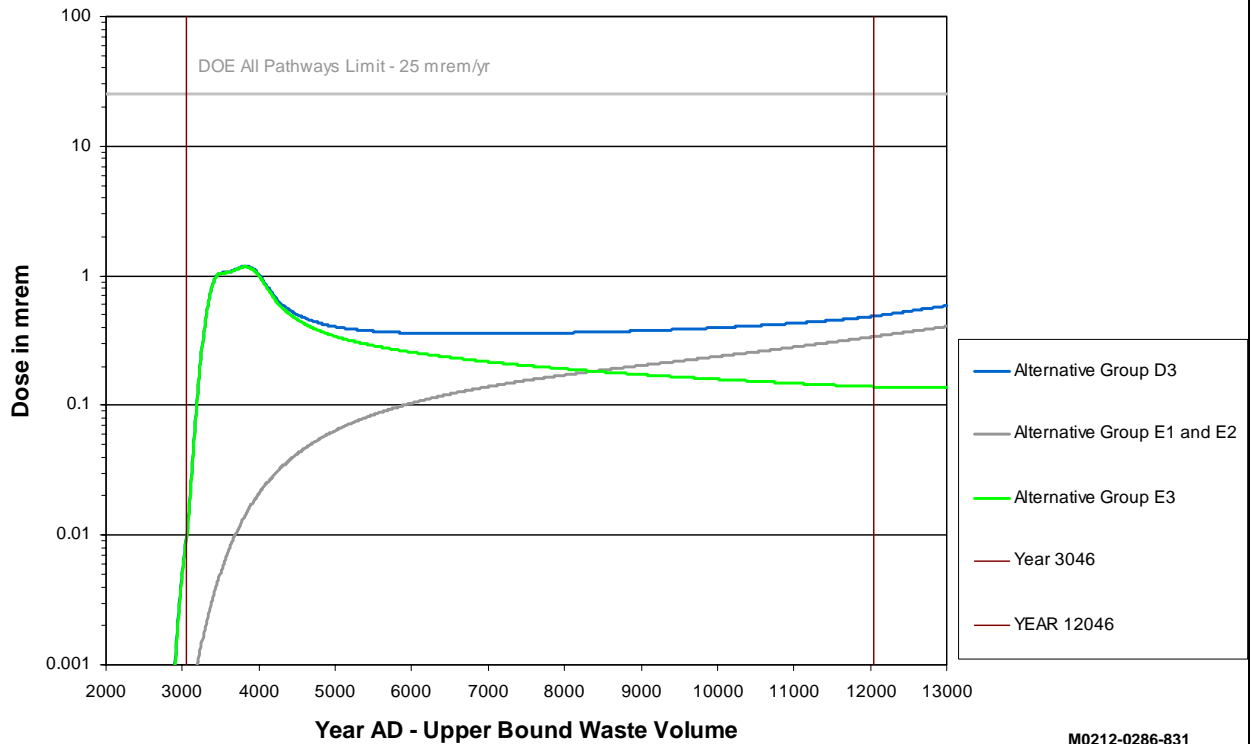
Differences in impacts from implementing the various alternative groups would be small and thus potential cumulative impacts associated with implementing the various alternative groups and waste volumes would be similar for all alternatives (see Section 5.14, Cumulative Impacts).



**Figure 3.9.** Annual Dose to a Hypothetical Resident Gardener at Various Times over 10,000 Years Using Water from a Well 1 km Downgradient from the 200 West Area



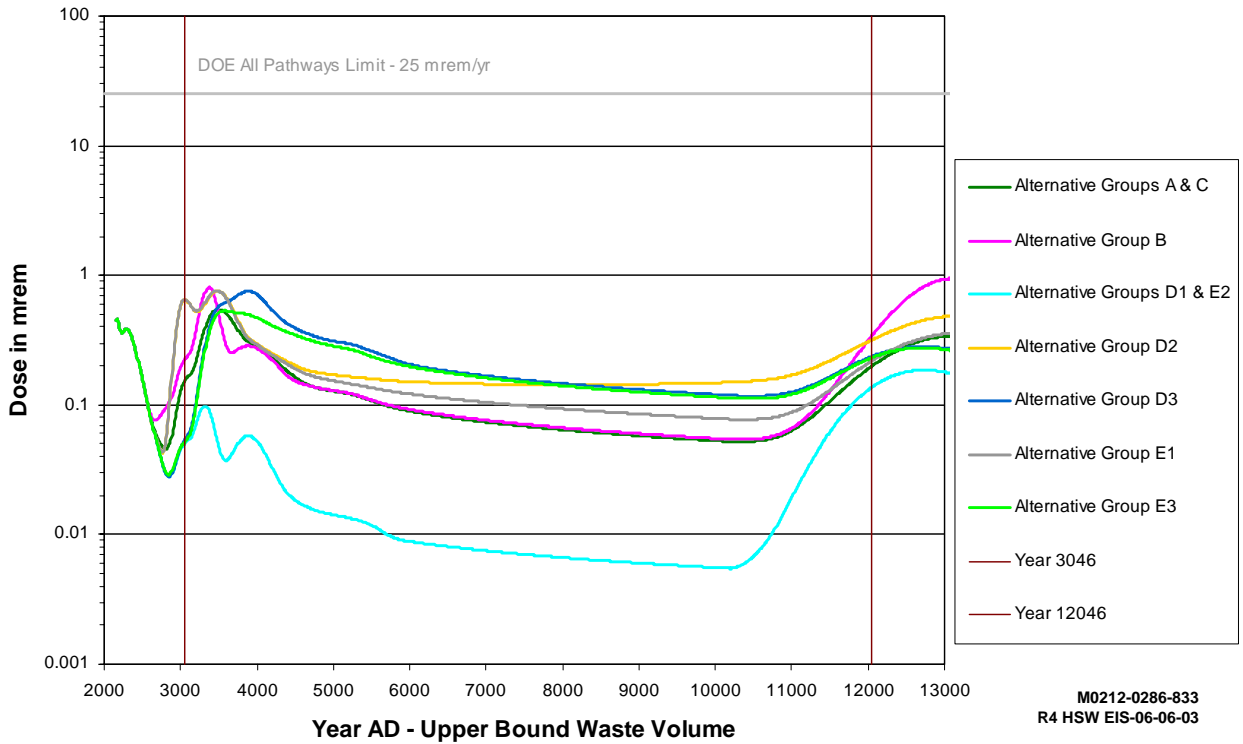
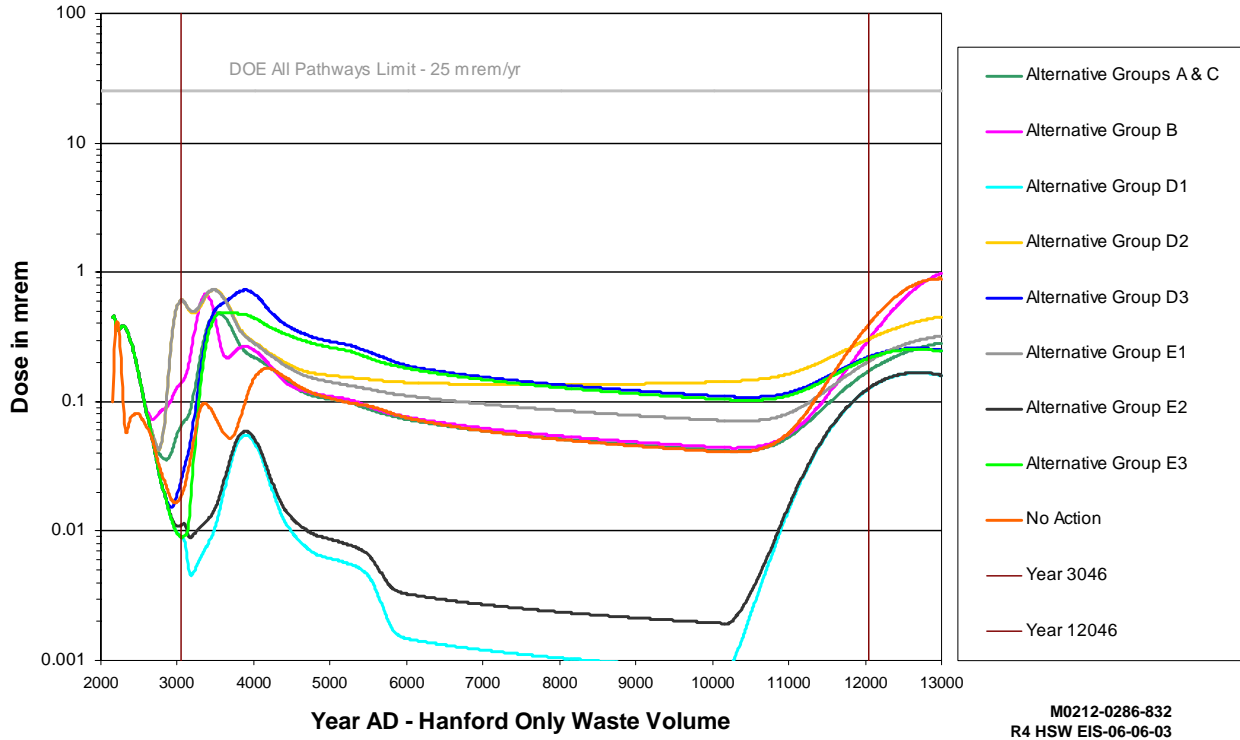
M0212-0286-830  
R4 HSW EIS-06-06-03



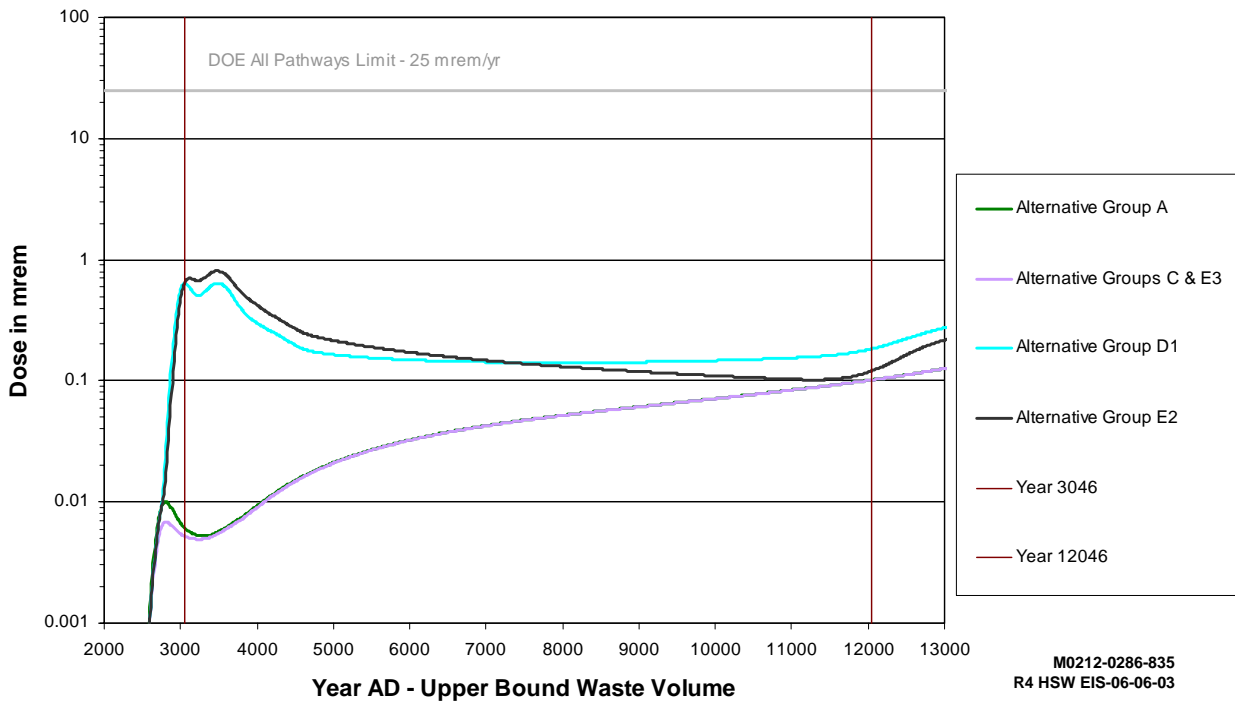
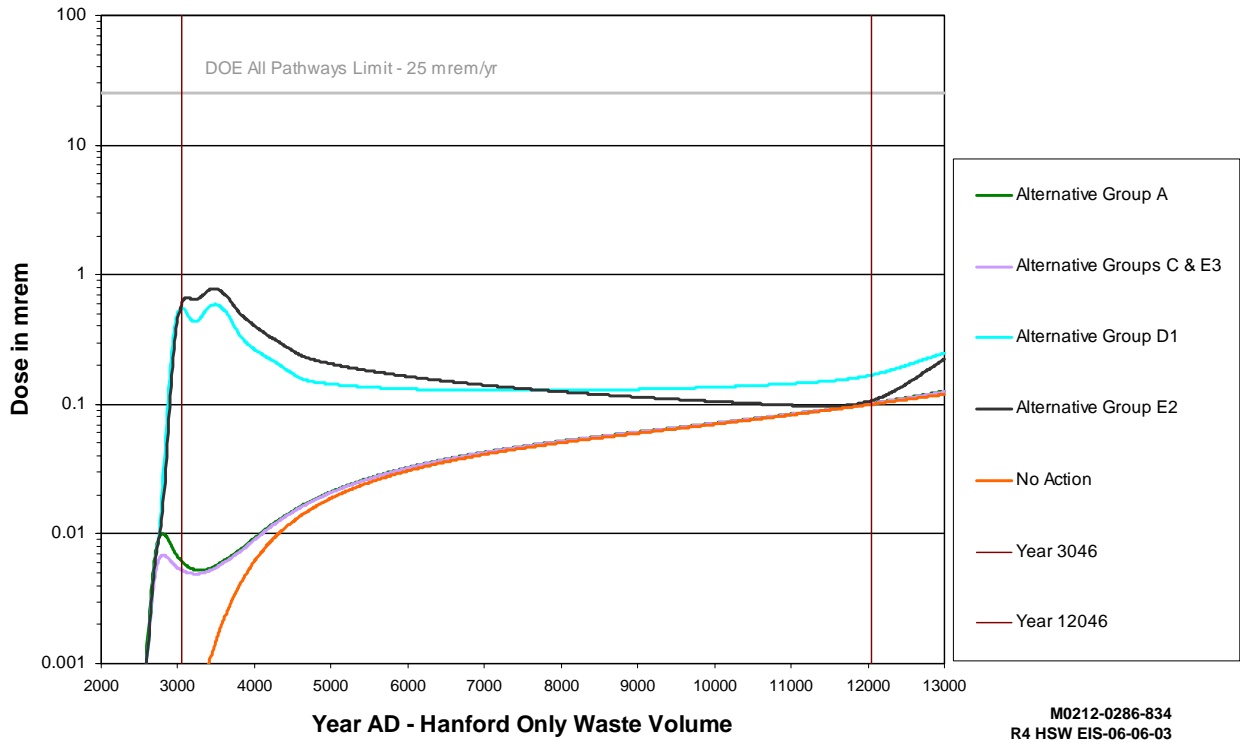
M0212-0286-831  
R4 HSW EIS-06-06-03

**Figure 3.10.** Annual Dose to a Hypothetical Resident Gardener at Various Times over 10,000 Years Using Water from a Well 1 km Downgradient from ERDF

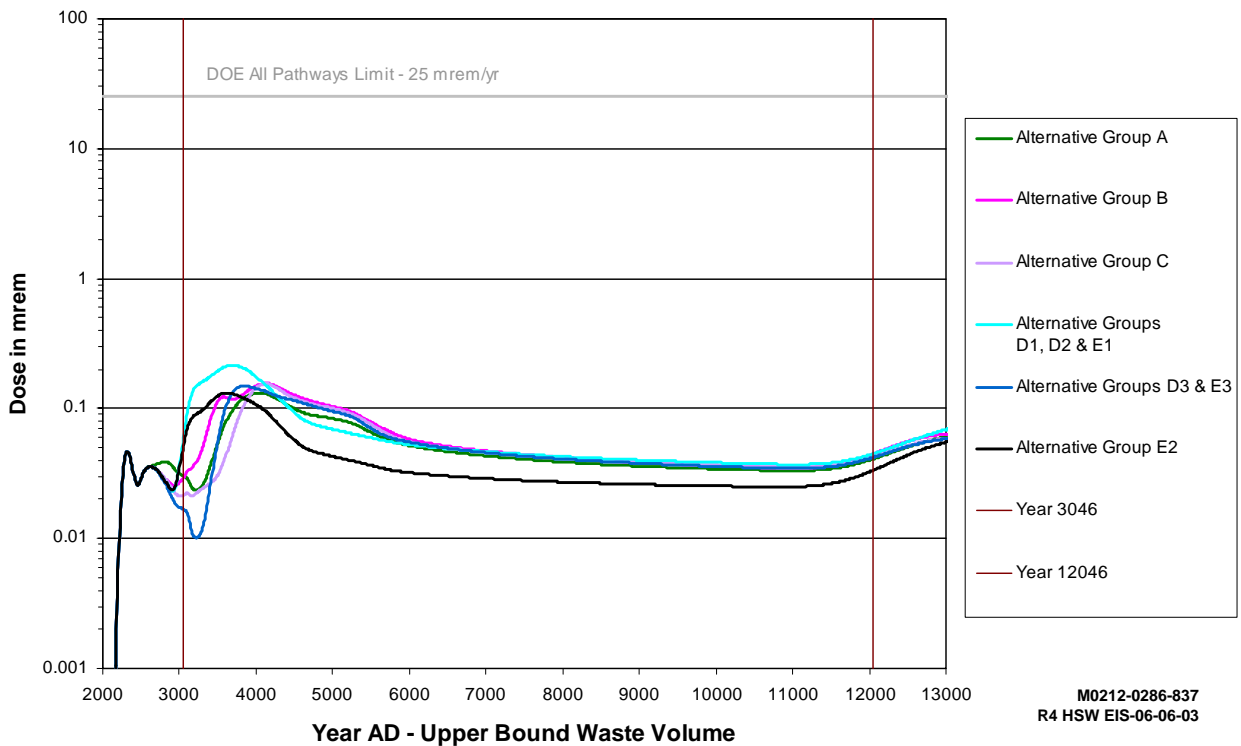
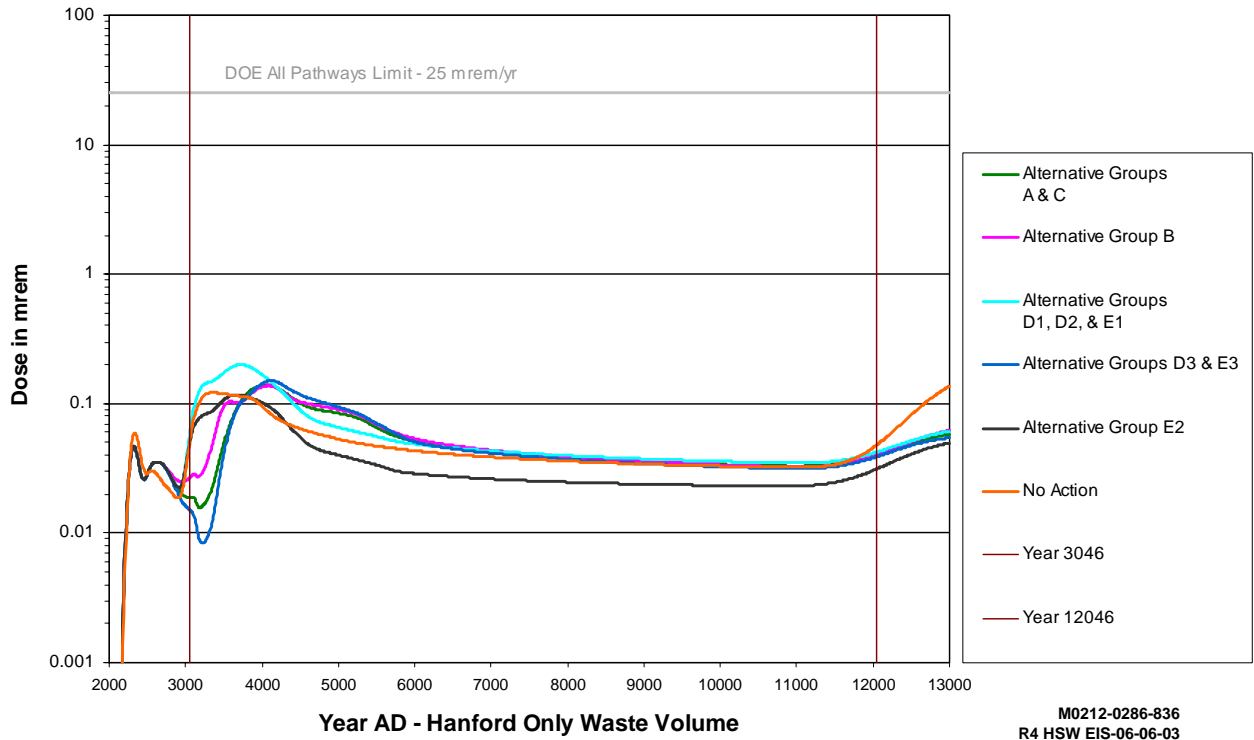




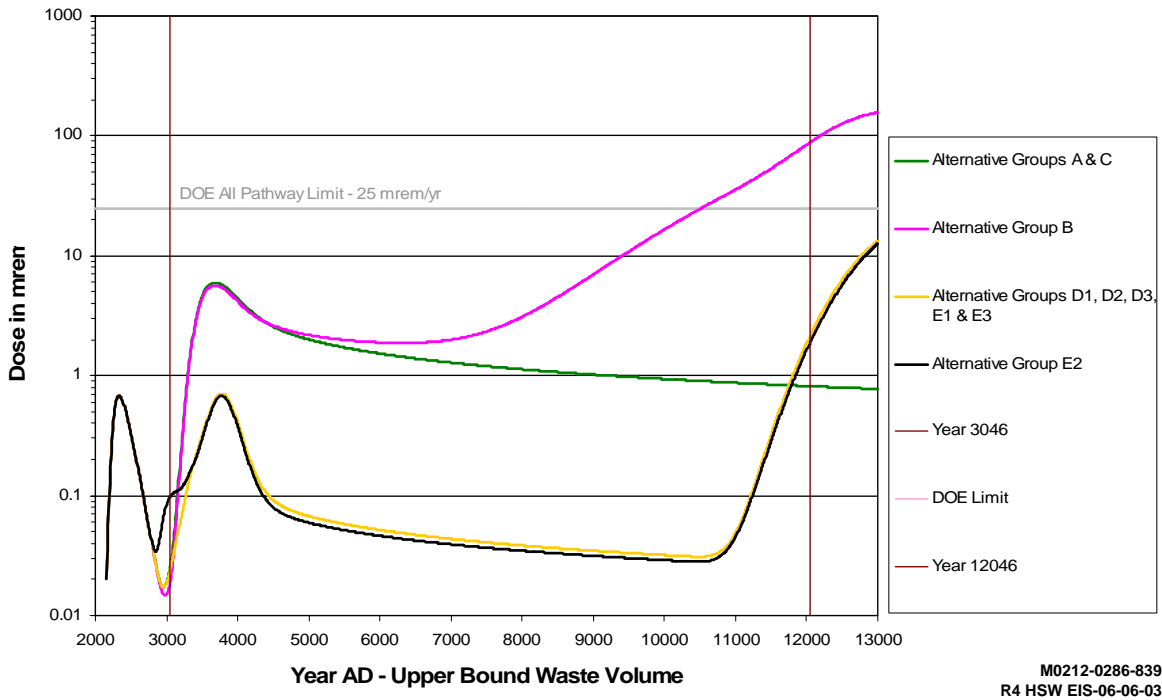
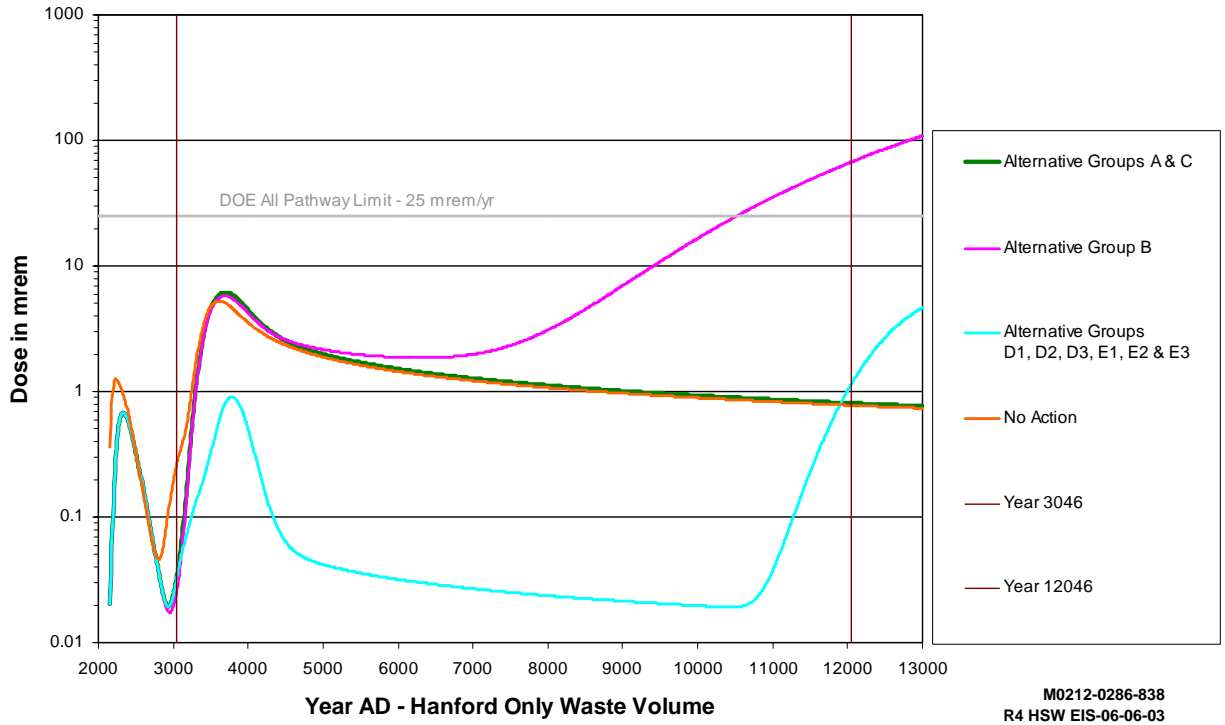
**Figure 3.11.** Annual Dose to a Hypothetical Resident Gardener at Various Times over 10,000 Years Using Water from a Well 1 km Downgradient Northwest from the 200 East Area



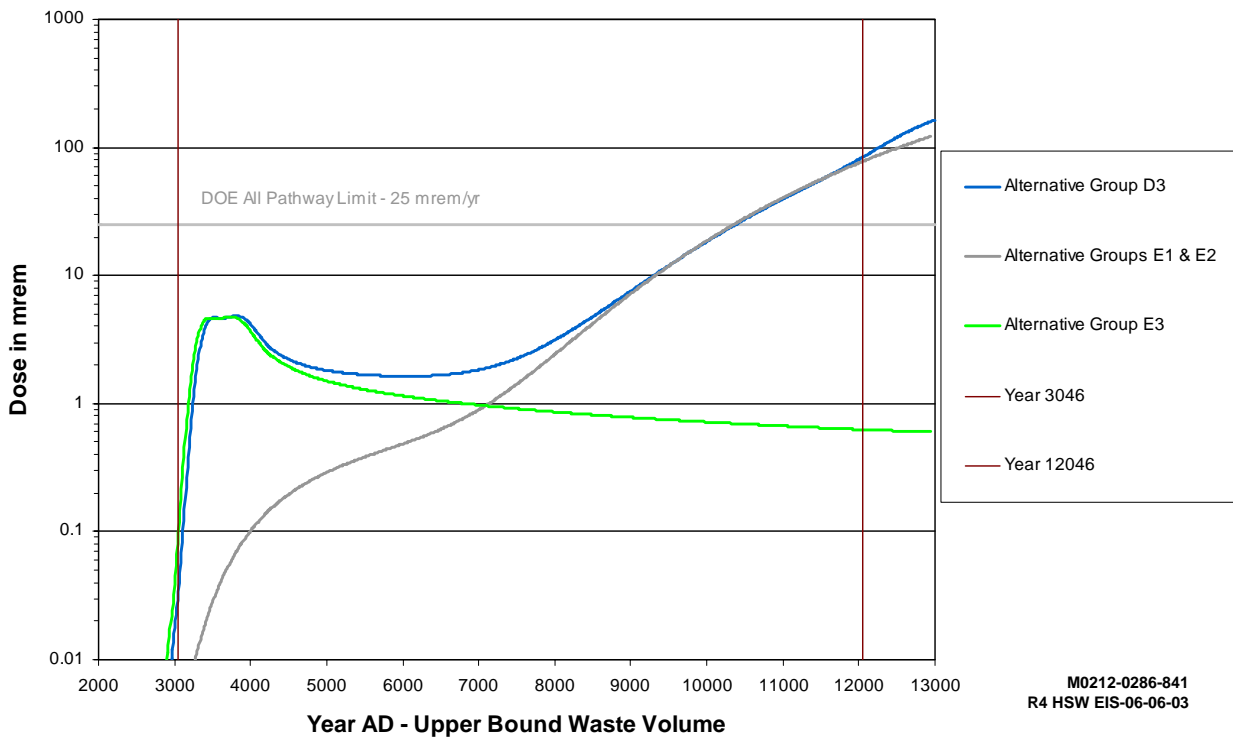
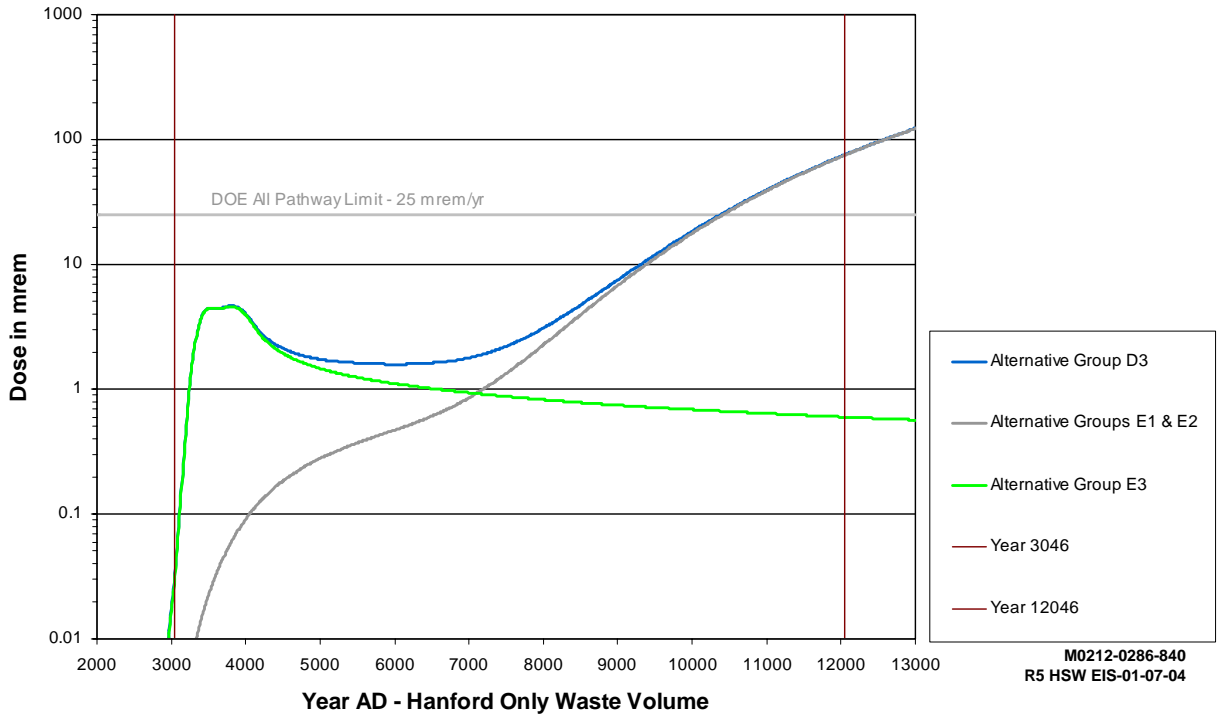
**Figure 3.12.** Annual Dose to a Hypothetical Resident Gardener at Various Times over 10,000 Years Using Water from a Well 1 km Downgradient Southeast from the 200 East Area



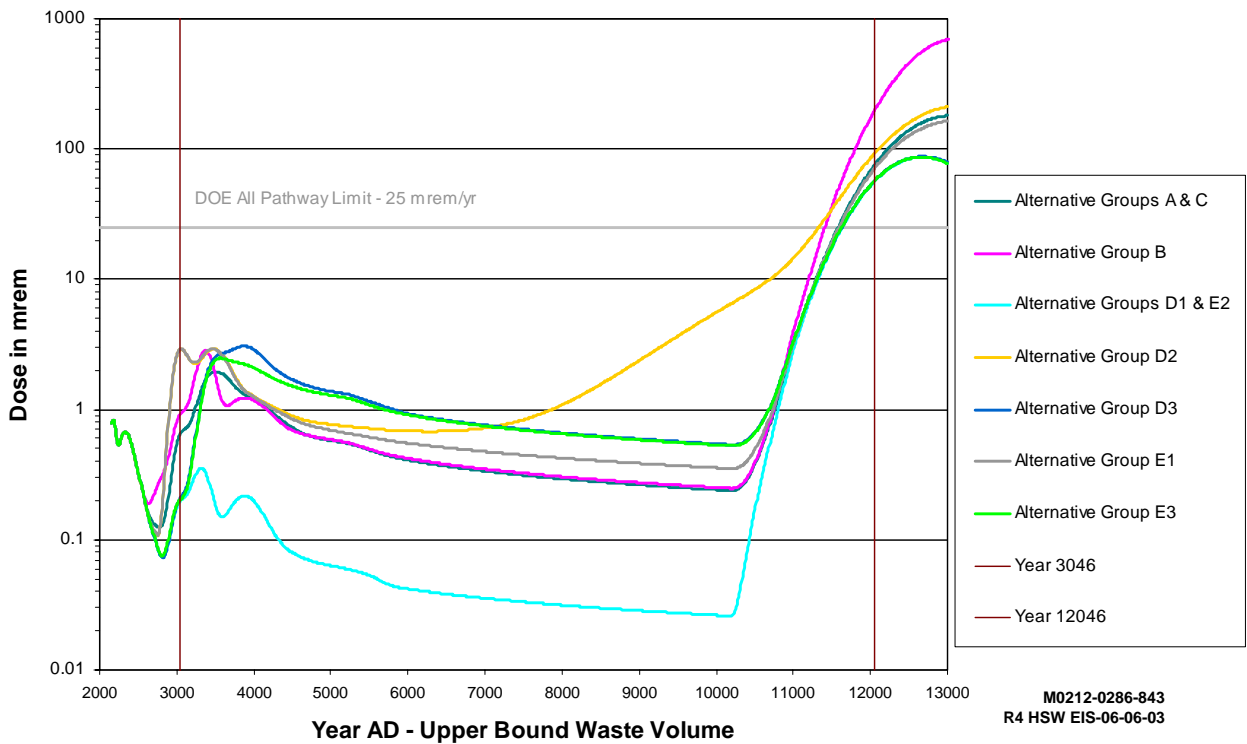
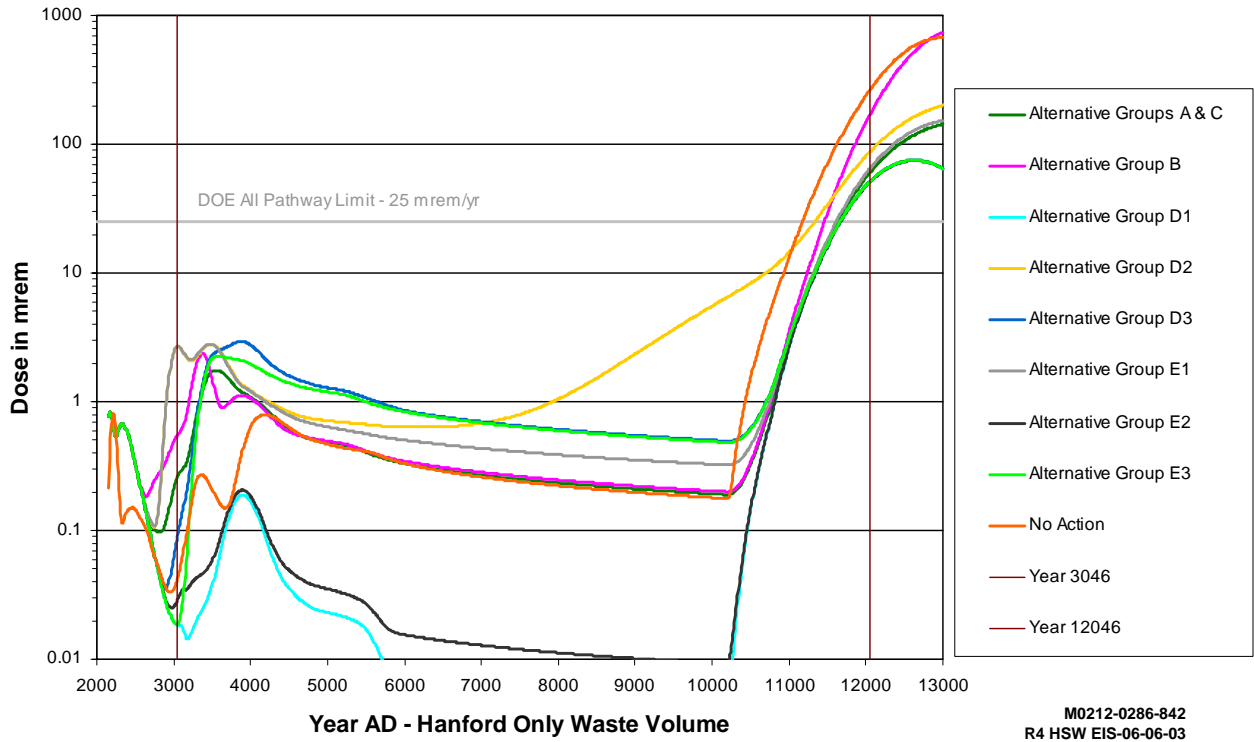
**Figure 3.13.** Annual Dose to a Hypothetical Resident Gardener at Various Times over 10,000 Years Using Water from a Well Adjacent to the Columbia River



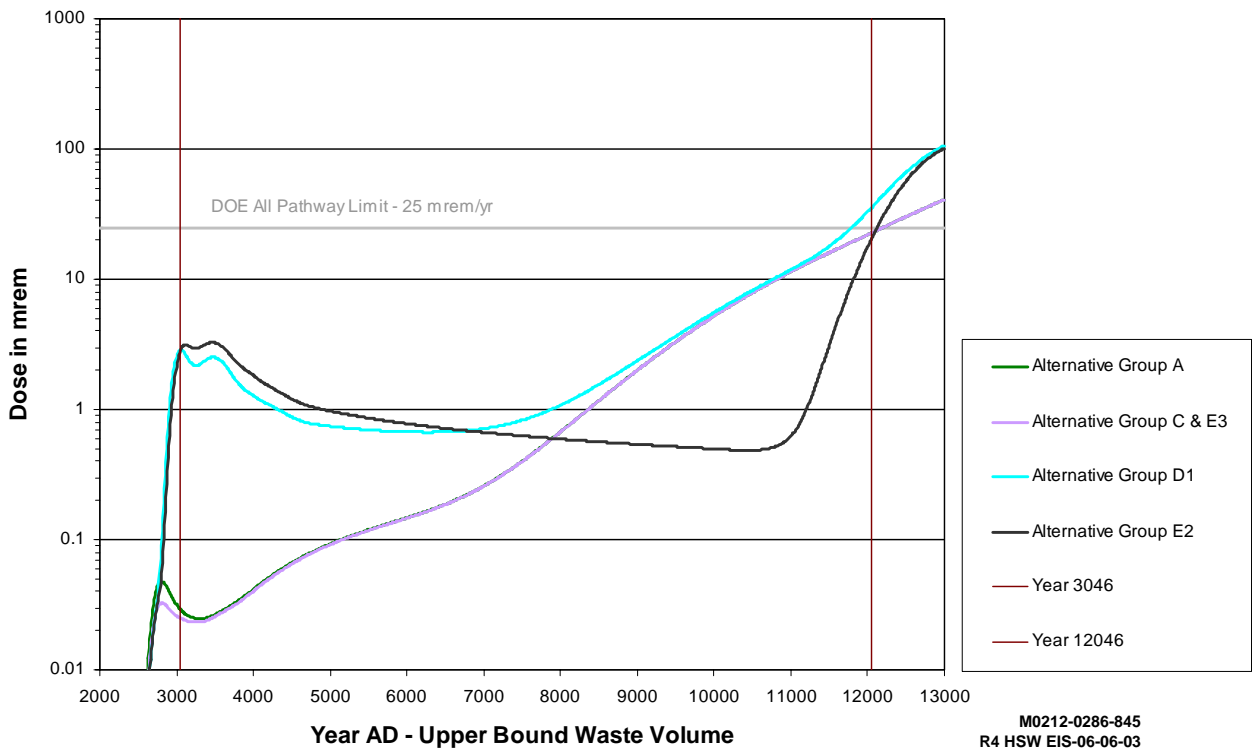
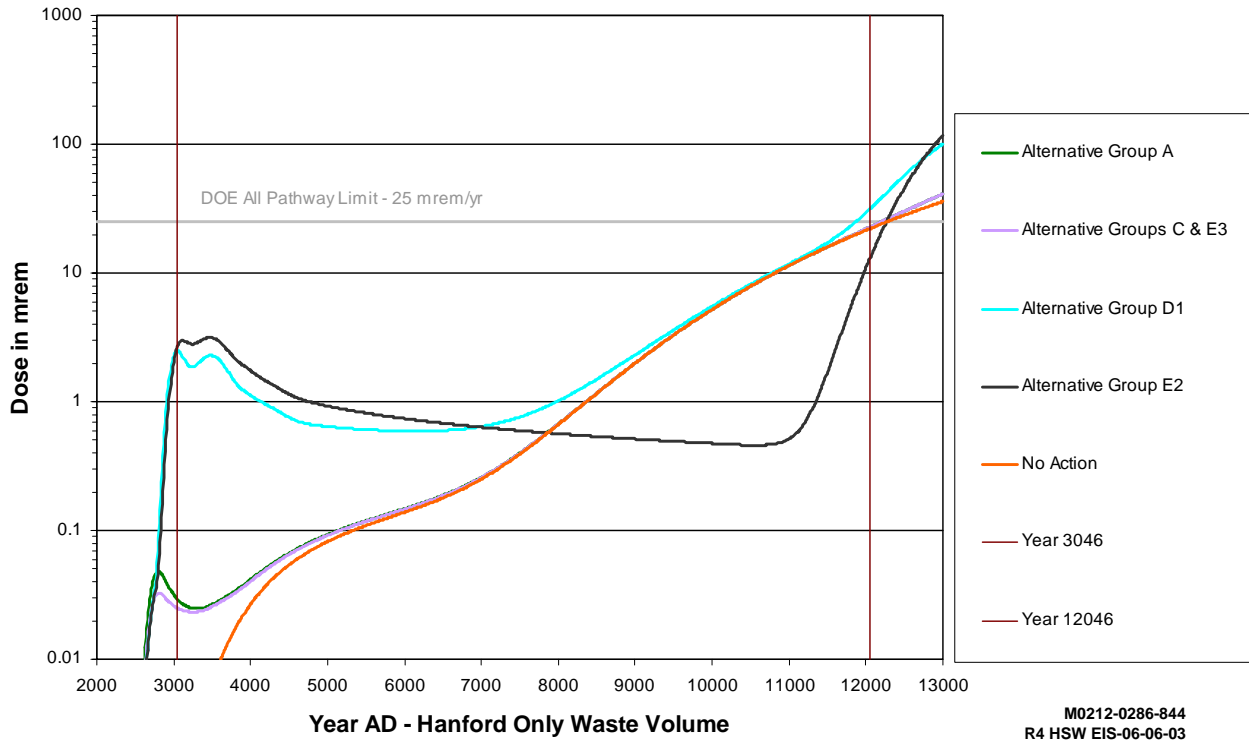
**Figure 3.14.** Annual Dose to a Hypothetical Resident Gardener with Sauna/Sweat Lodge at Various Times over 10,000 Years Using Water from a Well 1 km Downgradient from the 200 West Area



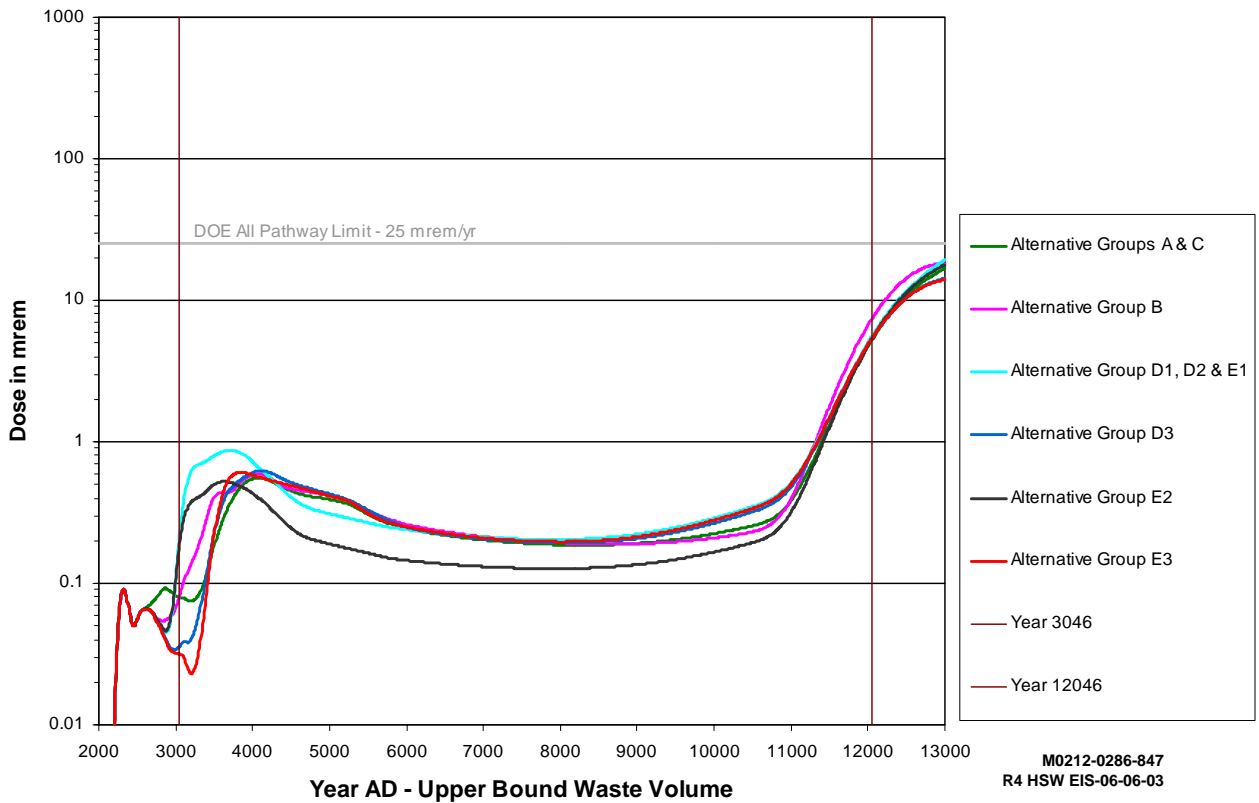
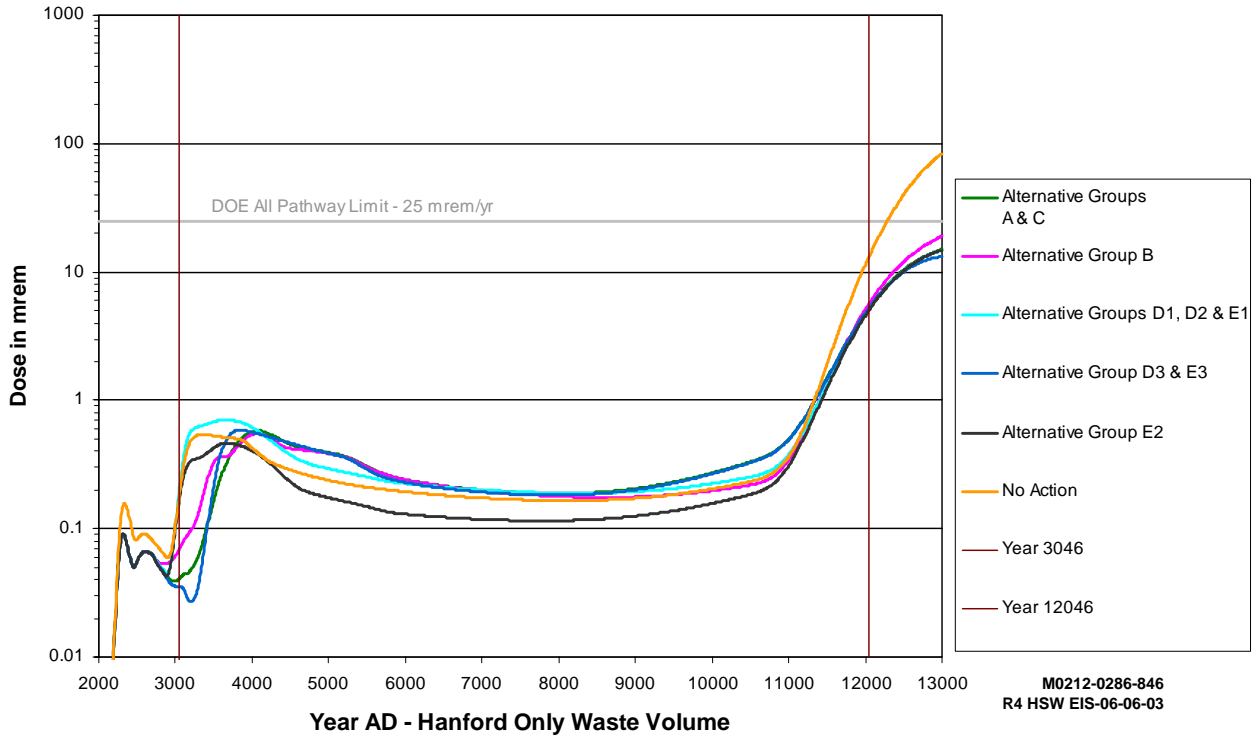
**Figure 3.15.** Annual Dose to a Hypothetical Resident Gardener with Sauna/Sweat Lodge at Various Times over 10,000 Years Using Water from a Well 1 km Downgradient from ERDF



**Figure 3.16.** Annual Dose to a Hypothetical Resident Gardener with Sauna/Sweat Lodge at Various Times over 10,000 Years Using Water from a Well 1 km Downgradient Northwest from the 200 East Area



**Figure 3.17.** Annual Dose to a Hypothetical Resident Gardener with Sauna/Sweat Lodge at Various Times over 10,000 Years Using Water from a Well 1 km Downgradient Southeast from the 200 East Area



**Figure 3.18.** Annual Dose to a Hypothetical Resident Gardener with Sauna/Sweat Lodge at Various Times over 10,000 Years Using Water from a Well Adjacent to the Columbia River



### 3.5 Areas of Uncertainty, Incomplete, or Unavailable Information

This section discusses uncertainties associated with alternatives evaluated in the HSW EIS, and takes into account areas where information is either incomplete or unavailable. Because an EIS is by nature a document prepared during the planning stages for a proposed action, information needed to evaluate environmental impacts of the activities in detail may not always be available. In some cases, there are uncertainties that cannot be resolved by collection or development of additional information, such as the uncertainties associated with projected environmental impacts at very long times in the future, or those associated with inherent variability in human and ecological systems. The approach used to account for these uncertainties would vary with the nature of the impact being evaluated and the methods used for the assessment. The individual analyses of environmental impact areas in Section 5 provide additional detail regarding uncertainties unique to each evaluation where applicable.

The National Council on Radiation Protection and Measurements (NCRP 1996) provides guidelines for performing uncertainty analyses in dose and risk assessments, including guidance for determining when uncertainty analysis is warranted, methods for performing uncertainty analyses, and elicitation of expert judgment for use in uncertainty analysis. A detailed quantitative uncertainty analysis may not be necessary or possible when

1. Conservatively biased screening calculations indicate that the risk from possible exposure is clearly below regulatory or risk levels of concern.
2. The cost of an action required to reduce exposure is low.
3. Data for characterizing the nature and extent of contamination at a site are inadequate to permit even a bounding estimate (an upper and lower estimate of the expected value).

Conditions that may justify preparation of a quantitative uncertainty analysis include

1. An erroneous result in the dose or risk assessment may lead to large or unacceptable consequences.
2. A realistic rather than a conservative estimate is needed.
3. A need to set priorities for the assessment components for which additional information will likely lead to improved confidence in the estimate of dose and risk.

The HSW EIS analyses rely on various modeling approaches to predict consequences of actions that DOE may undertake in the future. In some cases, the model may be a simple scaling of available data for similar activities to the specific scope of activities expected for each of the EIS alternatives. For example, average historical radiation doses to waste management workers could be used to predict collective doses for the number of workers required to carry out the proposed actions. In other cases, the models may be extremely complex and require inputs of data and assumptions that are subject to much more uncertainty. In this EIS, estimation of long-term performance for waste disposal facilities involves such a model, which requires extensive inputs of information related to quantities of potentially hazardous constituents in the facility, release of those constituents from the waste, transport of the materials through the vadose zone and groundwater, and ultimate use of groundwater or the Columbia River for various activities such as agriculture or recreation. In such models, historical data for the necessary input information does not

always exist over the time periods of interest, or it may be highly variable because of inherent unpredictability in the behavior of geological, biological, or ecological systems.

Two approaches are typically used to address uncertainty in conducting analyses of prospective impacts and risk. The simplest involves using conservative input data and assumptions for the parameters of interest, such that actual consequences are unlikely to exceed the estimated consequences. This approach is often used in demonstrating compliance with regulatory standards, for example, to ensure comparability among assessments for different sites and facilities, and for consistency with methods used to develop the standards themselves. It is also the approach typically used in this EIS to assess consequences where detailed information about facility design and activities are evolving or awaiting future decisions. In most cases, it provides sufficient information to ensure that proposed actions would meet applicable regulatory standards and to compare the relative impacts of various alternatives.

**Conservative Assumptions in the HSW EIS**  
Within this EIS, the term “conservative” refers to assumptions used in the various environmental consequence analyses that tend to bound, maximize, or overestimate the potential impacts. Such assumptions are typically used when specific information regarding an activity is not available, or is at a conceptual stage of development. These assumptions are used to ensure that the analyses do not underestimate the effects of the proposed actions on human health and the environment.

A second possible approach is to conduct an uncertainty analysis that produces a statistical distribution of potential consequences. The distribution of results provides a measure of central tendency for the consequence of interest (mean, median, or mode), as well as a measure of the likelihood of consequences at the extreme ends of the distribution (95% confidence limits, for example). This approach involves developing distributions of values for each of the key input parameters in a model and performing a series of calculations, using randomly selected values from the input distributions, to produce the statistical distribution of potential consequences. However, this type of analysis requires extensive effort and may be limited by availability of information with which to develop the required input parameter distributions. It is typically not necessary for the types of analyses included in this EIS, although it has been applied to the cumulative long-term impacts on groundwater (see Appendix L). The following sections provide a general discussion of uncertainties associated with the HSW EIS analyses and the manner in which they are addressed. Additional information is provided in the sections that present the analysis results and their associated appendixes.

### 3.5.1 Waste Volumes

The volume of wastes that could ultimately be managed at Hanford represents one of the larger uncertainties associated with the analyses in this EIS. Many of the impact assessments depend on the waste volume that ultimately requires treatment or disposal onsite. Forecasts of future waste volumes from Hanford generators have been compiled for a number of years, and have been shown to be reasonably accurate, if somewhat conservative overall (see Appendix B). Potential waste receipts from offsite generators are associated with uncertainties due to cost, schedule, and other factors. The performance assessment process for disposal facilities may also limit incoming waste quantities in order to ensure compliance with applicable requirements. The HSW EIS accounts for this uncertainty by

evaluating a range of waste volumes as described in Section 3.3. Those waste volumes represent estimates of the minimum and maximum waste quantities reasonably expected to be received at Hanford during active waste management operations. The basis for the waste volumes is described in Appendixes B and C.

### **3.5.2 Waste Inventories of Radioactive Materials**

The quantities of radioactive components in waste also contribute to environmental impacts, particularly those associated with air emissions and long-term performance of disposal facilities. The basis for waste inventories varies with the type of waste and its source, and may include information such as process knowledge or direct assay. In general, inventories for wastes received in recent years are expected to be associated with less uncertainty than those disposed of in the early 1970s. Wastes received in later years are more fully characterized because of improved analytical capabilities and added requirements for record keeping. The HSW EIS analyses account for those uncertainties by making conservative assumptions (that is, assumptions that would tend to maximize the impacts) regarding waste inventories based on process knowledge, assays of previously received waste, or other available information from waste generators. For example, the inventory of iodine-129 in past and potential future waste receipts has been estimated using the total production at Hanford, sampling of releases to the atmosphere from fuel processing facilities, and analytical information on tank waste and other waste streams. That inventory is expected to overestimate iodine-129 actually disposed of at Hanford for reasons described in Appendix L.

Wastes and residual soil contamination remaining at Hanford over the long term that are not specifically evaluated as part of the HSW EIS alternatives may also contribute to contamination of groundwater and the Columbia River. Impacts from some of those wastes were evaluated previously as part of NEPA or CERCLA reviews. For example, the HDW EIS (DOE 1987) and Bryce et al. (2002), suggest that the risks associated with radionuclides in older solid waste sites would be small, consistent with the cumulative impacts analysis in this EIS (see Section 5.14 and Appendix L).

DOE plans to characterize solid waste disposal facilities under RCRA past practice or CERCLA processes to determine whether remedial action would be required before the facilities are closed. Those evaluations for 200 Area facilities are scheduled to be completed in 2008. Therefore, the long-term risks from these wastes would either be determined to be acceptable, or the waste site would be remediated.

### **3.5.3 Waste Inventories of Non-Radioactive Hazardous Materials**

Hazardous chemicals in MLLW have been characterized and documented since the implementation of RCRA at DOE facilities beginning in 1987. MLLW currently in storage, and MLLW that may be received in the future, would be treated to applicable state and federal standards for land disposal. Therefore, disposal of that waste is not expected to present a hazard over the long term because the hazardous components would either be destroyed or stabilized by the treatment. Inventories of hazardous materials in stored and forecast waste are either very small, or consist of materials with low mobility (see Appendixes F and G).

Inventories of hazardous chemicals in wastes were not generally maintained by industries in the United States prior to the implementation of RCRA. Consistent with these general practices, inventories of hazardous chemicals in radioactive waste were not required to be determined or documented before the application of RCRA to radioactive mixed waste at DOE facilities. Therefore, uncertainty regarding the content of hazardous materials in wastes disposed of before that time is generally higher than for radionuclides. Preliminary estimates of chemical inventories in pre-1988 waste have been developed for analysis in the HSW EIS, and a summary of their potential impacts on groundwater is presented in Section 5.3 and Appendix G. A list of the types of hazardous constituents in solid waste disposed of between 1968 and 1988 indicates the presence of some RCRA- or state-designated hazardous inorganic chemicals, acids, oils, solvents, and metals such as lead (DOE-RL 1989; FH 2004). Lead, which comprises the bulk of these materials, was in a solid non-dispersible form that is not highly mobile in groundwater. In cases where limited quantities of liquids were present in wastes received for storage or disposal, they were packaged in multiple containers with sufficient absorbent to contain the liquids (DOE 1985). Practices used to stabilize and contain radionuclides in the waste would also aid in limiting migration of non-radioactive hazardous constituents. Sampling of soil and groundwater upgradient and downgradient from active solid waste disposal facilities has not provided evidence that these facilities contributed to existing groundwater contamination (Hartman et al. 2002). As with the older radioactive waste disposal sites, disposal facilities containing pre-1988 waste would be evaluated using the RCRA past practice or CERCLA processes to determine whether remedial action is required before the facilities are closed. Therefore, the long-term risks from these wastes would either be determined to be acceptable, or the waste site would be remediated.

Most hazardous materials historically used in large quantities at Hanford were organic liquids or solutions containing inorganic compounds and metals such as chromium. Bulk liquid wastes were stored in underground tanks, or disposed of directly to the ground via ponds, trenches, cribs and ditches. The practice of discharging untreated liquid waste to the ground was reduced in the 1980s and discontinued in 1995. Some contaminants have been detected in groundwater as a result of those past liquid waste disposal practices. A previous evaluation of waste disposal sites confirmed that groundwater contamination by hazardous chemicals was primarily a result of past liquid discharges rather than solid waste disposals (DOE 1996).

DOE has an ongoing program to characterize and remediate soil and groundwater contaminated by past liquid discharges (Hartman et al. 2002). For example, some LLBGs in the 200 West Area were sampled recently as part of an ongoing CERCLA investigation to characterize and remediate past carbon tetrachloride discharges in the vicinity of the Plutonium Finishing Plant. Sampling detected the presence of carbon tetrachloride vapor in soil at the bottom of some disposal trenches about 4.6–6.1 m (15–20 ft) below ground. The source of the vapor could not be determined from the initial sampling, but was estimated to be either waste in the disposal trench, or lateral migration of vapor from former liquid discharge sites in the vicinity. The sampling risers were capped except during sample collection, and measured vapor concentrations in air at the ground surface were well within workplace exposure standards. Because of those results, and because the vapor is approximately five times the density of air, there was no evidence that potentially hazardous releases to the atmosphere had occurred. However, additional soil sampling has been planned to investigate the source of the vapor and to determine whether there may have been liquid carbon tetrachloride releases to soil beneath the trenches. Depending on those future

findings, remedial actions would be carried out during retrieval of stored transuranic waste from the trenches or at closure of the LLBGs. In all cases, the potential for hazardous material releases to the atmosphere and exposures to workers would be evaluated in advance. Workers would use protective clothing and equipment as required to minimize exposure during sampling or retrieval operations. Other measures, such as extraction of vapor from the soil or use of appropriate containment, would be implemented to ensure that exposures to workers in nearby facilities and offsite members of the public would be within applicable standards.

Hanford's waste tanks also contain a complex mixture of radionuclides and chemicals, which adds a degree of uncertainty to the analyses associated with ILAW disposal. Historical data, such as chemical purchase invoices, records of waste transfers, and process knowledge, have been used to estimate total inventories of materials in the tank waste collectively. There is an ongoing waste characterization program to better determine the contents of each individual tank through sampling and analysis to support safety evaluations and remedial action decisions. Collection of that information continues, but is not yet complete. The lack of detailed characterization information on a tank-by-tank basis adds a level of uncertainty to certain aspects of the tank waste treatment project. However, that information is less critical to determining the long-term impacts of disposal, which are based on the total ILAW inventory. Treatment processes that would affect the composition and form of the final product are still under investigation as well. Some of the processes under consideration have not been applied to this type of waste, or have not been used on the scale necessary for the project, and some uncertainty will remain in these areas until the processes are more fully developed and tested. To account for these uncertainties, the assumptions in this HSW EIS are based on waste characterization and processing data that are intended to provide a conservative, or bounding, analysis of impacts for the alternatives under consideration. Previous evaluations of tank waste management alternatives indicated the long-term health risks from both radionuclides and chemicals in the waste were small and that concentrations of hazardous constituents in both groundwater and the Columbia River would meet federal drinking water standards (DOE 1987; DOE and Ecology 1996). Further evaluation of those risks is anticipated in the *Environmental Impact Statement for Retrieval, Treatment, and Disposal of Tank Waste and Closure of Single-Shell Tanks at the Hanford Site* (68 FR 1052).

#### **3.5.4 Release, Fate, and Transport of Radioactive and Hazardous Materials**

Estimating transport of hazardous materials or radionuclides through various environmental pathways to human or ecological receptors is a complex process, often requiring extensive input data. In order to predict the potential for future impacts, it is typically necessary to use computer models to simulate their transport and receptor exposure rates. Computer modeling may also be used to estimate the impacts from past releases where the quantity of released material is too small to measure in the field, or where contaminants arrive at the receptor location at very long times after the release occurs. The amount of data required for a particular simulation depends on the transport medium and exposure pathways of interest. The information needed to model transport through the environment may be relatively straightforward, such as measurements of wind direction and velocity, or highly complex, such as groundwater flow rates and directions. Likewise, exposure of receptors can depend on the behaviors of individuals or populations, such as food consumption rates.

With respect to long-term performance of disposal facilities, the transport of contaminants depends on performance of the waste form, factors affecting infiltration of water through the waste, and flow rates of groundwater, all of which are subject to substantial uncertainty over the long term. Contaminant release rates depend on treatment processes and the resulting physical and chemical characteristics of the waste form. For example, future decisions regarding the tank waste treatment process may affect the composition and long-term performance of the ILAW product, and some uncertainty will remain in these areas until the processes are more fully developed and tested. Performance of different ILAW waste forms is discussed briefly in Appendix G. Performance of the engineered disposal system, such as the use of greater confinement (HICs or trench grouting), trench liners, or infiltration barriers over the disposal facility is also difficult to predict over the very long time periods used for the analyses in performance assessments and in this EIS. Sensitivity analyses for barrier performance in the preferred alternative are presented in Appendix G. Other factors such as the geochemical environment, climate, and natural recharge rates in the future add to the uncertainty in predicting contaminant transport. In general, interactions among waste components that could change the geochemistry in the immediate vicinity of the disposal facility, such as the possible presence of organic chemicals in some previously disposed waste, are not expected to affect contaminant mobility over the long term. Such interactions would require relatively high concentrations of contaminants or large volumes of liquids to substantially influence contaminant mobility over the entire transport path. The solid wastes considered in this EIS would not contain large enough quantities of liquid organic chemicals or other potentially mobilizing agents to affect transport by this mechanism (See Appendix G).

After contaminants reach the accessible environment, potential impacts are controlled by the mechanisms that result in exposure to individuals or populations. A recent study of long-term transport of contaminants in groundwater indicated that, for estimates of human health effects, variability with regard to individual receptor behavior and exposure affects uncertainty in the result more than variability in inventory, release, or environmental transport of the contaminant. For example, uncertainties in estimates of near-term (present-day) risk to a hypothetical onsite resident farmer using tritium-contaminated groundwater downgradient from the 200 Area were dominated by uncertainties in the ingestion dose factor and by ingestion rates of contaminated food. Over the longer term (1,000 years), technetium-99 accounted for the largest share of risk to the onsite resident farmer from groundwater. At that time, parameters for transfer of technetium-99 to milk and vegetation, the technetium-99 ingestion dose factor, and technetium-99 ingestion rates for vegetables dominated the uncertainty. Estimates of release and transport accounted for a relatively small fraction (less than 15 percent) of the overall uncertainty in risk at either time (Bryce et al. 2002).

To account for these uncertainties, the assumptions in this EIS are based on waste characterization and processing data that are intended to provide a conservative, or bounding, analysis of impacts for the alternatives under consideration. Engineered systems are assumed to be effective for a reasonable but limited time compared with the period of analysis. Uncertainties associated with exposure parameters are typically addressed by using conservative assumptions in the model simulations, that is, assumptions that tend to maximize the exposure of individuals or populations to contaminants. An example is the use of atmospheric dispersion conditions that maximize the downwind concentrations of hazardous materials in accident simulations, as in the analyses reported in Section 5.11. In other cases, each parameter input to a simulation can be assigned a distribution of values, and multiple simulations can be run using randomly

selected values for each parameter to obtain a distribution of outcomes associated with various probabilities. That approach was used to some extent for the cumulative groundwater impacts analysis described in Section 5.14 and Appendix L.

### **3.5.5 Human and Ecological Risk Associated with Exposure to Radioactive and Hazardous Materials**

Human and ecological risk estimates are subject to many of the same uncertainties associated with fate and transport as described in the previous section. An added uncertainty is the inherent variability in biological and ecological systems, such as the genetic variation in populations that may predispose a particular individual to adverse health effects following exposure to a potentially hazardous material. Data on relative risks from hazardous material exposure are typically more difficult to obtain because of the ethical constraints on experimentation with human subjects. Extrapolating risk from animal studies to humans, or extrapolations of ecological impacts between different animal species, introduces additional uncertainty into the consequence estimates. As with the environmental transport calculations the approach used in the HSW EIS was to assign conservative values to most of the input parameters used in modeling risk from hazardous material exposures. For example, the estimates of potential cancer risk from exposure to radiation at very low doses, such as those from most environmental exposures, are based on data obtained at higher exposure rates and by different exposure pathways. The effect is assumed to be proportional to the dose received, although in the case of radiation, there is no experimental or epidemiological evidence that such effects occur at very low doses. The estimates of cancer incidence or fatality from very low radiation doses are therefore conservatively high, and encompass a range of possible risks that includes zero risk. Estimates of cancer risk in populations represent averages that account for the range in sensitivities of various members of the population, including children as well as adults.

In the HSW EIS analysis, exposure and risk parameters were generally set to reference values that have been widely adopted by regulatory agencies to establish environmental standards and to demonstrate compliance with those standards (such as the assumed consumption rate of 2 L/day used by EPA as the basis for setting standards for chemicals in public drinking water supplies). These reference parameter values are typically established to maximize the hypothetical risk that could occur to an individual who might be exposed via various pathways. This approach provides reasonable assurance that potential exposure to an actual individual would be unlikely to result in substantially greater risk. In any case, the comparison of impacts among the HSW EIS alternatives, and subsequent decisions based on the analyses, would not be affected by such assumptions because they are applied uniformly across all alternative groups.

### **3.5.6 Technical Maturity of Alternative Treatment Processes**

Treatment technologies for most types of MLLW are specified by regulation. Where more than one technology might apply to a particular waste stream, a reference treatment technology was assumed for purposes of analysis. The consequences of waste treatment were typically estimated using conservative but realistic assumptions appropriate for the reference technology. For example, thermal treatment processes would be expected to result in greater emissions to the atmosphere than non-thermal technologies such as macroencapsulation. One uncertainty associated with MLLW treatment is the currently limited

availability of thermal treatment processes for waste containing hazardous organic components. For purposes of analysis, this EIS assumed such treatment would be available at offsite commercial facilities within a reasonable time. However, an additional alternative was evaluated to consider the use of non-thermal options for those wastes in the event such treatment is not available.

With respect to ILAW, the reference treatment was assumed to be vitrification or another technology that produces a waste form having equivalent long-term performance. Other treatment technologies are currently under consideration for the low activity waste stream. Further evaluation of low activity waste treatment alternatives is anticipated in the *Environmental Impact Statement for Retrieval, Treatment, and Disposal of Tank Waste and Closure of Single-Shell Tanks at the Hanford Site* (68 FR 1052). Uncertainties associated with long-term performance of ILAW are addressed in this EIS by considering a range of performance characteristics for this waste stream (see Appendix G).

### **3.5.7 Timing of Activities Evaluated in the Alternative Groups**

Under all HSW EIS alternative groups, there are uncertainties related to the timing of their implementation. Timing uncertainties include:

- the technical maturity of waste treatment technologies and the amount of development necessary before design and construction of facilities could proceed
- the possibility that regulatory requirements could change, which could introduce delays by affecting the design and cost of selected alternatives
- the time required to obtain necessary permits and approvals for various treatment, storage and disposal actions
- the timely appropriation of funds by Congress to enable DOE to implement decisions resulting from this EIS
- the effect of proposals for accelerated cleanup at Hanford (DOE-RL 2002) and at other DOE facilities, which could potentially influence the timing and quantities of waste receipts.

As discussed previously, these uncertainties are typically addressed in this EIS by adopting conservative assumptions in analyses (that is, assumptions that would tend to maximize the estimated environmental impacts). The timing of activities evaluated in the EIS may differ from assumptions used in the analyses; however, the nature and extent of those actions are expected to be similar whenever they may occur.



### 3.6 Costs of Alternatives

Consolidated cost estimates were prepared for the continued operation of existing facilities, the modification of existing facilities, construction of new facilities, and operation of the new or modified facilities (FH 2004; Aromi and Freeburg 2002). The costs were calculated using a constant 2002 dollars. Some operations, such as capping the LLBGs and treatment of leachate from mixed waste trenches, would continue beyond 2046. These costs have been included as a separate category. The cost of each major facility for each alternative group is shown in Table 3.21. The increased costs for the operation of the LLBGs with the increased volume of waste can be seen. Because the additional MLLW in the Upper Bound waste volume do not need treatment, the costs for treatment facilities do not change. In the No Action Alternative Group, the increased needs for storage of MLLW and the limited volume of waste disposed of are reflected in the relative costs of the CWC and the MLLW trenches. The increased costs for the baseline operation of the T Plant Complex for the No Action Alternative Group compared with Alternative Groups A, B, and C result from the continuing need to store the K Basin sludge in the No Action Alternative. The combination of commercial MLLW treatment and modification of the T Plant Complex in Alternative Group A is less expensive than construction of a new facility, with DOE doing the majority of the treatment onsite in Alternative Group B. The consolidation of disposal facilities should lead to lower disposal costs – most easily noted in the total alternative group costs between Alternative Groups D and E and Alternative Group A.

**Table 3.21 (sheet 1).** Consolidated Cost Estimates for Alternative Groups A, B, and C (Construction and Operation Cost)

Cost Category	Cost of Alternatives (Millions of Dollars)								
	Group A			Group B			Group C		
	Waste Volume			Waste Volume			Waste Volume		
	Hanford Only	Lower Bound	Upper Bound	Hanford Only	Lower Bound	Upper Bound	Hanford Only	Lower Bound	Upper Bound
LLBGs	267	339	484	268	340	485	267	339	484
CWC	566	566	566	566	566	566	566	566	566
WRAP	710	710	710	710	710	710	710	710	710
T Plant	376	376	376	376	376	376	376	376	376
Commercial MLLW Treatment	229	229	229	17	17	17	229	229	229
New Treatment Capacity	457	457	457	830	830	830	457	457	457
MLLW and Melter Disposal	275	275	424	268	268	429	275	275	424
ILAW Disposal	680	680	680	680	680	680	506	506	506
Post 2046 Costs	103	103	116	110	110	125	103	103	116
Total Operations	3663	3735	4042	3825	3897	4218	3489	3561	3868
Post-Operational Monitoring	75	75	75	75	75	75	75	75	75

**Table 3.21 (sheet 2).** Consolidated Cost Estimates for Alternative Groups D, E, and No Action

Cost Category	Cost of Alternatives (Millions of Dollars)							
	Groups D1, D2, and D3			Groups E1, E2, and E3			No Action <sup>(b)</sup>	
	Waste Volume			Waste Volume			Waste Volume	
	Hanford Only	Lower Bound	Upper Bound	Hanford Only	Lower Bound	Upper Bound	Hanford Only	Lower Bound
LLBGs	(a)	(a)	(a)	(a)	(a)	(a)	268	345
CWC	566	566	566	566	566	566	1090	1090
WRAP	710	710	710	710	710	710	710	710
T Plant	376	376	376	376	376	376	511	511
Commercial MLLW Treatment	229	229	229	229	229	229	17	17
New Treatment Capacity	457	457	457	457	457	457	0	0
MLLW and Melter Disposal	755	777	1076	486	511	829	152	152
ILAW Disposal	(a)	(a)	(a)	506	506	506	706	706
Post 2046 Costs	103	103	116	103	103	116	(b)	(b)
Total Operations	3196	3218	3530	3433	3458	3789	3454	3531
Post-Operational Monitoring <sup>(c)</sup>	75	75	75	75	75	75	75	75

(a) Combined disposal facility – costs included in MLLW and melter disposal.  
 (b) Does not account for costs for storage, treatment, or eventual disposal of waste remaining in storage after 2046.  
 (c) Estimated minimum cost of \$500,000 per year for a 100-year institutional control period (DOE 2002). Maximum cost estimated at \$750,000 per year depending on number of wells and monitoring requirements.

### 3.7 DOE Preferred Alternative

Based on the results of the environmental consequences analyses (as presented in Section 5 and summarized in Section 3.4), cost, and other considerations, DOE has identified its preferred alternative for the HSW EIS. The preferred alternative consists of those actions identified in Alternative Group D<sub>1</sub>. The preferred alternative would be implemented for Hanford and offsite waste up to the Upper Bound volume. Offsite waste would be managed in the same manner as onsite waste. The preferred alternative would be implemented as follows:

**Storage:** The Central Waste Complex will continue to be the primary storage facility for LLW, MLLW, and TRU waste. Consistent with previous decisions, TRU waste retrievably stored in the Low Level Burial Grounds would be retrieved for processing and shipment to WIPP. Until the waste is retrieved, it would continue to be stored in the LLBGs. Newly generated mixed TRU waste from onsite and offsite generators would be stored in RCRA-compliant storage facilities such as CWC and T Plant. Newly generated non-mixed TRU waste from onsite and offsite generators would be stored in several places, such as CWC and T Plant, but remote-handled waste could be stored temporarily in the Low Level Burial Grounds. T Plant would be used to store sludge from the K Basins.

**Treatment:** LLW and MLLW would be treated using a combination of existing capabilities and processes, offsite commercial capabilities, and a modified T Plant. TRU waste would be processed and certified using a combination of the Waste Receiving and Processing Facility, a modified T Plant, and mobile processing facilities (APLs).

**Disposal:** Newly generated LLW, MLLW, ILAW, and WTP melters would be disposed of in a new modular facility near PUREX. This new disposal facility would include a RCRA-compliant liner and a leachate collection/leak detection system. Upon closure, it would be capped with a Modified RCRA Subtitle C Barrier. Waste previously disposed of in the Low Level Burial Grounds would be similarly capped. Existing disposal capacity in the Low Level Burial Grounds would continue to be used as necessary to meet short-term requirements pending construction and operation of the new disposal facility.

In general, waste management activities outlined in Alternative Group D<sub>1</sub> would be operationally efficient, cost-effective, and environmentally preferable as to many types of potential impacts. The differences in impacts among all alternative groups would be relatively minor. However, Alternative Group D<sub>1</sub> appears to offer a combination of low environmental impacts and low cost. Future waste disposal operations would be combined in a single location that could provide a more unified regulatory pathway to construction, operation, and stewardship.

### 3.8 References

40 CFR 141. "National Primary Drinking Water Regulations." Code of Federal Regulations. Online at: [http://www.access.gpo.gov/nara/cfr/waisidx\\_01/40cfr141\\_01.html](http://www.access.gpo.gov/nara/cfr/waisidx_01/40cfr141_01.html)

40 CFR 1500-1508. "Council on Environmental Quality Regulations for Implementing the Procedural Provisions of the National Environmental Policy Act." Code of Federal Regulations. Online at: [http://www.access.gpo.gov/nara/cfr/waisidx\\_01/40cfrv28\\_01.html](http://www.access.gpo.gov/nara/cfr/waisidx_01/40cfrv28_01.html)

46 FR 18026. "Forty Most Asked Questions Concerning CEQ's National Environmental Policy Act Regulations: 1. Range of Alternatives." March 23, 1981. Online at: <http://ceq.eh.doe.gov/nepa/regs/40/40p3.htm>

64 FR 61615. "Record of Decision: Hanford Comprehensive Land-Use Plan Environmental Impact Statement (HCP EIS)." *Federal Register* (November 12, 1999). Online at: <http://www.gpoaccess.gov/fr/index.html>

65 FR 10061. "Record of Decision for the Department of Energy's Waste Management Program: Treatment and Disposal of Low-Level Waste and Mixed Low-Level Waste; Amendment of the Record of Decision for the Nevada Test Site." *Federal Register* (February 25, 2000). Online at: <http://www.gpoaccess.gov/fr/index.html>

68 FR 1052. "Notice of Intent to Prepare an Environmental Impact Statement for Retrieval, Treatment, and Disposal of Tank Waste and Closure of Single-Shell Tanks at the Hanford Site, Richland, Washington." *Federal Register* (January 8, 2003). Online at: <http://www.gpoaccess.gov/fr/index.html>

Aromi, E. S. and R. D. Freeberg. 2002. *Request for CHG Support Concerning Immobilized Low-Activity Waste Choices*. CHG-0203620R2, CH2M Hill Hanford Group, Richland, Washington.

Bryce, R. W., C. T. Kincaid, P. W. Eslinger, and L. F. Morasch (eds.). 2002. *An Initial Assessment of Hanford Impact Performed with the System Assessment Capability*. PNNL-14027, Pacific Northwest National Laboratory, Richland, Washington. Online at: [http://www.pnl.gov/main/publications/external/technical\\_reports/PNNL-14027/PNNL-14027.pdf](http://www.pnl.gov/main/publications/external/technical_reports/PNNL-14027/PNNL-14027.pdf)

Burbank, D. A. 2002. *Conceptual Design Report for Immobilized Low-Activity Waste Disposal Facility, Project W-52 Rev 0*. RPP-7908, Rev. 0A, CH2M Hill Hanford Group, Richland, Washington.

DOE. 1985. *Volume II RCRA Part B Permit Application Low-Level Burial Grounds and Retrievable Storage*. U.S. Department of Energy, Richland Operations Office, Richland, Washington. Online at: <http://www2.hanford.gov/ARPIR/common/findpage.cfm?AKey=D196004062>

DOE. 1987. *Final Environmental Impact Statement for Disposal of Hanford Defense High-Level, Transuranic, and Tank Wastes*. DOE/EIS-0113, U.S. Department of Energy, Washington D.C.

DOE. 1993. *Radiation Protection of the Public and the Environment*. DOE Order 5400.5, U.S. Department of Energy, Washington, D.C. Online at: <http://www.directives.doe.gov>

DOE. 1996. *Draft Hanford Remedial Action Environmental Impact Statement and Comprehensive Land Use Plan*. DOE/EIS-0222D, U.S. Department of Energy, Washington, D.C.

DOE. 1997a. *Final Waste Management Programmatic Environmental Impact Statement for Managing Treatment, Storage, and Disposal of Radioactive and Hazardous Waste*. DOE/EIS-0200-F, Vol. 1-5, U.S. Department of Energy, Washington, D.C.

DOE. 1997b. *Waste Isolation Pilot Plant Disposal Phase Final Supplemental Environmental Impact Statement*. DOE/EIS-0026-S-2, U.S. Department of Energy, Carlsbad Area Office, Carlsbad, New Mexico.

DOE. 2002. *Report to Congress – The Cost of Waste Disposal: Life Cycle Cost Analysis of Disposal of Department of Energy Low-Level Radioactive Waste at Federal and Commercial Facilities*. U.S. Department of Energy, Office of Environmental Management, Washington, D.C. Online at: [http://www.envirocareutah.com/pages/pdf/Final\\_LLW\\_Report\\_7\\_08\\_02.pdf](http://www.envirocareutah.com/pages/pdf/Final_LLW_Report_7_08_02.pdf)

DOE-RL. 1989. *Low-Level Burial Grounds Dangerous Waste Permit Application*. DOE/RL-88-20, U.S. Department of Energy, Richland Operations Office, Richland, Washington.

DOE-RL. 2002. *Performance Management Plan for the Accelerated Cleanup of the Hanford Site*. DOE/RL-2002-47, Rev. D, U.S. Department of Energy Richland Operations Office, Richland, Washington. Online at <http://www.hanford.gov/docs/rl-2002-47/rl-2002-47.pdf>

DOE and Ecology. 1996. *Tank Waste Remediation System, Hanford Site, Richland, Washington, Final Environmental Impact Statement*. DOE/EIS-0189, U.S. Department of Energy, Richland, Washington and Washington State Department of Ecology, Olympia, Washington.

Eckerman, K. F. and J. C. Ryman. 1993. *External Exposure to Radionuclides in Air, Water, and Soil, Federal Guidance Report No. 12*. EPA 402-R-93-081, U.S. Environmental Protection Agency, Washington, D.C.

Eckerman, K. F., A. B. Wolbarst, and A. C. B. Richardson. 1988. *Limiting Values of Radionuclide Intake and Air Concentration and Dose Conversion Factors for Inhalation, Submersion, and Ingestion. Federal Guidance Report No. 11*. EPA-520/1-88-020, U.S. Environmental Protection Agency, Washington, D.C.

FH. 2003. *Hanford Site Solid Waste Acceptance Criteria*. HNF-EP-0063, Rev. 9, Fluor Hanford, Inc., Richland, Washington. Online at: <http://www.hanford.gov/wastemgt/wac/acceptcriteria.cfm>

FH. 2004. *Hanford Site Solid Waste Management Environmental Impact Statement Technical Information Document*. HNF-4755, Rev. 2, Fluor Hanford, Inc., Richland, Washington.

Hanford Advisory Board. 1997. *Framing of Issues Disposition of Canyon Facilities Prepared by EnviroIssues for Hanford Advisory Board*. July 11, 1997. Online at: <http://www.hanford.gov/boards/hab/letters/97-016a.htm>

Hartman, M. J., L. F. Morasch, and W. D. Webber, eds. 2002. *Hanford Site Groundwater Monitoring for Fiscal Year 2001*. PNNL-13788, Pacific Northwest National Laboratory, Richland, Washington. Online at: <http://groundwater.pnl.gov/reports/gwrep01/start.htm>

NCRP. 1996. *A Guide for Uncertainty Analysis in Dose and Risk Assessments Related to Environmental Contamination*. NCRP Commentary No. 14, National Council on Radiation Protection and Measurements, Bethesda, Maryland.

Poston, T. M., R. W. Hanf, R. L. Dirkes, and L. F. Morasch (eds.). 2002. *Hanford Site Environmental Report for Calendar Year 2001*. PNNL-13910, Pacific Northwest National Laboratory, Richland, Washington. Online at: <http://hanford-site.pnl.gov/envreport/2001/index.htm>

Richland Environmental Restoration Project. 2001. *Canyon Disposition Initiative Project*. Online at: [http://www.bhi-erc.com/projects/s\\_m/cdi/cdi.htm](http://www.bhi-erc.com/projects/s_m/cdi/cdi.htm)

WDOH and Ecology. 2000. *Draft Environmental Impact Statement. Commercial Low-Level Radioactive Waste Disposal Site, Richland, Washington*. Washington State Department of Health and Washington State Department of Ecology, Olympia, Washington. Online at: <http://www.ecy.wa.gov/pubs/0005010.pdf>

## 4.0 Affected Environment

The purpose of this section is to provide a description of the environment that might be affected by the alternatives discussed in Section 3. Because the Hanford Site is so large, the description includes much of the site itself, as well as the surrounding areas. Information used in this section was taken from the *Hanford Site National Environmental Policy Act (NEPA) Characterization Report* (Neitzel 2002a), unless otherwise noted.

The affected environment section includes the following:

- Land Use
- Meteorology and Air Quality
- Geology, Soils, and Seismology
- Hydrology
- Biology and Ecology
- Cultural Resources
- Socioeconomics
- Noise
- Occupational Safety
- Occupational Radiation Exposure.

### 4.1 Introduction

The focus of solid waste management activities related to the Hanford Solid (Radioactive and Hazardous) Waste Environmental Impact Statement (HSW EIS) is within the existing boundaries of the Hanford Site 200 Areas or at the Environmental Restoration and Disposal Facility (ERDF). Located on the Central Plateau (i.e., 200 Area Plateau) of the Hanford Site, the 200 East and 200 West Areas are approximately 8 and 11 km (5 and 7 mi), respectively, south and west of the Columbia River. The 200 Areas facilities were built to process irradiated fuel from the production reactors. Subsequent liquid wastes, produced as a result of the fuel processing, were placed in tanks or disposed of in cribs, ponds, or ditches in the 200 Areas. Treatment, storage, and disposal of solid wastes are accomplished in the 200 Areas.

The U.S. Department of Energy (DOE) Hanford Site (Figure 4.1) lies within the semi-arid Pasco Basin of the Columbia Plateau in southeastern Washington State. The site occupies an area of about 1,517 km<sup>2</sup> (586 mi<sup>2</sup>) north of the confluence of the Yakima River with the Columbia River. The Hanford Site measures approximately 50 km (31 mi) north to south and 40 km (25 mi) east to west. The major portion of this land, with restricted public access, provides a buffer for the smaller areas currently used for nuclear materials storage, waste storage, and waste disposal.

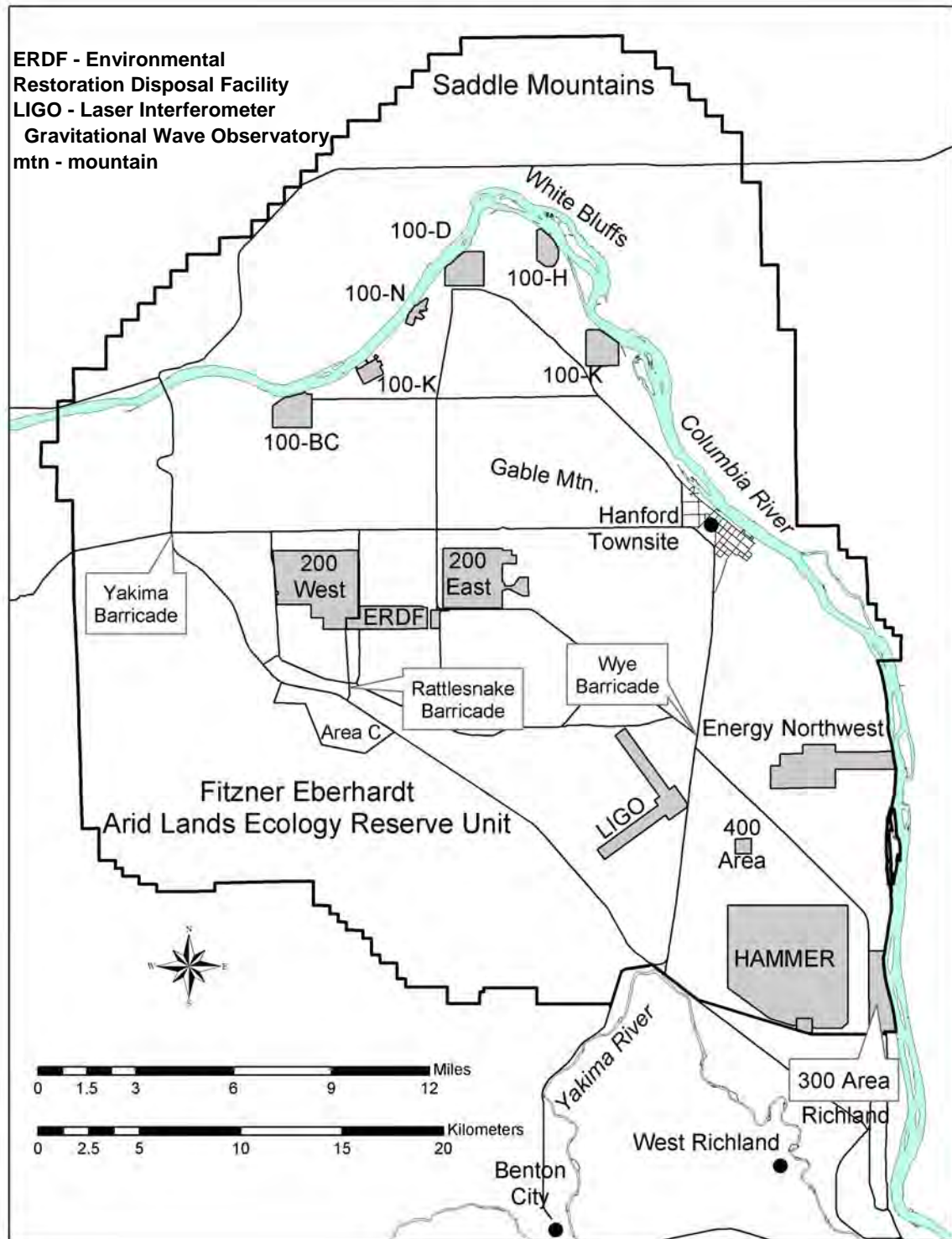


Figure 4.1. Department of Energy – Hanford Site (after Neitzel 2002a)



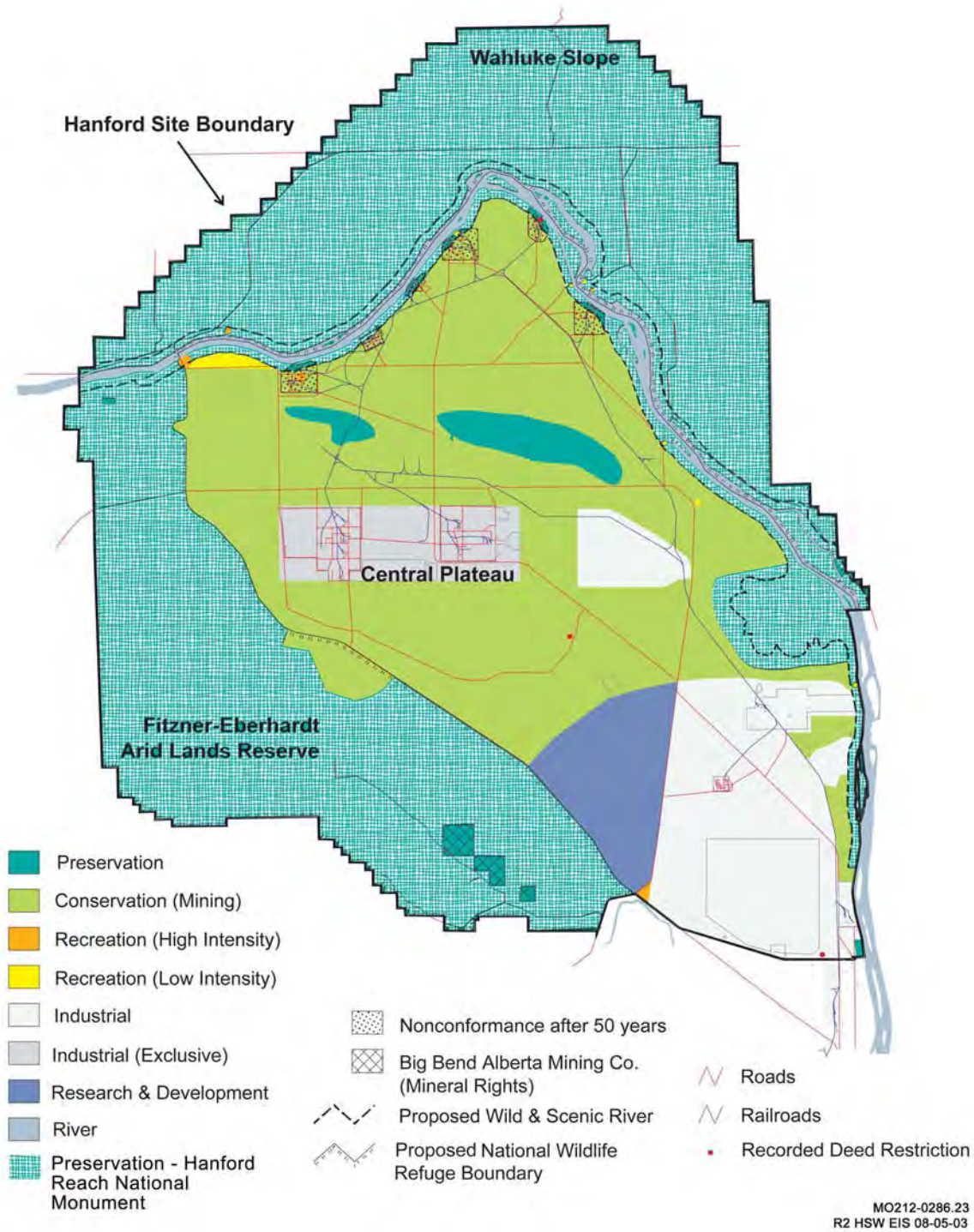
The Columbia River flows through the northern part of the Hanford Site and, turning south, forms part of the eastern site boundary. The Yakima River runs near the southern boundary of the Hanford Site, joining the Columbia River at the city of Richland that bounds the Hanford Site on the southeast. Rattlesnake Mountain, Yakima Ridge, and Umtanum Ridge form the southwestern and western boundaries. Saddle Mountain constitutes the northern boundary of the Hanford Site. Two small east-west ridges, Gable Butte and Gable Mountain, rise above the plateau in the central part of the Hanford Site. Adjoining lands to the west, north, and east are principally agricultural and rangeland. The cities of Kennewick, Pasco, and Richland (Tri-Cities) and the city of West Richland constitute the nearest population centers and are located south-southeast of the Hanford Site.

## 4.2 Land Use

DOE completed the Hanford Comprehensive Land-Use Plan Environmental Impact Statement (HCP EIS; DOE 1999) in September 1999. A Record of Decision (ROD) was issued on November 2, 1999 (64 FR 61615), which adopted the Preferred Alternative as discussed in the EIS. The purpose of this land-use plan and its implementing policies and procedures is to facilitate decision-making about Hanford Site uses and facilities over at least the next 50 years. The Preferred Alternative map from the Final HCP EIS ROD shown in Figure 4.2 represents the DOE future land-management values, goals, and objectives. The land-use plan consists of several key elements that are included in the DOE Preferred Alternative in the Final HCP EIS (DOE 1999). These elements include a land-use map that addresses the Hanford Site as five geographic areas—Wahluke Slope, Columbia River Corridor, Central Plateau, all other areas of the site, and the Fitzner/Eberhardt Arid Lands Ecology Reserve (ALE). The key elements of the Hanford Comprehensive Land-Use Plan include a map that depicts the planned future uses, a set of land-use designations defining the allowable uses for each area of the Hanford Site, and the planning and implementing policies and procedures that will govern the review and approval of future land uses. Together these four elements create the Hanford Comprehensive Land-Use Plan. Much of the land is undeveloped, providing a buffer area for the smaller operations areas. Public access to most facility areas is restricted.

The key features of the Hanford Site that form the basis for the five geographic areas used in the environmental impact analysis and land-use plans are summarized as follows:

**Wahluke Slope.** The area north of the Columbia River and the Hanford Site proper encompasses approximately 357 km<sup>2</sup> (138 mi<sup>2</sup>) of relatively undisturbed or recovering shrub-steppe habitat managed by the U.S. Fish and Wildlife Service (FWS) for DOE. These lands consist of two overlay wildlife management units within the Hanford Reach National Monument/Saddle Mountain National Wildlife Refuge, the 130 km<sup>2</sup> (50 mi<sup>2</sup>) Saddle Mountain Unit, and the 225 km<sup>2</sup> (87 mi<sup>2</sup>) Wahluke Unit. Portions of the Saddle Mountain Unit, which is closed to public access, still serve as buffer areas for the Hanford Site. The Wahluke Unit is open to public recreational access. A small strip of land approximately 1.62 km<sup>2</sup> (0.63 mi<sup>2</sup>) located between State Route (SR) 243 and the Columbia River west of SR 24 is managed by the Washington State Department of Fish and Wildlife.



**Figure 4.2.** DOE Preferred Alternative for Land Use on the Hanford Site from the Final Hanford Comprehensive Land-Use Plan EIS Record of Decision (64 FR 61615)

**Columbia River Corridor.** The 111.6 km<sup>2</sup> (43.1 mi<sup>2</sup>) Columbia River Corridor, which is adjacent to and runs through the Hanford Site, is used for boating, water skiing, fishing, and hunting of upland game birds and migratory waterfowl. Although public access is allowed on certain islands, access to other islands and adjacent areas is restricted because of unique habitats and the presence of cultural resources.

The area within the Columbia River Corridor known as the Hanford Reach includes a quarter mile (402-m) strip of land on either side of the Columbia River, as well as the islands and water surface area. Along the southern shoreline of the Columbia River Corridor, the 100 Areas occupy approximately 68 km<sup>2</sup> (26 mi<sup>2</sup>). The facilities in the 100 Areas include nine retired plutonium production reactors, associated facilities, and structures. In the vicinity of the 100-H Area, closure permit restrictions of the Resource Conservation and Recovery Act (RCRA) of 1976 (42 USC 6901 et seq.) that are associated with the 183-H Solar Evaporation Basins have been instituted. Institutional controls are expected for the RCRA post-closure and Comprehensive Environmental Response, Compensation, and Liability Act (CERCLA) of 1980 (42 USC 9601 et seq.) remediation areas.

**Central Plateau.** The 200 East and 200 West Areas occupy approximately 51 km<sup>2</sup> (19.5 mi<sup>2</sup>) in the Central Plateau (the 200 Area Plateau) of the Hanford Site. Facilities located on the 200 Area Plateau were built to process irradiated fuel from the production reactors. The operation of these facilities resulted in the need for treatment, storage, and disposal facilities for radioactive and hazardous wastes. Unplanned releases of radioactive and non-radioactive waste have contaminated some parts of the 200 Areas. The U.S. Navy also uses Hanford nuclear waste treatment, storage, or disposal facilities. Institutional controls are expected for the Central Plateau.

A commercial LLW disposal facility, operated by US Ecology, Inc., currently occupies 0.4 km<sup>2</sup> (0.16 mi<sup>2</sup>) of the 200 Area Plateau. The facility is located on a portion of the 100 ac (originally 1000 ac) leased by the State of Washington from the federal government and subleased to US Ecology, Inc.

**All Other Areas.** All Other Areas comprise 689 km<sup>2</sup> (266 mi<sup>2</sup>) and contain the 300, 400, and 1100 Areas; Energy Northwest facilities; and a section (2.6 km<sup>2</sup> [1 mi<sup>2</sup>]) of land currently owned by the State of Washington for the disposal of hazardous substances.

The Hanford 1100 Area and the Hanford railroad southern connection (from Horn Rapids Road to Columbia Center) have been transferred from DOE ownership to Port of Benton ownership to support future economic development. Although the 1100 Area is no longer under DOE control, it was included in the HCP EIS to support the local governments with their State Environmental Policy Act (SEPA) EIS analyses of the Hanford sub-area of Benton County under the State of Washington Growth Management Act (RCW 36.70A).

The 300 Area is located just north of the city of Richland and covers 1.5 km<sup>2</sup> (0.6 mi<sup>2</sup>). The 300 Area is the site of former reactor fuel fabrication facilities and is also the principal location of nuclear research and development facilities serving the Hanford Site.

The 400 Area, located southeast of the 200 East Area, is the site of the Fast Flux Test Facility (FFTF). DOE has decided to permanently shut down this facility.

Energy Northwest currently operates Columbia Generating Station on land leased from DOE. The land is approximately 10 km (6 mi) north of the city of Richland. The land was leased for the operation of three nuclear power plants. Construction of two of the plants was halted. Other industrial options for the site are currently being considered. Under the terms of the lease agreements, DOE would need to approve alternative uses of the land.

In 1980, the federal government sold a 2.6 km<sup>2</sup> (1 mi<sup>2</sup>) section of land (known as Section 1.0) south of the 200 East Area, near SR 240, to the State of Washington for the purpose of non-radioactive hazardous waste disposal. To date, this parcel has not been used for hazardous waste disposal. The deed requires that if it were used for any purpose other than hazardous waste disposal, ownership would revert to the federal government.

Additional activities in the All Other Areas include:

- (1) *A specialized training center:* The Hazardous Materials Management and Emergency Response (HAMMER) Volpentest Training and Education Center is used to train hazardous materials response personnel. It is located north of the former 1100 Area and covers about 32 ha (80 ac).
- (2) *A regional law-enforcement training facility:* The Hanford Patrol Training Academy, located adjacent to HAMMER, provides a range of training environments including classrooms, library resources, practice shoot houses, an exercise gym, and an obstacle course.
- (3) *A national research facility:* The Laser Interferometer Gravitational Wave Observatory (LIGO), built by the National Science Foundation for scientific research, is designed to detect cosmic gravitational waves. The facility consists of two optical tube arms, each 4 km (2.5 mi) long, arrayed in an L shape, and is extremely sensitive to vibrations.
- (4) *Fitzner/Eberhardt Arid Lands Ecology (ALE) Reserve Unit:* The 308.7 km<sup>2</sup> (119.2 mi<sup>2</sup>) ALE, a Research Natural Area, is part of the Hanford Reach National Monument and is managed by the U.S. Fish and Wildlife Service (FWS). ALE is located in the southwestern portion of the Hanford Site and is managed as a wildlife reserve and environmental research area. The public is generally restricted from the reserve.

#### **4.2.1 Hanford Reach National Monument**

On June 9, 2000, portions of the Hanford Site including ALE, Saddle Mountain Wildlife Refuge, Wahluke Slope, White Bluffs, the sand dune area northwest of the Energy Northwest site, historic structures (including homesteads from small towns established along the riverbanks in the early 20<sup>th</sup> century), and land 0.4 km (¼ mi) inland on the south and west shores of the 82-km (51-mi) long Hanford Reach, the last free-flowing, non-tidal stretch of the Columbia River, were designated as a National Monument (Figure 4.3) by President Clinton (65 FR 37253). Also included in the 78,900-hectare

(195,000-acre) monument were the McGee Ranch and Riverlands areas and the federally owned islands within that portion of the Columbia River.

On June 14, 2001, U.S. Department of Energy, Richland Operation Office (DOE-RL) and the FWS signed an amended Memorandum of Understanding (MOU) addressing management responsibilities for the Hanford Reach National Monument. As a result of the MOU, the FWS is the lead agency in producing a Comprehensive Conservation Plan (CCP) for management of the Hanford Reach National Monument. Development of the CCP will be a public process, including input from local governments, Native American Tribes, stakeholders, and others, including a Federal Advisory Committee for the Hanford Reach National Monument. The DOE will participate in writing the CCP and, in cooperation with the FWS, approve the plan. Under the MOU, which is intended to remain in effect for 25 years, DOE and the FWS will produce agreements for site access, security, emergency preparedness, mutual assistance, wildland fire response, and cultural and biological resource management.

#### **4.2.2 200 Areas**

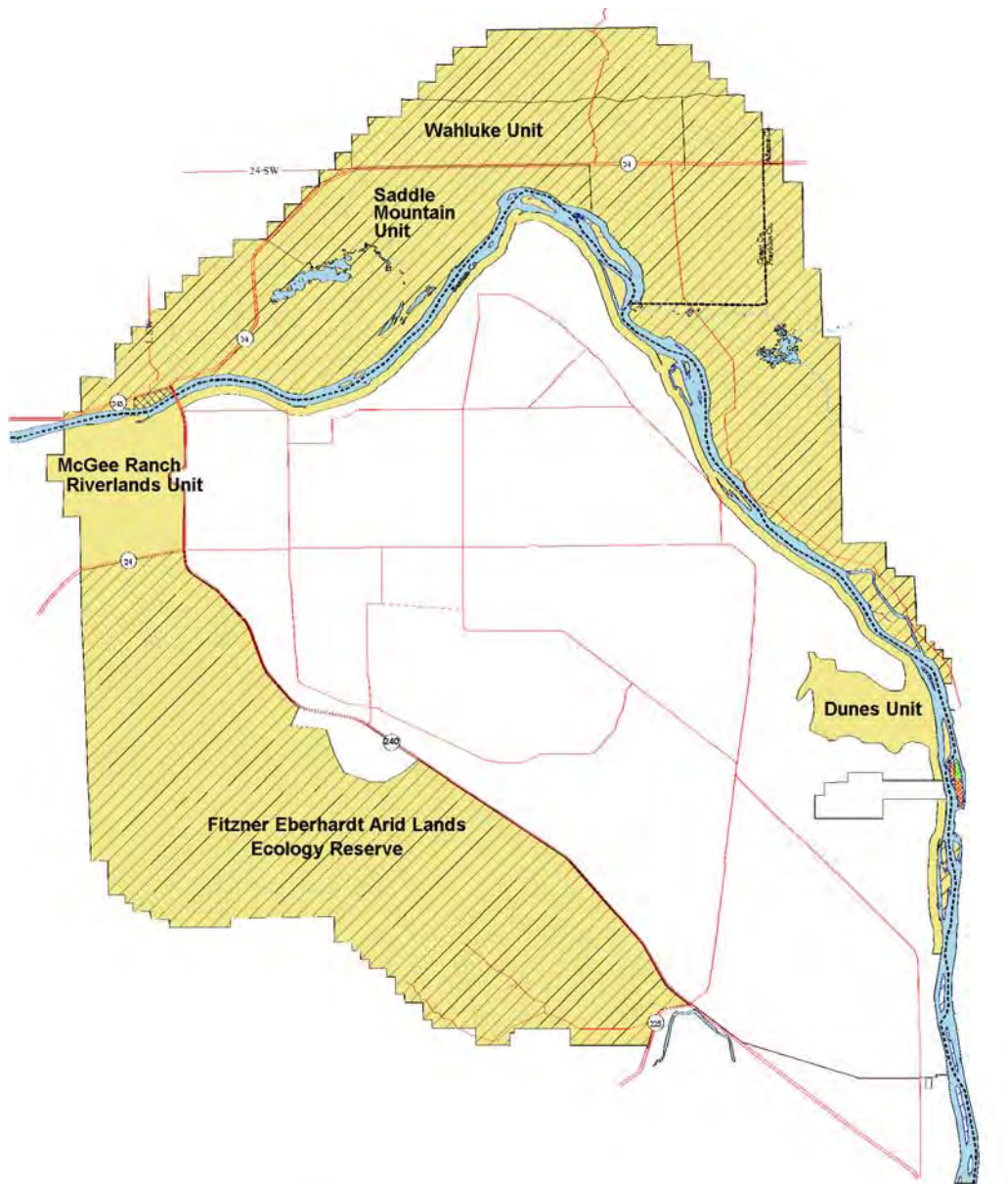
The focus of the HSW EIS is on waste storage, treatment, and disposal activities. For a description of the facilities, refer to Section 2. The Central Waste Complex (CWC) is located in the 200 West Area (Figure 4.4). Low-level waste (LLW), mixed low-level waste (MLLW), and transuranic (TRU) waste from onsite and offsite generators are stored in CWC pending treatment or disposal.

The Waste Receiving and Processing Facility (WRAP) is located in the 200 West Area. It began operations in 1997 and can process TRU waste, certify TRU waste and LLW for disposal, and provide limited treatment of MLLW. The 4,800 m<sup>2</sup> (52,000 ft<sup>2</sup>) facility is located near the CWC, and is designed to process 6,800 drums and 70 boxes of waste annually for 30 years (Poston et al. 2001).

T Plant Complex, located in the northeast corner of the 200 West Area, consists of two major facilities: T Plant canyon and 2706-T Facility. T Plant Complex is used for waste verification, decontamination of equipment, repackaging of radioactive wastes, and storage of pressurized water reactor spent fuel from an offsite reactor. It is also capable of macroencapsulation of debris and contaminated equipment, and neutralization and repackaging of organic and inorganic lab packs. Twenty-seven metric tons (30 tons) of spent nuclear reactor fuel from Shippingport, Pennsylvania, stored at T Plant Complex, are being moved to the Hanford Canister Storage Building. DOE ultimately plans to ship this fuel to Yucca Mountain. K Basins sludge will be moved to T Plant and stored in cells.

The 200 Areas Effluent Treatment Facility (ETF), located in the 200 East Area (Figure 4.5), provides treatment and storage for hazardous and radioactive liquid waste. Liquid effluents are treated to remove metals, radionuclides, and ammonia, as well as to destroy organic compounds. The facility, in operation since 1995, is capable of treating 570 L (150 gal) per minute. Treated effluent is stored in verification tanks, sampled and analyzed, and discharged via pipeline to the State-Approved Land Disposal Site (SALDS), north of the 200 West Area or to the Treated Effluent Disposal Facility (TEDF) east of the 200 East Area (Poston et al. 2002).





**Figure 4.3.** Hanford Reach National Monument

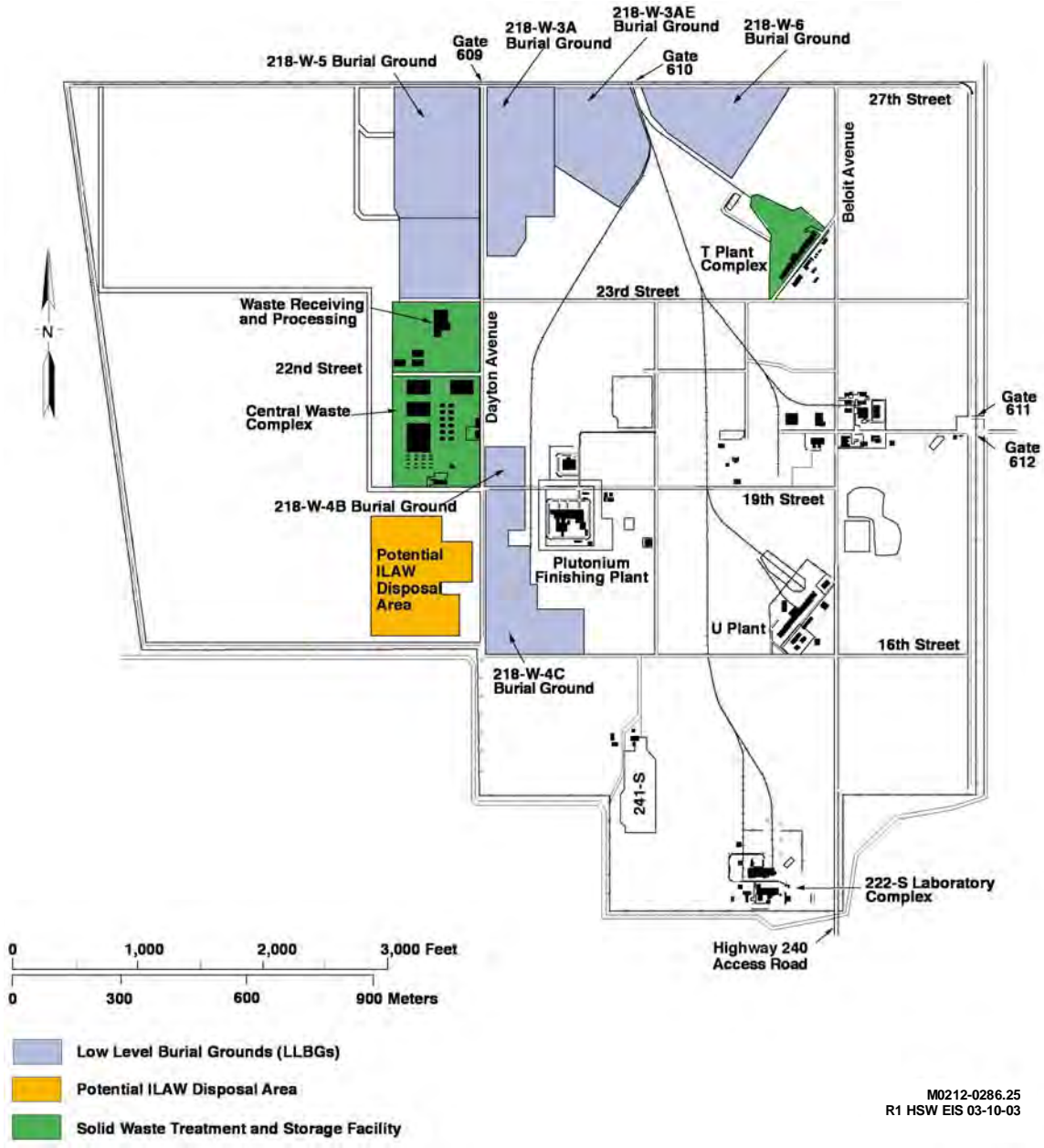
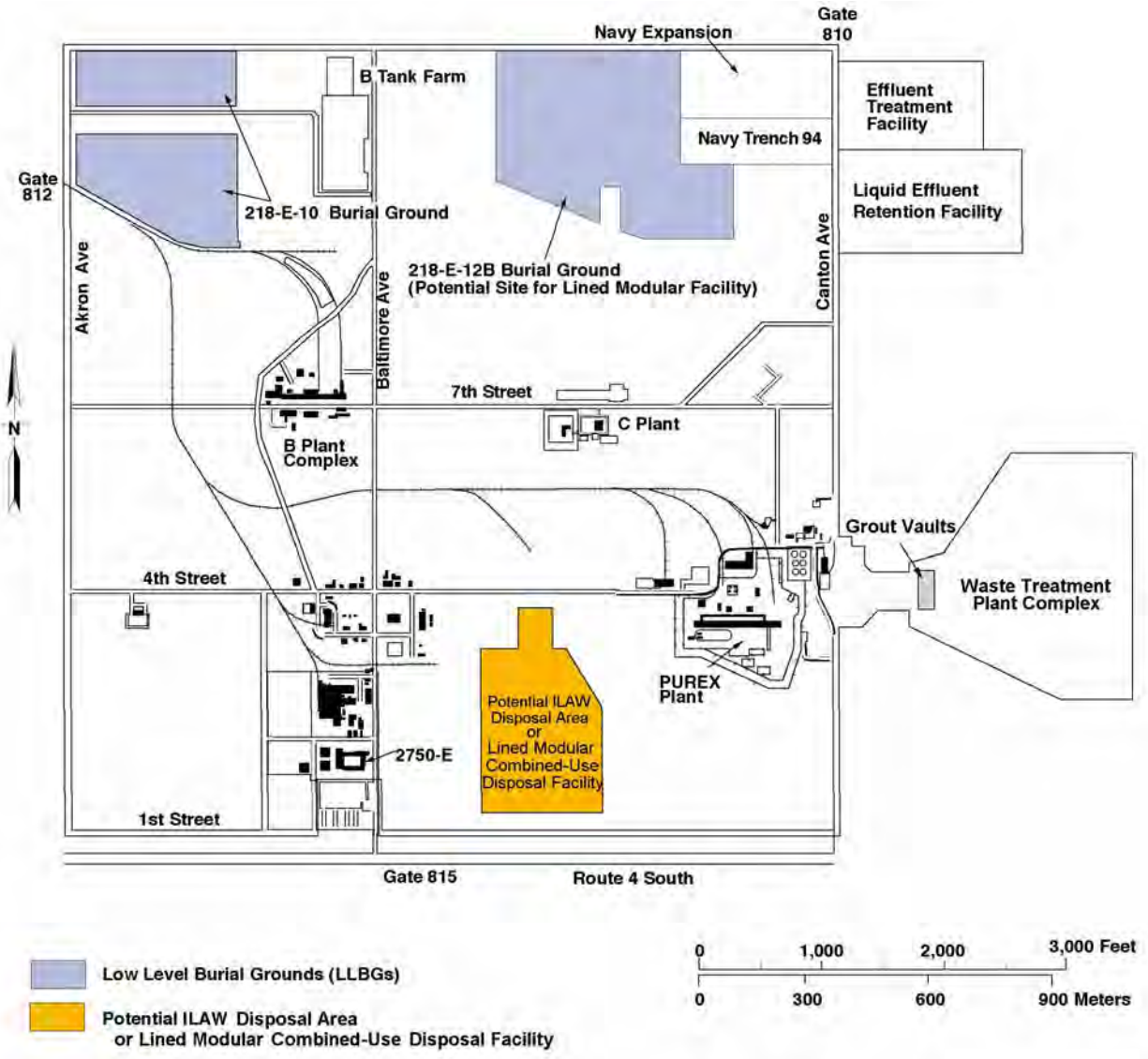


Figure 4.4. 200 West Area



M0212-0286.12a  
R2 HSW EIS 09-18-03

**Figure 4.5.** 200 East Area

The Liquid Effluent Retention Facility (LERF), located in the 200 East Area, consists of three surface impoundments for the temporary storage of process condensate from the 242-A Evaporator and other aqueous wastes. Each basin has a capacity of 29.5 million L (7.8 million gal) and is constructed of two flexible high-density polyethylene membrane liners. Beneath the secondary liner is a soil/bentonite barrier. Each basin is covered by a mechanically tensioned floating membrane cover, designed to minimize evaporation of the contents and screen unwanted material from entering the basin. The facility began operation in 1994 and receives liquid waste from the RCRA- and CERCLA-regulated cleanup activities.



The 200 Areas Treated Effluent Disposal Facility (TEDF) began operation in 1995 and is a collection and disposal system for permitted waste streams. TEDF has a capacity of 12,900 L/min (3,400 gal/min). Effluent to the ponds must meet drinking water standards before discharge.

The Low Level Burial Grounds (LLBGs) are eight separate waste disposal areas located in the 200 Areas. Information summarizing specifics concerning the LLBGs are found in Appendix D.

The Biological Control Program was established in 1999 to control the growth of deep-rooted vegetation over contaminated and potentially contaminated waste sites. Deep-rooted vegetation growing on or near contaminated waste sites can take up radionuclides and other contaminants into their roots and transport them to the surface. Those contaminants can subsequently spread outside controlled areas as the plants are eaten by animals or are transported by weather. As part of the Biological Control Program, herbicides are applied to kill deep-rooted plants and noxious weeds. The effectiveness of the program is directly related to the timeliness of herbicide application. Spraying herbicides is typically performed in all seasons of the year except deep winter, although the early spring application is most critical, as all later applications depend on it for effectiveness. The elimination of contaminated plant species reduces the number of potential mechanisms for spreading contaminants, as well as reducing biological uptake by insects, small mammals, and birds. Selective herbicides are sometimes applied to minimize deep-rooted vegetation, while allowing shallow-rooted vegetation to remain for erosion control and evapotranspiration (soil water removal). The 200 Areas, including some LLBGs, contain relatively small areas of surface contamination as a result of biotic intrusion by deep-rooted plants or burrowing animals. Surface contamination is present in three of the older LLBGs (218-E-10, 218-E-12B, and 218-W-3AE) and amounts to less than 0.1 ha (0.25 ac) of contaminated surface area compared to a total of about 100 ha (250 ac) in the 200 East and 200 West Areas. As part of the Biological Control Program, areas of underground contamination, such as the LLBGs, cribs, ponds, ditches, and inactive disposal sites, are cleaned up and stabilized as needed to prevent further spread of surface contamination. Areas of surface contamination are posted, monitored, and surveyed at least annually to document their radiological status. Personal protective clothing and special procedures are required for entry into these surface contamination areas. However, surveys of the 200 Area contaminated soil sites during 2001 indicated that radionuclide concentrations were below soil concentration limits established to protect onsite workers (Poston et al. 2002).

The Environmental Restoration Disposal Facility (ERDF) for CERCLA cleanup wastes is located in the 200 Area Plateau between the 200 East and 200 West Areas (Figure 4.1). It is used for the disposal of radioactive, hazardous, dangerous, and mixed wastes generated during waste management and remediation activities at the Hanford Site. ERDF began operation in July 1996 and currently consists of 4 cells, covering an area of approximately 20 ha (50 ac). Two cells received wastes until September 2000 and are no longer active. The third cell began receiving wastes in June 2000, and the fourth cell has not been used to date (Poston et al. 2002). Alternatives proposed in the HSW EIS include the use of a site near ERDF for disposal of operational wastes.

Alternatives for disposal of ILAW include newly constructed trenches on a site just south of the CWC (Figure 4.4), new trenches southwest of the Plutonium-Uranium Extraction (PUREX) Facility in the 200 East Area, or one of several potential combined-use disposal facilities (Figure 4.5).

Area C, a large polygonal area approximately 368 ha (909 ac) located adjacent to the south side of State Route (SR) 240 and centered approximately on the intersection of Beloit Avenue and SR 240, has been identified as a borrow-use area for the fine-grade silt loam and coarse-grade basalt needed to cap the LLBGs (Figure 4.1).

## 4.3 Meteorology and Air Quality

Air resources addressed in this section include climate and meteorology, atmospheric dispersion, and ambient air quality.

### 4.3.1 Climate and Meteorology

The Hanford Site is categorized as a mid-latitude semiarid region. Summers are warm and dry, while winters are cool with occasional precipitation. Intense heating during the day and nocturnal cooling produce large diurnal temperature variations. The Cascade Mountain range, beyond Yakima to the west, greatly influences the climate of the Hanford area by means of its rain shadow effect. The Cascade Mountains limit the Pacific Ocean maritime influence by blocking the passage of frontal systems and causing less rain and cloud-cover on the lee (east) side of the mountains. This mountain range also serves as a source of cold air drainage with a considerable effect on the wind regime at the Hanford Site.

Climatological data for the Hanford Site are compiled at the Hanford Meteorology Station (HMS). The HMS is located just outside the northeast corner of 200 West Area and about 4 km (3 mi) west of the 200 East Area. Data from the HMS are representative of the general climatic conditions for the region and describe the specific climate of the 200 Area Plateau. Meteorological measurements have been made at the HMS since late 1944. Prior to the establishment of the HMS, local meteorological observations were made at the old Hanford townsite (1912 through late 1943) and in Richland (1943-1944). A climatological summary for Hanford is provided in Hoitink et al. (2002). To accurately characterize meteorological differences across the Hanford Site, the HMS operates a network of automated monitoring stations. These stations, which currently number 30, are located throughout the site and in neighboring areas (Figure 4.6). A 124-m (408-ft) instrumented meteorological tower operates at the HMS, Station 21. A 61-m (200-ft) instrumented tower operates at each of the 100-N, 300, and 400 Area meteorology-monitoring sites. Most of the other network stations utilize short-instrumented towers with heights of about 9 m (30 ft). Instrumentation on each tower is described in Table 4.1. Data are collected and processed at each monitoring site and key information is transmitted to the HMS every 15 minutes. This monitoring network has been in full operation since the early 1980s.

**Wind.** Wind data at the HMS are collected at 2.1 m (7 ft) above the ground and at the 15.2-, 61.0-, and 121.9-m (50-, 200-, and 400-ft) levels on the 124-m (408-ft) tower. Each of the three 61-m (200-ft) towers has wind-measuring instrumentation at the 10-, 25-, and 60-m (33-, 82-, and 197-ft) levels. The short towers measure winds at 9.1 m (30 ft) above ground level.

Prevailing wind directions near the surface on the Hanford 200 Area Plateau are from the northwest in all months of the year (Figure 4.7). Winds from the northwest occur most frequently during the winter and summer. Winds from the southwest also have a high frequency of occurrence on the 200 Area Plateau. During the spring and fall, the frequency of winds from the southwest increases and winds from the northwest correspondingly decrease.

Area C, a large polygonal area approximately 368 ha (909 ac) located adjacent to the south side of State Route (SR) 240 and centered approximately on the intersection of Beloit Avenue and SR 240, has been identified as a borrow-use area for the fine-grade silt loam and coarse-grade basalt needed to cap the LLBGs (Figure 4.1).

## 4.3 Meteorology and Air Quality

Air resources addressed in this section include climate and meteorology, atmospheric dispersion, and ambient air quality.

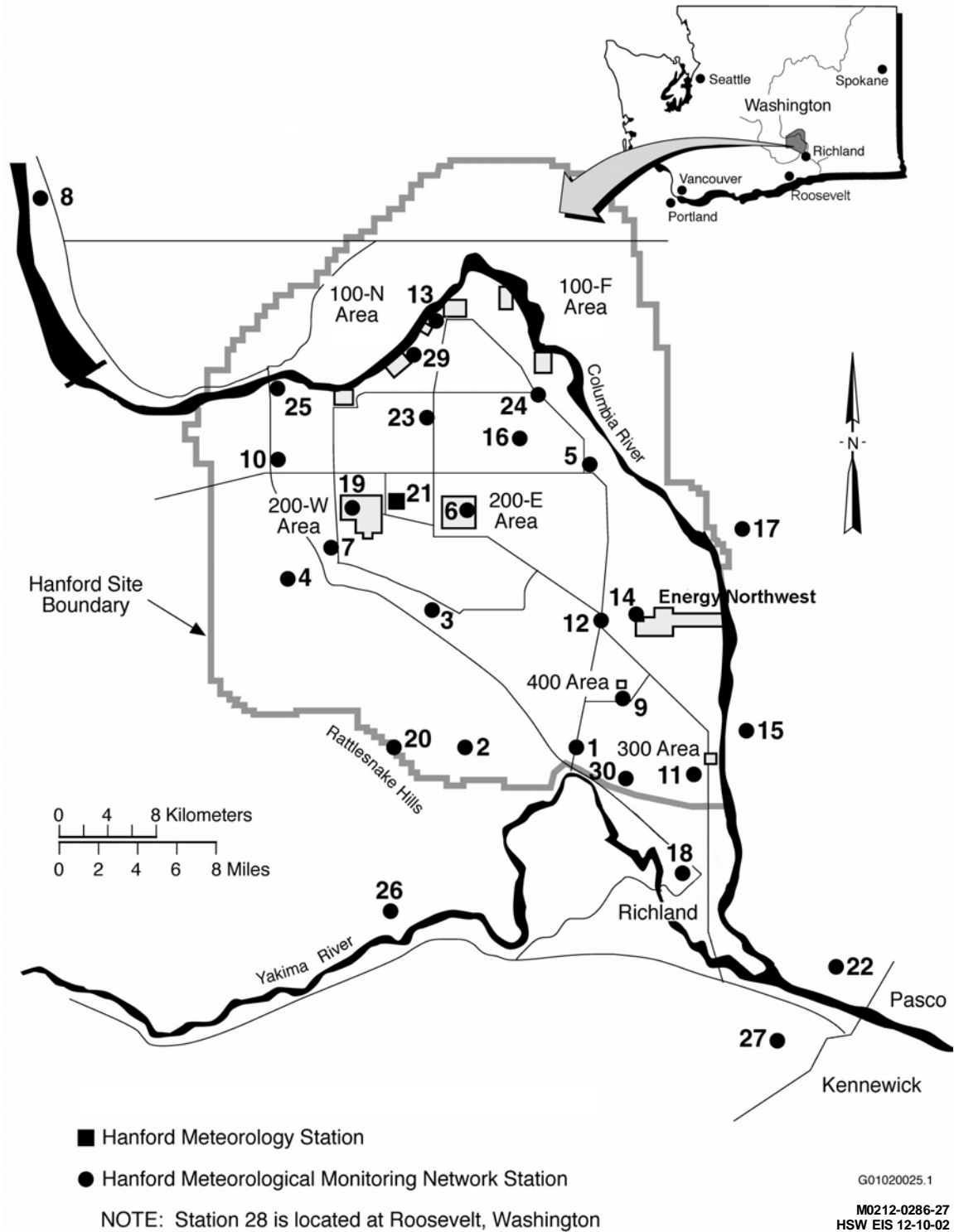
### 4.3.1 Climate and Meteorology

The Hanford Site is categorized as a mid-latitude semiarid region. Summers are warm and dry, while winters are cool with occasional precipitation. Intense heating during the day and nocturnal cooling produce large diurnal temperature variations. The Cascade Mountain range, beyond Yakima to the west, greatly influences the climate of the Hanford area by means of its rain shadow effect. The Cascade Mountains limit the Pacific Ocean maritime influence by blocking the passage of frontal systems and causing less rain and cloud-cover on the lee (east) side of the mountains. This mountain range also serves as a source of cold air drainage with a considerable effect on the wind regime at the Hanford Site.

Climatological data for the Hanford Site are compiled at the Hanford Meteorology Station (HMS). The HMS is located just outside the northeast corner of 200 West Area and about 4 km (3 mi) west of the 200 East Area. Data from the HMS are representative of the general climatic conditions for the region and describe the specific climate of the 200 Area Plateau. Meteorological measurements have been made at the HMS since late 1944. Prior to the establishment of the HMS, local meteorological observations were made at the old Hanford townsite (1912 through late 1943) and in Richland (1943-1944). A climatological summary for Hanford is provided in Hoitink et al. (2002). To accurately characterize meteorological differences across the Hanford Site, the HMS operates a network of automated monitoring stations. These stations, which currently number 30, are located throughout the site and in neighboring areas (Figure 4.6). A 124-m (408-ft) instrumented meteorological tower operates at the HMS, Station 21. A 61-m (200-ft) instrumented tower operates at each of the 100-N, 300, and 400 Area meteorology-monitoring sites. Most of the other network stations utilize short-instrumented towers with heights of about 9 m (30 ft). Instrumentation on each tower is described in Table 4.1. Data are collected and processed at each monitoring site and key information is transmitted to the HMS every 15 minutes. This monitoring network has been in full operation since the early 1980s.

**Wind.** Wind data at the HMS are collected at 2.1 m (7 ft) above the ground and at the 15.2-, 61.0-, and 121.9-m (50-, 200-, and 400-ft) levels on the 124-m (408-ft) tower. Each of the three 61-m (200-ft) towers has wind-measuring instrumentation at the 10-, 25-, and 60-m (33-, 82-, and 197-ft) levels. The short towers measure winds at 9.1 m (30 ft) above ground level.

Prevailing wind directions near the surface on the Hanford 200 Area Plateau are from the northwest in all months of the year (Figure 4.7). Winds from the northwest occur most frequently during the winter and summer. Winds from the southwest also have a high frequency of occurrence on the 200 Area Plateau. During the spring and fall, the frequency of winds from the southwest increases and winds from the northwest correspondingly decrease.



**Figure 4.6.** Hanford Meteorological Monitoring Network (after Hoitink et al. 2002)

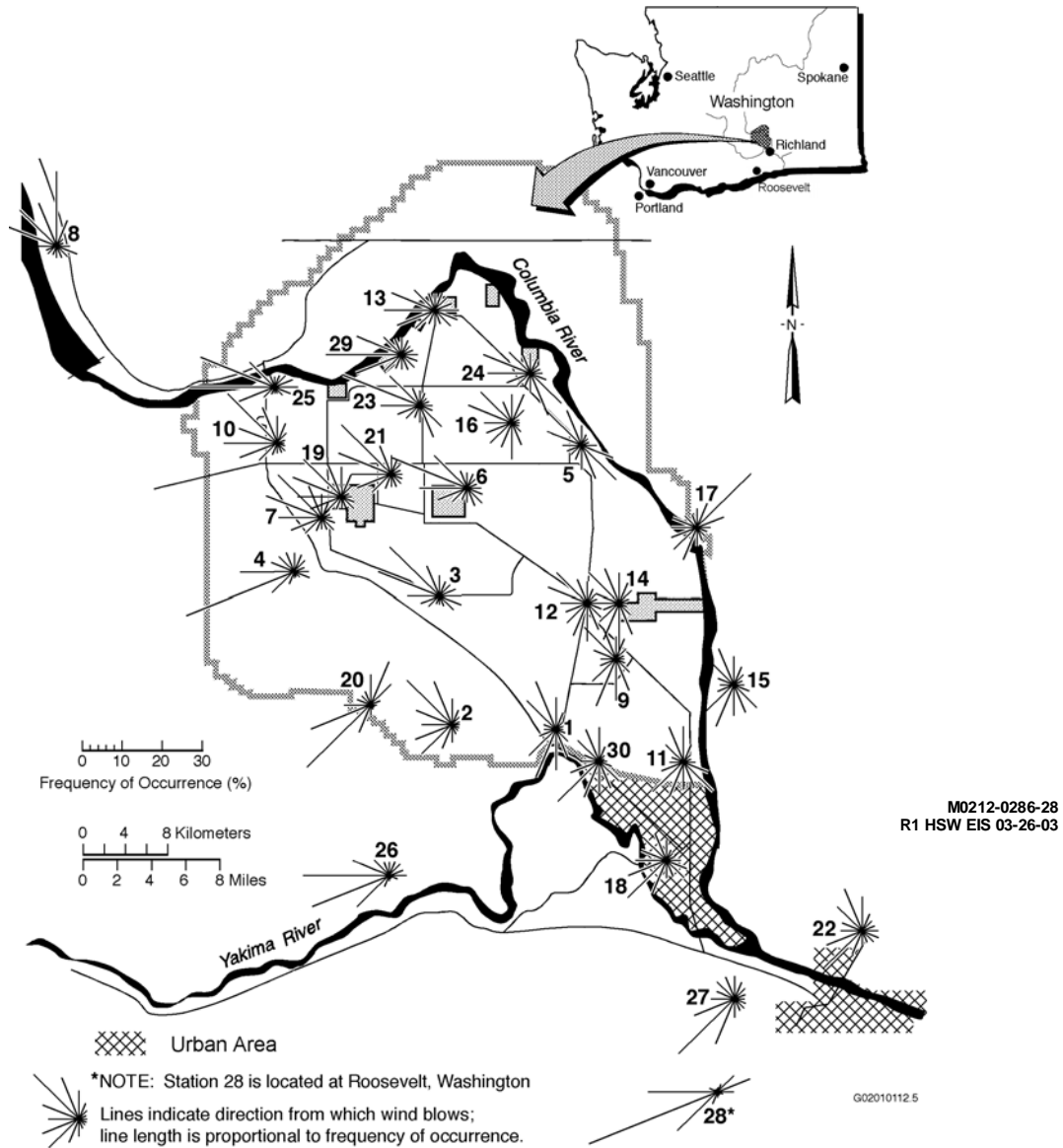
**Table 4.1.** Station Numbers, Names, and Meteorological Parameters for Each Hanford Meteorological Monitoring Network Site (Hoitink et al. 2002)

Site Number	Site Name	Meteorological Parameter
1	Prosser Barricade	WS, WD, T, P
2	Emergency Operations Center	WS, WD, T, P
3	Army Loop Road	WS, WD, T, P
4	Rattlesnake Springs	WS, WD, T, P
5	Edna	WS, WD, T
6	200 East Area	WS, WD, T, P, AP
7	200 West Area	WS, WD, T, P
8	Beverly	WS, WD, T, P
9	Fast Flux Test Facility (61 m or 200 ft)	WD, T, TD, DP, P, AP
10	Yakima Barricade	WS, WD, T, P, AP
11	300 Area (61 m or 200 ft)	WS, WD, T, TD, DP, P, AP
12	Wye Barricade	WS, WD, T, P
13	100-N Area (61 m or 200 ft)	WS, WD, T, TD, DP, P, AP
14	Energy Northwest (Supply System)	WS, WD, T, P
15	Franklin County	WS, WD, T
16	Gable Mountain	WS, WD, T
17	Ringold	WS, WD, T, P
18	Richland Airport	WS, WD, T, AP
19	Plutonium Finishing Plant	WS, WD, T, AP
20	Rattlesnake Mountain	WS, WD, T, P
21	Hanford Meteorology Station (125 m or 410 ft)	WS, WD, T, P, AP
22	Tri-Cities Airport	WS, WD, T, P
23	Gable West	WS, WD, T
24	100-F Area	WS, WD, T, P
25	Vernita Bridge	WS, WD, T
26	Benton City	WS, WD, T, P
27	Vista	WS, WD, T, P
28	Roosevelt, Washington <sup>(a)</sup>	WS, WD, T, P, AP
29	100-K Area	WS, WD, T, P, AP
30	HAMMER	WS, WD, T

**Legend:**

AP - atmospheric pressure	TD - temperature difference (between 10-m and 60-m tower levels)
DP - dew point temperature	WD - wind direction
P - precipitation	WS - wind speed
T - temperature	

(a) Roosevelt is located on the Columbia River 92 km (57 mi) west/southwest of the site.



**Figure 4.7.** Wind Roses at the 9.1-m (30-ft) Level of the Hanford Meteorological Monitoring Network, 1982 to 2001 (after Hoitink et al. 2002)

Monthly and annual joint-frequency distributions of wind direction versus wind speed for the HMS are reported by Hoitink et al. (2002). Monthly average wind speeds at 15.2 m (50 ft) above the ground are lower during the winter months, averaging 2.7 to 3.1 m/s (6 to 7 mph), and highest during the summer, averaging 3.6 to 4.0 m/s (8 to 9 mph). The highest wind speeds at the HMS are usually associated with flow from the southwest. However, the summertime drainage winds from the northwest frequently exceed speeds of 13 m/s (30 mph). The maximum speed of the drainage winds (and their frequency of occurrence) tends to decrease toward the southeast across the Hanford Site.

Surface features have less influence on winds aloft than winds near the surface. However, substantial spatial variations are found in the wind distributions across Hanford at 61 m (200 ft) above ground level (Figure 4.8). For releases at greater heights, the most representative data may come from the closest representative 61-m (200-ft) tower rather than the nearest 9.1-m (30-ft) tower.

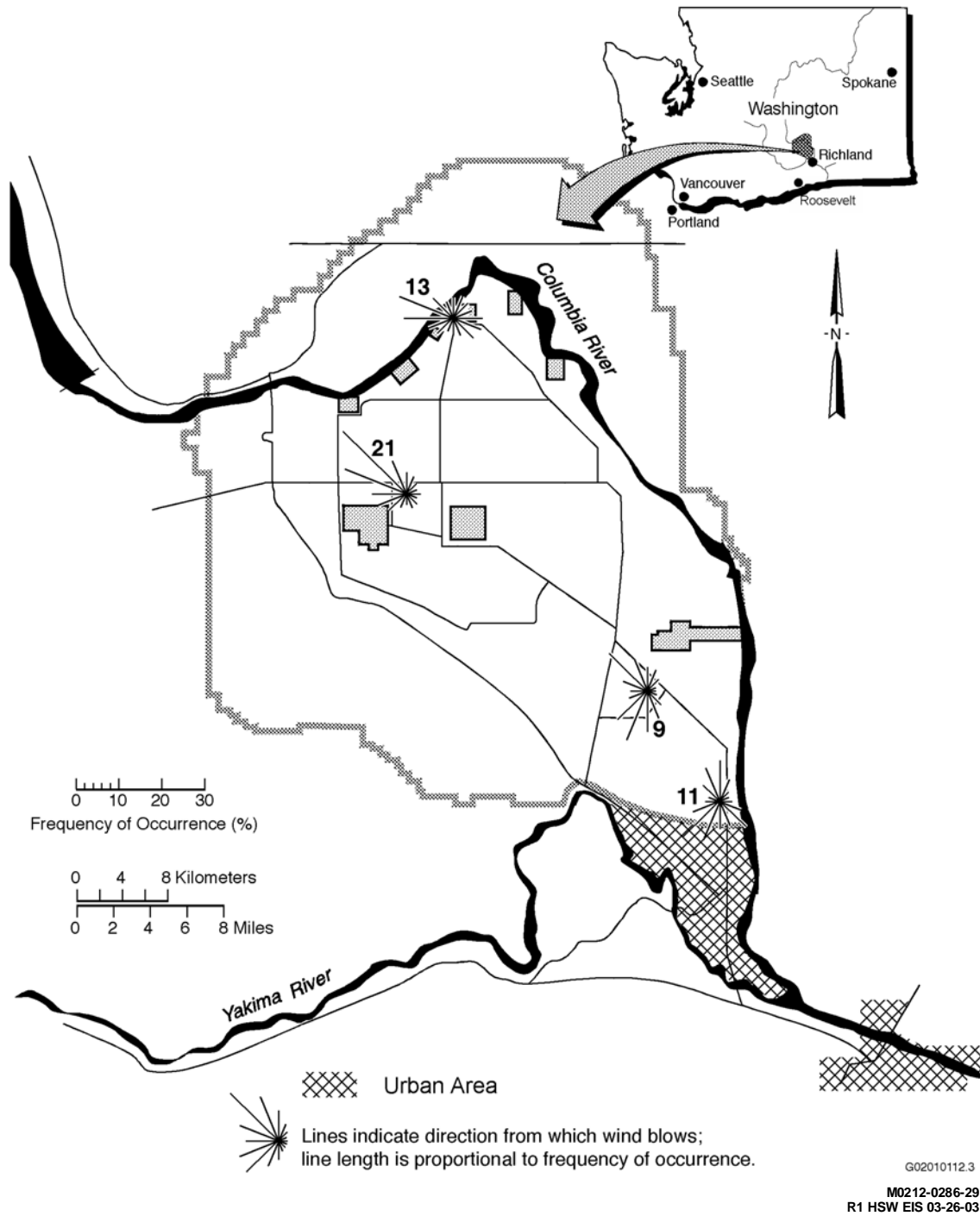
Table 4.2 presents information on number of days, by month and annually, with wind gusts  $\geq 11$  m/s (25 mph) and 16 m/s (35 mph) for the HMS. Table 4.3 presents monthly and annual prevailing wind directions, average wind speeds, and peak wind gusts at the HMS, 1945 through 2001.

**Temperature and Humidity.** Monthly averages and extremes of temperature, dew point, and humidity are presented by Hoitink et al. (2002). Based on data collected from 1946 through 2001, the average monthly temperatures at the HMS range from a low of  $-0.7^{\circ}\text{C}$  ( $31^{\circ}\text{F}$ ) in January to a high of  $24.7^{\circ}\text{C}$  ( $76^{\circ}\text{F}$ ) in July. The highest winter monthly average temperatures were  $6.9^{\circ}\text{C}$  ( $44^{\circ}\text{F}$ ) in February 1958 and February 1991, and the lowest average monthly temperature was  $-11.1^{\circ}\text{C}$  ( $12^{\circ}\text{F}$ ) in January 1950. The highest monthly average temperature was  $27.9^{\circ}\text{C}$  ( $82^{\circ}\text{F}$ ) in July 1985, and lowest summer monthly average temperature was  $17.2^{\circ}\text{C}$  ( $63^{\circ}\text{F}$ ) in June 1953. Ranges of daily maximum temperatures vary from an average of  $2^{\circ}\text{C}$  ( $35^{\circ}\text{F}$ ) in late December and early January to  $36^{\circ}\text{C}$  ( $96^{\circ}\text{F}$ ) in late July. The record maximum temperature is  $45^{\circ}\text{C}$  ( $113^{\circ}\text{F}$ ), and the record minimum temperature is  $-31^{\circ}\text{C}$  ( $-23^{\circ}\text{F}$ ).

Relative humidity/dew point temperature measurements are made every 15 minutes at the 200 Area HMS (Station 21). The annual average relative humidity at the HMS is 55 percent. It is highest during the winter months, averaging about 76 percent, and lowest during the summer, averaging about 36 percent. The annual average dewpoint temperature at the HMS is  $1^{\circ}\text{C}$  ( $34^{\circ}\text{F}$ ). In the winter the dewpoint temperature averages about  $-3^{\circ}\text{C}$  ( $27^{\circ}\text{F}$ ), and in the summer it averages about  $6^{\circ}\text{C}$  ( $43^{\circ}\text{F}$ ).

**Precipitation.** Precipitation measurement records have been kept at the HMS since 1945. Average annual precipitation at the HMS is 17 cm (6.8 in.). In the wettest year on record, 1995, 31.3 cm (12.3 in.) of precipitation was measured; in the driest year, 1976, only 7.6 cm (3 in.) was measured. Most precipitation occurs during the late autumn and winter, with more than half of the annual amount occurring from November through February. Average snowfall ranges from 0.25 cm (0.1 in.) in October to a maximum of 13.2 cm (5.2 in.) in December and decreases to 0.8 cm (0.3 in.) in March. Snowfall accounts for about 38 percent of all precipitation from December through February.

**Fog and Visibility.** Fog has been recorded during every month of the year on the 200 Area Plateau; however, 89 percent of the occurrences are from November through February, with less than 3 percent from April through September. Fog is reported any time horizontal visibility is reduced to 9.6 km (6 mi) or less because of the suspension of water droplets in the surface layer of the atmosphere. Dense fog is reported when horizontal visibility is reduced to 0.4 km (0.25 mi) or less.



**Figure 4.8.** Wind Roses at the 60-m (197-ft) Level of the Hanford Meteorological Monitoring Network, 1986 to 2001 (after Hoitink et al. 2002)



**Table 4.2.** Number of Days with Peak Gusts Above Specific Thresholds at 15-m (50-ft) Level, 1945 through 2001 (Hoitink et al. 2002)

Month	Days with Peak Gusts $\geq 11$ m/s (25 mph)					Days with Peak Gusts $\geq 16$ m/s (35 mph)				
	Avg	Max	Year	Min	Year	Avg	Max	Year	Min	Year
January	7.6	21	1953	0	1985 <sup>(a)</sup>	4.0	14	1953	0	1985 <sup>(a)</sup>
February	8.6	17	1976 <sup>(a)</sup>	2	1952 <sup>(a)</sup>	3.7	14	1976	0	2001 <sup>(a)</sup>
March	13.0	21	1977	4	1992	5.4	14	1997	0	1992
April	16.9	26	1954	8	1946	6.2	12	1972	1	1967
May	18.7	26	1978	9	1945	6.1	10	2000 <sup>(a)</sup>	0	1957
June	19.6	26	1963	11	1950 <sup>(a)</sup>	6.2	12	1973	1	1982
July	19.5	26	1995	11	1955	5.5	11	1994 <sup>(a)</sup>	1	1982 <sup>(a)</sup>
August	15.8	24	2000	7	1945	4.1	12	1996	0	1978 <sup>(a)</sup>
September	11.1	17	1971	7	1975 <sup>(a)</sup>	3.3	7	2001 <sup>(a)</sup>	0	1975
October	8.9	17	1985 <sup>(a)</sup>	3	1987 <sup>(a)</sup>	3.2	11	1997	0	1993 <sup>(a)</sup>
November	8.3	16	1990	0	1979	3.8	10	1998	0	1997 <sup>(a)</sup>
December	7.6	15	1968	0	1985	4.3	11	1957	0	1985 <sup>(a)</sup>
Annual	155.8	192	1999	123	1952	55.9	83	1999 <sup>(a)</sup>	31	1978

(a) Most recent of multiple occurrences.

**Table 4.3.** Monthly and Annual Prevailing Wind Directions, Average Speeds, and Peak Gusts at 15-m (50-ft) Level, 1945 through 2001 (Hoitink et al. 2002)

Month	Prevailing Direction	Average Speed (mph)	Highest Average (mph)	Year	Lowest Average (mph)	Year	Peak Gusts		
							Speed (mph)	Direction	Year
January	NW	6.3	10.3	1972	2.9	1985	80	SW	1972
February	NW	7.1	11.1	1999	4.6	1963	65	SW	1971
March	WNW	8.2	10.7	1977 <sup>(a)</sup>	5.9	1958	70	SW	1956
April	WNW	8.8	11.1	1972 <sup>(a)</sup>	7.4	1989 <sup>(a)</sup>	73	SSW	1972
May	WNW	8.8	10.7	1983	5.8	1957	71	SSW	1948
June	NW	9.1	10.7	1983 <sup>(a)</sup>	7.7	1950 <sup>(a)</sup>	72	SW	1957
July	NW	8.6	10.7	1983	6.8	1955	69	WSW	1979
August	WNW	8.0	9.5	1996	6.0	1956	66	SW	1961
September	WNW	7.5	9.2	1961	5.4	1957	65	SSW	1953
October	NW	6.6	9.1	1946	4.4	1952	72	SW	1997
November	NW	6.3	10.0	1990	2.9	1956	67	WSW	1993
December	NW	6.0	8.3	1968	3.3	1985	71	SW	1955
Annual	NW	7.6	8.8	1999	6.2	1989	80	SW	Jan-72

(a) Also in earlier years.

Other phenomena causing restrictions to visibility (visibility less than or equal to 9.6-km [6 mi]) include dust, blowing dust, and smoke from field burning. Few such days occur; an average of 5 d/yr have dust or blowing dust and <1 d/yr has reduced visibility from smoke.

**Severe Weather.** The average occurrence of thunderstorms on the 200 Area Plateau is 10 per year. Using the National Weather Service (NWS) criteria for classifying a thunderstorm as severe (that is, hail with a diameter  $\geq 19$  mm [3/4 in.] or wind gusts of  $\geq 25.9$  m/s [58 mph]), only 1.9 percent of all thunderstorm events surveyed at the HMS have been “severe” storms, and they met the NWS criteria based on their wind gusts. High-speed winds at Hanford are more commonly associated with strong cold frontal passages. In rare cases, intense low-pressure systems can generate winds of near hurricane force. Estimates of the extreme winds, based on peak gusts, are given by Hoitink et al. (2002).

The National Climatic Data Center maintains a database that provides information on the incidence of tornados reported in each county in the United States. (This database can be accessed via the Internet at <http://www.ncdc.noaa.gov/ol/climate/severeweather/extremes.html>.) This database reports that in the 10 counties closest to the Hanford Site (Benton, Franklin, Grant, Adams, Yakima, Klickitat, Kittitas, and Walla Walla counties in Washington, Umatilla, and Morrow counties in Oregon), only 18 tornadoes were recorded from 1950 through March 2001. Of these, 12 tornadoes had maximum wind speeds estimated to be in the range of 18 to 32 m/s (40 to 72 mph), 3 had maximum wind speeds in the range of 33 to 50 m/s (73 to 112 mph), and 3 had maximum wind speeds in the range of 51 to 71 m/s (113 to 157 mph). No deaths or substantial property damage were associated with any of these tornadoes.

Ramsdell and Andrews (1986) report that for the area in which the Hanford Site is located (a 5° block centered at 117.5° west longitude and 47.5° north latitude), the expected path length of a tornado is 7.6 km (4.7 mi). The expected width is 95 m (312 ft), and the expected area is about 1.5 km<sup>2</sup> (0.6 mi<sup>2</sup>). The estimated probability of a tornado striking any point at Hanford, also from Ramsdell and Andrews (1986), is  $9.6 \times 10^{-6}$ /yr. The probabilities of extreme winds associated with tornadoes striking a point can be estimated using the distribution of tornado intensities for the region. These probability estimates are given in Table 4.4.

**Table 4.4.** Estimate of the Probability of Extreme Winds Associated with Tornadoes Striking a Point at Hanford (Ramsdell and Andrews 1986)

Wind Speed		Probability Per Year
(m/s)	(mph)	
28	62	$2.6 \times 10^{-6}$
56	124	$6.5 \times 10^{-7}$
83	186	$1.6 \times 10^{-7}$
111	249	$3.9 \times 10^{-8}$

### 4.3.2 Atmospheric Dispersion

Atmospheric dispersion is defined as the transport and diffusion of gases and particles within the atmosphere. It is a function of wind speed, duration and direction of wind, mixing depth, and the intensity of atmospheric turbulence (wind motions at very small time scales that act to disperse gas and particles rather than transporting them downwind). Atmospheric turbulence is not measured directly at the Hanford Site; instead, the impact of turbulence on atmospheric dispersion is characterized using atmospheric stability. Atmospheric stability describes the thermal stratification or vertical temperature structure of the atmosphere. Generally, six or seven different classes of atmospheric stability are used to describe the atmosphere. These classes range from extremely unstable (when atmospheric turbulence is greatest) to extremely stable (when atmospheric mixing is at a minimum and wind speeds are low). When the atmosphere is unstable, pollutants can rapidly diffuse through a wide volume of the atmosphere. When the atmosphere is stable, pollutants will diffuse much more slowly in a vertical direction. Horizontal dispersion may be limited during stable conditions; however, plumes may also fan out horizontally during stable conditions, particularly when the wind speed is low. Most major pollutant incidents are associated with stable conditions when inversions can trap pollutants near the ground.

Favorable dispersion conditions are most common in the summer when neutral and unstable stratification is present—about 56 percent of the time (Stone et al. 1983). Less favorable dispersion conditions may occur when the wind speed is light and the mixing layer is shallow. These conditions are most common during the winter, when moderately to extremely stable stratification is present, about 66 percent of the time (Stone et al. 1983). Low dispersion conditions also occur periodically for surface and low-level releases in all seasons from about sunset to about an hour after sunrise, as a result of ground-based temperature inversions and shallow mixing layers. Occasionally, extended periods of poor dispersion conditions are associated with stagnant air in the stationary high-pressure systems that occur primarily during the winter months (Stone et al. 1983).

Stone et al. (1972) estimated the probability of extended periods of poor dispersion conditions. The probability of an inversion, once established, persisting more than 12 hr varies from a low of about 10 percent in May and June to a high of about 64 percent in September and October. These probabilities decrease rapidly when the duration of the inversion is more than 12 hr. Table 4.5 summarizes the probabilities associated with extended surface-based inversions.

Many simple dispersion models use the joint frequency distribution of atmospheric stability, wind speed, and wind direction to compute diffusion factors for chronic and acute releases. Joint frequency distributions of atmospheric stability, wind speed, and transport direction for the measurements taken in the 200 Areas at 9.1 m (30 ft) and 60 m (197 ft) are found in Appendix F, Tables F.34 and F.35. The values in the joint frequency distributions represent the percentage of the time that pollutants would initially be transported toward the direction listed<sup>(a)</sup> (for example, S, SSW, SW).

---

(a) The transport direction and the wind direction are different methods of reporting the same basic information. Wind direction and transport direction are always out of phase by 180°.

**Table 4.5.** Percent Probabilities for Extended Periods of Surface-Based Inversions (based on data from Stone et al. 1972)

Months	Inversion Duration		
	12 hr	24 hr	48 hr
	Percent		
January-February	54.0	2.5	0.28
March-April	50.0	<0.1	<0.1
May-June	10.0	<0.1	<0.1
July-August	18.0	<0.1	<0.1
September-October	64.0	0.11	<0.1
November-December	50.0	1.2	0.13

### 4.3.3 Air Quality

The U.S. Environmental Protection Agency (EPA) has issued regulations (40 CFR 50) setting national ambient air quality standards. Individual states have the primary responsibility for assuring that air quality within the state meets the national ambient air quality standards through state implementation plans (SIP) that are approved by EPA. Areas that meet ambient air quality standards are said to be in attainment. Areas that do not meet one or more ambient air quality standards are designated as non-attainment areas. The Hanford Site is in attainment or unclassified with respect to national ambient air quality standards (40 CFR 81.348). Table 4.6 summarizes the relevant air quality standards (federal and supplemental Washington State standards). The nearest non-attainment areas to the Hanford Site are the Wallula area, located approximately 30 km (20 mi) southeast of the site, and Yakima, located approximately 70 km (44 mi) east of the site. Wallula and Yakima are non-attainment areas for PM<sub>10</sub> (40 CFR 81.348).

Ambient air quality standards define levels of air quality that are necessary, with an adequate margin of safety, to protect the public health (primary standards) and the public welfare (secondary standards). Ambient air is that portion of the atmosphere, external to buildings, to which the general public has access (40 CFR 50.1). EPA has issued ambient air quality standards for sulfur oxides (measured as sulfur dioxide), nitrogen dioxide, carbon monoxide, particulates with an aerodynamic diameter less than or equal to a nominal 10 micrometers (PM<sub>10</sub>) and 2.5 micrometers (PM<sub>2.5</sub>), lead, and ozone. The standards specify the maximum pollutant concentrations and frequencies of occurrence that are allowed for specific averaging periods. The averaging periods vary from 1 hr to 1 yr, depending on the pollutant.

**Table 4.6.** Federal and Washington State Ambient Air Quality Standards<sup>(a)</sup> (after Neitzel 2002a)

Pollutant	National Primary	National Secondary	Washington State
<b>Total Suspended Particulates</b>			
Annual geometric mean	NS <sup>(b)</sup>	NS	60 µg/m <sup>3</sup>
24-hr average	NS	NS	150 µg/m <sup>3</sup>
<b>PM<sub>10</sub></b>			
Annual arithmetic mean	50 µg/m <sup>3</sup>	50 µg/m <sup>3</sup>	50 µg/m <sup>3</sup>
24-hr average	150 µg/m <sup>3</sup>	150 µg/m <sup>3</sup>	150 µg/m <sup>3</sup>
<b>PM<sub>2.5</sub></b>			
Annual arithmetic mean	15 µg/m <sup>3</sup>	15 µg/m <sup>3</sup>	NS
24-hr average	65 µg/m <sup>3</sup>	65 µg/m <sup>3</sup>	
<b>Sulfur Dioxide</b>			
Annual average	0.03 ppm (≅80 µg/m <sup>3</sup> )	NS	0.02 ppm (≅50 µg/m <sup>3</sup> )
24-hr average	0.14 ppm (≅365 µg/m <sup>3</sup> )	NS	0.10 ppm (≅260 µg/m <sup>3</sup> )
3-hr average	NS	0.50 ppm (≅1.3 mg/m <sup>3</sup> )	NS
1-hr average	NS	NS	0.40 ppm (≅1.0 mg/m <sup>3</sup> ) <sup>(c)</sup>
<b>Carbon Monoxide</b>			
8-hr average	9 ppm (≅10 mg/m <sup>3</sup> )	9 ppm (≅10 mg/m <sup>3</sup> )	9 ppm (≅10 mg/m <sup>3</sup> )
1-hr average	35 ppm (≅40 mg/m <sup>3</sup> )	35 ppm (≅40 mg/m <sup>3</sup> )	35 ppm (≅40 mg/m <sup>3</sup> )
<b>Ozone</b>			
8-hr average	0.08 ppm (~157 µg/m <sup>3</sup> )	0.08 ppm (~157 µg/m <sup>3</sup> )	NS
1-hr average	0.12 ppm (≅235 µg/m <sup>3</sup> )	0.12 ppm (≅235 µg/m <sup>3</sup> )	0.12 ppm (≅235 µg/m <sup>3</sup> )
<b>Nitrogen Dioxide</b>			
Annual average	0.053 ppm (≅100 µg/m <sup>3</sup> )	0.053 ppm (≅100 µg/m <sup>3</sup> )	0.053 ppm (≅100 µg/m <sup>3</sup> )
<b>Lead</b>			
Quarterly average	1.5 µg/m <sup>3</sup> (d)	1.5 µg/m <sup>3</sup>	1.5 µg/m <sup>3</sup> (e)
<b>Radionuclides</b>			
<b>Fluorides</b>			
12-hr average	NS	NS	3.7 µg/m <sup>3</sup>
24-hr average			2.9 µg/m <sup>3</sup>
7 day average			1.7 µg/m <sup>3</sup>
30 day average			0.84 µg/m <sup>3</sup>
Abbreviations: ppm = parts per million; µg/m <sup>3</sup> = micrograms per cubic meter; mg/m <sup>3</sup> = milligrams per cubic meter.			
(a) Source: 40 CFR 50 and WAC 173-470 – 173-481. Annual standards are never to be exceeded; short-term standards are not to be exceeded more than once per year unless otherwise noted. Particulate pollutants are in micrograms per cubic meter. Gaseous pollutants are in parts per million and equivalent microgram (or milligram) per cubic meter.			
(b) NS = no standard.			
(c) 0.25 ppm not to be exceeded more than twice in any 7 consecutive days (WAC 246-247; 40 CFR 61).			
(d) Emissions of radionuclides to the ambient air from Department of Energy facilities shall not exceed those amounts that would cause any member of the public to receive in any year an effective dose equivalent of 10 mrem/yr (40 CFR 61 Subpart H).			
(e) Emissions of radionuclides in the air shall not cause a maximum accumulated dose equivalent of more than 25 mrem/yr to the whole body or 75 mrem/yr to a critical organ of any member of the public (WAC 173-480) or a TEDE of 10 mrem/yr (40 CFR 61 Subpart H; WAC 267-247), whichever is more stringent. Doses due to radon-220, radon-222, and their respective decay products are excluded from these limits.			

In 1994, DOE and EPA signed the Federal Facility Compliance Agreement for Radionuclides National Emission Standards for Hazardous Air Pollutants (NESHAPs) (EPA 1994). This agreement provides a compliance plan and schedule designed to bring the Hanford Site into compliance with Clean Air Act requirements under 40 CFR 61, Subpart H, for the continuous measurement of emissions from applicable airborne emissions sources. The Hanford Site air emissions are below the regulatory standard of 10 mrem/yr (Poston et al. 2002). Radioactive air emissions are also regulated by Washington State. Hanford Site radionuclide air emissions are below limits set forth by permits issued by the State of Washington (Table 4.6).

State and local governments have the authority to impose standards for ambient air quality that are stricter than the national standards. Washington State has established more stringent standards for sulfur dioxide (WAC 173-474). In addition, Washington State has established standards for total suspended particulates (Washington State Administrative Code [WAC 173-470]), radionuclides (WAC 246-247), and fluorides (WAC 173-481). The Washington State standards for carbon monoxide, nitrogen dioxide, PM<sub>10</sub>, and lead are identical to the national standards. The Hanford Site is in compliance with the Washington State ambient air quality standards (see Table 4.6).

#### **4.3.3.1 Emissions of Non-Radiological Pollutants**

Non-radiological pollutants are emitted mainly from power-generating and chemical-processing facilities located on the Hanford Site. Table 4.7 summarizes the year 2001 airborne emission rates of non-radiological constituents from these facilities. The 100, 400, and 600 Areas have no non-radioactive emission sources of regulatory concern (Poston et al. 2002).

#### **4.3.3.2 Radiological Air Quality**

Air emissions that may contain radioactive constituents are monitored at the Hanford Site. Samples are analyzed for gross alpha and gross beta activity, as well as for selected radionuclides.

Radioactive airborne emissions during 2001 (the most recent year for which data are published) originated in the 100, 200, 300, 400, and 600 Areas. The 100 Area emissions originated from normal evaporation from K Basins (irradiated fuel stored in two water-filled storage basins), the Cold Vacuum Drying Facility in the 100-K Area, and a low-level radiochemistry laboratory. The 200 Area emissions originated from the Plutonium Finishing Plant, T Plant Complex, 222-S Laboratory, tank farms, waste evaporators, and the inactive PUREX Plant. Emissions from the 300 Area originated from the 324 Waste Technology Engineering Laboratory, 325 Applied Chemistry Laboratory, 327 Post-Irradiation Laboratory, and 340 Vault and Tanks. The 400 Area emissions originated from the FFTF, and the Maintenance and Storage Facility. Emissions from the 600 Area originated at the Waste Sampling and Characterization Facility. Releases from this facility are considered as being in the 200 West Area for release and dose-modeling purposes (Poston et al. 2002). A summary of radiological air emissions is provided in Table 4.8.

**Table 4.7.** Non-Radioactive Constituents Emitted to the Atmosphere for the Year 2001  
(Poston et al. 2002)

Constituent	Emission, kg (lb)	
	200 Areas	300 Area
Particulate matter	790 (1,742)	610 (1,345)
Nitrogen oxides	25,000 (55,115)	4500 (9921)
Sulfur oxides	2700 (5952)	35 (77)
Carbon monoxide	17,000 (37,478)	11,000 (24,251)
Lead	0.47 (1.0)	0.0 (0.0)
Volatile organic compounds <sup>(a, b)</sup>	5800 (12,787)	700 (1543)
Ammonia <sup>(c)</sup>	12,000 (26,455)	NE <sup>(d)</sup>
Other toxic air pollutants <sup>(c)</sup>	2600 (5732)	NE

(a) The estimate of volatile organic compound emissions does not include emissions from certain laboratory operations.  
(b) Produced from burning fossil fuels for steam generation and electrical generators, calculated estimates from the 200 East and 200 West Area tank farms, and operation of the 242-A Evaporator and the 200 Areas Effluent Treatment Facility.  
(c) Releases are from the 200 East Area tank farms, 200 West Area tank farms, and operation of the 242-A Evaporator, and the 200 Areas Effluent Treatment Facility.  
(d) NE = no emissions.

The potential air pathway dose from stack emissions to a maximally exposed individual was calculated to be 0.048 mrem/yr, which represents less than 0.5 percent of the EPA standard (Poston et al. 2002).

#### 4.3.4 Background Radiation

For the year 2001, the average external dose rate near the Hanford Site boundary was measured at  $91 \pm 4$  mrem/yr using thermoluminescent dosimeters (Poston et al. 2002). Similarly for communities nearby the site, such as Richland, Pasco, Kennewick, Mattawa, Othello, Basin City, and Benton City, the average dose rate was measured at  $80 \pm 3$  mrem/yr. The average external dose rate measured for distant communities, such as Toppenish and Yakima, was  $72 \pm 2$  mrem/yr. The national average for external radiation dose from naturally occurring sources is about 55 mrem/yr (NCRP 1987), but it varies substantially with elevation and geological conditions. At a given location, the annual variation in external dose rate is on the order of 5 mrem. External radiation is but one part of total effective dose equivalent received from naturally occurring sources. The information presented here are representative of the external dose rate, excluding radon and presence of radionuclides internal to the body. Naturally occurring sources of ionizing radiation include primordial radionuclides, such as potassium-40 and the uranium series; cosmogenic radionuclides, such as carbon-14 and tritium; and cosmic radiation. The radionuclides are present in varying amounts in nearly all media including soil, air, water, food, biota, and humans.

**Table 4.8.** Radionuclides Emitted to the Atmosphere at the Hanford Site, 2001 (Poston et al. 2002)

Radionuclide	Half-Life in Years	Emission, Ci <sup>(a)</sup>				
		100 Areas	200 East Area	200 West Area	300 Area	400 Area
Tritium (as HT) <sup>(b)</sup>	12.3 yr	NM <sup>(c)</sup>	NM	NM	8.9E+01	NM
Tritium (as HTO) <sup>(b)</sup>	12.3 yr	NM	NM	NM	2.4E+02	3.1E-01
Cobalt-60	5.3 yr	3.0E-08	ND <sup>(d)</sup>	ND	ND	NM
Strontium-90	29.1 yr	9.0E-06	1.2E-04 <sup>(e)</sup>	1.4E-04 <sup>(e)</sup>	2.8E-05 <sup>(e)</sup>	NM
Technetium-99	2.13 x 10 <sup>5</sup> yr	NM	NM	NM	ND	NM
Antimony-125	2.77 yr	ND	ND	ND	ND	NM
Iodine-129	1.6 x 10 <sup>7</sup> yr	NM	8.4E-04	NM	NM	NM
Cesium-137	30 yr	2.1E-05	1.2E-04	5.5E-05	3.7E-06	7.5E-06 <sup>(f)</sup>
Uranium-234	2.4 x 10 <sup>5</sup> yr	NM	NM	NM	1.5E-10	NM
Uranium-238	4.5 x 10 <sup>9</sup> yr	NM	NM	NM	3.3E-11	NM
Plutonium-238	87.7 yr	1.5E-07	4.4E-08	4.5E-06	7.7E-09	NM
Plutonium-239, 240	2.4 x 10 <sup>4</sup> yr	1.2E-06	2.1E-06 <sup>(g)</sup>	2.6E-04 <sup>(g)</sup>	1.9E-07 <sup>(g)</sup>	6.9E-07 <sup>(g)</sup>
Plutonium-241	14.4 yr	1.2E-05	3.1E-06	1.4E-04	NM	NM
Americium-241	432 yr	9.5E-07	2.6E-06	4.2E-05	2.5E-08	NM
Americium-243	7380 yr	NM	NM	NM	ND	NM

(a) 1 Ci = 3.7 E+10 Bq;  
(b) HTO = tritiated water vapor; HT = elemental tritium.  
(c) NM = not measured;  
(d) ND = not detected (i.e., either the radionuclide was not detected in any sample during the year or the average of all the measurements for that given radionuclide or type of radioactivity made during the year was below background levels).  
(e) This value includes gross beta release data. Gross beta and unspecified beta results assumed to be strontium-90 for dose calculations.  
(f) This value includes gross alpha release data. Gross alpha and unspecified alpha results assumed to be plutonium-239/240 for dose calculations.  
(g) Analyses were conducted for gross alpha activity, but none was detected. If detected, it would have been assumed to be plutonium-239/240 for dose calculations.

## 4.4 Geologic Resources

Geologic considerations for the Hanford Site include topography and geomorphology, stratigraphy, soil characteristics, and seismicity. This section, which provides an overview of the Hanford Site subsurface environment, focuses primarily on the 200 Area Plateau, located in the center of the site.

### 4.4.1 Topography and Geomorphology

The sites associated with the Hanford Solid Waste Program are located on a broad flat area of the Hanford Site commonly referred to as the Central Plateau. The Central Plateau is within the Pasco Basin, a topographic, structural depression in the southwest corner of the Columbia Basin physiographic subprovince. This subprovince is characterized by generally low-relief hills with deeply carved river



**Table 4.8.** Radionuclides Emitted to the Atmosphere at the Hanford Site, 2001 (Poston et al. 2002)

Radionuclide	Half-Life in Years	Emission, Ci <sup>(a)</sup>				
		100 Areas	200 East Area	200 West Area	300 Area	400 Area
Tritium (as HT) <sup>(b)</sup>	12.3 yr	NM <sup>(c)</sup>	NM	NM	8.9E+01	NM
Tritium (as HTO) <sup>(b)</sup>	12.3 yr	NM	NM	NM	2.4E+02	3.1E-01
Cobalt-60	5.3 yr	3.0E-08	ND <sup>(d)</sup>	ND	ND	NM
Strontium-90	29.1 yr	9.0E-06	1.2E-04 <sup>(e)</sup>	1.4E-04 <sup>(e)</sup>	2.8E-05 <sup>(e)</sup>	NM
Technetium-99	2.13 x 10 <sup>5</sup> yr	NM	NM	NM	ND	NM
Antimony-125	2.77 yr	ND	ND	ND	ND	NM
Iodine-129	1.6 x 10 <sup>7</sup> yr	NM	8.4E-04	NM	NM	NM
Cesium-137	30 yr	2.1E-05	1.2E-04	5.5E-05	3.7E-06	7.5E-06 <sup>(f)</sup>
Uranium-234	2.4 x 10 <sup>5</sup> yr	NM	NM	NM	1.5E-10	NM
Uranium-238	4.5 x 10 <sup>9</sup> yr	NM	NM	NM	3.3E-11	NM
Plutonium-238	87.7 yr	1.5E-07	4.4E-08	4.5E-06	7.7E-09	NM
Plutonium-239, 240	2.4 x 10 <sup>4</sup> yr	1.2E-06	2.1E-06 <sup>(g)</sup>	2.6E-04 <sup>(g)</sup>	1.9E-07 <sup>(g)</sup>	6.9E-07 <sup>(g)</sup>
Plutonium-241	14.4 yr	1.2E-05	3.1E-06	1.4E-04	NM	NM
Americium-241	432 yr	9.5E-07	2.6E-06	4.2E-05	2.5E-08	NM
Americium-243	7380 yr	NM	NM	NM	ND	NM

(a) 1 Ci = 3.7 E+10 Bq;  
(b) HTO = tritiated water vapor; HT = elemental tritium.  
(c) NM = not measured;  
(d) ND = not detected (i.e., either the radionuclide was not detected in any sample during the year or the average of all the measurements for that given radionuclide or type of radioactivity made during the year was below background levels).  
(e) This value includes gross beta release data. Gross beta and unspecified beta results assumed to be strontium-90 for dose calculations.  
(f) This value includes gross alpha release data. Gross alpha and unspecified alpha results assumed to be plutonium-239/240 for dose calculations.  
(g) Analyses were conducted for gross alpha activity, but none was detected. If detected, it would have been assumed to be plutonium-239/240 for dose calculations.

## 4.4 Geologic Resources

Geologic considerations for the Hanford Site include topography and geomorphology, stratigraphy, soil characteristics, and seismicity. This section, which provides an overview of the Hanford Site subsurface environment, focuses primarily on the 200 Area Plateau, located in the center of the site.

### 4.4.1 Topography and Geomorphology

The sites associated with the Hanford Solid Waste Program are located on a broad flat area of the Hanford Site commonly referred to as the Central Plateau. The Central Plateau is within the Pasco Basin, a topographic, structural depression in the southwest corner of the Columbia Basin physiographic subprovince. This subprovince is characterized by generally low-relief hills with deeply carved river

drainage. The elevation of the Central Plateau is approximately 200 m (650 ft) to 230 m (750 ft) above mean sea level. The Plateau decreases in elevation to the north, northwest, and east toward the Columbia River. Plateau escarpments have elevation changes of 15 m (50 ft) to 30 m (100 ft). The Pasco Basin is an area of generally low relief ranging from 120 m (390 ft) above mean sea level at the Columbia River level, to 230 m (750 ft) above mean sea level in the 200 East Area. The Pasco Basin is bounded on the north by the Saddle Mountains; on the west by Umtanum Ridge, Yakima Ridge, and the Rattlesnake Hills; on the south by Rattlesnake Mountain and the Rattlesnake Hills; and on the east by the Palouse Slope. The Pasco Basin is shown in Figure 4.9.

Surface topography at the Hanford Site is the result of the uplift of anticlinal ridges, Pleistocene cataclysmic flooding, Holocene eolian activity, and landslides (Delaney et al. 1991). Uplift of the ridges began in the Miocene Epoch (24 to 5 million years ago), concurrent with the eruption of the flood basalts. Cataclysmic flooding occurred when glacial ice dams in western Montana and northern Idaho were breached, allowing large volumes of water to spill across eastern and central Washington State.

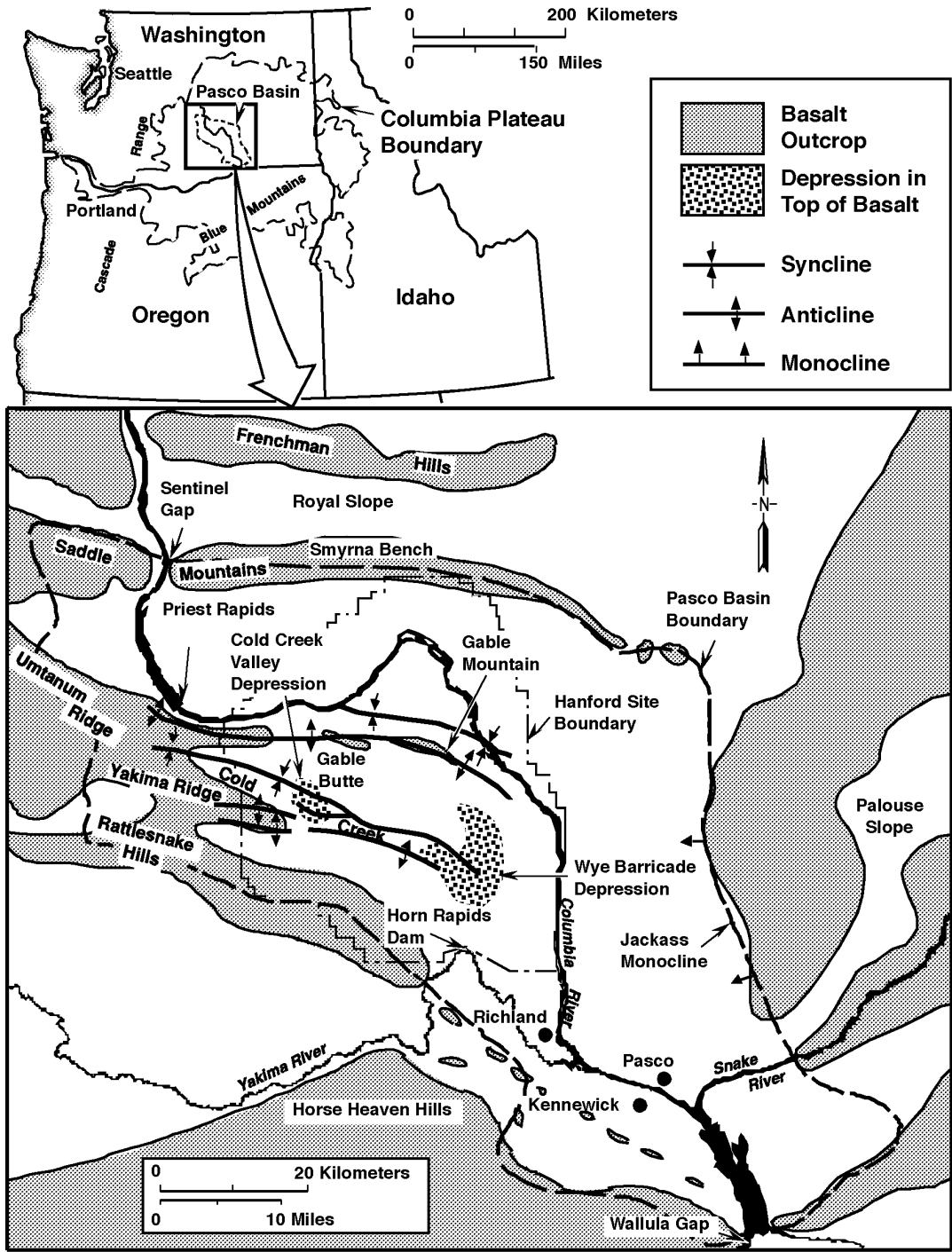
Much of the landscape in the path of the floodwater was stripped of sediments and basalt bedrock was scoured, forming scabland topography (elevated areas underlain by flat-lying basalt flows that generally exhibit deep, dry channels scoured into the surface). The last major flood occurred approximately 13,000 years ago during the late Pleistocene Epoch. Since then, winds have locally reworked the flood sediments, depositing dune sands in the lower elevations and loess (windblown silt) around the margins of the Pasco Basin. Anchoring vegetation has stabilized many sand dunes. Where human activity or natural events have disturbed this vegetation, dunes have been reactivated. For example, dunes have been reactivated by the removal of vegetation as a consequence of a large wildfire that occurred on the Hanford site in July 2000.

The 200 Areas are situated between the Gable Mountain anticline and the Cold Creek syncline. The Gable Mountain anticline is of particular importance to the groundwater flow. Portions of this anticline have been uplifted to a point where basalt is above the current water table. These basalts have a low hydraulic conductivity and act as a barrier to horizontal groundwater flow in the unconfined aquifer.

#### **4.4.2 Stratigraphy**

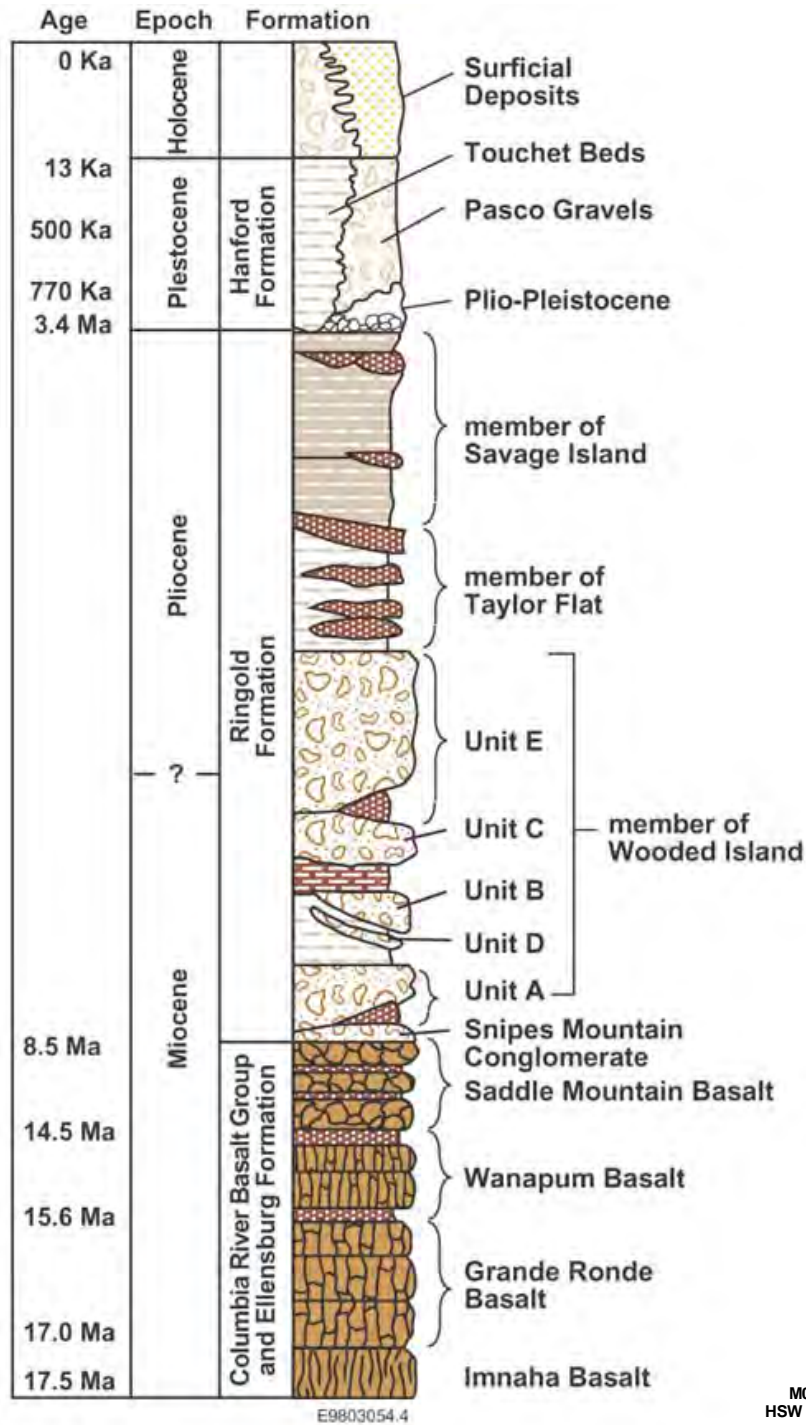
The stratigraphy of the Hanford Site consists of Miocene-age and younger rocks. Older Cenozoic sedimentary and volcanoclastic rocks underlying the Miocene rocks are not exposed at the surface. Figure 4.10 summarizes the Hanford Site stratigraphy. A generalized west to east cross-section depicting site structure and topography is shown as Figure 4.11.

Over 100 basalt flows of the Columbia River Basalt Group, with a total thickness exceeding 3000 m (10,000 ft), lie beneath the Hanford Site. Interbedded between many of these basalt flows are sedimentary rocks of the Ellensburg Formation, a series of sand, gravel, or silt layers that were deposited by the ancestral Columbia River system. Sediments up to 230 m (750 ft) thick overlie the Columbia River Basalt Group, and include the Ringold and Hanford formations. Thin, laterally discontinuous

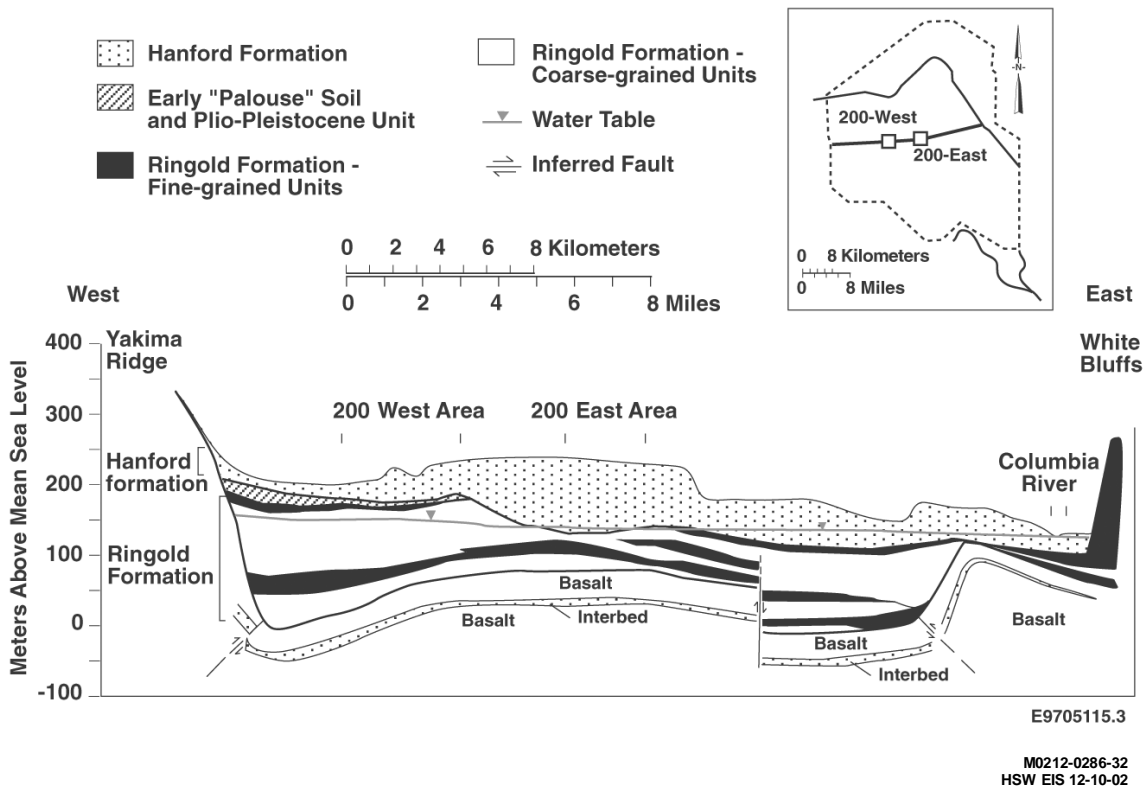


S9509085.4  
M0212-0286-30  
HSW EIS 12-10-02

**Figure 4.9.** Geographic Setting and General Structural Geology of the Pasco Basin and Hanford Site (Bergstrom et al. 1983)



**Figure 4.10.** Stratigraphic Column for the Hanford Site (Reidel et al. 1992; Ka = thousand years; Ma = million years)



**Figure 4.11.** Generalized West to East Cross-Section of the Hanford Site Structure and Topography (DOE-RL 1999)

sedimentary deposits, referred to as the Plio-Pleistocene unit, pre-Missoula gravels, and early Palouse soil, locally separate the Ringold Formation from the overlying Hanford formation.

The Ringold Formation consists of siltstones, sandstones, and conglomerates deposited by the ancestral Columbia River system between 8 and 3 million years ago. The Ringold Formation reaches 180 m (600 ft) in thickness in the Cold Creek syncline south of the 200 West Area but thins and pinches out to the north. It is subdivided into five gravel layers referred to as Units A, B, C, D, and E that are separated by finer-grained units, including the lower mud (Figure 4.10).

The Hanford formation was deposited between 2 million years and 10,000 years ago by cataclysmic flooding from glacial Lake Missoula. The Hanford formation consists of pebble to boulder gravel, fine to coarse-grained sand, and silt, and is thickest (up to 65 m [210 ft]) under the 200 Areas. Gravel dominates the Hanford formation in the northern part of the area, while sand-dominated material is found most commonly in the central to southern parts. Holocene surficial deposits consisting of silt, sand, and gravel form a thin (less than 10-m [33-ft]) surface layer across much of the Hanford Site. Eolian (wind) and alluvial processes deposited these surficial materials.

The geology in the 200 West Area is notably different from the 200 East Area, considering a distance of only 6 km (4 mi) separates them. One of the most complete suprabasalt stratigraphic sections on the Hanford Site containing most Ringold units, the Plio-Pleistocene unit, early Palouse soil, and the Hanford formation, is present in the 200 West Area.

In the 200 East Area, most of the Ringold Formation units are present in the southern part but have been eroded in a complex pattern to the north. On the north side of the 200 East Area, the Hanford formation rests directly on the basalt, and no Ringold sediments are present. Erosion by the ancestral Columbia River and catastrophic flooding are believed to have removed the Ringold Formation from this area. A unit of questionable origin locally overlies basalt within the B-BX-BY Waste Management Area (Schalla et al. 2000). This unit, referred to informally as H/PP deposits, may be equivalent or partially equivalent to the Plio-Pleistocene unit or it may represent the earliest ice-age flood deposits overlain by a locally thick sequence of fine-grained non-flood deposits.

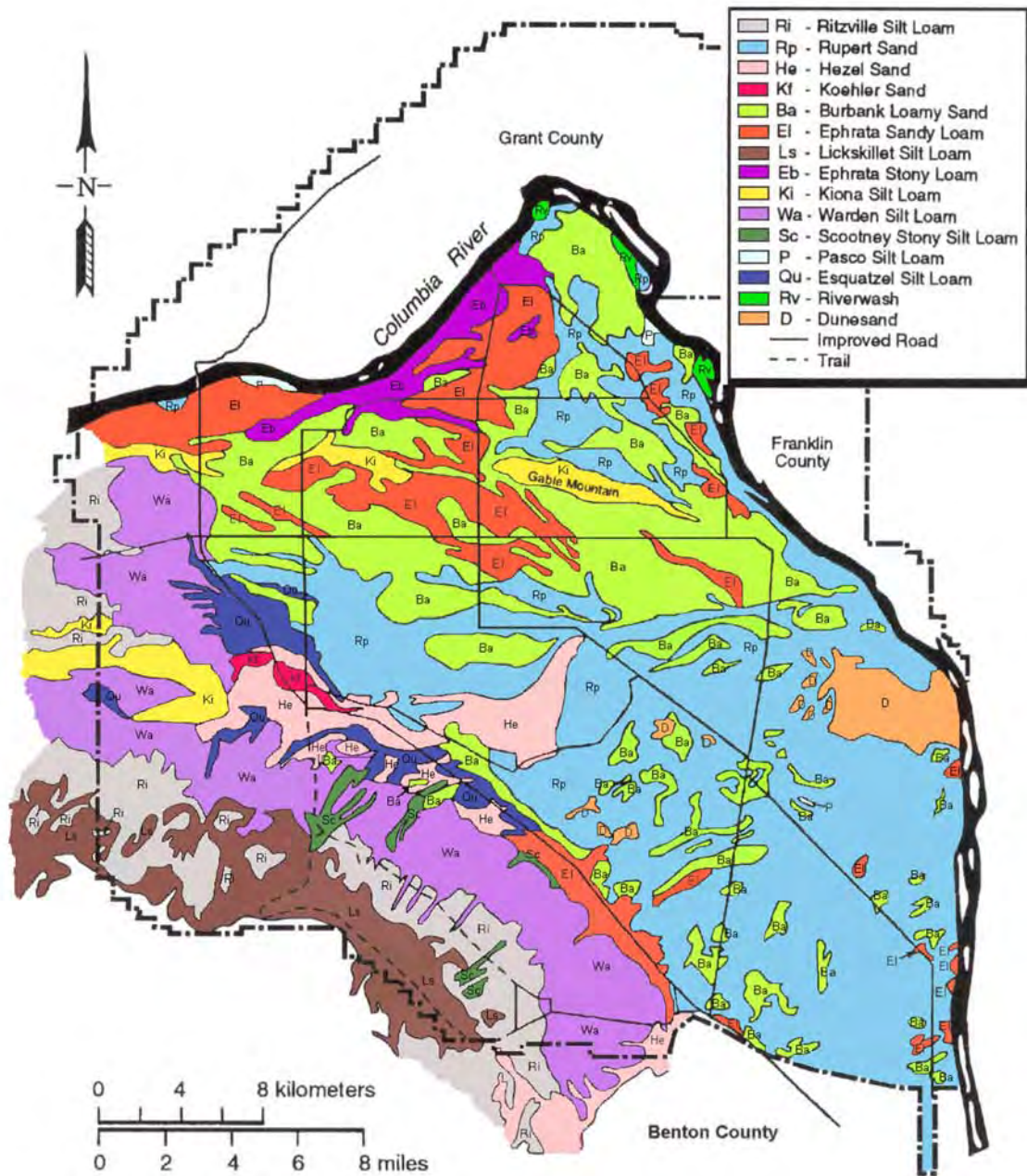
#### **4.4.3 Soils**

Hajek (1966) describes 15 different soil types on the Hanford Site, varying from sand to silty and sandy loam. These soils are shown in Figure 4.12 and briefly described in Table 4.9.

The majority of the 200 West Area soils are Rupert Sand; the remaining third is Burbank Loamy Sand. The 200 East Area soils are composed of Ephrata Sandy Loam, Rupert Sand, and Burbank Loamy Sand.

#### **4.4.4 Seismicity**

The Hanford Site lies in an area of relatively low seismic activity. Figure 4.13 shows the locations of known earthquakes that occurred in the Columbia Plateau between 1850 and 1969 with a Modified Mercalli Intensity (MMI) of V or more and at Richter magnitude 4.0 or more. The largest earthquake that may have occurred in the eastern Washington area shown in Figure 4.13 happened in 1872, with MMI IX and estimated magnitude near 7.0, but its location has been variously estimated from Wenatchee to British Columbia. Figure 4.14 shows the locations of all earthquakes that occurred from 1969 to 2000 at Richter magnitudes of 3.0 or more. The largest known earthquake in the Columbia Plateau occurred in 1936 near Milton-Freewater, Oregon. This earthquake had a Richter magnitude of approximately 6.0 and a maximum MMI of VII, and was followed by a number of aftershocks indicating a northeast-trending fault plane. Other earthquakes with Richter magnitudes  $\geq 5$  or MMI of VI occurred along the boundaries of the Columbia Plateau in a cluster near Lake Chelan in 1872 extending into the northern Cascade Range, in northern Idaho and Washington, and along the boundary between the western Columbia Plateau and the Cascade Range. Three MMI VI earthquakes have occurred within the Columbia Plateau, including one event in the Milton-Freewater, Oregon, region in 1921; one near Yakima, Washington, in 1892; and one near Umatilla, Oregon, in 1893. In the central portion of the Columbia Plateau, the largest earthquakes near the Hanford Site are two earthquakes that occurred in 1918 and 1973. These two events were magnitude 4.4 and intensity V, and were located north of the Hanford Site near Othello.



M0212-0286-33  
 HSW EIS 12-10-02

**Figure 4.12.** Soil Map of the Hanford Site (after Hajak 1966). (See Table 4.9 for description of soil types.)



**Table 4.9.** Soil Types on the Hanford Site (after Hajek 1966)

<b>Name (symbol)</b>	<b>Description</b>
Ritzville Silt Loam (Ri)	Dark-colored silt loam soils midway up the slopes of the Rattlesnake Hills. Developed under bunch grass from silty wind-laid deposits mixed with small amounts of volcanic ash. Characteristically greater than 150 cm (60 in.) deep, but bedrock may occur between 75 and 150 cm (30 and 60 in.).
Rupert Sand (Rp)	One of the most extensive soils on the Hanford Site. Brown-to grayish-brown coarse sand grading to dark grayish-brown at 90 cm (35 in.). Developed under grass, sagebrush, and hopsage in coarse sandy alluvial deposits that were mantled by wind-blown sand. Hummocky terraces and dune-like ridges.
Hezel Sand (He)	Similar to Rupert sands; however, laminated grayish-brown strongly calcareous silt loam subsoil is usually encountered within 100 cm (39 in.) of the surface. Surface soil is very dark brown and was formed in wind-blown sands that mantled lake-laid sediments.
Koehler Sand (Kf)	Similar to other sandy soils on the Hanford Site. Developed in a wind-blown sand mantle. Differs from other sands in the sand mantles a lime-silica cemented Hardpan layer. Very dark grayish-brown surface layer is somewhat darker than Rupert. Calcareous subsoil is usually dark grayish-brown at about 45 cm (18 in.).
Burbank Loamy Sand (Ba)	Dark-colored, coarse-textured soil underlain by gravel. Surface soil is usually about 40 cm (16 in.) thick but can be 75 cm (30 in.) thick. Gravel content of subsoil ranges from 20 percent to 80 percent.
Ephrata Sandy Loam (El)	Surface is dark colored and subsoil is dark grayish-brown medium-textured soil underlain by gravelly material that may continue for many feet. Level topography.
Licksillet Silt Loam (Ls)	Occupies ridge slopes of Rattlesnake Hills and slopes greater than 765 m (2509 ft) elevation. Similar to Kiona series except the surface soils are darker. Shallow over basalt bedrock, with numerous basalt fragments throughout the profile.
Ephrata Stony Loam (Eb)	Similar to Ephrata sandy loam. Differs in that many large hummocky ridges are made up of debris released from melting glaciers. Areas between hummocks contain many boulders several feet in diameter.
Kiona Silt Loam (Ki)	Occupies steep slopes and ridges. Surface soil is very dark grayish-brown and about 10 cm (4 in.) thick. Dark-brown subsoil contains basalt fragments 30 cm (12 in.) and larger in diameter. Many basalt fragments are found in surface layer. Basalt rock outcrops present. A shallow stony soil normally occurring in association with Ritzville and Warden soils.
Warden Silt Loam (Wa)	Dark grayish-brown soil with a surface layer usually 23 cm (9 in.) thick. Silt loam subsoil becomes strongly calcareous at about 50 cm (20 in.) and becomes lighter colored. Granitic boulders are found in many areas. Usually greater than 150 cm (60 in.) deep.

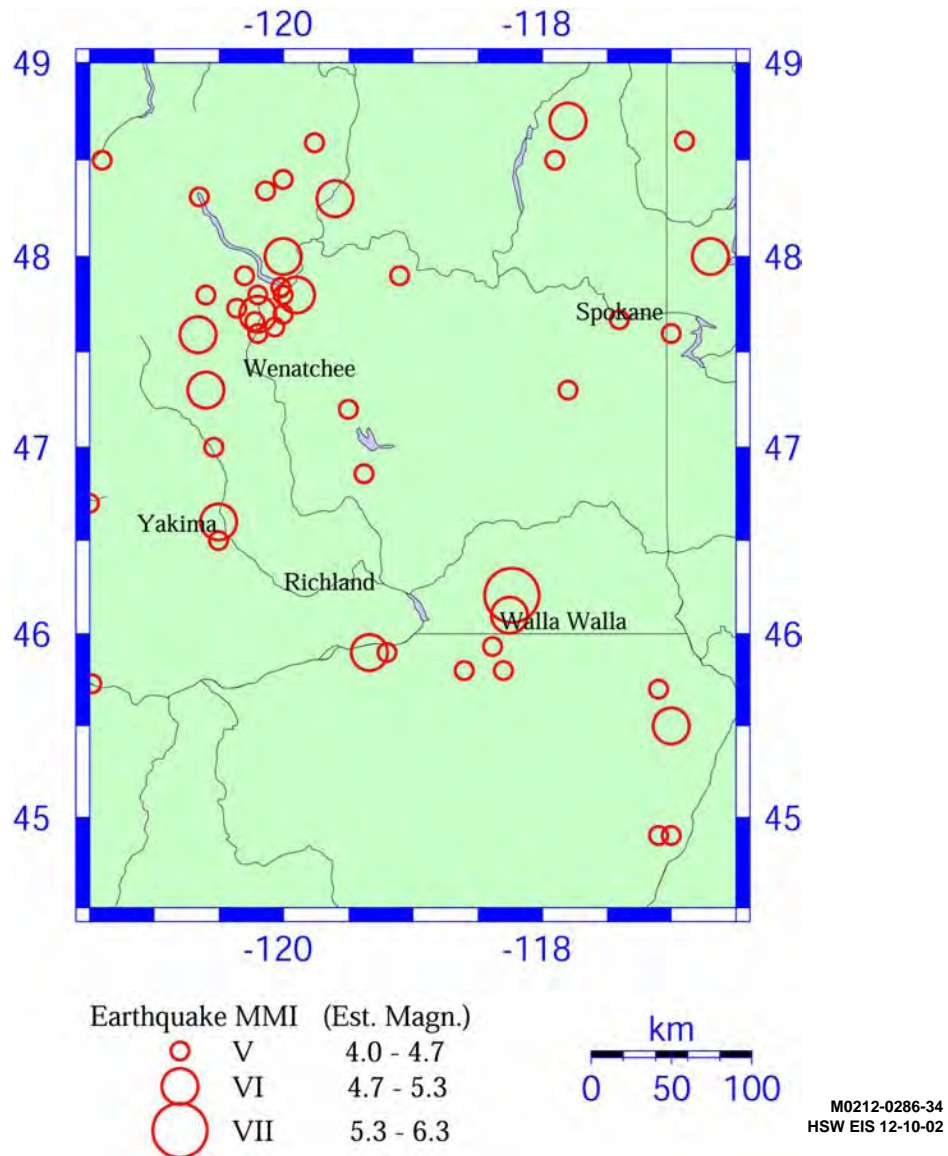


**Table 4.9. (contd)**

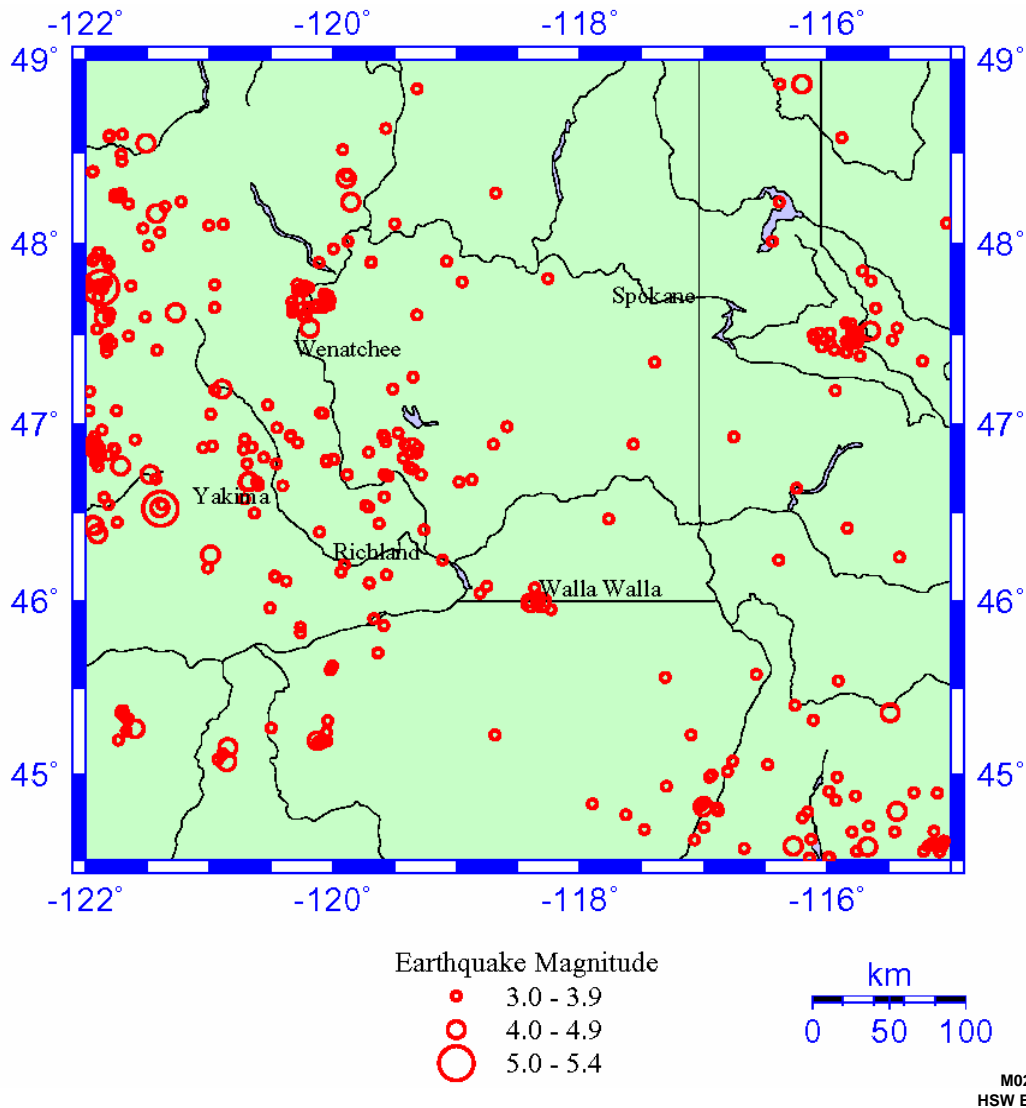
Name (symbol)	Description
Scootney Stony Silt Loam (Sc)	Developed along the north slope of Rattlesnake Hills; usually confined to floors of narrow draws or small fan-shaped areas where draws open onto plains. Severely eroded with numerous basaltic boulders and fragments exposed. Surface soil is usually dark grayish-brown grading to grayish-brown in the subsoil.
Pasco Silt Loam (P)	Poorly drained very dark grayish-brown soil formed in recent alluvial material. Subsoil is variable, consisting of stratified layers. Only small areas found on the Hanford Site, located in low areas adjacent to the Columbia River.
Esquatzel Silt Loam (Qu)	Deep dark-brown soil formed in recent alluvium derived from loess and lake sediments. Subsoil grades to dark grayish-brown in many areas, but color and texture of the subsoil are variable because of the stratified nature of the alluvial deposits.
Riverwash (Rv)	Wet, periodically flooded areas of sand, gravel, and boulder deposits that make up overflowed islands in the Columbia River and adjacent land.
Dunesand (D)	Miscellaneous land type that consists of hills or ridges of sand-sized particles drifted and piled up by wind. Are either actively shifted or so recently fixed or stabilized that no soil horizons have developed.

In addition, earthquake swarms of small magnitudes that are not associated with mapped faults occur on and around the Hanford Site. The region north and east of the Hanford Site is a region of concentrated earthquake swarm activity, but earthquake swarms have also occurred in several locations within the Hanford Site. The frequency of earthquakes in a swarm tends to gradually increase and decay with no one outstanding large event within the sequence. Roughly 90 percent of the earthquakes in swarms have Richter magnitudes of 2 or less. These earthquake swarms generally occur at shallow depths, with 75 percent of the events located at depths <4 km (<2.5 mi). Each earthquake swarm typically lasts several weeks to months, consists of several to 100 or more earthquakes, and the locations are clustered in an area 5 to 10 km (3 to 6.2 mi) in lateral dimension.

Estimates for the earthquake potential of structures and zones in the central Columbia Plateau have been developed during the licensing of nuclear power plants at the Hanford Site. In reviewing the operating license application for the Washington Public Power Supply System (now Energy Northwest) Columbia Generating Station (formerly WNP-2), the U.S. Nuclear Regulatory Commission (NRC) concluded that four earthquake sources should be considered for seismic design: the Rattlesnake-Wallula alignment, Gable Mountain, a floating earthquake in the tectonic province, and a swarm area (NRC 1982).



**Figure 4.13.** Historical Seismicity of the Columbia Plateau and Surrounding Areas. All earthquakes between 1850 and March 20, 1969, with a Modified Mercalli Intensity of V or larger or a Richter magnitude of 4.0 or larger, are shown (Rohay 1989). The magnitude ranges correspond to the original intensity estimated historically. Symbol sizes are only approximately related to those used in Figure 4.14. The uncertain location of the 1872 earthquake is not shown.



**Figure 4.14.** Seismicity of the Columbia Plateau and Surrounding Areas as Measured by Seismographs. All earthquakes from 3/20/1969 to 12/31/2000 with Richter magnitude 3 or larger are shown. Data sources: Council of the National Seismic System (CNSS 2001), University of Washington Geophysics Program (UWGP 2001).

For the Rattlesnake-Wallula alignment, which passes along the southwest boundary of the Hanford Site, the NRC estimated a maximum Richter magnitude of 6.5; for Gable Mountain, an east-west structure that passes through the northern portion of the Hanford Site, a maximum Richter magnitude of 5.0 was estimated. These estimates were based upon the inferred sense of slip, the fault length, and the fault area. The floating earthquake for the tectonic province was developed from the largest event located in the Columbia Plateau, the Richter magnitude 5.75 Milton-Freewater earthquake. The maximum swarm earthquake for the purpose of Columbia Generating Station seismic design was a Richter magnitude 4.0 event, based on the maximum swarm earthquake in 1973. (The NRC concluded the actual magnitude of this event was smaller than estimated previously.)

Probabilistic seismic hazard analyses have been used to determine the seismic ground motions expected from multiple earthquake sources, and these are used to design or evaluate facilities on the Hanford Site. The most recent Hanford Site-specific hazard analysis (Tallman 1994, 1996) estimated that 0.10 g (1 g is the acceleration of gravity) horizontal acceleration would be experienced on average every 500 yr (or with a 10 percent chance every 50 yr). This study also estimated that 0.2 g would be experienced on average every 2500 yr (or with a 2 percent chance in 50 yr). These estimates are in approximate agreement with the results of national seismic hazard maps produced by the U.S. Geological Survey (Frankel et al. 1996).

The Pacific Northwest National Laboratory (PNNL) and the University of Washington (UW) operate a 40-station seismic monitoring network in eastern Washington, which has been used to determine the locations and magnitudes of earthquakes since 1969. In addition, PNNL operates a network of five strong motion accelerometers near Hanford facilities to measure ground motion levels from larger earthquakes (Hartshorn et al. 2001).

## **4.5 Hydrology**

Hydrology considerations at the Hanford Site include surface water, the vadose zone, and groundwater. The vadose zone is the unsaturated or partially saturated region between ground surface and the saturated zone. Water in the vadose zone is called soil moisture. Groundwater refers to water within the saturated zone. Permeable saturated units in the subsurface are called aquifers.

### **4.5.1 Surface Water**

Surface water at Hanford includes the Columbia River, Columbia riverbank seepage, springs, and ponds. Intermittent surface streams, such as Cold Creek, may also contain water after large precipitation or snowmelt events. In addition, the Yakima River flows near a short section of the southern boundary of the Hanford Site (Figure 4.15).

#### **4.5.1.1 Columbia River**

In terms of total flow, the Columbia River is the second largest river in the contiguous United States and is the dominant surface-water body on the Hanford Site. The original selection of the Hanford Site for plutonium production and processing was based, in part, on the abundant water provided by the Columbia River.

Originating in the mountains of eastern British Columbia, Canada, the Columbia River drains an area of about 680,000 km<sup>2</sup> (260,000 mi<sup>2</sup>) en route to the Pacific Ocean. The primary uses of the Columbia River include the production of hydroelectric power, irrigation of cropland in the Columbia Basin, and transportation of materials by barge. Many communities located on the Columbia River rely on the river as their source of drinking water (see Section 4.8.9). The Columbia River is also used as a source of drinking water and industrial water for several Hanford Site facilities (Dirkes 1993). In addition, the Columbia River is used extensively for recreation that includes fishing, bird hunting, boating, sail boarding, water skiing, diving, and swimming.

Probabilistic seismic hazard analyses have been used to determine the seismic ground motions expected from multiple earthquake sources, and these are used to design or evaluate facilities on the Hanford Site. The most recent Hanford Site-specific hazard analysis (Tallman 1994, 1996) estimated that 0.10 g (1 g is the acceleration of gravity) horizontal acceleration would be experienced on average every 500 yr (or with a 10 percent chance every 50 yr). This study also estimated that 0.2 g would be experienced on average every 2500 yr (or with a 2 percent chance in 50 yr). These estimates are in approximate agreement with the results of national seismic hazard maps produced by the U.S. Geological Survey (Frankel et al. 1996).

The Pacific Northwest National Laboratory (PNNL) and the University of Washington (UW) operate a 40-station seismic monitoring network in eastern Washington, which has been used to determine the locations and magnitudes of earthquakes since 1969. In addition, PNNL operates a network of five strong motion accelerometers near Hanford facilities to measure ground motion levels from larger earthquakes (Hartshorn et al. 2001).

## **4.5 Hydrology**

Hydrology considerations at the Hanford Site include surface water, the vadose zone, and groundwater. The vadose zone is the unsaturated or partially saturated region between ground surface and the saturated zone. Water in the vadose zone is called soil moisture. Groundwater refers to water within the saturated zone. Permeable saturated units in the subsurface are called aquifers.

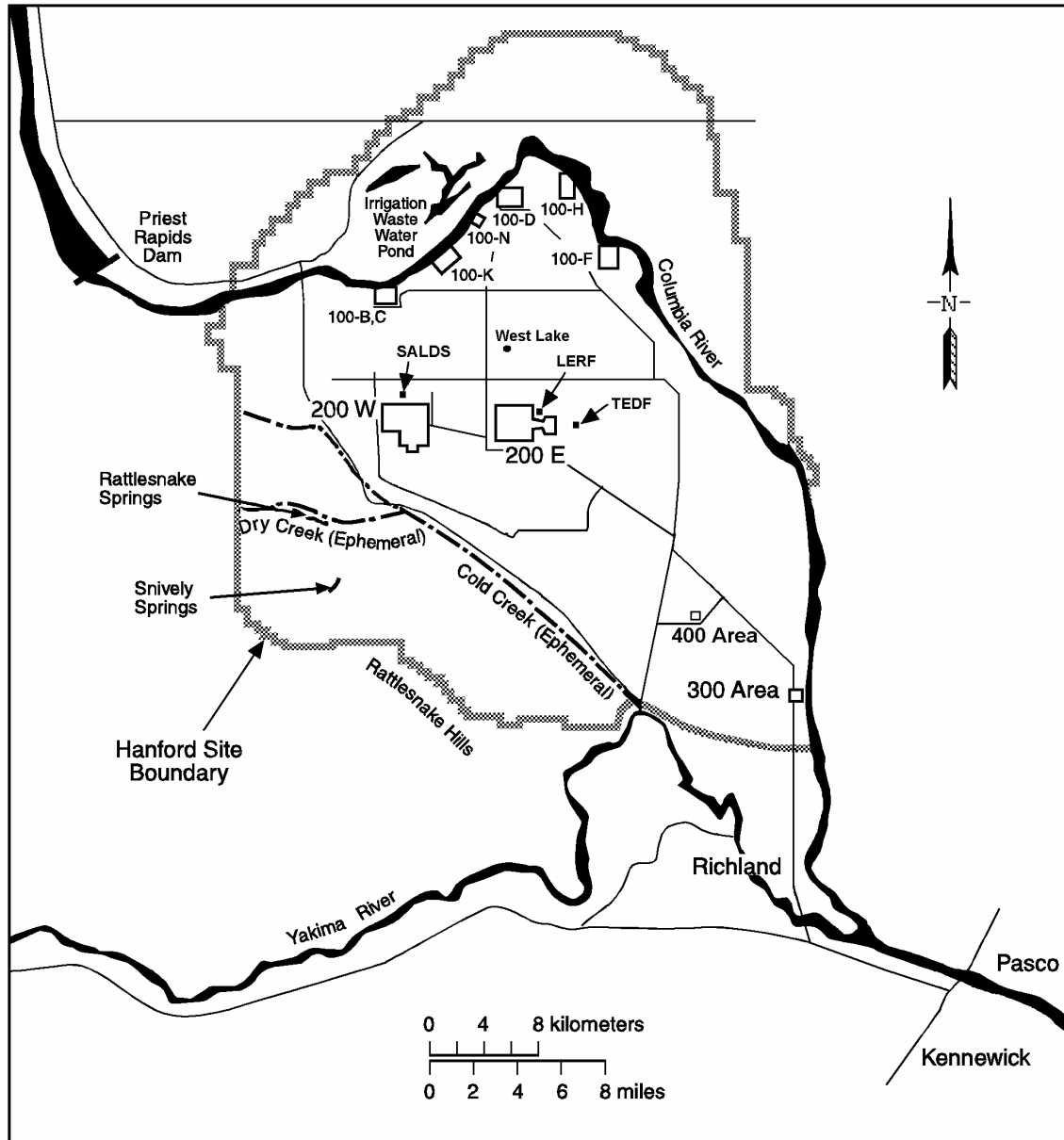
### **4.5.1 Surface Water**

Surface water at Hanford includes the Columbia River, Columbia riverbank seepage, springs, and ponds. Intermittent surface streams, such as Cold Creek, may also contain water after large precipitation or snowmelt events. In addition, the Yakima River flows near a short section of the southern boundary of the Hanford Site (Figure 4.15).

#### **4.5.1.1 Columbia River**

In terms of total flow, the Columbia River is the second largest river in the contiguous United States and is the dominant surface-water body on the Hanford Site. The original selection of the Hanford Site for plutonium production and processing was based, in part, on the abundant water provided by the Columbia River.

Originating in the mountains of eastern British Columbia, Canada, the Columbia River drains an area of about 680,000 km<sup>2</sup> (260,000 mi<sup>2</sup>) en route to the Pacific Ocean. The primary uses of the Columbia River include the production of hydroelectric power, irrigation of cropland in the Columbia Basin, and transportation of materials by barge. Many communities located on the Columbia River rely on the river as their source of drinking water (see Section 4.8.9). The Columbia River is also used as a source of drinking water and industrial water for several Hanford Site facilities (Dirkes 1993). In addition, the Columbia River is used extensively for recreation that includes fishing, bird hunting, boating, sail boarding, water skiing, diving, and swimming.



LERF – Liquid Effluent Retention Facility  
 SALDS – State-Approved Land Disposal Structure  
 TEDF – Treated Effluent Disposal Facility

S9508017.4

M0212-0286-36  
 HSW EIS 12-10-02

**Figure 4.15.** Surface Water Features Including Rivers, Ponds, Major Springs, Ephemeral Streams, and Artificial Ponds on the Hanford Site (after Neitzel 2002a)

#### **4.5.1.2 Springs and Streams**

Rattlesnake Springs and Snively Springs, two small spring-fed streams on the Fitzner/Eberhardt Arid Lands Ecology Reserve (ALE), are the only naturally occurring streams on the Hanford Site. Rattlesnake Springs, located 10 km (6 mi) west of the 200 West Area, forms a small surface stream that flows for approximately 2.5 km (1.6 mi) before it disappears into the ground as a result of seepage. Base flow of this stream is about 0.01 m<sup>3</sup>/s (0.4 ft<sup>3</sup>/s) (Cushing and Wolf 1982). Snively Springs is located to the west and at a higher elevation than Rattlesnake Springs.

Cold Creek and its tributary, Dry Creek, are ephemeral streams within the Yakima River drainage system in the southwestern portion of the Hanford Site. These streams drain areas to the west of the Hanford Site and cross the southwestern part of the site toward the Yakima River. When it occurs, surface flow infiltrates rapidly and disappears into the surface sediments in the western part of the site.

#### **4.5.1.3 Columbia Riverbank Seepage**

The seepage of groundwater into the Columbia River has been known to occur for many years. Riverbank seeps were documented along the Hanford Reach long before Hanford operations began during the Second World War (Jenkins 1922). Seepage occurs below the river surface and also on the exposed riverbank, particularly noticeable at low-river stage. The seeps flow intermittently, apparently influenced primarily by changes in river level. Groundwater contaminants attributed to Hanford operations reach the Columbia River through these seeps.

#### **4.5.1.4 Onsite Ponds and Artificial Water Bodies**

West Lake is the only naturally occurring pool on the Hanford Site. West Lake is several hectares in size and is located approximately 8 km (5 mi) northeast of the 200 West Area and about 3 km (2 mi) north of the 200 East Area. It is situated in a topographically low-lying area and is sustained by groundwater inflow resulting from an intersection with the groundwater table. Water levels of West Lake fluctuate with water table elevation, which is influenced by wastewater discharge in the 200 Areas. The water level and size of the lake has been decreasing over the past several years because of reduced wastewater discharge. West Lake water quality samplings demonstrate elevated dissolved solids and nitrates. Total dissolved solids are approximately 15,000 mg/L, and pH is over 9. Nitrate concentrations are about 1.8 mg/L and ammonia concentrations are about 2.6 mg/L (Neitzel 2002a). Evaporation has also led to relatively high levels of uranium due to concentration of natural sources (Poston et al. 1991).

The Nature Conservancy (Hall 1998) has documented the existence of several naturally occurring vernal ponds near Gable Mountain and Gable Butte. These ponds appear to occur where a depression is present in a relatively shallow buried basalt surface. Water collects within the depression over the winter, resulting in a shallow pond that dries during the summer months. The formation of these ponds in any particular year depends on the amount and temporal distribution of precipitation and snowmelt events. The vernal ponds ranged in size from about 6.1 m x 6.1 m to 45.73 m x 30.5 m (20 ft x 20 ft to 150 ft x 100 ft), and were found in three clusters. Approximately ten vernal ponds were documented at the

eastern end of Umtanum Ridge, six or seven were observed in the central part of Gable Butte, and three were found at the eastern end of Gable Mountain.

The 200 Area Treated Effluent Disposal Facility (TEDF) consists of two man-made disposal ponds. These ponds are each 2 ha (5 ac) in size and receive industrial wastewater permitted in accordance with the State Waste Discharge Permit Program (WAC 173-216). The treated effluent percolates into the ground from the disposal ponds.

The Liquid Effluent Retention Facility (LERF) is a wastewater holding facility consisting of three surface impoundments with a total capacity of 29.5 million L (7.8 million gal) each. The LERF provides storage until the waste is transferred to the ETF for final treatment. These ponds are equipped with double liners, a leak detection system, and floating covers (Poston et al. 2002). The LERF also includes piping and pumping systems, utilities, and a basin operations structure. Aqueous waste from the LERF is transferred to the 200 Area Effluent Treatment Facility (ETF) via pipelines.

The State-Approved Land Disposal Structure (SALDS) is located north of the 200 West Area. The SALDS is a Washington State permitted facility containing drain fields where tritium-bearing wastewater discharge is authorized as per the permit.

#### **4.5.1.5 Floodplains and Runoff**

No floodplains are found in the 200 Areas. Although floods in Cold Creek and Dry Creek have occurred historically, no historic flood events have been observed in the 200 Areas. The flooding of Cold Creek and Dry Creek infiltrated into the permeable sediments before reaching the 200 Areas.

Natural runoff generated onsite or from offsite up-gradient sources is not known to occur in the 200 Areas. Measurable runoff occurs during brief periods in two locations, Cold Creek Valley and Dry Creek Valley west and southwest of the 200 West Area (Newcomb et al. 1972). This surface runoff either infiltrates into the valley floor or evaporates. During periods of unusually rapid snowmelt or heavy rainfall, surface runoff extends beyond Rattlesnake Springs in the upper part of Dry Creek. However, this runoff quickly infiltrates into the alluvial sediments of Cold Creek Valley.

Evaluation of flood potential is conducted in part through the concept of the probable maximum flood, which is determined from the upper limit of precipitation falling on a drainage area and other hydrologic factors, such as antecedent moisture conditions, snowmelt, and tributary conditions that could result in maximum runoff. The probable maximum flood for the Columbia River downstream of Priest Rapids Dam has been calculated to be 40,000 m<sup>3</sup>/s (1.4 million ft<sup>3</sup>/s) and is greater than the 500-year flood. This flood would inundate parts of the 100 Areas located adjacent to the Columbia River, but the Central Plateau region of the Hanford Site would remain unaffected (DOE 1986).

In 1980, a flood risk analysis of Cold Creek, an ephemeral stream within the Yakima River drainage system, was conducted as part of the characterization of a basaltic geologic repository for high-level radioactive waste. Such design work is usually done according to the criteria of Standard Project Flood or probable maximum flood, rather than the worst-case or 100-year flood scenario. Therefore, in lieu of



100- and 500-year floodplain studies, a probable maximum flood evaluation was performed (Skaggs and Walters 1981). The probable maximum flood discharge rate for the lower Cold Creek Valley was 2265 m<sup>3</sup>/s (80,000 ft<sup>3</sup>/s) compared to 564 m<sup>3</sup>/s (19,900 ft<sup>3</sup>/s) for the 100-year flood. Modeling indicated that State Route (SR) 240 along the Hanford Site's southwestern and western areas would not be usable (Figure 4.16). Water from a probable maximum flood could potentially reach the southwest corner of the 200 West Area, but not the waste management areas.

#### **4.5.2 Hanford Site Vadose Zone**

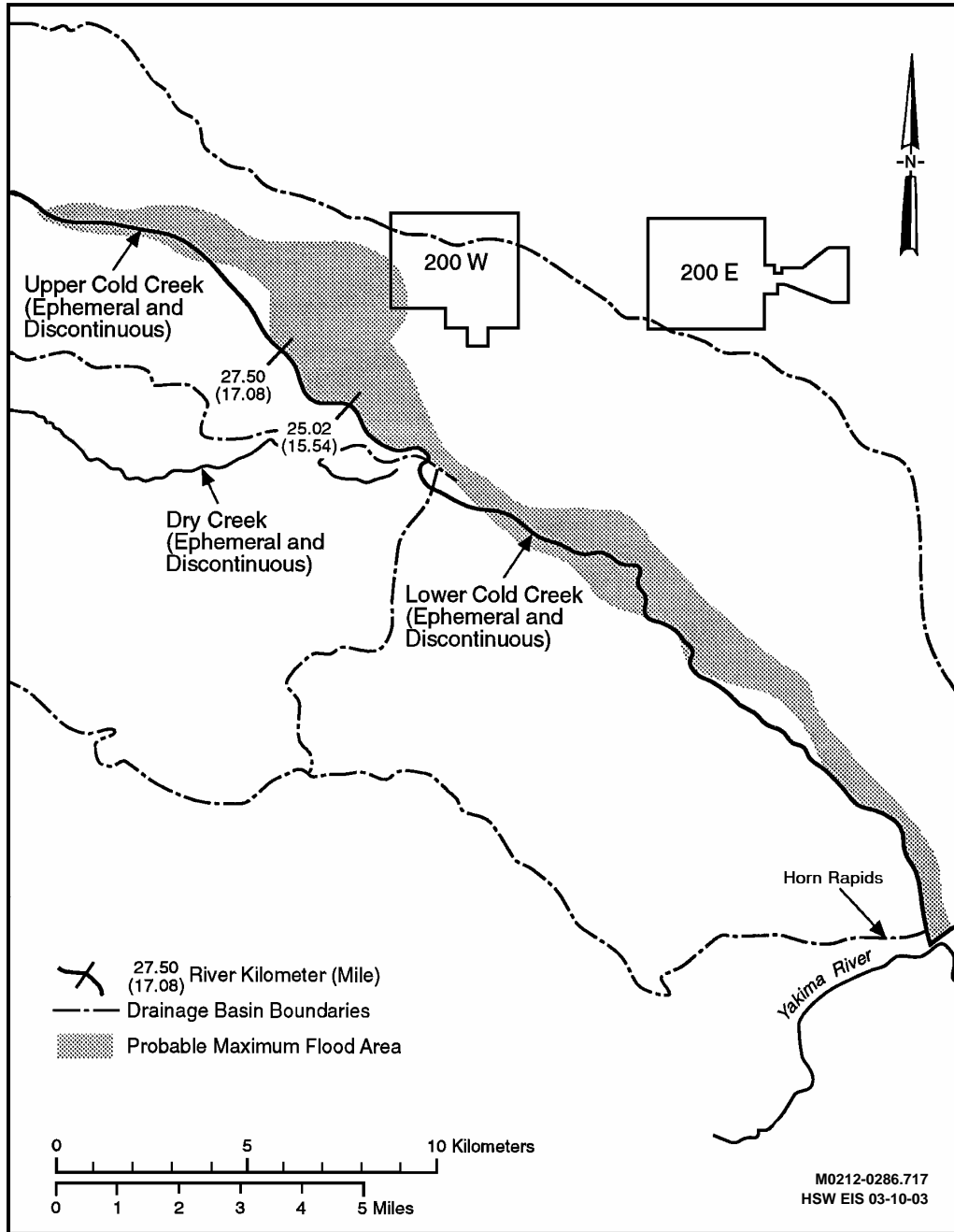
The vadose zone is that part of the subsurface found between the ground surface and the top of the saturated zone. At the Hanford Site, the thickness of the vadose zone ranges from 0 m (0 ft) near the Columbia River to greater than 100 m (328 ft) beneath parts of the central plateau (Hartman 2000). Unconsolidated glacio-fluvial sands and gravels of the Hanford formation make up most of the vadose zone. In some areas, however, such as west and south of 200 East Area and in some of the 100 Areas, the fluvial-lacustrine sediments of the Ringold Formation make up the lower part of the vadose zone.

Moisture movement through the vadose zone is important at the Hanford Site because it is the driving force for migration of most contaminants. Radioactive and hazardous wastes in the soil column from past intentional liquid-waste disposals, unplanned leaks, solid waste disposal, and underground tanks are potential sources of future vadose zone and groundwater contamination. Contaminants may continue to move slowly downward for long periods (tens to hundreds of years depending on recharge rates) after termination of liquid waste disposal.

Except for SALDS, the 200 Area TEDF ponds, and septic drain fields, artificial recharge (the process by which excess surface water is directed into the ground) to the vadose zone ended in the mid-1990s. Natural infiltration in the vadose zone causes older preexisting water to be displaced downward by newly infiltrated water. The amount of recharge at any particular site is highly dependent on the soil type and the presence of vegetation. Usually, vegetation reduces the amount of infiltration through the biological process of evapotranspiration.

Although most natural recharge is probably uniform flow (Jones et al. 1998), the vadose zone stratigraphy influences the movement of liquid through the soil column. Where conditions are favorable, lateral spreading of liquid effluent or local perched water zones may develop. Perched water zones form where downward moving moisture accumulates on top of low-permeability soil lenses or highly cemented horizons.

Preferential flow may also occur along discontinuities, such as clastic dikes and fractures. Clastic dikes are a common geologic feature in the suprabasalt sediments at the Hanford Site. Their most important feature is their potential to either enhance or inhibit vertical and lateral movement of contaminants in the subsurface, depending on textural relationships. Preferential flow may also take place via old, abandoned, or poorly sealed vadose zone and groundwater wells.



**Figure 4.16.** Extent of Probable Maximum Flood in Cold Creek Area (Skaggs and Walters 1981)

Subsurface source characterization, sediment sampling and characterization, and vadose zone monitoring are employed to describe the current and future configuration of contamination in the vadose zone.

#### 4.5.2.1 Vadose Zone Contamination

The Hanford Site has more than 800 former (referred to as past-practice) liquid disposal facilities. Radioactive liquid waste was discharged to the vadose zone through reverse (injection) wells, French drains, cribs, ponds, and ditches. Over the last 56 years, 1.5 to 1.7 billion m<sup>3</sup> (396 to 449 billion gal) of effluent were disposed of to the soils (Gephart 1999). Most effluent was released in the 200 Areas. The major groundwater contaminant plumes emanating from the 200 Areas are tritium and nitrate. The major source for both contaminants was liquid discharges resulting from chemical processing activities. These discharges also included technetium-99 and iodine-129 which, like tritium and nitrate, are mobile in groundwater. Carbon tetrachloride was also discharged to cribs near the Plutonium Finishing Plant in the 200 West Area. Vadose zone sources for these contaminants almost certainly remain beneath many past-practice disposal facilities.

Approximately 280 unplanned releases in the 200 Areas also contributed contaminants to the vadose zone (DOE-RL 1997). Many of these were releases from underground tanks and have contributed significant contamination to the vadose zone. In addition, approximately 50 active and inactive septic tanks and drain fields and numerous radioactive and non-radioactive landfills and dumps have impacted the vadose zone (DOE-RL 1997). The landfills are and were used to dispose of solid wastes, which, in most instances, are easier to locate, retrieve, and remediate than are liquid wastes.

A total of 149 single-shell tanks and 28 double-shell tanks have been used to store high-level radioactive and mixed wastes in the 200 Areas. The wastes resulted from uranium and plutonium recovery processes and, to a lesser extent, from strontium and cesium recovery processes. Of the single-shell tanks, 67 are assumed to have leaked an estimated total of 2839 to 3975 m<sup>3</sup> (750,000 to 1,050,000 gal) of contaminated liquid to the vadose zone (Hanlon 2001). The three largest tank leaks were 435,320 L (115,000 gal), 37,850 to 1,048,560 L (10,000 to 277,000 gal), and 265,980 L (70,365 gal). The average tank leak was between 41,640 and 60,565 L (11,000 and 16,000 gal) (Hanlon 2001).

The amount of contamination remaining in the vadose zone is uncertain. Several compilations of vadose zone contamination have been formulated through the past years. DOE-RL (1997) and Kincaid et al. (1998) contain the most recent inventories of contaminants disposed of to past-practice liquid disposal facilities in the 200 Areas. Dorian and Richards (1978) list contaminant inventories disposed of to most 100 Area past-practice facilities. Anderson (1990) lists inventories of effluents sent to single-shell tanks. A series of reports estimate the curies of gamma-emitting radionuclides and the volumes of contaminated soil associated with each single-shell tank farm. (See the series of online reports at the Hanford Tank Farm Vadose Zone Project (<http://www.gjo.doe.gov/programs/hanf/HTFVZ.html>). Their estimates for all locations for the three most widespread contaminants are 8901 Ci of cesium-137 in 395,550 m<sup>3</sup> of soil, 0.8611 Ci of europium-154 in 30,133 m<sup>3</sup> of soil, and 0.7424 Ci of cobalt-60 in 74,369 m<sup>3</sup> of soil.

#### 4.5.2.2 Vadose Zone Monitoring and Characterization Activities

Although disposal of untreated wastewater to the ground stopped in 1995 (Schmidt et al. 1996), contaminant movement still occurs in the soil column beneath past-practice sites. Vadose zone monitoring/characterization is one approach for evaluating the status of possible leaks or remobilization of contaminants caused by natural or artificial infiltration. The objectives of vadose-zone monitoring/characterization are to document the location of the contamination, determine the moisture and contaminant movement in the soil column, and assess the effectiveness of remedial actions.

DOE has been conducting an expedited response action to treat carbon tetrachloride contamination since 1992 at the 200-ZP-2 Operable Unit, located in the 200 West Area, with the concurrence of the EPA and the Washington State Department of Ecology (Ecology). Soil-vapor extraction is being used to remove carbon tetrachloride from the vadose zone as part of this expedited response action (Rohay 1999; Hartman et al. 2001). To track the effectiveness of the remediation effort, measurement of soil-vapor concentrations of chlorinated hydrocarbons are made at the inlet to the soil-vapor-extraction system and at individual off-line wells and probes through the soil-vapor extract sites. As of September 2002, 84,700 kg (187,000 lb) of carbon tetrachloride had been removed from the groundwater and vadose zone beneath the 200 West Area. The soil-vapor concentrations monitored deep within the vadose zone during the past few years suggest that soil vapor-extraction remediation has removed a substantial amount of the carbon tetrachloride from the vadose zone (Hartman et al. 2003).

Baseline vadose zone characterization has been conducted at the single-shell tank farms since 1995. Spectral gamma-ray logging detectors were used in approximately 800 boreholes at the 149 single-shell tanks to locate man-made gamma-emitting radionuclides in the soil. During the initial logging of the drywells, several areas were found with levels of contamination high enough to effectively saturate the gamma-ray detectors. Those areas were relogged in 2000 with more robust systems. The maximum radionuclide concentration (cesium-137) detected was about 100 million pCi/g. In addition, during 2000, 88 boreholes that were logged previously were relogged to determine whether contamination continues to move in the vadose zone. Data acquired in 22 of the 88 boreholes showed increases in concentration, suggesting possible continued contaminant movement through the vadose zone (Poston et al. 2001).

During 1999, boreholes around 25 inactive 200 East Area facilities, termed specific retention facilities, were monitored by spectral gamma-ray and neutron moisture methods. Specific retention facilities were designed to use the moisture-retention capability of the soil to retain contaminants. Ideally, liquids disposed of to specific retention facilities would be limited to less than about 10 percent of the soil volume between the facility and the groundwater, resulting in retention of the liquid in the soils (Waite 1991). Significant quantities of radionuclides and chemicals were discharged to specific retention trenches with some trenches receiving up to 1570 Ci of cesium-137, 475 Ci of strontium-90, and 89 Ci of technetium-99. The volume of liquid discharged to each trench is thought to be insufficient to drive contaminants through the vadose zone to groundwater. Therefore, the discharged contaminants remain in the soil column and these sites represent potential sources for future groundwater contamination at the Hanford Site. Of the 29 boreholes logged, 4 had previous spectral gamma logs for comparison. Logs from two of those boreholes showed that changes in subsurface distribution of man-made radionuclides

had occurred since 1992 (Horton and Randall 2000), indicating continued movement of contaminants in the vadose zone years after the facilities ceased operations.

### 4.5.3 Groundwater

Groundwater originates as surface water, either from natural recharge, such as rain, streams, and lakes, or from artificial recharge, such as reservoirs, excess irrigation, canal seepage, deliberate augmentation, industrial processing, and wastewater disposal.

#### 4.5.3.1 Hanford Site Aquifer System

Groundwater beneath the Hanford Site is found in an upper unconfined aquifer system and deeper basalt-confined aquifers. The unconfined aquifer system is also referred to as the suprabasalt aquifer system because it is within the sediments that overlie the basalt bedrock. Low-permeability layers of fine-grained sediment locally confine portions of the suprabasalt aquifer system. However, because the entire suprabasalt aquifer system is interconnected on a sitewide scale, it is referred to in this report as the Hanford unconfined aquifer system.

**Basalt-Confined Aquifer System.** Relatively permeable sedimentary interbeds and the more porous tops and bottoms of basalt flows form the confined aquifers within the Columbia River Basalts. The horizontal hydraulic conductivities of most of these aquifers fall in the range of  $10^{-10}$  to  $10^{-4}$  m/s ( $3 \times 10^{-10}$  to  $3 \times 10^{-4}$  ft/s). Saturated but relatively impermeable dense interior sections of the basalt flows have horizontal hydraulic conductivities ranging from  $10^{-15}$  to  $10^{-9}$  m/s ( $3 \times 10^{-15}$  to  $3 \times 10^{-9}$  ft/s), about five orders of magnitude lower than some of the confined aquifers that lie between these basalt flows (DOE 1988). Hydraulic-head information indicates that groundwater in the basalt-confined aquifers generally flows toward the Columbia River and, in some places, toward areas of enhanced vertical communication with the unconfined aquifer system (Hartman et al. 2001; DOE 1988; Spane 1987).

Recharge to the upper basalt-confined aquifer is believed to occur along the margins of the Pasco Basin as a result of precipitation infiltration and surface water where the basalt and interbeds are exposed at ground surface. Recharge may also occur through the Hanford/Ringold aquifer system, where a downward hydraulic gradient exists between the Ringold Formation and the confined and upper basalt-confined aquifers or from deeper basalt aquifers having an upward gradient.

South of the Umtanum Ridge/Gable Mountain area, groundwater in the upper basalt-confined aquifer system generally flows from west to east across the Hanford Site toward the Columbia River. The elevated regions to the west and southwest of the site are believed to be recharge areas for the system, and the Columbia River represents a discharge area.

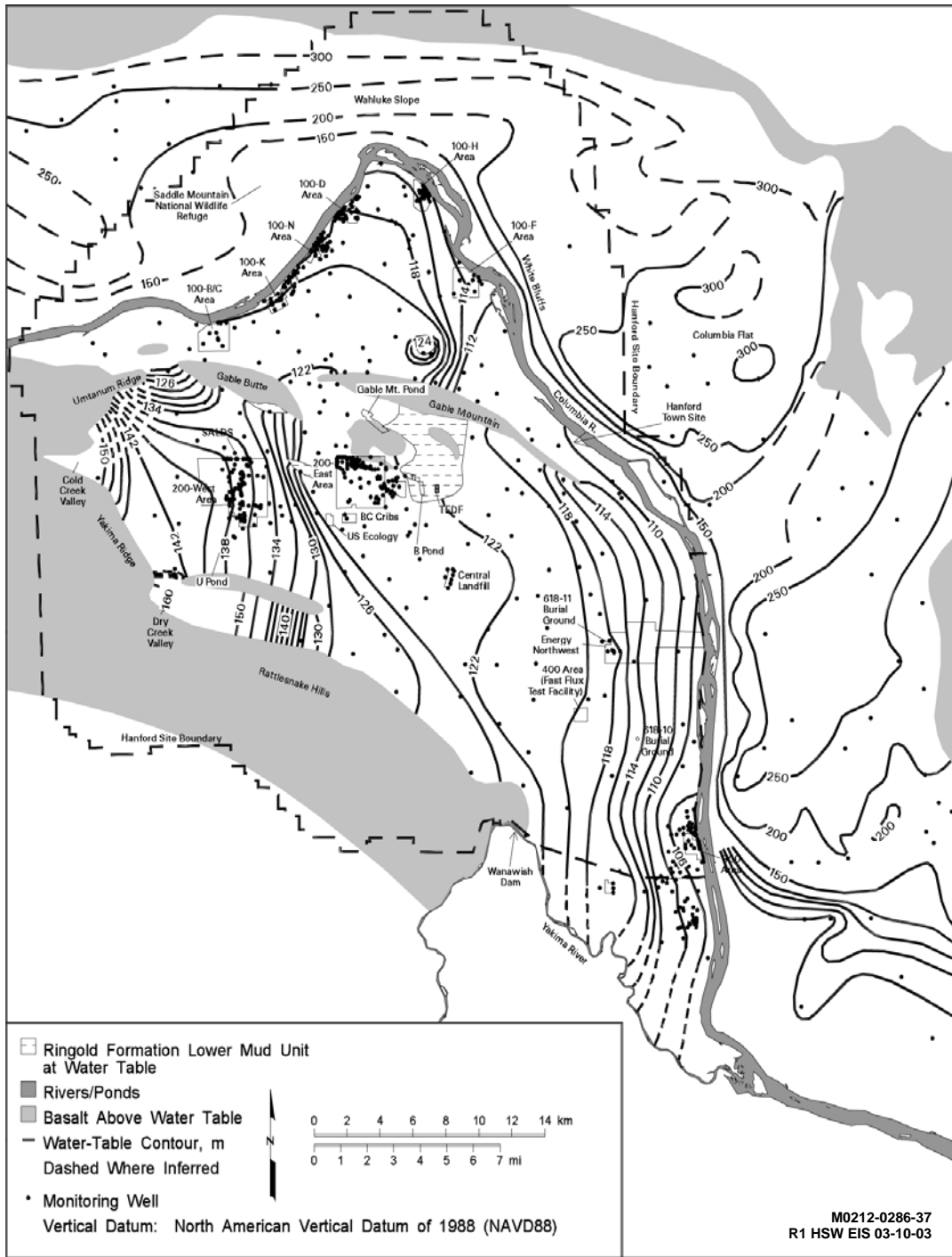
**Unconfined Aquifer System.** The unconfined aquifer is generally located in the unconsolidated to semi-consolidated Ringold and Hanford formation sediments that overlie the basalt bedrock. Where it is below the water table, the coarse-grained Hanford formation makes up the most permeable zones of the unconfined aquifer system.

The saturated thickness of the unconfined aquifer on the Hanford Site is greater than 61 m (200 ft) in some areas but pinches out along the flanks of the basalt ridges. Depth to the water table ranges from less than 0.3 m (1 ft) near the Columbia River to more than 106 m (348 ft) near the 200 Areas. Perched water-table conditions have been encountered in sediments above the unconfined aquifer in the 200 West Area (Airhart 1990; Last and Rohay 1993) and in irrigated offsite areas east of the Columbia River (Brown 1979). Because the Ringold sand and gravel sediments are more consolidated and are partially cemented, they are about 10 to 100 times less permeable than the sand and gravel sediments of the overlying Hanford formation. Horizontal hydraulic conductivities of sand and gravel facies within the Ringold Formation generally range from about 0.27 to 2.7 m/d (0.9 to 9 ft/d), compared to 305 to 3050 m/d (1000 to 10,000 ft/d) for the Hanford formation (DOE 1988). Mud-dominated units with the Ringold Formation are relatively impermeable.

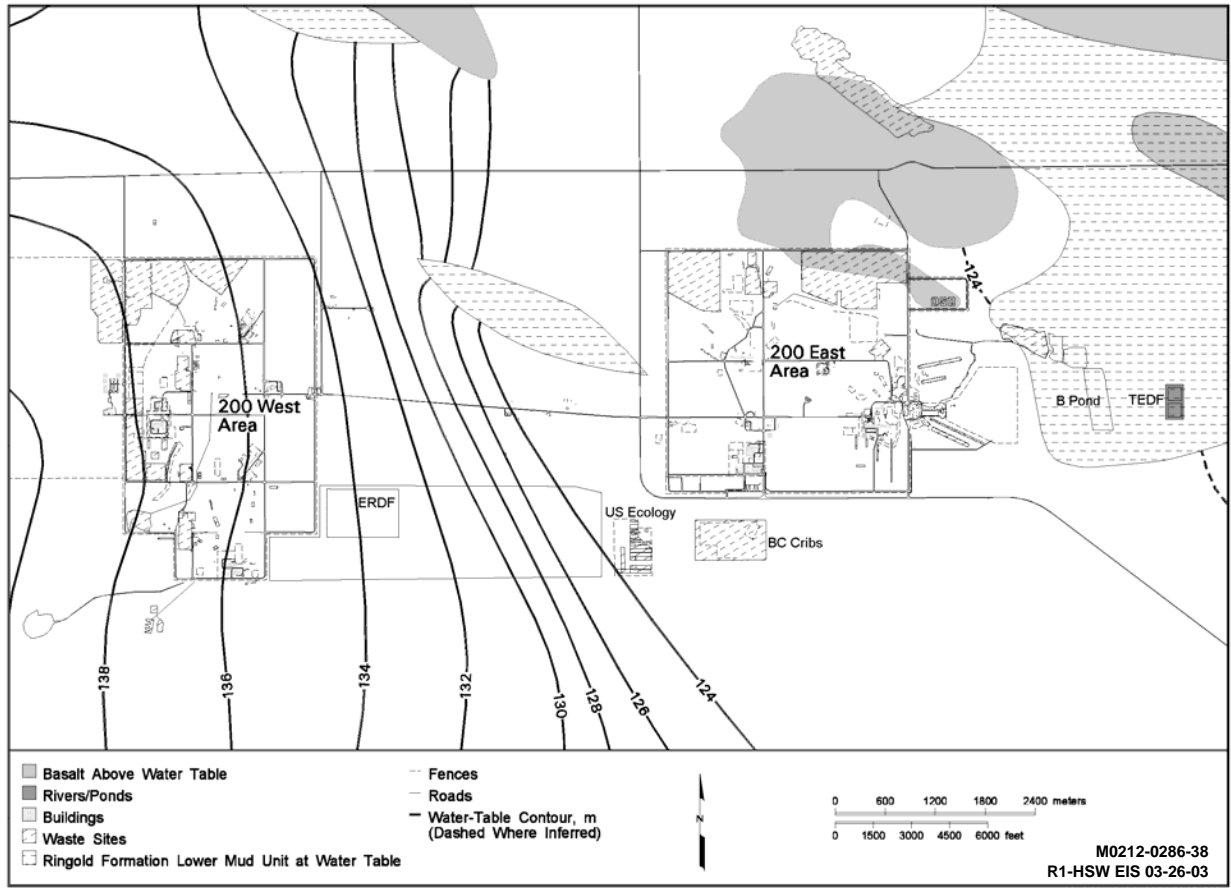
Groundwater in the unconfined aquifer at Hanford generally flows from recharge areas in the elevated region near the western boundary of the Hanford Site, and toward the Columbia River on the eastern and northern boundaries. The Columbia River is the primary discharge area for the unconfined aquifer. A map showing water table elevations for the Hanford Site and adjacent areas across the Columbia River is displayed in Figure 4.17. Figure 4.18 details the water table elevations for the 200 Areas. The Yakima River borders the Hanford Site on the southwest and is generally regarded as a source of recharge. Along the Columbia River shoreline, daily river level fluctuations may result in water table elevation changes of up to 3 m (10 ft). As the river stage rises, a pressure wave is transmitted inland through the groundwater.

Natural area recharge from precipitation across the entire Hanford Site ranges from about 0 to 10 cm/yr (0 to 4 in./yr), but is probably less than 2.5 cm/yr (1 in./yr) over most of the site (Gee and Heller 1985; Bauer and Vaccaro 1990; Fayer and Walters 1995). Between 1944 and the mid-1990s, the volume of artificial recharge from Hanford wastewater disposal was significantly greater than the natural recharge. An estimated  $1.7 \times 10^{12}$  L ( $4.44 \times 10^{11}$  gal) of liquid was discharged to disposal ponds and cribs during this period (Hartman et al. 2001). Because of the reduction in discharges, groundwater levels are falling, particularly around the operational areas (Hartman 2000).

After the beginning of Hanford operations, the water table rose about 27 m (89 ft) under the U Pond disposal area in the 200 West Area and about 9 m (30 ft) under disposal ponds near the 200 East Area. The volume of water that was discharged to the ground at the 200 West Area was actually less than that discharged at the 200 East Area. However, the lower conductivity of the aquifer near the 200 West Area inhibited groundwater movement in this area resulting in a higher groundwater mound. The presence of the groundwater mounds locally affected the direction of groundwater movement, causing radial flow from the discharge areas. Zimmerman et al. (1986) documented changes in water table elevations between 1950 and 1980. Until about 1980, the edge of the mounds migrated outward from the sources over time. Water levels have declined over most of the Hanford Site since 1984 because of decreased wastewater discharges (Hartman 2000). Although the reduction of wastewater discharges has caused water levels to drop significantly, a residual groundwater mound beneath the 200 West Area is still shown by the curved water table contours near this area (Figures 4.17 and 4.18).



**Figure 4.17.** Groundwater Elevations for the Unconfined Aquifer at Hanford, March 2001 (after Hartman et al. 2002b)



**Figure 4.18.** Groundwater Elevations for the Unconfined Aquifer at the 200 Areas (after Hartman et al. 2002b)

The saturated thickness and flow conditions in the unconfined aquifer are expected to return to pre-Hanford conditions with the decline and eventual cessation of artificial discharges at Hanford. Water levels have dropped in the vicinity of central areas in the site where the basalt crops out above the water table. Analyses by Cole et al. (1997) suggest the saturated thickness of the unconfined aquifer will decrease and areas of the aquifer may actually dry out. With this thinning and drying of the aquifer, which is predicted to occur in the area between Gable Butte and the outcrop south of Gable Mountain, the potential exists for the northern area of the unconfined aquifer to become hydrologically separated from the area south of Gable Mountain and Gable Butte. Therefore, flow from the 200 West Area and the northern half of the 200 East Area, that currently migrates through the gap between Gable Butte and Gable Mountain, will be effectively cut off in the next 200 to 300 years. In time, the overall water table (including groundwater mounds near the 200 East and West Areas) will decline, and groundwater movement from the 200 Area Plateau will shift to a dominantly west-to-easterly pattern of flow toward points of discharge along the Columbia River between the Old Hanford townsite and the Energy Northwest facility.



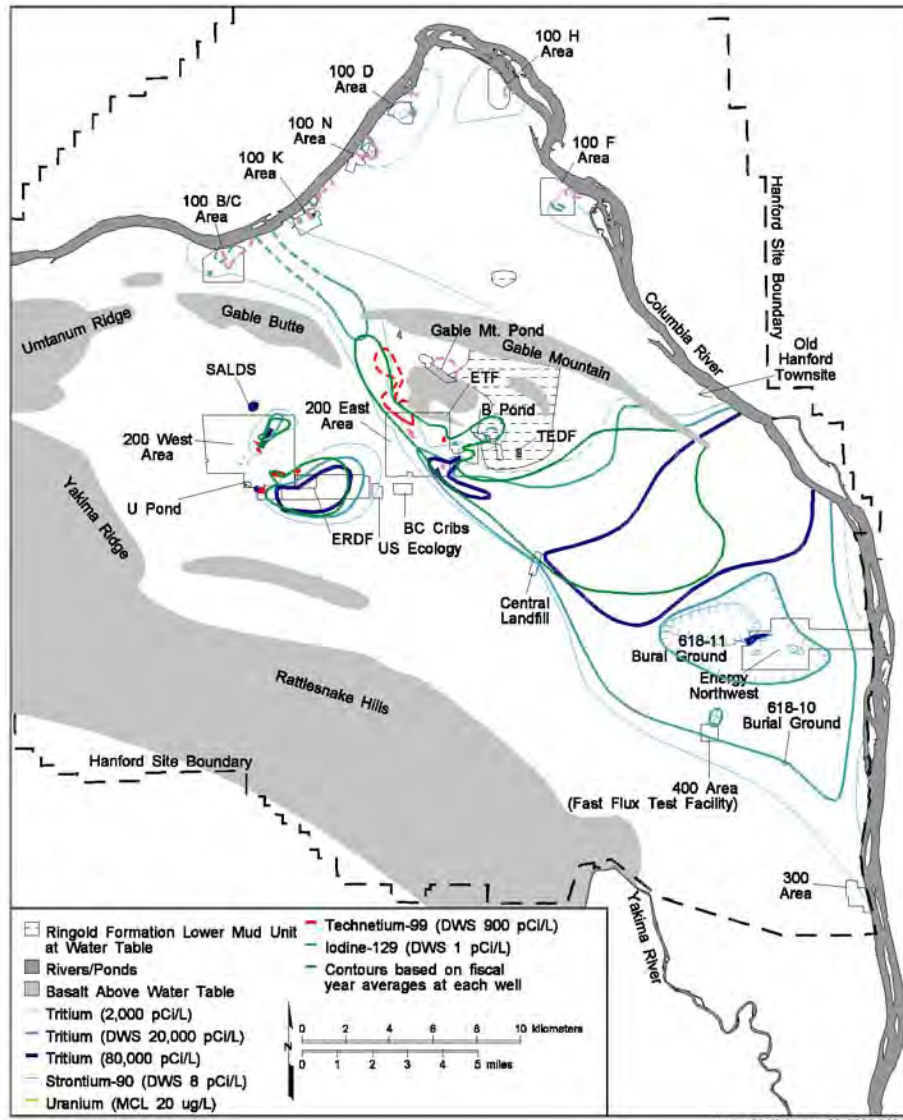
During 2000, the groundwater mounds have become less prominent. Water levels east of the 200 East Area have dropped below the top of a fine-grained confining unit, creating a barrier to movement in the surrounding unconfined aquifer (Hartman et al. 2001). Beneath this confining unit, the uppermost aquifer is a transmissive unit in the Ringold Formation. Groundwater flow in the confined aquifer is still influenced by the recharge mound.

#### **4.5.3.2 Groundwater Quality**

Groundwater beneath large areas of the Hanford Site has been impacted by radiological and chemical contaminants resulting from past Hanford Site operations. These contaminants were primarily introduced through wastewater discharged to cribs, ditches, injection wells, and ponds (Kincaid et al. 1998). Additional contaminants from spills, leaking waste tanks, and 618-10 and 618-11 Burial Grounds have also impacted groundwater in some areas. Contaminant concentrations in the existing groundwater plumes are expected to decline through radioactive decay, chemical degradation, and dispersion. However, contaminants also exist within the vadose zone beneath waste sites (see Section 4.5.2), as well as in waste storage and disposal facilities. These contaminants have a potential to continue to move downward into the aquifer. Some contaminants, such as tritium, move with the groundwater while the movement of other contaminants is slower because they react with or are sorbed on the surface of minerals within the aquifer or the vadose zone. Groundwater contamination is monitored and is being actively remediated in several areas through pump-and-treat operations.

Contaminant concentrations in groundwater were compared with established drinking water standards as a benchmark for quality of the groundwater resource. These benchmark standards include the maximum contaminant level (MCL) and drinking water standard (DWS) for specific chemicals and radionuclides, which are legally enforceable limits for public drinking water supplies set by EPA or the Washington State Department of Health (WDOH). DOE Order 5400.5 establishes a limit for dose from radionuclides in public drinking water supplies operated by DOE or its contractors (DOE 1993). The dose limit is 4 mrem/yr (as total effective dose equivalent) from consumption of water at 2 L/day, which is intended to provide protection equivalent to that of the EPA and state standards. The published DOE derived concentration guide (DCG) for a specific radionuclide in drinking water may also be used as a benchmark for groundwater quality in the same manner as the EPA and state standards. The DCG represents the concentration of each radionuclide in drinking water that would result in a dose of 100 mrem/yr at a consumption rate of 2 L/day. Therefore, the DOE standard for a given radionuclide in drinking water corresponds to 4 percent of the DCG for that radionuclide.

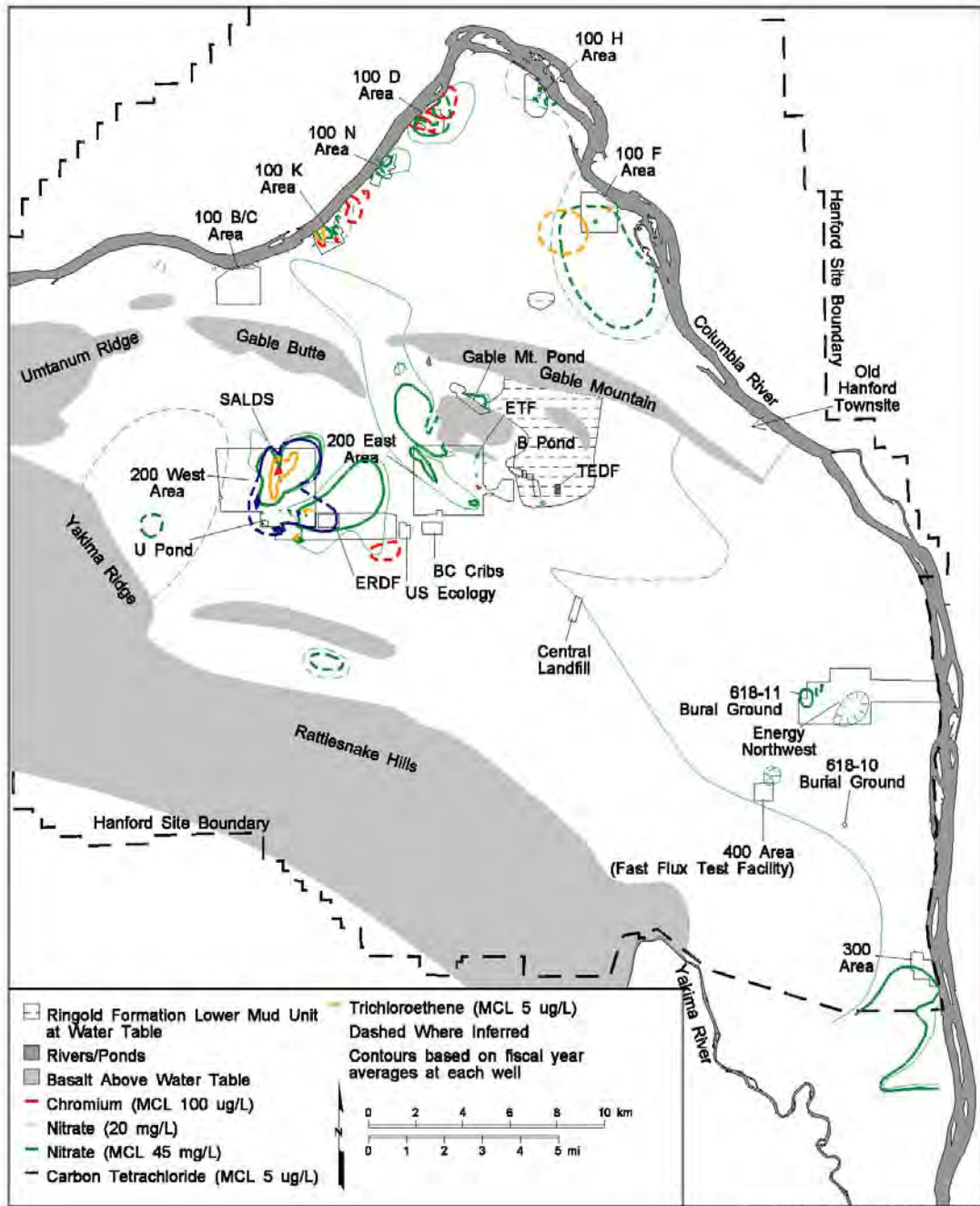
Radiological constituents, including carbon-14, cesium-137, iodine-129, strontium-90, technetium-99, total alpha, total beta, tritium, uranium, and plutonium-239/240, were detected at concentrations greater than the MCL in one or more onsite wells within the unconfined aquifer. Concentrations of strontium-90, tritium, uranium, and plutonium were detected at levels greater than their respective DOE DCGs. Certain non-radioactive chemicals regulated by the EPA or the State of Washington (carbon tetrachloride, chloroform, chromium, cyanide, cis-1, 2 dichloroethene, fluoride, nitrate, sulfate, and trichloroethene) were also present in Hanford Site groundwater. Figure 4.19 shows the distribution of some radiological contamination in Hanford Site groundwater and Figure 4.20 shows the distribution of some hazardous chemical



ERDF – Environmental Restoration Disposal Facility  
 ETF – Effluent Treatment Facility  
 SALDS – State-Approved Land Disposal Structure  
 TEDF – Treated Effluent Disposal Facility

M0212-0286-39  
 R1 HSW EIS 03-10-03

**Figure 4.19.** Distribution of Major Radionuclides in Groundwater at Concentrations Above the Drinking Water Standards During FY 2001 (after Hartman et al. 2002b). Maximum concentrations are listed in Table 4.10.



can\_gw01\_12 December 21, 2001 9:48 AM  
M0212-0286-40  
R1 HSW EIS 03-10-03

ERDF – Environmental Restoration Disposal Facility  
ETF – Effluent Treatment Facility  
SALDS – State-Approved Land Disposal Structure  
TEDF – Treated Effluent Disposal Facility

**Figure 4.20.** Distribution of Major Hazardous Chemicals in Groundwater at Concentrations Above the Drinking Water Standards During FY 2001 (after Hartman et al. 2002b). Maximum concentrations are listed in Table 4.10.

**Table 4.10.** Maximum Concentrations of Groundwater Contaminants at Hanford in FY 2001 (Hartman et al. 2002b)

Contaminant (alphabetical order)	DWS or MCL [DCG] <sup>(a)</sup>	Units	100-B/C		100-K		100-N		100-D		100-H		100-F		200 West
			Wells	Shore <sup>(b)</sup>	Wells	Shore <sup>(b)</sup>	Wells	Shore <sup>(b)</sup>	Wells	Shore <sup>(b)</sup>	Wells	Shore <sup>(b)</sup>	Wells	Shore	Wells
Carbon tetrachloride	5	µg/L													<b>7400</b>
Carbon-14	2000 [70,000]	pCi/L			<b>16,300</b>	ND									
Cesium-137	200 [3000]	pCi/L													
Chloroform	100	µg/L													160
Chromium (dissolved)	100	µg/L	86	48	<b>1332</b>	<b>110</b>	<b>173</b>	12	<b>4750</b>	<b>521</b>	<b>160</b>	88	79	19	<b>248</b>
Cobalt-60	100 [5000]	pCi/L													
Cyanide	200	µg/L													
cis-1,2 Dichloroethene	70	µg/L													
Fluoride	4	mg/L									0.32				<b>4.9</b>
Gross alpha	15	pCi/L									<b>33</b>				<b>18</b>
Gross beta	50	pCi/L	<b>270</b>	50	<b>8670</b>	<b>82</b>	<b>3440</b>	5.9	<b>75</b>	14	<b>278</b>	27	<b>80</b>	10	<b>28,700</b>
Iodine-129	1 [500]	pCi/L													<b>64</b>
Nitrate (as NO <sub>3</sub> <sup>-</sup> )	45	mg/L	34	<b>67</b>	<b>160</b>	<b>74</b>	<b>125</b>	22	<b>86</b>	<b>88</b>	<b>150</b>	17	<b>158</b>	(c)	<b>1300</b>
Nitrite (as NO <sub>2</sub> )	3.3	mg/L							<b>8.3</b>						<b>27</b>
Plutonium 239/240	NA [30]	pCi/L													undetected
Strontium-90	8 [1000]	pCi/L	<b>135</b>	<b>15.8</b>	<b>5210</b>	ND	<b>9690</b>	<b>9690</b>	<b>12</b>	1.4	<b>38</b>	<b>14</b>	<b>38</b>	1.7	<b>69</b>
Technetium-99	900 [100,000]	pCi/L									471				<b>81,500</b>
Trichloroethene	5	µg/L			<b>19</b>								<b>16</b>		<b>21</b>
Tritium	20,000 [2,000,000]	pCi/L	<b>40,700</b>	<b>31,300</b>	<b>1,750,000</b>	6140	<b>36,900</b>	<b>29,700</b>	18,600	<b>22,100</b>	7740	5460	<b>38,600</b>	1380	<b>1,540,000</b>
Uranium	30 [790]	µg/L									<b>49</b>		23		<b>2140</b>

Note: Table lists highest concentration for fiscal year 2001 in each geographic region. Concentrations in **bold** exceed drinking water standards. Concentrations in **bold italic** exceed DOE derived concentration guides. Blank spaces indicate the constituent is not of concern in the given area. ND = not detected.

(a) DWS = drinking water standard; MCL = maximum contaminant level; DCG = derived concentration guide (based on 100 mrem/yr). See PNNL-13080 (Hartman 2000) for more information on these standards.

(b) Shoreline sampling includes aquifer sampling tubes, seeps, and shoreline wells from fall 2000. 200 East Area plumes monitored at Old Hanford Townsite.

(c) Fiscal year 2001 results appear erroneous. Past year's results up to 55 mg/L.

Table 4.10. (contd)

Contaminant (alphabetical order)	DWS or MCL [DCG] <sup>(a)</sup>	Units	200 East		400	600	300		618-11	Richland North	Basalt-Confined
			Wells	Shore <sup>(b)</sup>	Wells	Wells	Wells	Shore <sup>(b)</sup>	Wells	Wells	Wells
Carbon tetrachloride	5	µg/L				ND					
Carbon-14	2000 [70,000]	pCi/L									
Cesium-137	200 [3000]	pCi/L	<b>1910</b>								
Chloroform	100	µg/L				0.43					
Chromium (filtered)	100	µg/L	<b>1640</b>			17					
Cobalt-60	100 [5000]	pCi/L78	78								ND
Cyanide	200	µg/L	<b>423</b>								29
cis-1,2 Dichloroethene	70	µg/L					<b>190</b>				
Fluoride	4	mg/L								<b>15</b>	<b>8.5</b>
Gross alpha	15	pCi/L	<b>357</b>				<b>43</b>	<b>88</b>	8.0	10	3.5
Gross beta	50	pCi/L	<b>25,700</b>	36			<b>282</b>	33	<b>84</b>	24	<b>330</b>
Iodine-129	1 [500]	pCi/L	<b>10</b>	0.27							ND
Nitrate (as NO <sub>3</sub> <sup>-</sup> )	45	mg/L	<b>748</b>	<b>100</b>	<b>87</b>	22	<b>89</b>	<b>104</b>	<b>93</b>	<b>162</b>	38
Nitrite (as NO <sub>2</sub> )	3.3	mg/L			0.36						
Plutonium 239/240	NA [30]	pCi/L	<b>63</b>								
Strontium-90	8 [1000]	pCi/L	<b>12,000</b>								ND
Technetium-99	900 [100,000]	pCi/L	<b>13,000</b>	112							<b>1120</b>
Trichloroethene	5	µg/L					<b>5.3</b>			<b>5.1</b>	
Tritium	20,000 [2,000,000]	pCi/L	<b>4,300,000</b>	<b>107,000</b>	<b>57,600</b>	<b>49,800</b>	<b>57,700</b>	11,700	<b>8,370,000</b>	551	5770
Uranium	30 [790]	µg/L	<b>678</b>				<b>205</b>	<b>210</b>	11	23	

Note: Table lists highest concentration for fiscal year 2001 in each geographic region. Concentrations in **bold** exceed drinking water standards. Concentrations in **bold italic** exceed DOE derived concentration guides. Blank spaces indicate the constituent is not of concern in the given area. ND = not detected.

(a) DWS = drinking water standard; MCL = maximum contaminant level; DCG = derived concentration guide (based on 100 mrem/yr). See PNNL-13080 (Hartman 2000) for more information on these standards.

(b) Shoreline sampling includes aquifer sampling tubes, seeps, and shoreline wells from fall 2000. 200 East Area plumes monitored at Old Hanford Townsite.

(c) Fiscal year 2001 results appear erroneous. Past year's results up to 55 mg/L.

constituents above the applicable DWSs. The area of contaminant plumes on the Hanford Site with concentrations exceeding drinking water standards was estimated to be 208 km<sup>2</sup> (80.3 mi<sup>2</sup>) in fiscal year (FY) 2001. This estimate is 1 percent smaller than that for FY 2000. The decrease is primarily due to shrinkage of the tritium plume from 200 East Area, which was caused primarily by radioactive decay. Table 4.10 shows the maximum concentrations of groundwater contaminants observed on the Hanford Site during FY 2001, along with DWS and DCG values (Hartman et al. 2002b).

The upper basalt-confined aquifer is monitored by about 40 wells that are sampled annually to triennially. Most of these wells are located near the 200 Areas. During the year 2001, seventeen upper basalt-confined aquifer wells were sampled. Tritium, iodine-129, and nitrate were sampled in most of the wells, as they are most mobile in groundwater, the most widespread in the overlying unconfined aquifer, and provide an early warning of potential contamination in the upper basalt-confined aquifer. Results for each of these constituents were less than their respective drinking water standards for 2001. Monitoring results for the groundwater in the upper basalt-confined aquifer in 2000 indicate a tritium concentration of 5770 pCi/L beneath B Pond. Levels of tritium in this location are believed to be a result of downward migration from the overlying unconfined aquifer and have declined since 1996. The highest nitrate concentration, 38 mg/L, was found in the northern section of the 200 East Area in well 299-E33-12. Iodine-129 was not detected in 2001 (Hartman et al. 2002b).

#### **4.5.3.3 200 Areas Hydrology**

In the 200 West Area, the water table occurs almost entirely in the Ringold Unit E gravels, while in the 200 East Area, it occurs primarily in the Hanford formation and in the Ringold Unit A gravels. Along the southern edge of the 200 East Area, the water table is in the Ringold Unit E gravels. The upper Ringold facies were eroded in most of the 200 East Area by the Missoula floods that subsequently deposited Hanford gravels and sands on the remains of the Ringold Formation. Because the Hanford formation sand and gravel deposits are much more permeable than the Ringold gravels, the water table is relatively flat in the 200 East Area, but groundwater flow velocities are higher. On the north side of the 200 East Area, evidence appears of erosional channels that may allow communication between the unconfined and uppermost basalt-confined aquifer (Graham et al. 1984; Jensen 1987).

Groundwater occurs in the 200 West Area within the Ringold Formation primarily under unconfined conditions, approximately 61 to 87 m (200 to 285 ft) beneath the surface. The saturated section is 110 m (360 ft) thick. Hydraulic conductivities measured in the 200 West Area in the Ringold Unit E aquifer range from approximately 0.02 to 60 m/day (0.06 to 200 ft/day). Hydraulic conductivities range from 0.5 to 1.2 m/day (1.6 to 4 ft/day) in the semi-confined to confined Ringold Unit A gravels. Groundwater in the 200 West Area generally flows east toward the 200 East Area. In the northwest corner of the 200 East Area, groundwater has flowed northward through the gap between Gable Butte and Gable Mountain. This northward flow appears to be diminishing (Hartman et al. 2002b).

Natural recharge from precipitation falling on the Hanford Site is highly variable spatially and temporally, ranging from near zero to more than 100 mm/yr, depending on climate, vegetation, and soil texture (Gee et al. 1992; Fayer and Walters 1995). Areas with shrubs and fine-textured soils like silt loams tend to have low recharge rates, while areas with little vegetation and coarse-textured soils, such as

dune sands, tend to have high recharge rates. Recharge is also generally higher near the basalt ridges because of greater precipitation and runoff. Past estimates of recharge have been summarized in earlier status reports (Thorne and Chamness 1992; Thorne et al. 1993). Fayer and Walters (1995) developed a natural recharge map for 1979 conditions to support the Hanford Site three-dimensional groundwater and transport model. The distributions of soil and vegetation types were mapped first. A recharge rate was then assigned to each combination on the basis of data from lysimeters, tracer studies, neutron probe measurements, and computer modeling. Estimated recharge rates for 1992 were found to range from 2.6 to 127 mm/yr, and the total volume of natural recharge from precipitation over the Hanford Site was estimated at  $8.47 \times 10^6$  m<sup>3</sup>/yr. This value is of the same order of magnitude as the artificial recharge to the 200 Area waste disposal facilities during 1992 and is about half the volume of discharge to these facilities during 1979 (Fayer and Walters 1995).

The other source of recharge to the unconfined aquifer is artificial recharge from wastewater disposal. Over the past 50 years, the large volume of wastewater discharged to disposal facilities at the Hanford Site has significantly affected groundwater flow and contaminant transport in the unconfined aquifer. The volume of artificial recharge has decreased significantly during the past 10 years and continues to decrease. Wurstner et al. (1995) summarized the major discharge facilities incorporated in the three-dimensional model. Cole et al. (1997) summarized the major wastewater discharges from past and future sources.

Depth to groundwater in the 200 East Area ranges from 97 m (320 ft) in the southeast to 37 m (120 ft) in the vicinity of the 216-B-3C pond (B Pond mound). A downward gradient has formed in the B Pond vicinity due to groundwater mounding from discharges. Based on data collected in March 2002 for well pair 699-43-42J (water table) and 699-42-42B (7.37 m deeper), the downward gradient was 0.038. This is greater than the horizontal gradient, 0.002. Groundwater flow in the 200 East Area is to the southeast. Interconnection between the unconfined and lower confined aquifer is possible across the Central Plateau. However, except for the area near the erosional windows that occur in the basalt several kilometers north of the 200 East Area and B Pond vicinity in the 200 East Area, no indication is shown of aquifer interconnection. Several kilometers north of the 200 East Area, an absence of confining layer(s) is associated with an erosional window that has resulted in enhanced interconnection of the aquifers in this area. Hydraulic conductivities of the unconfined aquifer in the 200 East Area range from 150 to 300 m/day (500 to 1000 ft/day). Flow may split east of Gable Butte, one path heading north toward the gap between Gable Butte and Gable Mountain, and the other path east to the Columbia River.

Groundwater is monitored in the vicinity of the LLBGs as a result of interim status requirements of WAC 173-303. The LLBGs are divided into five low-level waste management areas (LLWMAs). Since 1996, groundwater has not been monitored within LLWMA-5, the location of the 218-W-6 Burial Ground, as the site has never received waste.

LLWMA-1 consists of the 218-E-10 Burial Ground. Well 299-E33-34, a downgradient monitoring well, exceeded the critical mean for specific conductance in 2000, but this was related to the nitrate plume with an upgradient source in the northern portion of this LLWMA (Poston et al. 2001).

LLWMA-2 is located in the 200 East Area and includes all of the 218-E-12B Burial Ground. Upgradient well 299-E34-7 exceeded the critical mean value for specific conductance in 2000. Sulfate and calcium are the major contributors to the increase and their source is not known. However, only 0.6 m (2 ft) of water remains in this well, which is at the top of the basalt, and the increases may be due to basalt chemistry. Well 299-E34-7 also exceeded the comparison value for total organic carbon in 2000. Results for volatile and semi-volatile organics were less than detection limits, with the exception of bis (2-ethylhexyl) phthalate at 1.7 µg/L.

LLWMA-3 includes the 218-W-3A, 218-W-3AE, and 218-W-5 Burial Grounds in the 200 West Area. Indicator parameter data from upgradient wells were statistically evaluated and values from downgradient wells were compared with established values from upgradient wells in 2000. The critical mean value for specific conductance was exceeded in an upgradient well, but is due to increases in sulfate and nitrate from upgradient sources. None of the other wells in LLWMA-3 exceeded contamination parameters during 2000. Several of the wells in LLWMA-3 have gone dry, as the water table continues to decline.

LLWMA-4 is located in the 200 West Area and includes 218-W-4B and 218-W 4C Burial Grounds. Indicator parameter data from upgradient wells were statistically evaluated and values from downgradient wells were compared with established values from upgradient wells in 2000. The critical mean value for total organic halides was exceeded in one downgradient well in 2000, caused by carbon tetrachloride from an upgradient source. Groundwater in LLWMA-4 is being actively remediated using pump-and-treat methods.

DOE has an Integrated Monitoring Plan for the Hanford Groundwater Monitoring Project (Hartman et al. 2002a) that integrates all of the separate monitoring plans that are prepared for RCRA, CERCLA, and DOE Orders. Groundwater is a dynamic system, and the monitoring network is annually reviewed and modified to accommodate changes. Any additional wells for the LLBGs will be defined through the RCRA permit process and will be drilled under the TPA M-24 Milestone. DOE-RL has worked with EPA and Ecology to revise the M-24 Milestone as needed, and tentative agreement has been reached on a four-year schedule for drilling additional wells, including 17 proposed new wells for the LLBG waste management areas. The M-24 TPA Change Package for the new wells was issued for public comment in September 2003. A total of 1,278 wells are scheduled to be sampled in fiscal years 2003, 2004, or 2005 for all programs combined.

## 4.6 Biological and Ecological Resources

The Hanford Site is characterized as a shrub-steppe ecosystem (Daubenmire 1970). Such ecosystems are typically dominated by a shrub overstory with a grass understory. In the early 1800s, the dominant plant in the area was big sagebrush underlain by perennial Sandberg's bluegrass and bluebunch wheatgrass. With the advent of settlement, livestock grazing and agricultural production contributed to colonization by nonnative vegetation species that currently dominate the landscape. Although agriculture and production of livestock were the primary activities at the beginning of the twentieth century, these activities ceased when the site was established in 1943. Remnants of past agricultural practices are still evident.



LLWMA-2 is located in the 200 East Area and includes all of the 218-E-12B Burial Ground. Upgradient well 299-E34-7 exceeded the critical mean value for specific conductance in 2000. Sulfate and calcium are the major contributors to the increase and their source is not known. However, only 0.6 m (2 ft) of water remains in this well, which is at the top of the basalt, and the increases may be due to basalt chemistry. Well 299-E34-7 also exceeded the comparison value for total organic carbon in 2000. Results for volatile and semi-volatile organics were less than detection limits, with the exception of bis (2-ethylhexyl) phthalate at 1.7 µg/L.

LLWMA-3 includes the 218-W-3A, 218-W-3AE, and 218-W-5 Burial Grounds in the 200 West Area. Indicator parameter data from upgradient wells were statistically evaluated and values from downgradient wells were compared with established values from upgradient wells in 2000. The critical mean value for specific conductance was exceeded in an upgradient well, but is due to increases in sulfate and nitrate from upgradient sources. None of the other wells in LLWMA-3 exceeded contamination parameters during 2000. Several of the wells in LLWMA-3 have gone dry, as the water table continues to decline.

LLWMA-4 is located in the 200 West Area and includes 218-W-4B and 218-W 4C Burial Grounds. Indicator parameter data from upgradient wells were statistically evaluated and values from downgradient wells were compared with established values from upgradient wells in 2000. The critical mean value for total organic halides was exceeded in one downgradient well in 2000, caused by carbon tetrachloride from an upgradient source. Groundwater in LLWMA-4 is being actively remediated using pump-and-treat methods.

DOE has an Integrated Monitoring Plan for the Hanford Groundwater Monitoring Project (Hartman et al. 2002a) that integrates all of the separate monitoring plans that are prepared for RCRA, CERCLA, and DOE Orders. Groundwater is a dynamic system, and the monitoring network is annually reviewed and modified to accommodate changes. Any additional wells for the LLBGs will be defined through the RCRA permit process and will be drilled under the TPA M-24 Milestone. DOE-RL has worked with EPA and Ecology to revise the M-24 Milestone as needed, and tentative agreement has been reached on a four-year schedule for drilling additional wells, including 17 proposed new wells for the LLBG waste management areas. The M-24 TPA Change Package for the new wells was issued for public comment in September 2003. A total of 1,278 wells are scheduled to be sampled in fiscal years 2003, 2004, or 2005 for all programs combined.

## 4.6 Biological and Ecological Resources

The Hanford Site is characterized as a shrub-steppe ecosystem (Daubenmire 1970). Such ecosystems are typically dominated by a shrub overstory with a grass understory. In the early 1800s, the dominant plant in the area was big sagebrush underlain by perennial Sandberg's bluegrass and bluebunch wheatgrass. With the advent of settlement, livestock grazing and agricultural production contributed to colonization by nonnative vegetation species that currently dominate the landscape. Although agriculture and production of livestock were the primary activities at the beginning of the twentieth century, these activities ceased when the site was established in 1943. Remnants of past agricultural practices are still evident.

The Columbia River borders the DOE-managed portion of the Hanford Site to the east. Operation of Priest Rapids Dam upstream of the site accommodates maintenance of intakes at the Hanford Site and helps to manage anadromous fish populations. The Columbia River and associated riparian zones provide habitat for numerous wildlife and vegetation species.

Large areas of the Hanford Site have experienced range fires that have greatly influenced the vegetation canopy and distribution of wildlife. In 1984, a major fire burned across 800 km<sup>2</sup> (310 mi<sup>2</sup>) of the Hanford Site (Price et al. 1986). From June 27 through July 2, 2000, the *24 Command Fire* burned across the Hanford Site consuming most of the shrub-steppe habitat on the ALE Unit, a small section of the McGee-Riverlands Unit, and other southwestern portions of the site. The fire consumed a total of 655 km<sup>2</sup> (250 mi<sup>2</sup>) of federal, state, and private lands before it was controlled (BAER 2000). Range fires are a component of natural plant succession.

The Hanford Site Fire Department provides the planning to guide the management of wildland and prescribed fires on the site. This planning is designed to ensure safety, protect facilities and resources, and restore and perpetuate natural processes.

DOE manages the Hanford Site through the Hanford Site Biological Resources Management Plan (BRMaP; DOE-RL 2001) and the Hanford Site Biological Resources Mitigation Strategy (BRMiS; DOE-RL 2003b) that were adopted after preparation of the HCP EIS (DOE 1999), which included an ecosystem analysis.

#### **4.6.1 Vegetation**

Plants at the Hanford Site are adapted to low annual precipitation, low water-holding capacity of the rooting substrate (sand), dry summers, and cold winters. Range fires that burn through the area during dry summers have reduced species that are less resistant to fire (for example, big sagebrush) and have allowed more opportunistic and fire-resistant species a chance to become established. Perennial shrubs and bunchgrasses generally dominate native plant communities on the site. However, Euro-American settlement and development have resulted in the proliferation of non-native species. Of the 590 species of vascular plants recorded on the Hanford Site, approximately 20 percent of the species are considered nonnative (Sackschewsky et al. 1992). Cheatgrass is the dominant non-native species. It is an aggressive colonizer and has become well established across the site (Rickard and Rogers 1983). The biodiversity inventories conducted by The Nature Conservancy of Washington (TNC 1999) have identified 85 additional taxa, establishing the actual number of plant taxa on the Hanford Site at 675.

The Nature Conservancy of Washington also conducted rare plant surveys. The Conservancy found 112 populations/occurrences of 28 rare plant taxa on the Hanford Site. When combined with observations preceding the 1994-1999 inventories, a total of 127 populations of 30 rare plant taxa have been documented on the Hanford Site (TNC 1999).

Figure 4.21 shows existing vegetation and land use areas on the Hanford Site, prior to the *24 Command Fire* that occurred in late June 2000. Table 4.11 presents a list of common plant species in shrub-steppe and riparian areas.

**Table 4.11.** Common Vascular Plants on the Hanford Site  
(Taxonomy follows Hitchcock and Cronquist 1973)

<b>A. Shrub-Steppe Species</b>	<b>Scientific Name</b>
<b>Shrub</b>	
big sagebrush	<i>Artemisia tridentata</i>
bitterbrush	<i>Purshia tridentata</i>
gray rabbitbrush	<i>Chrysothamnus nauseosus</i>
green rabbitbrush	<i>Chrysothamnus viscidiflorus</i>
snow buckwheat	<i>Eriogonum niveum</i>
spiny hopsage	<i>Grayia (Atriplex) spinosa</i>
threetip sagebrush	<i>Artemisia tripartita</i>
<b>Perennial Grasses</b>	
bluebunch wheatgrass	<i>Agropyron spicatum</i>
bottlebrush squirreltail	<i>Sitanion hystrix</i>
crested wheatgrass	<i>Agropyron desertorum (cristatum)<sup>(a)</sup></i>
indian ricegrass	<i>Oryzopsis hymenoides</i>
needle-and-thread grass	<i>Stipa comata</i>
prairie junegrass	<i>Koeleria cristata</i>
sand dropseed	<i>Sporobolus cryptandrus</i>
Sandberg's bluegrass	<i>Poa sandbergii (secunda)</i>
thickspike wheatgrass	<i>Agropyron dasytachyum</i>
<b>Perennial Forbs</b>	
bastard toad flax	<i>Comandra umbellata</i>
buckwheat milkvetch	<i>Astragalus caricinus</i>
Carey's balsamroot	<i>Balsamorhiza careyana</i>
Cusick's sunflower	<i>Helianthus cusickii</i>
cutleaf ladysfoot mustard	<i>Thelypodium laciniatum</i>
Douglas' clusterlily	<i>Brodiaea douglasii</i>
dune scurfpea	<i>Psoralea lanceolata</i>
Franklin's sandwort	<i>Arenaria franklinii</i>
Gray's desertparsley	<i>Lomatium grayi</i>
hoary aster	<i>Machaeranthera canescens</i>
hoary falseyarrow	<i>Chaenactis douglasii</i>
longleaf phlox	<i>Phlox longifolia</i>

**Table 4.11.** (contd)

<b>A. Shrub-Steppe Species</b>	<b>Scientific Name</b>
<b>Perennial Forbs (cont)</b>	
Munro's globemallow	<i>Sphaeralcea munroana</i>
pale evening primrose	<i>Oenothera pallida</i>
sand beardtongue	<i>Penstemon acuminatus</i>
stalked-pod milkvetch	<i>Astragalus sclerocarpus</i>
threadleaf fleabane	<i>Erigeron filifolius</i>
turpentine spring parsley	<i>Cymopterus terebinthinus</i>
winged dock	<i>Rumex venosus</i>
yarrow	<i>Achillea millefolium</i>
yellow bell	<i>Fritillaria pudica</i>
<b>Annual Forbs</b>	
annual Jacob's ladder	<i>Polemonium micranthum</i>
blue mustard	<i>Chorispora tenella</i> <sup>(a)</sup>
bur ragweed	<i>Ambrosia acanthicarpa</i>
clasping pepperweed	<i>Lepidium perfoliatum</i>
indian wheat	<i>Plantago patagonica</i>
jagged chickweed	<i>Holosteum umbellatum</i> <sup>(a)</sup>
Jim Hill's tumbledustard	<i>Sisymbrium altissimum</i> <sup>(a)</sup>
matted cryptantha	<i>Cryptantha circumscissa</i>
pink microsteris	<i>Microsteris gracilis</i>
prickly lettuce	<i>Lactuca serriola</i> <sup>(a)</sup>
rough wallflower	<i>Erysimum asperum</i>
Russian thistle (tumbleweed)	<i>Salsola kali</i> <sup>(a)</sup>
slender hawkbeard	<i>Crepis atrabarba</i>
spring whitlowgrass	<i>Draba verna</i> <sup>(a)</sup>
storksbill	<i>Erodium cicutarium</i> <sup>(a)</sup>
tall willowherb	<i>Epilobium paniculatum</i>
tarweed fiddleneck	<i>Amsinckia lycopsoides</i>
threadleaf scorpion weed	<i>Phacelia linearis</i>

**Table 4.11.** (contd)

<b>A. Shrub-Steppe Species</b>	<b>Scientific Name</b>
<b>Annual Forbs (contd)</b>	
western tansymustard	<i>Descurainia pinnata</i>
white cupseed	<i>Plectritis macrocera</i>
whitestem stickleaf	<i>Mentzelia albicaulis</i>
winged cryptantha	<i>Cryptantha pterocarya</i>
yellow salsify	<i>Tragopogon dubius</i> <sup>(a)</sup>
<b>Annual Grasses</b>	
cheatgrass	<i>Bromus tectorum</i> <sup>(a)</sup>
slender sixweeks	<i>Festuca octoflora</i>
small sixweeks	<i>Festuca microstachys</i>
<b>Trees and Shrubs</b>	
black cottonwood	<i>Populus trichocarpa</i>
black locust	<i>Robinia pseudo-acacia</i>
coyote willow	<i>Salix exigua</i>
dogbane	<i>Apocynum cannabinum</i>
peach, apricot, cherry	<i>Prunus</i> spp.
peachleaf willow	<i>Salix amygdaloides</i>
willow	<i>Salix</i> spp.
white mulberry	<i>Morus alba</i> <sup>(a)</sup>
<b>B. Riparian Species</b>	<b>Scientific Name</b>
<b>Perennial Grasses and Forbs</b>	
bentgrass	<i>Agrostis</i> spp. <sup>(b)</sup>
blanket flower	<i>Gaillardia aristata</i>
bulrushes	<i>Scirpus</i> spp. <sup>(b)</sup>
cattail	<i>Typha latifolia</i> <sup>(b)</sup>
Columbia River gumweed	<i>Grindelia columbiana</i>
hairy golden aster	<i>Heterotheca villosa</i>
heartweed	<i>Polygonum persicaria</i>
horsetails	<i>Equisetum</i> spp.

**Table 4.11.** (contd)

<b>B. Riparian Species</b>	<b>Scientific Name</b>
Perennial Grasses and Forbs (contd)	
horseweed tickseed	<i>Coreopsis atkinsoniana</i>
lovegrass	<i>Eragrostis</i> spp. <sup>(b)</sup>
lupine	<i>Lupinus</i> spp.
meadow foxtail	<i>Alopecurus aequalis</i> <sup>(b)</sup>
Pacific sage	<i>Artemisia campestris</i>
prairie sagebrush	<i>Artemisia ludoviciana</i>
reed canary grass	<i>Phalaris arundinacea</i> <sup>(b)</sup>
rushes	<i>Juncus</i> spp.
Russian knapweed	<i>Centaurea repens</i> <sup>(a)</sup>
sedge	<i>Carex</i> spp. <sup>(b)</sup>
water speedwell	<i>Veronica anagallis-aquatica</i>
western goldenrod	<i>Solidago occidentalis</i>
wild onion	<i>Allium</i> spp.
wiregrass spikerush	<i>Eleocharis</i> spp. <sup>(b)</sup>
Aquatic Vascular	
Canadian waterweed	<i>Elodea Canadensis</i>
Columbia yellowcress	<i>Rorippa columbiae</i>
duckweed	<i>Lemna minor</i>
pondweed	<i>Potamogeton</i> spp.
spiked water milfoil	<i>Myriophyllum spicatum</i>
watercress	<i>Rorippa nasturtium-aquaticum</i>
(a) Introduced.	
(b) Perennial grasses and graminoids.	

**200 Areas Flora.** Waste management areas and crib sites are generally either barren or vegetated by invasive species, including Russian thistle (tumbleweed), tumble mustard, and cheatgrass. Russian thistle and gray rabbitbrush occurring in these areas are deep rooted and have the potential to accumulate radionuclides and other buried contaminants, functioning as a pathway to other parts of the ecosystem (Landeen et al. 1993). Russian thistle, an annual weed, accumulates nitrates and soluble oxalates, and has significant seed dispersion. Vegetation samples are collected annually from the 200/600 Areas and analyzed for uranium, cobalt-60, strontium-90, cesium-137, and plutonium-239/240. The Hanford Integrated Biological Control (IBC) program was established to control the growth of deep-rooted vegetation over contaminated and potentially contaminated waste sites. The program also established vegetation control through herbicide spraying and cleanup activities. The effectiveness of the program is directly related to the timeliness of herbicide application and removal of tumbleweeds, rabbitbrush, and sagebrush.

The portions of the 200 Areas undisturbed by DOE and its predecessor agencies, but previously disturbed by farmers and ranchers, are characterized as sagebrush/cheatgrass or Sandberg's bluegrass communities of the 200 Area Plateau. Cheatgrass provides half of the total plant cover. Most of the waste disposal and storage sites are covered by nonnative vegetation or are kept in a vegetation-free condition with the use of herbicides, because the plants could potentially accumulate waste constituents. Figures 4.22 and 4.23 illustrate existing vegetation and land use areas mapped prior to the *24 Command Fire* for the 200 West Area and 200 East Area, respectively. Early observations suggest the soil structure and seed bank may have been damaged to the point where vegetative recovery will be slower than in other areas, and the resulting community may not resemble the sagebrush-steppe that existed before the fire.

West Lake and its immediate basin represent a unique habitat that is characterized by highly saline conditions (Poston et al. 1991). Water levels of the pond fluctuate with groundwater levels. Predominant plants include salt grass, plantain, and rattlebox. Three-spine bulrush grows along the shoreline.

#### **4.6.2 Wildlife**

Three hundred species of terrestrial vertebrates have been observed on the Hanford Site. The species list includes approximately 42 species of mammals, 246 species of birds, 5 species of amphibians, and 12 species of reptiles (Soll and Soper 1996; Brandt et al. 1993).

The shrub and grassland habitat of the Hanford Site supports many groups of terrestrial wildlife. Species include large game animals like Rocky Mountain elk and mule deer; predators such as coyote, bobcat, and badger; and herbivores like deer mice, harvest mice, ground squirrels, voles, and black-tailed jackrabbits. The most abundant mammal on the Hanford Site is the Great Basin pocket mouse.

Mule deer rely on shoreline vegetation and bitterbrush shrubs for browse (Tiller et al. 1997). Elk, which are more dependent on open grasslands for forage, seek the cover of sagebrush and other shrub species during the summer months. Elk first appeared on the Hanford Site in 1972 (Fitzner and Gray 1991), and have increased from approximately eight animals in 1975 to 900 in 1999. The Rattlesnake Hills elk herd that inhabits the Hanford Site primarily occupies ALE and private lands that adjoin the reserve to the north and west. Elk are occasionally seen on the 200 Area Plateau and have been sighted at the White Bluffs boat launch on the Hanford Site. The herd tends to congregate on ALE in the winter and disperses during the summer months to higher elevations on ALE, private land to the west of ALE, and the U.S. Army Yakima Training Center. Approximately 300 elk have been relocated or removed by special hunts during 1999-2000. Elk relocation continued in 2002. The *24 Command Fire* in June 2000 destroyed nearly all the elk forage on ALE. The herd moved onto unburned private land west of the site, to unburned areas on central Hanford, and along the Columbia River near the 100-B/C and 100-K Areas. Post-fire surveys suggest very low mortality of adult elk as a result of the wildfire.

However, the wildfire occurred in the middle of calving season, which may have an impact on the number of calves and their survival to adulthood. A cougar sighting on ALE was reported during the elk relocation effort in March 2000.

Shrubland and grassland provide nesting and foraging habitat for many passerine bird species. Surveys conducted during 1993 (Cadwell 1994) reported the occurrence of western meadowlarks and horned larks more frequently in shrubland habitats than in other habitats on the site. TNC (1999) reported a total of 41 species that are considered dependent on steppe or shrub-steppe habitat. Long-billed curlews and vesper sparrows were also noted as commonly occurring species in shrubland habitat. Species that are dependent on undisturbed shrub habitat include sage sparrow, sage thrasher, and loggerhead shrike. The sage sparrow and loggerhead shrike tend to roost and nest in sagebrush or bitterbrush that occurs at lower elevations (DOE-RL 2001). Ground-nesting species that occur in grass-covered uplands include long-billed curlews, western meadowlark, and burrowing owls.

Common upland game bird species that occur in shrub and grassland habitat include chukar partridge, California quail, and Chinese ring-necked pheasant. Chukars are most numerous in the Rattlesnake Hills, Yakima Ridge, Umtanum Ridge, Saddle Mountains, and Gable Mountain areas of the Hanford Site. Less common species include western sage grouse, Hungarian partridge, and scaled quail. Western sage grouse were historically abundant on the Hanford Site. However, populations have declined since the early 1800s because of the conversion of sagebrush-steppe habitat. Surveys conducted by the Washington State Department of Fish and Wildlife (WDFW) and PNNL during late winter and early spring 1993, and biodiversity inventories conducted by The Nature Conservancy in 1997, did not observe western sage grouse in sagebrush-steppe habitat at ALE. However, sage grouse have been observed on ALE in 1999 and 2000 (Tiller 2000).

Among the raptor species that use shrubland and grassland habitats are American kestrel, red-tailed hawk, Swainson's hawk, and ferruginous hawks. Northern harriers, sharp-shinned hawks, rough-legged hawks, and golden eagles also occur in these habitats but are not sighted as frequently. In 1994, nesting by red-tailed, Swainson's, and ferruginous hawks included 41 nests located across the Hanford Site on high voltage transmission towers, trees, cliffs, and basalt outcrops. In recent years, the number of nesting ferruginous hawks on the Hanford Site has increased, in part as a result of their acceptance of steel power line towers in the open grass and shrubland habitats.

Many species of insects occur throughout all habitats on the Hanford Site. Butterflies, grasshoppers, and darkling beetles are among the most conspicuous of the approximately 1500 species of insects that have been identified from specimens collected on the Hanford Site (TNC 1999). The actual number of insect species occurring on the Hanford Site may reach as high as 15,500. A total of 1509 species-level identifications were completed in 1999 and 500 more are expected. Recent surveys performed by The Nature Conservancy included the collection of 40,000 specimens and have resulted in the identification of 43 new taxa and 142 new findings in the state of Washington (TMC 1999). The high diversity of insect species on the Hanford Site is believed to reflect the size, complexity, and quality of the shrub-steppe habitat.



The side-blotched lizard is the most abundant reptile species that occurs on the Hanford Site. Sagebrush lizards and short-horned lizards are reportedly found on the site, but occur infrequently. The most common snake species include gopher snake, yellow-bellied racer, and Pacific rattlesnake. The Great Basin spadefoot toad, Woodhouse's toad, Pacific tree frog, tiger salamander, and bullfrog are the only amphibians found on the site (TNC 1999; Brandt et al. 1993).

With the cessation of production activities at Hanford, the amount of water discharged to the ground in the 200 Area Plateau has substantially decreased. West Lake has shrunk and is presently a group of small isolated pools and mud flats. Avocets and sandpipers still use the site, but it does not support coots or other nesting waterfowl.

### **4.6.3 Aquatic Ecology**

Two types of natural aquatic habitats are found on the Hanford Site: the Columbia River that flows along the northern and eastern edges of the site, and the small spring-streams and seeps located mainly on ALE in the Rattlesnake Hills.

The Columbia River is the dominant aquatic ecosystem on the Hanford Site and supports a large and diverse community of plankton, benthic invertebrates, fish, and other communities. It has a drainage area of about 680,000 km<sup>2</sup> (260,000 mi<sup>2</sup>), an estimated average annual discharge of 6600 m<sup>3</sup>/s (71,000 ft<sup>3</sup>/s), and a total length of about 2000 km (1240 mi) from its origin in British Columbia to its mouth at the Pacific Ocean. The Columbia has been dammed upstream and downstream of the Hanford Site, and the Hanford Reach flowing through the site is the last free-flowing, but regulated, section of the Columbia River in the United States above Bonneville Dam. Plankton populations in the Hanford Reach are influenced by communities that develop in the reservoirs of upstream dams, particularly Priest Rapids Reservoir, and by manipulation of water levels below by dam operations in upstream and downstream reservoirs. Phytoplankton and zooplankton populations provide food for herbivores such as immature insects that are then consumed by predaceous species. These phytoplankton and zooplankton are largely transient, flowing from one reservoir to another. There is generally insufficient time for characteristic endemic groups of phytoplankton and zooplankton to develop in the Hanford Reach. No tributaries enter the Columbia River during its passage through the Hanford Site; however, there are several irrigation water return canals that discharge into the river along the Franklin County shoreline.

Gray and Dauble (1977) listed 43 species of fish in the Hanford Reach of the Columbia River. The brown bullhead, collected since 1977, brings the total number of fish species identified in the Hanford Reach to 44. Of these species, Chinook salmon, sockeye salmon, coho salmon, and steelhead trout use the river as a migration route to and from upstream spawning areas and are of the greatest economic importance. Additionally, fall Chinook salmon and steelhead trout spawn in the Hanford Reach.

Small interrupted streams, such as Rattlesnake and Snively springs, contain diverse biotic communities and are extremely productive (Cushing and Wolf 1984). Dense blooms of watercress occur and aquatic insect production is high compared with mountain streams (Gaines 1987). The macrobenthic biota varies from stream to stream and is related to the proximity of colonizing insects and other factors. Rattlesnake Springs is of ecological importance because it provides a source of water to terrestrial

animals in an otherwise arid part of the site. Snively Springs, located farther west and at a higher elevation than Rattlesnake Springs, is a source of drinking water for terrestrial animals. The major rooted aquatic plant, which in places may cover the entire width of the stream, is watercress (*Rorippa nasturtium-aquaticum*). Isolated patches of bulrush (*Scirpus* sp.), spike rush (*Eleocharis* sp.), and cattail (*Typha latifolia*) occupy less than 5 percent of the streambed.

#### 4.6.4 Threatened and Endangered Species

The federal Endangered Species Act (16 USC 1531-1544) defines endangered species as plants and animals in danger of extinction within the foreseeable future throughout all or a significant portion of its range. Threatened species are those likely to become endangered within the foreseeable future throughout all or a significant portion of its range. Candidate species are plants and animals with a status of concern, but more information is needed before they can be proposed for listing.

No plants or mammals on the federal list of threatened and endangered wildlife and plants (50 CFR 17) are known to occur on the Hanford Site. However, the bald eagle and two species of fish (steelhead and spring-run Chinook salmon), currently found on the federal list of threatened and endangered species, are present on the Hanford Site on a regular basis. Surveys of the 200 Areas (Sackschewsky 2002, 2003) and Area C (Sackschewsky 2003) revealed no federal or state threatened or endangered species (see Appendix I).

Federally listed threatened, endangered, candidate species (50 CFR 17), and species of concern ([http://www.wa.gov/wdfw/wlm/diversty/soc/adv\\_search.htm](http://www.wa.gov/wdfw/wlm/diversty/soc/adv_search.htm)) and threatened and endangered species listed by Washington State (Washington Natural Heritage Program 2002) identified on the Hanford Site are shown in Table 4.12. Several candidate species of plants and animals are under consideration for formal listing by the federal government and Washington State. The FWS annually reviews the status of candidate species for listing under the Endangered Species Act. The results of these reviews are posted on the FWS homepage <http://www.fws.gov>. Several federal plant and animal species of concern require further information before the FWS can decide whether the species should be considered for formal listing ([http://www.wa.gov/wdfw/wlm/diversty/soc/adv\\_search.htm](http://www.wa.gov/wdfw/wlm/diversty/soc/adv_search.htm)). Anadromous fish are reviewed and listed by the National Marine Fisheries Service (NMFS) (<http://www.nwr.noaa.gov>).

Washington State defines endangered species as wildlife species native to the state of Washington that are seriously threatened with extinction throughout all or a significant portion of their ranges within the state. Threatened species include wildlife species native to the state that are likely to become an endangered species within the foreseeable future throughout a significant portion of their ranges within the state (WAC 232-12-297). A State of Washington sensitive species is a wildlife species native to the state that is vulnerable or declining and is likely to become endangered or threatened throughout a significant portion of its range within the state without cooperative management or removal of threats. The common loon (*Gavia immer*) is the only Washington State sensitive animal species found on the Hanford Site. Table 4.13 lists the Washington State-designated candidate animal species that potentially are found on the Hanford Site and are under consideration for possible addition to the threatened or endangered list. A state candidate species is one that is being reviewed for possible listing as a state endangered, threatened, or sensitive species as specified in Washington Department of Fish and Wildlife Policy M-6001 (WDFW 1998).

**Table 4.12.** Federally Listed Threatened, Endangered, Candidate Species, and Species of Concern and Washington State-Listed Threatened and Endangered Species Occurring or Potentially Occurring on the Hanford Site (Fitzner and Gray 1991, Landeen et al. 1992, FWS 2003, and Neitzel 2002a)

Common Name	Scientific Name	Federal	State <sup>(a)</sup>
<b>Plants</b>			
Columbia milkvetch	<i>Astragalus columbianus</i>	SC <sup>(b)</sup>	T <sup>(c)</sup>
dwarf evening primrose	Camissonia (= Oenothera) pygmaea		T
Hoover's desert parsley	Lomatium tuberosum	SC	T
Loeflingia	Loeflingia squarrosa var. squarrosa		T
persistent sepal yellowcress	Rorippa columbiae	SC	T
Umtanum desert (wild) buckwheat	Eriogonum codium	C <sup>(d)</sup>	E <sup>(e)</sup>
White Bluffs bladderpod	Lesquerella tuplashensis	C	E
white eatonella	Eatonella nivea		T
Ute ladies'-tresses <sup>(g)</sup>	<i>Spiranthes diluvialis</i>	T	
<b>Fish</b>			
bull trout <sup>(g)</sup>	<i>Salvelinus confluentus</i>	T	
spring-run Chinook	Oncorhynchus tshawytscha	E	C
Upper Columbia steelhead	Oncorhynchus mykiss	E	C
Middle Columbia steelhead	<i>Oncorhynchus mykiss</i>	T	C
<b>Birds</b>			
American white pelican	Pelecanus erythrorhychos		E
bald eagle <sup>(f)</sup>	Haliaeetus leucocephalus	T	T
ferruginous hawk	Buteo regalis	SC	T
greater sage grouse	<i>Centrocercus urophasianus phaios</i>	C	T
olive-sided flycatcher	<i>Contopus cooperi</i>	SC	
sandhill crane	Grus canadensis		E
willow flycatcher	<i>Empidonax trailii</i>	SC	
yellow-billed cuckoo <sup>(g)</sup>	<i>Coccyzus americanus</i>	C	
<b>Reptiles</b>			
Northern sagebrush lizard	<i>Sceloporous graciosus</i>	SC	
(a) <a href="http://www.wa.gov/wdfw/selectHabitat.PriorityEngineeringandSpeciesList.SpeciesofConcernList.EndangeredSpecies(WAC232-12-297)">http://www.wa.gov/wdfw/ select Habitat, Priority Habitats and Species List, Species of Concern List, Endangered Species (WAC 232-12-297)</a> (b) SC = Federal species of concern, 50 CFR 17 <a href="http://www.fws.gov">http://www.fws.gov</a> . (c) T = Federal threatened species, 50 CFR 17 <a href="http://www.fws.gov">http://www.fws.gov</a> . (d) C = Federal candidate species, 50 CFR 17 <a href="http://www.fws.gov">http://www.fws.gov</a> . (e) E = Federal endangered species, 50 CFR 17 <a href="http://www.fws.gov">http://www.fws.gov</a> . (f) Currently under review for change in status. (g) Not believed present on the Hanford Site, but identified by FWS 2003.			

**Table 4.13.** Washington State Candidate Animal Species Found on the Hanford Site (Fitzner and Gray 1991; Landeen et al. 1992; and Neitzel 2002a)

Common Name	Scientific Name
<b>Molluscs</b>	
giant Columbia River spire snail <sup>(a,b)</sup>	<i>Fluminicola (= Lithoglyphus) columbiana</i>
giant Columbia River limpet	<i>Fisherola (= Lanx) nuttalli</i>
<b>Fish</b>	
spring-run Chinook <sup>(c)</sup>	<i>Oncorhynchus tshawytscha</i>
steelhead <sup>(b)</sup>	<i>Oncorhynchus mykiss</i>
<b>Insects</b>	
Columbia River tiger beetle <sup>(d)</sup>	<i>Cicindela columbica</i>
<b>Birds</b>	
burrowing owl <sup>(a,b)</sup>	<i>Athene cunicularia</i>
golden eagle	<i>Aquila chrysaetos</i>
Lewis' woodpecker	<i>Melanerpes lewis</i>
loggerhead shrike <sup>(a,b)</sup>	<i>Lanius ludovicianus</i>
merlin	<i>Falco columbarius</i>
northern goshawk <sup>(a,b,e)</sup>	<i>Accipiter gentilis</i>
sage sparrow	<i>Amphispiza belli</i>
sage thrasher	<i>Preoscotes montanus</i>
Vaux's swift	<i>Chaetura vauxi</i>
<b>Reptiles</b>	
striped whipsnake	<i>Masticophis taeniatus</i>
<b>Mammals</b>	
black-tailed jackrabbit	<i>Lepus californicus</i>
Merriam's shrew	<i>Sorex merriami</i>
Washington ground squirrel <sup>(f)</sup>	<i>Spermophilus washingtoni</i>
white-tailed jackrabbit	<i>Lepus townsendi</i>
(a) Information from Washington Department of Fish and Wildlife <a href="http://www.wa.gov/wdfw/">http://www.wa.gov/wdfw/</a> select Habitat, Priority Habitats and Species List, Species of Concern List (WDFW Policy M-6001 1988). (b) Federal endangered. (c) Probable, but not observed on the Hanford Site. (d) Reported, but seldom observed on the Hanford Site. (e) Federal candidate.	

Washington State considers shrub-steppe habitat as a priority habitat because of its relative scarcity in the state and because of its requirement as nesting/breeding habitat by several state and federal species of concern (see Figure 4.21 for vegetation habitat coverage). Designation and characterization of priority habitat serves to provide a basis for sound and defensible land management planning and assists the DOE in implementing sound stewardship activities into site management to protect regulated species.

Table 4.14 lists Washington State plant species of concern that are currently listed as sensitive or are in one of three monitored groups (Washington Natural Heritage Program 2002; TNC 1999). The

Washington Natural Heritage Program established the ratings reported in Table 4.14 as Sensitive (vulnerable or declining and could become endangered or threatened), Review 1 (more field work needed), and Review 2 (unresolved taxonomic problems).

Figure 4.24 shows the general locations of species of concern on the Hanford Site prior to the wildfire, and the 24 Command Fire coverage. In some areas the wildfire burn intensity was generally low, allowing belowground portions of some perennial plants and seeds to survive. However, there were some areas of high burn where the soil and seed bank may have been damaged. Most of the rare plants are expected to recover within 1 to 3 years, although their populations may be reduced.

**200 Areas.** The annual review of the LLBGs was conducted in April of 2001 (Sackschewsky 2002). Due to access restrictions, visual observations from the burial ground perimeters were performed. The LLBGs include 218-E-10 and 218-E-12B in the 200 East Area, and 218-W-3A, 218-W-3AE, 218-W-4B, 218-W-4C, 218-W-5, and 218-W-6 in the 200 West Area. The western half of 218-W-6, the undeveloped portion of 218-W-4C (along 16<sup>th</sup> Street), and the undeveloped portion of the 218-E-10 Burial Ground (north of the existing powerline) were not reviewed during recent evaluations.

Crouching milkvetch (*Astragalus succumbens*) and stalked-pod milkvetch (*Astragalus sclerocarpus*), State of Washington watch list species, were observed within the 218-W-4C Burial Ground and the extreme western edge of the 218-W-5 Burial Ground. Crouching milkvetch was also observed in the south end of the 218-W-6 Burial Ground. Piper's daisy (*Erigeron piperianus*), a State of Washington sensitive species was noted in the 218-E-12B and 218-E-10 Burial Grounds in previous years.

Birds observed within the 200 East Area LLBGs include long-billed curlews (*Numenius americanus*), killdeer (*Charadrius viociferus*), horned larks (*Eremophila alpestris*), Say's phoebe (*Sayornis saya*), American robin (*Turdus migratorius*), American kestrel (*Falco sparverius*), western meadowlark (*Sturnella neglecta*), and common raven (*Corvus corax*). Two bird species, loggerhead shrike (*Lanius ludovicianus*) and sage sparrow (*Amphispiza belli*), Washington State candidate species, have been sighted in the vicinity of the 218-W-4C Burial Ground. Burrowing owls (*Athene cunicularia*), Washington State candidate species, have been observed in the vicinity of the 218-W-6 Burial Ground.

A 1998 amendment to the Fish and Conservation Act directs the FWS to identify species, subspecies, and populations of all migratory non-game birds that, without additional conservation actions, are likely to become candidates for listing under the Endangered Species Act (FWS 2002). These birds, designated as Birds of Conservation Concern, also include recently delisted species. Table 4.15 lists Birds of Conservation Concern, as recognized by the FWS, which have been observed on the Hanford Site.

**Table 4.14.** Washington State Plant Species of Concern Occurring on the Hanford Site, as Determined by the Washington Natural Heritage Program 2002 (Neitzel 2002a)

Common Name	Scientific Name	State Listing
annual paintbrush	<i>Castilleja exilis</i>	R1
awned halfchaff sedge	<i>Lipocarpa (= Hemicarpha) aristulata</i>	R1
basalt milk-vetch	<i>Astragalus conjunctus</i> var. <i>rickardii</i>	R1
bristly combseed	<i>Pectocarya setosa</i>	W
brittle prickly pear	<i>Opuntia fragilis</i>	R1
Canadian St. John's wort	<i>Hypericum majus</i>	S
chaffweed	<i>Centunculus minimus</i>	R1
Columbia River mugwort	<i>Artemisia lindleyana</i>	W
coyote tobacco	<i>Nicotiana attenuata</i>	S
crouching milkvetch	<i>Astragalus succumbens</i>	W
desert dodder	<i>Cuscuta denticulata</i>	S
desert evening-primrose	<i>Oenothera caespitosa</i>	S
false pimpernel	<i>Lindernia dubia anagallidea</i>	R2
fuzzytongue penstemon	<i>Penstemon eriantherus whitedii</i>	R1
Geyer's milkvetch	<i>Astragalus geyeri</i>	S
grand redstem	<i>Ammannia robusta</i>	R1
gray cryptantha	<i>Cryptantha leucophaea</i>	S
Great Basin gilia	<i>Gilia leptomeria</i>	R1
hedge hog cactus	<i>Pediocactus simpsonii</i> var. <i>robustior</i>	R1
Kittitas larkspur	<i>Delphinium multiplex</i>	W
lowland toothcup	<i>Rotala ramosior</i>	R1
miner's candle	<i>Cryptantha scoparia</i>	R1
Piper's daisy	<i>Erigeron piperianus</i>	S
Robinson's onion	<i>Allium robinsonii</i>	W
rosy balsamroot	<i>Balsamorhiza rosea</i>	W
rosy pussypaws	<i>Calyptridium roseum</i>	S
scilla onion	<i>Allium scilloides</i>	W
shining flatsedge	<i>Cyperus bipartitus (rivularis)</i>	S
small-flowered evening-primrose	<i>Camissonia (= Oenothera) minor</i>	R1
small-flowered nama	<i>Nama densum</i> var. <i>parviflorum</i>	R1
smooth cliffbrake	<i>Pellaea glabella simplex</i>	W
Snake River cryptantha	<i>Cryptantha spiculifera (= C. interrupta)</i>	S
southern mudwort	<i>Limosella acaulis</i>	W
stalked-pod milkvetch	<i>Astragalus sclerocarpus</i>	W
Suksdorf's monkey flower	<i>Mimulus suksdorfii</i>	S
winged combseed	<i>Pectocarya linearis</i>	R1
The following species have been reported as occurring on the Hanford Site, but the known collections are questionable in terms of location or identification, and have not been collected recently on the site.		
Beaked spike-rush	<i>Eleocharis rostellata</i>	S
dense sedge	<i>Carex densa</i>	S
few-flowered collinsia	<i>Collinsia sparsiflora</i> var. <i>bruciaea</i>	S
giant helleborine	<i>Epipactis gigantea</i>	S
medic milkvetch	<i>Astragalus speirocarpus</i>	W
orange balsam	<i>Impatiens aurella</i>	R2
Palouse milkvetch	<i>Astragalus arrectus</i>	S
Palouse thistle	<i>Cirsium brevifolium</i>	W
porcupine sedge	<i>Carex hystericina</i>	S
Thompson's sandwort	<i>Arenaria franklinii thompsonii</i>	R2
S = Sensitive (i.e., taxa vulnerable or declining) and could become endangered or threatened without active management or removal of threats.		
R1 = Taxa for which there are insufficient data to support listing as threatened, endangered, or sensitive (formerly monitor group 1).		
R2 = Taxa with unresolved taxonomic questions (formerly monitor group 2).		
W = Taxa that are more abundant or less threatened than previously assumed (formerly monitor group 3).		

**Table 4.15.** Birds of Conservation Concern Observed on the Hanford Site (FWS 2002).

Common Name	Scientific Name
Swainson's hawk	<i>Buteo swainsoni</i>
ferruginous hawk	<i>Buteo regalis</i>
golden eagle	<i>Aquila chrysaetos</i>
peregrine falcon	<i>Falco peregrinus</i>
prairie falcon	<i>Falco mexicanus</i>
grasshopper sparrow	<i>Ammodramus savannarum</i>
greater sage grouse (a)	<i>Centrocercus urophasianus phaios</i>
American avocet	<i>Recurvirostra americana</i>
solitary sandpiper	<i>Tringa solitaria</i>
long-billed curlew	<i>Numenius americanus</i>
marbled godwit	<i>Limosa fedoa</i>
sanderling	<i>Calidris alba</i>
Wilson's phalarope	<i>Phalaropus tricolor</i>
flamulated owl	<i>Otus flammeolus</i>
burrowing owl	<i>Athene cunicularia</i>
Lewis' woodpecker	<i>Melanerpes lewis</i>
loggerhead shrike	<i>Lanius ludovicianus</i>
Brewer's sparrow	<i>Spizella breweri</i>
sage sparrow	<i>Amphispiza belli</i>
sage thrasher	<i>Oreoscoptes montanus</i>

(a) Endangered Species Act candidate.

#### 4.6.5 Microbiotic Crusts

Microbiotic crusts generally occur in the top 1 to 4 mm (0.04 to 0.16 in.) of soil and are formed by living organisms and their by-products, creating a crust of soil particles bound together by organic materials. Microbiotic crusts are common in the semiarid Columbia Basin, where the dominant form tends to be green algae (Johansen et al. 1993). The functions of microbiotic crusts include soil stability and protection from erosion, fixation of atmospheric nitrogen, nutrient contribution to plants, influencing soil-plant water relations, increasing water infiltration, seedling germination, and plant growth. The ecological roles of microbiotic crusts depend on the relative cover of various crustal components. Carbon inputs are higher when mosses and lichens are present than when the crust is dominated by cyanobacteria. Nitrogen inputs are higher with greater water infiltration. Soil surface stability is related to cyanobacterial biomass as well as total moss and lichen cover (Belnap et al. 2001). The lichen and mosses of the Hanford Site were surveyed and evaluated by Link et al. (2000). They found 29 soil lichens in 19 genera and 6 moss species in 4 genera. Twelve (41 percent) lichen species are of the crustose growth form (flat and firmly attached to the substrate), eight (28 percent) are squamulose (having small, flat scales that do

not adhere tightly to substrate), seven (24 percent) are foliose (having leaf-like lobes, attached in the center to substrate by clusters of rhizomes) and two (7 percent) are fruticose (plant-like growth attached at one point).

#### **4.6.6 Biodiversity**

The Hanford Site is located within the Columbia Basin Ecoregion, an area that historically included over 6 million ha (14.8 million ac) of steppe and shrub-steppe vegetation across most of central and southeastern Washington state, as well as portions of north-central Oregon. The pre-settlement vegetation consisted primarily of shrubs, perennial bunchgrasses, and a variety of forbs. An estimated 60 percent of shrub-steppe in Washington has been converted to agriculture or other uses. Much of what remains is in small parcels, in shallow rocky soils, or has been degraded by historic land uses (mostly livestock grazing) (TNC 1999).

The Hanford Site retains some of the largest remaining blocks of relatively undisturbed shrub-steppe in the Columbia Basin Ecoregion. Hanford's importance as a refuge for the shrub-steppe ecosystem is not solely size-related, however. The presence of a high diversity of physical features and examples of rare, undeveloped deep and sandy soil has led to a corresponding diversity of plant and animal communities. Many places on the Hanford Site are relatively free of non-native species and are extensive enough to retain characteristic populations of shrub-steppe plants and animals that are absent or scarce in other areas. Because of its location, the site provides important connectivity with other undeveloped portions of the ecoregion.

### **4.7 Cultural, Archaeological, and Historical Resources**

The Hanford vicinity is one of the most culturally rich resource areas in the western Columbia Plateau. The site consists of a series of cultural landscapes containing the cumulative record of multiple occupations by Native and non-Native Americans. These landscapes contain numerous well-preserved archaeological sites representing prehistoric, ethnographic, and historic periods. Period resources include sites with cultural materials that are thousands of years old, traditional cultural places, and buildings and structures from the pre-Hanford, Manhattan Project, and Cold War eras. The National Historic Preservation Act (16 USC 470), the Native American Graves Protection and Repatriation Act (25 USC 3001 et seq.), the Archaeological Resources Protection Act (16 USC 469 et seq.), and the DOE American Indian Policy (DOE 2000), among other legislation and guidelines, require the identification and protection of areas and resources of concern to the Native American community (see Sections 6.13 and 6.14).

#### **4.7.1 Native American Cultural Resources and Archaeological Resources**

Traditional Native American religion is manifest in the earth, the water, the sky, and all animate or inanimate beings that inhabit a given location. In prehistoric and early historic times, Native Americans of various tribal affiliations populated the Hanford Reach of the Columbia River. The Wanapum and the Chamnapum dwelt along the Columbia River from south of Richland upstream to Vantage (Relander 1956; Spier 1936). Some of their descendants (Wanapum) still live nearby at Priest Rapids;



not adhere tightly to substrate), seven (24 percent) are foliose (having leaf-like lobes, attached in the center to substrate by clusters of rhizomes) and two (7 percent) are fruticose (plant-like growth attached at one point).

#### **4.6.6 Biodiversity**

The Hanford Site is located within the Columbia Basin Ecoregion, an area that historically included over 6 million ha (14.8 million ac) of steppe and shrub-steppe vegetation across most of central and southeastern Washington state, as well as portions of north-central Oregon. The pre-settlement vegetation consisted primarily of shrubs, perennial bunchgrasses, and a variety of forbs. An estimated 60 percent of shrub-steppe in Washington has been converted to agriculture or other uses. Much of what remains is in small parcels, in shallow rocky soils, or has been degraded by historic land uses (mostly livestock grazing) (TNC 1999).

The Hanford Site retains some of the largest remaining blocks of relatively undisturbed shrub-steppe in the Columbia Basin Ecoregion. Hanford's importance as a refuge for the shrub-steppe ecosystem is not solely size-related, however. The presence of a high diversity of physical features and examples of rare, undeveloped deep and sandy soil has led to a corresponding diversity of plant and animal communities. Many places on the Hanford Site are relatively free of non-native species and are extensive enough to retain characteristic populations of shrub-steppe plants and animals that are absent or scarce in other areas. Because of its location, the site provides important connectivity with other undeveloped portions of the ecoregion.

### **4.7 Cultural, Archaeological, and Historical Resources**

The Hanford vicinity is one of the most culturally rich resource areas in the western Columbia Plateau. The site consists of a series of cultural landscapes containing the cumulative record of multiple occupations by Native and non-Native Americans. These landscapes contain numerous well-preserved archaeological sites representing prehistoric, ethnographic, and historic periods. Period resources include sites with cultural materials that are thousands of years old, traditional cultural places, and buildings and structures from the pre-Hanford, Manhattan Project, and Cold War eras. The National Historic Preservation Act (16 USC 470), the Native American Graves Protection and Repatriation Act (25 USC 3001 et seq.), the Archaeological Resources Protection Act (16 USC 469 et seq.), and the DOE American Indian Policy (DOE 2000), among other legislation and guidelines, require the identification and protection of areas and resources of concern to the Native American community (see Sections 6.13 and 6.14).

#### **4.7.1 Native American Cultural Resources and Archaeological Resources**

Traditional Native American religion is manifest in the earth, the water, the sky, and all animate or inanimate beings that inhabit a given location. In prehistoric and early historic times, Native Americans of various tribal affiliations populated the Hanford Reach of the Columbia River. The Wanapum and the Chamnapum dwelt along the Columbia River from south of Richland upstream to Vantage (Relander 1956; Spier 1936). Some of their descendants (Wanapum) still live nearby at Priest Rapids;

others live on the Yakama and Umatilla Reservations. Palus people, who lived on the lower Snake River, joined the Wanapum and Chamnapum to fish the Hanford Reach of the Columbia River and some inhabited the east bank of the river (Relander 1956; Trafzer and Scheuerman 1986). Many descendants of the Palus now live on the Colville Reservation. The Nez Perce, Yakama, Walla Walla, and Umatilla, and other Native American peoples also periodically visited to fish in the area. Traditional uses of the Hanford Site included fishing, hunting, and gathering roots and medicinal plants. The area was also used as a wintering ground. Descendants of these people retain traditional secular and religious ties to the region and many have knowledge of the ceremonies and life ways of their ancestral culture.

The Hanford Reach and the greater Hanford Site, geographic centers for regional Native American religious belief, are central to the practice of Indian religion of the region, and many believe the creator made the first people here (DOI 1994). Indian religious leaders began their teachings here, including Smoholla, a prophet of Priest Rapids who brought the Washani religion to the Wanapum and others during the late nineteenth century. Native plant and animal foods, some of which can be found on the Hanford Site, are used in the ceremonies performed by tribal members. Certain landforms, especially Rattlesnake Mountain, Gable Mountain, Gable Butte, and various sites along and including the Columbia River, remain sacred to them. Aesthetic and scenic resources are discussed in Section 4.8.10. The Gable Mountain Block Survey conducted by tribal members in 2000, recorded important attributes that contribute to the significance of Gable Mountain to Native Americans (Poston et al. 2001). Native American traditional cultural places within the Hanford Site include, but are not limited to, a wide variety of places and landscapes: archaeological sites, cemeteries, trails and pathways, campsites and villages, fisheries, hunting grounds, plant-gathering areas, holy lands, landmarks, important places in Indian history and culture, places of persistence and resistance, and landscapes of the heart (Bard 1997). Traditional cultural places of importance to Native Americans are determined through methods that are mutually agreed upon by DOE and the Native American community.

Native Americans have lived in and around the present-day Hanford Site for thousands of years (Relander 1956; Spier 1936; Sturtevant and Walker 1998). When Euro-Americans arrived in the 1800s, peoples presently referred to as the Wanapum inhabited villages and fishing camps. Neighboring groups known today as the Yakama, Umatilla, Cayuse, Walla Walla, Palus, Nez Perce, and Middle Columbia Salish frequented the area to trade, gather resources, and conduct other activities. Many descendants of these tribes are affiliated with the Wanapum, Yakama Nation, Confederated Tribes of the Umatilla Indian Reservation, Nez Perce Tribe, or the Confederated Tribes of the Colville Reservation, and they retain traditional, cultural, and religious ties to Hanford's places and resources. (See Section 6.14 for further information on the treaties associated with the Hanford Site). This record of Native American use and history is reflected in the archaeological sites and traditional cultural places that are located across the Hanford Site.

People have inhabited the Middle Columbia River region since the end of the glacial period. More than 8000 years of prehistoric human activity in this largely arid environment have left extensive archaeological deposits along the river shores (DOE-RL 2003a; Leonhardy and Rice 1970). Well-watered areas inland from the river also show evidence of concentrated human activity (Chatters 1982; DOE-RL 2003a; Daugherty 1952; Leonhardy and Rice 1970; Neitzel 2002a), and recent surveys have

indicated extensive, although dispersed, use of arid lowlands for hunting. Throughout most of the region, hydroelectric development, agricultural activities, and domestic and industrial construction have destroyed or covered the majority of these deposits. Amateur artifact collectors have had an immeasurable impact on what remains at numerous sites. However, by virtue of their inclusion in the Hanford Site from which the public is restricted, archaeological deposits found in the Hanford Reach of the Columbia River and on adjacent plateaus and mountains largely have not been destroyed.

Archaeological sites and isolated finds totaling 439 associated with the prehistoric period have been recorded on the site; of these, approximately 68 contain historic components as well. Prehistoric period sites common to the Hanford Site include remains of numerous pit house villages, various types of open campsites, spirit quest monuments (rock cairns), hunting camps, game drive complexes, and quarries in nearby mountains and rocky bluffs (Rice 1968a, b; Neitzel 2002a); hunting/kill sites in lowland stabilized dunes; and small temporary camps near perennial sources of water located away from the river (Rice 1968b).

Many recorded sites were found during four archaeological reconnaissance projects conducted between 1926 and 1968 (Krieger 1928; Rice 1968a,b). Much of this early archaeological survey and reconnaissance activity concentrated on islands and on a strip of land about 400 m (1300 ft) wide on either side of the river (Neitzel 2001). Reconnaissance of selected locations conducted through the mid-1980s, as well as systematic archaeological surveys conducted from the middle 1980s through 1996, added to the recorded site inventories, (DOE-RL 2003a; Chatters and Cadoret 1990; Chatters and Gard 1992; Chatters et al. 1990, 1991, 1992; Last et al. 1994; Andrefsky et al. 1996).

During his reconnaissance of the Hanford Site in 1968, Rice (1968b) inspected portions of Gable Mountain, Gable Butte, Snively Canyon, Rattlesnake Mountain, and Rattlesnake Springs. Rice also inspected additional portions of Gable Mountain and part of Gable Butte in the late 1980s (Neitzel 2001). Some reconnaissance of the Basalt Waste Isolation Project (BWIP) Reference Repository Location (Neitzel 2001), a proposed land exchange in T. 22 N., R. 27 E., Section 33 (Neitzel 2001), and three narrow transportation and utility corridors (Morgan 1981; Smith et al. 1977) was also conducted. Other large-scale project areas completed in recent years include the 100 Areas from 1991 through 1993 and 1995 (Chatters et al. 1992; Wright 1993); McGee Ranch (Gard and Poet 1992); the Laser Interferometer Gravitational Wave Observatory Project; the Environmental Restoration Disposal Facility; and the Washington State University 600 Area Block Survey (Andrefsky et al. 1996). To date, approximately 12 percent of the Hanford Site has been surveyed for archaeological resources.

#### **4.7.2 Historic Archaeological Resources**

Two of the early Euro-Americans who passed near the Hanford Site were Lewis and Clark, who traveled along the Columbia and Snake rivers during their 1803 to 1806 exploration of the Louisiana Territory. The first European explorer to cross the Hanford Site was David Thompson, who traveled along the Columbia River from Canada during his 1811 exploration of the Columbia River. Other visitors included fur trappers, military units, and miners who traveled through the Hanford Site on their way to lands up and down the Columbia River and across the Columbia Basin. It was not until the 1860s that merchants set up stores, a freight depot, and the White Bluffs Ferry on the Hanford Reach. Chinese

miners soon began to work the gravel bars for gold. Cattle ranches were established in the 1880s, and farmers soon followed. Agricultural development, irrigation districts, and roads soon dotted the landscape, particularly in the eastern portion of the central Hanford Site. Several small thriving towns, including Hanford, White Bluffs, Richland, and Ringold, grew up along the riverbanks in the early twentieth century. Community accessibility to outside markets grew with the 1913 arrival of the Chicago, Milwaukee, St. Paul, and Pacific Railroad branch line (Priest Rapids-Hanford Line) from Beverly, Washington. Ferries were established at Richland, Hanford, Wahluke, White Bluffs, and Richmond. The towns and nearly all other structures were razed in the years after the U.S. government acquired the land for the Hanford Engineer Works in 1943 (DOE-RL 2003a; Neitzel 2002a).

Since 1987, the Hanford Cultural Resources Laboratory (HCRL) has recorded 655 historic archaeological sites associated with the pre-Hanford (Euro-American) era, the Manhattan Project, and Cold War Era, including an assortment of farmsteads, corrals, dumps, and military sites. Of these, 56 sites contain prehistoric components as well. Archaeological resources from the pre-Hanford period are scattered over the entire Hanford Site and include numerous areas of gold mining features along the riverbanks of the Columbia and remains of homesteads, building foundations, agricultural equipment and fields, ranches, and irrigation features. Properties from this period include the Hanford Irrigation Ditch; former Hanford Townsite; Wahluke ferry landing; White Bluffs Townsite; Richmond ferry landing; Arrowsmith Townsite; White Bluffs road; and the Chicago, Milwaukee, St. Paul, and Pacific Railroad.

Areas of traditional cultural importance to pre-Hanford residents are also found on the Hanford Site. These areas include places and structures that are important to descendants of pre-1943 settlers in the former White Bluffs, Hanford, Allard, and Cold Creek areas.

### **4.7.3 Historic Built Environment**

A number of buildings associated with the pre-Hanford Site era have been documented. They include the Hanford Irrigation and Power Company pumping plant at Coyote Rapids, the high school and the electrical substation at the Hanford Townsite, First Bank of White Bluffs, Bruggemann's fruit warehouse, and the blacksmith cabin at the East White Bluffs ferry landing.

Historic built resources documented from the Manhattan Project and Cold War eras include buildings and structures found in the 100, 200, 300, 400, 600, 700, and former 1100 and 3000 Areas. The most important of these are the plutonium production and test reactors, chemical separation and plutonium finishing buildings, and fuel fabrication/manufacturing facilities. The first reactors, 100-B, 100-D, and 100-F, were constructed during the Manhattan Project. Plutonium for the first atomic explosion and the bomb that destroyed Nagasaki was produced at the Hanford Site. Additional reactors and processing facilities were constructed after World War II during the Cold War period. All reactor containment buildings still stand, although many ancillary structures have been removed, and the C, D, DR, F, and H reactors have been considerably modified.

Historic contexts were completed for the Manhattan Project and Cold War eras as part of a National Register Multiple Property Documentation Form prepared for the Hanford Site to assist with the evaluation of National Register of Historic Places (National Register) eligibility of buildings and structures

sitewide (Bard 1997). Additionally, historical narratives and individual building documentations have been compiled in the *History of the Plutonium Production Facilities at the Hanford Site Historic District, 1943-1990*, published in 2002 (DOE-RL 2002). At the site, 528 Manhattan Project and Cold War Era buildings/structures and complexes have been determined to be eligible for the National Register as contributing properties within the designated Hanford Site Manhattan Project and Cold War Era Historic District. Of that number, 190 were recommended for individual documentation (DOE-RL 1998).

#### 4.7.4 200 Areas

Much of the 200 East and West Areas has been disturbed by construction of facilities associated with the chemical separations process as part of the Manhattan Project and Cold War Era. Other facilities have been constructed as part of ongoing cleanup efforts for the Hanford Site. Comprehensive efforts were made in 1986 and 1989 to inventory the undisturbed portions of the 200 East and West Areas for cultural resources. The 1989 survey was “an intensive pedestrian survey of all undisturbed portions of the 200 East Area and a stratified random survey [of the undisturbed portions] of the 200 West Area” (Chatters and Cadoret 1990). No cultural resources are known to exist within currently active borrow areas (DOE 2001a).

The 1989 survey located two historic-archaeological sites (can and glass scatters), four isolated historic artifacts, one isolated cryptocrystalline flake, and an extensive linear feature (that is, the White Bluffs Road). These were the only materials older than 50 years discovered during the field survey. A prominent archaeological resource located in the 200 Areas is the extensive linear feature known as the White Bluffs Road, a portion of which passes diagonally southwest to northeast through the 200 West Area. This road, in its entirety, was determined eligible for listing in the National Register. Within the 200 West Area, two intact segments of the road are considered contributing elements: 1) the southwest segment from the perimeter fence to approximately 19<sup>th</sup> Street at Dayton Avenue, and 2) the extreme northeast segment above T Plant Complex to the perimeter fence. A 100-m (328-ft) easement has been created to protect these segments of the road from uncontrolled disturbance. The remaining portions of the road within the 200 West Area have been determined to be non-contributing. Such non-contributing segments of the White Bluffs Road are those that do not add to the historic significance of the road, but retain evidence of its contiguous bearing. Originally used as a Native American trail, it played a role in Euro-American immigration, development, agriculture, and Hanford Site operations. In 1996, an inventory was completed of the remainder of the undisturbed ground; an area totaling 2.2 km<sup>2</sup> (0.85 mi<sup>2</sup>). Although six isolated finds and two historic debris scatters were located, none were considered to be eligible for the National Register. A survey of the White Bluffs Road in 2000 recorded an additional 54 historic isolated finds and 2 prehistoric isolated finds, as well as six can dump features (Neitzel 2002a).

Although other areas of undisturbed land in the 200 East and 200 West Areas have been surveyed as part of cultural resource reviews of proposed projects, no new significant cultural resources have been located. Reviews include the 1989 permit application for the LLBGs (218-E-10, 218-E-12B, 218-W-3A, 218-W-3AE, 218-W-4B, 218-W-4C, 218-W-5, 218-W-6) (Hanford Cultural Resources Case [HCRC] # 89-200-008; see Table K.1). Previous borrowing and burying activities at the grounds had extensively

disturbed the majority of the LLBGs. However, portions of 218-E-12B, 218-W-5 and 218-W-6 were undisturbed. These areas were surveyed and reviewed by the HCRL in the summer of 1988 as part of HCRC# 88-200-038 (see Table K.1) and clearance for the project was granted. The ETF location was reviewed for the presence or absence of cultural resources in 1990 (HCRC# 89-200-023; see Table K.1). The WRAP Facility location was reviewed in 1993 (HCRC# 93-200-074; see Table K.2) and the CWC was reviewed in 1995 (HCRC# 95-200-104; see Table K.1). No significant resources were identified. Over the past 15 years, 50 cultural resource reviews were conducted on the LLBGs for grouting, geologic testing, subsidence repair and maintenance, removal of contaminated soils, retrieval of vented drums, culvert installation, drilling to install high-integrity containers, and trench construction.

Chemical separations facilities (processing plants and their ancillary and support services) were located in the 200 Areas. Irradiated fuel elements were dissolved and desired materials such as plutonium were separated out. Historic property inventory forms have been completed for 72 buildings and structures in the 200 Area. Of that number, 58 have been determined to be eligible for the National Register as contributing properties within the Historic District recommended for mitigation. Included are the 234-5Z Plutonium Finishing Plant, 236-Z Plutonium Reclamation Facility, 242-Z Water Treatment Facility, 231-Z Plutonium Metallurgical Laboratory, 225-B Encapsulation Building, 221-T Canyon (T Plant) Building, 202-A Purex Building, 222-S Redox Plant, 212-N Lag Storage Facility, 282-E Pumphouse and Reservoir Building, 283-E Water Filtration Plant, and 284-W Power House and Steam Plant. The 232-Z Waste Incinerator Facility and the 233-S Plutonium Concentration Building, determined eligible for the National Register, have been documented to Historic American Engineering Record (HAER) standards (DOE-RL 1998).

Completed in December 1944, T Plant (221-T) was the world's first large-scale plutonium (chemical) separation facility. T Plant, like the other chemical separation buildings at Hanford, is a massive, concrete, canyon-like structure measuring 800 feet long, 65 feet wide, and 80 feet high. Because of its role as the primary chemical separations plant at the Hanford Site from 1944 until the opening of the REDOX Plant in 1952, T Plant was found to be eligible for inclusion in the National Register as a contributing property within the Historic District and recommended for individual documentation (mitigation). Mitigation of T Plant has been completed and consisted of a HAER documentation of the facility and a walkthrough/assessment of the building contents. Industrial artifacts at T Plant and other historic facilities in the 200 Area were identified and tagged for future exhibit purposes.

DOE entered into the Programmatic Agreement for the Maintenance, Deactivation, Alteration, and Demolition of the Built Environment on the Hanford Site (DOE-RL 1996) with the Advisory Council on Historic Preservation and the Washington State Historic Preservation Office. One stipulation of the agreement requires DOE to undertake an assessment of the contents of the historic buildings and structures prior to any deactivation, decommissioning, or decontamination activities. The purpose of these assessments is to locate any artifacts that may have interpretive and or educational value as exhibits within local, state, or national museums.

## 4.8 Socioeconomic Activity

Activity on the Hanford Site plays a dominant role in the socioeconomic activity of the Tri-Cities and other parts of Benton and Franklin counties. The agricultural community also has a significant effect on the local economy. Any major changes in the Hanford mission could potentially affect the Tri-Cities and other areas of Benton and Franklin counties.

### 4.8.1 Local Economy

Three major sectors have been the principal driving forces of the economy in the Tri-Cities since the early 1970s: 1) DOE and its contractors operating the Hanford Site; 2) Energy Northwest (formerly the Washington Public Power Supply System) in its construction and operation of nuclear power plants; and 3) the agricultural community, including a substantial food-processing component. With the exception of a minor amount of agricultural commodities sold to local-area consumers, the goods and services produced by these sectors are exported outside the Tri-Cities. In addition to the direct employment and payrolls, these major sectors also support a sizable number of jobs in the local economy through their procurement of equipment, supplies, and business services.

In addition to these three major employment sectors, three other components can be readily identified as contributors to the economic base of the Tri-Cities: payrolls from the five major non-Hanford employers in the region, tourism, and pension benefits from former employees.

#### 4.8.1.1 Employment and Income

**DOE Hanford Site Employment.** During FY 2001, the DOE Office of River Protection (ORP) and its prime contractors CH2M Hill Hanford Group, Inc. and Bechtel National, Inc.; DOE-RL and its prime contractors Fluor Hanford, Inc. (and its principal subcontractors); PNNL; Bechtel Hanford, Inc.; and the Hanford Environmental Health Foundation employed an average of 10,700 employees. Fiscal year 2001 year-end employment at Hanford was 10,670, down slightly from 10,870 in FY 2000. In FY 1999, average employment was 10,290, compared with an average employment of 11,940 in 1996. The drop between FY 1996 and FY 1999 reflects employment declines and reorganization of the DOE contractors under the Project Hanford Management Contract (PHMC), which was created in 1996. Under the PHMC, almost 2200 employees of the former management and operations contractor were moved into six “enterprise companies” and were no longer counted as official Hanford employees. The number of employees at Hanford is down considerably from a peak of 19,200 in FY 1994, but still represents 12 percent of the 89,100 total jobs in the economy.

Based on employee residence records as of April 2002, 92 percent of the direct employees of Hanford live in Benton and Franklin counties. Approximately 73 percent of Hanford employees reside in Richland, Pasco, or Kennewick. More than 36 percent are Richland residents, 9 percent are Pasco residents, and 28 percent live in Kennewick. Residents of other areas of Benton and Franklin counties, including West Richland, Benton City, and Prosser, account for about 18 percent of total Hanford Site employment (Neitzel 2002a).

## 4.8 Socioeconomic Activity

Activity on the Hanford Site plays a dominant role in the socioeconomic activity of the Tri-Cities and other parts of Benton and Franklin counties. The agricultural community also has a significant effect on the local economy. Any major changes in the Hanford mission could potentially affect the Tri-Cities and other areas of Benton and Franklin counties.

### 4.8.1 Local Economy

Three major sectors have been the principal driving forces of the economy in the Tri-Cities since the early 1970s: 1) DOE and its contractors operating the Hanford Site; 2) Energy Northwest (formerly the Washington Public Power Supply System) in its construction and operation of nuclear power plants; and 3) the agricultural community, including a substantial food-processing component. With the exception of a minor amount of agricultural commodities sold to local-area consumers, the goods and services produced by these sectors are exported outside the Tri-Cities. In addition to the direct employment and payrolls, these major sectors also support a sizable number of jobs in the local economy through their procurement of equipment, supplies, and business services.

In addition to these three major employment sectors, three other components can be readily identified as contributors to the economic base of the Tri-Cities: payrolls from the five major non-Hanford employers in the region, tourism, and pension benefits from former employees.

#### 4.8.1.1 Employment and Income

**DOE Hanford Site Employment.** During FY 2001, the DOE Office of River Protection (ORP) and its prime contractors CH2M Hill Hanford Group, Inc. and Bechtel National, Inc.; DOE-RL and its prime contractors Fluor Hanford, Inc. (and its principal subcontractors); PNNL; Bechtel Hanford, Inc.; and the Hanford Environmental Health Foundation employed an average of 10,700 employees. Fiscal year 2001 year-end employment at Hanford was 10,670, down slightly from 10,870 in FY 2000. In FY 1999, average employment was 10,290, compared with an average employment of 11,940 in 1996. The drop between FY 1996 and FY 1999 reflects employment declines and reorganization of the DOE contractors under the Project Hanford Management Contract (PHMC), which was created in 1996. Under the PHMC, almost 2200 employees of the former management and operations contractor were moved into six “enterprise companies” and were no longer counted as official Hanford employees. The number of employees at Hanford is down considerably from a peak of 19,200 in FY 1994, but still represents 12 percent of the 89,100 total jobs in the economy.

Based on employee residence records as of April 2002, 92 percent of the direct employees of Hanford live in Benton and Franklin counties. Approximately 73 percent of Hanford employees reside in Richland, Pasco, or Kennewick. More than 36 percent are Richland residents, 9 percent are Pasco residents, and 28 percent live in Kennewick. Residents of other areas of Benton and Franklin counties, including West Richland, Benton City, and Prosser, account for about 18 percent of total Hanford Site employment (Neitzel 2002a).



**Energy Northwest.** Although activity related to commercial nuclear power plant construction ceased with the completion of the WNP-2 reactor in 1983 (now named Columbia Generating Station), Energy Northwest continues to be a major employer in the Tri-Cities area. Headquarters personnel based in Richland oversee the operation of the Columbia Generating Station. Decommissioning of mothballed nuclear power plants (WNP-1 and WNP-4), which never were completed, began in 1995. In FY 1999, Energy Northwest employed around 29 people at the two plants (one-third of the 90 people who were employed in 1994 as a result of decommissioning activities). As part of an effort to reduce electricity production costs, Energy Northwest headquarters decreased the size of its workforce from over 1900 in 1994 to 1016 at the end of 1999. As part of a refueling and maintenance project, as of April 2002 employment was 1208 personnel.

**Agriculture.** In 2000, agricultural production and services in the bi-county area generated about 10,260 wage and salary jobs, or about 12 percent of the area's total employment, as represented by the employees covered by unemployment insurance (LMEA 2001a). Seasonal farm workers are not included in that total but are estimated by the U.S. Department of Labor (DOL) for the agricultural areas in the state of Washington. In 2001, there was an average of 5148 seasonal farm workers per month in Benton, Franklin, and Walla Walla counties, ranging from 1153 workers during the winter pruning season to 11,329 workers at the peak of harvest. An estimated average of 4391 seasonal workers were classified as local (ranging from 1131 to 10,054); an average of 15 were classified as intrastate (ranging from 0 to 146), and an average of 748 were classified as interstate (ranging from 0 to 1612). The weighted seasonal wage for 2001 ranged from \$6.20/hr to \$7.58/hr, with an average wage of \$6.88/hr (DOL 2001).

According to the U.S. Department of Commerce's Regional Economic Information System (REIS), about 2640 people were classified as farm proprietors in 2000. Farm proprietors' income, according to this same source, was estimated to be \$53.2 million (DOC 2001).

The area farms and ranches generate a sizable number of jobs in supporting activities, such as agricultural services (for example, application of pesticides and fertilizers and irrigation system development) and wholesale trade (farm supply and equipment sales, and fruit packing). Although formally classified as a manufacturing activity, food processing is a natural extension of the farm sector. More than 20 food processors in Benton and Franklin counties produce such items as potato products, canned fruits and vegetables, wine, and animal feed.

**Other Major Employers.** In 2001, the five largest non-Hanford Site and non-government employers employed approximately 5035 people in Benton and Franklin counties. These companies include (1) Lamb Weston, which employed 1800; (2) Iowa Beef Processing Inc., which employed 1450; (3) Framatome ANP, Richland Inc. (formerly Siemens Power Corporation), which employed 750; (4) Boise Cascade Corporation Paper and Corrugated Container Divisions, which employed 685, and (5) Burlington Northern and Santa Fe Railway, which employed 350. Boise Cascade and Iowa Beef are located in western Walla Walla County, but most of their workforce resides in Benton and Franklin counties. Four of the largest agriculture growers and processors in the area: Broetje Orchards, J.R. Simplot Company, Twin City Foods, Inc., and AgriNorthwest, employed approximately 2000 people in 2001; however, a large portion of the workers were seasonal (TRIDEC 2002).

**Employment and Income Figures.** In 2001, nonagricultural employment rose 4 percent. There was an average of 78,500 nonagricultural jobs in the Tri-Cities in 2001, up approximately 3000 from year 2000. Gains in employment ranged from 100 workers in the manufacturing sector to, 700 in services, as every sector added workers except finance, insurance, and real estate, which stayed the same (LMEA 2001b).

In 2000, the total personal income for Benton County was \$3.7 billion and for Franklin County was \$932 million, compared with the Washington state total of \$184.5 billion. Per capita income in 2000 was \$25,624 for Benton County, \$18,813 for Franklin County, and \$31,230 for Washington State (DOC 2001). The preliminary estimate of median household income in 2001 for Benton County is \$48,893; Franklin County is estimated at \$40,976, and for Washington is estimated at \$48,835 (OFM 2001).

#### **4.8.1.2 Tourism**

A significant rise in the number of visitors to the Tri-Cities over the last several years has resulted in tourism playing an increasing role in helping to diversify and stabilize the area economy. The Tri-Cities Visitors and Convention Bureau reported that 97,770 people attended conventions and sporting events, spending an estimated \$32.3 million in the Mid-Columbia in 2001. The number of people attending convention and group events has more than doubled since 1995 and more than tripled since 1991.

The importance of tourism is evidenced by the amount of money spent on local goods and services. Overall tourism expenditures in the Tri-Cities were roughly \$220 million in 2000, up from \$204.7 million in 1999. Travel-generated employment in Benton and Franklin counties was about 4120 with an estimated \$56.4 million in payroll, up from an estimated 4090 employed and a \$44.7 million payroll in 1999. In addition, tourism generated \$3.4 million in local taxes and \$15.1 million in state taxes in 2000 (OTED 2002).

#### **4.8.1.3 Retirees**

Although Benton and Franklin counties have a relatively young population (approximately 53 percent under the age of 35), 19,523 people over the age of 65 resided in Benton and Franklin counties in 2002. The portion of the total population 65 years and older in Benton and Franklin counties accounts for 9.8 percent of the total population, which is below the 11.2 percent for the state of Washington (OFM 2003). This segment of the population supports the local economy on the basis of income received from government transfer payments and pensions, private pension benefits, and prior individual savings.

### **4.8.2 Environmental Justice**

Executive Order 12898, "Federal Actions to Address Environmental Justice in Minority Populations and Low-income Populations" (59 FR 7629), directs federal agencies in the Executive Branch to consider environmental justice so that their programs will not have "...disproportionately high and adverse human health or environmental effects..." on minority and low-income populations. Executive Order 12898 further directed federal agencies to consider effects to "populations with differential patterns of subsistence consumption of fish and wildlife." The Executive Branch agencies also were directed to develop

plans for complying with the Order. The Council on Environmental Quality (CEQ) provided additional guidance later for integrating environmental justice into the NEPA process in a December 1997 document, *Environmental Justice Guidance under the NEPA* (CEQ 1997).

Minority populations are defined as all nonwhite individuals, plus all individuals of Hispanic origin, as reported in the 2000 Census (Census 2001a). Low-income persons are defined as living in households that report an annual income less than the United States official poverty level, as reported by the Census Bureau. The poverty level varies by size and relationship of the members of the household. The year 2000 poverty level was \$17,761 for a family of four (Census 2001a). Nationally, in 1999, 29.9 percent of all persons were minorities, and 11.8 percent of all persons lived in households that had incomes less than the poverty level (which was \$17,029 for a family of four in that year) (Census 2000a, b). The year 2000 Census state and county area poverty estimates report that Washington had 11.6 percent of its population living in poverty in 1997, while Benton County and Franklin County had 10.3 percent and 19.2 percent, respectively (Census 2002).

The year 2000 Census data indicate that a total population of approximately 482,300 people resided within an 80-km (50-mi) radius of the Hanford Site. Based on the 2000 Census, the 80-km (50-mi) area surrounding the Hanford Site had a total minority population of about 178,500, about 37 percent of the total. The ethnic composition of the minority population is primarily White Hispanic (24 percent), self-designated “other” and multiple races (63 percent), and American Native (6 percent). Asians and Pacific Islanders (4 percent) and African American (3 percent) make up the remainder. The Hispanic population resides predominantly in Franklin, Yakima, Grant, and Adams counties. Native Americans within the 80-km (50-mi) area reside primarily on the Yakama Reservation, west of the Hanford Site, and upstream of the site near the town of Beverly, Washington.

Figure 4.25 shows the location of census block groups from the 2000 Census that had either a majority of residents who were members of a minority group (racial minority or Hispanic), or whose percentage of residents belonging to any minority group was at least 20 percentage points greater than the corresponding percentage of the state population (Census 2001b, c). Table 4.16 presents population estimates and percentages by race and Hispanic origin for Benton, Franklin, Grant, Adams, and Yakima counties, and the 80-km (50-mi) radius of the Hanford Site.

The 2000 low-income population was approximately 80,700 or 17 percent of the total population residing in the 80-km (50-mi) radius of the Hanford Site. The majority of these households were located to the southwest and north of the site (Yakima and Grant counties), and in the cities of Pasco and Kennewick.

Table 4.17 shows the estimated numbers and percentages of people living below the poverty level in the counties touched by the 80-km (50-mi) circle in Figure 4.26 for the year 2000. The low-income population of this larger area is dispersed throughout this region with the highest concentrations occurring in Franklin, Yakima, and Kittitas counties and the largest numbers in Benton, Yakima, and Grant counties

**Table 4.16.** Population Estimates and Percentages by Race and Hispanic Origin within Selected Counties in Washington State and the 80-km (50 mi) Radius of Hanford as Determined by the 2000 Census (Census 2003)

Subject	WA State	Percent	Benton/Franklin/Grant/ Adams/Yakima	Percent	Benton County	Franklin County	Grant County	Adams County	Yakima County	80 km (50 mi) Radius of Hanford <sup>(a)</sup>
Total Population	5,894,121	100	505,529	100	142,475	49,347	74,698	16,428	222,581	482,300
Single Race	5,680,602	96.4	489,206	96.8	138,646	47,302	72,451	15,977	214,830	482,280
White	4,821,823	81.8	367,283	72.7	122,879	30,553	57,174	10,672	146,005	347,047
Black or African American	190,267	3.2	5,494	1.1	1319	1230	742	46	2,157	5507
American Indian/Alaska Native	93,301	1.6	12,468	2.5	1165	362	863	112	9966	10,288
Asian	322,335	5.5	6809	1.3	3134	800	652	99	2124	6681
Native Hawaiian/Pacific Islander	23,953	0.4	482	0.1	163	57	53	6	203	479
Other Race	228,923	3.9	96,670	19.1	9986	14,300	12,967	5042	54,375	112,278
Two or More Races	213,519	3.6	16,323	3.2	3829	2045	2247	451	7751	20
Hispanic Origin (of any race) <sup>(b)</sup>	441,509	7.5	150,951	29.9	17,806	23,032	22,476	7732	79,905	149,588
(a) Includes a portion of Oregon.										
(b) Hispanic origin is not a racial category. It may be viewed as the ancestry, nationality group, lineage, or country of birth of the person or person's parents or ancestors before arrival in the United States. Persons of Hispanic origin may be of any race and are counted in the racial categories shown.										

**Table 4.17.** Number and Percentages of Persons Defined as Low-Income Living in Counties Near the Hanford Site, in 1999, as Determined by the 2000 Census (Census 2002)

	Number <sup>(a)</sup>		Percent Below Poverty Level
	All Income Levels	Below Poverty Level	
<b>Washington:</b>			
Adams County	16,217	2951	18.2
Benton County	141,232	14,517	10.3
Chelan County	65,564	8147	12.4
Columbia	4008	507	12.6
Franklin	48,307	9280	19.2
Grant County	73,591	12,809	17.4
Kittitas County	31,177	6,122	19.6
Klickitat County	18,983	3236	17.0
Walla Walla County	50,245	7567	15.1
Yakima County	218,966	43,070	19.7
<b>Oregon:</b>			
Morrow County	10,919	1617	14.8
Umatilla County	67,329	8524	12.7
Union County	23,795	3281	13.8
Total	770,333	121,628	15.8
(a) All individuals for whom poverty status is determined.			

The CEQ guidance recognizes that many minority and low-income populations derive part of their sustenance from subsistence hunting, fishing, and gathering activities (sometimes for species unlike those consumed by the majority population) or are dependent on water supplies or other resources that are atypical or used at different rates than other groups. These differential patterns of resource use are to be identified where practical and appropriate. There are Native Americans of various tribal affiliations that live in the greater Columbia Basin who rely on natural resources for subsistence.

There is some dependence on natural resources for dietary subsistence for the Nez Perce Tribe, the Confederated Tribes of the Umatilla Indian Reservation, and the Yakama Nation (Harris and Harper 1997). The treaties of 1855 maintain the rights of these tribes to fish and erect fish-curing structures in their usual and accustomed places, and to hunt, gather food, and graze stock on open and unclaimed portions of the lands ceded to the government. The Wanapum, a non-treaty tribe, historically lived on what is now the Hanford Site and continue to live adjacent to the Site. They fish on the Columbia River and gather food resources near the Hanford Site. The Confederated Tribes of the Colville Reservation, established by an Executive Order in 1872, traditionally fished and gathered food resources in the Hanford area. They are also recognized as having cultural and religious ties to the Hanford Site.

### **4.8.3 Demography**

Census 2000 report population totals for Benton and Franklin counties were 142,475 and 49,347, respectively (Census 2001b). Washington State did as a whole. The population of Benton County grew 26.6 percent up from 112,560 in 1990. The population of Franklin County grew 31.7 percent, up from 37,473 in 1990 (Census 2001b).

Within each county, census figures indicate the distribution of the Tri-Cities population by city as follows: Richland 38,708; Pasco 32,066; and Kennewick 54,693. The combined populations of Benton City, Prosser, and West Richland totaled 15,847 in 2000. The unincorporated population of Benton County was 33,227. In Franklin County, incorporated areas other than Pasco had a total population of 3595. The unincorporated population of Franklin County was 13,886 (Census 2001b).

The 2000 population figures for Benton and Franklin counties indicate that Asians represent a lower proportion, and individuals of Hispanic origin represent a higher proportion of the racial distribution than those in the state of Washington. Countywide, Benton and Franklin counties exhibit varying racial distributions.

In 2000, Benton and Franklin counties accounted for 3.3 percent of Washington's population. The population demographics of Benton and Franklin counties are quite similar to those found within Washington. The population in Benton and Franklin counties under the age of 35 is 53.1 percent, compared with 49.4 percent for Washington State. In general, the population of Benton and Franklin counties is somewhat younger than that of Washington. The 0- to 14-year-old age group accounts for 25.6 percent of the total bi-county population as compared with 21.3 percent for Washington. In 2000, the 65-year-old and older age group constituted 9.8 percent of the population of Benton and Franklin counties, compared with 11.2 percent for Washington (Census 2001b).

### **4.8.4 Housing**

In FY 2001, 2519 houses were sold in the Tri-Cities at an average price of \$134,570, compared with 2195 houses sold at an average price of \$128,928 in 2000 (TCAR 2001). In FY 2001, 869 single-family houses were built, up 14 percent from the 760 that were built in 2000, but down from a peak of 1117 in 1994 (WCRER 2001a).

As of April 1, 2001, there were estimated to be 73,410 housing units in Benton and Franklin counties, which is 26.4 percent more than the 58,541 in 1990 (OFM 2001). The number of apartments has increased from 8225 in 1990 to 10,238 in 2001. The vacancy rate of apartments in Benton and Franklin counties in September 2001 was 2.0 percent, and the average rent was \$576. These figures are down from the 4.3 percent vacancy rate and up from the \$530 average rent in 2000 (WCRER 2001b).

### **4.8.5 Traffic and Transportation**

The Tri-Cities serves as a regional transportation and distribution center with major air, land, and river connections. The Burlington Northern and Santa Fe Railway and the Union Pacific Railroad

companies provide direct rail service. Union Pacific operates the largest fleet of refrigerated rail cars in the United States and is essential to food processors that ship frozen food from this area. Amtrak provides passenger rail service with a station in Pasco.

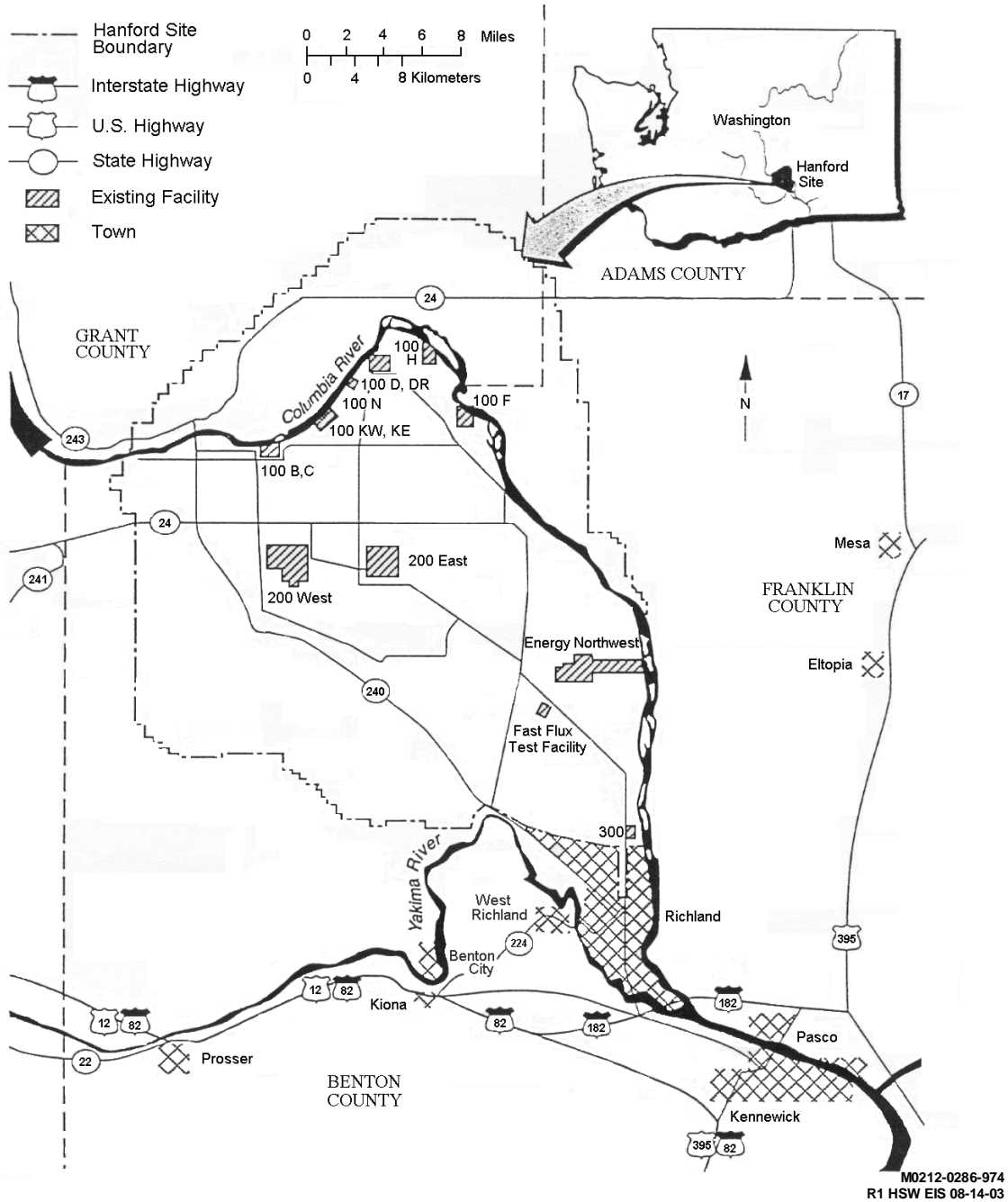
Docking facilities at the Ports of Benton, Kennewick, and Pasco are important aspects of the regional infrastructure. These facilities are located on the 525-km (326-mi) long commercial waterway that includes the Snake and Columbia Rivers and extends from the ports of Lewiston-Clarkston in Idaho to the deep-water ports of Portland, Oregon, and Vancouver, Washington. The average shipping time from the Tri-Cities to these deep-water ports by barge is 36 hours.

Daily air passenger and freight services connect the area with most major cities through the Tri-Cities Airport, located in Pasco. This modern commercial airport links the Tri-Cities to major hubs and provides access to destinations anywhere in the world. Delta Airlines, United Express, and Horizon Air offer 33 flights into and out of the Tri-Cities daily connecting to domestic and international flights through Salt Lake City, Seattle, Denver, Spokane, and Portland. A total of 206,188 passengers, used the Tri-Cities Airport in 2001, which was down slightly from 2000 when the airport set a record of 209,434 passengers and was the sixth year in a row of passenger increases. Projections indicate the terminal can serve almost 300,000 passengers annually. The Tri-Cities region has three general aviation airports that serve private aircraft. Air freight shippers that service the region include Airborne from the Richland airport, United Parcel Service from the Kennewick airport, and Federal Express from the Tri-Cities Airport in Pasco.

Mass transit in the area is provided by the Ben Franklin Transit system. The system covers more than 286 km<sup>2</sup> (110 mi<sup>2</sup>) and provides frequent service to most local communities. The Ben Franklin transit system consists of 54 buses, 31 Dial-a-Ride para-transit vehicles, and 75 Van Pool vans. Two local taxi companies provide radio-dispatched taxicab service 24 hours a day: A-1 Tri-Cities Cab and AMR Transportation. Intercity bus transportation is available.

The regional transportation network in the Hanford vicinity includes the areas in Benton and Franklin counties from which most of the commuter traffic associated with the site originates. Interstate (I) highways that serve the area are I-82 and I-182. I-82 is 8 km (5 mi) south-southwest of the Hanford Site. I-182, a 24-km (15-mi) long urban connector route, located 8 km (5 mi) south-southeast of the site, provides an east-west corridor linking I-82 to the Tri-Cities area. I-90, located north of the site, is the major link to Seattle and Spokane, and extends to the East Coast. I-82 serves as a primary link between Hanford and I-90, as well as I-84. I-84, located south of the Hanford Site in Oregon, is a major corridor leading to Portland, Oregon. SR 224, also south of the site, serves as a 16-km (10-mi) link between I-82 and SR 240. SR 24 enters the site from the west, continues eastward across the northernmost portion of the site, and intersects SR 17 approximately 24 km (15 mi) east of the site boundary. SR 17 is a north-south route that links I-90 to the Tri-Cities and joins U.S. Route 395, continuing south through the Tri-Cities. U.S. Route 395 north also provides direct access to I-90. SR 240 and 24 traverse the Hanford Site and are maintained by Washington State.

Waste may be shipped from sites throughout the United States. Potential transportation routes include Interstates I-70, I-90, I-80, I-15, I-5, I-84, I-82, I-182, I-64, I-81, I-76, and I-78, as well as numerous state and local roads (Figure 4.27). Potential offsite generators are listed in Appendix C and transportation distances for these generators are listed in Appendix H.



**Figure 4.27.** Transportation Routes in the Vicinity of the Hanford Site



A DOE-maintained road network within the Hanford Site consists of 607 km (377 mi) of asphalt-paved road, and provides access to the various work centers (Figure 4.28). Primary access roads on the Hanford Site are Routes 1, 2, 3, 4, 6, 10, and 11A. The 200 East Area is accessed primarily by Route 4 South from the east and from Route 4 North off Route 11A from the north and from Route 11A for vehicles entering the site at the Yakima Barricade. A new access road was opened in late 1994 to provide access directly to the 200 Areas from SR 240. Public access to the 200 Areas and interior locations of the Hanford Site has been restricted by guarded gates at the Wye Barricade (at the intersection of Routes 10 and 4), the Yakima Barricade (at the intersection of SR 240 and Route 11A), and Rattlesnake Barricade south of the 200 West Area. None of the previously listed roadways have experienced any substantial congestion except Route 4 (DOE 2001b). Onsite road usage is being assessed to determine whether roads could be closed to reduce the cost of infrastructure and maintenance.

Access to the Hanford Site is via three main routes, Hanford Route 4S from Stevens Drive or George Washington Way in the City of Richland, Route 10 from SR 240 near its intersection with SR 225, or via Route 11A from SR 240. Another route, through the Rattlesnake Barricade, is located 35 km (22 mi) northwest of Stevens Drive and is for passenger vehicle access only. The estimated total number of commuters to this area is 3100. Approximately 87 percent of the workers commuting to the 200 Areas are from the Tri-Cities, West Richland, Benton City, and Prosser (Perteet et al. 2001).

The portion of SR 240 most affected by 200 Area commuters is between U.S. 395 and Stevens Drive. Portions of this roadway currently operate below the minimum level of service established by the Regional Transportation Planning Organization. Peak annual average daily traffic (AADT) on the section from Columbia Center Boulevard to I-182 is 54,000 (Perteet et al. 2001).

I-182 has peak traffic counts of 35,000 AADT in the vicinity of SR 240. I-182 also has current deficiencies at the interchanges with Queensgate Drive and 20<sup>th</sup> Avenue. Van Giesen transports most of the commuters from West Richland and Benton City to SR 240. The intersection of SR 224 and SR 240 is the only section of SR 224 with current level of service (LOS) deficiencies. LOS is a qualitative measure of the roadway ability to accommodate vehicular traffic, ranging from free-flow conditions (LOS A) to extreme congestion (LOS F). LOS D is considered the lower end of acceptable LOS (Perteet et al. 2001).

Stevens Drive has peak traffic counts of 8300 AADT at Horn Rapids Road and 22,000 AADT just north of its intersection with SR 240. Currently this roadway experiences LOS deficiencies. George Washington Way is the principal north-south arterial through Richland. AADT at the entrance of the Hanford Site on George Washington Way is 1800. Counts north of McMurray are 18,000 AADT and on George Washington Way just north of I-182 are 43,000 AADT. George Washington Way has LOS deficiencies between I-182 and Swift Boulevard (Perteet et al. 2001).

Private vehicles account for 91 percent of the person trips to the Hanford Site. The remaining person trips are by forms of high-occupancy vehicles (mostly Ben-Franklin Vanpools). Of the 91 percent of private vehicles only 3 percent are by carpool with the remaining 88 percent being single occupancy vehicles. The Draft Regional Transportation Plan identifies 11,468 employees working at Hanford. Based on 88 percent of the trips carrying a single person to Hanford, 10,092 single occupancy trips are made daily or an AADT of 10,184 (Perteet et al. 2001).

The Hanford Site rail system originally consisted of approximately 210 km (130 mi) of track. It connected to the Union Pacific commercial track at the Richland Junction (at Columbia Center in Kennewick) and to a now-abandoned commercial right-of-way (Chicago, Milwaukee, St. Paul, and Pacific Railroad) near Vernita Bridge in the northwest section of the site. Prior to 1990, annual railcar movements numbered about 1400 sitewide, transporting materials including coal, fuel, hazardous process chemicals, and radioactive materials and equipment (DOE and Ecology 1996). In October 1998, 26 km (16 mi) of track from Columbia Center to Horn Rapids Road were transferred to the Port of Benton and are currently operated by the Tri-City & Olympia Railroad. The Port of Benton has been granted the right to operate portions of the railroad on the Hanford Site.

#### **4.8.6 Educational Services**

The majority of primary and secondary education in the Tri-Cities area is served by the Richland, Pasco, Kennewick, and Benton City School Districts. The total 2001 fall enrollment for all districts in Benton and Franklin counties was 40,590 students, an increase of 2.2 percent from the 2000 total of 39,702 students. The 2000 totals include 9622 from the Richland School District, up from 9464 in 2000; 9227 students from the Pasco School District, up from 8850 in 2000; 13,993 students from the Kennewick School District, up from 13,629 in 2000; and 1664 from the Kiona-Benton School District, down from 1673 in 2000 (OSPI 2002).

Several private elementary and secondary schools are located in the Tri-Cities, including Bethlehem Lutheran (K-8) and St. Josephs (K-8) in Kennewick, Christ the King (K-8) and Liberty Christian (K-12) in Richland, Faith Christian (K-12), Country Haven Academy (9-12), St. Patrick's (K-8), Tri-City Junior Academy (K-10), and Tri-Cities Prep Catholic High School in Pasco (9-12). Fall 2001 enrollment at these schools totaled 2350 students, an increase of 1.6 percent from the 2000 total of 2312 (OSPI 2002). Home schooling is prevalent in the Tri-Cities, with students totaling 544. Richland School District reports 205 students are home schooled within their jurisdiction, Pasco School District reports 113, and Kennewick School District has 226 students home schooled (Neitzel 2002b).

Post-secondary education in the Tri-Cities area is provided by Columbia Basin College (CBC), City University, and Washington State University, Tri-Cities branch campus (WSU-TC). The 2001 fall/winter enrollment was approximately 7750 at CBC, 100 at City University, and 1083 at WSU-TC. Many of the programs offered by these three institutions are geared toward the vocational and technical needs of the area. In the 2000-01 academic year, CBC offered 25 Associate in Applied Science (AAS) degree programs. City University offers two associate degree programs, four undergraduate, and three graduate programs, plus access to several more programs through Distance Learning. WSU-TC offers 14 undergraduate and 16 graduate programs, as well as access to graduate programs via satellite (Neitzel 2002a).

#### **4.8.7 Health Care and Human Services**

The Tri-Cities area has three major hospitals and five minor emergency centers, as well as a cancer treatment center. All three hospitals offer general medical services and each includes a 24-hour emergency room, basic surgical services, intensive care, and neonatal care.

The Tri-Cities offers a broad range of social services. State human service offices in the Tri-Cities include the Job Service Center within the Employment Security Department; food stamp offices; the Developmental Disabilities Division; financial and medical assistance; the Child Protective Service; emergency medical service; a senior companion program; and vocational rehabilitation.

The Tri-Cities is also served by a large number of private agencies and voluntary human service organizations. United Way incorporates 21 participating agencies offering 38 programs (Batchelor 2001 [see Volume II of this EIS, Appendix O]). These member agencies had a cumulative budget total of \$27 million in 2000. In addition, 572 organizations received funds as part of the United Way Benton-Franklin County donor designation program.

#### **4.8.8 Police and Fire Protection**

The Benton and Franklin County sheriff departments, local municipal police departments (Pasco, Kennewick, Richland, West Richland), and the Washington State Patrol Division in Kennewick provide local police protection.

Fire protection in the Tri-Cities area is provided by fire departments in Kennewick, Richland, and Pasco, a volunteer fire department in West Richland, and three rural fire departments in Benton County.

The Hanford Site Fire Department has fire stations onsite, and the Benton County Sheriff Department provides onsite law enforcement. Site security is provided onsite by the Hanford Patrol.

#### **4.8.9 Utilities**

The principal sources of water in the Tri-Cities and the Hanford Site are the Columbia River and groundwater. The water systems of Richland, Pasco, and Kennewick drew a large portion of the 51.5 billion L (13.6 billion gal) used in 2000 from the Columbia River. Each city operates its own supply and treatment system. The Richland water supply system derives about 82 percent of its water directly from the Columbia River, while the remainder is split between a well field in North Richland (that is recharged from the river) and groundwater wells. The city of Richland's total usage in 2001 was 25.2 billion L (6.7 billion gal). The Pasco system also draws from the Columbia River for its water needs. In 2001, Pasco consumed 11.8 billion L (3.1 billion gal). The Kennewick system uses two wells and the Columbia River for its supply. These wells serve as the sole source of water between November and March and can provide approximately 40 percent of the total maximum supply of 30 billion L (8 billion gal). Total 2001 usage in Kennewick was 13.2 billion L (3.5 billion gal) (Neitzel 2002a).

The Benton County Public Utility District, Benton Rural Electric Association, Franklin County Public Utility District, and City of Richland Energy Services Department provide the Tri-Cities with electricity. Almost all of the power these utilities provide in the local area is purchased from the Bonneville Power Administration (BPA) that also provides power to the Hanford Site. Natural gas, provided by the Cascade Natural Gas Corporation, serves approximately 11,000 customers in the Tri-Cities, as well as the 300 Area of the Hanford Site.

#### **4.8.10 Aesthetic and Scenic Resources**

Broad basins and plateaus interspersed with ridges characterize the Hanford Site landscape. The wide vistas composing much of the area are interrupted by numerous large industrial facilities (for example, reactors and processing facilities). However, DOE and its predecessors have disturbed only about 6 percent of the site. The remainder lies undeveloped and includes natural areas and abandoned agricultural lands that remain undisturbed because of restricted public access. The Hanford Reach National Monument was established in part because of these aesthetic and scenic resources.

The Columbia River flows through the northern portion of the Hanford Site before turning south and forming the eastern site boundary. The White Bluffs, steep whitish-brown cliffs adjacent to the Columbia River, comprise a striking natural feature of the landscape. Rattlesnake Mountain, rising to 1092 m (3581 ft) above mean sea level forms the southeastern boundary of the Hanford Site. Gable Mountain and Gable Butte are the highest landforms within the Hanford Site. Large rolling hills are located to the west and north.

SR 240 provides public access through the southwestern portion of the Hanford Site. Views along this highway include the open lands of the Fitzner/Eberhardt Arid Lands Ecology Reserve (ALE) in the foreground to the west, with the prominent peak of Rattlesnake Mountain and the extended ridgelines of the Rattlesnake Hills in the background. To the east, the views include relatively flat terrain with the structures of the 200 East and 200 West Areas visible in the central area with Gable Butte and Gable Mountain in the background. From the highway, the Saddle Mountains can be seen in the distance to the north and steam plumes from the Energy Northwest reactor cooling towers are often visible in the distance to the east. The views along SR 240 are expansive due to the flat terrain and the predominantly short, treeless, vegetation cover.

Hanford Site facilities can also be seen from elevated locations, such as Gable Mountain, Gable Butte, Rattlesnake Mountain, and other parts of the Rattlesnake Hills along the western perimeter. Facilities are visible from the Columbia River as well. Because of the vast expanse, terrain, and distances involved, only portions of the site are visible from any one point.

The acquisition of spiritual guidance and assistance through personal vision quests is deeply rooted in the religious practices of the indigenous people of the Columbia Basin. High spots were selected because they afforded extensive views of the natural landscape and seclusion for quiet meditation. These practices, and the areas where they took place, are critical in maintaining the continuing cultural identity of the Native American community, and, as such, are eligible for inclusion in the National Register. The high points of the Hanford Site, including Gable Mountain, Rattlesnake Mountain, and Wahluke Slope, are representative of locations where vision quests were conducted. The physical landscape visible from each location is a means to determine areas and resources of concern.

### **4.9 Noise**

Noise is technically defined as sound waves that are unwanted and perceived as a nuisance by humans. Sound waves are characterized by frequency, measured in Hertz (Hz), and sound pressure

#### **4.8.10 Aesthetic and Scenic Resources**

Broad basins and plateaus interspersed with ridges characterize the Hanford Site landscape. The wide vistas composing much of the area are interrupted by numerous large industrial facilities (for example, reactors and processing facilities). However, DOE and its predecessors have disturbed only about 6 percent of the site. The remainder lies undeveloped and includes natural areas and abandoned agricultural lands that remain undisturbed because of restricted public access. The Hanford Reach National Monument was established in part because of these aesthetic and scenic resources.

The Columbia River flows through the northern portion of the Hanford Site before turning south and forming the eastern site boundary. The White Bluffs, steep whitish-brown cliffs adjacent to the Columbia River, comprise a striking natural feature of the landscape. Rattlesnake Mountain, rising to 1092 m (3581 ft) above mean sea level forms the southeastern boundary of the Hanford Site. Gable Mountain and Gable Butte are the highest landforms within the Hanford Site. Large rolling hills are located to the west and north.

SR 240 provides public access through the southwestern portion of the Hanford Site. Views along this highway include the open lands of the Fitzner/Eberhardt Arid Lands Ecology Reserve (ALE) in the foreground to the west, with the prominent peak of Rattlesnake Mountain and the extended ridgelines of the Rattlesnake Hills in the background. To the east, the views include relatively flat terrain with the structures of the 200 East and 200 West Areas visible in the central area with Gable Butte and Gable Mountain in the background. From the highway, the Saddle Mountains can be seen in the distance to the north and steam plumes from the Energy Northwest reactor cooling towers are often visible in the distance to the east. The views along SR 240 are expansive due to the flat terrain and the predominantly short, treeless, vegetation cover.

Hanford Site facilities can also be seen from elevated locations, such as Gable Mountain, Gable Butte, Rattlesnake Mountain, and other parts of the Rattlesnake Hills along the western perimeter. Facilities are visible from the Columbia River as well. Because of the vast expanse, terrain, and distances involved, only portions of the site are visible from any one point.

The acquisition of spiritual guidance and assistance through personal vision quests is deeply rooted in the religious practices of the indigenous people of the Columbia Basin. High spots were selected because they afforded extensive views of the natural landscape and seclusion for quiet meditation. These practices, and the areas where they took place, are critical in maintaining the continuing cultural identity of the Native American community, and, as such, are eligible for inclusion in the National Register. The high points of the Hanford Site, including Gable Mountain, Rattlesnake Mountain, and Wahluke Slope, are representative of locations where vision quests were conducted. The physical landscape visible from each location is a means to determine areas and resources of concern.

### **4.9 Noise**

Noise is technically defined as sound waves that are unwanted and perceived as a nuisance by humans. Sound waves are characterized by frequency, measured in Hertz (Hz), and sound pressure

expressed as decibels (dB). Most humans have a perceptible hearing range of 31 to 20,000 Hz. A decibel is a standard unit of sound pressure. The threshold of audibility for most humans ranges from about 60 dB at a frequency of 31 Hz to less than about 1 dB between 900 and 8000 Hz. (For regulatory purposes, noise levels for perceptible frequencies are weighted to provide an A-weighted sound level [dBA] that correlates highly with individual community response to noise.) Sound pressure levels outside the range of human hearing are not considered noise in a regulatory sense, even though wildlife may be able to hear at these frequencies.

Noise levels are often reported as the equivalent sound level ( $L_{eq}$ ). The  $L_{eq}$  is expressed in dBA over a specified period of time, usually 1 or 24 hour(s). The  $L_{eq}$  is the equivalent steady sound level that, if continuous during a specified time period, would contain the same total energy as the actual time-varying sound over the monitored or modeled time period.

Environmental noise measurements were made on the Hanford Site in 1981 during site characterization for the Skagit/Hanford Nuclear Power Plant Site (NRC 1982). Measurements were also made at five locations during 1987 when the Hanford Site was considered for a geologic waste repository (BWIP) for spent commercial nuclear fuel and other high-level nuclear waste. Additionally, noise levels as a result of field activities, such as well drilling and sampling, were measured. Baseline offsite noise measurements attributable to automobile traffic were also determined.

During site characterization for the Skagit/Hanford Nuclear Power Plant (NRC 1982), 15 sites were monitored and noise levels were found to range from 30 to 60.5 dBA ( $L_{eq}$ ). The values for isolated areas ranged from 30 to 38.8 dBA. Measurements taken around the sites where Energy Northwest was constructing nuclear power plants (WNP-1, WNP-2, and WNP-4) ranged from 50.6 to 64 dBA. Measurements taken along the Columbia River near the intake structures for WNP-2 were 47.7 and 52.1 dBA, compared with more remote river noise levels of 45.9 dBA (measured about 4.8-km [3 mi] upstream of the intake structures). Community noise levels in north Richland (Horn Rapids Road and SR 240) were 60.5 dBA.

Background noise levels were determined at five locations within the Hanford Site for studies supporting the BWIP. Noise levels are expressed as  $L_{eqs}$  for 24 hr ( $L_{eq-24}$ ). On the dates tested, the average noise level for the five sites was 38.9 dBA. Wind was identified as the primary contributor to background noise levels, with winds exceeding 19 km/hr (12 mi/hr) significantly affecting noise levels. Background noise levels in undeveloped areas at Hanford can best be described as a mean  $L_{eq-24}$  of 24 to 36 dBA. Periods of high wind that normally occur in the spring would elevate background noise levels.

Baseline noise levels as a result of automobile traffic were determined for two locations: SR 24, leading from the Hanford Site west to Yakima, and SR 240, south of the site and west of Richland where the route handles maximum traffic volume (DOE 1991). Traffic volumes were predicted based on an operational workforce and a construction workforce. Peak (rush hour) and off-peak hours were modeled. Noise levels were expressed in  $L_{eq}$  for 1-hr periods in dBA at a receptor located 15 m (49 ft) from the road edge. Baseline noise levels during the construction phase were 62 dBA for SR 24 and 70.2 dBA

for SR 240. Levels based on the operational phase ranged from 62 to 65.7 dBA for SR 24 and 70.2 to 74.1 dBA for SR 240. Adverse community responses would not be expected at increases of 5 dBA over background noise levels.

In the interest of protecting Hanford workers and complying with Occupational Safety and Health Administration (OSHA) standards for noise in the workplace, that Hanford Environmental Health Foundation (HEHF) has monitored noise levels resulting from several routine operations performed at Hanford. Occupational sources of noise propagated in the field include well sampling, well drilling, water wagon operation, trucks, compressors, and generators. Noise levels from these activities ranged from 74.8 to 125 dBA (Neitzel 2002a) and have the potential for disturbing sensitive wildlife.

## **4.10 Occupational Safety**

Total occupational work hours at the Hanford Site for the 5-year period, 1997-2001, were 106,836,082 hours, or about 56,230 worker-years (DOE 2002). The DOE records occupational injuries and illnesses in four categories pertinent to NEPA analysis. Total recordable cases (TRCs) are work-related deaths, illnesses, or injuries resulting in loss of consciousness, restriction of work or motion, transfer to another job, or required medical treatment beyond first aid. Lost workday cases (LWCs) represent the number of cases recorded resulting in days away from work or days of restricted work activity, or both, for affected employees. Lost workdays (LWDs) are the total number of workdays (consecutive or not), after the day of injury or onset of illness, during which employees were away from work or limited to restricted work activity because of an occupational injury or illness. Fatalities are the number of occupationally related deaths. Information on occupational safety used in this section is updated quarterly and is available at URL: <http://tis.eh.doe.gov/cairs>.

Occupational injury and illness incidence rates for the Hanford Site Office of River Protection showed a steady decrease from 1997 through 2000 (Figure 4.29). Rates ranged from 3.0 cases per 200,000 worker hours (100 worker years) in 1997 to 1.7 cases in 2001. Occupational injury and illness incidence rates for Richland Operations declined from 1997 to 2000, increasing slightly during 2001. In 1997 there were 3.1 cases per 200,000 worker hours. Rates decreased to 2.0 cases in 2000 and increased slightly in 2001 to 2.1 cases per 200,000 worker hours. Occupational injury and illness incidence rates for the DOE complex also demonstrate annual decreases, ranging from 3.5 cases per 200,000 worker hours during 1997 to 2.3 cases in 2001 (DOE 2002).

Over the 5-year period from 1997 to 2001, rates on the Hanford Site averaged 2.4 cases per 200,000 worker hours, whereas the incidence rate for the entire DOE complex averaged slightly higher, at 2.8 cases per 200,000 worker hours (DOE 2002). The Hanford Site and DOE-wide average TRC rates were well below the Bureau of Labor Statistics (BLS) rates for U.S. private industry of 6.7 cases per 200,000 worker hours during the same period (BLS 2002).

for SR 240. Levels based on the operational phase ranged from 62 to 65.7 dBA for SR 24 and 70.2 to 74.1 dBA for SR 240. Adverse community responses would not be expected at increases of 5 dBA over background noise levels.

In the interest of protecting Hanford workers and complying with Occupational Safety and Health Administration (OSHA) standards for noise in the workplace, that Hanford Environmental Health Foundation (HEHF) has monitored noise levels resulting from several routine operations performed at Hanford. Occupational sources of noise propagated in the field include well sampling, well drilling, water wagon operation, trucks, compressors, and generators. Noise levels from these activities ranged from 74.8 to 125 dBA (Neitzel 2002a) and have the potential for disturbing sensitive wildlife.

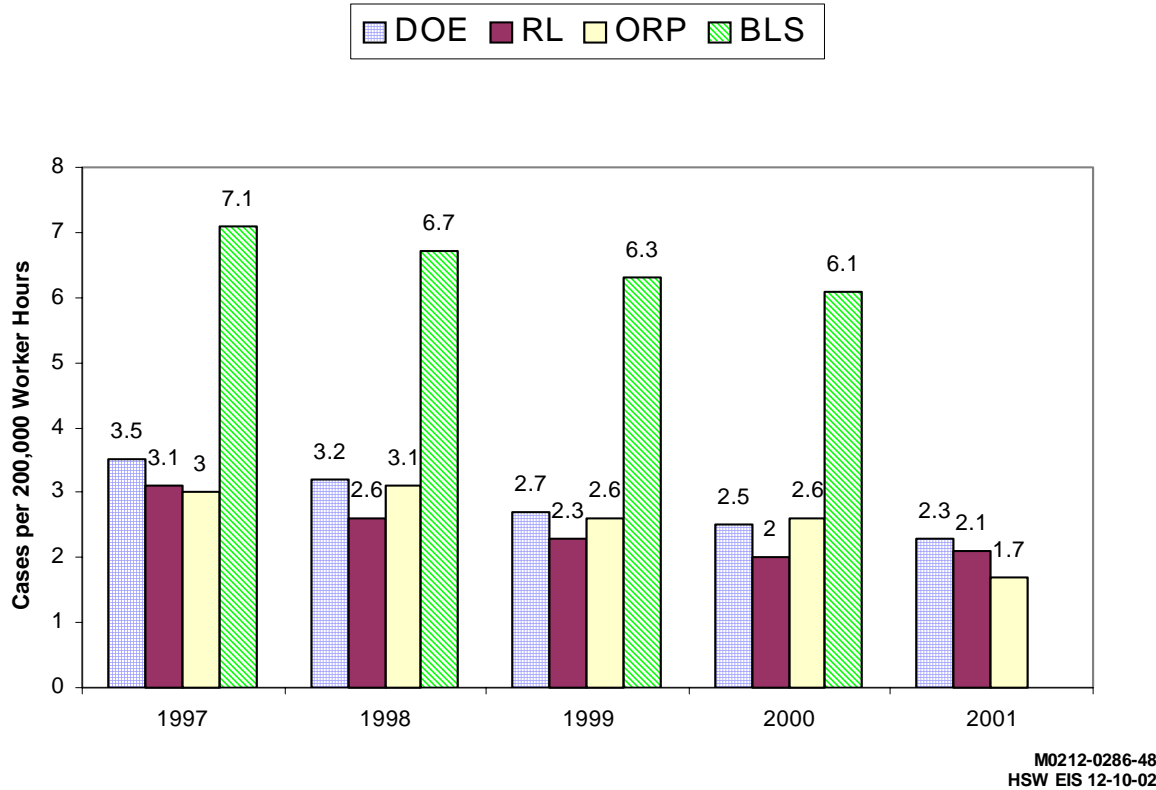
## **4.10 Occupational Safety**

Total occupational work hours at the Hanford Site for the 5-year period, 1997-2001, were 106,836,082 hours, or about 56,230 worker-years (DOE 2002). The DOE records occupational injuries and illnesses in four categories pertinent to NEPA analysis. Total recordable cases (TRCs) are work-related deaths, illnesses, or injuries resulting in loss of consciousness, restriction of work or motion, transfer to another job, or required medical treatment beyond first aid. Lost workday cases (LWCs) represent the number of cases recorded resulting in days away from work or days of restricted work activity, or both, for affected employees. Lost workdays (LWDs) are the total number of workdays (consecutive or not), after the day of injury or onset of illness, during which employees were away from work or limited to restricted work activity because of an occupational injury or illness. Fatalities are the number of occupationally related deaths. Information on occupational safety used in this section is updated quarterly and is available at URL: <http://tis.eh.doe.gov/cairs>.

Occupational injury and illness incidence rates for the Hanford Site Office of River Protection showed a steady decrease from 1997 through 2000 (Figure 4.29). Rates ranged from 3.0 cases per 200,000 worker hours (100 worker years) in 1997 to 1.7 cases in 2001. Occupational injury and illness incidence rates for Richland Operations declined from 1997 to 2000, increasing slightly during 2001. In 1997 there were 3.1 cases per 200,000 worker hours. Rates decreased to 2.0 cases in 2000 and increased slightly in 2001 to 2.1 cases per 200,000 worker hours. Occupational injury and illness incidence rates for the DOE complex also demonstrate annual decreases, ranging from 3.5 cases per 200,000 worker hours during 1997 to 2.3 cases in 2001 (DOE 2002).

Over the 5-year period from 1997 to 2001, rates on the Hanford Site averaged 2.4 cases per 200,000 worker hours, whereas the incidence rate for the entire DOE complex averaged slightly higher, at 2.8 cases per 200,000 worker hours (DOE 2002). The Hanford Site and DOE-wide average TRC rates were well below the Bureau of Labor Statistics (BLS) rates for U.S. private industry of 6.7 cases per 200,000 worker hours during the same period (BLS 2002).



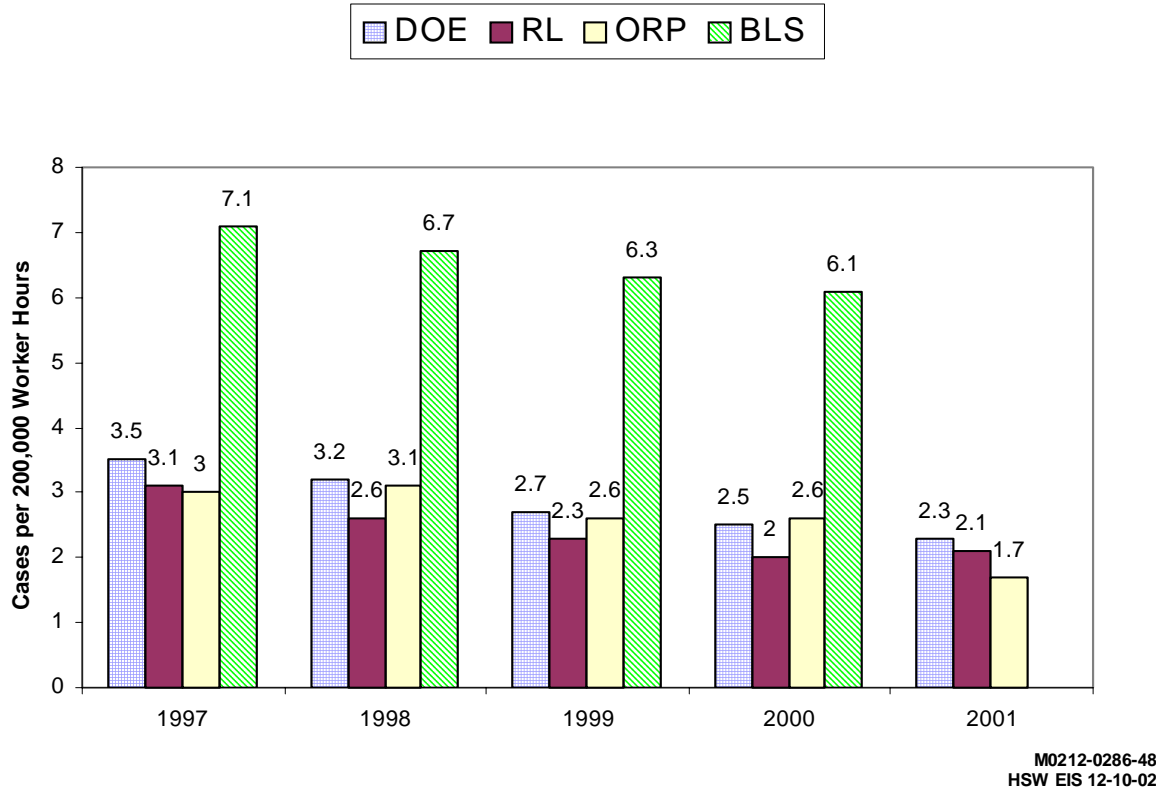


**Figure 4.29.** Occupational Injury and Illness Total Recordable Case Rates at the Hanford Site Compared with the DOE Complex and Private Industry (DOE 2002)

Table 4.18 shows occupational injury, illness, and fatality incidence rates reported for the private sector by the BLS (Department of Labor), and throughout the DOE complex, including DOE’s Richland Operations and Office of River Protection. During the 5-year period from 1997 to 2001, Hanford Site TRC and LWC rates were somewhat lower than those for DOE, whereas the private sector was consistently higher. Average LWD rates for Richland Operations for the 1997 to 2001 period were higher than Hanford’s Office of River Protection and the entire DOE complex. There were no fatalities at the Hanford Site during the 1997 to 2001 period (DOE 2002).

#### 4.11 Occupational Radiation Exposure at the Hanford Site

DOE’s Office of Safety and Health reports occupational radiation exposure data for all monitored DOE employees, contractors, subcontractors, and members of the public associated with DOE facilities. The total number monitored for the 5-yr period, 1997-2001, at the Hanford Site was 53,888 individuals. Waste processing and management facility employees monitored for the same period was 7404, or approximately 14 percent of the site workforce (DOE 2003).



**Figure 4.29.** Occupational Injury and Illness Total Recordable Case Rates at the Hanford Site Compared with the DOE Complex and Private Industry (DOE 2002)

Table 4.18 shows occupational injury, illness, and fatality incidence rates reported for the private sector by the BLS (Department of Labor), and throughout the DOE complex, including DOE’s Richland Operations and Office of River Protection. During the 5-year period from 1997 to 2001, Hanford Site TRC and LWC rates were somewhat lower than those for DOE, whereas the private sector was consistently higher. Average LWD rates for Richland Operations for the 1997 to 2001 period were higher than Hanford’s Office of River Protection and the entire DOE complex. There were no fatalities at the Hanford Site during the 1997 to 2001 period (DOE 2002).

#### 4.11 Occupational Radiation Exposure at the Hanford Site

DOE’s Office of Safety and Health reports occupational radiation exposure data for all monitored DOE employees, contractors, subcontractors, and members of the public associated with DOE facilities. The total number monitored for the 5-yr period, 1997-2001, at the Hanford Site was 53,888 individuals. Waste processing and management facility employees monitored for the same period was 7404, or approximately 14 percent of the site workforce (DOE 2003).

**Table 4.18.** Occupational Injury, Illness, and Fatality Incidence Rates for U.S. Department of Energy Facilities and Private Industry (DOE 2002)<sup>(a)</sup>

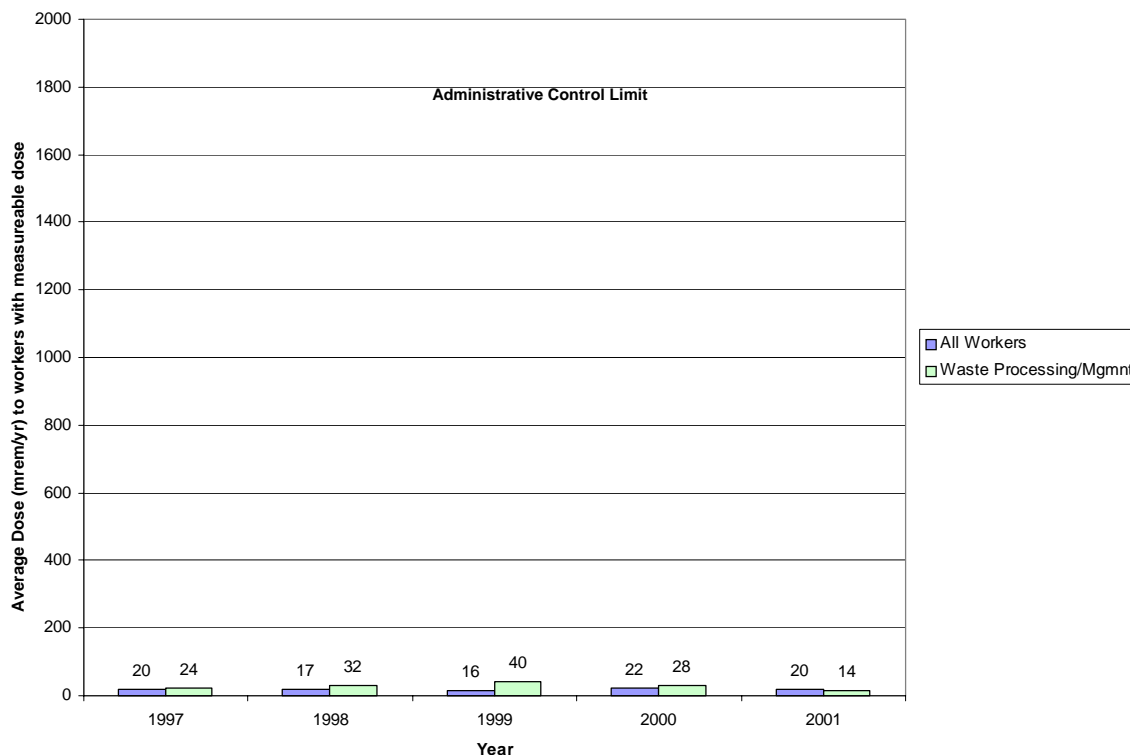
	Total Recordable Cases					Lost Work Cases					Lost Work Days					Fatalities
	1997	1998	1999	2000	2001	1997	1998	1999	2000	2001	1997	1998	1999	2000	2001	Average
Bureau of Labor Statistics	7.1	6.7	6.1	6.3	NA	3.3	3.1	3.0	3.0	NA	NA	NA	NA	NA	NA	
1997-2000 Average	6.6					3.1										0.0046
U.S. Department of Energy	3.5	3.2	2.7	2.5	2.3	1.7	1.5	1.2	1.1	1.0	52.3	42.6	44.9	33.8	23.0	
1997-2001 Average	2.8					1.3					39.3					0.0012
DOE Office of River Protection, Hanford Site	3.0	3.1	2.6	2.6	1.7	1.0	1.4	1.1	1.1	0.4	34.0	32.8	66.9	51.5	9.5	
1997-2001 Average	2.6					1.0					38.9					0
DOE Richland Operations Office, Hanford Site	3.1	2.6	2.3	2.0	2.1	1.3	1.1	1.0	0.8	0.7	47.9	56.8	50.4	27.8	26.0	
1997-2001 Average	2.4					1.0					41.8					0

(a) Per 200,000 worker hours (100 worker-years).

DOE has established dose limits in order to control radiation exposures. The primary DOE dose limit is 5000 mrem/yr (50 mSv/yr) to the whole body, expressed as the total effective dose equivalent (TEDE), which is the sum of dose due to radiation sources internal and external to the body (10 CFR 835).

A maximum DOE Administrative Control Level (ACL) of 2000 mrem/yr (20 mSv/yr) per person is recommended for all DOE activities. DOE organizations are encouraged to establish site and facility-specific ACLs below this 2000-mrem/yr (20-mSv/yr) value. An ACL of 500 mrem/yr (5 mSv/yr) has been established for the vast majority of Hanford workers. Higher ACLs than 500 mrem/yr (5 mSv/yr) have been necessary for only a very small number of Hanford workers. There were no individual worker doses in excess of the 2000-mrem/yr (20-mSv/yr) ACL or the 5000-mrem/yr (50-mSv/yr) TEDE regulatory limit doses at the Hanford Site during the period 1997-2001 (DOE 2003).

Nineteen percent of the total monitored Hanford Site employees and 27 percent of the waste processing and management facility employees had measurable dose during the 1997-2001 period. Figure 4.30 illustrates the average Hanford Site occupational dose (mrem/yr). The average occupational dose for all monitored waste processing and management facility employees decreased from 40 to 14 mrem/yr (400 to 140  $\mu$ Sv/yr) for the period 1999 to 2001, a decline of 65 percent. The average dose for all monitored Hanford workers for the same time period generally increased (from 16 mrem/yr [160  $\mu$ Sv/yr] in 1999 to 20 mrem/yr [200  $\mu$ Sv/yr] in 2001) (DOE 2003).



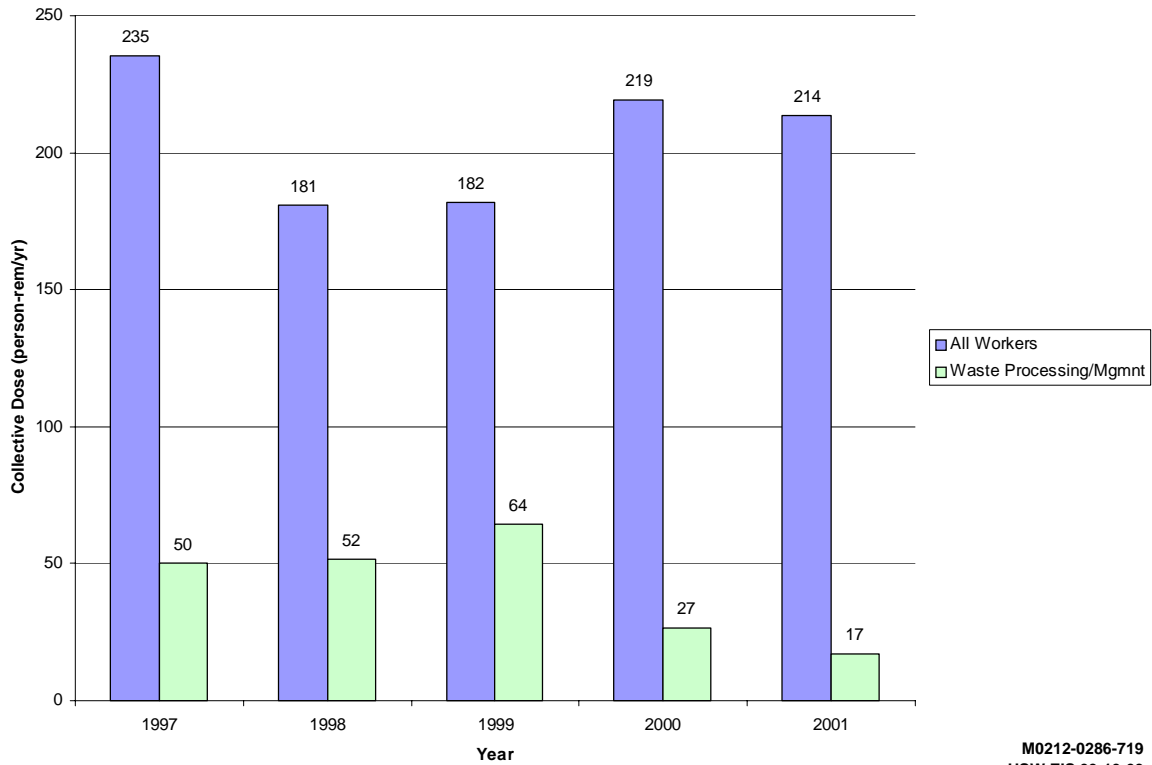
M0212-0286-718  
R1-HSW EIS 03-26-03

**Figure 4.30.** Average Occupational Dose (mrem/yr) to Hanford Site Individuals with Measurable Dose, 1997-2001 (DOE 2003)

Collective dose is the sum of the dose received by all individuals with measurable dose and is measured in units of person-rem. (For example, a dose of 1 rem to 10 people would result in a collective dose of 10 person-rem.) Figure 4.31 shows the collective operational dose (person-rem/yr) at Hanford for the years 1997-2001.

The collective dose at the Hanford Site has decreased for the waste processing and management facility employees from 64 to 17 person-rem/yr for the period 1999 to 2001, a 73 percent decline. The collective dose for all workers for the same time period increased.

Table 4.19 shows the radiation exposure data for the Hanford Site (DOE 2003). For the period 1997-2001, the total number of individuals monitored has generally decreased, while the number of individuals with measurable dose has increased. The 5-year average occupational dose for workers with measurable dose was similar for all Hanford workers (103 mrem/yr [1 mSv/yr]) and waste management facility workers (107 mrem/yr [1.1 mSv/yr]), well below the typical Hanford ACL of 500 mrem/yr (5 mSv/yr).



M0212-0286-719  
HSW EIS 03-10-03

Figure 4.31. Collective Operational Dose (person-rem/yr) at the Hanford Site, 1997-2001 (DOE 2003)

Table 4.19. Radiation Exposure Data for the Hanford Site, 1997-2001 (DOE 2003)

Year	Total Number Monitored	Number with Meas. Dose	Percent with Dose >0	Total Collective Dose (TEDE)		Average Dose to Workers (mrem)	
				(Person-rem/yr)	(Person-mrem/yr)	All Monitored	All with Dose >0
<b>Hanford Site</b>							
2001	10,485	2218	21%	214	213,628	20	96
2000	10,048	1923	19%	219	219,032	22	114
1999	11,310	2013	18%	182	182,000	16	90
1998	10,441	1772	17%	181	180,927	17	102
1997	11,604	2058	18%	235	235,355	20	114
<b>Cumulative Totals</b>							
1997-2001	53,888	9984	19%	1031	1,030,942	19	103
<b>Waste Processing/Management Facility</b>							
2001	1216	294	24%	17	17,277	14	59
2000	938	234	25%	27	26,722	28	114
1999	1598	479	30%	64	64,258	40	134
1998	1609	419	26%	52	51,728	32	123
1997	2043	538	26%	50	50,033	24	93
<b>Cumulative Totals</b>							
1997-2001	7404	1964	27%	210	210,018	28	107

## 4.12 References

10 CFR 835. “Occupational Radiation Protection.” Code of Federal Regulations. Online at: [http://www.access.gpo.gov/nara/cfr/waisidx\\_02/10cfr835\\_02.html](http://www.access.gpo.gov/nara/cfr/waisidx_02/10cfr835_02.html)

40 CFR 50. “National Primary and Secondary Ambient Air Quality Standards.” Code of Federal Regulations. Online at: [http://www.access.gpo.gov/nara/cfr/waisidx\\_01/40cfr50\\_01.html](http://www.access.gpo.gov/nara/cfr/waisidx_01/40cfr50_01.html)

40 CFR 61, Subpart H. “National Emission Standards for Radionuclides Other Than Radon from Department of Energy Facilities.” Code of Federal Regulations.

40 CFR 81. “Designation of Areas for Air Quality Planning Purposes.” Code of Federal Regulations. Online at: [http://www.access.gpo.gov/nara/cfr/waisidx\\_01/40cfr81\\_01.html](http://www.access.gpo.gov/nara/cfr/waisidx_01/40cfr81_01.html)

50 CFR 17. “Endangered and Threatened Wildlife and Plants.” Code of Federal Regulations. Online at: [http://www.access.gpo.gov/nara/cfr/waisidx\\_01/50cfr17\\_01.html](http://www.access.gpo.gov/nara/cfr/waisidx_01/50cfr17_01.html)

59 FR 7629. “Executive Order 12898 of February 11, 1994: Federal Actions to Address Environmental Justice in Minority Populations and Low-Income Populations.” *Federal Register* (February 16, 1994).

64 FR 61615. “Record of Decision: Hanford Comprehensive Land-Use Plan Environmental Impact Statement (HCP EIS).” *Federal Register* (November 12, 1999).

Online at: <http://www.gpoaccess.gov/fr/index.html>

65 FR 37253. “Establishment of the Hanford Reach National Monument.” Proclamation 7319 of June 9, 2000 by the President of the United States of America. *Federal Register* (June 9, 2000).

Online at: <http://www.gpoaccess.gov/fr/index.html>

16 USC 469 et seq. Archaeological and Historic Preservation Act. Online at: <http://www4.law.cornell.edu>

16 USC 470 et seq. National Historic Preservation Act (NHPA) of 1966. Online at: <http://www4.law.cornell.edu>

16 USC 1531-1544. Endangered Species Act (ESA) of 1973. Online at: <http://www4.law.cornell.edu>

25 USC 3001 et seq. Native American Graves Protection and Repatriation Act. Online at: <http://www4.law.cornell.edu>

42 USC 6901 et seq. Resource Conservation and Recovery Act (RCRA) of 1976. Online at: <http://www4.law.cornell.edu>

42 USC 9601 et seq. Comprehensive Environmental Response, Compensation, and Liability Act (CERCLA) of 1980. Online at: <http://www4.law.cornell.edu/uscode>

Airhart, S. P., A. W. Pearson, and J. V. Borghese. 1990. *Borehole Completion Data Package for the 216-S-10 Ditch and Pond*. WHC-MR-0206, Westinghouse Hanford Company, Richland, Washington.

Anderson, J. D. 1990. *A History of the 200 Area Tank Farms*. WHC-MR-0132, Westinghouse Hanford Company, Richland, Washington.

Andrefsky, Jr., W., L. L. Hale, and D. A. Harder. 1996. *1995 WSU Archaeological Block Survey of the Hanford 600 Area*. Project Report No. 29. Center for Northwest Anthropology, Department of Anthropology, Washington State University, Pullman, Washington.

BAER 2000. *24 Command Fire Burn Area Emergency Rehabilitation (BAER) Plan*. Northern States Burned Area Emergency Rehabilitation Team, U.S. Department of the Interior, Washington, D.C.

Bard, J. C. 1997. "Ethnographic/Contact Period (Lewis and Clark 1805 – Hanford Engineer Works 1943) of the Hanford Site, Washington." In *National Register of Historic Places Multiple Property Documentation Form – Historic, Archaeological and Traditional Cultural Properties of the Hanford Site, Washington*. DOE/RL-97-02, Rev. 0, pp. 3.1-3.155, U.S. Department of Energy, Richland Operations Office, Richland, Washington.

Bauer, H. H., and J. J. Vaccaro. 1990. *Estimates of Ground-Water Recharge to the Columbia Plateau Regional Aquifer System, Washington, Oregon, and Idaho for Predevelopment and Current Land-Use Conditions*. Water Resources Investigation Report 88-4108, U.S. Geological Survey, Tacoma, Washington.

Belnap, J., J. H. Kaltenecker, R. Rosentreter, J. Williams, S. Leonard, and D. Eldrige. 2001. *Biological Soil Crusts: Ecology and Management*. Technical Reference 1730-2, Bureau of Land Management, Denver, Colorado. Online at: <http://www.blm.gov/nstc/library/pdf/CrustManual.pdf>

Bergstrom, K. A., J. A. Caggiano, R. W. Cross, J. D. Davies, D. W. Duncan, K. R. Fecht, T. H. Mitchell, S. P. Reidel, and A. C. Rohay. 1983. *Preliminary Interpretation of the Tectonic Stability of the Reference Repository Location, Cold Creek Syncline, Hanford Site*. RHO-BW-ST-19P, Rockwell Hanford Operations, Richland, Washington.

BLS. 2002. *Industry Injury and Illness Data*. Bureau of Labor Statistics, U.S. Department of Labor, Washington, D.C. Online at: <http://www.bls.gov/iif/oshsum.htm>

Brandt, C. A., C. E. Cushing, W. H. Rickard, N. A. Cadoret, and R. Mazaika. 1993. *Biological Resources of the 300-FF-5 Operable Unit*. WHC-SD-EN-TI-121, Westinghouse Hanford Company, Richland, Washington.

Brown, R. E. 1979. *A Review of Water-Well Data from the Unconfined Aquifer in the Eastern and Southern Parts of the Pasco Basin*. RHO-BWI-C-56, Rockwell Hanford Operations, Richland, Washington.

Cadwell, L. L. 1994. *Wildlife Studies on the Hanford Site: 1993 Highlights Report*. PNL-9380, Pacific Northwest Laboratory, Richland, Washington.

Census. 2000a. *People and Families in Poverty by Selected Characteristics; 1999 and 2000*. Data from the U.S. Census Bureau, March 1999 and 2000 Current Population Surveys. Bureau of the Census, U.S. Department of Commerce, Washington, D.C. Online at: <http://www.census.gov/prod/2001pubs/p60-214.pdf>

Census. 2000b. *Poverty 1999. Poverty Thresholds in 1999, by Size of Family and Number of Related Children Under 18 Years*. Last revised September 26, 2000. Bureau of the Census, U.S. Department of Commerce, Washington, D.C. Online at: <http://www.census.gov/hhes/poverty/poverty99/pv99thrs.html>

Census. 2001a. *Poverty Thresholds in 2000, by Size of Family and Number of Related Children Under 18 Years*. Last revised January 29, 2001. U.S. Bureau of the Census, U.S. Department of Commerce, Washington, D.C. Online at: <http://www.census.gov>

Census. 2001b. *Census 2000 Redistricting Data (P.L. 94-171) Summary File – Washington*. U.S. Bureau of the Census, U.S. Department of Commerce, Washington, D.C. Online at: <http://www.census.gov>

Census. 2001c. *Census 2000 Redistricting Data (P.L. 94-171) Summary File – Oregon*. U.S. Bureau of the Census, U.S. Department of Commerce, Washington, D.C. Online at: <http://www.census.gov>

Census. 2002. *Table QT P-34 Poverty Status of Individuals*. Census Summary File 3 (SF3) Sample Data. American FactFinder. U.S. Bureau of the Census, U.S. Department of Commerce, Washington, D.C. Online at: <http://factfinder.census.gov/servlet/BasicFactsServlet>

Census. 2003. *Geographic Comparison Table, Washington State Counties*. U.S. Census Bureau, Census 2000 Redistricting Data (Public Law 94-171) Summary File, Matrices PL1 and PL2. U.S. Bureau of the Census, U.S. Department of Commerce, Washington, D.C. Online at: [http://factfinder.census.gov/servlet/BasicFactsTable?\\_lang=en&\\_vt\\_name=DEC\\_2000\\_PL\\_U\\_GCTPL\\_ST2&\\_geo\\_id=04000US53](http://factfinder.census.gov/servlet/BasicFactsTable?_lang=en&_vt_name=DEC_2000_PL_U_GCTPL_ST2&_geo_id=04000US53)

CEQ. 1997. *Environmental Justice. Guidance Under the National Environmental Policy Act*. Council on Environmental Quality, Executive Office of the President, Washington, D.C. Online at: <http://ceq.eh.doe.gov/nepa/regs/ej/justice.pdf>

Chatters, J. C. 1982. "Prehistoric Settlement and Land Use in the Dry Columbia Basin." *Northwest Anthropological Research Notes*, 16(2):125-147.

Chatters, J. C., and N. A. Cadoret. 1990. *Archeological Survey of the 200-East and 200-West Areas, Hanford Site, Washington*. PNL-7264, Pacific Northwest Laboratory, Richland, Washington.

Chatters, J. C., N. A. Cadoret, and P. E. Minthorn. 1990. *Hanford Cultural Resources Laboratory Annual Report for Fiscal Year 1989*. PNL-7362, Pacific Northwest Laboratory, Richland, Washington.



Chatters, J. C., and H. A. Gard. 1992. *Hanford Cultural Resources Laboratory Annual Report for Fiscal Year 1991*. PNL-8101, Pacific Northwest Laboratory, Richland, Washington.

Chatters J. C., H. A. Gard, and P. E. Minthorn. 1991. *Hanford Cultural Resources Laboratory Annual Report for Fiscal Year 1990*. PNL-7853, Pacific Northwest Laboratory, Richland, Washington.

Chatters, J. C., H. A. Gard, and P. E. Minthorn. 1992. *Fiscal Year 1991 Report on Archaeological Surveys of the 100 Areas, Hanford Site, Washington*. PNL-8143, Pacific Northwest Laboratory, Richland, Washington.

CNSS. 2001. On-Line Earthquake Catalog. Council of the National Seismic System. Online at: <http://www.quake.geo.berkeley.edu/cnss>

Cole, C. R., S. K. Wurstner, M. P. Bergeron, M. D. Williams, and P. D. Thorne. 1997. *Three-Dimensional Analysis of Future Groundwater Flow Conditions and Contaminant Plume Transport in the Hanford Site Unconfined Aquifer System: FY 1996 and 1997 Status Report*. PNNL-11801, Pacific Northwest National Laboratory, Richland, Washington.

Cushing, C. E., and E. G. Wolf. 1982. "Organic Energy Budget of Rattlesnake Springs, Washington." *American Midland Naturalist*, 107(2):404-407.

Cushing, C. E., and E. G. Wolf. 1984. "Primary Production in Rattlesnake Springs, a Cold Desert Spring-Stream." *Hydrobiologia*, 114:229-236.

Daubenmire, R. 1970. *Steppe Vegetation of Washington*. Technical Bulletin 62, Washington Agricultural Experiment Station, Washington State University, Pullman, Washington.

Daugherty, R. D. 1952. "Archaeological Investigations of O'Sullivan Reservoir, Grant County, Washington." *American Antiquity*, 17:374-383.

Delaney, C. D., K. A. Lindsey, and S. P. Reidel. 1991. *Geology and Hydrology of the Hanford Site: A Standardized Text for Use in Westinghouse Hanford Company Documents and Reports*. WHC-SD-ER-TI-0003, Rev. 0, Westinghouse Hanford Company, Richland, Washington.

Dirkes, R. L. 1993. *Columbia River Monitoring: Distribution of Tritium in Columbia River Water at the Richland Pumpouse*. PNL-8531, Pacific Northwest Laboratory, Richland, Washington.

DOC. 2001. *Regional Economic Information System (REIS)*. Bureau of Economic Analysis, U.S. Department of Commerce, Washington, D.C. Online at: <http://www.bea.doc.gov/bea/regional/reis>

DOE. 1986. *Environmental Assessment, Reference Repository Location, Hanford Site, Washington*. DOE/RW-0070, U.S. Department of Energy, Office of Civilian Radioactive Waste Management, Washington, D.C.

- DOE. 1988. *Consultation Draft: Site Characterization Plan, Reference Repository Location, Hanford Site, Washington*. DOE/RW-0164, U.S. Department of Energy, Washington, D.C.
- DOE. 1991. *Draft Environmental Impact Statement for the Siting, Construction, and Operation of New Production Reactor Capacity*. DOE/EIS-0144D, Vol. 4, Appendix E, U.S. Department of Energy, Washington, D.C.
- DOE. 1993. *Radiation Protection of the Public and the Environment*. DOE Order 5400.5, U.S. Department of Energy, Washington, D.C. Online at: <http://www.directives.doe.gov>
- DOE. 1999. *Final Hanford Comprehensive Land-Use Plan Environmental Impact Statement*. DOE/EIS-0222-F, U.S. Department of Energy, Richland, Washington. Online at: <http://www.hanford.gov/eis/hraeis/maintoc.htm>
- DOE. 2000. *U.S. Department of Energy American Indian and Alaska Native Tribal Government Policy*. U.S. Department of Energy, Washington, D.C. Online at: <http://www.ci.doe.gov/indianbk.pdf>
- DOE. 2001a. *Environmental Assessment – Use of Existing Borrow Areas, Hanford Site, Richland, Washington*. DOE/EA-1403, U.S. Department of Energy, Richland Operations Office, Richland, Washington. Online at: <http://www.hanford.gov/netlib/ea.asp>
- DOE. 2001b. *Supplement Analysis for the Tank Waste Remediation System*. DOE/EIS-0189-SA3, U.S. Department of Energy, Richland Operations Office, Richland, Washington.
- DOE. 2002. *DOE Computerized Accident/Incident Reporting System (CAIRS)*. Online at: <http://tis.eh.doe.gov/cairs> (Data downloaded June 2002)
- DOE. 2003. *The U.S. Department of Energy's Web Page for Information on Occupational Radiation Exposure*. Online at: <http://rems.eh.doe.gov>
- DOE-RL. 1996. *Programmatic Agreement Among the U.S. Department of Energy Richland Operations Office, The Advisory Council on Historic Preservation, and The Washington State Historic Preservation Office for the Maintenance, Deactivation, Alteration, and Demolition of the Built Environment on the Hanford Site, Washington*. DOE/RL-96-77, U.S. Department of Energy, Richland Operations Office, Richland, Washington. Online at: <http://www.hanford.gov/docs/96eap154/96eap154.htm>
- DOE-RL. 1997. *Waste Site Grouping for 200 Areas Soil Investigations*. DOE/RL-96-81, U.S. Department of Energy, Richland Operations Office, Richland, Washington.
- DOE-RL. 1998. *Hanford Site Manhattan Project and Cold War Era Historic District Treatment Plan*. DOE/RL-97-56, Rev. 1, U.S. Department of Energy, Richland Operations Office, Richland, Washington. Online at: <http://www.hanford.gov/docs/r197-56/r197-56.htm>

DOE-RL. 1999. *Groundwater/Vadose Zone Integration Project Background Information and State of Knowledge*. DOE/RL-98-48, Vol. II, Rev. 0, U.S. Department of Energy, Richland Operations Office, Richland, Washington.

DOE-RL. 2001. *Hanford Site Biological Resources Management Plan*. DOE/RL 96-32, Rev. 0, U.S. Department of Energy, Richland Operations Office, Richland, Washington.

DOE-RL. 2002. *History of the Plutonium Production Facilities at the Hanford Site Historic District, 1943-1990*. DOE/RL-97-1047, U.S. Department of Energy, Richland Operations Office, Richland, Washington. Online at: <http://www.hanford.gov/docs/rl-97-1047/index.pdf>

DOE-RL. 2003a. *Hanford Cultural Resources Management Plan*. DOE/RL-98-10, Rev 0, U.S. Department of Energy, Richland Operations Office, Richland, Washington.

DOE-RL. 2003b. *Hanford Site Biological Resources Mitigation Strategy*. DOE/RL-96-88, Rev 0, U.S. Department of Energy, Richland Operations Office, Richland, Washington. Online at: <http://www.pnl.gov/ecology/ecosystem/Docs/BRMiS.pdf>

DOE and Ecology. 1996. *Tank Waste Remediation System, Hanford Site, Richland, Washington, Final Environmental Impact Statement*. DOE/EIS-0189, U.S. Department of Energy, Richland Operations Office, Richland, Washington and Washington State Department of Ecology, Olympia, Washington.

DOI. 1994. *Hanford Reach of the Columbia River: Comprehensive River Conservation Study and Environmental Impact Statement - Final*. Volumes I and II. U.S. Department of Interior, Washington, D.C.

DOL. 2001. *Domestic Agricultural In-Season Farm Labor Report*. Monthly Farm Labor Abstracts, January-December 2001. Washington State Employment Security Department for the U.S. Department of Labor, Olympia, Washington.

Dorian, J. J., and V. R. Richards. 1978. *Radiological Characterization of the Retired 100 Areas*. UNI-946, United Nuclear Industries, Inc., Richland, Washington.

EPA. 1994. *Federal Facility Compliance Agreement for Radionuclides NESHAP*, for the U.S. Department of Energy, Richland Operations Office, Richland, Washington. U.S. Environmental Protection Agency, Region 10, Seattle, Washington.

Fayer, M. J., and T. B. Walters. 1995. *Estimated Recharge Rates at the Hanford Site*. PNL-10285, Pacific Northwest Laboratory, Richland, Washington.

Fitzner, R. E., and R. H. Gray. 1991. "The Status, Distribution, and Ecology of Wildlife on the U.S. DOE Hanford Site: A Historical Overview of Research Activities." *Environ. Monit. Assess.*, 18:173-202.

Frankel, A., C. Mueller, T. Barnhard, D. Perkins, E. V. Leyendecker, N. Dickman, S. Hanson, and M. Hooper. 1996. *National Seismic-Hazard Maps: Documentation June 1996*. U.S. Geological Survey Open-File Report 96-532, Denver, Colorado.

Online at: <http://geohazards.cr.usgs.gov/eq/hazmapsdoc/Junedoc.pdf>

FWS. 2002. *Birds of Conservation Concern 2002*. U.S. Fish and Wildlife Service, Division of Migratory Bird Management, Arlington, Virginia.

Online at: <http://migratorybirds.fws.gov/reports/bcc2002.pdf>

Gaines, W. L. 1987. *Secondary Production of Benthic Insects in Three Cold Desert Streams*. PNL-6286, Pacific Northwest Laboratory, Richland, Washington.

Gard, H. A., and R. M. Poet. 1992. *Archaeological Survey of the McGee Ranch Vicinity, Hanford Site, Washington*. PNL-8186, Pacific Northwest Laboratory, Richland, Washington.

Gee, G. W., and P. R. Heller. 1985. *Unsaturated Water Flow at the Hanford Site: A Review of Literature and Annotated Bibliography*. PNL-5428, Pacific Northwest Laboratory, Richland, Washington.

Gee, G. W., M. J. Fayer, M. L. Rockhold, and M. D. Campbell. 1992. "Variation in Recharge at the Hanford Site." *Northwest Sci.*, 66(4):237-250.

Gephart, R. E. 1999. *A Short History of Plutonium Production and Nuclear Waste Generation, Storage, and Release at the Hanford Site*. PNNL-SA-32152, Pacific Northwest National Laboratory, Richland, Washington.

Graham, M. J., G. V. Last, and K. R. Fecht. 1984. *An Assessment of Aquifer Intercommunication in the B Pond-Gable Mountain Pond Area of the Hanford Site*. RHO-RE-ST-12P, Rockwell Hanford Operations, Richland, Washington.

Gray, R. H., and D. D. Dauble. 1977. "Checklist and Relative Abundance of Fish Species from the Hanford Reach of the Columbia River." *Northwest Science*, 51(3):208-215.

Hajek, B. F. 1966. *Soil Survey: Hanford Project in Benton County, Washington*. BNWL-243, Pacific Northwest Laboratory, Richland, Washington.

Hall, J. A. (ed.). 1998. *Biodiversity Inventory and Analysis of the Hanford Site, 1997 Annual Report*. The Nature Conservancy of Washington, Seattle, Washington.

Hanlon, B. M. 2001. *Waste Tank Summary Report for Month Ending January 31, 2001*. HNF-EP-0182-154, CH2M Hill Hanford Group, Richland, Washington.

Harris, S. G., and B. L. Harper. 1997. "A Native American Exposure Scenario." *Risk Analysis*, 17(6): 789-795.

Hartman, M. J., ed. 2000. *Hanford Site Groundwater Monitoring: Setting, Sources, and Methods*. PNNL-13080, Pacific Northwest National Laboratory, Richland, Washington. Online at: <http://groundwater.pnl.gov/reports/gwset01/html/start1.htm>

Hartman, M. J., L. F. Morasch, and W. D. Webber, eds. 2001. *Hanford Site Groundwater Monitoring for Fiscal Year 2000*. PNNL-13404, Pacific Northwest National Laboratory, Richland, Washington. Online at: <http://hanford-site.pnl.gov/groundwater/reports/gwrep00/start.htm>

Hartman, M. J., P. E. Dresel, J. W. Lindberg, J. P. McDonald, D. R. Newcomer, and E. C. Thornton. 2002a. *Fiscal Year 2003 Integrated Monitoring Plan for the Hanford Groundwater Monitoring Program*. PNNL-14111, Pacific Northwest National Laboratory, Richland, Washington. Online at: [http://www.pnl.gov/main/publications/external/technical\\_reports/PNNL-14111.pdf](http://www.pnl.gov/main/publications/external/technical_reports/PNNL-14111.pdf)

Hartman, M. J., L. F. Morasch, and W. D. Webber, eds. 2002b. *Hanford Site Groundwater Monitoring for Fiscal Year 2001*. PNNL-13788, Pacific Northwest National Laboratory, Richland, Washington. Online at: <http://groundwater.pnl.gov/reports/gwrep01/start.htm>

Hartman, M. J., L. F. Morasch, and W. D. Webber (eds.). 2003. *Hanford Site Groundwater Monitoring for Fiscal Year 2002*. PNNL-14187, Pacific Northwest National Laboratory, Richland, Washington. Online at: <http://groundwater.pnl.gov/reports/gwrep02/start.htm>

Hartshorn, D. C., S. P. Reidel, A. C. Rohay, and M. M. Valenta. 2001. *Annual Hanford Seismic Report for Fiscal Year 2001*. PNNL-11557-19, Pacific Northwest National Laboratory, Richland, Washington. Online at: [http://www.pnl.gov/main/publications/external/technical\\_reports/pnnl-11557-19.pdf](http://www.pnl.gov/main/publications/external/technical_reports/pnnl-11557-19.pdf)

Hitchcock, C. L., and A. Cronquist. 1973. *Flora of the Pacific Northwest: An Illustrated Manual*. University of Washington Press, Seattle, Washington.

Hoitink, D. J., K. W. Burk, J. V. Ramsdell, and W. J. Shaw. 2002. *Hanford Site Climatological Data Summary 2001 with Historical Data*. PNNL-13859, Pacific Northwest National Laboratory, Richland, Washington. Online at: [http://www.pnl.gov/main/publications/external/technical\\_reports/PNNL-13859.pdf](http://www.pnl.gov/main/publications/external/technical_reports/PNNL-13859.pdf)

Horton, D. G., and R. R. Randall. 2000. *Results of 1999 Spectral Gamma-Ray and Neutron Moisture Monitoring of Boreholes at Specific Retention Facilities in the 200 East Area, Hanford Site*. PNNL-13077, Pacific Northwest National Laboratory, Richland, Washington.

Jenkins, O. P. 1922. *Underground Water Supply of the Region About White Bluffs and Hanford*. Bulletin No. 26, Division of Geology, State of Washington Department of Conservation and Development, Olympia, Washington.

Jensen, E. J. 1987. *An Evaluation of Aquifer Intercommunication Between the Unconfined and Rattlesnake Ridge Aquifers on the Hanford Site*. PNL-6313, Pacific Northwest Laboratory, Richland, Washington.

Johansen, J. R., J. Ashley, and W. R. Rayburn. 1993. "Effects of Rangeland Fire on Soil Algal Crusts in Semiarid Shrub-Steppe of the Lower Columbia Basin and their Subsequent Recovery." *Great Basin Naturalist*, 53(1):73-88.

Jones, T. E., R. Khaleel, D. A. Myers, J. W. Shade, and M. I. Wood. 1998. *Summary and Evaluation of Hanford Site Tank Farm Subsurface Contamination*. HNF-2603, Rev. 0, Lockheed Martin Hanford, Richland, Washington.

Kincaid, C. T., M. P. Bergeron, C. R. Cole, M. D. Freshley, N. L. Hassig, V. G. Johnson, D. I. Kaplan, R. J. Serne, G. P. Streile, D. L. Strenge, P. D. Thorne, L. W. Vail, G. A. Whyatt, and S. K. Wurstner. 1998. *Composite Analysis for Low-Level Waste Disposal in the 200 Areas Plateau of the Hanford Site*. PNNL-11800, Pacific Northwest National Laboratory, Richland, Washington.

Krieger, H. W. 1928. "A Prehistoric Pit House Village Site on the Columbia River at Wahluke, Grant County, Washington." *Proceedings of the United States National Museum*, 73:1-29.

Landeem, D. S., A. R. Johnson, and R. M. Mitchell. 1992. *Status of Birds at the Hanford Site in Southeastern Washington*. WHC-EP-0402, Rev. 1, Westinghouse Hanford Company, Richland, Washington.

Landeem, D. S., M. R. Sackschewsky, and S. Weiss. 1993. *100 Areas CERCLA Ecological Investigations*. WHC-EP-0620, Westinghouse Hanford Company, Richland, Washington.

Last, G. V., and V. H. Rohay. 1993. *Refined Conceptual Model for the Volatile Organic Compounds - Arid Integrated Demonstration and 200 West Area Carbon Tetrachloride Expedited Response Action*. PNL-8597, Pacific Northwest Laboratory, Richland, Washington.

Last, G. V., M. K. Wright, M. E. Crist, N. A. Cadoret, M. V. Dawson, K. A. Simmons, D. W. Harvey, and J. G. Longenecker. 1994. *Hanford Cultural Resources Laboratory Annual Report for Fiscal Year 1993*. PNL-10077, Pacific Northwest Laboratory, Richland, Washington. Online at: <http://www.osti.gov/servlets/purl/10185783-IuDPLj/webviewable/10185783.pdf>

Leonhardy, F. C., and D. G. Rice. 1970. "A Proposed Culture Typology for the Lower Snake River Region, Southeastern Washington." *Northwest Anthropological Research Notes*, 4:1-29.

Link, S. O., B. D. Ryan, J. L. Downs, L. L. Cadwell, J. A. Soll, M. A. Hawke, and J. Ponzetti. 2000. "Lichens and Mosses on Shrub-steppe Soils in Southeastern Washington." *Northwest Science*, Vol. 74, No. 1.

LMEA. 2001a. *Covered Employment and Wages by Industry, 2001*. Washington State Labor Market and Economic Analysis, Olympia, Washington. Online at: <http://www.wa.gov/esd/lmea/labmrkt/emp/emphome.htm>

LMEA. 2001b. *Nonagricultural Wage and Salary Employment (2001-2000)*. Washington State Labor Market and Economic Analysis, Olympia, Washington. Online at: <http://www.wa.gov/esd/lmea/curremp/benchmar/benchmar.htm>

Morgan, V. 1981. *Archaeological Reconnaissance of the North Richland Toll Bridge and Associated Access Roads (L6909)*. Archaeological and Historical Services, Eastern Washington University, Cheney, Washington.

NCRP. 1987. *Ionizing Radiation Exposure of the Population of the United States*. NCRP Report No. 93, National Council on Radiation Protection and Measurements, Bethesda, Maryland.

Neitzel, D. A. (ed.). 2001. *Hanford Site National Environmental Policy Act (NEPA) Characterization*. PNNL-6415, Rev. 13, Pacific Northwest National Laboratory, Richland, Washington.

Neitzel, D. A. (ed.). 2002a. *Hanford Site National Environmental Policy Act (NEPA) Characterization*. PNNL-6415, Rev. 14, Pacific Northwest National Laboratory, Richland, Washington. Online at: <http://www.pnl.gov/ecology/pubs/PDFs/NEPARev14.pdf>

Neitzel, D. A. 2002b. Personal communication with Debbie Hickey (Richland School District), Connie Bailey (Pasco School District), and Maggie Mahan (Kennewick School District). (See Volume II of this EIS, Appendix O.)

Newcomb, R. C., J. R. Strand, and F. J. Frank. 1972. *Geology and Ground-Water Characteristics of the Hanford Reservation of the U.S. Atomic Energy Commission, Washington*. Professional Paper 717, U.S. Geological Survey, Washington, D.C.

NRC. 1982. *Draft Environmental Statement Related to the Construction of Skagit/Hanford Nuclear Project, Units 1 and 2. Docket Nos. STN-50-522 and STN 50-523*. Prepared by Puget Sound Power & Light Company, Pacific Power and Light Company, the Washington Water Power Company, and Portland General Electric Company. NUREG-0894, U.S. Nuclear Regulatory Commission, Washington, D.C.

OFM. 2001. *Median Household Income by County: 1989 to 2001 and Forecast for 2002*. Office of Financial Management, Forecasting Division, Olympia, Washington. Online at: <http://www.ofm.wa.gov/pop/poptrends/poptrends.pdf>

OFM. 2003. *Intercensal and Postcensal Estimates of County Population by Age and Sex, 1980-2002*. Office of Financial Management, Forecasting Division, Olympia, Washington. Online at: <http://www.ofm.wa.gov/pop/coagemf/index.htm>

OSPI. 2002. *2001-2002 Public and Private School Enrollment Summary (Report 1345A-by county, district, building, and ethnicity)*. Office of Superintendent of Public Instruction, Olympia, Washington. Online at: <http://www.k12.wa.us/dataadmin>

OTED. 2002. *Washington State Travel Impacts & Visitor Volume 1991-2002p*. Washington State Office of Trade and Economic Development, Washington State Tourism Division, Olympia, Washington. Online at: [http://www.experiencewashington.com/images/pdf/R\\_ImpactStatewide91-2002p.pdf](http://www.experiencewashington.com/images/pdf/R_ImpactStatewide91-2002p.pdf)

Perteet Engineering, Inc., Thomas/Lane and Associates, Inc., and SCM Consultants, Inc. 2001. *The Impact of the Waste Treatment Plant Project on the Hanford Communities*. Prepared by Perteet Engineering, Inc., Everett, Washington for the Hanford Communities, Richland, Washington.

Poston, T. M., K. L. Price, and D. R. Newcomer. 1991. *An Evaluation of the Chemical, Radiological, and Ecological Conditions of West Lake on the Hanford Site*. PNL-7662, Pacific Northwest Laboratory, Richland, Washington.

Poston, T. M., R. W. Hanf, R. L. Dirkes, and L. F. Morasch. 2001. *Hanford Site Environmental Report for Calendar Year 2000*. PNNL-13487, Pacific Northwest National Laboratory, Richland, Washington. Online at: <http://www.hanford.gov/docs/annualrp00>

Poston, T. M., R. W. Hanf, R. L. Dirkes, and L. F. Morasch. 2002. *Hanford Site Environmental Report for Calendar Year 2001*. PNNL-13910, Pacific Northwest National Laboratory, Richland, Washington. Online at: <http://hanford-site.pnl.gov/envreport/2001/index.htm>

Price, K. R., J. M. Carlile, R. L. Dirkes, R. E. Jaquish, M. S. Trevathan, and R. K. Woodruff. 1986. *Environmental Monitoring at Hanford for 1984. Supplement*. PNL-5407 Suppl., Pacific Northwest Laboratory, Richland, Washington.

Ramsdell, J. V., and G. L. Andrews. 1986. *Tornado Climatology of the Contiguous United States*. NUREG/CR-4461, U.S. Nuclear Regulatory Commission, Washington, D.C.

RCW 36.70A. "Growth Management – Planning By Selected Counties And Cities." Revised Code of Washington, Olympia Washington. Online at: <http://www.leg.wa.gov/RCW/index.cfm?fuseaction=chapterdigest&chapter=36.70A>

Reidel, S. P., K. A Lindsey, and K. R. Fecht. 1992. *Field Trip Guide to the Hanford Site*. WHC-MR-0391, Westinghouse Hanford Company, Richland, Washington.

Relander, C. 1956. *Drummers and Dreamers*. Caxton Printers, Caldwell, Idaho.

Rice, D. G. 1968a. *Archaeological Reconnaissance: Ben Franklin Reservoir Area, 1968*. Washington State University, Laboratory of Anthropology, Pullman, Washington.

Rice, D. G. 1968b. *Archaeological Reconnaissance: Hanford Atomic Works*. U.S. Atomic Energy Commission, National Park Service and Washington State University, Pullman, Washington.

Rickard, W. H., and L. E. Rogers. 1983. "Industrial Land Use and the Conservation of Native Biota in the Shrub-Steppe Region of Western North America." *Environmental Conservation*, 10:205-211.



Rohay, A. C. 1989. "Earthquake Recurrence Rate Estimates for Eastern Washington and the Hanford Site." In *Proceedings, Second DOE Natural Phenomena Hazards Mitigation Conference*, CONF-8910192, pp. 272-281, October 3-5, 1989, Knoxville, Tennessee, sponsored by U.S. Department of Energy Headquarters, Office of Nuclear Safety, NTIS, Springfield, Virginia.

Rohay, V. J. 1999. *Performance Evaluation Report for Soil-Vapor Extraction Operations at the Carbon Tetrachloride Site, February 1992 - September 1998*. BHI-00720, Rev. 3, Bechtel Hanford Inc., Richland, Washington.

Sackschewsky, M. R. 2002. *Blanket Biological Review for General Maintenance Activities within Active Burial Grounds, 200 East and 200 West Areas, ECR #2002-200-034*. PNNL-14133, Pacific Northwest National Laboratory, Richland, Washington.

Sackschewsky, M. R. 2003. *Biological Review for the Hanford Solid Waste EIS - Borrow Area C (600 Area), Stockpile and Conveyance Road Area (600 Area), Environmental Restoration Disposal Facility (ERDF) (600 Area), Central Waste Complex (CWC) Expansion (200 West), 218-W-5 Expansion Area (200 West), New Waste Processing Facility (200 West), Undeveloped Portion of 218-W-4C (200 West), Western Half & Northeastern Corner of 218-W-6 (200 West), Disposal Facility Near Plutonium-Uranium Extraction (Purex) Facility (200 East), ECR #2002-600-012b*. PNNL-14233, Pacific Northwest National Laboratory, Richland, Washington.

Sackschewsky, M. R., D. S. Landeen, G. I. Baird, W. H. Rickard, and J. L. Downs. 1992. *Vascular Plants of the Hanford Site*. WHC-EP-0554, Westinghouse Hanford Company, Richland, Washington.

Schalla, R., B. N. Bjornstad, and S. M. Narbutovskih. 2000. *Subsurface Conditions Description of the B-BX-BY Waste Management Area*. HNF-5507, Rev. 0A, CH2M Hill Hanford Group Incorporated, Richland, Washington.

Schmidt, J. W., J. W. Fassett, V. G. Johnson, R. M. Mitchell, B. M. Markes, S. M. McKinney, K. J. Moss, and C. J. Perkins. 1996. *Westinghouse Hanford Company Operational Environmental Monitoring Annual Report, Calendar Year 1995*. WHC-EP-0573-4, Westinghouse Hanford Company, Richland, Washington.

Skaggs, R. L., and W. H. Walters. 1981. *Flood Risk Analysis of Cold Creek Near the Hanford Site*. RHO-BWI-C-120, Rockwell Hanford Operations, Richland, Washington.

Smith, W. C., M. L. Uebelacker, T. E. Eckert, and L. J. Nickel. 1977. *An Archaeological Historical Survey of the Proposed Transmission Power Line Corridor from Ashe Substation, Washington to Pebble Springs Substation, Oregon*. Washington Archaeological Research Center Project Report 42, Washington State University, Pullman, Washington.

Soll, J. A., and C. Soper (eds). 1996. *Biodiversity Inventory and Analysis of the Hanford Site, 1995 Annual Report*. The Nature Conservancy of Washington, Seattle, Washington.

Spane, F. A., Jr. 1987. *Fresh-Water Potentiometric Map and Inferred Flow Direction of Ground Water Within the Mabton Interbed, Hanford Site, Washington State - January 1987*. SD-BWI-TI-335, Rockwell Hanford Operations, Richland, Washington.

Spier, L. 1936. *Tribal Distribution in Washington*. General Series in Anthropology No. 3, George Banta Publishing Co., Menasha, Wisconsin.

Stone, W. A., D. E. Jenne, and J. M. Thorp. 1972. *Climatography of the Hanford Area*. BNWL-1605, Pacific Northwest Laboratories, Richland, Washington.

Stone, W. A., J. M. Thorp, O. P. Gifford, and D. J. Hoitink. 1983. *Climatological Summary for the Hanford Area*. PNL-4622, Pacific Northwest Laboratory, Richland, Washington.

Sturtevant, W. C., and D. E. Walker, Jr. (eds.). 1998. *Handbook of North American Indians, Volume 12: Plateau*. Smithsonian Institution, Washington, D.C.

Tallman, A.M. 1994. *Probabilistic Seismic Hazard Analysis DOE Hanford Site, Washington*. Prepared for Westinghouse Hanford Company. WHC-SD-W236A-TI-002, Geomatrix Consultants for Westinghouse Hanford Company, Richland, Washington.

Tallman, A. M. 1996. *Probabilistic Seismic Hazard Analysis DOE Hanford Site, Washington*. Prepared for Geomatrix Consultants, Inc. WHC-SD-W236A-TI-002, Rev. 1, Westinghouse Hanford Company, Richland, Washington.

TCAR. 2001. *Tri-City Area Housing Statistics*. Tri-City Association of Realtors, Kennewick, Washington. Online at: <http://www.tricityrealtors.com>

Thorne, P. D., and M. A. Chamness. 1992. *Status Report on the Development of a Three-Dimensional Conceptual Model for the Hanford Site Unconfined Aquifer System*. PNL-8332, Pacific Northwest Laboratory, Richland, Washington.

Thorne, P. D., M. A. Chamness, F. A. Spane Jr., V. R. Vermeul, and W. D. Webber. 1993. *Three-Dimensional Conceptual Model for the Hanford Site Unconfined Aquifer System, FY 93 Status Report*. PNL-8971, Pacific Northwest Laboratory, Richland, Washington.

Tiller, B. L. 2000. Personal communication. Pacific Northwest National Laboratory, April 2000. (See Volume II of this EIS, Appendix O.)

Tiller, B. L., G. E. Dagle, L. L. Cadwell, T. M. Poston, and A. Oganessian. 1997. *Investigation of Anatomical Anomalies in Hanford Site Mule Deer*. PNNL-11518, Pacific Northwest National Laboratory, Richland, Washington.

TNC. 1999. *Biodiversity Inventory and Analysis of the Hanford Site: Final Report 1994-1999*. The Nature Conservancy of Washington, Seattle, Washington.

Trafzer, C. E., and R. D. Scheuerman. 1986. *Renegade Tribe: The Palouse Indians and the Invasion of the Inland Pacific Northwest*. Washington State University Press, Pullman, Washington.

TRIDEC. 2002. *Industry and Major Employers Directory*. Tri-Cities Industrial Development Council, Kennewick, Washington. Online at: <http://www.tridec.org>

UWGP. 2001. On-line Earthquake Catalog. University of Washington Geophysics Program, Seattle, Washington. Online at: <http://www.geophys.washington.edu/SEIS>

WAC 173-216. "State Waste Discharge Permit Program." Washington Administrative Code, Olympia, Washington. Online at:  
<http://www.leg.wa.gov/wac/index.cfm?fuseaction=chapterdigest&chapter=173-216>

WAC 173-303. "Dangerous Waste Regulations." Washington Administrative Code, Olympia, Washington. Online at:  
<http://www.leg.wa.gov/wac/index.cfm?fuseaction=chapterdigest&chapter=173-303>

WAC 173-470. "Ambient Air Quality Standards for Particulate Matter." Washington Administrative Code, Olympia, Washington. Online at:  
<http://www.leg.wa.gov/wac/index.cfm?fuseaction=chapterdigest&chapter=173-470>

WAC 173-474. "Ambient Air Quality Standards for Sulfur Oxides." Washington Administrative Code, Olympia, Washington. Online at: <http://www.ecy.wa.gov/biblio/wac173474.html>

WAC 173-480. "Ambient Air Quality Standards and Emission Limits for Radionuclides." Washington Administrative Code, Olympia, Washington. Online at:  
<http://www.leg.wa.gov/wac/index.cfm?fuseaction=chapterdigest&chapter=173-480>

WAC 173-481. "Ambient Air Quality and Environmental Standards for Fluorides." Washington Administrative Code, Olympia, Washington. Online at:  
<http://www.leg.wa.gov/wac/index.cfm?fuseaction=chapterdigest&chapter=173-481>

WAC 232-12-297. "Endangered, threatened, and sensitive wildlife species classification." Washington Administrative Code, Olympia, Washington. Online at:  
<http://www.leg.wa.gov/wac/index.cfm?fuseaction=Section&Section=232-12-297>

WAC 246-247. "Radiation Protection – Air Emissions." Washington Administrative Code, Olympia, Washington. Online at:  
<http://www.leg.wa.gov/wac/index.cfm?fuseaction=chapterdigest&chapter=246-247>

Waite, J. L. 1991. *Tank Wastes Discharged Directly to the Soil at the Hanford Site*. WHC-MR-0227, Westinghouse Hanford Company, Richland, Washington.

Washington Natural Heritage Program. 2002. *Rare Plant Species with Ranks*. Washington Department of Natural Resources, Olympia, Washington. Online at:  
<http://www.wa.gov/dnr/htdocs/fr/nhp/refdesk/fsrefix.htm>

WCRER. 2001a. *Washington State's Housing Market, A Supply/Demand Assessment*. Washington Center for Real Estate Research, Washington State University, Pullman, Washington. Online at:  
<http://www.cbe.wsu.edu/~wcrer/market/HousingMarket.asp>

WCRER. 2001b. *WCRER Apartment Market Survey, Fall 2001*. Washington Center for Real Estate Research, Washington State University, Pullman, Washington. Online at:  
<http://www.cbe.wsu.edu/~wcrer/market/AVS/wcrer00Fallapt.htm>

WDFW Policy M-6001. 1998. *WDFW Policy M-6001*. Washington Department of Fish and Wildlife, Olympia, Washington.

Wright, M. K. 1993. *Fiscal Year 1992 Report on Archaeological Surveys of the 100 Areas, Hanford Site, Washington*. PNL-8819, Pacific Northwest Laboratory, Richland, Washington.

Wurstner, S. K., P. T. Thorne, M. A. Chamness, M. D. Freshley, and M. D. Williams. 1995. *Development of a Three-Dimensional Ground-Water Model of the Hanford Site Unconfined Aquifer System: FY 1995 Status Report*. PNL-10886, Pacific Northwest National Laboratory, Richland, Washington.

Zimmerman, D. A., A. E. Reisenauer, G. D. Black, and M. A. Young. 1986. *Hanford Site Water Table Changes 1950 Through 1980 – Data Observations and Evaluation*. PNL-5506, Pacific Northwest Laboratory, Richland, Washington.

## 5.0 Environmental Consequences

The results of analyses performed to assess potential environmental consequences or impacts of implementing any of the alternative groups are presented in the following sections. For each category of potential environmental impacts considered, brief descriptions of the impact analysis method and the analysis results are given. Details of analytical methods, where applicable, are provided in Volume II (appendixes), as noted within each section. Because the type and level of analysis typically needed for each environmental aspect of interest vary widely, the level of detail in the results presented in the following sections varies commensurate with the nature of the analysis and the potential for consequences associated with that environmental aspect.

In Section 3, Description and Comparison of Alternatives, various alternatives were described for storage, treatment, and disposal of low-level waste (LLW), mixed low-level waste (MLLW), transuranic (TRU) waste, and immobilized low-activity waste (ILAW, the low-activity fraction of tank waste). For purposes of analysis in this section, consequences associated with the alternative actions for each waste type have been combined to provide a consolidated analysis of waste management operations. In the following sections, these consolidated analyses, while retaining the designations corresponding to the various alternatives for each waste type described in Section 3, are analyzed by groups of alternatives. This approach facilitates presentation of impacts for all Hanford Solid Waste Program operations and also is necessary to evaluate facilities that are used to manage more than one type of waste. In these latter consolidated alternative groups, each of the waste types is considered, and the impacts either are analyzed directly or bounded by analysis of similar activities where appropriate.

Unless stated otherwise, the three waste volumes for which evaluations of environmental consequences of the alternatives were made include:

- a Hanford Only waste volume, including the maximum forecast volume for onsite TRU waste
- a Lower Bound waste volume consisting of
  - the Lower Bound volumes for LLW, MLLW (some of which would be received from offsite generators)<sup>(a)</sup>
  - the maximum forecast volume for onsite TRU waste and a Lower Bound waste volume of TRU waste from offsite generators
  - the ILAW volume as defined in Section 3.

---

(a) The amount of the Lower Bound waste volume received from offsite generators would consist of 18 percent Category 1 LLW, 4 percent Category 3 LLW, and 0.2 percent MLLW.

- an Upper Bound waste volume consisting of
  - the Upper Bound volumes for LLW and MLLW (some of which would be received from offsite generators)
  - the maximum forecast volume for onsite TRU waste and an Upper Bound volume of TRU waste from offsite generators
  - the Hanford Site ILAW volume, again, as defined in Section 3.

The alternatives analyzed in detail by groups are described in the following paragraphs. The cumulative impacts are discussed in Section 5.14.

### **Alternative Group A**

Actions included in Alternative Group A are:

- modification of the T Plant Complex to treat some MLLW and for processing and certification of some TRU waste for shipment to the Waste Isolation Pilot Plant (WIPP)
- continued use of existing MLLW treatment capabilities at the Waste Receiving and Processing Facility (WRAP) and other onsite facilities, as appropriate
- in-trench treatment (in-trench grouting, macroencapsulation, etc.) of some contact-handled (CH) or remote-handled (RH) MLLW and non-standard MLLW packages
- treatment of other MLLW and some non-conforming LLW at commercial facilities, followed by return to the Hanford Site for disposal
- continued operation of the WRAP to process and certify some TRU waste for shipment to WIPP
- acquisition and operation of mobile TRU waste processing and certification units (accelerated processing lines [APLs])
- shipment of all TRU waste to WIPP following processing and certification
- disposal of LLW in 200 West Area Low Level Burial Grounds (LLBGs) in unlined trenches that would be deeper and wider than those currently employed
- disposal of MLLW in 200 East Area LLBGs in lined trenches that would be deeper and wider than those currently employed

- disposal of melters in a lined trench in a new disposal facility near the Plutonium-Uranium Extraction (PUREX) Plant in the 200 East Area
- disposal of ILAW in multiple lined trenches in a new disposal facility near the PUREX Plant
- capping LLW trenches in the LLBGs with a Modified Resource Conservation and Recovery Act (RCRA) (42 USC 6901) Subtitle C Barrier
- capping MLLW trenches with a Modified RCRA Subtitle C Barrier
- capping the melter trench with a Modified RCRA Subtitle C Barrier
- capping the ILAW disposal facility with a Modified RCRA Subtitle C Barrier.

### **Alternative Group B**

Actions included in Alternative Group B are listed here. Actions that are the same as those in Alternative Group A are presented in *italics*.

- construction of a new waste processing facility in the 200 Areas to provide onsite capability to treat most MLLW and non-conforming LLW, and for processing and certification of TRU waste for shipment to WIPP (rather than modifying T Plant for that purpose)
- treatment of non-conforming LLW onsite
- treatment of a limited quantity of MLLW at commercial facilities, followed by return to the Hanford Site for disposal
- *continued operation of the WRAP to process and certify some TRU waste for shipment to WIPP*
- *acquisition and operation of mobile TRU waste processing and certification units (APLs)*
- *shipment of all TRU waste to WIPP following processing and certification*
- disposal of LLW in 200 West Area LLBGs in unlined trenches of a design similar to those currently employed
- disposal of MLLW in 200 West Area LLBGs in lined trenches of a design similar to those currently employed until permitted lined trenches are full, then disposed of in 200 East Area LLBGs, again in trenches similar to those currently employed
- disposal of melters in the 200 East Area in a lined melter trench

- disposal of ILAW in multiple lined trenches in the 200 West Area
- capping LLW and MLLW trenches in the LLBGs with a Modified RCRA Subtitle C Barrier
- capping the melter trench with a Modified RCRA Subtitle C Barrier
- capping ILAW burial site with a Modified RCRA Subtitle C Barrier.

### **Alternative Group C**

Actions included in Alternative Group C are listed below. Actions that are the same as those in Alternative Group A are presented in *italics*.

- *modification of the T Plant Complex to provide the capability for treating some MLLW and for processing and certification of some TRU waste for shipment to WIPP*
- *treatment of other MLLW and some non-conforming LLW at commercial facilities, followed by return to the Hanford Site for disposal*
- *continued operation of the WRAP to process and certify some TRU waste for shipment to WIPP*
- *acquisition and operation of mobile TRU waste processing and certification units (APLs)*
- *shipment of all TRU waste to WIPP following processing and certification*
- disposal of LLW in 200 West Area LLBGs in a single unlined expandable trench
- disposal of MLLW in 200 East Area LLBGs in a single lined expandable trench
- *disposal of melters in a lined trench near the PUREX Plant in the 200 East Area*
- disposal of ILAW in a single lined expandable trench near the PUREX Plant
- *capping LLW trenches in the LLBGs with a Modified RCRA Subtitle C Barrier*
- *capping MLLW trenches with a Modified RCRA Subtitle C Barrier*
- *capping the melter trench with a Modified RCRA Subtitle C Barrier*
- *capping the ILAW burial site with a Modified RCRA Subtitle C Barrier.*



## Alternative Group D

Alternative Group D contains three subalternative groupings that depend on the location of disposal. The groupings are denoted by subscripts.

Actions included in Alternative Group D are listed here. Actions that are the same as those in Alternative Group A are presented in *italics*.

- *modification of the T Plant Complex to provide the capability for treating some MLLW and for processing and certification of some TRU waste for shipment to WIPP*
- *treatment of other MLLW and some non-conforming LLW at commercial facilities, followed by return to the Hanford Site for disposal*
- *continued operation of the WRAP to process and certify some TRU waste for shipment to WIPP*
- *acquisition and operation of mobile TRU waste processing and certification units (APLs)*
- *shipment of all TRU waste to WIPP following processing and certification*
- Alternative Group D<sub>1</sub>—disposal of LLW, MLLW, melters, and ILAW in a single, lined, modular combined-use facility in the 200 East Area near the PUREX Plant
- Alternative Group D<sub>2</sub>—disposal of the wastes listed above in a single, lined, modular combined-use facility in the 200 East Area LLBGs
- Alternative Group D<sub>3</sub>—disposal of the wastes listed above in a single, lined, modular combined-use facility at the Environmental Restoration Disposal Facility (ERDF)
- capping the lined combined-use facility with a Modified RCRA Subtitle C Barrier.

## Alternative Group E

Alternative Group E contains three subalternative groupings that depend on the location of disposal and waste type. The groupings are denoted by subscripts.

Actions included in Alternative Group E are as listed below. Actions that are the same as those in Alternative Group A are presented in *italics*.

- *modification of the T Plant Complex to provide the capability for treating some MLLW and for processing and certification of some TRU waste for shipment to WIPP*

- *treatment of other MLLW and some non-conforming LLW at commercial facilities, followed by return to the Hanford Site for disposal*
- *continued operation of the WRAP to process and certify some TRU waste for shipment to WIPP*
- *acquisition and operation of mobile TRU waste processing and certification units (APLs)*
- *shipment of all TRU waste to WIPP following processing and certification*
- Alternative Group E<sub>1</sub>—disposal of LLW and MLLW in a lined modular facility in the 200 East Area LLBGs and disposal of melters and ILAW in a lined, modular facility at ERDF
- Alternative Group E<sub>2</sub>—disposal of LLW and MLLW in a lined, modular facility near the PUREX Plant and disposal of melters and ILAW at ERDF
- Alternative Group E<sub>3</sub>—disposal of LLW and MLLW in a lined, modular facility at ERDF and disposal of melters and ILAW in a lined, modular facility near the PUREX Plant
- capping the lined, modular facilities with a Modified RCRA Subtitle C Barrier.

### **No Action Alternative**

This analysis consists of the combined impacts associated with the No Action Alternative for LLW, MLLW, TRU waste, and ILAW as described in Section 3. The Hanford Only waste volume and the Lower Bound waste volume as defined in Section 3 were used for evaluation purposes. This No Action Alternative consists of continuing current solid waste management practices including implementing the Tank Waste Remediation System (TWRS) Record of Decision (ROD) (62 FR 8693). Actions evaluated as part of the No Action Alternative include those listed below. Actions that are the same as those in Alternative Group A are presented in *italics*.

- treatment of a limited quantity of MLLW at commercial facilities, followed by return to the Hanford Site
- disposal of LLW in the LLBGs in trenches of a design similar to those currently employed
- backfilling LLW trenches to grade with no cap
- disposal of MLLW in the two existing MLLW trenches until full
- capping the two MLLW trenches with a Modified RCRA Subtitle C Barrier
- *processing and certification of some TRU waste at the WRAP for shipment to WIPP*

- *shipment of all TRU waste to WIPP following processing and certification*
- *acquisition and operation of mobile TRU waste processing and certification units (APLs)*
- expansion of the Central Waste Complex (CWC) for storage of some non-conforming LLW, untreated MLLW, treated MLLW that exceeds the capacity of the two existing MLLW trenches, and TRU waste that cannot be certified for shipment to WIPP
- storage of melters on concrete pads at the CWC
- disposal of ILAW as glass cullet in vaults near the PUREX Plant according to the TWRS ROD (62 FR 8693).

Except where otherwise specified, all construction and operations engineering data that form the basis for environmental impact analysis of the alternative groups are provided in the *Hanford Site Solid Waste Management Environmental Impact Statement Technical Information Document* (FH 2004).

A comparison of impacts among the alternative groups appears in Section 3.4.

## 5.1 Land Use

Impacts on land use are considered in terms of commitment of land for a proposed use to the exclusion of other possible uses. Land occupied by LLBGs or other disposal facilities is considered to be permanently committed to the designated use.

In Alternative Groups A, B, C, D, and E, all LLW, MLLW, ILAW, and melters would be disposed of onsite. TRU waste would be shipped to WIPP for disposal. In the No Action Alternative, a substantial amount of the waste would remain in storage because of the lack of appropriate treatment capabilities to permit disposal.

Except for offsite commercial treatment of some MLLW, treatment, storage, and disposal activities associated with Alternative Groups A through E and the No Action Alternative would occur within or between the 200 East and 200 West Areas.<sup>(a)</sup> The 200 Areas occupy about 16 km<sup>2</sup> (6 mi<sup>2</sup>) on the Central Plateau. This area falls under the Industrial-Exclusive designation as defined in the *Final Hanford Comprehensive Land-Use Plan Environmental Impact Statement* (HCP EIS) (DOE 1999). In addition, materials for capping the LLBGs at closure would be obtained from borrow pits in Area C located south of State Route (SR) 240 outside of, but adjacent to, the Fitzner/Eberhardt Arid Lands Ecology Reserve (ALE). The ALE boundary as adjusted in the HCP EIS is included within the Hanford Reach National Monument. Area C consists of about 926 ha (2287 ac) and was previously designated for Conservation (Mining) in the Record of Decision (ROD) for the HCP EIS (64 FR 61615). Excavation would occur over up to about 86 ha (210 ac) to provide capping materials for closure of the HSW disposal sites.

In Alternative Group A, use of land in the LLBGs for disposal of LLW and MLLW in trenches of deeper/wider design would range from 6 ha (15 ac) for the Hanford Only waste volume to 15 ha (37 ac) for the Upper Bound waste volume estimate. This use would be in addition to the 130 ha (321 ac) of land within the LLBGs already occupied by LLW and MLLW (and some retrievably stored TRU waste that would be removed). This additional land use would amount to increases of about 5 to 12 percent. Melters would be disposed of in a 6-ha (15-ac) single expandable lined trench near the PUREX Plant. ILAW would be disposed of near the PUREX Plant in a newly constructed facility occupying about 26 ha (62 ac). The total amount of land permanently used for disposal would range from 168 ha (410 ac) for the Hanford Only waste volume to 178 ha (440 ac) for the Upper Bound waste volume. No new support facilities would be built. However, from 69 to 73 ha (170 to 180 ac) would be temporarily used for excavation of capping materials.

In Alternative Group B, use of land in the LLBGs for disposal of LLW and MLLW in trenches of conventional design would range from 30 ha (74 ac) for the Hanford Only waste volume to 54 ha (130 ac) for the Upper Bound waste volume. This use would be in addition to the 130 ha (321 ac) of land within the LLBGs already occupied by LLW and MLLW (and some retrievably stored TRU waste that would be

---

(a) Installation of mobile accelerated process lines in conjunction with accelerated TRU waste processing and certification would be temporary and would occur within existing CWC buildings or near the points of receipt of TRU waste and would not constitute an important increment in land use.

removed). This additional land use would amount to an increase of about 23 to 41 percent, respectively. ILAW would be disposed of in a newly constructed facility occupying about 26 ha (62 ac) in the CWC expansion area. The total amount of land permanently used for disposal would range from 187 to 210 ha (460 to 520 ac) for the Hanford Only waste volume to the Upper Bound waste volume. A new facility for processing waste would be built and would occupy about 4 ha. From 77 to 86 ha (190 to 210 ac) would be temporarily used for excavation of capping materials.

In Alternative Group C, use of land in the LLBGs for disposal of LLW and MLLW in single expandable trenches by waste type would range from 6 ha (15 ac) for the Hanford Only waste volume to 15 ha (37 ac) for the Upper Bound waste volume (essentially the same as for Alternative Group A). Melters would be disposed of in a 6-ha (15-ac) single expandable lined melter trench near the PUREX Plant. ILAW would be disposed of in a single expandable trench occupying about 8 ha (20 ac) also near the PUREX Plant. The total amount of land permanently used for disposal would range from 151 to 160 ha (370 to 400 ac) for the Hanford Only waste volume to the Upper Bound waste volume. No new treatment facilities would be built. However, from 62 to 66 ha (150 to 160 ac) would be temporarily used for excavation of capping materials.

In Alternative Group D<sub>1</sub>, there would be no use of land in the LLBGs for disposal of LLW and MLLW after the year 2007. LLW, MLLW, ILAW, and melters would be disposed of in a lined modular facility to be built near the PUREX Plant. This facility would occupy from 19 ha (47 ac) for the Hanford Only waste volume to 25 ha (62 ac) for the Upper Bound waste volume estimate. The total amount of land permanently used for disposal would range from 150 to 155 ha (370 to 380 ac) for the Hanford Only waste volume to the Upper Bound waste volume. No new treatment facilities would be built. However, from 62 to 64 ha (150 to 160 ac) would be temporarily used for excavation of capping materials.

In Alternative Group D<sub>2</sub>, LLW, MLLW, ILAW, and melters would be disposed of in a lined modular facility to be built in the 200 East Area LLBGs. The amount of land used would be the same as for Alternative Group D<sub>1</sub>. However, the location of the land would differ from that of Alternative Group D<sub>1</sub>.

In Alternative Group D<sub>3</sub>, LLW, MLLW, ILAW, and melters would be disposed of in a lined modular facility to be built at the ERDF. The amount of land used would be the same as that for Alternative Group D<sub>1</sub>, but land located in a different place would be used.

In Alternative Group E<sub>1</sub>, LLW and MLLW would be disposed of in a lined modular facility to be built in a 200 East Area LLBG. This facility would increase land use in the 200 East Area LLBGs ranging from 5 to 11 ha (12 to 27 ac) for the Hanford Only waste volume to the Upper Bound waste volume. This would represent an increase of from 4 to 8 percent. ILAW and melters would be disposed of in a lined modular facility at the ERDF and would occupy about 14 ha (35 ac). The total amount of land used would be the same as that for Alternative Group D<sub>1</sub>.

In Alternative Group E<sub>2</sub>, LLW and MLLW would be disposed of in a lined modular facility to be built near the PUREX Plant and would occupy the same amount of land as in Alternative Group E<sub>1</sub>. ILAW and melters would be disposed of in a lined modular facility to be built at the ERDF. The size of the latter facility also would be the same as that in Alternative Group E<sub>1</sub>.

In Alternative Group E<sub>3</sub>, LLW and MLLW would be disposed of in a lined modular facility to be built at the ERDF and would occupy the same amount of land as in Alternative Group E<sub>1</sub>. ILAW and melters would be disposed of in a lined modular facility to be built near the PUREX Plant. The size of the latter facility also would be the same as that in Alternative Group E<sub>1</sub>.

In the No Action Alternative, LLW that had been certified for disposal would continue to be disposed of in trenches of current design. MLLW would be disposed of until trenches 31 and 34 in 218-W-5 are full and would thereafter be stored along with LLW that could not be certified for disposal in the CWC. ILAW would be disposed of in vaults occupying about 10 ha (25 ac) near the PUREX Plant. The increase in permanent land use would range from 27 to 29 ha (67 to 72 ac), which includes the 10 ha mentioned above for ILAW, for the Hanford Only waste volume and the Lower Bound waste volume (the Upper Bound waste volume would not be considered in this alternative), an increase of about 20 percent over the 130 ha (320 ac) currently occupied. In addition, about 116 ha (287 ac) would be used for storage at the CWC of wastes for which treatment for disposal would not be available.

Details of land use (including new construction) associated with the HSW EIS alternative groups are provided in Table 5.1 for disposal sites and in Table 5.2 for support facilities.

At most, a total of about 210 ha (440 ac), or 4 percent, of the 5000 ha (13,000 ac) of land designated as Industrial-Exclusive in the ROD for the HCP EIS (64 FR 61615) would be permanently committed to disposal of LLW, MLLW, ILAW, and melters within the scope of activities evaluated in this EIS.

**Table 5.1.** Land Use—Areas Used for Disposal, ha<sup>(a)</sup>

Low Level Burial Ground or Other Disposal Facility	Area Previously Designated for Disposal of HSW	Area Currently Occupied	Alternative Group A LLW & MLLW (Deeper/Wider Trench Design); Melter Trench and ILAW near the PUREX Plant			Alternative Group B LLW & MLLW (Conventional Trench Design); Melter Trench in the 200 East Area; ILAW in the 200 West Area (near the CWC)			Alternative Group C Single Expandable Trenches, LLW in the 200 West Area; MLLW in the 200 East Area; Melter Trench and ILAW near the PUREX Plant			Alternative Group D <sub>1</sub> Lined Modular Facility near the PUREX Plant			Alternative Group D <sub>2</sub> Lined Modular Facility in the 200 East LLBGs		
			Hanford Only Volume	Lower Bound Volume	Upper Bound Volume	Hanford Only Volume	Lower Bound Volume	Upper Bound Volume	Hanford Only Volume	Lower Bound Volume	Upper Bound Volume	Hanford Only Volume	Lower Bound Volume	Upper Bound Volume	Hanford Only Volume	Lower Bound Volume	Upper Bound Volume
<b>Disposal – Low Level Burial Grounds</b>																	
218-W-3A <sup>(b)</sup>	20.4	20.4	20.4	20.4	20.4	20.4	20.4	20.4	20.4	20.4	20.4	20.4	20.4	20.4	20.4	20.4	20.4
218-W-3AE	20	12.2	12.2	12.2	12.2	20	20	20	12.2	12.2	12.2	12.2	12.2	12.2	12.2	12.2	12.2
218-W-4B <sup>(b)</sup>	3.5	3.5	3.5	3.5	3.5	3.5	3.5	3.5	3.5	3.5	3.5	3.5	3.5	3.5	3.5	3.5	3.5
218-W-4C <sup>(b)</sup>	20	4.7	4.7	4.7	4.7	4.7	4.7	4.7	4.7	4.7	4.7	4.7	4.7	4.7	4.7	4.7	4.7
218-W-5	37.2	26	29.4	30.4	35	33	35	37.2	29.4	30.4	35	26	26	26	26	26	26
218-W-5 Exp. <sup>(c)</sup>	202	0	0	0	0	0	0	0	0	0	0	0	0	0	0	0	0
218-W-6	16	0	0	0	0	0	0	7	0	0	0	0	0	0	0	0	0
<b>200 West Area Subtotal</b>	319.1	66.8	70.2	71.2	75.8	81.6	83.6	92.8	70.2	71.2	75.8	66.8	66.8	66.8	66.8	66.8	66.8
218-E-10	36.1	22.7	22.7	22.7	22.7	22.7	23.2	25.6	22.7	22.7	22.7	22.7	22.7	22.7	22.7	22.7	22.7
218-E-12B <sup>(b,d)</sup>	70.1	41	43.6	43.6	47.4	56.3	56.3	65.7	43.6	43.6	47.4	41	41	41	60.0	60.6	65.5
<b>200 East Area Subtotal</b>	106.2	63.7	66.3	66.3	70.1	79	79.5	91.3	66.3	66.3	70.1	63.7	63.7	63.7	82.7	83.3	88.2
<b>LLBG Subtotal</b>	425.3	130.5	136.5	137.5	145.9	160.6	163.1	184.1	136.5	137.5	145.9	130.5	130.5	130.5	149.7	150.2	155
<b>Increase in LLBG Land Use</b>			<b>6.0</b>	<b>7.0</b>	<b>15.4</b>	<b>30.1</b>	<b>32.6</b>	<b>53.6</b>	<b>6.0</b>	<b>7.0</b>	<b>15.4</b>	<b>0</b>	<b>0</b>	<b>0</b>	<b>19.2</b>	<b>19.7</b>	<b>24.5</b>

Table 5.1. (contd)

Low Level Burial Ground or Other Disposal Facility	Area Previously Designated for Disposal of HSW	Area Currently Occupied	Alternative Group A LLW & MLLW (Deeper/Wider Trench Design); Melter Trench and ILAW near the PUREX Plant			Alternative Group B LLW & MLLW (Conventional Trench Design); Melter Trench in the 200 East Area; ILAW in the 200 West Area (near the CWC)			Alternative Group C Single Expandable Trenches, LLW in the 200 West Area; MLLW in the 200 East Area; Melter Trench and ILAW near the PUREX Plant			Alternative Group D <sub>1</sub> Lined Modular Facility near the PUREX Plant			Alternative Group D <sub>2</sub> Lined Modular Facility in the 200 East LLBGs		
			Hanford Only Volume	Lower Bound Volume	Upper Bound Volume	Hanford Only Volume	Lower Bound Volume	Upper Bound Volume	Hanford Only Volume	Lower Bound Volume	Upper Bound Volume	Hanford Only Volume	Lower Bound Volume	Upper Bound Volume	Hanford Only Volume	Lower Bound Volume	Upper Bound Volume
<b>Disposal – Other Areas</b>																	
At ERDF	0	0	0	0	0	0	0	0	0	0	0	0	0	0	0	0	0
Near PUREX	41	0	32	32	32	0	0	0	14	14	14	19.2	19.7	24.5	0	0	0
CWC Expansion	30	0	0	0	0	26	26	26	0	0	0	0	0	0	0	0	0
<b>Total Area Used for HSW Disposal</b>		130.5	168.5	169.5	177.9	186.6	189.1	210.1	150.5	151.5	159.9	149.7	150.2	155.0	149.5	150.1	155.0
<b>Total Increase in Land Use</b>			<b>38.0</b>	<b>39.0</b>	<b>47.4</b>	<b>56.1</b>	<b>58.6</b>	<b>79.6</b>	<b>20.0</b>	<b>21.0</b>	<b>29.4</b>	<b>19.2</b>	<b>19.7</b>	<b>24.5</b>	<b>19.2</b>	<b>19.7</b>	<b>24.5</b>



Table 5.1. (contd)

Low Level Burial Ground or Other Disposal Facility	Area Previously Designated for Disposal of HSW	Area Currently Occupied	Alternative Group D <sub>3</sub> Lined Modular Facility at ERDF			Alternative Group E <sub>1</sub> Lined Modular Facilities LLW & MLLW in the 200 East Area LLBGs, ILAW & Melters at ERDF			Alternative Group E <sub>2</sub> Lined Modular Facilities LLW & MLLW near PUREX, ILAW & Melters at ERDF			Alternative Group E <sub>3</sub> Lined Modular Facilities LLW&MLLW at ERDF, ILAW & Melters near PUREX			No Action Alternative. Non-Disposable Waste Stored in the CWC; Melters Stored on Concrete Pads at the CWC	
			Hanford Only Volume	Lower Bound Volume	Upper Bound Volume	Hanford Only Volume	Lower Bound Volume	Upper Bound Volume	Hanford Only Volume	Lower Bound Volume	Upper Bound Volume	Hanford Only Volume	Lower Bound Volume	Upper Bound Volume	Hanford Only Volume	Lower Bound Volume
<b>Low Level Burial Grounds</b>																
218-W-3A <sup>(b)</sup>	20.4	20.4	20.4	20.4	20.4	20.4	20.4	20.4	20.4	20.4	20.4	20.4	20.4	20.4	20.4	20.4
218-W-3AE	20	12.2	12.2	12.2	12.2	12.2	12.2	12.2	12.2	12.2	12.2	12.2	12.2	12.2	20	20
218-W-4B <sup>(b)</sup>	3.5	3.5	3.5	3.5	3.5	3.5	3.5	3.5	3.5	3.5	3.5	3.5	3.5	3.5	3.5	3.5
218-W-4C <sup>(b)</sup>	20	4.7	4.7	4.7	4.7	4.7	4.7	4.7	4.7	4.7	4.7	4.7	4.7	4.7	4.7	4.7
218-W-5	37.2	26	26	26	26	26	26	26	26	26	26	26	26	26	30.8	32.2
218-W-5 Exp <sup>(c)</sup>	202	0	0	0	0	0	0	0	0	0	0	0	0	0	0	0
218-W-6	16	0	0	0	0	0	0	0	0	0	0	0	0	0	0	0
<b>200 West Area Subtotal</b>	319.1	66.8	66.8	66.8	66.8	66.8	66.8	66.8	66.8	66.8	66.8	66.8	66.8	66.8	79.4	80.8
218-E-10	36.1	22.7	22.7	22.7	22.7	22.7	22.7	22.7	22.7	22.7	22.7	22.7	22.7	22.7	23.2	23.2
218-E-12B <sup>(b,d)</sup>	70.1	41	41	41	41	46.2	46.7	51.5	41	41	41	41	41	41	45	45
<b>200 East Area Subtotal</b>	106.2	63.7	63.7	63.7	63.7	68.9	69.4	74.2	63.7	63.7	63.7	63.7	63.7	63.7	68.2	68.2
<b>LLBG Subtotal</b>	425.3	130.5	130.5	130.5	130.5	135.7	136.2	141	130.5	130.5	130.5	130.5	130.5	130.5	147.6	149
<b>Increase in LLBG Land Use</b>			<b>0</b>	<b>0</b>	<b>0</b>	<b>5.2</b>	<b>5.7</b>	<b>10.5</b>	<b>0</b>	<b>0</b>	<b>0</b>	<b>0</b>	<b>0</b>	<b>0</b>	<b>17.1</b>	<b>18.5</b>

Table 5.1. (contd)

Low Level Burial Ground or Other Disposal Facility	Area Previously Designated for Disposal of HSW	Area Currently Occupied	Alternative Group D <sub>3</sub> Lined Modular Facility at ERDF			Alternative Group E <sub>1</sub> Lined Modular Facilities LLW & MLLW in 200 East Area LLBGs, ILAW & Melters at ERDF			Alternative Group E <sub>2</sub> Lined Modular Facilities LLW & MLLW near PUREX, ILAW & Melters at ERDF			Alternative Group E <sub>3</sub> Lined Modular Facilities LLW&MLLW at ERDF, ILAW & Melters near PUREX			No Action Alternative Non-Disposable Waste Stored in the CWC; Melters Stored on Concrete Pads at the CWC	
			Hanford Only Volume	Lower Bound Volume	Upper Bound Volume	Hanford Only Volume	Lower Bound Volume	Upper Bound Volume	Hanford Only Volume	Lower Bound Volume	Upper Bound Volume	Hanford Only Volume	Lower Bound Volume	Upper Bound Volume	Hanford Only Volume	Lower Bound Volume
<b>Other Disposal Areas</b>																
At ERDF	0	0	19.2	19.7	24.5	14	14	14	14	14	14	5.0	5.6	10.5	0	0
Near PUREX	41	0	0	0	0	0	0	0	5.0	5.6	10.5	14	14	14	10	10
CWC Expansion	30	0	0	0	0	0	0	0	0	0	0	0	0	0	0	0
<b>Total Area Used for HSW Disposal</b>			149.7	150.2	155.0	149.7	150.2	155.0	149.5	150.1	155.0	149.5	150.1	155.0	157.6	159.0
<b>Total Increase in Land Used</b>			<b>19.2</b>	<b>19.7</b>	<b>24.5</b>	<b>19.2</b>	<b>19.7</b>	<b>24.5</b>	<b>19.2</b>	<b>19.2</b>	<b>24.5</b>	<b>19.2</b>	<b>19.7</b>	<b>24.5</b>	<b>27.1</b>	<b>28.5</b>
<p>(a) To obtain areas in acres, multiply hectares (ha) by 2.47. Actual assignment of disposal areas to a particular LLBG would depend on operational efficiency.</p> <p>(b) Area contains some retrievably stored TRU waste.</p> <p>(c) 218-W-5 Exp. is a contingency expansion of the 218-W-5 Burial Ground for operational flexibility.</p> <p>(d) Trench 94 in 218-E-12B consisting of about 7.4 ha (18 ac) is for disposal of decommissioned U.S. Naval reactor compartments and is included in the area designated. A like area is also included for future expansion of reactor compartment disposal (a total of 20.4 ha). Disposal of these reactor compartments was addressed in other NEPA documents (Navy 1984, 1996).</p>																

**Table 5.2.** Land Use—Areas of HSW Treatment and Storage Facilities, ha<sup>(a)</sup>

Facility	Area Previously Designated for HSW Support Facility	Area Currently Occupied	Alternative Group A <sup>(b)</sup> LLW & MLLW (Deeper/Wider Trench Design); Melter Trench and ILAW near PUREX			Alternative Group B LLW & MLLW (Conventional Trench Design); Melter Trench in the 200 East Area; ILAW in the 200 West Area (near the CWC)			Alternative Group C Single Expandable Trenches, LLW in the 200 West Area; MLLW in the 200 East Area; Melter Trench and ILAW near PUREX			Alternative Groups D&E Lined Modular Facilities			No Action Alternative <sup>(c)</sup> Non-Disposable Waste Stored in the CWC; Melters Stored on Concrete Pads at the CWC	
			Hanford Only Volume	Lower Bound Volume	Upper Bound Volume	Hanford Only Volume	Lower Bound Volume	Upper Bound Volume	Hanford Only Volume	Lower Bound Volume	Upper Bound Volume	Hanford Only Volume	Lower Bound Volume	Upper Bound Volume	Hanford Only Volume	Lower Bound Volume
CWC	86	50	50	50	50	50	50	50	50	50	50	50	50	50	86	86
CWC Expansion Area	30	0	0	0	0	0	0	0	0	0	0	0	0	0	23	30
WRAP	4	4	4	4	4	4	4	4	4	4	4	4	4	4	4	4
NWPF <sup>(d)</sup>	0	0	0	0	0	4	4	4	0	0	0	0	0	0	0	0
T Plant Complex	8	8	8	8	8	8	8	8	8	8	8	8	8	8	8	8
ETF <sup>(e)</sup>	15	15	15	15	15	15	15	15	15	15	15	15	15	15	15	15
LERF <sup>(f)</sup>	50	50	50	50	50	50	50	50	50	50	50	50	50	50	50	50
Area C (Borrow Pit)	926	3	69.2	69.7	73.1	76.7	77.7	86.3	61.8	62.3	65.7	61.5	61.7	63.7	13.6	13.6
<b>Total for Facilities</b>	<b>1119</b>	<b>130</b>	<b>196</b>	<b>197</b>	<b>200</b>	<b>208</b>	<b>209</b>	<b>217</b>	<b>189</b>	<b>189</b>	<b>193</b>	<b>189</b>	<b>189</b>	<b>191</b>	<b>200</b>	<b>207</b>

(a) To obtain areas in acres, multiply hectares (ha) by 2.47.  
 (b) Treatment and Storage Facility requirements would be the same for the following as for Alternative Group A (capping resource area same as for Alternative Group D<sub>1</sub>):  
 Alternative Group D<sub>1</sub>: Disposal in a lined modular facility near PUREX Plant  
 Alternative Group D<sub>2</sub>: Disposal in a lined modular facility in 200 East Area LLBGs  
 Alternative Group D<sub>3</sub>: Disposal in a lined modular facility at ERDF  
 Alternative Group E<sub>1</sub>: Disposal in lined modular facilities: LLW and MLLW in the 200 East Area LLBGs; ILAW and melters at ERDF  
 Alternative Group E<sub>2</sub>: Disposal in lined modular facilities: LLW and MLLW near PUREX; ILAW and melters at ERDF  
 Alternative Group E<sub>3</sub>: Disposal in lined modular facilities: LLW and MLLW at ERDF; ILAW and melters near PUREX  
 (c) Storage of waste in the CWC in the No Action Alternative would continue after 2046.  
 (d) NWPF = new waste processing facility.  
 (e) ETF = 200 Area Effluent Treatment Facility.  
 (f) LERF = Liquid Effluent Retention Facility.

## 5.2 Air Quality

Air quality impacts covered in this section focus on four criteria pollutants<sup>(a)</sup>—nitrogen dioxide (NO<sub>2</sub>), sulfur dioxide (SO<sub>2</sub>), carbon monoxide (CO), and particulate matter with aerodynamic diameters of 10 µm or smaller (PM<sub>10</sub>). Hanford Solid Waste (HSW) Program activities would emit criteria pollutants as a result of the operation of diesel-fired and propane-fueled equipment. Construction, earthmoving, and transportation activities also would result in fugitive dust emissions. Major program activities that would be substantial sources of criteria pollutants include:

- construction of waste-disposal trenches (for example, LLW, MLLW, ILAW)
- waste-disposal operations
- excavation of backfill and capping materials at the borrow pit
- transportation of backfill and capping materials from the borrow pit to the disposal trenches
- backfill and capping activities at the disposal trenches
- leachate drying operations.

The air quality impacts to the public from these and related program activities are presented in this section, and additional supporting information is provided in Volume II, Appendix E. The air quality impacts from criteria pollutants emitted during the transportation of waste materials are not included in this section, but are instead addressed in Section 5.8. The potential consequences to workers and the public of the releases from radiological and hazardous chemicals are addressed in Section 5.11.

In calculating air quality impacts for criteria pollutants, data on pollutant emissions were derived from the Hanford Solid Waste Technical Information Document (FH 2004). Detailed assessments of pollutant emissions were developed for each major program element. To compute maximum air quality impacts, emissions were combined from all activities that could potentially occur at the same time. Because only 22 percent of the LLW and essentially none of the MLLW would be from offsite sources, the air quality impacts for the Hanford Only waste volume under each alternative group were conservatively modeled as being equivalent to those for the Lower Bound waste volume under the same alternative group.

The approach used to estimate pollutant emission rates and emission schedules for all HSW Program activities are addressed in detail in Volume II, Appendix E.<sup>(b)</sup>

The maximum air quality impacts that would result from the emission of criteria pollutants from HSW Program activities were calculated using the Industrial Source Complex Short-Term (ISCST3)

---

(a) The Clean Air Act (42 USC 7401) authorizes the U.S. Environmental Protection Agency to set permissible levels of exposure for selected air pollutants using health-based criteria. These selected pollutants are called “criteria pollutants,” and their permissible exposure levels are defined in 40 CFR 50, “National Primary and Secondary Ambient Air Quality Standards.”

(b) Consequences of operating accelerated process lines would be similar to those from processing TRU waste at WRAP, although timing of the consequences may vary from assumptions based on operation of WRAP with APLs.

Dispersion Model (EPA 1995). The ISCST3 model has been approved by the U.S. Environmental Protection Agency (EPA) for the calculation of the maximum, time-averaged air concentrations at user-specified receptor locations. The model provides results for averaging periods of 1 hour, 3 hours, 8 hours, 24 hours, and 1 year to correspond to the time periods specified in national and state ambient air quality standards. Four years of hourly Hanford Site meteorological data were used in modeling atmospheric dispersion. The ISCST3 model and the data used in model runs are discussed in more detail in Volume II, Appendix E.

In modeling air quality impacts for the public, the following conservative assumptions were made to maximize impact estimates:

- Although HSW Program activities would occur at numerous locations in and around the 200 Areas and Area C, program activities were conservatively modeled by collocating their emissions into three small area sources. These area sources were situated in the 200 West Area (near the southwestern edge of project activities), 200 East Area (near the northwestern edge of project activities), and Area C (at a site close to State Route [SR] 240). The location of each area source was set to correspond to the project work site in the associated major operating area that could generate the greatest air quality impacts to the public.
- When a project activity could potentially occur at more than one source location, the activity was conservatively assumed to occur at the location that would generate the greatest air quality impact. For example, the lined modular facility proposed in Alternative Group D could be sited at locations in or near the 200 East or 200 West Areas, depending on the subalternative selected. After assessing impacts from both potential source locations, the 200 West Area source location was used in the air quality analysis because it generated the greatest air quality impacts.
- Even though the maximum air quality impacts to the public from the 200 East and 200 West source locations would occur at markedly different locations (as discussed later in this section), it was conservatively assumed that the maximum pollutant concentrations associated with these two source locations could be summed to compute total maximum air quality impacts for emissions from both 200 Area source locations.
- Chemical decay and deposition processes were not explicitly modeled for any criteria pollutant. Neglecting these removal mechanisms would increase estimates of maximum pollutant concentrations (especially in the case of particulate matter) at publicly accessible locations.
- Pollutant emission rates from diesel-fueled engines were only assumed to comply with current emissions standards. No credit was taken for the substantial reduction in the sulfur content of diesel fuel (from a 500-ppm to a 15-ppm limit) scheduled to be phased in beginning June 2006 or a tightening of the emission standards for nitrogen dioxide and particulate matter scheduled to be phased in beginning 2007 (EPA 2000b).

As a result of these and other conservative assumptions, the estimates of short-term and long-term maximum air quality impacts presented in this section should be substantially greater than what would actually be experienced during program implementation.

To meet regulatory requirements, emissions from program activities must not result in air concentrations of criteria pollutants that exceed regulatory limits. The ISCST3 model predicted the locations of the maximum air quality impacts to the public from emissions at the 200 East Area, 200 West Area, and Area C source locations. These are provided in Table 5.3 for the 200 East and 200 West Areas and in Table 5.4 for Area C. The location of maximum impact varies based on the averaging period of exposure. The maximum shorter-term air quality impacts (for example, 1 hour and 3 hours) generally occur at or near the closest point of public access. The locations of the longer-term maximum air quality impacts (for example, 24 hours and annual) are heavily dependent on local, prevailing wind directions and other meteorological conditions. Dispersion factors also are provided in Tables 5.3 and 5.4 to provide relative estimates of the maximum impacts from a unit release (for example, one unit of mass emitted per second) of a generic pollutant.

In the following sections, the results of the air quality analysis are presented for Alternative Groups A through E and the No Action Alternative. Separate results are provided for the maximum air quality impacts to the public from emissions in the 200 Areas and emissions in Area C.

**Table 5.3.** 200 East and 200 West Area Emissions: Location and Dispersion Factors Used to Determine Maximum Air Quality Impacts to the Public

Area	Averaging Time Period	Maximum Impact Location and Corresponding Public Access	Distance and Direction from Pollutant Release Location to Maximum Public Impact Location <sup>(a)</sup>	Dispersion Factor for Maximum Impact Location (s/m <sup>3</sup> ) <sup>(b)</sup>
200E	1 hr	SR 240	8.5 km–SW	8.4E-05
	3 hr	SR 240	9.0 km–SSW	3.3E-05
	8 hr	SR 240	9.0 km–SSW	2.2E-05
	24 hr	Hanford Site boundary	15.3 km–WNW	9.3E-06
	Annual	Hanford Site boundary	13.9 km–WNW	8.9E-08
200W	1 hr	SR 240	4.0 km–S	1.6E-04
	3 hr	SR 240	4.0 km–S	7.4E-05
	8 hr	SR 240	4.0 km–S	5.1E-05
	24 hr	Hanford Site boundary	8.5 km–WNW	1.6E-05
	Annual	Hanford Site boundary	11.5 km–W	1.5E-07

(a) Distance and direction determined by dispersion modeling. Pollutant transport direction is reported using 16 compass sectors—starting with N (North) and continuing clockwise with NNE, NE, ENE, E (East), ESE, SE, SSE, S (South), SSW, SW, WSW, W (West), WNW, NW, and NNW.

(b) Values computed by the ISCST3 model. To convert to a concentration estimate (µg/m<sup>3</sup>), a dispersion factor (s/m<sup>3</sup>) is multiplied by the estimated pollutant release rate (µg/s).

**Table 5.4.** Area C (Borrow Pit) Emissions: Location and Dispersion Factors Used to Determine Maximum Air Quality Impacts to the Public

<b>Averaging Time Period</b>	<b>Maximum Impact Location and Corresponding Public Access</b>	<b>Distance and Direction from Pollutant Release Location to Maximum Public Impact Location<sup>(a)</sup></b>	<b>Dispersion Factors for Maximum Impact Location (s/m<sup>3</sup>)<sup>(b)</sup></b>
1 hr	SR 240	<150 m NE	3.3E-03
3 hr	SR 240	<150 m NE	2.5E-03
8 hr	SR 240	<150 m NE	1.9E-03
24 hr	Hanford Site boundary	14.4 km WNW	1.0E-05
Annual	Hanford Site boundary	13.8 km WNW	9.2E-08

(a) Distance determined by dispersion modeling. Pollutant transport direction is reported using 16 compass sectors—starting with N (North) and continuing clockwise with NNE, NE, ENE, E (East), ESE, SE, SSE, S (South), SSW, SW, WSW, W (West), WNW, NW, and NNW.

(b) Values computed by the ISCST3 model. To convert to a concentration estimate ( $\mu\text{g}/\text{m}^3$ ), the dispersion factor ( $\text{s}/\text{m}^3$ ) is multiplied by the estimated pollutant release rate ( $\mu\text{g}/\text{s}$ ).

A Clean Air Act General Conformity Review analysis is presented in Volume II, Appendix E. Based on this analysis, it was concluded that a Conformity Determination would not be needed.

### 5.2.1 Alternative Group A

Project activities that would generate air quality impacts under Alternative Group A include the use of diesel-fueled equipment to construct new trenches of deeper and wider design than current trenches, construction of the ILAW and melter trenches, backfilling of trenches, capping the LLBGs and the ILAW trench at closure, performing routine CWC and T Plant operations, modifying the T Plant to achieve a waste processing capability, and the excavation and transportation of materials from the borrow pit. In addition, propane-fueled pulse driers would be used to treat leachate from the MLLW trenches beginning in 2026. Fugitive dust emissions would be associated with many major construction and operation activities.

For Alternative Group A (Hanford Only and Lower Bound waste volumes), the largest air quality impacts would occur during two different periods of project operation. In 2006, ILAW trench construction and MLLW capping and backfill operations would be underway. The heavy use of construction equipment for short periods of time would produce the maximum 24-hour and shorter-term average concentrations for SO<sub>2</sub> and CO. After disposal operations cease, LLBG and ILAW capping operations would be in full swing. This sustained activity would produce the maximum 24-hour and annual concentrations of PM<sub>10</sub> and maximum annual concentrations of NO<sub>2</sub> and SO<sub>2</sub>.

For Alternative Group A (Upper Bound waste volume), the largest air quality impacts would occur during three different periods of project operation. In 2006, the heavy use of construction equipment would produce the maximum concentrations over all averaging periods for CO, SO<sub>2</sub>, and NO<sub>2</sub>. In 2018, LLW and ILAW trench construction, coupled with MLLW melter capping and backfilling operations,

would generate the maximum 24-hour PM<sub>10</sub> concentrations. After disposal operations cease, LLBG and ILAW capping operations would be in full swing. This sustained activity would produce the maximum annual concentrations of PM<sub>10</sub>.

Estimates of the maximum air quality impacts to the public from activities in the 200 Areas under Alternative Group A are summarized in Table 5.5. Estimates of the maximum air quality impacts from Area C activities are presented in Table 5.6. The maximum air quality impacts from Area C activities are the same for all alternative groups. The impacts from the single activity undertaken in Area C are less than the maximum impacts from the multiple activities undertaken in Alternative Group A.

Even in the years with the largest potential air quality impacts, ambient air quality standards (see Table 4.6, Section 4.3.3) would not be exceeded under Alternative Group A. The largest potential impacts to the public from activities at Area C would result from SO<sub>2</sub> and CO emissions. Maximum air

**Table 5.5.** Alternative Group A: Maximum Air Quality Impacts to the Public from Activities in the 200 Areas

Pollutant	Averaging Time	Ambient Air Quality Standard (µg/m <sup>3</sup> )	Hanford Only & Lower Bound Waste Volumes		Upper Bound Waste Volume	
			Maximum Air Quality Impacts (µg/m <sup>3</sup> )	Percent of Standard	Maximum Air Quality Impacts (µg/m <sup>3</sup> )	Percent of Standard
PM <sub>10</sub>	24 hr	150	69	46	74	49
	Annual	50	0.61	1.2	0.62	1.2
SO <sub>2</sub>	1 hr	1,000	81	8.1	98	9.8
	3 hr	1,300	38	2.9	45	3.5
	24 hr	260	2.7	1.0	3.5	1.3
	Annual	50	0.017	0.034	0.019	0.038
CO	1 hr	40,000	1,500	3.8	900	4.6
	8 hr	10,000	470	4.7	590	5.9
NO <sub>2</sub>	Annual	100	0.72	0.72	0.80	0.80

**Table 5.6.** All Alternative Groups: Maximum Air Quality Impacts to the Public from Area C (Borrow Pit) Activities

Pollutant	Averaging Time	Ambient Air Quality Standard (µg/m <sup>3</sup> )	Maximum Air Quality Impacts	
			Maximum Pollutant Concentration (µg/m <sup>3</sup> )	Percent of Standard
PM <sub>10</sub>	24 hr	150	21	14
	Annual	50	0.19	0.38
SO <sub>2</sub>	1 hr	1,000	260	26
	3 hr	1,300	200	15
	24 hr	260	0.44	0.17
	Annual	50	0.0035	0.0070
CO	1 hr	40,000	6,300	16
	8 hr	10,000	3,600	36
NO <sub>2</sub>	Annual	100	0.16	0.16



quality impacts to the public are conservatively estimated to be about 26 percent of the 1-hour SO<sub>2</sub> standard and 36 percent of the 8-hour CO standard. The largest potential impacts to the public from activities within the 200 Areas would involve the 24-hour PM<sub>10</sub> standard. Using the series of conservative assumptions employed in the air-dispersion modeling, this maximum air quality impact would be about half of the 24-hour PM<sub>10</sub> standard.

### **5.2.2 Alternative Group B**

Project activities that would generate air quality impacts under Alternative Group B include the use of diesel-fueled equipment to construct additional trenches of current design and the ILAW and melter trenches, backfilling and capping activities in the LLBGs, construction of a new waste processing facility, and the excavation of materials at the borrow pit. In addition, propane would be used to fuel vehicles at the CWC and to operate pulse driers used to treat leachate from the MLLW trenches. Fugitive dust would be associated with all major construction and operation activities.

For Alternative Group B (Hanford Only and Lower Bound waste volumes), the largest air quality impacts would occur during two different periods of project operation. In 2011, ILAW trench construction, LLW trench construction, and MLLW capping and backfill operations would be underway. The heavy use of construction equipment for short periods of time would produce the maximum pollutant concentrations for CO, SO<sub>2</sub>, and NO<sub>2</sub>. After disposal operations cease, LLBG and ILAW capping operations would be in full swing. This sustained activity would produce maximum 24-hour and annual concentrations of PM<sub>10</sub> that would be slightly greater than in 2011.

For Alternative Group B (Upper Bound waste volume), the largest air quality impacts would occur during three different periods of project operation. In 2006, the heavy use of construction equipment would produce the maximum pollutant concentrations over the relevant 1-hour, 3-hours, 8-hours, and 24-hour averaging periods for CO and SO<sub>2</sub>. In 2011, LLW and ILAW trench construction, coupled with MLLW melter capping and backfilling operations, would generate the maximum annual SO<sub>2</sub> and NO<sub>2</sub> concentrations. After disposal operations cease, LLBG and ILAW capping operations would be in full swing. This sustained activity would produce the maximum 24-hour and annual concentrations of PM<sub>10</sub>.

Estimates of the maximum air quality impacts to the public from activities in the 200 Areas under Alternative Group B are summarized in Table 5.7. Estimates of the maximum air quality impacts from Area C activities are the same for all alternative groups (see Table 5.6).

All air quality impacts to the public under Alternative Group B would be within ambient air quality standards (see Table 4.6, Section 4.3.3). The largest potential impact to the public from activities at Area C would result from SO<sub>2</sub> and CO emissions. The largest potential air quality impacts to the public from 200 Area emissions would involve the 24-hour PM<sub>10</sub> air concentration. Even using the series of conservative assumptions employed in the dispersion modeling, the maximum air quality impact to the public for the Upper Bound waste volume would be about 60 percent of the applicable air quality standard. Maximum impacts for the Hanford Only and Lower Bound waste volumes would be less than 47 percent of the applicable standards.

**Table 5.7.** Alternative Group B: Maximum Air Quality Impacts to the Public from Activities in the 200 Areas

Pollutant	Averaging Time	Ambient Air Quality Standard ( $\mu\text{g}/\text{m}^3$ )	Hanford Only & Lower Bound Waste Volumes		Upper Bound Waste Volume	
			Maximum Air Quality Impacts ( $\mu\text{g}/\text{m}^3$ )	Percent of Standard	Maximum Air Quality Impacts ( $\mu\text{g}/\text{m}^3$ )	Percent of Standard
PM <sub>10</sub>	24 hr	150	71	47	90	60
	Annual	50	0.62	1.2	0.65	1.3
SO <sub>2</sub>	1 hr	1,000	130	13	180	18
	3 hr	1,300	61	4.7	85	6.5
	24 hr	260	4.7	1.8	6.4	2.5
	Annual	50	0.021	0.042	0.021	0.042
CO	1 hr	40,000	2,500	6.3	3,400	8.5
	8 hr	10,000	800	8.0	1,100	11
NO <sub>2</sub>	Annual	100	1.0	1.0	1.1	1.1

### 5.2.3 Alternative Group C

Project activities that would generate air quality impacts under Alternative Group C include the use of diesel-fueled equipment to construct new expandable trenches for LLW and for MLLW, construction of the ILAW and melter trenches, backfilling of trenches, capping the LLBGs and the ILAW trench at closure, performing routine CWC and T Plant operations, modifying the T Plant for a new waste processing capability, and the excavation and transportation of materials from the borrow pit. In addition, propane engines would be used at the CWC and to operate pulse driers used to treat leachate from the MLLW trenches. Fugitive dust would be associated with all major construction and operation activities.

For Alternative Group C (Hanford Only and Lower Bound waste volumes), the largest air quality impacts would occur during three different periods of project operation. In 2007, the heavy use of construction equipment would produce the maximum pollutant concentrations over 1-hour and 3-hour averaging periods for SO<sub>2</sub>. In 2018, ILAW trench construction and MLLW capping and backfill operations would be under way. This use of construction equipment for long periods of time would produce the maximum 24-hour and annual concentrations for SO<sub>2</sub>, the maximum 1-hour and 8-hour pollutant concentrations for CO, and the maximum annual concentration of NO<sub>2</sub>. After disposal operations cease, LLBG and ILAW capping operations would be in full swing. This sustained activity would produce the maximum 24-hour and annual concentrations of PM<sub>10</sub>.

For Alternative Group C (Upper Bound waste volume), the largest air quality impacts would occur during four different periods of project operation. In 2007, the construction of ILAW, LLW, and MLLW trenches would produce the maximum concentrations over 1-hour and 3-hour averaging periods for SO<sub>2</sub> and an 8-hour averaging period for CO. In 2018, ILAW trench construction, coupled with MLLW melter capping and backfilling operations, would generate the maximum 24-hour and annual concentrations of

SO<sub>2</sub>, annual concentrations of NO<sub>2</sub>, and 1-hour concentrations of CO. After disposal operations cease, LLBG and ILAW capping operations would be in full swing. This sustained activity would produce the maximum 24-hour and annual concentrations of PM<sub>10</sub>.

Estimates of the maximum air quality impacts to the public from activities in the 200 Areas under Alternative Group C are summarized in Table 5.8. Estimates of the maximum air quality impacts from Area C activities are the same for all alternative groups (see Table 5.6).

All air quality impacts to the public from Alternative Group C would be within ambient air quality standards (see Table 4.6, Section 4.3.3). The largest potential impacts to the public from activities at Area C would result from SO<sub>2</sub> and CO emissions. The largest potential air quality impacts to the public from activities in the 200 Areas would involve the 24-hour PM<sub>10</sub> concentration. Even using the series of conservative assumptions employed in the dispersion modeling, this maximum air quality impact would be about 40 percent of the applicable air quality standard.

#### 5.2.4 Alternative Groups D<sub>1</sub>, D<sub>2</sub>, and D<sub>3</sub>

Project activities that would generate air quality impacts under Alternative Groups D<sub>1</sub>, D<sub>2</sub>, and D<sub>3</sub> (collectively referred to in this section as Alternative Group D) include the use of diesel-fueled equipment to construct a lined modular facility to hold the LLW, MLLW, ILAW and melters, backfilling and capping activities in the LLBGs, the modification of T Plant, and the excavation of materials at the borrow pit. In addition, propane would be used at the CWC and to operate pulse driers used to treat leachate from the MLLW trenches. Fugitive dust would be associated with all major construction and operation activities. Alternative Groups D<sub>1</sub>, D<sub>2</sub>, and D<sub>3</sub> postulate different locations for the lined modular

**Table 5.8.** Alternative Group C: Maximum Air Quality Impacts to the Public from Activities in the 200 Areas

Pollutant	Averaging Time	Ambient Air Quality Standard (µg/m <sup>3</sup> )	Hanford Only & Lower Bound Waste Volumes		Upper Bound Waste Volume	
			Maximum Air Quality Impacts (µg/m <sup>3</sup> )	Percent of Standard	Maximum Air Quality Impacts (µg/m <sup>3</sup> )	Percent of Standard
PM <sub>10</sub>	24 hr	150	60	40	61	41
	Annual	50	0.53	1.1	0.54	1.1
SO <sub>2</sub>	1 hr	1,000	79	7.9	80	8.0
	3 hr	1,300	36	2.8	37	2.8
	24 hr	260	2.9	1.1	2.9	1.1
	Annual	50	0.018	0.036	0.018	0.036
CO	1 hr	40,000	1,500	3.8	1,500	3.8
	8 hr	10,000	460	4.6	470	4.7
NO <sub>2</sub>	Annual	100	0.77	0.77	0.77	0.77

facility. In conducting air quality modeling, a conservative 200 West Area source location was assumed in all cases for the lined modular facility. As a result, the air quality estimates for Alternative Groups D<sub>1</sub>, D<sub>2</sub>, and D<sub>3</sub> are equivalent.

For Alternative Group D (Hanford Only, Lower Bound, and Upper Bound waste volumes), the largest air quality impacts would occur during two different periods of project operation. In 2006, the lined modular facility construction and capping of an existing MLLW trench would be under way. The heavy use of construction equipment for short periods of time would produce the maximum average pollutant concentrations for CO, SO<sub>2</sub>, and NO<sub>2</sub>. After disposal operations cease, the lined modular facility capping operations would be in full swing. This sustained activity would produce the maximum 24-hour and annual concentrations of PM<sub>10</sub>.

Estimates of the maximum air quality impacts to the public from activities in the 200 Areas under Alternative Group D are summarized in Table 5.9. Estimates of the maximum air quality impacts from Area C activities are the same for all alternative groups (see Table 5.6).

All air quality impacts from Alternative Group D would be within ambient air quality standards. The largest potential impacts to the public from Area C activities would result from SO<sub>2</sub> and CO emissions. The largest potential air quality impacts to the public from activities in the 200 Areas would involve the 24-hour PM<sub>10</sub> air concentration. Using the series of conservative assumptions employed in the dispersion modeling, this maximum air quality impact would be about 41 percent of the applicable air quality standard.

**Table 5.9.** Alternative Group D: Maximum Air Quality Impacts to the Public from Activities in the 200 Areas

Pollutant	Averaging Time	Ambient Air Quality Standard (µg/m <sup>3</sup> )	Hanford Only & Lower Bound Waste Volumes		Upper Bound Waste Volume	
			Maximum Air Quality Impacts (µg/m <sup>3</sup> )	Percent of Standard	Maximum Air Quality Impacts (µg/m <sup>3</sup> )	Percent of Standard
PM <sub>10</sub>	24 hr	150	61	41	62	41
	Annual	50	0.53	1.1	0.54	1.1
SO <sub>2</sub>	1 hr	1,000	84	8.4	84	8.4
	3 hr	1,300	38	2.9	38	2.9
	24 hr	260	3.1	1.2	3.1	1.2
	Annual	50	0.019	0.038	0.019	0.038
CO	1 hr	40,000	1,590	4.0	1,590	4.0
	8 hr	10,000	500	5.0	500	5.0
NO <sub>2</sub>	Annual	100	0.79	0.79	0.85	0.85

### 5.2.5 Alternative Groups E<sub>1</sub>, E<sub>2</sub>, and E<sub>3</sub>

Project activities that would generate air quality impacts under Alternative Groups E<sub>1</sub>, E<sub>2</sub>, and E<sub>3</sub> (collectively referred to in this section as Alternative Group E) include the use of diesel-fueled equipment to construct a lined modular facility for LLW and MLLW, construction of the ILAW and melter trenches, backfilling and capping activities in the LLBGs, modification of T Plant, and the excavation of materials at the borrow pit. In addition, propane engines would be used at the CWC and to operate pulse driers used to treat leachate from the MLLW trenches. Fugitive dust would be associated with all major construction and operation activities. Alternative Groups E<sub>1</sub>, E<sub>2</sub>, and E<sub>3</sub> postulate different locations for the lined modular facility. In conducting air quality modeling, a conservative 200 West Area source location was assumed in all cases for the lined modular facility. As a result, the air quality estimates for Alternative Groups E<sub>1</sub>, E<sub>2</sub>, and E<sub>3</sub> are equivalent.

For Alternative Group E (Hanford Only, Lower Bound, and Upper Bound waste volumes), the largest air quality impacts would occur during three different periods of project operation. In 2006, the heavy use of construction equipment for concurrent construction of LLW, MLLW, and ILAW trenches and the capping of an existing MLLW trench would produce the maximum 24-hour and annual concentrations of SO<sub>2</sub>. In 2007, trench construction activities would be underway, which would produce the maximum 1- and 8-hour concentrations of CO, the maximum 1- and 3-hour concentrations of SO<sub>2</sub>, and the maximum annual NO<sub>2</sub> concentrations. After disposal operations cease, LLBG and ILAW capping operations would be in full swing. This sustained activity would produce the maximum 24-hour and annual concentrations of PM<sub>10</sub>.

Estimates of the maximum air quality impacts to the public from activities in the 200 Areas under Alternative Group E are summarized in Table 5.10. Estimates of the maximum air quality impacts to the public from Area C activities are the same for all alternative groups (see Table 5.6).

All air quality impacts from Alternative Group E would be within ambient air quality standards (see Table 4.6, Section 4.3.3). The largest potential impacts to the public from activities at Area C would result from SO<sub>2</sub> and CO emissions. The largest potential air quality impact to the public from activities in the 200 Areas would involve the 24-hour PM<sub>10</sub> air concentration. Using the series of conservative assumptions employed in the dispersion modeling, this maximum air quality impact would be about 41 percent of the applicable air quality standard.

### 5.2.6 No Action Alternative

Project activities that would generate air quality impacts under the No Action Alternative include the use of diesel-fueled equipment during construction of additional trenches of current design, construction of the ILAW trench and 66 CWC buildings, backfilling the LLW and MLLW trenches, capping two existing MLLW trenches, and excavation of materials at the borrow pits. A propane-fueled pulse drier would be used to treat MLLW trench leachate, beginning in 2026. Fugitive dust would be associated with all major construction and operation activities.

**Table 5.10.** Alternative Group E: Maximum Air Quality Impacts to the Public from Activities in the 200 Areas

Pollutant	Averaging Time	Ambient Air Quality Standard ( $\mu\text{g}/\text{m}^3$ )	Hanford Only & Lower Bound Waste Volumes		Upper Bound Waste Volume	
			Maximum Air Quality Impacts ( $\mu\text{g}/\text{m}^3$ )	Percent of Standard	Maximum Air Quality Impacts ( $\mu\text{g}/\text{m}^3$ )	Percent of Standard
PM <sub>10</sub>	24 hr	150	60	40	62	41
	Annual	50	0.53	1.1	0.54	1.1
SO <sub>2</sub>	1 hr	1,000	93	9.3	95	9.5
	3 hr	1,300	42	3.2	42	3.2
	24 hr	260	3.1	1.2	3.2	1.2
	Annual	50	0.019	0.038	0.020	0.040
CO	1 hr	40,000	1,700	4.3	1,700	4.3
	8 hr	10,000	530	5.3	530	5.3
NO <sub>2</sub>	Annual	100	0.89	0.89	0.89	0.89

For the No Action Alternative (Hanford Only and Lower Bound waste volumes), the largest air quality impacts would occur during two different periods of project operation. In 2007, the heavy use of construction equipment to construct LLW trenches and CWC buildings, the capping of existing MLLW trenches, and propane use at CWC would produce the maximum 24-hour and annual concentrations of PM<sub>10</sub>. In 2034, ILAW vault and final LLW trench construction would be underway, and propane for CWC and pulse drier operations would be at their peak. These activities would produce the maximum concentrations of SO<sub>2</sub> over all averaging periods, the maximum annual concentrations of NO<sub>2</sub>, and the maximum 1- and 8-hour concentrations of CO.

Estimates of the maximum air quality impacts to the public from activities in the 200 Areas under the No Action Alternative are presented in Table 5.11. Estimates of the maximum air quality impacts to the public from Area C activities are the same for all alternative groups (see Table 5.6).

All air quality impacts from the No Action Alternative would be within ambient air quality standards (see Table 4.6, Section 4.3.3). The largest potential impacts to the public from Area C activities would result from SO<sub>2</sub> and CO emissions. The largest potential air quality impact from emissions in the 200 Areas would involve the 24-hour PM<sub>10</sub> air concentration. Using the series of conservative assumptions employed in the dispersion modeling, this maximum air quality impact would be about 38 percent of the applicable air quality standard.

**Table 5.11.** No Action Alternative: Maximum Air Quality Impacts to the Public from Activities in the 200 Areas

Pollutant	Averaging Time	Ambient Air Quality Standard ( $\mu\text{g}/\text{m}^3$ )	Maximum Air Quality Impacts	
			Maximum Pollutant Concentration ( $\mu\text{g}/\text{m}^3$ )	Percent of Standard
PM <sub>10</sub>	24 hr	150	57	38
	Annual	50	0.37	0.74
SO <sub>2</sub>	1 hr	1,000	86	8.6
	3 hr	1,300	35	2.7
	24 hr	260	3.4	1.3
	Annual	50	0.019	0.038
CO	1 hr	40,000	1,600	4.0
	8 hr	10,000	460	4.6
NO <sub>2</sub>	Annual	100	0.85	0.85

### 5.2.7 Comparison of the Alternative Groups

Table 5.12 presents a summary comparison across all alternative groups of maximum ambient air quality impacts to the public from activities in the 200 Areas. The greatest air quality impacts are experienced under Alternative Group B–Upper Bound waste volume. Depending on the pollutant and averaging period, the lowest air quality impacts are experienced under Alternative Group A–Hanford Only and Lower Bound waste volumes, Alternative Group C–Hanford Only and Lower Bound waste volumes, Alternative Group C–Upper Bound waste volume, and the No Action Alternative.

The only air quality impacts to the public from activities in the 200 Areas that would exceed 10 percent of their applicable ambient air quality standards would be the maximum 24-hour concentration of PM<sub>10</sub>, 1-hour concentration of SO<sub>2</sub>, and 8-hour concentration of CO. Only the maximum 24-hour concentration of PM<sub>10</sub> under Alternative Group B–Upper Bound waste volume would exceed 50 percent of the applicable air quality standard. For activities in Area C, the maximum 1- and 8-hour concentrations of CO, 1- and 3-hour concentrations of SO<sub>2</sub>, and 24-hour concentration of PM<sub>10</sub> would be greater than 10 percent of the applicable ambient air quality standards (see Table 5.6). None of these impacts would exceed 50 percent of the applicable air quality standard.

It should be re-emphasized that the air quality impacts presented above are all based on a series of conservative assumptions. In particular, the incorporation of particulate deposition processes in the air quality modeling or the consideration of more stringent vehicle pollutant emission standards that are currently scheduled for future implementation would substantially reduce estimates of many maximum air quality impacts.

It is important to note that the maximum short-term air quality impacts to the public from activities in the 200 East and 200 West Areas and Area C should not be summed to come up with a combined air quality impact. For averaging periods of 24 hours and less, the maximum air quality impacts to the public from emissions in the 200 Areas and Area C would occur under markedly different flow regimes and

would therefore occur at different times and have different impact locations. As a result, the maximum short-term air quality impacts to the public from emissions at one source location would not be appreciably impacted by emissions from the other source location. For annual air quality impacts to the public, it is extremely conservative to sum maximum annual impacts from different source locations to estimate the maximum cumulative impact. For the HSW Program, the combined maximum annual air quality impacts from emissions in each source location would be very small (that is, less than 2 percent of any annual air quality standard).



**Table 5.12.** Comparison Across all Alternative Groups of Maximum Air Quality Impacts to the Public from Activities in the 200 Areas

		Maximum Air Quality Impacts in Terms of Percent of the Associated Ambient Air Quality Standard										
		Alternative Group A		Alternative Group B		Alternative Group C		Alternative Group D		Alternative Group E		No Action
Pollutant	Averaging Time	Hanford & Lower Bound Waste Volumes	Upper Bound Waste Volume	Hanford & Lower Bound Waste Volumes	Upper Bound Waste Volume	Hanford & Lower Bound Waste Volumes	Upper Bound Waste Volume	Hanford & Lower Bound Waste Volumes	Upper Bound Waste Volume	Hanford & Lower Bound Waste Volumes	Upper Bound Waste Volume	Hanford & Lower Bound Waste Volumes
PM <sub>10</sub>	24 hr	46	49	47	60	40	41	41	41	40	41	38
	Annual	1.2	1.2	1.2	1.3	1.1	1.1	1.1	1.1	1.1	1.1	0.74
SO <sub>2</sub>	1 hr	8.1	9.8	13	18	7.9	8.0	8.4	8.4	9.3	9.5	8.6
	3 hr	2.9	3.5	4.7	6.5	2.8	2.8	2.9	2.9	3.2	3.2	2.7
	24 hr	1.0	1.3	1.8	2.5	1.1	1.1	1.2	1.2	1.2	1.2	1.3
	Annual	0.034	0.038	0.042	0.042	0.036	0.036	0.038	0.038	0.038	0.040	0.038
CO	1 hr	3.8	4.6	6.3	8.5	3.8	3.8	4.0	4.0	4.3	4.3	4.0
	8 hr	4.8	5.9	8.0	11	4.6	4.7	5.0	5.0	5.3	5.3	4.6
NO <sub>2</sub>	Annual	0.72	0.80	1.0	1.1	0.77	0.77	0.79	0.85	0.89	0.89	0.85

## 5.3 Water Quality

This section discusses potential short-term impacts on groundwater quality from operations and construction of Hanford solid waste (HSW) disposal sites and related facilities and potential long-term impacts on groundwater and the Columbia River from contaminant releases from HSW disposal facilities after site closure in 2046 based on conservative assumptions used in this HSW EIS. Potential short-term impacts during the period of operations and construction are discussed in Section 5.3.1. An overview of assessment methods used to determine the potential long-term impacts to groundwater and the Columbia River are presented in Section 5.3.2. Detailed information on the long-term assessment methods and results are provided in Volume II, Appendix G. Section 5.3.3 discusses the use of immobilized low-activity waste (ILAW) performance assessment calculations to support this EIS. Details from the water quality analysis presented in Section 5.3.4 and in Volume II, Appendix G are used in the preparation of estimates of potential impacts on public health and safety, as provided in Section 5.11.

As a result of wastewater management activities during past Hanford Site operations, groundwater beneath the 200 Areas has been contaminated with radionuclides and non-radioactive chemicals. The contaminants emanating from the 200 Areas are moving toward the Columbia River. Radioactive contaminants present in groundwater beneath the 200 Areas that exceed values cited in Table 4.10 (see Section 4.5.3) are tritium, strontium-90, technetium-99, iodine-129, plutonium, cesium-137, total alpha, total beta, and uranium. Hazardous chemical contaminants present at levels exceeding values in Table 4.10 include nitrate, fluoride, chromium, carbon tetrachloride, trichloroethene, cyanide, tetrachloroethene, and cis-1, 2-dichloroethene. None of these contaminants is thought to have originated from the LLBGs being considered in this EIS (Hartman et al. 2002).

### 5.3.1 Potential Short-Term Impacts of Operations and Construction Activities

In the HSW management facilities, water is derived from the Hanford Site Export Water System is used for dust suppression during operations and construction. The Hanford Site Export Water System extracts potable water for fire suppression and industrial use in the Central Plateau from the Columbia River intake locations in the 100 D Area. Water from the export system also is expected to be used at existing sanitary facilities and would be disposed of after treatment. Because most of these operational water discharges would occur in uncontaminated areas, the discharges would not be expected to have a substantial effect on the groundwater system from leaching or the driving force of the wastes. Potential groundwater quality impacts would not be expected. In the case of capping the HSW disposal facilities at closure where water is used for short-term dust suppression, the 25-cm (10-in) layer of asphalt at the base of the cap is expected to divert water away from the waste and is not expected to result in impacts to groundwater quality. Use of process water is not anticipated for any of the HSW management facilities and is not considered further in terms of water quality.

Solid LLW disposed of after 1988 in the HSW disposal facilities is largely dry solid waste with limited amounts of free liquid that could otherwise result in waste leaching and release through the vadose zone and into the groundwater. Since that time, LLW has been categorized into Category (Cat) 1 and Cat 3 LLW based on stringent waste acceptance criteria for radionuclide inventory content. Further, beginning in 1995, systematic use of waste containment and containers, such as emplacing all wastes in

steel boxes, drums, high-integrity containers (HIC), and grouted waste forms, was implemented to minimize leaching and release of contaminants during the period of operations. In addition, MLLW is being disposed of in RCRA-compliant trenches with a liner system to facilitate monitoring, management, and treatment of leachate during operations (see Section 3.1).

Because waste containment using containers described above was not systemically used prior to 1995, contaminants contained in solid LLW disposed of in LLBGs prior to 1995 offer the highest potential for leaching and release into the vadose zone prior to site closure. The analysis conducted for this HSW EIS conservatively evaluated the potential impacts of these earlier disposals by evaluating the effect of higher infiltration rates during operations. Results of analyses of earlier disposal facilities used release and vadose zone infiltration rates of 5 cm/yr, a rate reflective of managed bare surface soil conditions over the older disposal areas during the operations phase. Mobile contaminants (such as technetium-99 and iodine-129) disposed of before 1995 were estimated to arrive several hundred years before mobile contaminants disposed of after 1995. Peak concentrations of technetium-99 and iodine-129 were estimated to arrive at downgradient locations between years 2050 and 2100 from 200 East Area locations and year 2150 and 2200 from 200 West Area locations. Descriptions of the underlying assumptions and resulting estimated impacts (that is, contaminant concentration levels and peak arrival times) from these analyses are provided in detail in Volume II, Appendix G.

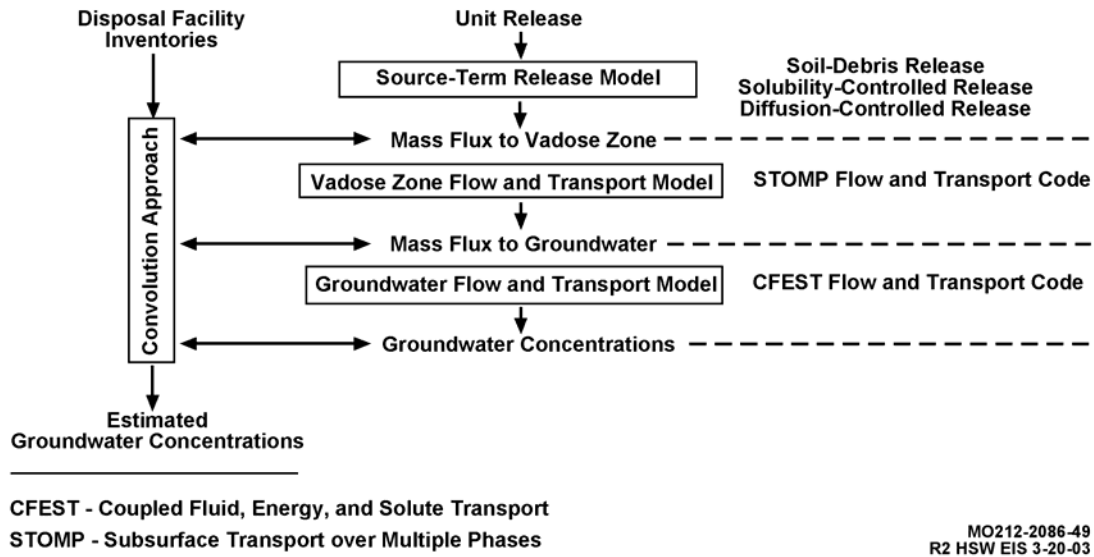
### **5.3.2 Methods for Assessment of Potential Long-Term Impacts**

The groundwater exposure pathway considers the long-term release of contaminants from a variety of LLW and MLLW downward through the vadose zone underlying the HSW disposal facilities and laterally through the unconfined aquifer immediately underlying the vadose zone to the Columbia River. The LLBG are all located in the 200 Areas, and the physical area of potential groundwater impact is the unconfined aquifer bounded laterally by the Rattlesnake Hills to the west and southwest, by the Columbia River to the north and east, and by the Yakima River to the south (see Section 4.5.3, Figure 4.17).

The sequence of calculations used in the long-term assessment required using a suite of process models that estimated source-term release, vadose zone flow and transport, and groundwater flow and transport. The computational framework for these process models and relationship of software elements is schematically illustrated in Figure 5.1.

Wastes considered in this assessment include previously disposed of wastes and wastes to be disposed of in the HSW disposal facilities (for purposes of analysis, year 2007 was assumed to be the date when new disposal facilities would be operational):

- Previously disposed of LLW, which includes:
  - LLW disposed of in LLBGs between 1962 and 1970 (referred to as pre-1970 LLW in this section).
  - LLW disposed of in LLBGs after 1970, but before October 1987 (referred to as 1970–1987 LLW in this section).



**Figure 5.1.** Schematic Representation of Computational Framework and Codes Used in the HSW EIS

- LLW disposed of in LLBGs after October 1987, but before 1995 (referred to as 1988–1995 LLW in this section).
- Cat 1 LLW, which includes:
  - Cat 1 LLW disposed of in the LLBGs after 1995 including Cat 1 LLW forecasted to be disposed of through 2007 (referred to as Cat 1 LLW [1996–2007] in this section).
  - Cat 1 LLW disposed of after 2007 including Cat 1 LLW forecasted to be disposed of through 2046 (referred to as Cat 1 LLW disposed of after 2007 in this section). For purposes of analysis, year 2007 was assumed to be the date when new disposal facilities would be operational.
- Cat 3 LLW, which includes:
  - Cat 3 and greater than Cat 3 (GTC3) LLW disposed of in the LLBGs after 1995 including Cat 3 LLW forecasted to be disposed of through 2007 (referred to as Cat 3 LLW [1996–2007] in this section).
  - Cat 3 and GTC3 LLW disposed of after 2007 including Cat 3 LLW forecasted to be disposed of through 2046 (referred to as Cat 3 LLW disposed of after 2007 in this section).
- MLLW, which includes:
  - MLLW disposed of after 1996 including MLLW forecasted to be disposed of through 2007 (referred to as MLLW [1996–2007] in this section). MLLW received since 1988 has been in storage awaiting final treatment.

- MLLW disposed of after 2007 including MLLW forecasted to be disposed of through 2046 (referred to as MLLW disposed of after 2007 in this section).
- Melters from the tank waste treatment program.
- ILAW from the tank waste treatment program.

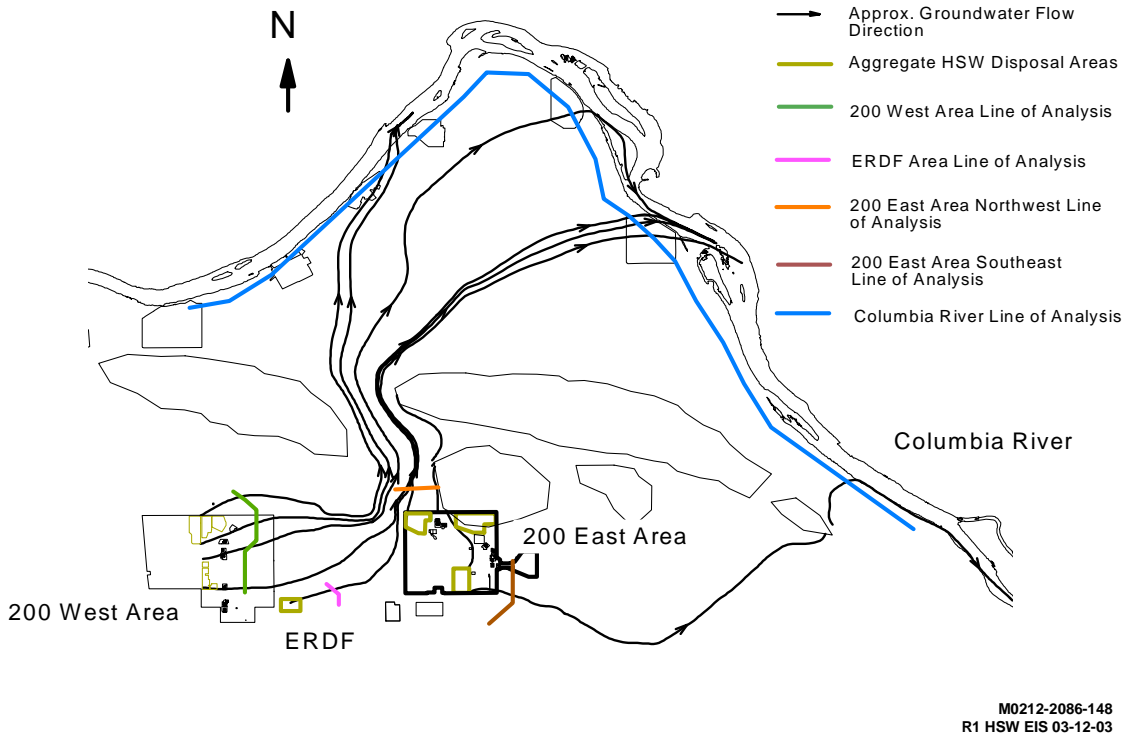
Inventories of retrievably stored transuranic (TRU) waste in trenches and caissons located in the LLBGs were not evaluated for their potential groundwater quality impacts because the TRU waste will be retrieved and sent to the Waste Isolation Pilot Plant for disposal. TRU waste is stored in containers, and the configuration in which the TRU waste containers are stored (including coverings to prevent intrusion of water and asphalt storage pads) provides additional protection from releases. Procedures require that waste container integrity and containment inspections be performed during the retrieval. Any releases would be characterized and addressed consistent with existing procedures and plans.

Although not specifically required by current DOE standards for LLW management, this assessment examined potential groundwater quality impacts for up to 10,000 years after the operational period. Current requirements under the guidelines for a performance assessment of LLW disposal facilities, as prescribed in (DOE 2001b), focus on potential impacts during the first 1,000 years after disposal.

This groundwater assessment was performed using a combination of screening techniques and numerical modeling. The groundwater modeling results estimate contaminant concentrations in the groundwater associated with selected alternatives evaluated in this HSW EIS from the end of waste operations in 2046 up to 10,000 years from 2046. This analysis also evaluates potential early waste release and contaminant transport from wastes disposed of before 1996, including pre-1970 LLW, 1970-1987 LLW, and 1988-1995 LLW, and examines the potential for release and vadose zone transport during the operational period.

The lines of analysis (LOAs) used in this comparative assessment were located on the Hanford Site along lines approximately 1 km (0.6 mi) downgradient from the 200 East and West Areas, at ERDF, and near the Columbia River, as shown in Figure 5.2. Additional analyses of potential groundwater quality impacts for a new combined-use facility (as presented for Alternative Groups D<sub>1</sub>, D<sub>2</sub>, and D<sub>3</sub>), are presented in Section 5.3.6 and in Volume II, Appendix G, Section G.5, and provide a perspective on the relative impact at waste management boundaries immediately downgradient of the aggregate waste disposal area versus potential impacts at the 1-km LOAs. A similar impact analysis is provided for LLW and MLLW disposed of before 2007 for another perspective.

All locations were selected based on simulated transport results of unit releases at selected HSW disposal facilities. These LOAs in each area are not meant to represent points of regulatory compliance, but rather common locations to facilitate a comparison of the waste management activities and locations defined for each alternative group. Constituent concentrations presented for each alternative group from specific waste category releases represent maximum concentrations estimated along these LOAs. Because of the variation in the location of the different waste types and category releases for a given alternative group, the estimated maximum concentrations calculated from a specific waste category release may not correspond to the same point on the line of analysis for every waste category and



**Figure 5.2.** LOAs Used in Comparing Potential Long-Term Groundwater Quality Impacts

alternative group. Combined concentration levels presented for each LOA and alternative group reflect the summation of estimated concentration levels regardless of their position on the LOA. As a consequence, the actual maximum concentrations at a given point along the LOA would be overestimated when combining concentration levels.

Delineation of potential waste impacts in the 200 East Area required two different LOAs. One LOA, designated as the 200 East Northwest (NW) LOA, is used to evaluate concentrations in groundwater migrating northwest from the 200 East Area. Another LOA, designated as the 200 East Southeast (SE) LOA, is used to evaluate concentrations in groundwater migrating southeast from the 200 East Area.

The HSW disposal facilities contain over 100 radioactive and non-radioactive waste constituents. Potential impacts to groundwater within the 10,000-year period of analysis were based primarily on the overall mobility of the constituents. To establish their relative mobility, the constituents were grouped based on their mobility in the vadose zone and underlying unconfined aquifer. Contaminant mobility classes were used rather than the individual mobility of each contaminant because of the uncertainty involved in determining the mobility of individual constituents. The mobility classes were selected based on relatively narrow ranges of mobility. Some of the constituents, such as iodine and technetium, would

move at the same rate as water whether in the vadose zone or underlying groundwater. The movement of other constituents in water, such as americium, cesium, plutonium, and strontium, would be retarded by interaction with soil and rock.

The constituents considered in this assessment have a broad range of mobility when their affinity to being sorbed during transport in the vadose zone and groundwater environment is considered. The flow and transport models used in this analysis account for these differences in mobility by the use of a factor commonly referred to as the retardation factor (Rf). This factor, which relates the velocity of the contaminant to the velocity of pore water, is typically calculated using a distribution coefficient, or  $K_d$ , which has units of mL/g. This parameter is a measure of sorption and is the ratio of the quantity of the solute adsorbed per gram of solid to the amount of solute remaining in solution (Kaplan et al. 1995). Values of  $K_d$  for the constituents range from 0 mL/g (in which the contaminant movement in water is not retarded) to more than 40 mL/g (in which the contaminant moves at a much slower rate than water).

The constituents in the LLW inventory were grouped and modeled according to well-established  $K_d$ s for each constituent, or a conservative  $K_d$  where a range of  $K_d$ s is known for a particular constituent. The constituent mobility classes, based on mobility and examples of common or potential constituents of concern, are described in the following text. A complete list of solid LLW constituents by  $K_d$  is provided in Volume II, Appendix G. The constituent mobility classes used for modeling include:

- **Mobility Class 1** – Contaminants were modeled as non-sorbing (that is,  $K_d = 0$ ) and would not be retarded in the soil-water system. Contaminant  $K_d$  values in this group are within the range of 0 to 0.59 mL/g and include all the isotopes of iodine, technetium, selenium, chlorine, and tritium.
- **Mobility Class 2** – Contaminants were modeled as slightly sorbing (that is,  $K_d = 0.6$ ) and would be slightly retarded in the soil-water system. Contaminant  $K_d$  values in this group are within the range of 0.6 to 0.99 mL/g and include all the isotopes of uranium and carbon.
- **Mobility Class 3** – Contaminants were modeled as slightly more sorbing (that is,  $K_d = 1$ ). Contaminant  $K_d$  values in this group are within the range of 1.0 to 9.9 mL/g and include all the isotopes of barium.
- **Mobility Class 4** – Contaminants were modeled as moderately sorbing (that is,  $K_d = 10$ ). Contaminant  $K_d$  values in this group are within the range of 10 to 39.9 mL/g and include all the isotopes of neptunium, palladium, protactinium, radium, and strontium.
- **Mobility Class 5** – Contaminants were modeled as strongly sorbing (that is,  $K_d = 40$ ). Contaminant  $K_d$  values in this group are 40 mL/g or greater and include all the isotopes of actinium, americium, cobalt, curium, cesium, iron, europium, gallium, niobium, nickel, lead, plutonium, samarium, tin, thorium, and zirconium.

Estimated inventories of hazardous chemical constituents associated with LLW and MLLW disposed of after 1988 being considered under each alternative group would be expected to be found at trace levels. MLLW, which would be expected to contain the majority of hazardous chemical constituents, would

undergo predisposal solidification to stabilize waste forms and containment and thermal treatment to remove organic chemical components of the MLLW. This waste treatment would be done to meet current waste acceptance criteria and land disposal restrictions before being disposed of in permitted MLLW facilities. Consequently, potential groundwater quality impacts from these constituents would not be expected to be substantial.

Analysis of MLLW inventories for this assessment did identify two exceptions that included lead and mercury inventories associated with the projected MLLW that were estimated at 336 kg (741 lb) and 2.5 kg (5.5 lb), respectively. Because of its affinity to be sorbed into Hanford sediments, lead falls within Mobility Class 5 ( $K_d = 40$  mL/g) and would not release to groundwater within the 10,000-year period of interest. The inventory estimated for mercury is assumed to be small enough that it would not release to groundwater in substantial concentrations. Even the most conservative estimates of release would yield estimated groundwater concentrations at levels of two orders of magnitude below the current drinking water standard for mercury of 0.002 mg/L.

LLW disposed of prior to October 1987 may contain hazardous chemical constituents, but no specific requirements existed to account for or report the content of hazardous chemical constituents in this category of LLW. As a consequence, analysis of these constituents and estimated impacts based on the limited amount of information on estimated inventories and waste disposal locations would be subject to uncertainty at this time. (Additional discussion on uncertainties is presented in Section 3.5.) These facilities are part of the LLW and MLLW facilities in the LLW management Areas (LLWMAs) 1 through 4 that currently are being monitored under RCRA interim status programs. Final closure or remedial investigation of these facilities under RCRA (42 USC 6901) and/or CERCLA (42 USC 9601) guidelines could involve further analysis of the potential impacts of the chemical components of these inventories.

In response to comments received during the public comment periods on the drafts of the HSW EIS, efforts were made to develop an estimate of quantities of potentially hazardous chemicals in previously buried LLW so that an initial analysis of potential impacts of such chemicals on groundwater quality could be evaluated. The estimation of these inventories, which used a waste stream analysis estimation method, is summarized in the Technical Information Document (FH 2004). This initial assessment of the estimated hazardous chemical inventory in pre-1988 buried wastes is provided in Section 5.3.7 and Section G.6 in Volume II, Appendix G.

The source term is the quantification of when and which constituents (by mass or activity) would be released. This source term includes the water flux into the vadose zone that results from precipitation infiltrating the waste and mass or activity solubilized from dissolution of waste in the HSW disposal facilities. A detailed description of the source term and the rates of release of constituents into the groundwater can be found in Volume II, Appendix G. Methods used for calculating source release and transport of constituents in the vadose zone and groundwater also are described in Volume II, Appendix G.



### 5.3.2.1 Previously Disposed of Waste and Category 1 Low-Level Waste

Previously disposed of LLW and Cat 1 LLW were evaluated using similar modeling approaches. Previously disposed of LLW consists of waste emplaced in the HSW disposal facilities from 1962 to 1970 and between 1970 and 1987; Cat 1 LLW consists of waste emplaced since 1988 and forecasted to be emplaced in the future in the 200 East Area and the 200 West Area.

Assumptions for analysis of these LLW types include:

- All LLW would be buried by 2046. At the beginning of the analysis period, all constituents of concern were assumed to be available for transport via infiltrating precipitation to the vadose zone and for eventual arrival at the groundwater.
- The start of release is variable and dependent on the waste category. Because of uncertainties in the use of waste containers and containment prior to 1995, releases for the pre-1970 LLW, 1970-1987 LLW, and 1988–1995 LLW were conservatively approximated by initiating waste releases in 1966, 1976, and 1996, respectively. Since 1995, the use of more robust waste containment and waste forms (that is, the use of steel drums and steel boxes for Cat 1 LLW and the use of macroencapsulated grouting and high-integrity containers for Cat 3 LLW) has become a standard practice. Thus the start of release of all LLW and MLLW disposed of after 1995 was assumed to be delayed at least until the time of site closure in 2046.
- Source-term release for the LLW was estimated using the soil-debris release model. In this model, the waste, itself, was assumed to have the same hydraulic characteristics of the surrounding soil materials. The inventory in the LLW was conservatively assumed to be immediately available for leaching and would be leached out of the HSW disposal facilities at the assumed infiltration rate.
- For all alternatives involving LLW previously disposed of before 1996, the soil-debris release model assumed an infiltration rate of 5 cm/yr during the period of operations before year 2046. This assumption of infiltration provides conservative estimates of waste release to groundwater for earlier disposals (prior to 1995) when waste containment was not as robust. This assumed release model infiltration rate was used for the pre-1970 LLW, the 1970–1988 LLW, and the 1988–1995 LLW.
- For all alternatives involving wastes disposed of after 1995, the soil-debris release model assumed sufficient waste containment to delay release until after site closure.
- For Alternative Groups A through E, all waste disposal sites were assumed to be covered with a Modified RCRA Subtitle C Cover system. To approximate the effect of the cover on waste release, the following assumed infiltration rates were used in the waste release modeling. For 500 years after site closure, an infiltration rate of 0.01 cm/yr was used to approximate the effect of cover emplacement over the wastes and its potential impact on reducing infiltration. After 500 years, it was assumed that the cover would begin to degrade. Between 500 and 1000 years after site closure, infiltration rates were increased from 0.01 cm/yr to 0.5 cm/yr to approximate a 500-year period of cover degradation and return to an infiltration rate reflective of natural vegetated surface soil

conditions over the wastes. The final rate of 0.5 cm/yr was used for the remaining 9,000-year period of analysis. For the No Action Alternative, the release modeling from these wastes used an infiltration rate of 0.5 cm/yr, which was assumed to be an appropriate infiltration rate for naturally vegetated surface soil conditions that would persist under this alternative after site closure.

Additional analyses were performed to provide perspective on potential impacts using two additional assumptions: 1) no cover system is installed and 2) a cover system is used and remains intact for the entire period of analysis (see Section 5.3.5.).

- A specific case of leaching was used to estimate the release of uranium from the LLW. For uranium, the release was controlled at a solubility limit of 64 mg/L, a conservative estimate of uranium solubility at Hanford estimated by Wood et al. (1995) for LLW in the 200 West Area.
- During the post-closure period (that is, after 2046), the infiltration rate used for vadose zone flow was assumed to be 0.5 cm/yr to reflect natural recharge in the surrounding environment of naturally vegetated surface soil conditions. In the absence of artificial recharge, vadose simulation results based on this assumed infiltration rate indicated a travel time to the water table of about 560 years in the 200 East Area and 900 years in the 200 West Area.
- The thickness of the LLW was assumed to be 6 m (20 ft) for disposal in the existing trenches and 15.6 m (51 ft) for the enhanced design waste trenches (deeper, wider trenches in Alternative Group A; single expandable trenches in Alternative Group C; and in the lined modular facility in Alternative Groups D<sub>1</sub>, D<sub>2</sub>, D<sub>3</sub>, E<sub>1</sub>, E<sub>2</sub>, and E<sub>3</sub>).
- For a number of the alternative groups, the analysis considered the use of liner systems to control waste release during the period of operations. However, no specific credit for the effect of these liner systems was considered in this long-term analysis. Although the liner systems, as described in Section 3.1, might last (contain leachate for removal) for several hundreds of years if properly managed, this analysis assumed that the emplaced liners would fail during the 100-year active institutional control period and would have little effect on the long-term waste release during the 10,000-year period of analysis.

### 5.3.2.2 Cat 3 Low-Level Waste

Assumptions for analysis of Cat 3 LLW that differs from those of Cat 1 LLW follow:

- Because all Cat 3 LLW is either buried in high-integrity containers (HICs) constructed of concrete or disposed of by in-trench grouting, the calculations assumed a delay in contaminant release (the design lifetime of an individual HIC). Source-term releases of carbon-14 and iodine-129 were estimated using the soil-debris release model with the assumed delay in release to account for containment of the LLW in either HIC or in-trench grouting. In this model, the inventory in the LLW was conservatively assumed to be immediately available for leaching. The exception to this approach was technetium-99 and uranium in LLW. The technetium-99 LLW was assumed to be

disposed of within the HIC in a macroencapsulated grout form, and the release of technetium-99 was assumed to be controlled by diffusion through the grout.

- The leaching of uranium disposed of in cementitious waste forms (that is, in macroencapsulated grout or HICs) was based on a solubility controlled release model that used an assumed lower uranium solubility limit of 0.2 mg/L (Wood et al. 1996). This solubility limit, which is lower than the 64 mg/L used for leaching of uranium in non-cemented wastes, is a conservative representation of uranium solubility in the alkaline geochemical conditions created by the presence of cement in the disposal environment. Additional information on recent studies of leaching of uranium from cementitious waste forms is available from Krupka and Serne (1996) and Serne et al. (1996).

### **5.3.2.3 Mixed Low-Level Waste**

MLLW analyzed in this section includes waste emplaced since 1988 and waste forecasted to be emplaced in the future. Trenches 31 and 34 in LLBG 218-W-5 in the 200 West Area were constructed specifically for disposal of MLLW. MLLW in excess of the capacity of these trenches is assumed to be disposed of in newly constructed MLLW trenches in designated locations defined in Alternative Groups A through E.

Assumptions for analysis of MLLW that differs from those of Cat 1 LLW follow:

- Some of the MLLW would be disposed of in a matrix of macroencapsulated grout similar to Cat 3 LLW.
- The thickness of the MLLW disposed of in the 200 West Area in Trenches 31 and 34 within LLBG 218-W-5 was assumed to be 6 m (20 ft). Depth of the MLLW disposed of in the 200 East Area in the enhanced trench at other LLBG locations was assumed to be 15.6 m (51 ft).

### **5.3.2.4 Melters from the Waste Treatment Program**

Melters analyzed in this section are forecasted to be emplaced in a new 21-m (69-ft) deep disposal facility, which would be constructed in locations designated in Alternative Groups A through E.

Assumptions for analysis of melters that differ from those of MLLW follow:

- The depth of the melter disposal facility, wherever constructed, was assumed to be 21 m (69 ft), and the waste thickness was assumed to be 18.6 m (61 ft).
- The melters were assumed to be macroencapsulated in grout. Thus, the release of inventories of constituents contained within this waste was assumed to be controlled by the presence of grout. The release of technetium-99 was assumed to be controlled by diffusion using the diffusion-controlled release model. The release of uranium isotopes was assumed to be controlled by a solubility-controlled release models using a solubility limit of 0.2 mg/L. (This value is used for uranium release from other waste categories that use cementitious waste forms.) All of these waste release

assumptions would represent a conservative treatment of waste release for these melters since constituents contained within these wastes would be contained in thick heavy gauge steel and encapsulated and incorporated in a vitrified waste mass and would likely be controlled by a much lower release rate related to steel corrosion and glass degradation.

### **5.3.3 Use of ILAW Performance Assessment Calculations to Support the HSW EIS**

Potential impact results presented for ILAW disposal in this assessment were not based on independent calculations used in the previously described methodology, but rather on recent performance assessment (PA) calculations made for siting the ILAW HSW in the vicinity of the PUREX Plant, as summarized in Mann et al. (2001).

Under Alternative Groups A, C, D<sub>1</sub>, and E<sub>3</sub>, where ILAW disposal is sited near the PUREX facility, results of a sensitivity case in Mann et al. (2001) that analyzed the effect of 25,550 Ci of technetium-99 was used. This case reflected no technetium-99 removal from low-activity waste in the separation processes from the Waste Treatment Plant.

In this analysis, the results for the ILAW were superimposed directly onto the results of other waste categories calculated for this analysis at the operational area (the 200 East and West Areas and ERDF) and Columbia River LOAs, as appropriate for each alternative group. Thus where ILAW may be disposed of near the PUREX Plant (Alternative Groups A, C, D<sub>1</sub>, and E<sub>3</sub>), ILAW results were superimposed onto other potential waste category impacts at the 200 East Area SE LOA. Where ILAW is disposed of in the 200 East Area LLBGs (Alternative Group D<sub>2</sub>), ILAW results were superimposed onto other potential waste category impacts at the 200 East Area SE LOA.

For purposes of this analysis, water quality and associated human health impact results presented in Section 5.11 and Volume II, Appendix F for Alternative Group B (where the ILAW disposal facility is sited in an area south of the CWC) and Alternative Groups D<sub>3</sub>, E<sub>1</sub>, and E<sub>2</sub> (where the ILAW disposal facility is sited at ERDF) are based on simple scaling of comparative simulation results of source releases in these areas using the sitewide groundwater flow and transport model (see Section G.3.3.2 in Appendix G, Volume II). Groundwater concentrations and results of human health impacts summarized in the original performance assessment calculations described in Mann et al. (2001) were based on well intercept factors (WIFs) or dilution factors from a given areal flux of a hypothetical contaminant released to the unconfined aquifer from the ILAW disposal facility (Bergeron and Wurster 2000). The WIF is defined as the ratio of the concentration at a well location in the aquifer to the concentration of infiltrating water entering the aquifer. These WIFs are being used in conjunction with calculations of released contaminant fluxes through the vadose zone to estimate potential impacts from radiological and hazardous chemical contaminants within the ILAW disposal facility at LOAs.

Results of applying WIFs for the three postulated ILAW disposal locations (see Section 3.3.2 in Appendix G, Volume II) suggest that predicted groundwater concentrations would be a factor of about 3 higher at the 1-km (0.6-mi) LOA downgradient of the HSW disposal site locations (south of CWC and at

ERDF) relative to a comparable location downgradient from the PUREX location. These higher-predicted concentrations would be consistent with differences in hydrogeology at these two locations relative to conditions found near the PUREX Plant. Near the PUREX Plant, the upper part of the unconfined aquifer is largely composed of very permeable sediments associated with the Hanford formation. Whereas, at the ERDF and CWC locations, the upper part of the unconfined aquifer is made up of less permeable sand and gravel sediments associated with the Ringold sediments.

These scaling factors would apply for both the Lower Bound and Upper Bound waste volumes since the ILAW volume and inventory is assumed to be the same for both cases. Peak concentrations estimated near the Columbia River from these alternative locations of disposal would be about 20 and 10 percent lower, respectively, than was calculated from releases near the PUREX location. The reductions in concentrations levels would be consistent with the longer flow path to the Columbia River.

The methods used to adapt the PA results to the analysis in the HSW EIS are provided in Volume II, Appendix G, Section G.3.

The technetium-99 inventory (25,550 Ci) used in the HSW EIS is a factor of 4.4 higher than the estimated inventory (about 5,790 Ci) if technetium-99 removal occurred in the separation process. Potential groundwater impacts attributable to technetium-99 in ILAW based on the higher estimated inventory would be reduced to about 23 percent of estimated levels presented in the HSW EIS alternative groups analyses if the lower inventory were assumed.

### **5.3.4 Potential Long-Term Impacts on Groundwater Quality**

Of the suite of LLW constituents disposed of in the HSW disposal facilities, only technetium-99 and iodine-129 in Mobility Class 1 and carbon-14 and the uranium isotopes in Mobility Class 2 were considered to be in sufficient quantity, long-lived, and mobile enough to warrant detailed analysis of potential groundwater quality impacts. Although three of the constituents in Mobility Class 1—selenium, chlorine, and tritium—are considered to be very mobile, they were excluded from analysis because the total inventories for selenium and chlorine were considered negligible (less than  $1 \times 10^{-2}$  Ci); tritium was excluded because it has a relatively short half-life and would reach the groundwater from the HSW disposal facilities in very small quantities.

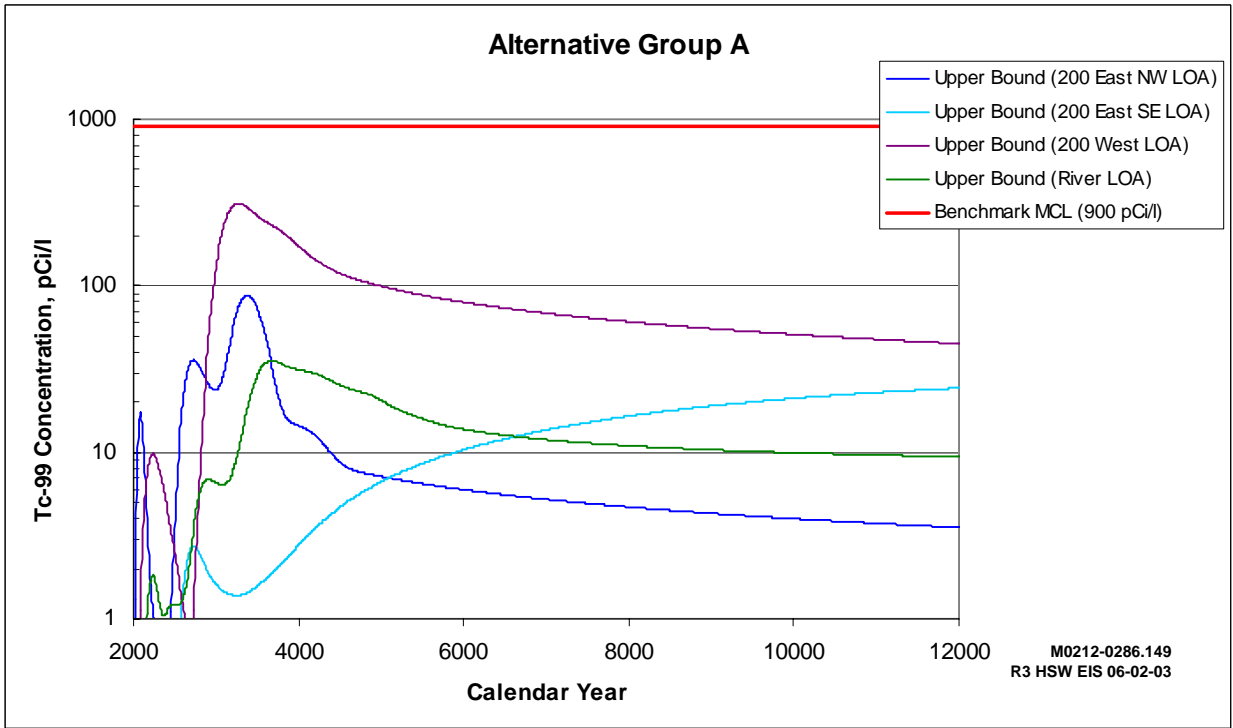
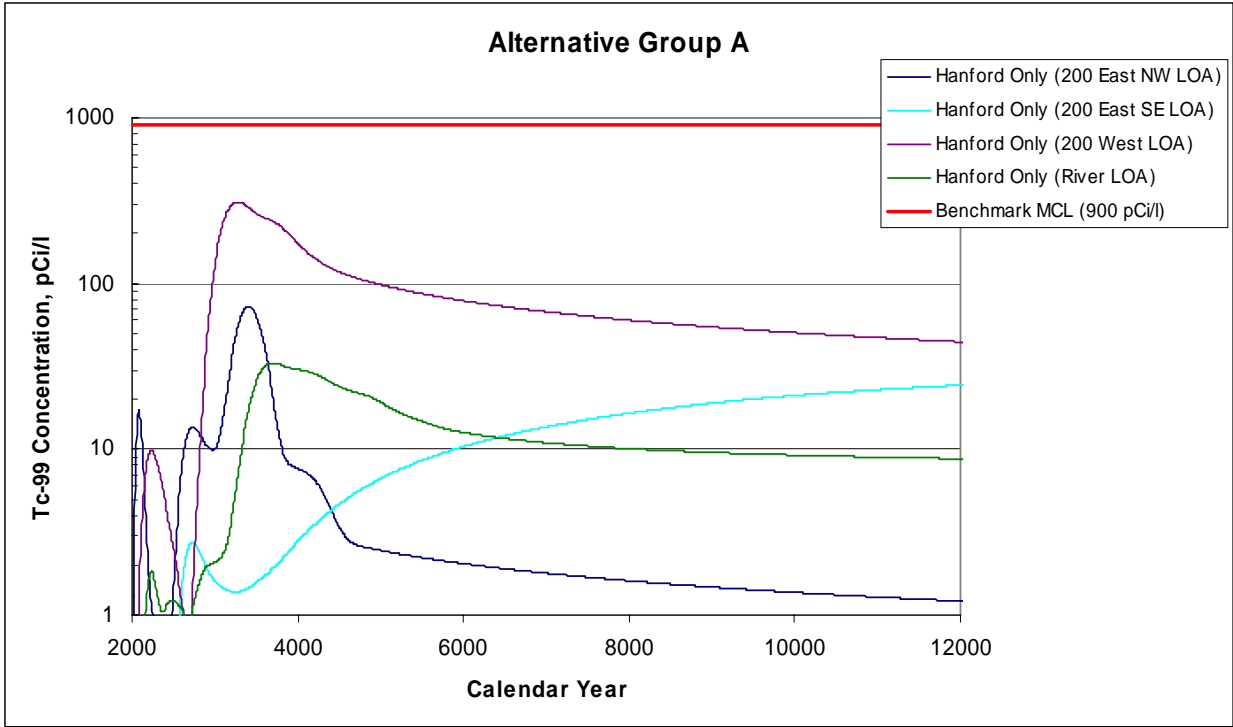
Estimates of transport times of constituents in Mobility Classes 3, 4, and 5 indicated their release through the thick vadose zone to the unconfined aquifer beneath the HSW disposal facilities would be beyond the 10,000-year period of analysis. Thus all constituents in these mobility classes were eliminated from further analysis.

Federal drinking water standards are used as benchmarks against which potential contamination levels may be compared. For the contaminants of interest, the Federal Drinking Water Standards (40 CFR 141.16) are based on EPA's calculated dose equivalent of 4 mrem/yr to the maximally exposed internal organ or total body. Effective December 8, 2003, however, the uranium standard is 30 µg/L,

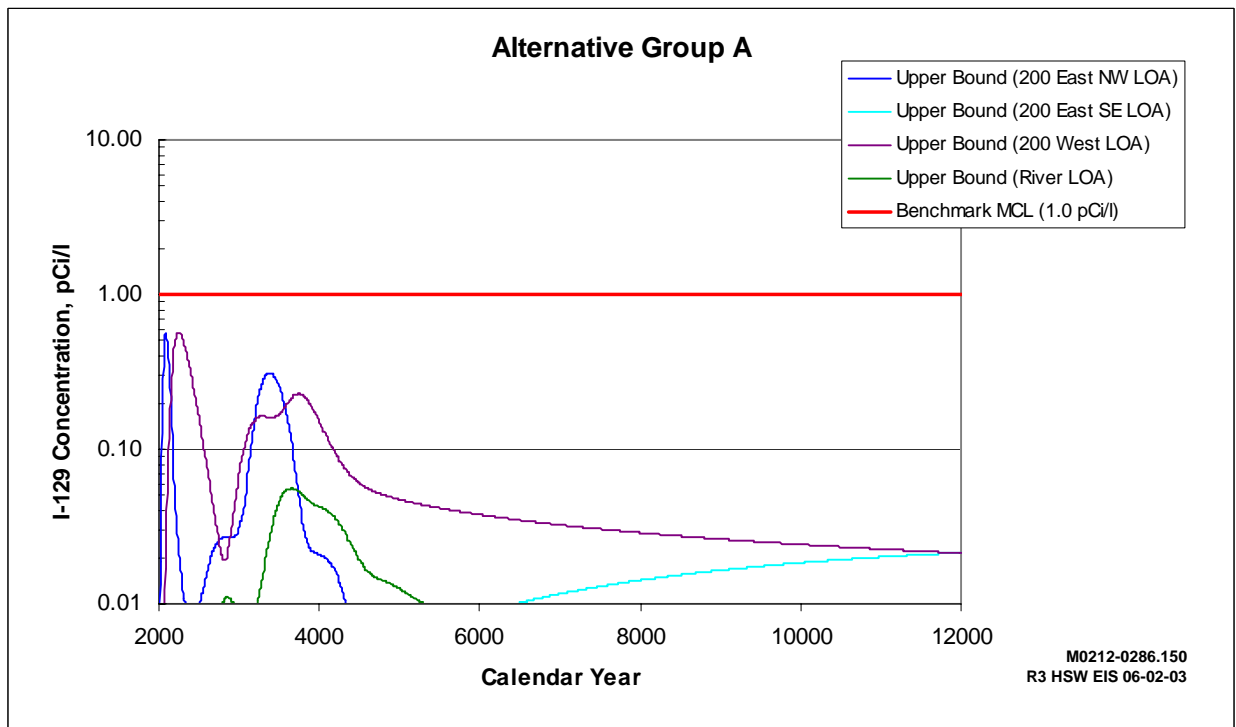
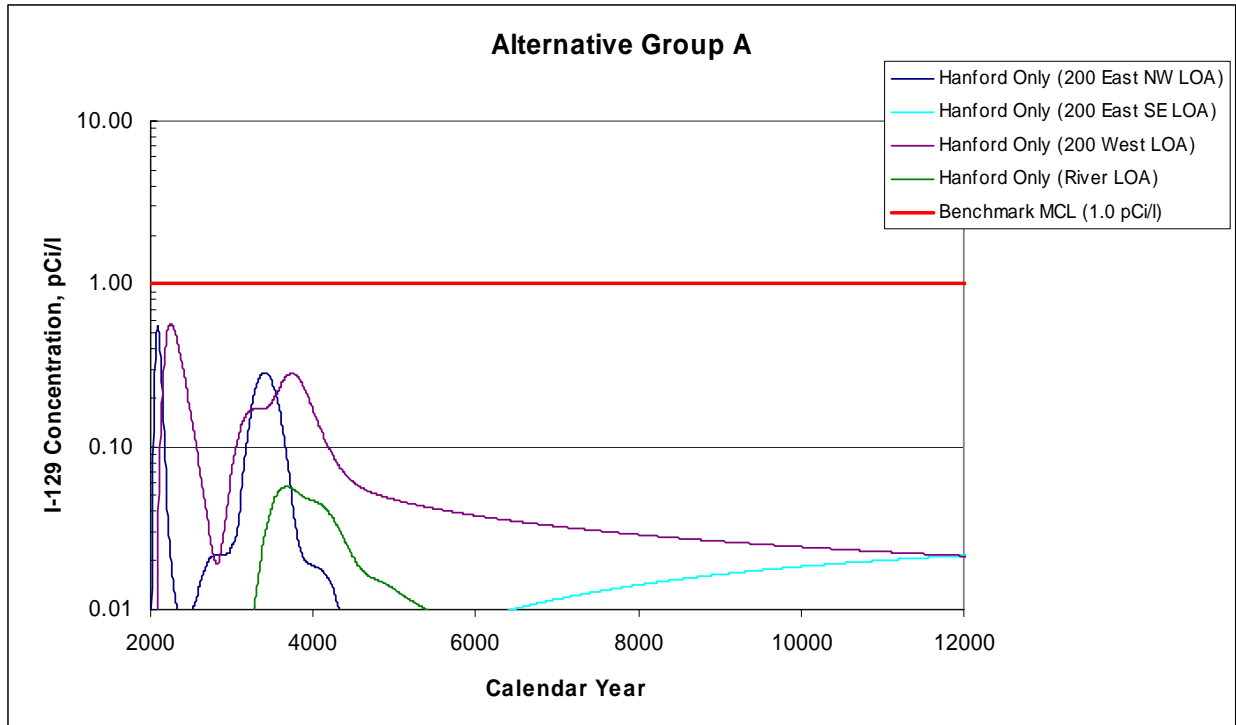
based on chemical toxicity that is more restrictive than the radiological dose standard (65 FR 76708). Drinking water standards for Washington state are stated in WAC 246-290. Federal standards are given in 40 CFR 141 and 40 CFR 143.

Concentrations of key constituents (primarily technetium-99 and iodine-129) for all Hanford solid waste types disposed of in the 200 Areas, at ERDF, and near the PUREX Plant for the LOAs by alternative group over 10,000 years for the Hanford Only and Upper Bound waste volumes are provided in Figures 5.3 to 5.21. These results represent the incremental potential impacts from wastes considered in this EIS (potential cumulative impacts of these wastes combined with other Hanford sources are presented in Section 5.14). For reference, benchmark maximum contaminant levels (MCLs) for technetium-99 and iodine-129 are 900 pCi/L and 1 pCi/L, respectively. Because of the variation in the location of the different waste types and category releases for a given alternative group, the estimated maximum concentrations calculated from a specific waste category release may not correspond to the same point on the LOA for every waste category and alternative group. Combined concentration levels presented in the following sections for each LOA and alternative group reflect the summation of estimated concentration levels regardless of their position on the LOA. As indicated in the following figures, most of the variation in groundwater radionuclide concentrations among the alternative groups resulted from proposed locations and configurations for new disposal facilities; differences between the Hanford Only and Upper Bound waste volumes were minimal.

Summary level discussions of potential impacts on groundwater quality for each alternative group are presented in the following sections. These discussions primarily focus on quantitative estimates of potential impacts related to releases of technetium-99 and iodine-129. Qualitative discussion of the potential impacts from carbon-14 and the uranium isotopes also is provided. Potential human health impacts are presented in Section 5.11.

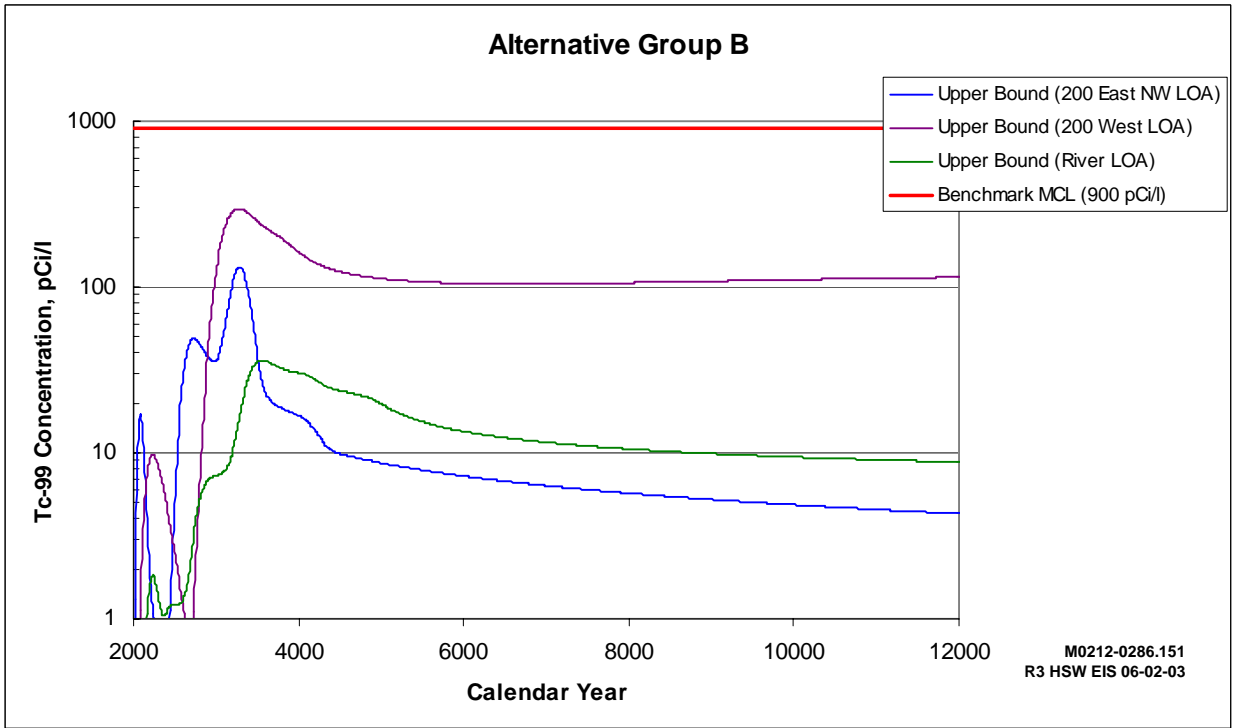
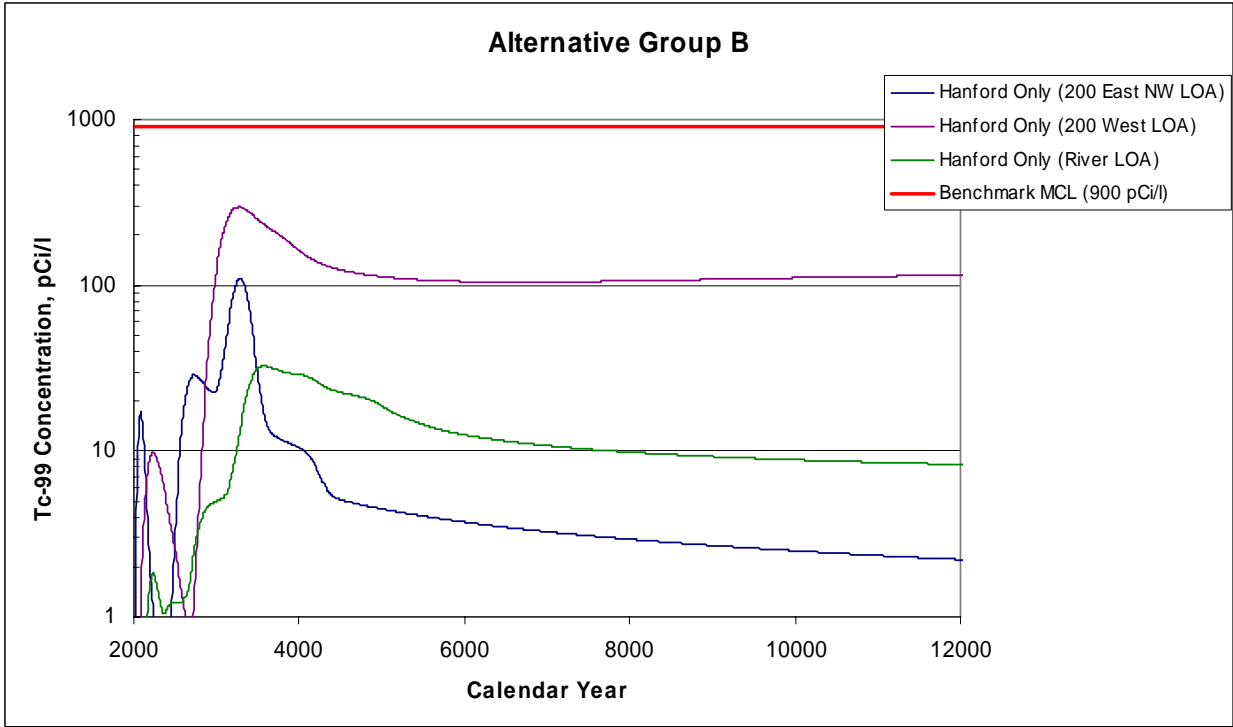


**Figure 5.3.** Technetium-99 Concentration Profiles at Various Lines of Analysis (Alternative Group A – Hanford Only and Upper Bound Waste Volumes)

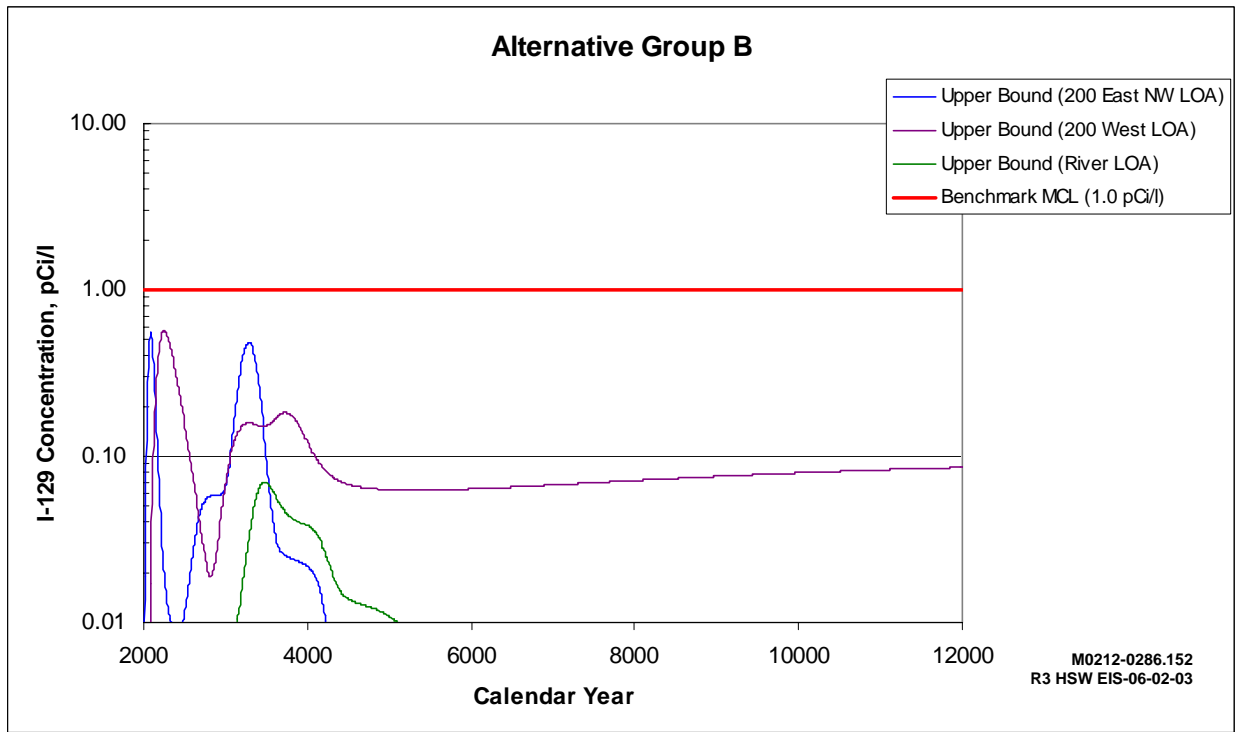
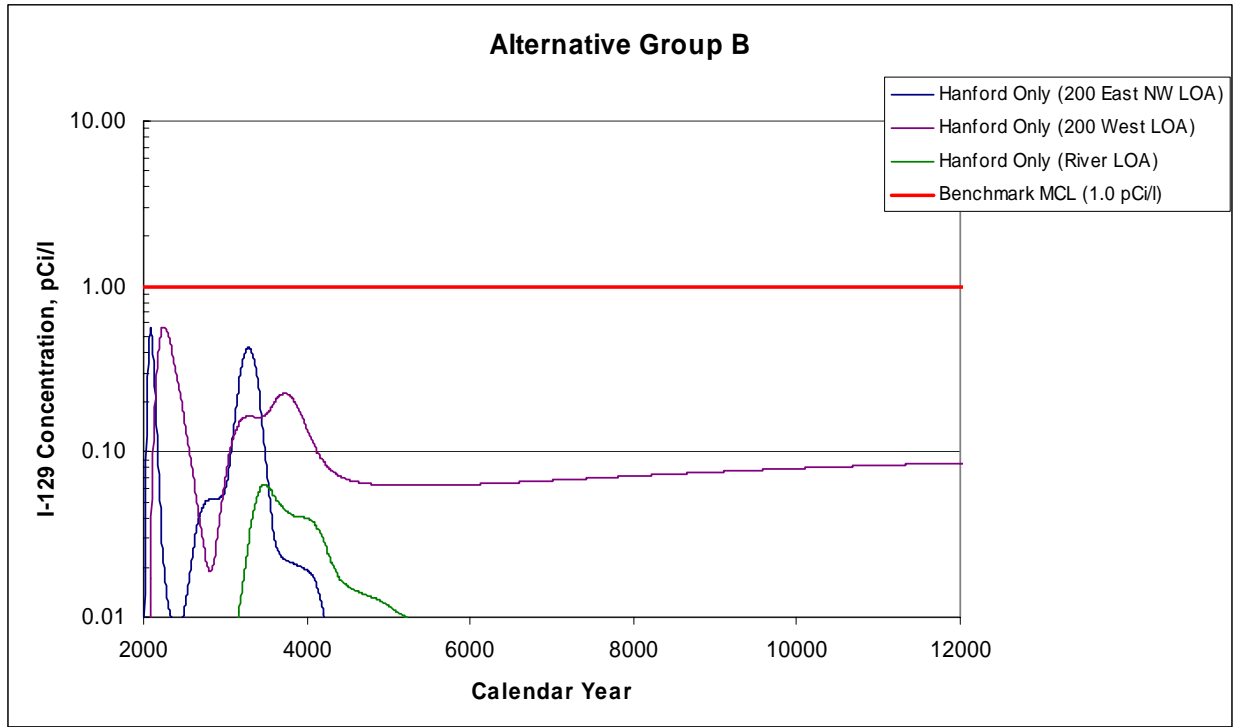


**Figure 5.4.** Iodine-129 Concentration Profiles at Various Lines of Analysis (Alternative Group A – Hanford Only and Upper Bound Waste Volumes)

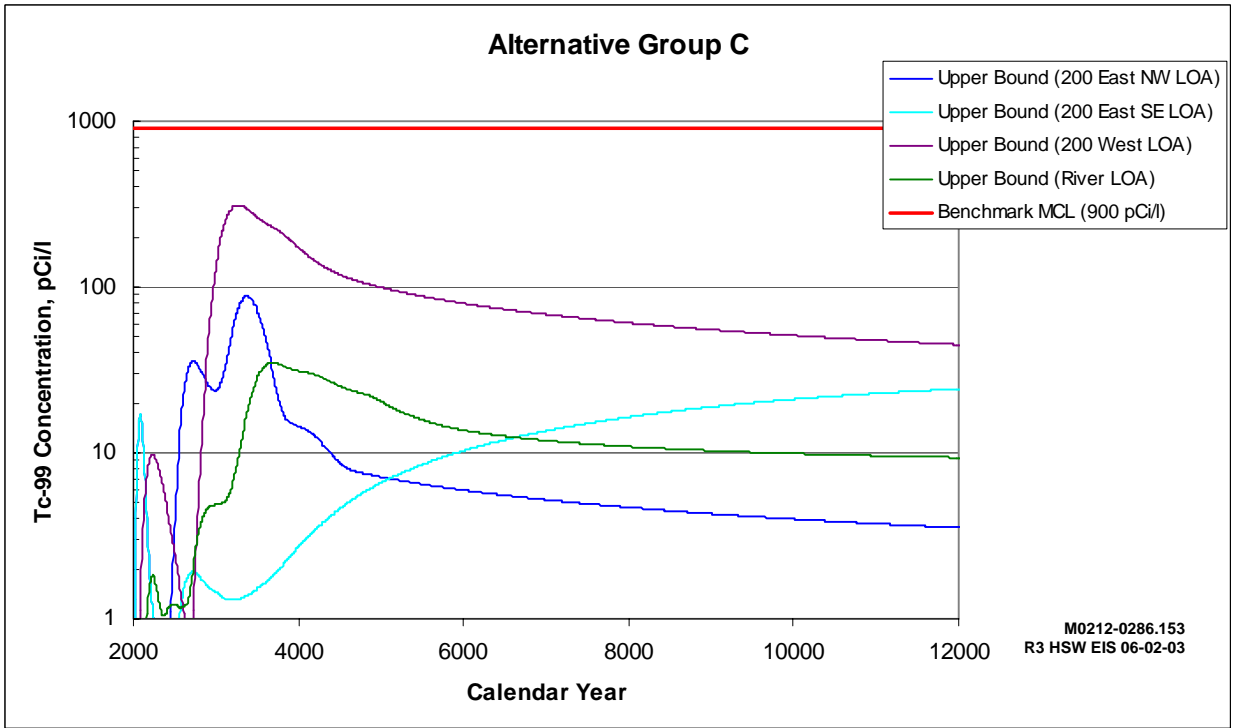
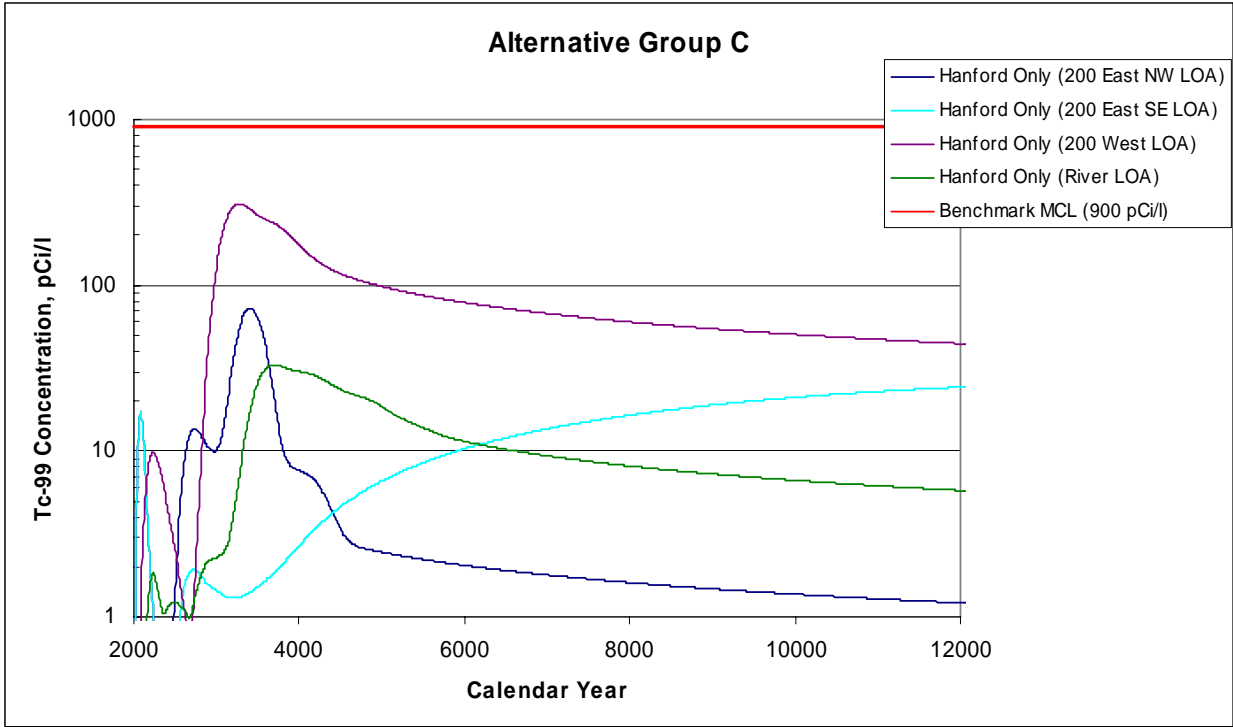




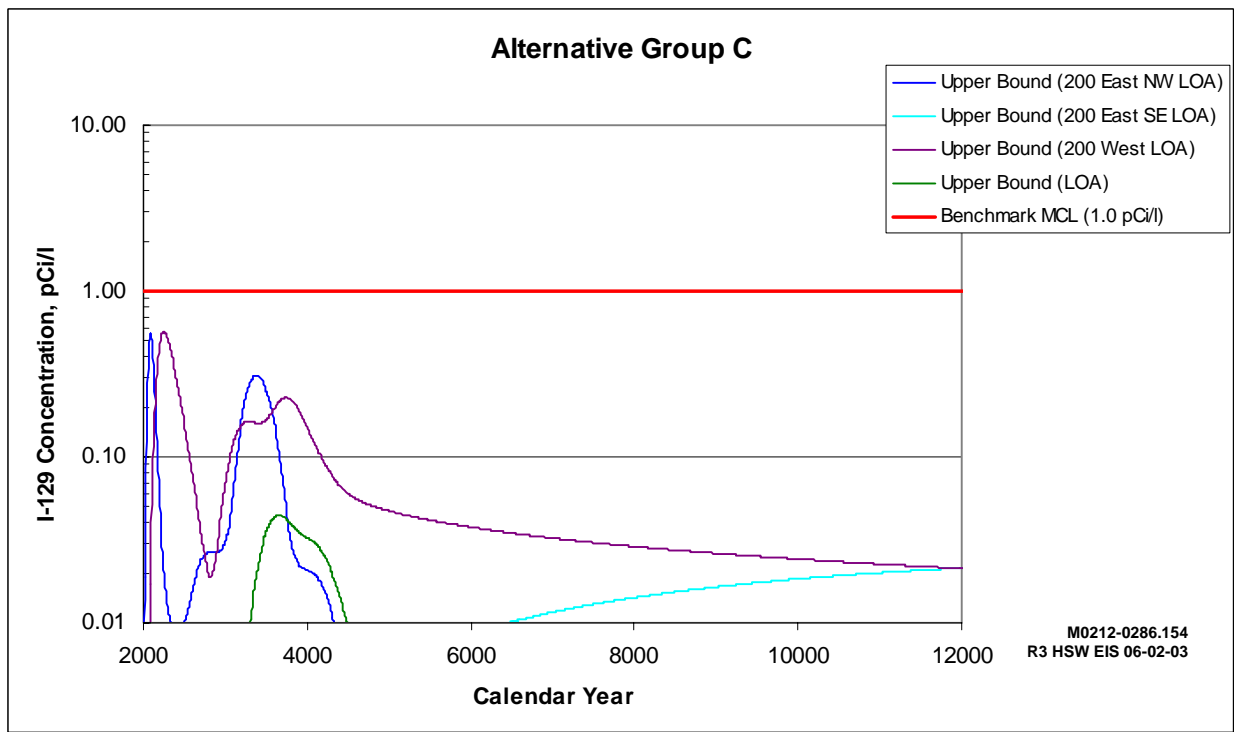
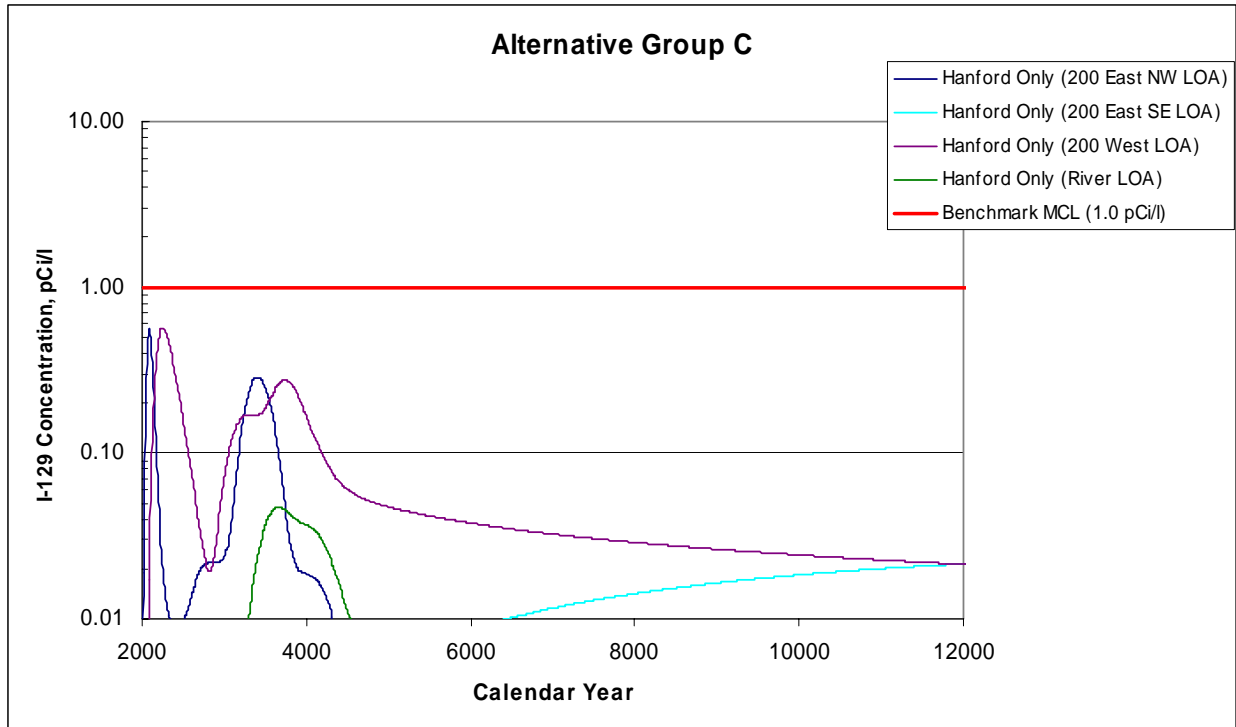
**Figure 5.5.** Technetium-99 Concentration Profiles at Various Lines of Analysis (Alternative Group B – Hanford Only and Upper Bound Waste Volumes)



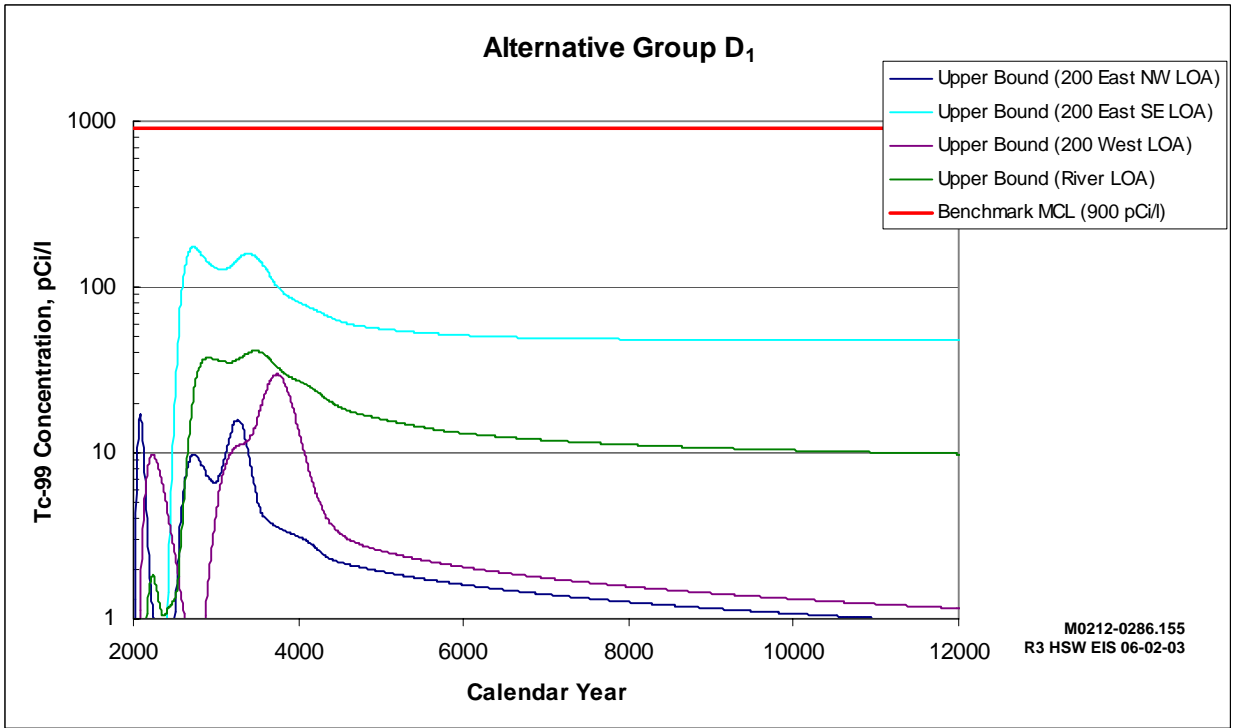
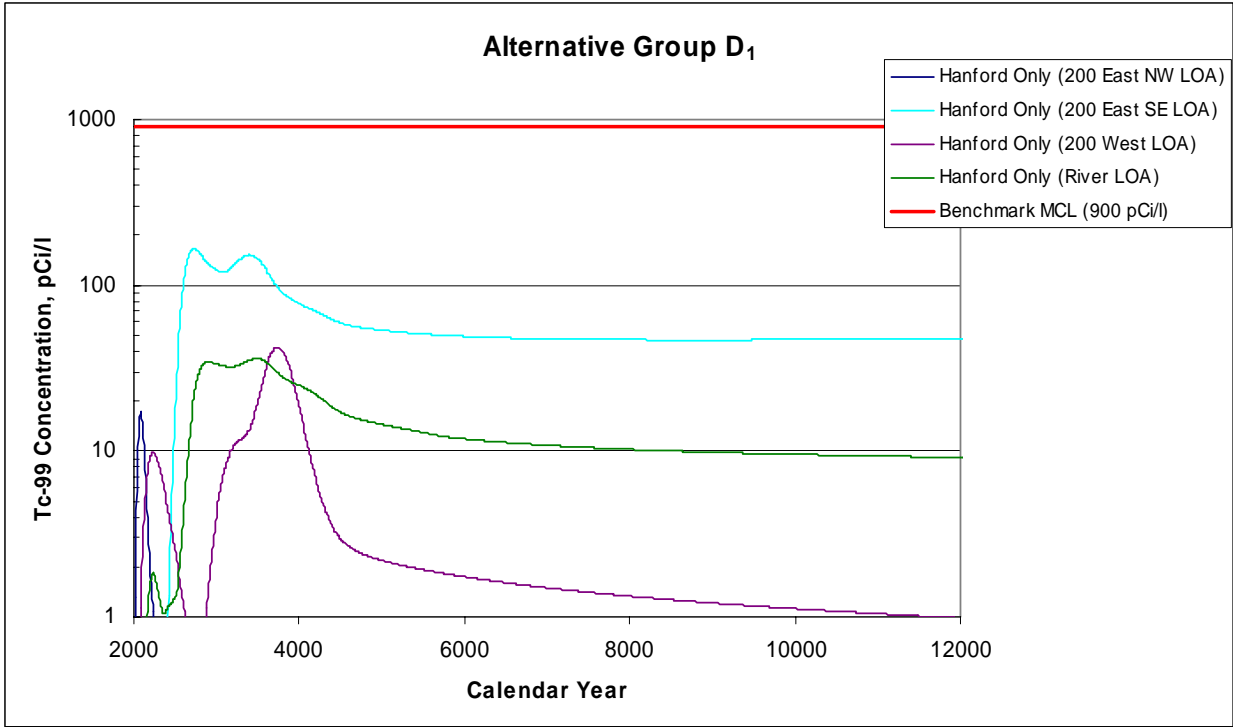
**Figure 5.6.** Iodine-129 Concentration Profiles at Various Lines of Analysis (Alternative Group B – Hanford Only and Upper Bound Waste Volumes)



**Figure 5.7.** Technetium-99 Concentration Profiles at Various Lines of Analysis (Alternative Group C – Hanford Only and Upper Bound Waste Volumes)

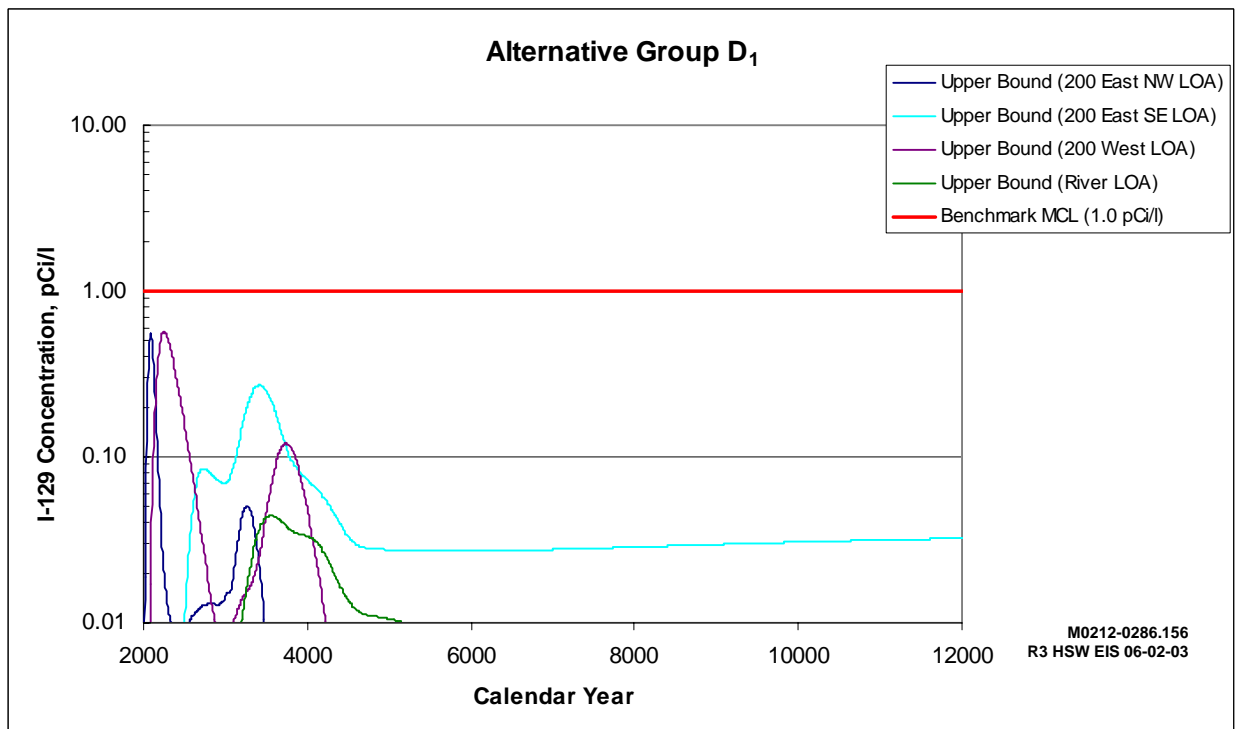
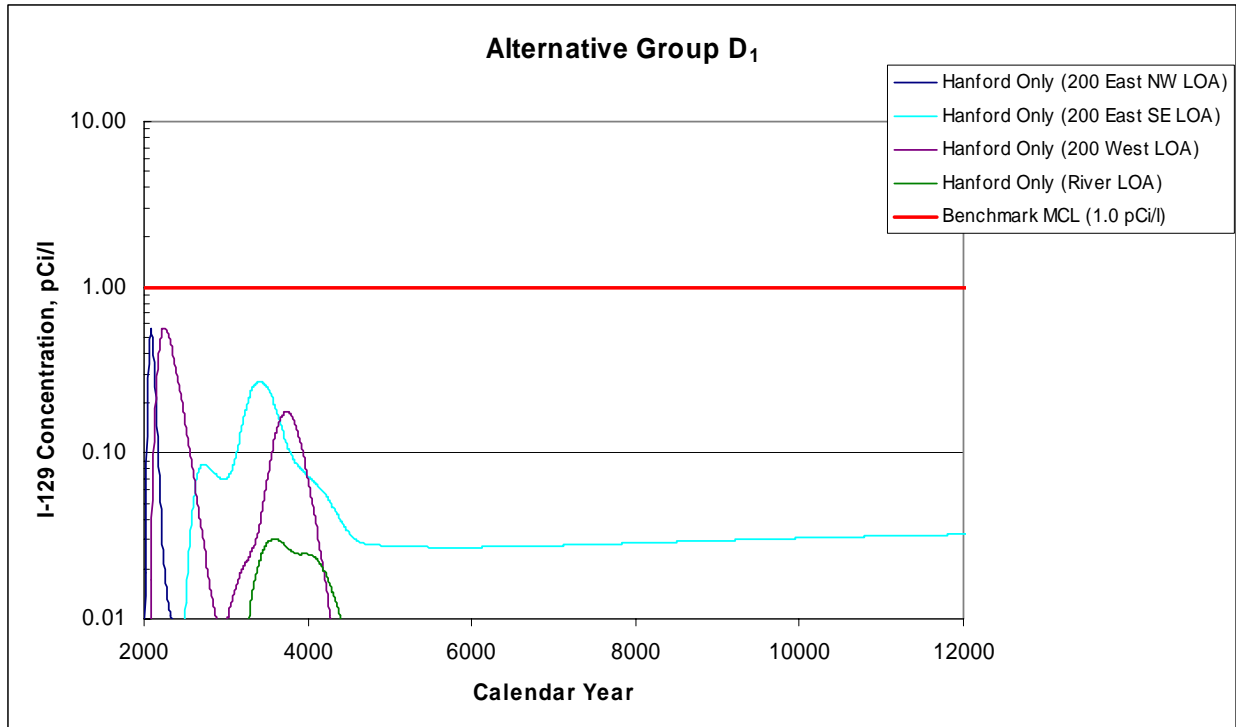


**Figure 5.8.** Iodine-129 Concentration Profiles at Various Lines of Analysis (Alternative Group C – Hanford Only and Upper Bound Waste Volumes)

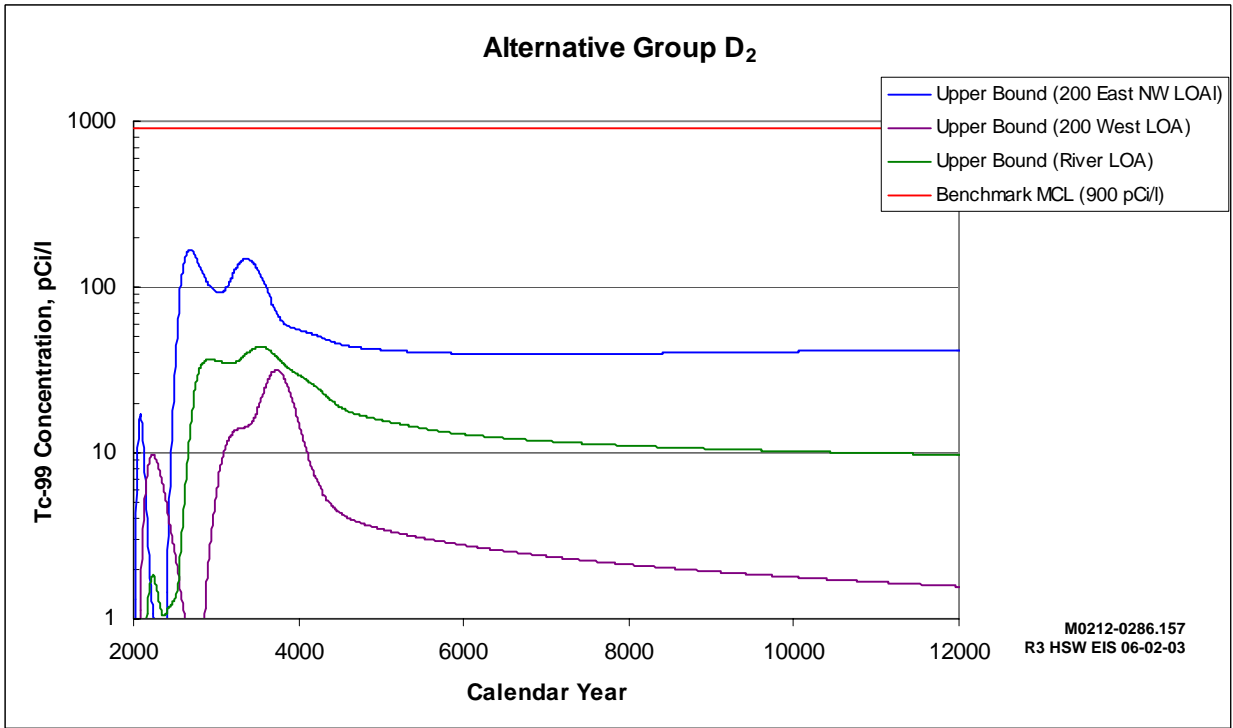
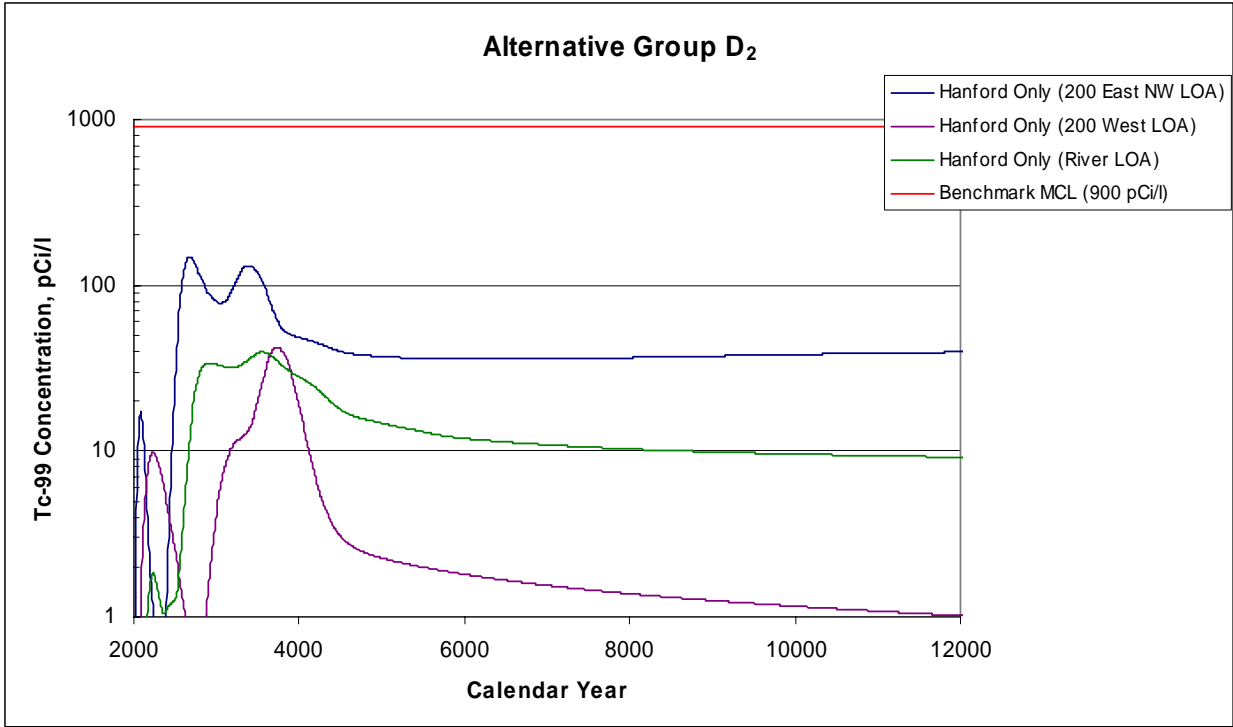


M0212-0286.155  
R3 HSW EIS 06-02-03

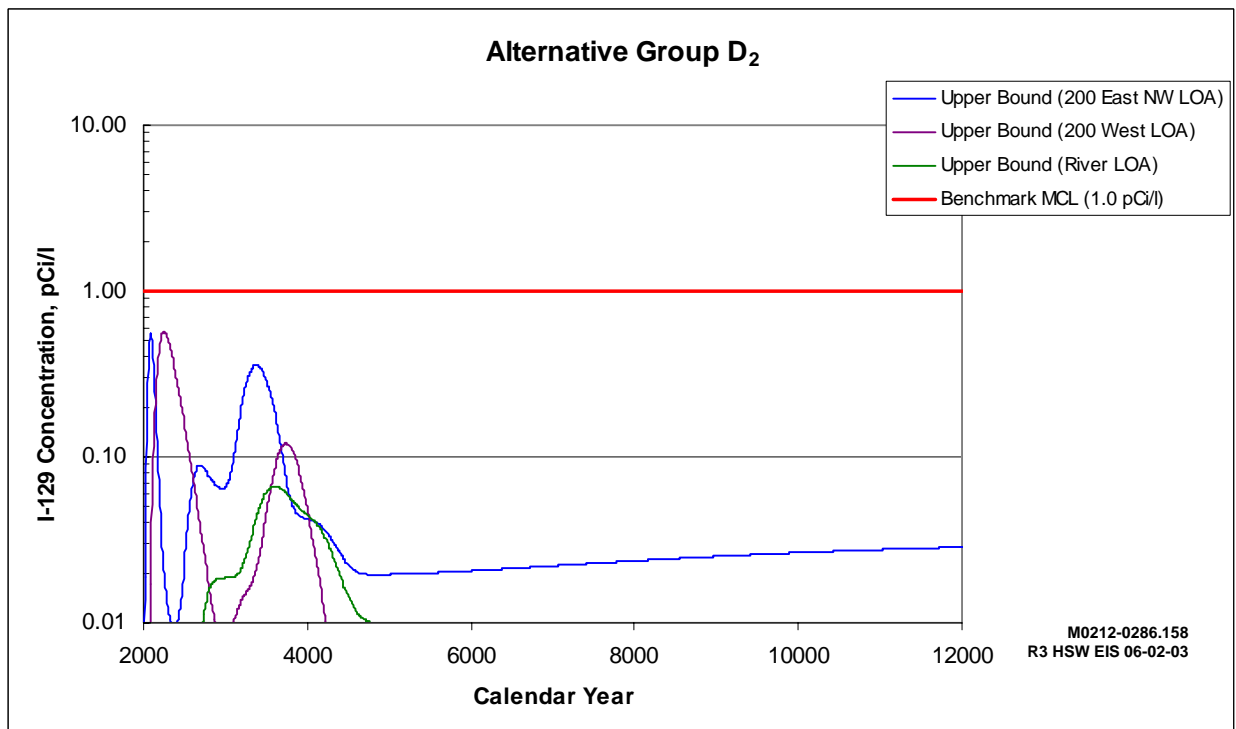
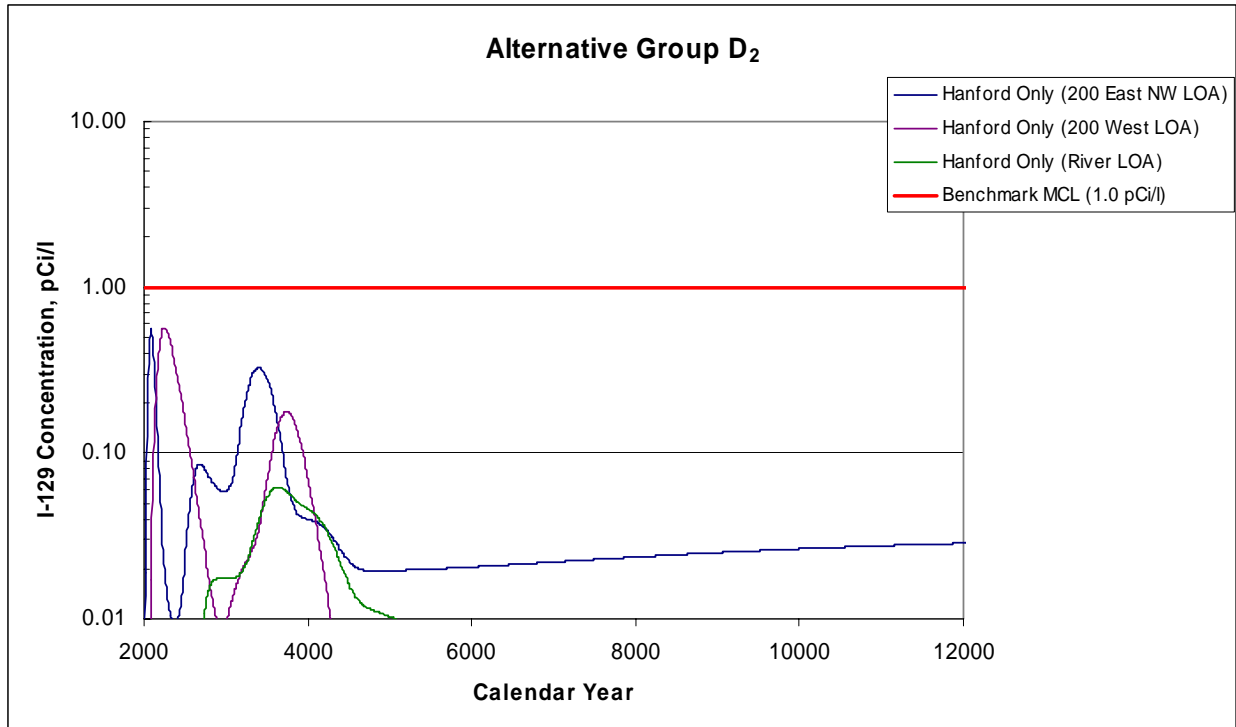
**Figure 5.9.** Technetium-99 Concentration Profiles at Various Lines of Analysis (Alternative Group D<sub>1</sub> – Hanford Only and Upper Bound Waste Volumes)



**Figure 5.10.** Iodine-129 Concentration Profiles at Various Lines of Analysis (Alternative Group D<sub>1</sub> – Hanford Only and Upper Bound Waste Volumes)

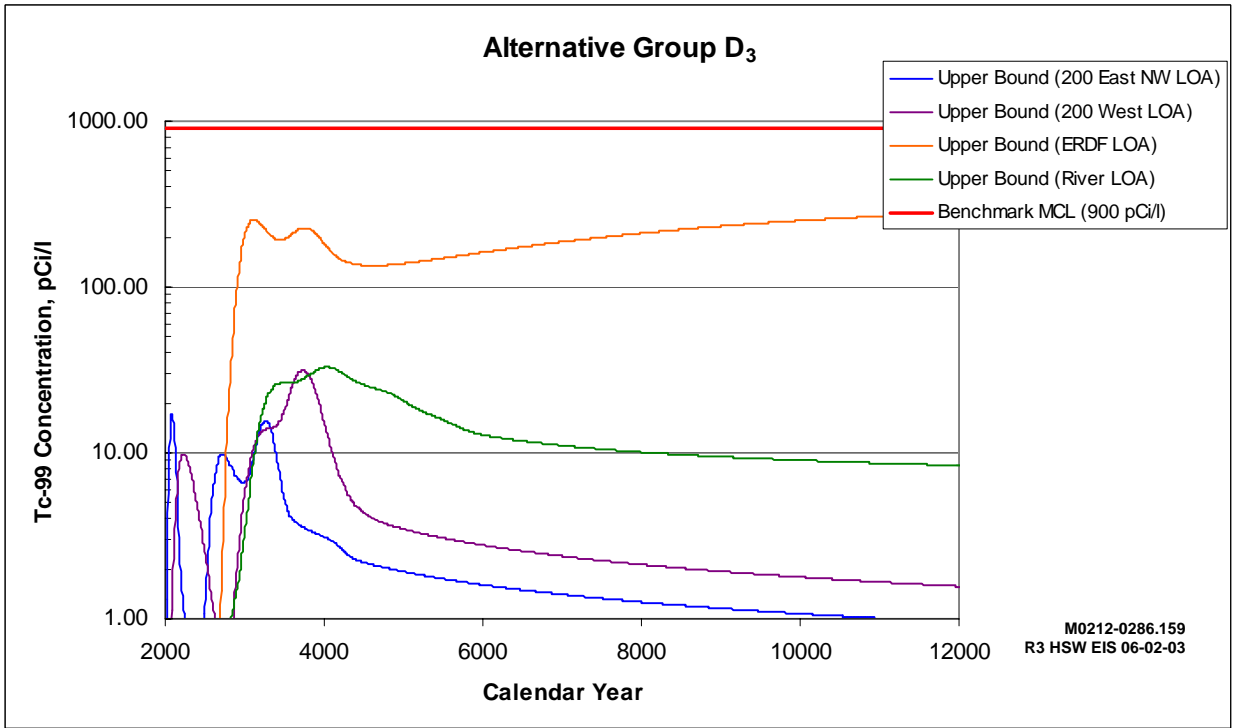
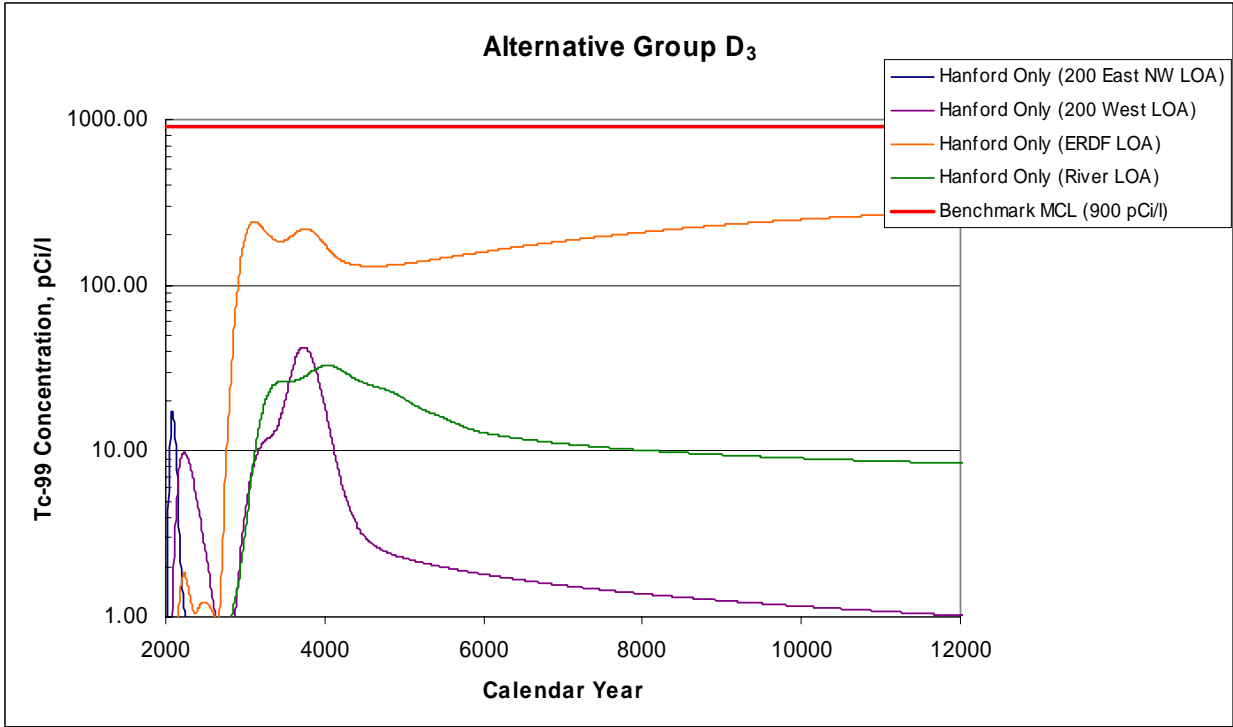


**Figure 5.11.** Technetium-99 Concentration Profiles at Various Lines of Analysis (Alternative Group D<sub>2</sub> – Hanford Only and Upper Bound Waste Volumes)

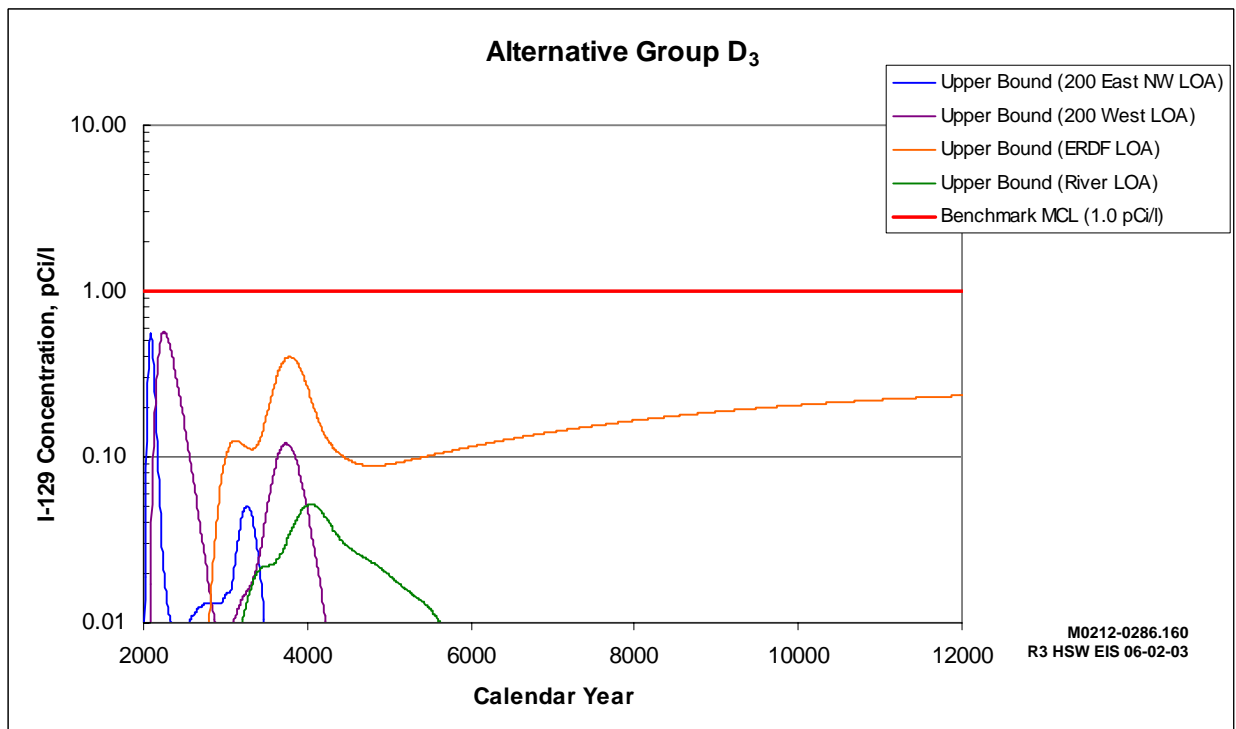
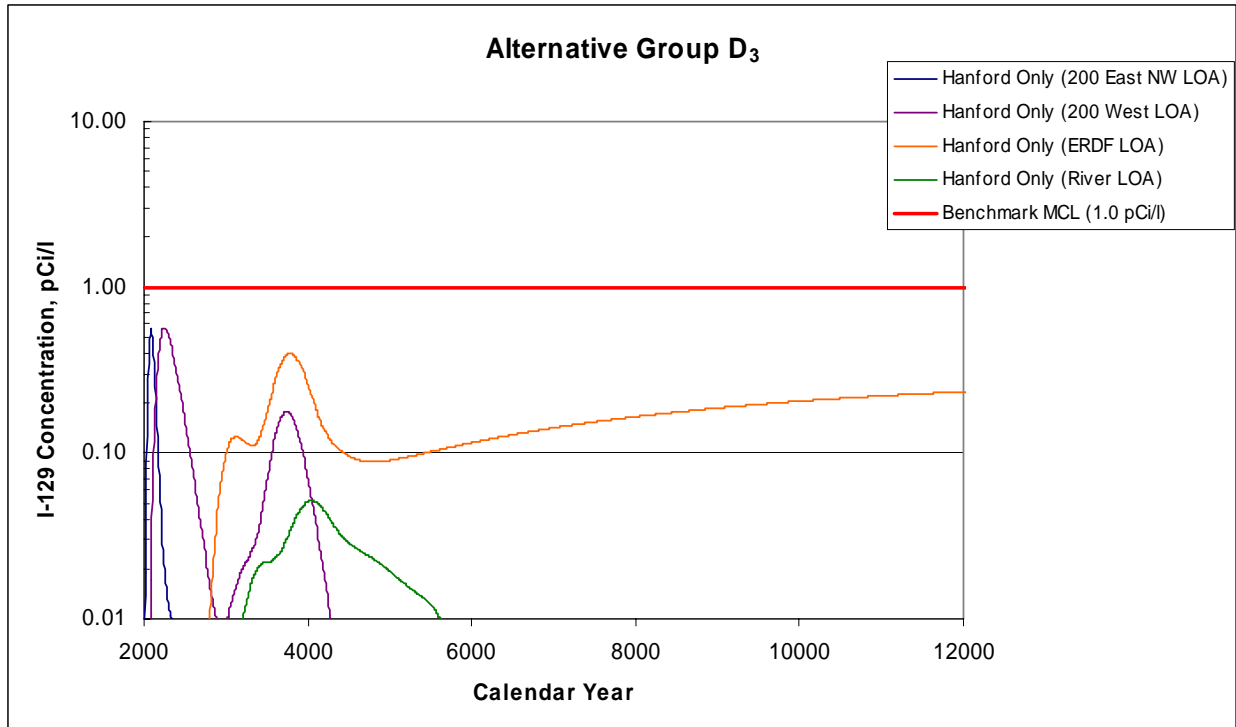


**Figure 5.12.** Iodine-129 Concentration Profiles at Various Lines of Analysis (Alternative Group D<sub>2</sub> – Hanford Only and Upper Bound Waste Volumes)

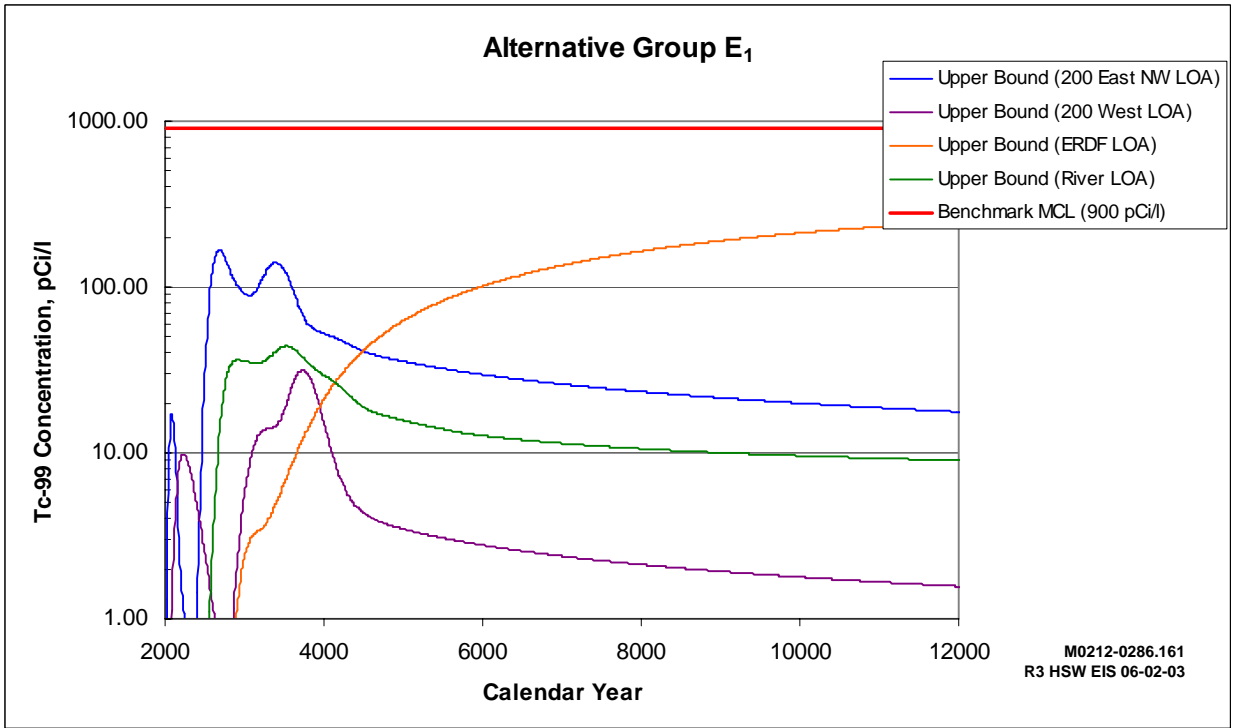
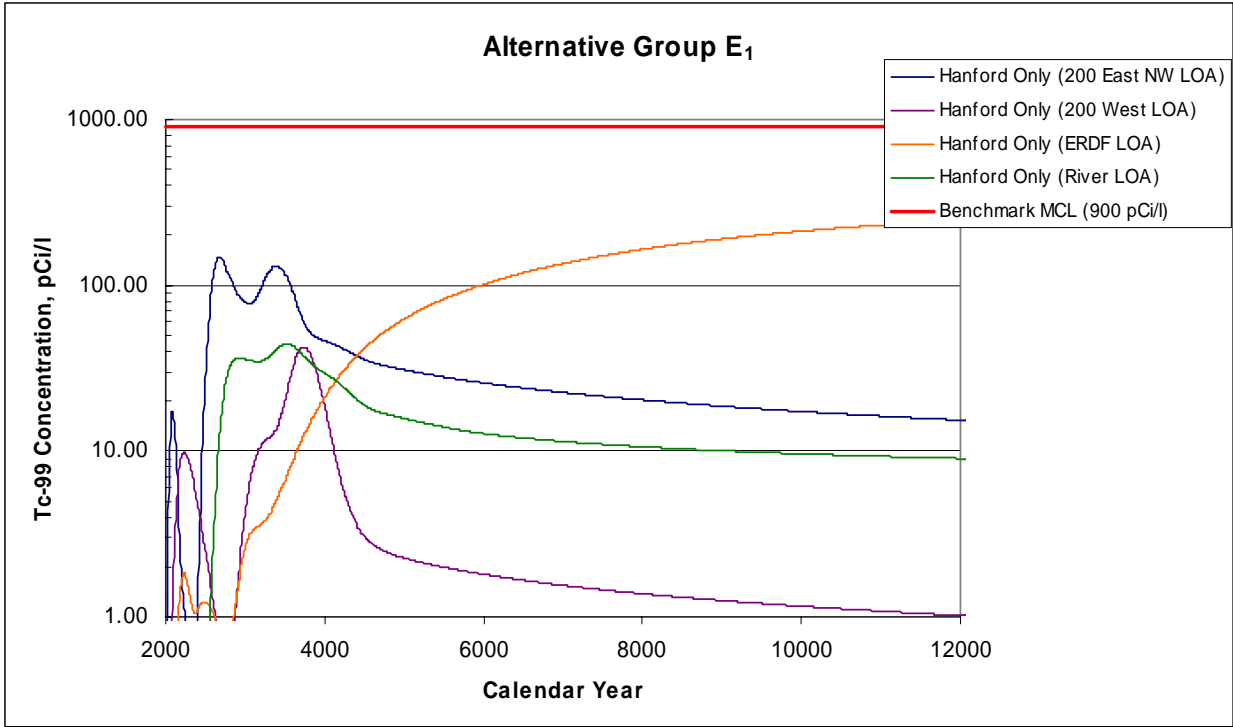




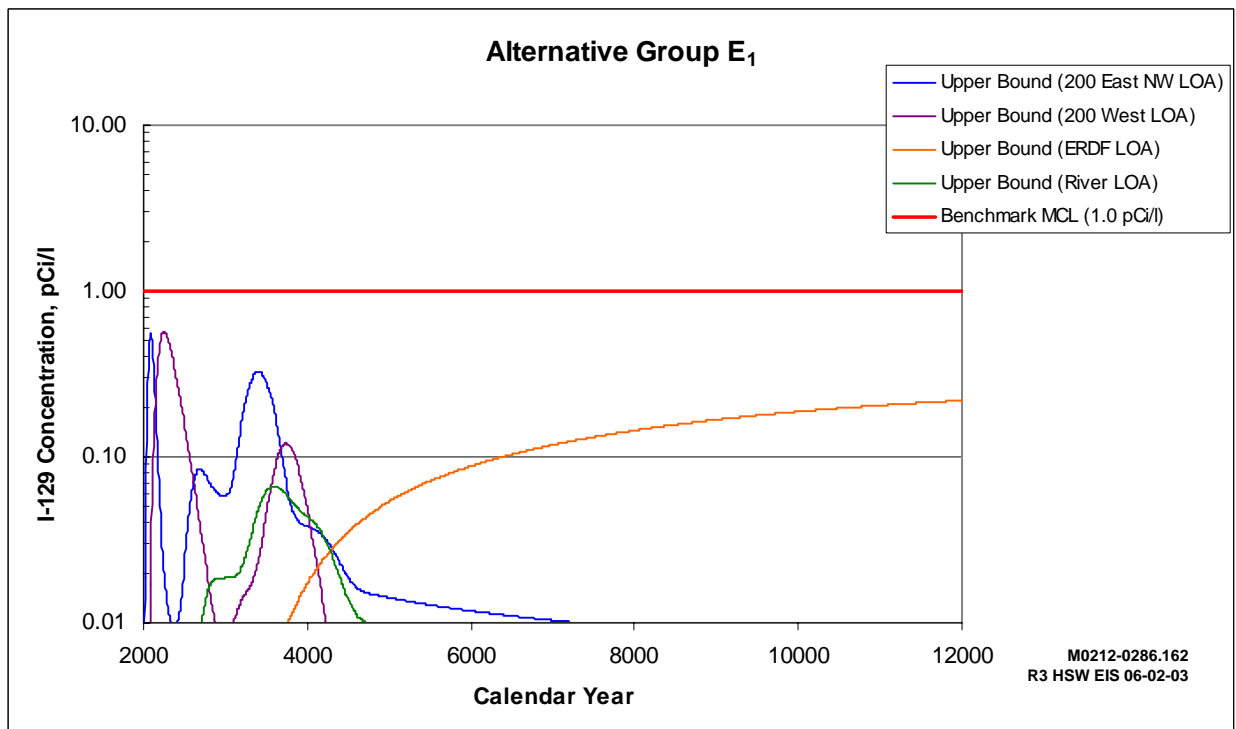
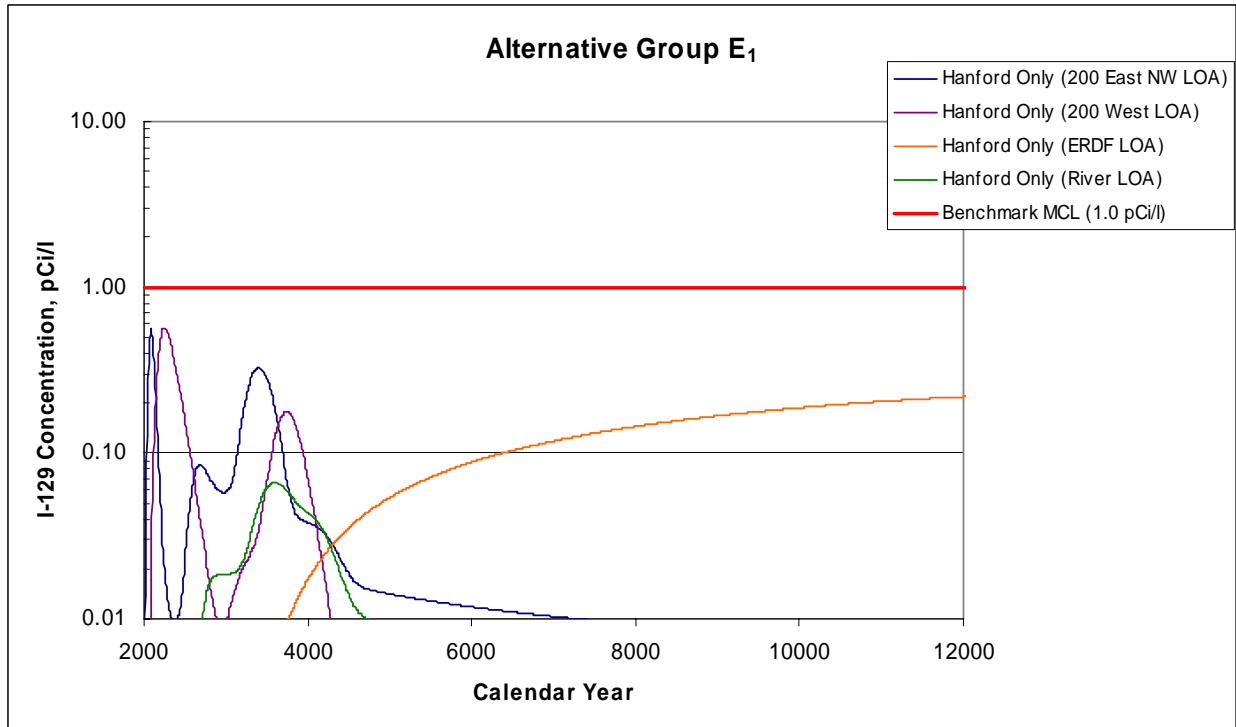
**Figure 5.13.** Technetium-99 Concentration Profiles at Various Lines of Analysis (Alternative Group D<sub>3</sub> – Hanford Only and Upper Bound Waste Volumes)



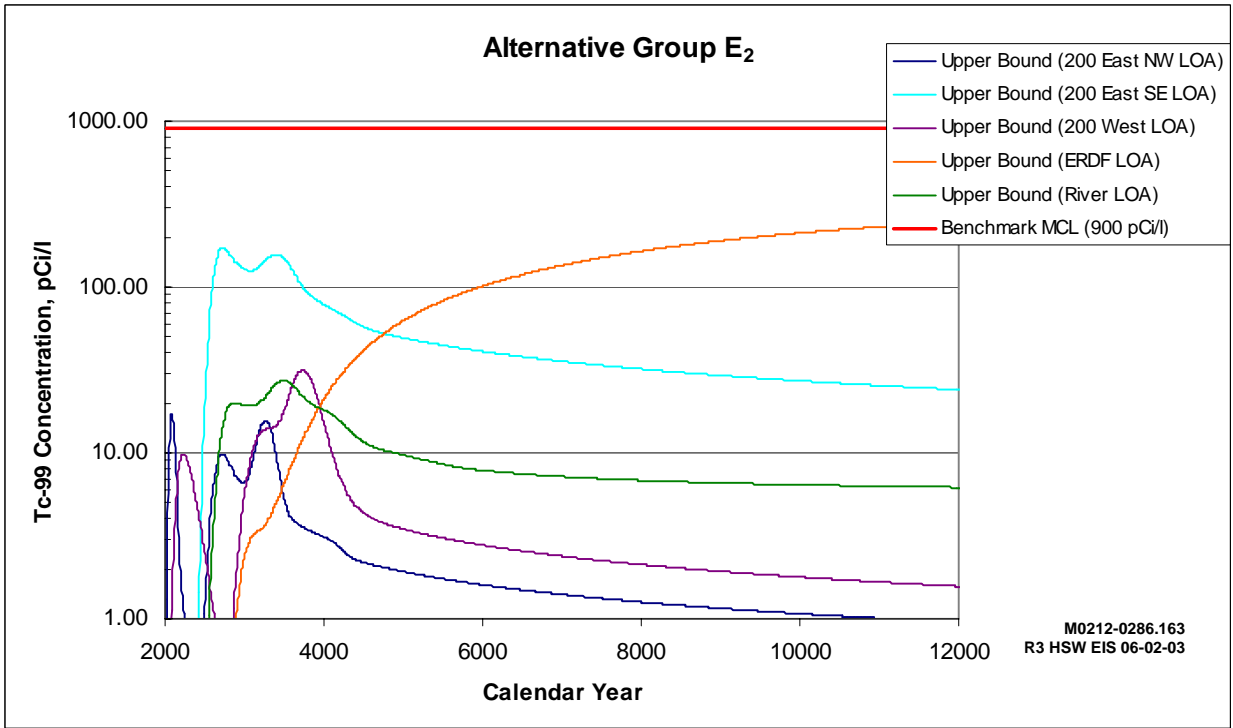
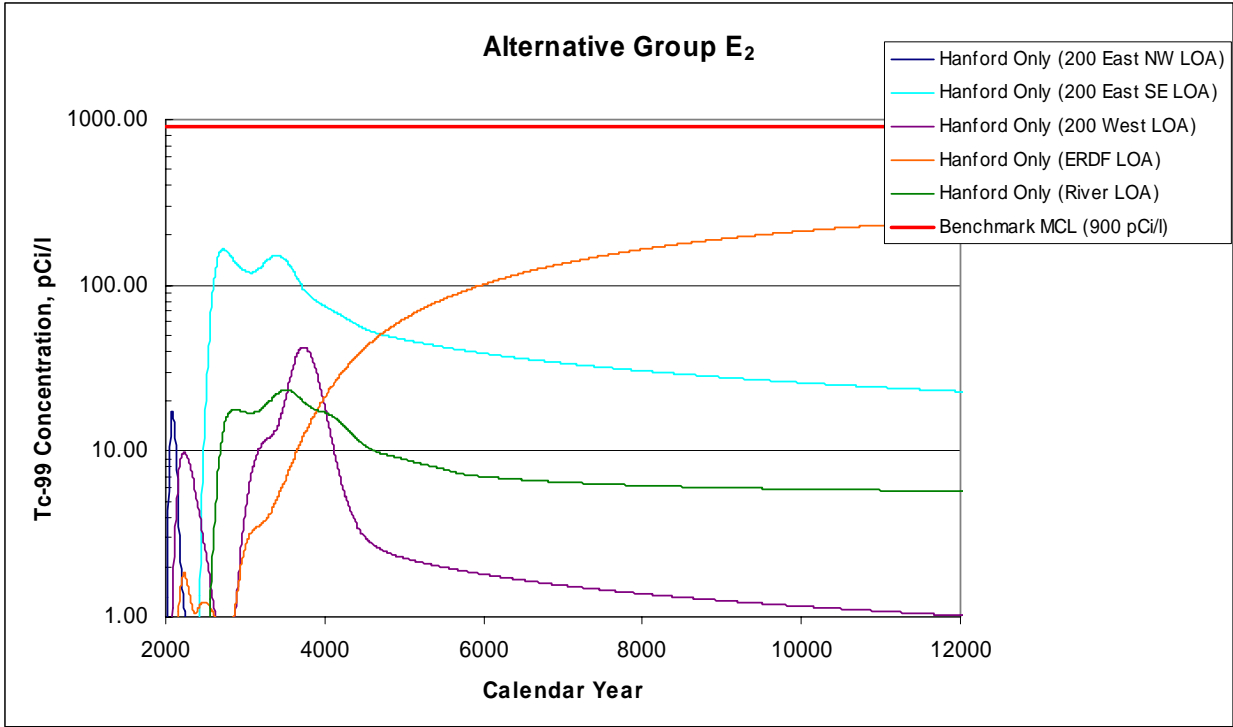
**Figure 5.14.** Iodine-129 Concentration Profiles at Various Lines of Analysis (Alternative Group D<sub>3</sub> – Hanford Only and Upper Bound Waste Volumes)



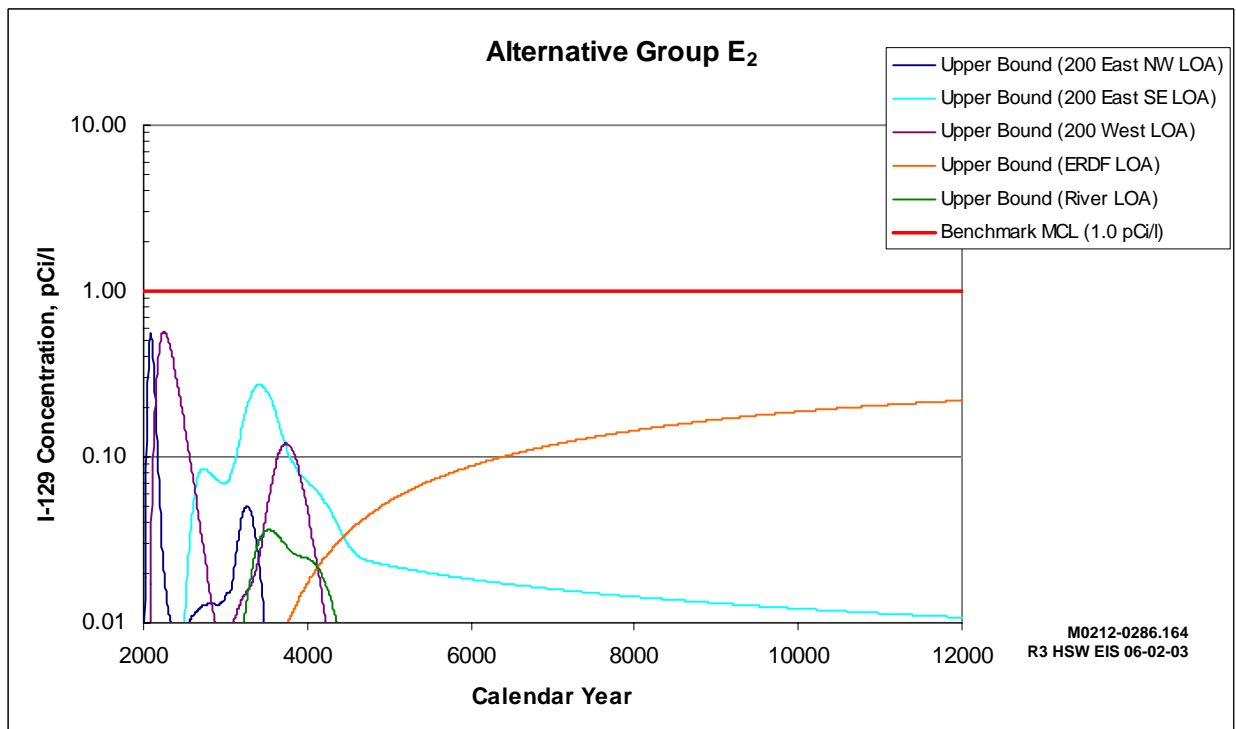
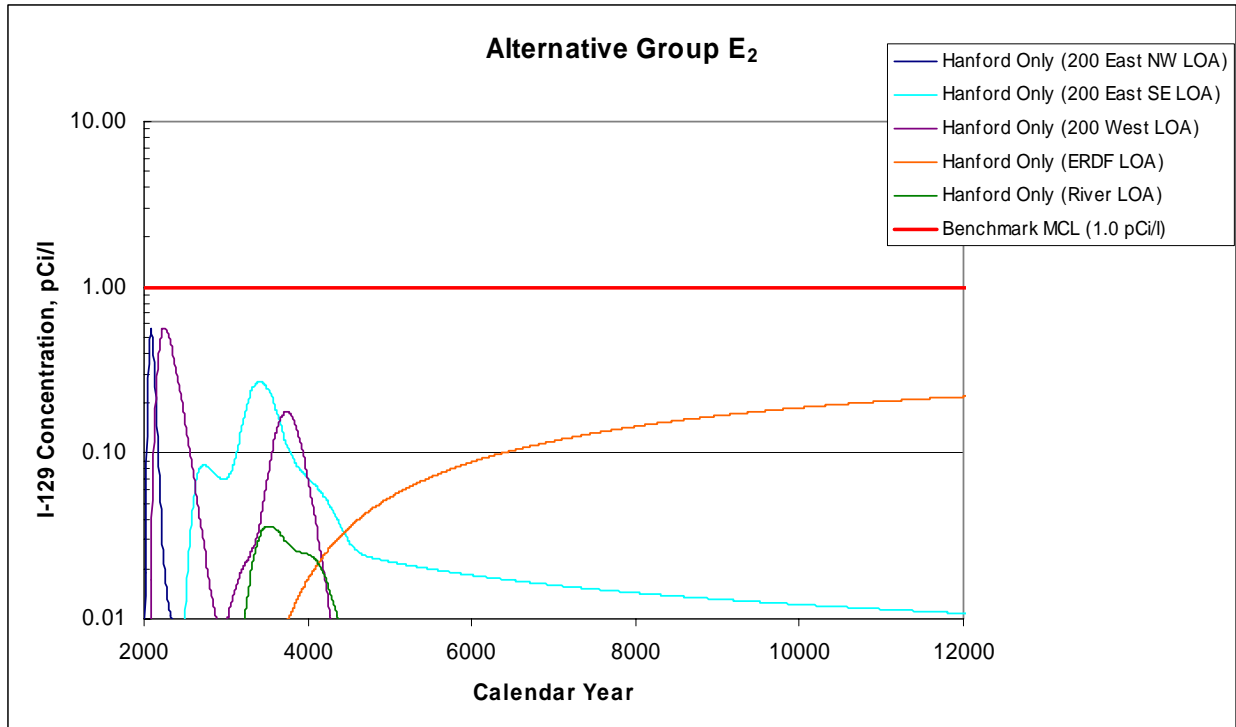
**Figure 5.15.** Technetium-99 Concentration Profiles at Various Lines of Analysis (Alternative Group E<sub>1</sub> – Hanford Only and Upper Bound Waste Volumes)



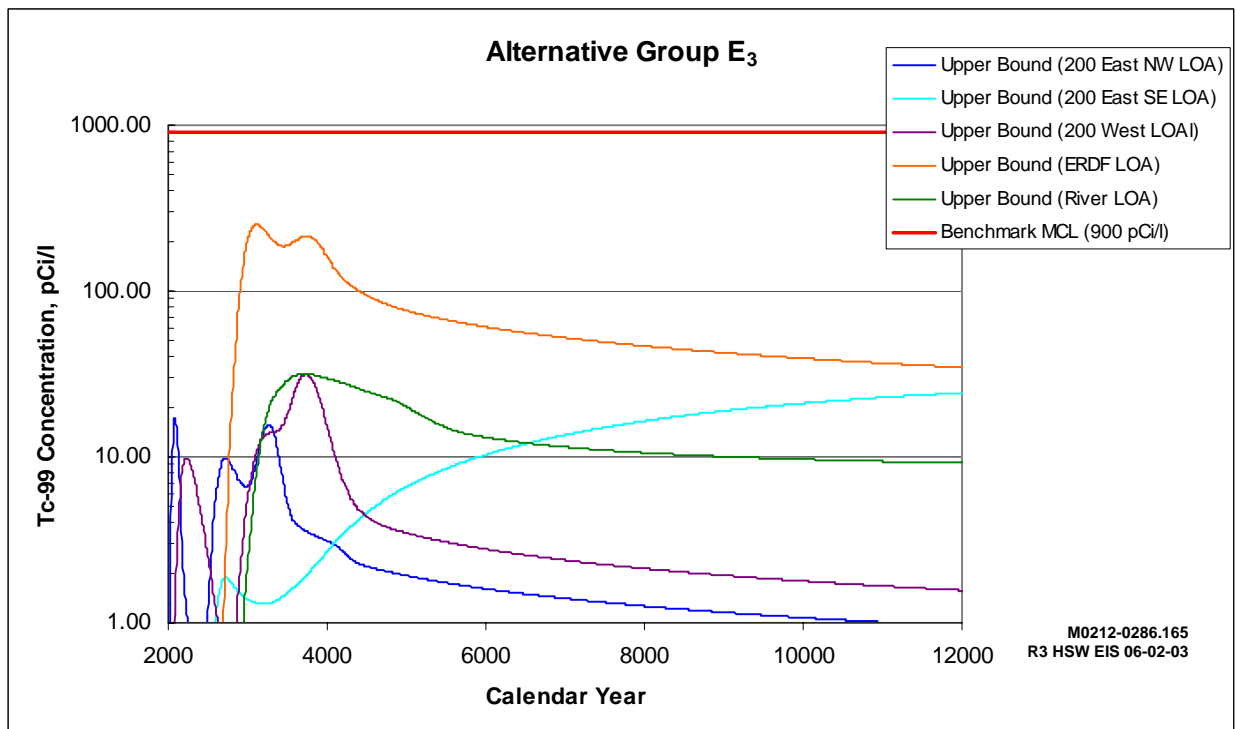
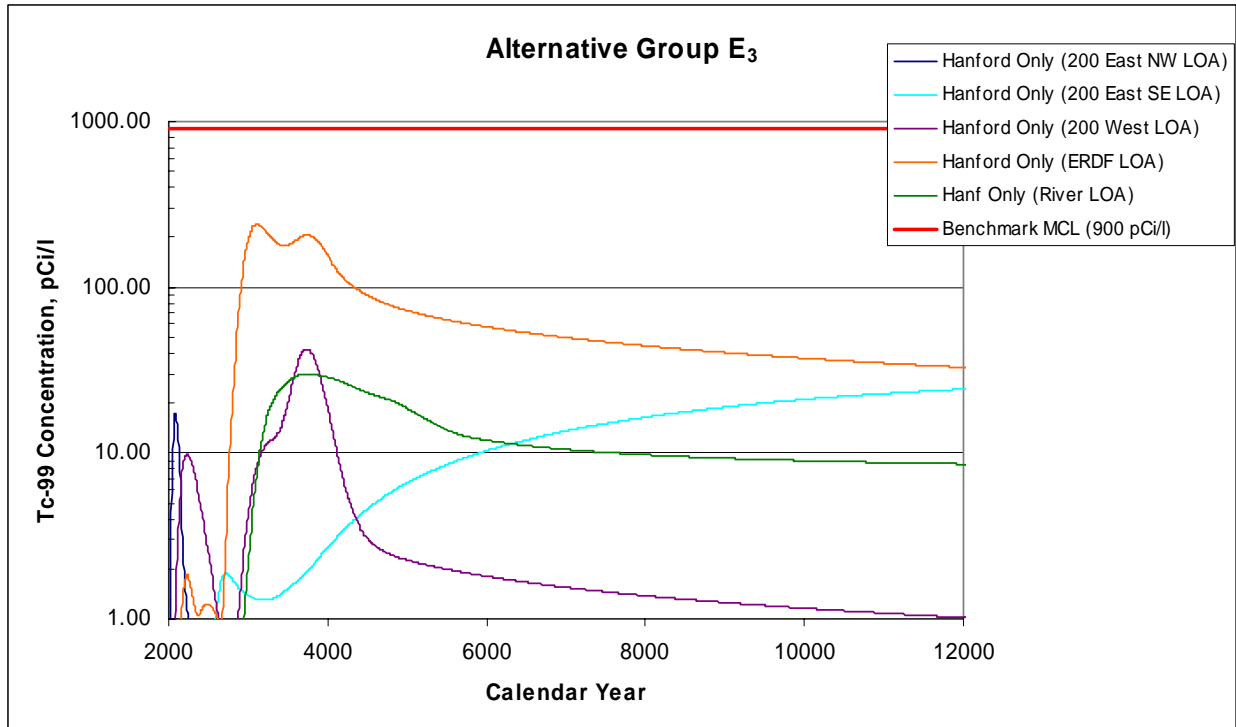
**Figure 5.16.** Iodine-129 Concentration Profiles at Various Lines of Analysis (Alternative Group E<sub>1</sub> – Hanford Only and Upper Bound Waste Volumes)



**Figure 5.17.** Technetium-99 Concentration Profiles at Various Lines of Analysis (Alternative Group E<sub>2</sub> – Hanford Only and Upper Bound Waste Volumes)

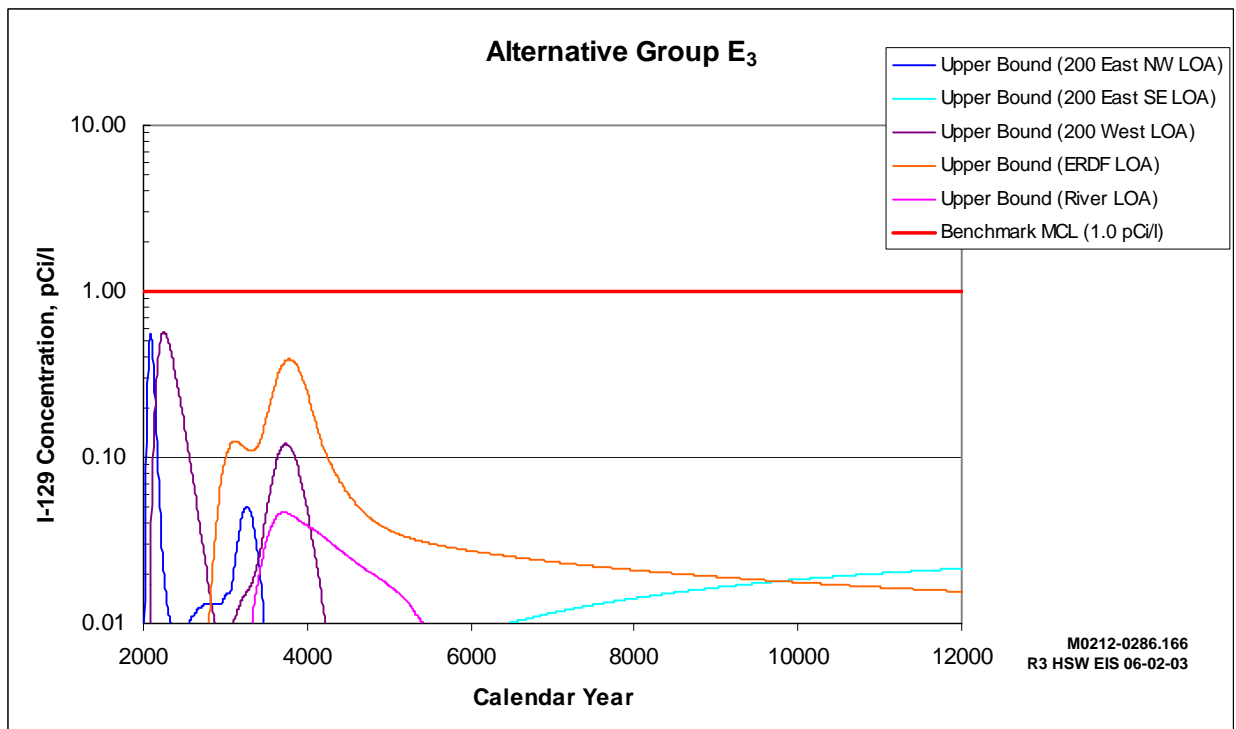
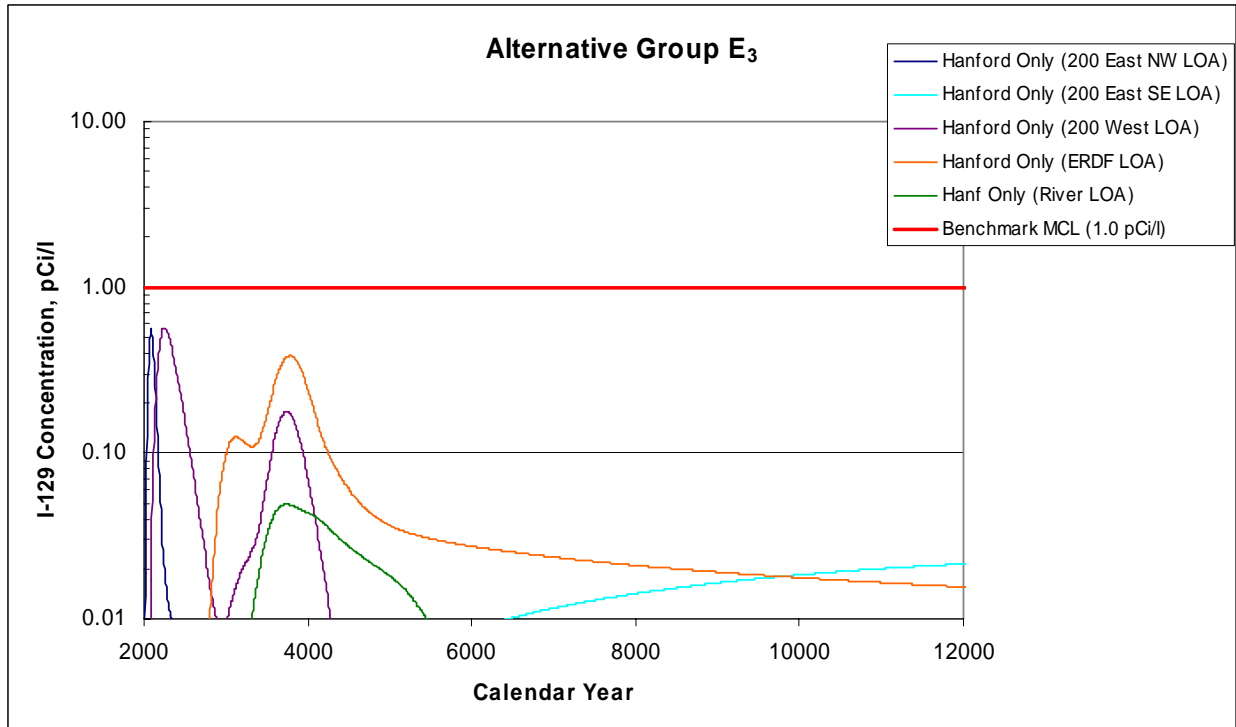


**Figure 5.18.** Iodine-129 Concentration Profiles at Various Lines of Analysis (Alternative Group E<sub>2</sub> – Hanford Only and Upper Bound Waste Volumes)



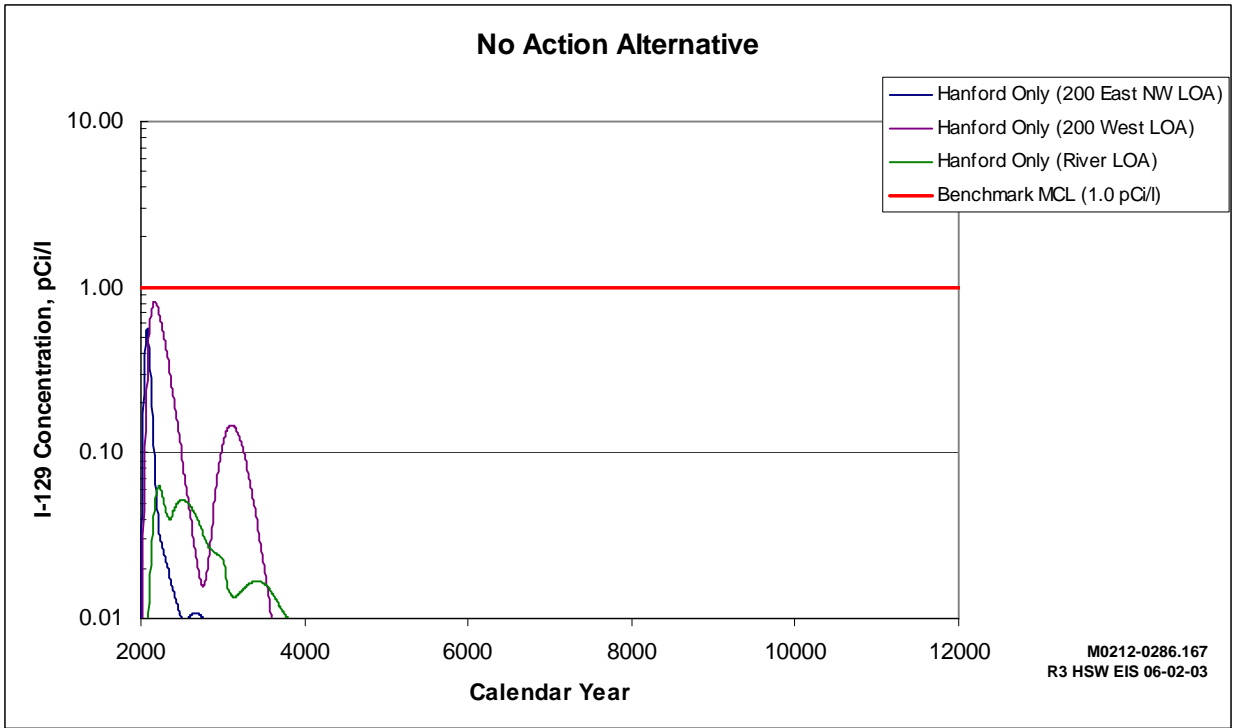
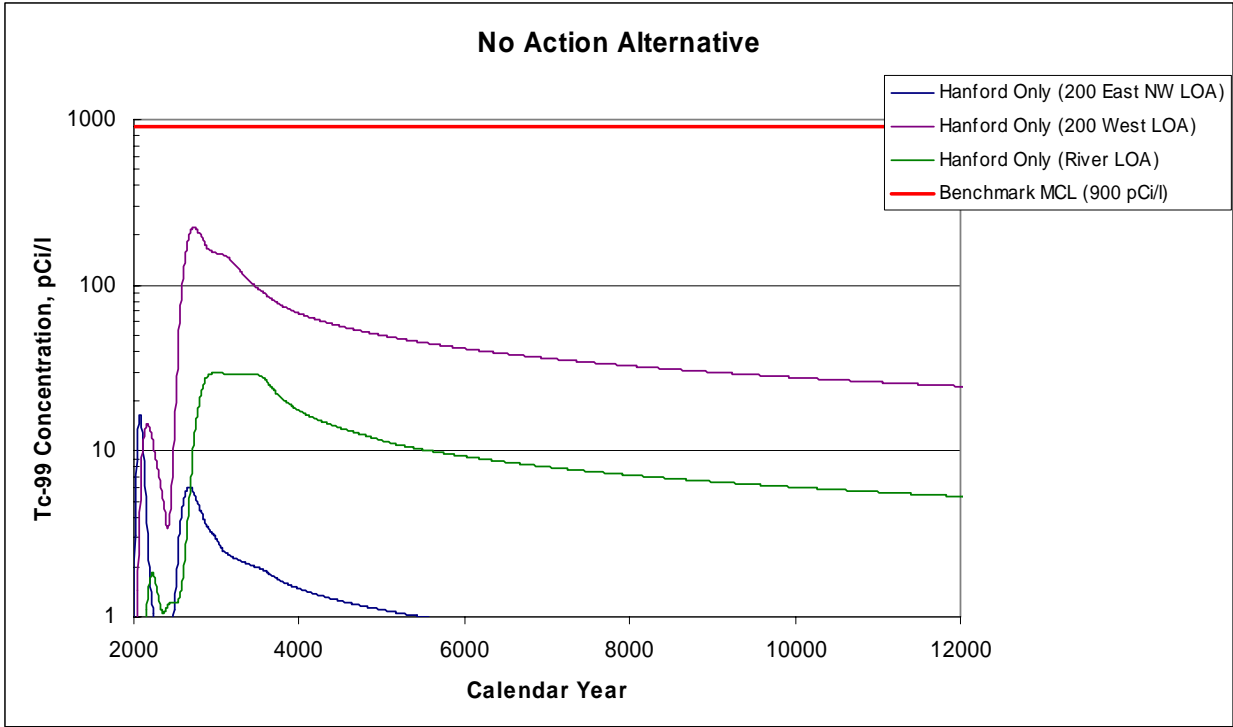
M0212-0286.165  
R3 HSW EIS 06-02-03

**Figure 5.19.** Technetium-99 Concentration Profiles at Various Lines of Analysis (Alternative Group E<sub>3</sub> – Hanford Only and Upper Bound Waste Volumes)



**Figure 5.20.** Iodine-129 Concentration Profiles at Various Lines of Analysis (Alternative Group E<sub>3</sub> – Hanford Only and Upper Bound Waste Volumes)





**Figure 5.21.** Technetium-99 and Iodine-129 Concentration Profiles at Various Lines of Analysis (No Action Alternative – Hanford Only Waste Volume)

#### **5.3.4.1 Alternative Group A**

LLW considered in Alternative Group A includes several different waste categories for disposal:

- pre-1970 LLW
- 1970–1987 LLW
- 1988–1995 LLW
- 1996–2007 Cat 1 and Cat 3 LLW and MLLW
- Cat 1 and Cat 3 LLW and MLLW disposed of after 2007 in deeper (18 m) (59 ft) and wider trenches in existing LLBGs 218-E-12B and 218-W-5
- melters disposed of after 2007 in a 21-m (69-ft) deep facility near the PUREX Plant
- ILAW disposed of after 2007 in a HSW disposal facility near the PUREX Plant.

Alternative Group A results for combined technetium-99 and iodine-129 concentration levels for the Hanford Only and Upper Bound waste volumes are summarized in Figures 5.3 and 5.4. These results show the potential impacts to groundwater quality at various lines of analysis starting in the year 2000. The potential impacts shown reflect: 1) early releases of technetium-99 and iodine-129 to groundwater from LLW disposed of prior to 1995 that peak in the next 100 to 200 years, 2) later releases of the same constituents from LLW and MLLW disposed of after 1996 that peak between the years 3000 and 4000, and 3) later increasing releases of technetium-99 and iodine-129 from ILAW disposal that peak at the end of the period of analysis (that is, the year 12,046 A.D.). Additional information can be found in several tables and figures in Volume II, Appendix G, Section G.2.1.

##### **5.3.4.1.1 Wastes Disposed of Before 1996**

Constituents released from wastes disposed of before 1996 in the LLBGs that have the highest potential impact on groundwater quality are technetium-99 and iodine-129. Estimated combined technetium-99 and iodine-129 levels at the 200 East Area NW LOA peaked at about 110 years after the assumed start of release and at about 220 years after the assumed start of release at the 200 West Area LOA. Combined concentration levels of technetium-99 were relatively low (less than 20 pCi/L) at these 1-km LOAs and reflect about 2 percent of the benchmark maximum contaminant level for technetium-99 (900 pCi/L). The combined concentration level of iodine-129 at the 200 East NW LOA was about 60 percent (0.6 pCi/L) of the benchmark MCL. This concentration level resulted from releases of the iodine-129 inventory in the 1970–1987 LLW. The combined concentration level of iodine-129 at the 200 West Area LOA was about 50 percent (0.5 pCi/L) of the benchmark MCL. This concentration level also resulted from releases of the iodine-129 inventory in the 1970–1987 LLW.

Technetium-99 and iodine-129 combined concentrations were well below benchmark MCLs by the time they reached the Columbia River. Overall concentration levels at the Columbia River LOA reached their peaks in about 260 years after the assumed start of release. Contaminant levels from sources in the 200 West Area reached their peaks along the Columbia River LOA between 500 and 600 years after the assumed start of release.

Carbon-14 and the uranium isotopes combined concentrations were found to peak at about or beyond the 10,000-year period of analysis. Carbon-14 concentrations at all LOAs were well below the benchmark MCL of 2000 pCi/L. Combined concentration levels of uranium-238, the dominant uranium isotope, also were well below the benchmark MCL at the 200 East and West Area LOAs at 10,000 years after site closure.

#### **5.3.4.1.2 Wastes Disposed of After 1995**

Potential groundwater quality impacts from wastes disposed of after 1995 also were highest for technetium-99 and iodine-129. Technetium-99 levels at the 200 East Area NW LOA were about 8 percent (75 pCi/L) of the benchmark MCL for the Hanford Only waste volume. The source for these elevated levels is from technetium-99 released from the MLLW disposed of after 2007. Technetium-99 levels at the 200 West Area LOA were about 33 percent (300 pCi/L) of the benchmark MCL. The source of these potential impacts was primarily from the technetium-99 released from the Cat 3 LLW disposed of after 2007. Predicted technetium-99 releases were very similar for all waste volumes but were slightly higher for the Upper Bound waste volume.

Combined iodine-129 levels at the 200 East Area NW LOA were about 30 percent of the benchmark MCL of 1 pCi/L for the Hanford Only waste volume. The main contributor to these concentration levels was the release of iodine-129 inventories in ungrouted parts of MLLW disposed of after 2007. Iodine-129 levels at the 200 West Area LOA were about 15 percent of the benchmark MCL of 1 pCi/L for the Hanford Only waste volume. The main contributor to these concentration levels was the release of iodine-129 inventories in ungrouted parts of MLLW disposed of between 1996 and 2007.

Combined iodine-129 levels were slightly higher at the 200 East Area NW LOA and slightly lower at the 200 West Area LOA for the Upper Bound waste volume. This result is reflective of changes in partitioning the iodine-129 inventory for the MLLW (1996–2007) waste category between the 200 East and West Areas for the Upper Bound inventory.

Combined technetium-99 and iodine-129 concentrations were well below benchmark MCLs by the time they reached the Columbia River. Overall concentration levels at the Columbia River LOA from sources in the 200 East Area reached their peaks between 1550 and 1600 years after site closure. Contaminant levels from sources in the 200 West Area reached their peaks near the river between 1600 and 2100 years after site closure.

Concentration levels of carbon-14 and the uranium isotopes at the LOAs did not reach their peak values until after the 10,000-year period of analysis and were well below benchmark MCLs at 10,000 years after site closure.

### **5.3.4.2 Alternative Group B**

LLW considered in Alternative Group B includes the same waste considered in Alternative Group A but disposes of Cat 1 and Cat 3 LLW and MLLW in conventional trenches after 2007 in LLBGs 218-E-12B and 218-W-5 and in the ILAW disposal facility located just south of the CWC.

Alternative Group B results for combined technetium-99 and iodine-129 concentration levels for the Hanford Only and Upper Bound waste volumes are summarized in Figures 5.5 and 5.6. As in Alternative Group A, these results show the potential impacts to groundwater quality at various lines of analysis from: 1) early releases of technetium-99 and iodine-129 to groundwater from LLW disposed of prior to 1995 that peak in the next 100 to 200 years, 2) later releases of the same constituents from LLW and MLLW disposed of after 1996 that peak between the years 3000 and 4000, and 3) later increasing releases of technetium-99 and iodine-129 from ILAW disposal that peak at the end of the period of analysis (that is, the year 12,046 A.D.). Additional information is found in several tables and figures in Volume II, Appendix G, Volume II.

#### **5.3.4.2.1 Wastes Disposed of Before 1996**

Potential impacts from wastes disposed of before 1996 were the same for all alternative groups. This discussion is presented under results for Alternative Group A (see Section 5.3.4.1.1).

#### **5.3.4.2.2 Wastes Disposed of After 1995**

Under this alternative group, groundwater quality was most impacted by releases of technetium-99 and iodine-129 from disposed LLW and MLLW. Technetium-99 levels at the 200 East Area NW LOA were about 11 and 13 percent of the benchmark MCLs (95 and 116 pCi/L) for the Hanford Only and Upper Bound waste volumes, respectively. The primary source for these elevated levels was from inventories in MLLW disposed of after 2007. These higher concentration levels are generally consistent with the broader surface area of releases associated with the use of conventional trenches under this alternative group.

Combined technetium-99 levels at the 200 West Area LOA were estimated to be about 33 percent (300 pCi/L) of the benchmark MCL of 900 pCi/L for the Hanford Only and Upper Bound waste volumes. These values are slightly less than levels estimated for Alternative Group A. However, this would be expected since the source of these potential impacts was primarily from the technetium-99 inventories in the Cat 3 LLW disposed of after 2007. Additionally, the use of conventional trenches under this alternative group would result in some of the inventory associated with Cat 1 and Cat 3 LLW disposed of after 2007 being emplaced in the 200 East Area.

Combined iodine-129 levels at the 200 East Area NW LOA were 42 and 47 percent (0.42 and 0.47 pCi/L) of the benchmark MCL of 1 pCi/L for the Hanford Only and Upper Bound waste volumes, respectively. The main contributor to these concentration levels was the release of iodine-129 inventories in ungrouted parts of the MLLW disposed of after 2007. Iodine-129 levels at the 200 West Area LOA were less than 8 percent (0.08 pCi/L) of the benchmark MCL for the Hanford Only waste volume. The

main contributor to these concentration levels was from iodine-129 inventories in the ungrouted part of the MLLW disposed of between 1996 and 2007.

Combined iodine-129 levels were slightly higher at the 200 East Area NW LOA and slightly lower at the 200 West Area LOA for the Upper Bound waste volume. This impact is reflective of changes in partitioning the iodine-129 inventory for the MLLW (1996–2007) waste category between the 200 East and West Areas for the Upper Bound waste volume.

Concentration levels of carbon-14 and the uranium isotopes at the LOAs downgradient from source areas of projected LLW and MLLW did not reach their peak values until after the 10,000-year period of analysis. Concentration levels for both constituents were well below benchmark MCLs at 10,000 years after site closure.

Concentrations of all constituents were well below benchmark MCLs by the time they reached the Columbia River LOA. Overall concentration levels at the Columbia River LOA from sources in the 200 East Area reached their peaks at about 1400 years after site closure. Contaminant levels from sources in the 200 West Area sources reached their peaks near the river at about 1500 years after site closure.

#### **5.3.4.3 Alternative Group C**

LLW considered in Alternative Group C includes the same wastes considered in Alternative Group A but disposes of Cat 1 and Cat 3 LLW in a single, lined expandable trench and MLLW in another single, lined expandable trench after 2007 in LLBGs 218-E-12B and 218-W-5. The melters would be placed in a lined trench and ILAW would be placed in a single, expandable, lined trench near the PUREX Plant.

Alternative Group C results for combined technetium-99 and iodine-129 concentration levels for the Hanford Only and Upper Bound waste volumes are summarized in Figures 5.7 and 5.8. As in Alternative Groups A and B, these results show the potential impacts to groundwater quality at various lines of analysis from: 1) early releases of technetium-99 and iodine-129 to groundwater from LLW disposed of prior to 1995 that peak in the next 100 to 200 years, 2) later releases of the same constituents from LLW and MLLW disposed of after 1996 that peak between the years 3000 and 4000, and 3) later increasing releases of technetium-99 and iodine-129 from ILAW disposal that peak at the end of the period of analysis (that is, the year 12,046 A.D.). Additional information is provided in several tables and figures in Volume II, Appendix G, Section G.2.3.

##### **5.3.4.3.1 Wastes Disposed of Before 1996**

Potential impacts from wastes disposed of before 1996 were the same for all alternative groups. This discussion is presented under results for Alternative Group A (see Section 5.3.4.1.1).

#### **5.3.4.3.2 Wastes Disposed of After 1995**

Because of assumptions in the source-term release and vadose zone modeling used for previously buried LLW and LLW and MLLW disposed of between 1996 and 2007 for Alternative Group C, results for this alternative group were the same for those waste categories calculated for Alternative Group A. Results for LLW and MLLW disposed of after 2007 for this alternative group were essentially the same as those presented in the figures for Alternative Group A. These results are consistent since the analysis assumption about waste depth and projected land use for waste disposed of after 2007 are the same for both alternative groups.

#### **5.3.4.4 Alternative Group D<sub>1</sub>**

Wastes considered in Alternative Group D<sub>1</sub> are the same as those described for Alternative Group A. However, in this alternative group, all wastes received after 2007 would be disposed of in a single, lined, modular combined-use facility near the PUREX Plant.

Alternative Group D<sub>1</sub> results for combined technetium-99 and iodine-129 concentration levels for the Hanford Only and Upper Bound waste volumes are summarized in Figures 5.9 and 5.10. As was provided in the previous alternatives groups, these results show the potential impacts to groundwater quality at various lines of analysis from: 1) early releases of technetium-99 and iodine-129 to groundwater from LLW disposed of prior to 1995 that peak in the next 100 to 200 years, 2) later releases of the same constituents from LLW and MLLW disposed of after 1996 that peak between the years 3000 and 4000, and 3) later increasing releases of technetium-99 and iodine-129 from ILAW disposal that peak at the end of the period of analysis (that is, the year 12,046 A.D.). Additional information can be found in several tables and figures in Volume II, Appendix G, Section G.2.4.

#### **5.3.4.4.1 Wastes Disposed of Before 1996**

Potential impacts from wastes disposed of before 1996 were the same for all alternative groups. This discussion is presented under results for Alternative Group A (see Section 5.3.4.1.1).

#### **5.3.4.4.2 Wastes Disposed of After 1995**

The highest potential impacts for this alternative group reflect the emplacement of all wastes disposed of after 2007 in the vicinity of the PUREX Plant. Potential impacts from LLW and MLLW are dominated by technetium-99 and iodine-129.

Combined concentration levels for technetium-99 were about 18 and 20 percent (167 and 185 pCi/L) of the benchmark MCL at the 200 East SE LOA for the Hanford Only and Upper Bound waste volumes, respectively. The primary source for these elevated levels was from inventories in MLLW disposed of after 2007. Two peaks reflect technetium-99 inventories in both Cat 3 LLW and MLLW disposed of after 2007 near the PUREX area.

Combined technetium-99 concentration levels at the 200 West Area LOA were about 5 and 3 percent (42 and 31 pCi/L) of the benchmark MCL for the Hanford Only and Upper Bound waste volumes, respectively. These values are slightly less than levels estimated for Alternative Group A. The source of these potential impacts was primarily from the technetium-99 inventory in MLLW disposed of between 1996 and 2007. Decreased concentrations for the Upper Bound waste volume reflect the emplacement of some of the MLLW inventory in the 200 East Area.

Combined iodine-129 concentration levels at the 200 East SE LOA were about 28 percent (0.28 pCi/L) of the benchmark MCL for the Hanford Only and Upper Bound waste volumes. The main contributor to these concentration levels was iodine-129 inventories in ungrouted parts of the MLLW disposed of after 2007.

Combined iodine-129 levels at the 200 West Area LOA were about 15 and 8 percent (0.15 and 0.08 pCi/L) of the benchmark MCL for the for the Hanford Only and Upper Bound waste volumes, respectively. The main contributor to these concentration levels was from ungrouted iodine-129 inventories in MLLW disposed of between 1996 and 2007.

Combined iodine-129 levels were slightly higher at the 200 East Area SE LOA and slightly lower at the 200 West Area LOA for the Upper Bound waste volume. These results are reflective of changes in partitioning of iodine-129 inventory for the MLLW (1996–2007) waste category between the 200 East and West Areas for the Upper Bound waste volume.

Combined concentration levels of carbon-14 and the uranium isotopes at the 200 East and West Area LOAs from source areas of projected LLW and MLLW did not reach their peak values until after the 10,000-year period of analysis. Concentration levels for both constituents were well below the benchmark MCLs at 10,000 years after site closure.

Combined technetium-99 and iodine-129 concentrations were well below benchmark MCLs by the time they reached the Columbia River. Overall concentration levels at the Columbia River LOA from sources in the 200 East Area reached their peaks near the river between 1400 and 1500 years after site closure. Contaminant levels at the same LOA from sources in the 200 West Area reached their peaks between 2100 and 2200 years after site closure.

#### **5.3.4.5 Alternative Group D<sub>2</sub>**

Wastes considered in Alternative Group D<sub>2</sub> are the same as those described for Alternative Group A. However, in this alternative group, all wastes received after 2007 would be disposed of in a single, lined, modular combined-use facility in LLBG 218-E-12B.

Alternative Group D<sub>2</sub> results for combined technetium-99 and iodine-129 concentration levels for the Hanford Only and Upper Bound waste volumes are summarized in Figures 5.11 and 5.12. As was provided in the previous alternative groups, these results show the potential impacts to groundwater quality at various lines of analysis from: 1) early releases of technetium-99 and iodine-129 to groundwater from LLW disposed of prior to 1995 that peak in the next 100 to 200 years, 2) later releases of the same

constituents from LLW and MLLW disposed of after 1996 that peak between the years 3000 and 4000, and 3) later increasing releases of technetium-99 and iodine-129 from ILAW disposal that peak at the end of the period of analysis (that is, the year 12,046 A.D.). Additional information can be found in several tables and figures in Volume II, Appendix G, Section G.2.5.

#### **5.3.4.5.1 Wastes Disposed of Before 1996**

Potential impacts from wastes disposed of before 1996 were the same for all alternative groups. This discussion is presented under results for Alternative Group A (see Section 5.3.4.1.1).

#### **5.3.4.5.2 Wastes Disposed of After 1995**

The highest potential impacts for this alternative group reflect emplacement of LLW and MLLW disposed of after 2007 in the 218-E-12B LLBG. These potential impacts were primarily from technetium-99 and iodine-129.

Combined technetium-99 levels at the 200 East Area NW LOA were about 16 and 19 percent (148 and 169 pCi/L) of the benchmark MCL for the Hanford Only and Upper Bound waste volumes, respectively. The primary source for these elevated levels was from inventories in Cat 3 LLW and MLLW disposed of after 2007.

Combined concentration levels of technetium-99 at the 200 West Area LOA were about 5 and 3 percent (42 and 31 pCi/L) of the benchmark MCL for the Hanford Only and Upper Bound waste volumes, respectively. These values are slightly less than levels estimated for Alternative Group A. The source of these potential impacts was primarily from the technetium-99 inventory in MLLW disposed of between 1996 and 2007. Decreased concentrations for the Upper Bound waste volume reflect the emplacement of some of the MLLW inventory in the 200 East Area.

The highest combined iodine-129 levels at the 200 East Area NW LOAs were about 28 percent (0.28 pCi/L) of the benchmark MCL for both the Hanford Only and Upper Bound waste volumes. The main contributor to these concentration levels was ungrouted iodine-129 inventories in MLLW disposed of after 2007.

The highest combined iodine-129 levels were about 15 and 8 percent (0.15 and 0.08 pCi/L) of the benchmark MCL at the 200 West Area LOA for the Hanford Only and Upper Bound waste volumes, respectively. The main contributor to these concentration levels was ungrouted iodine-129 inventories in MLLW disposed of between 1996 and 2007.

The highest combined iodine-129 levels were slightly higher at the 200 East Area NW LOA and slightly lower at the 200 West Area LOA for the Upper Bound waste volume. This is reflective of changes in partitioning of the iodine-129 inventory for the MLLW (1996–2007) waste category between the 200 East and West Areas for the Upper Bound waste volume.



Concentration levels of carbon-14 and the uranium isotopes at all LOAs did not reach their peak values until after the 10,000-year period of analysis. Concentration levels for both constituents were well below the benchmark MCLs at 10,000 years after site closure.

Combined technetium-99 and iodine-129 concentrations were well below the benchmark MCLs by the time they reached the Columbia River. Overall concentration levels at the Columbia River LOA from sources in the 200 East Area reached their peaks between 1500 and 1600 years after site closure. Contaminant levels from sources in the 200 West Area reached their peaks near the river at about 2000 years after site closure.

#### **5.3.4.6 Alternative Group D<sub>3</sub>**

Wastes considered in Alternative Group D<sub>3</sub> are the same as those described for Alternative Group A. However, in this alternative group, all wastes received after 2007 would be disposed of in a single, lined, modular combined-use facility at ERDF.

Alternative Group D<sub>3</sub> results for combined technetium-99 and iodine-129 concentration levels for the Hanford Only and Upper Bound waste volumes are summarized in Figures 5.13 and 5.14. As was provided in the previous alternative groups, these results show the potential impacts to groundwater quality at various lines of analysis from: 1) early releases of technetium-99 and iodine-129 to groundwater from LLW disposed of prior to 1995 that peak in the next 100 to 200 years, 2) later releases of the same constituents from LLW and MLLW disposed of after 1996 that peak between the years 3000 and 4000, and 3) later increasing releases of technetium-99 and iodine-129 from ILAW disposal that peak at the end of the period of analysis (that is, the year 12,046 A.D.). Additional information can be found in several tables and figures in Volume II, Appendix G, Section G.2.6.

##### **5.3.4.6.1 Wastes Disposed of Before 1996**

Potential impacts from wastes disposed of before 1996 were the same for all alternative groups. This discussion is presented under results for Alternative Group A (see Section 5.3.4.1.1).

##### **5.3.4.6.2 Wastes Disposed of After 1995**

The highest potential groundwater quality impacts for this alternative group reflect emplacement of LLW and MLLW disposed of after 2007 at ERDF. Potential impacts were primarily from technetium-99 and iodine-129.

No LLW and MLLW were disposed of after 1996 in the 200 East Area for the Hanford Only waste volume under this alternative group. Combined technetium-99 levels at the 200 East Area NW LOA were about 2 percent (15.7 pCi/L) of the benchmark MCL for the Upper Bound waste volume. The primary source for these elevated levels was from inventories in MLLW disposed of between 1996 and 2007.

Combined technetium-99 levels at the 200 West Area LOA were about 5 and 3 percent (42 and 31 pCi/L) of the benchmark MCL for the Hanford Only and Upper Bound waste volumes, respectively. These values are slightly less than levels estimated for Alternative Group A. The source of these potential impacts was primarily from the technetium-99 inventory in MLLW disposed of between 1996 and 2007. Decreased concentrations for the Upper Bound waste volume reflect the emplacement of some of the MLLW inventory in the 200 East Area.

Combined technetium-99 levels at the ERDF LOA were about 27 and 28 percent (242 and 253 pCi/L) of the benchmark MCL for the Hanford Only and Upper Bound waste volumes, respectively. The primary source for these elevated levels was from inventories in the Cat 3 LLW disposed of after 2007.

No LLW and MLLW were disposed of after 1996 in the 200 East Area for the Hanford Only waste volume under this alternative group. Combined iodine-129 levels at the 200 East Area NW LOA were about 5 percent (0.05 pCi/L) of the benchmark MCL for the Upper Bound waste volume. The main contributor to these concentration levels was from ungrouted iodine-129 inventories in MLLW disposed of between 1996 and 2007.

Combined iodine-129 levels at the 200 West Area LOA were about 15 and 8 percent (0.15 and 0.08 pCi/L) of the benchmark MCL for the Hanford Only and Upper Bound waste volumes, respectively. The main contributor to these concentration levels was from ungrouted iodine-129 inventories in MLLW disposed of between 1996 and 2007.

Combined iodine-129 levels at the 200 West Area LOA were slightly higher at the 200 East Area NW LOA and slightly lower for the Upper Bound waste volume. This result reflects assumed changes in partitioning of the iodine-129 inventory for the MLLW (1996–2007) waste category between the 200 East and West Areas for the Upper Bound inventory.

Combined iodine-129 levels at the ERDF LOA were 92 and 94 percent (0.92 and 0.94 pCi/L) of the benchmark MCL for the Hanford Only waste volume. The main contributor to these concentration levels was from ungrouted iodine-129 inventories in MLLW disposed of after 2007.

Concentration levels of carbon-14 and the uranium isotopes at all LOAs downgradient from source areas of projected LLW and MLLW did not reach their peak values until after the 10,000-year period of analysis. Concentration levels for both constituents were well below benchmark MCLs at 10,000 years after site closure.

Combined technetium-99 and iodine-129 concentrations were well below benchmark MCLs by the time they reached the Columbia River. Overall concentration levels from sources in the 200 East Area reached their peaks near the river at about 1400 years after site closure. Contaminant levels from sources in the 200 West Area reached their peaks near the river at about 2000 years after site closure.

#### **5.3.4.7 Alternative Group E<sub>1</sub>**

Alternative Group E<sub>1</sub> results for combined technetium-99 and iodine-129 concentration levels for the Hanford Only and Upper Bound waste volumes are summarized in Figures 5.15 and 5.16. As was provided in the previous alternative groups, these results show the potential impacts to groundwater quality at various lines of analysis from: 1) early releases of technetium-99 and iodine-129 to groundwater from LLW disposed of prior to 1995 that peak in the next 100 to 200 years, 2) later releases of the same constituents from LLW and MLLW disposed of after 1996 that peak between the years 3000 and 4000, and 3) later increasing releases of technetium-99 and iodine-129 from ILAW disposal that peak at the end of the period of analysis (that is, the year 12,046 A.D.). Additional information can be found in several tables and figures in Volume II, Appendix G, Section G.2.7.

##### **5.3.4.7.1 Wastes Disposed of Before 1996**

Potential impacts from wastes disposed of before 1996 were the same for all alternative groups. This discussion is presented under results for Alternative Group A (see Section 5.3.4.1.1).

##### **5.3.4.7.2 Wastes Disposed of After 1995**

Potential impacts for this alternative group reflect emplacement of LLW and MLLW disposed of after 2007 in LLBG 218-E-12B and disposal of melters and ILAW at ERDF. Results for LLW and MLLW disposed of after 2007 are identical to results for the same wastes in Alternative D<sub>2</sub>. The highest potential impacts resulted from releases of technetium-99 and iodine-129.

Combined technetium-99 levels at the 200 East Area NW LOA were about 16 and 19 percent (148 and 169 pCi/L) of the benchmark MCL for the Hanford Only and Upper Bound waste volumes. The primary source for these elevated levels was from inventories in Cat 3 LLW and MLLW disposed of after 2007.

Combined technetium-99 levels at the 200 West Area LOA were about 5 and 3 percent (42 and 31 pCi/L) of the benchmark MCL for the Hanford Only and Upper Bound waste volumes, respectively. These values are slightly less than levels estimated for Alternative Group A. The source of these potential impacts was primarily from the technetium-99 inventory in MLLW disposed of between 1996 and 2007. Decreased concentrations for the Upper Bound waste volume reflect the emplacement of some of the MLLW inventory in the 200 East Area.

Combined technetium-99 levels at the ERDF LOA were about 0.3 percent (2.7 pCi/L) of the benchmark MCL for both the Hanford Only and Upper Bound waste volumes. The primary source for these elevated levels was from inventories in the melters disposed of after 2007.

No LLW and MLLW were disposed of after 1996 in the 200 East Area for the Hanford Only waste volume under this alternative group. Combined iodine-129 levels at the 200 East Area NW LOA were

about 5 percent (0.04 pCi/L) of the benchmark MCL for the Upper Bound waste volume. The main contributor to these concentration levels was from ungrouted iodine-129 inventories in MLLW disposed of between 1996 and 2007.

Combined iodine-129 levels at the 200 West Area LOA were 15 and 8 percent (0.15 and 0.08 pCi/L) of the benchmark MCL for the Hanford Only and Upper Bound waste volumes, respectively. The main contributor to these concentration levels was from ungrouted iodine-129 inventories in MLLW disposed of between 1996 and 2007.

Combined iodine-129 levels at the 200 West Area LOA were slightly higher at the 200 East Area NW LOA and slightly lower for the Upper Bound waste volume, which is reflective of changes in partitioning of the iodine-129 inventory for the MLLW (1996–2007) waste category between the 200 East and West Areas for the Upper Bound inventory.

Combined iodine-129 levels were 22 percent (0.22 pCi/L) at the ERDF LOA for both the Hanford Only and Upper Bound waste volumes. No iodine-129 inventory was estimated for melters disposed of at ERDF after 2007 for this alternative group.

Concentration levels of carbon-14 and the uranium isotopes at the LOA downgradient from source areas of projected LLW and MLLW did not reach their peak values until after the 10,000-year period of analysis. Concentration levels for both constituents were well below benchmark MCLs at 10,000 years after site closure.

Combined technetium-99 and iodine-129 concentrations were well below benchmark MCLs by the time they reached the Columbia River. Overall concentration levels at the Columbia River LOA from sources in the 200 East Area reached their peaks near the river at about 1400 years after site closure. Contaminant levels from sources in the 200 West Area reached their peaks near the river at about 2000 years after site closure.

#### **5.3.4.8 Alternative Group E<sub>2</sub>**

Results for Alternative Group E<sub>2</sub> for combined technetium-99 and iodine-129 concentration levels for Hanford Only and Upper Bound waste volumes are summarized in Figures 5.17 and 5.18. As was provided in the previous alternative groups, these results show the potential impacts to groundwater quality at various lines of analysis from: 1) early releases of technetium-99 and iodine-129 to groundwater from LLW disposed of prior to 1995 that peak in the next 100 to 200 years, 2) later releases of the same constituents from LLW and MLLW disposed of after 1996 that peak between the years 3000 and 4000, and 3) later increasing releases of technetium-99 and iodine-129 from ILAW disposal that peak at the end of the period of analysis (that is, the year 12,046 A.D.). Additional information can be found in several tables and figures in Volume II, Appendix G, Section G.2.8.

##### **5.3.4.8.1 Wastes Disposed of Before 1996**

Potential impacts from wastes disposed of before 1996 were the same for all alternative groups. This discussion is presented under results for Alternative Group A (see Section 5.3.4.1.1).

#### **5.3.4.8.2 Wastes Disposed of After 1995**

Potential impacts for this alternative group reflect emplacement of LLW and MLLW disposed of after 2007 near the PUREX Plant and the disposal of melter and ILAW at ERDF. Results for LLW and MLLW disposed of after 2007 are identical to results for the same wastes in Alternative Group D<sub>1</sub> (see Section 5.3.4.4.2). Results for the melter and ILAW were the same as those calculated for Alternative Group E<sub>1</sub> (See Section 5.3.4.7.2).

#### **5.3.4.9 Alternative Group E<sub>3</sub>**

Alternative Group E<sub>3</sub> results for combined technetium-99 and iodine-129 concentration levels for the Hanford Only and Upper Bound waste volumes are summarized in Figures 5.19 and 5.20. Additional information can be found in several tables and figures in Volume II, Appendix G, Section G.2.9.

#### **5.3.4.9.1 Wastes Disposed of Before 1996**

Potential impacts from wastes disposed of before 1996 were the same for all alternative groups. This discussion is presented under results for Alternative Group A results in (see Section 5.3.4.1.1).

#### **5.3.4.9.2 Wastes Disposed of After 1995**

Potential impacts for this alternative group reflect emplacement of LLW and MLLW disposed of after 2007 at ERDF and the disposal of melter and ILAW near the PUREX Plant. Results for LLW and MLLW disposed of after 2007 are identical to results for the same wastes in Alternative Group D<sub>3</sub> (see Section 5.3.4.6.2). Results for the melter and ILAW were the same as those calculated for Alternative Group D<sub>1</sub> (see Section 5.3.4.4.2).

Combined technetium-99 levels were slightly less than 2.5 percent (22 pCi/L) of the benchmark MCL at the 200 East Area SE LOA for the Hanford Only waste volume. The potential impact for the Hanford Only waste volume reflects the potential impact of the melter and ILAW disposal near the PUREX Plant. The highest combined iodine-129 levels at the 200 East Area SE LOA were about 20 percent (0.2 pCi/L) of the benchmark MCL for both the Hanford Only and Upper Bound waste volumes as a result of the ILAW disposal near the PUREX area.

#### **5.3.4.10 No Action Alternative**

The No Action Alternative for combined technetium-99 and iodine-129 concentration levels are summarized in Figure 5.21. As was provided in the previous alternative groups, these results show the potential impacts to groundwater quality at various lines of analysis from: 1) early releases of technetium-99 and iodine-129 to groundwater from LLW disposed of prior to 1995 that peak in the next 100 to 200 years, 2) later releases of the same constituents from LLW and MLLW disposed of after 1996 that peak between the years 3000 and 4000, and 3) later increasing releases of technetium-99 and iodine-129 from ILAW disposal that peak at the end of the period of analysis (that is, the year 12,046 A.D.). Additional information can be found in several tables and figures in Volume II, Appendix G, Section G.2.10.

#### **5.3.4.10.1 Wastes Disposed of Before 1996**

The highest potential groundwater quality impacts from wastes disposed of before 1996 are related to technetium-99 and iodine-129 releases. Estimated concentrations of technetium-99 and iodine-129 peaked at about 110 years after the assumed start of release at the 200 East Area NW LOA and about 220 years after the assumed start of release at the 200 West Area LOA. Combined levels of technetium-99 were less than 2 percent (18 pCi/L) at the 200 East Area NW and the 200 West Area LOAs. Combined levels of iodine-129 at the 200 East Area NW LOA were less than 0.1 percent (0.09 pCi/L) of the benchmark MCL.

Combined levels of iodine-129 at the 200 West Area LOA were about 50 percent (0.5 pCi/L) of the benchmark MCL. This concentration level resulted from releases of the iodine-129 inventory in 1970-1987 LLW.

Concentration levels of carbon-14 and the uranium isotopes were found to peak at about or beyond 10,000 years after site closure. Carbon-14 concentrations were well below the benchmark MCL of 2000 pCi/L at the 200 East and West Area LOAs. Concentration levels of uranium-238, the dominant uranium isotope, were also well below the benchmark MCL of 30 pCi/L at the 200 East and West Area LOAs at 10,000 years after site closure. Uranium-238 concentrations reached a peak of about 3 pCi/L at their peak (between 14,000 and 16,000 years after site closure) at the 200 West Area LOA.

Combined technetium-99 and iodine-129 concentrations were well below benchmark MCLs by the time they reached the Columbia River. Overall concentration levels from sources in the 200 East Area reached their peaks at the Columbia River LOA at about 260 years after the assumed start of release. Contaminant levels from sources in the 200 West Area reached their peaks at the Columbia River LOA between 500 and 600 years after the assumed start of release.

#### **5.3.4.10.2 Wastes Disposed of After 1995**

The highest potential groundwater quality impacts from LLW and MLLW disposed of after 1995 resulted from releases of technetium-99 and iodine-129. Combined technetium-99 levels at the 200 East Area NW LOA were about 8 percent (77 pCi/L) of the benchmark MCL for the Hanford Only waste volume. The primary source for these elevated levels was from inventories in MLLW disposed of after 1995.

Combined technetium-99 levels were about 25 percent (225 pCi/L) of the benchmark MCL at the 200 West Area LOA. The source of these potential impacts was primarily from the technetium-99 inventory in Cat 3 LLW disposed of after 1995.

The highest combined iodine-129 levels were about 6 percent (0.06 pCi/L) of the benchmark MCL at the 200 West Area LOA for the Hanford Only waste volume. The main contributor to these concentration levels was from inventories in MLLW disposed of after 1995.

Concentration levels of carbon-14 and the uranium isotopes at the LOAs downgradient from source areas of LLW and MLLW disposed of after 1995 did not reach their peak values until after the

10,000-year period of analysis. Concentration levels for both constituents were well below the benchmark MCLs at 10,000 years after site closure.

Combined technetium-99 and iodine-129 concentrations were well below the benchmark MCL by the time they reached the Columbia River. Overall concentration levels at the Columbia River LOA from sources in the 200 East Area reached their peaks at about 850 years after site closure. Contaminant levels from sources in the 200 West Area reached their peaks near the river between 1660 and 1820 years after site closure.

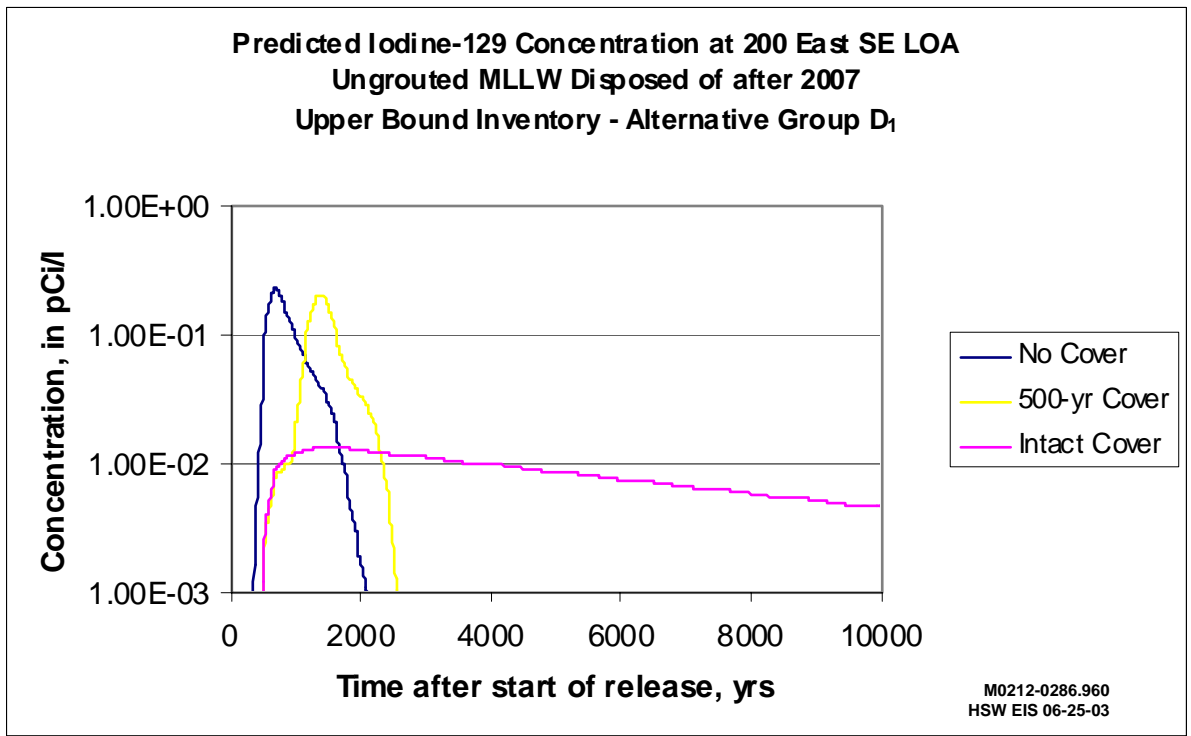
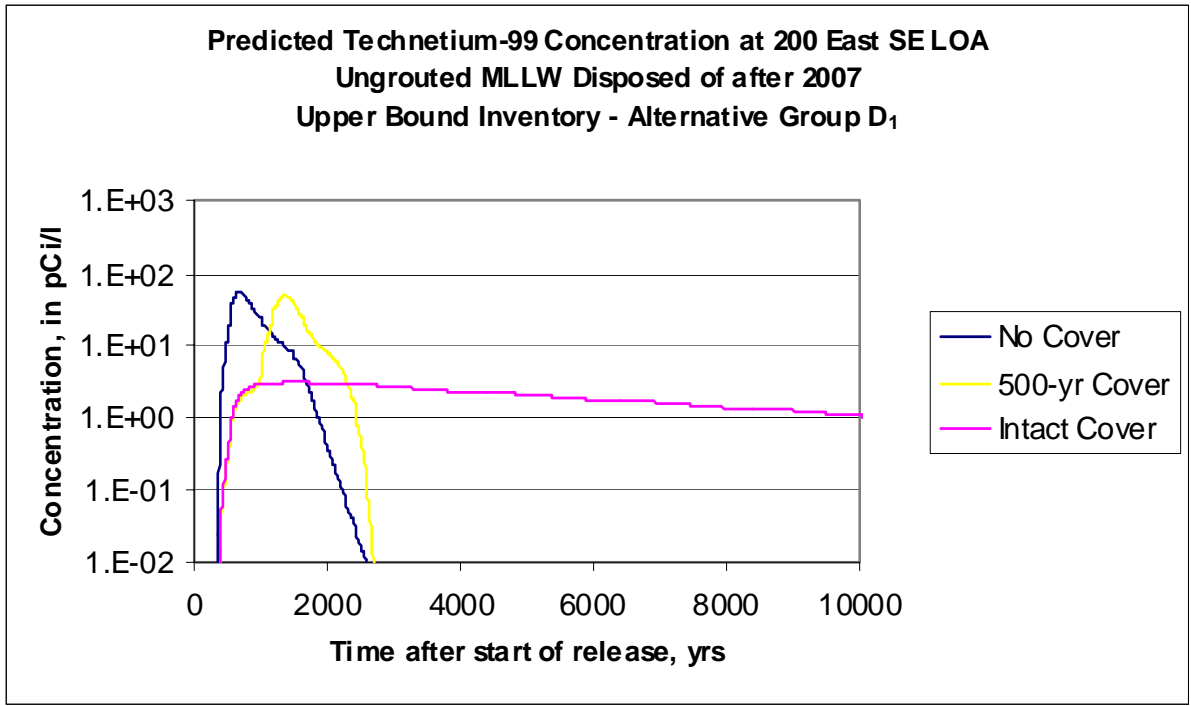
### **5.3.5 Effect of Long-Term Cover System Performance Assumptions**

This section presents results from a set of cases that was evaluated to examine and illustrate the effect of changing assumptions related to cover system performance on predicted groundwater quality impacts. The cases evaluated were related to groundwater impacts from selected waste categories and configurations proposed under Alternative Group D<sub>1</sub>. Two specific assumptions evaluated were as follows:

- No cover is assumed to exist and waste release is controlled by infiltration through natural vegetated surface conditions that likely would persist following site closure. The assumed infiltration rate for these conditions is 0.5 cm/yr.
- The Modified RCRA Subtitle C Cover system is assumed to persist for the entire period of analysis and waste release is assumed to be controlled by the cover design infiltration rate of 0.01 cm/yr.

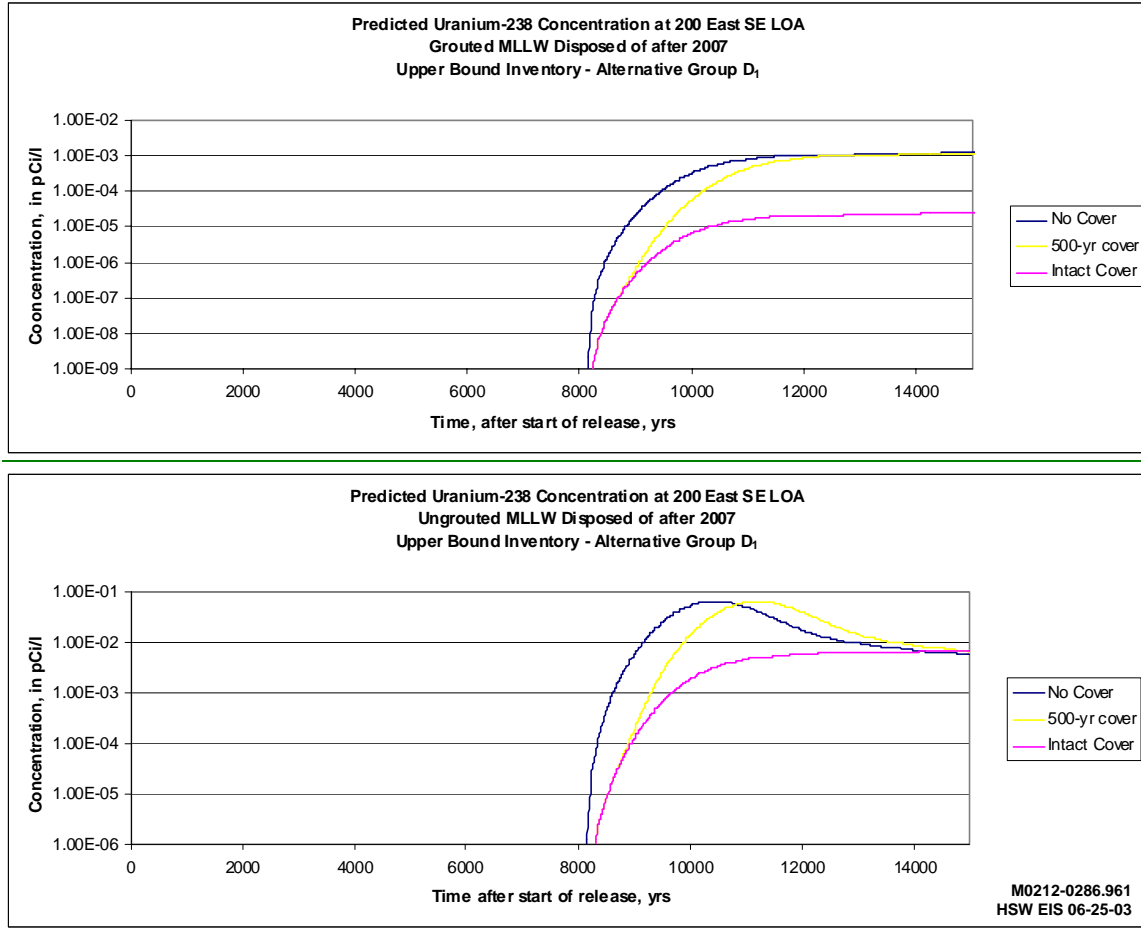
The specific contaminants and waste categories evaluated in these sensitivity cases included ungrouted Upper Bound inventories of technetium-99 and iodine-129 contained in MLLW and ungrouted and grouted Upper Bound inventories of uranium-238 contained in MLLW (see Figures 5.22 and 5.23). These specific examples illustrate the effect of the cover assumptions for contaminants from Mobility Class 1 ( $K_d = 0.0 \text{ mL/g}$ ) and Mobility Class 2 ( $K_d=0.6 \text{ mL/g}$ ).

A comparison of results based on the current conservative cover system assumption of failure after 500 years and a return to natural infiltration within 500 years after failure produces very similar potential impacts to those predicted with the assumption that no cover system is used. For all cases examined, differences in the results show predicted peak concentrations at the 1-km LOA, based on the 500-year cover system assumption, to be slightly lower and to arrive about 600 to 700 years later than the calculated peak concentrations at the 1-km LOA for the no-cover assumption. The delay in arrival time is reflective of the effect of the lower infiltration and release rate that would be expected to occur when the cover system is assumed to operate at or near its design infiltration of 0.01 cm/yr for the first 600 to 700 years after closure.



**Figure 5.22.** Comparison of Predicted Peak Concentrations of Technetium-99 and Iodine-129 at 200 East SE LOA from Upper Bound Inventories in Ungrounted MLLW Disposed of After 2007





**Figure 5.23.** Comparison of Predicted Peak Concentrations of Uranium-238 at 200 East SE LOA from Upper Bound Inventories in Ungrouned and Grouted MLLW Disposed of After 2007

Figures 5.22 and 5.23 also compare resulting potential impacts using a calculational assumption where the cover system remains intact and does not fail during the period of analysis. For all cases examined, predicted peak concentrations at the 1-km LOA consistent with the intact cover system assumption are calculated to be about 7 percent of the peak and to arrive over a much longer period of time than the peak concentration arrival time at the 1-km LOA for the 500-year cover scenario (see Table 5.13). Results based on this assumption reflect the effect of the expected reduced infiltration and waste release from the waste disposal zone while the cover system is assumed to be intact and operating at its design infiltration rate of 0.01 cm/yr.

**Table 5.13.** Comparison of Predicted Peak Concentrations of Selected Constituents at the 200 East SE LOA from Upper Bound Inventories in Ungroued MLLW Disposed of After 2007

	500-Year Cover		No Cover		Intact Cover	
	Peak Concentration (pCi/L)	Peak Arrival Time (yrs)	Peak Concentration (pCi/L)	Peak Arrival Time (yrs)	Peak Concentration (pCi/L)	Peak Arrival Time (yrs)
<b>Ungroued MLLW</b>						
Tc-99	48.9	1,370	54.6	680	3.2	1,530
Iodine-129	0.21	1,370	0.23	680	1.3E-02	1,530
U-238	6.7E-02	11,200	6.7E-02	10,450	7.9E-03	20,000
<b>Groued MLLW</b>						
U-238	1.42E-03	20,000	1.43E-03	20,000	2.8E-05	20,000

### 5.3.6 Potential Groundwater Quality Impacts at Waste Management Area Boundaries for Selected Alternatives

Potential impacts on groundwater for Alternative Groups D<sub>1</sub>, D<sub>2</sub>, and D<sub>3</sub> within 100 meters of the aggregate low-level waste management areas (LLWMAs) (see Volume II, Appendix G) are provided in this section. The alternative groups, waste types, and disposal conditions are briefly restated to establish the framework for comparing the results. These additional analyses of potential groundwater quality impacts for the new combined-use facility (as presented for Alternative Groups D<sub>1</sub>, D<sub>2</sub>, and D<sub>3</sub>), also are presented in Section G.5 and provide a perspective on the relative potential impact at LLWMA boundaries about 100 meters downgradient of the aggregate waste disposal area versus potential impacts at the 1-km LOAs. A similar impact analysis is provided for LLW and MLLW disposed of before 2007 for another perspective. At the end of this section (Section 5.3.6.5), a qualitative discussion of estimates of impacts at LLWMA boundaries for Alternative Groups A, B, C, E, and the No Action Alternative are also provided.

Because of assumptions used in waste release, vadose zone transport, and introduction of constituent release to underlying groundwater, these analyses represent a very conservative evaluation, that is, an overestimate of potential water quality impacts in the vicinity of aggregate LLWMA boundaries (100 meters), and these analyses should not be considered a compliance analysis as required by DOE Order 435.1, RCRA closure, or CERCLA. The conservatism used in this analysis is particularly evident in the analysis of waste contained in LLBG 218-E-12B, where the aquifer system is predicted to become dry over the period of interest (see Volume II, Appendix G, Section G.5). Specific unit releases used to approximate potential impacts from waste categories and associated disposal areas were represented as a linear source just inside the aquifer system down-slope relative to the top of the basalt bedrock underlying this LLBG. This representation is a simplistic representation of the complex future migration of contaminants from this burial ground and resulting concentration levels estimated downgradient of LLWMA 2 likely would be substantially less than those reported here.

The broader comparative analysis of impacts at the 1-km LOAs presented in the previous section reflect a summation of predicted maximum concentrations for several waste categories regardless of their position on the LOA. These resulting concentrations also were used to provide a determination of the sum-of-fractions of benchmark MCLs for key constituents (that is, technetium-99 and iodine-129) for each alternative group. These results are presented in Section 5.3.6.4 and are also provided in Section 3.4 and the Summary of this HSW EIS. That approach, combining groundwater concentrations from separate waste sources, would not be appropriate for results of the LLWMA boundary analyses presented in this section because of differences in locations of the wastes in question within each LLWMA, the associated locations of estimated potential maximum concentration, and the timing of arrival for maximum potential concentrations from each waste category.

A discussion and summary of ratios to benchmark MCLs for technetium-99 and iodine-129 for each waste category in the three alternative groups (D<sub>1</sub>, D<sub>2</sub>, and D<sub>3</sub>) are presented in Section 5.3.6.4.

### **5.3.6.1 Alternative Group D<sub>1</sub>**

Wastes considered in Alternative Group D<sub>1</sub> are the same as those described for Alternative Group A. However, in Alternative Group D<sub>1</sub>, all wastes disposed of after 2007 would be placed in a single, lined, modular combined-use facility near the PUREX Plant. Results for waste disposed of before 2008 in Alternative Group D<sub>1</sub> are summarized in Table G.42 in Volume II, Appendix G. Waste disposed of after 2007 are summarized in Table G.43 in Volume II, Appendix G.

#### **5.3.6.1.1 Wastes Disposed of Before 2008**

Waste disposed of before 2008 consists of four categories: 1) pre-1970 LLW, 2) 1970–1987 LLW, 3) 1988–1995 LLW, and 4) 1996–2007 LLW and MLLW. The following sections provide brief summaries of potential groundwater quality impacts at about 100 meters downgradient from aggregate LLWMAs for each of these waste categories.

#### **Pre-1970 Low-Level Waste**

Pre-1970 LLW was primarily disposed of in LLBGs 218-E-10 (LLWMA 1) and 218-E-12B (LLWMA 2) in the 200 East Area and in LLBG 218-W-4C (LLWMA 4) in the 200 West Area. For these wastes, technetium-99 and iodine-129 released from the LLBGs would have the highest potential impact on groundwater quality.

Iodine-129 is estimated to be about 80 percent of the benchmark MCL and technetium-99, about 30 percent of the benchmark MCL 100 meters downgradient of LLWMA 2 in the 200 East Area. These resulting concentration levels estimated 100 meters downgradient of LLWMA 2 are deemed to be very conservative because of the approximation of release to groundwater in this area used in the current approach (see Volume II, Appendix G, Section G.5.3).

### **1970–1987 Low-Level Waste**

1970–1987 LLW was primarily disposed of in LLBGs 218-E-10 (LLWMAB (LLWMA 2) in the 200 East Area and in LLBG 218-W-4A (LLWMA 4), 218-W-3A, and 218-W-3E (LLWMA 3) in the 200 West Area. For these wastes, iodine-129 released from the LLBGs has the highest potential impact on groundwater quality.

Iodine-129 is estimated to be about 7 times higher than the benchmark MCL of 1 pCi/l 100 meters downgradient of LLWMA 2 in the 200 East Area. As in the case of pre-1970 LLW, these resulting concentration levels estimated 100 meters downgradient of LLWMA 2 are deemed to be very conservative because of the approximation of release to groundwater in this area used in the current approach (see Volume II, Appendix G, Section G.5.3).

### **1988–1995 Low-Level Waste**

1988–1995 LLW is primarily disposed of in LLBGs 218-E-10 (LLWMA 1) and 218-E-12B (LLWMA 2) in the 200 East Area, and in LLBG 218-W-3A and 218-W-5 (LLWMA 3) in the 200 West Area. For these wastes, technetium-99 and iodine-129 released from the LLBGs would have the highest potential impact on groundwater quality.

Iodine-129 is estimated to be about 5 percent of the benchmark MCL 100 meters downgradient of LLWMA 2 in the 200 East Area. Technetium-99 is estimated to be about 7 percent of the benchmark MCL 100 meters downgradient of LLWMA 2 in the 200 East Area and about 9 percent of the benchmark MCL 100 downgradient of LLWMA 3 in the 200 West Area.

As in the case of pre-1970 LLW, concentration levels estimated 100 meters downgradient of LLWMA 2 are deemed to be very conservative because of the approximation of release to groundwater in this area used in the current approach (see Volume II, Appendix G, Section G.5.3).

### **1996–2007 LLW and MLLW**

1996–2007 wastes are and will be primarily disposed of in LLBGs 218-E-10 (LLWMA 1) and 218-E-12B (LLWMA 2) in the 200 East Area and in LLBG 218-W-3A and 218-W-5 (LLWMA 3) in the 200 West Area. Following is a brief summary of potential groundwater quality impacts from the three main components of these wastes, including Cat 1 LLW, Cat 3 LLW, and MLLW, as follows:

**Category 1 LLW** – Iodine-129 and technetium-99 released from 1996–2007 Cat 1 LLW primarily located in LLBG 218-W-5 within LLWMA 3 would have the highest potential impact on groundwater quality. Iodine-129 levels are estimated to be about 15 to 18 percent of the benchmark MCL 100 meters downgradient of LLWMA 3 in the 200 West Area for the Hanford Only and Upper Bound waste volumes. Technetium-99 levels are estimated to be about 1 and 2 percent of the benchmark MCL 100 meters downgradient of LLWMA 3 in the 200 West Area.

**Category 3 LLW** – Technetium-99 released from 1996–2007 Cat 3 LLW primarily located in LLBG 218-W-5 within LLWMA 3 would have the highest potential impact on groundwater quality. Technetium-99 levels are estimated to be about 2 percent of the benchmark MCL 100 meters downgradient of LLWMA 3 in the 200 West Area.

**MLLW** – Technetium-99 and iodine-129 released from ungrouted 1996–2007 MLLW would have the highest potential impact on groundwater quality. Concentration levels of all constituents are below benchmark MCLs for grouted 1996–2007 MLLW.

Estimated technetium-99 concentrations are about 21 percent of the benchmark MCL 100 meters downgradient of LLWMA 3 for all waste volumes. Estimated iodine-129 concentrations are about 48 and 80 percent of the benchmark MCL 100 meters downgradient of LLWMA 3 for the Hanford Only and Upper Bound waste volumes and about equal to the benchmark MCL 100 meters downgradient of LLWMA 2 for the Upper Bound waste volume.

As in the case of pre-1970 LLW, concentration levels estimated 100 meters downgradient of LLWMA 2 are deemed to be very conservative because of the approximation of release to groundwater in this area used in the current approach (see Volume II, Appendix G, Section G.5.3).

#### **5.3.6.1.2 Waste Disposed of After 2007 Near the PUREX Plant**

The potential impact for waste disposed of after 2007 reflects the emplacement of all wastes in the vicinity of the PUREX Plant. Potential impacts from LLW and MLLW would be dominated by technetium-99 and iodine-129.

The maximum potential impact from technetium-99 would be from Cat 3 LLW, where estimated concentration levels are about 21 percent of the benchmark MCL for both the Hanford Only and Upper Bound waste volumes. The maximum potential impact from iodine-129 would be from ungrouted MLLW, where estimated concentration levels are about 29 and 26 percent of the benchmark MCL for the Hanford Only and Upper Bound waste volumes.

Estimated concentration levels of all other constituents in these waste categories and all constituents in other waste categories are well below benchmark MCLs.

#### **5.3.6.2 Alternative Group D<sub>2</sub>**

Wastes considered in Alternative Group D<sub>2</sub> are the same as those described for Alternative Group D<sub>1</sub>. However, in Alternative Group D<sub>2</sub>, all wastes disposed of after 2007 would be placed in a single, lined, modular combined-use facility at LLBG 218-E-12B. Results for waste disposed of before 2008 in Alternative Group D<sub>2</sub> are summarized in Table G.42 in Volume II, Appendix G. Waste disposed of after 2007 are summarized in Table G.44 in Volume II, Appendix G.

#### **5.3.6.2.1 Wastes Disposed of Before 2008**

Because of assumptions in the source-term release and vadose zone modeling used for LLW disposed of before 2008 for Alternative Group D, results for Alternative Group D<sub>2</sub> are the same as those for waste categories calculated for Alternative Group D<sub>1</sub>. These results are summarized in Table G.42 of Volume II, Appendix G.

#### **5.3.6.2.2 Waste Disposed of After 2007 in LLBG 218-E-12B**

The highest potential impact for this alternative group reflects the emplacement of all wastes disposed of after 2007 in LLBG 218-E-12B. Potential impacts from LLW and MLLW would be dominated by technetium-99 and iodine-129 (see Volume II, Appendix G, Table G.44).

The maximum potential impact from technetium-99 would be from Cat 3 LLW, where estimated concentration levels are about 86 percent of the benchmark MCL for all waste volumes. The maximum potential impact from iodine-129 would be from ungrouted MLLW, where estimated concentration levels are about 94 and 95 percent of the benchmark MCL for both the Hanford Only and Upper Bound waste volumes. In addition, the potential impact from iodine-129 would be from Cat 3 LLW, where estimated concentration levels are about 38 percent of the benchmark MCL for both the Hanford Only and Upper Bound waste volumes. These higher levels of potential groundwater quality impacts relative to those calculated for similar waste inventories in Alternative Group D<sub>1</sub> reflect differences in aquifer conditions found beneath the near PUREX location (that is, high permeability and moderate saturated thickness of the Hanford formation at the water table) and the 218-E-12B LLBG (that is, slightly lower hydraulic conductivities and thinner saturated thicknesses of the Hanford formation at the water table).

Estimated concentrations of all other constituents in these waste categories and all constituents in other waste categories would be below benchmark MCLs.

As in the case of other wastes disposed of in LLBG 218-E-12B, the resulting concentration levels estimated about 100 meters downgradient of LLWMA 2 are deemed to be very conservative because of the approximation of release to groundwater in this area used in the current approach (see Volume II, Appendix G, Section G.5.3).

#### **5.3.6.3 Alternative Group D<sub>3</sub>**

Wastes considered in Alternative Group D<sub>3</sub> are the same as those described for Alternative Group D<sub>1</sub>. However, in Alternative Group D<sub>3</sub>, all wastes received after 2007 would be disposed of in a single, lined, modular combined-use facility at ERDF. Results for waste disposed of before 2008 in Alternative Group D<sub>3</sub> are summarized in Table G.42 in Volume II, Appendix G. Waste disposed of after 2007 are summarized in Table G.45 in Volume II, Appendix G.

#### **5.3.6.3.1 Wastes Disposed of Before 2008**

Because of assumptions in the source-term release and vadose zone modeling used for LLW previously disposed of before 2008 for Alternative Group D, results for Alternative Group D<sub>3</sub> are the same as for those for waste categories calculated for Alternative Group D<sub>1</sub>. These results are summarized in Table G.45 of Volume II, Appendix G.

#### **5.3.6.3.2 Waste Disposed of After 2007**

The highest potential impact for this alternative group reflects the emplacement of all wastes disposed of after 2007 at ERDF. Potential impacts from LLW and MLLW would be dominated by technetium-99 and iodine-129 (see Volume II, Appendix G, Table G.45).

The maximum potential impact from technetium-99 would be from Cat 3 LLW, where estimated concentration levels are about 81 and 58 percent of the benchmark MCL for the Hanford Only and Upper Bound waste volumes. The maximum potential impact from iodine-129 would be from ungrouted MLLW, where estimated concentration levels are about 94 and 74 percent of the benchmark MCL for both the Hanford Only and Upper Bound waste volumes, respectively. In addition, the potential impact from iodine-129 from Cat 3 LLW would be about 36 and 28 percent of the benchmark MCL for the Hanford Only and Upper Bound waste volumes. These higher levels of potential groundwater quality impacts relative to those calculated for similar waste inventories in Alternative Group D<sub>1</sub> reflect differences between aquifer conditions found beneath the near PUREX location (that is, high permeability and moderate saturated thickness of the Hanford formation at the water table) and at ERDF (that is, lower hydraulic conductivities associated with the Ringold Formation at the water table).

Estimated concentrations of all other constituents in these waste categories and all constituents in other waste categories would well be below benchmark MCLs.

#### **5.3.6.4 Summary of Ratios to Benchmark MCLs for Technetium-99 and Iodine-129**

This section presents a discussion of the combined ratios of maximum potential concentrations to benchmark MCLs for technetium-99 and iodine-129 using the sum-of-fractions rule for all wastes considered in the three alternative groups. The breakdown is provided in two broad categories—1) waste disposed of before 2008 and 2) waste disposed of after 2007—and includes results for the Hanford Only and Upper Bound waste volumes.

##### **5.3.6.4.1 Waste Disposed of Before 2008**

The sum-of-fractions of maximum potential concentrations as compared with benchmark MCLs for technetium-99 and iodine-129 for waste disposed of before 2008, as presented in Table 5.14, are the same for all three alternative groups. Each waste category was evaluated as a separate entity because of differences in locations of the wastes in question within each LLWMA, the associated locations of estimated potential maximum concentration, and the timing of arrival for maximum potential concentrations from each waste category. Because of the higher waste containment integrity used for waste disposed of

**Table 5.14.** Sum of MCL Fractions and Drinking Water Doses from Maximum Potential Concentrations at LLWMA Boundaries for Technetium-99 and Iodine-129 for Waste Buried Before 2008

Primary Contributing Waste Category	200 East Area				200 West Area			
	Ratios of Maximum Potential Concentrations to Benchmark MCL			Estimated Dose (mrem/yr)	Ratios of Maximum Potential Concentrations to Benchmark MCL			Estimated Dose (mrem/yr)
	Tc-99	I-129	Sum-of-Fractions <sup>(a)</sup>		Tc-99	I-129	Sum-of-Fractions	
Pre-1970 LLW	0.4	0.8	1.2	0.5	0.03	0.04	0.07	0.04
1970–1987 LLW	NA	7.2	7.2	1.5	NA	0.05	0.05	0.01
1988–1995 LLW	0.1	0.1	0.2	0.1	0.07	4.2	4.3	1.0
1996–2007 Cat 3 LLW								
Hanford Only	NA	NA	NA	NA	0.03	NA	0.03	0.03
Upper Bound	NA	NA	NA	NA	0.03	NA	0.03	0.03
1996–2007 MLLW								
Hanford Only	NA	NA	NA	NA	0.2	0.8	1.0	0.3
Upper Bound	0.3	1	1.3	0.5	0.1	0.5	0.7	0.2

(a) Sum-of-fractions greater than 1.0 would indicate a potential cumulative exceedance of benchmark MCLs.  
NA = not applicable.

after 1995, waste releases of mobile constituents (that is, technetium-99 and iodine-129) to groundwater after 1995 would be delayed from release to groundwater from waste disposed of before or during 1995 by several hundred years.

As in the case for LLW disposed of in LLWMA 2 for Alternative Groups D<sub>1</sub> and D<sub>2</sub> (see Sections 5.3.6.1.1 and 5.3.6.2.1), concentration levels estimated 100 meters downgradient for LLW disposed of in LLWMA 2 are deemed to be very conservative because of the approximation of release to groundwater in this area used in the current approach (see Volume II, Appendix G, Section G.5.3).

The largest sum-of-fractions were calculated from maximum potential concentrations estimated for iodine-129 contained in 1970–1987 wastes disposed of in LLBGs in the 200 East Area and in 1988–1995 LLW disposed of in LLBGs (mainly 218-W-5 and 218-W-3A) in the 200 West Area. The arrival of maximum concentration levels at the given LLWMA boundary were estimated to occur at about 90 years from the start of release in the 200 East Area and at about 150 years from the start of release for wastes in the 200 West Area. The assumed start of release for both areas was 1966. These relatively short arrival times of maximum concentrations reflect the assumptions used in the release of waste disposed of before 1995, that is, using a relatively high infiltration rate of 5.0 cm/yr in waste release and vadose zone transport. The maximum concentration would be expected to persist at the LLWMA boundary for a



relatively short period of time (a few decades) after initial arrival and would dissipate within the period of active institutional control (that is, 100 years after site closure), during which time ground water use within the Central Plateau would be restricted.

As may be seen from Table 5.14, potential exceedances of benchmark MCLs using the sum-of-fractions rule (that is, sum-of-fractions greater than 1.0) are evident; however, it may also be noted that drinking water doses are below the benchmark DOE drinking water standard of 4 mrem/yr at the LLWMA boundary points of analysis.

#### **5.3.6.4.2 Waste Disposed of After 2007**

Combined ratios of maximum potential concentrations to benchmark MCLs for technetium-99 and iodine-129 for waste disposed of after 2007 are presented in Table 5.15 for all three alternative groups. In this case, the wastes would be disposed of within a combined-use facility. They are evaluated separately from the wastes disposed of before 2008 because of differences in locations of the wastes in question within each LLWMA, the associated locations of estimated potential maximum concentration, and the timing of arrival for maximum potential concentrations from each waste category. Because of the improved waste isolation and containment used in disposal of waste between 1996 and 2007, releases of mobile constituents (that is, technetium-99 and iodine-129) from these wastes to groundwater would be separated from releases to groundwater from waste disposed of before 1996 by several hundred years. In addition, the use of a glass waste form for waste in ILAW would cause releases of mobile constituents from these wastes to groundwater to be separated from releases to groundwater from waste disposed of before 1996 by several thousand years.

For the three alternative groups considered, the calculated sum-of-fractions would be lowest if the combined-use facility were sited near the PUREX Plant location (Alternative Group D<sub>1</sub>). The higher levels of potential groundwater quality impacts at the 218-E-12B (Alternative Group D<sub>2</sub>) and the ERDF (Alternative Group D<sub>3</sub>) locations relative to the near-PUREX location reflect differences in aquifer conditions found beneath the 218-E-12B LLBG (slightly lower hydraulic conductivities and thinner saturated thicknesses of the Hanford formation at the water table) and the ERDF (lower hydraulic conductivities associated with the Ringold Formation at the water table) locations.

For a combined-use facility near the PUREX Plant (Alternative Group D<sub>1</sub>), Table 5.15 shows that the benchmark MCLs using the sum-of-fractions rule would not be exceeded. For combined-use facilities at other LLWMA locations, potential exceedances of benchmark MCLs using the sum-of-fractions rule are evident; however, it should be noted that drinking water doses are below the DOE benchmark drinking water standard of 4 mrem/yr at the LLWMA boundary points of analysis.

**Table 5.15.** Sum of MCL Fractions and Drinking Water Doses from Maximum Potential Concentrations at Combined-Use Facility Boundaries for Technetium-99 and Iodine-129 for Waste Buried After 2007

Primary Contributing Waste Category	Ratios of Maximum Potential Concentrations to Benchmark MCL			Estimated Dose (mrem/yr)
	Technetium-99	Iodine-129	Sum-of-Fractions <sup>(a)</sup>	
<b>Near the PUREX Plant (Alternative Group D<sub>1</sub>)</b>				
<b>Cat 3 LLW</b>				
Hanford Only	0.2	0.1	0.3	0.2
Upper Bound	0.2	0.1	0.3	0.2
<b>MLLW</b>				
Hanford Only	0.1	0.2	0.3	0.1
Upper Bound	0.1	0.2	0.3	0.1
<b>Overall Totals</b>				
Hanford Only	0.3	0.3	0.6	0.4
Upper Bound	0.3	0.3	0.6	0.4
<b>218-E-12B LLBG (Alternative Group D<sub>2</sub>)</b>				
<b>Cat 3 LLW</b>				
Hanford Only	0.8	0.4	1.2	0.9
Upper Bound	0.8	0.4	1.2	0.9
<b>MLLW</b>				
Hanford Only	0.3	1.0	1.2	0.5
Upper Bound	0.3	1.0	1.2	0.5
<b>Overall Totals</b>				
Hanford Only	1.1	1.3	2.4	1.3
Upper Bound	1.1	1.3	2.4	1.3
<b>ERDF (Alternative Group D<sub>3</sub>)</b>				
<b>Cat 3 LLW</b>				
Hanford Only	0.9	0.4	1.2	0.9
Upper Bound	0.9	0.4	1.2	0.9
<b>MLLW</b>				
Hanford Only	0.3	0.9	1.2	0.5
Upper Bound	0.3	0.9	1.2	0.5
<b>Overall Totals</b>				
Hanford Only	1.1	1.2	2.3	1.3
Upper Bound	1.1	1.2	2.3	1.3

(a) Sum-of-fractions greater than 1.0 would indicate a potential cumulative exceedance of benchmark MCLs.

### **5.3.6.5 Qualitative Estimates of Impacts at LLWMA Boundaries for Alternative Groups A, B, C, E, and the No Action Alternative**

Although quantitative estimates of the impacts at the LLWMA boundaries were made only for Alternative Groups D<sub>1</sub>, D<sub>2</sub>, and D<sub>3</sub>, those results were used to make qualitative estimates of impacts that might be expected from the other action alternative groups (that is, A, B, C, E<sub>1</sub>, E<sub>2</sub>, and E<sub>3</sub>) and the No Action Alternative. The inferences are made based on evaluation of a combination of factors, including:

- similarities in assumed disposal configuration, mainly related to assumed waste depth
- similarities in hydrogeologic conditions at assumed disposal facility locations
- calculated ratios of predicted concentrations at the LLWMA boundaries and 1-km LOAs from similar source areas.

Ratios of predicted concentrations of the technetium-99 and iodine-129 calculated at the LLWMA boundaries and the 1-km LOAs were found to vary by waste category and disposal location. These ratios also vary within each LLWMA as a function of distance from the assumed disposal site to the LLWMA boundary. Calculated ratios for waste considered in Alternative Group D were found to vary as follows:

- Ratios for waste disposed of before 2008 varied from about 14 to 23 in the 200 East Area and from about 2 to 11 in the 200 West Area.
- Ratios for waste disposed of after 2007 varied from a low of 1.1 for waste assumed to be disposed of at the proposed facility near PUREX to a high of about 6 for waste assumed to be disposed of within the 218-E-12B LLBG.

The following sections provide a qualitative summary of impacts for the other action alternative groups (A, B, C, and E<sub>1</sub>, E<sub>2</sub>, and E<sub>3</sub>) and the No Action Alternative for all wastes postulated to be disposed of before 2008 and wastes that would be disposed of after 2007. The primary focus of this discussion is on the impacts from technetium-99 and iodine-129, because these constituents are associated with potential maximum impacts.

#### **5.3.6.5.1 Waste Disposed of Before 2008**

Because the assumptions used in the source-term release and vadose zone modeling for LLW and MLLW postulated to be disposed of before 2008 were the same for all the action alternative groups, potential concentration levels of technetium-99 and iodine-129 estimated for Alternative Group D (see Table G.42 in Volume II, Appendix G) for waste disposed of before 2008 would be directly applicable for all the action alternative groups.

The impacts at the LLWMA boundaries presented in Table G.42 in Volume II, Appendix G for waste disposed of before 1996 generally would be applicable to concentration levels of technetium-99 and iodine-129 estimated for the No Action Alternative. Because of the assumptions used in the surface cover

conditions, source release, and vadose zone transport for waste disposed of before 1996, the estimated maximum concentrations of technetium-99 and iodine-129 from these waste categories for the No Action Alternative were found to be similar to those estimated for the action alternative groups.

The impacts at the LLWMA boundaries presented in Table G.42 in Volume II, Appendix G for LLW and MLLW assumed to be disposed of between 1996 and 2007 also would be generally applicable to concentration levels of technetium-99 and iodine-129 estimated for LLW and MLLW assumed to be disposed of after 1995 in the No Action Alternative. However, maximum concentrations for technetium-99 and iodine-129 from waste disposed of after 1995 in the No Action Alternative would be expected to be higher for LLW and lower for MLLW due to the differences in assumed inventories of technetium-99 and iodine-129 between the No Action Alternative and the action alternative groups.

#### **5.3.6.5.2 Waste Disposed of After 2007**

The following sections provide a qualitative summary of potential groundwater quality impacts for LLW and MLLW assumed to be disposed of after 2007 with respect to Alternative Groups A, B, C, E<sub>1</sub>, E<sub>2</sub>, and E<sub>3</sub>. The potential impacts for LLW and MLLW assumed to be disposed of after 2007 in the No Action Alternative were discussed in the previous section.

#### **Alternative Group A**

This alternative group evaluates the following disposal options:

- Cat 1 and Cat 3 LLW and MLLW disposed of after 2007 in deeper (18 m) (59 ft) and wider trenches in existing LLBGs 218-W-5 and 218-E-12B
- melters disposed of after 2007 in a 21-m (69-ft) deep facility near PUREX
- ILAW disposed of after 2007 in a new HSW disposal facility near PUREX.

For LLW disposed of after 2007 in LLBG 218-W-5 within the 200 West Area, the increase in concentrations from the 1-km LOA to those calculated at the LLWMA 3 boundary for technetium-99 and iodine-129 would be expected to be similar to results for the Cat 1 and Cat 3 wastes disposed of between 1996 and 2007 in LLBG 218-W-5 in the 200 West Area in all the alternative groups. The ratio of results for technetium-99 and iodine-129 for LLW disposed of between 1996 and 2007 calculated at the LLWMA 3 boundary, shown in Table G.42 (see Volume II, Appendix G), and results at the 1-km LOA given for the same waste category (see Table G.7 in Volume II, Appendix G) suggest that concentrations at the LLWMA 3 boundary would be about a factor of 6 greater than those presented for the 1-km LOA.

For MLLW disposed of after 2007 in LLBG 218-E-12B within the 200 East Area, the increase in concentrations from the 1-km LOA to those calculated at the LLWMA 2 boundary for technetium-99 and iodine-129 would be expected to be similar to results for the MLLW disposed of after 2007 in Alternative Group D<sub>2</sub>. The ratio of results for technetium-99 and iodine-129 calculated at the LLWMA 2 boundary for the MLLW disposed of after 2007 in Alternative Group D<sub>2</sub>, shown in Table G.42 (see Volume II,

Appendix G), and results at the 1-km LOA given in Table G.7 (see Volume II, Appendix G) suggest that concentrations at the LLWMA 2 boundary would be about a factor of 6 greater than those presented for the 1-km LOA.

Technetium-99 and iodine-129 results from disposal of melters and ILAW would be expected to be similar to those calculated for these facilities near PUREX in Alternative Group D<sub>3</sub> (see Table G.45 in Volume II, Appendix G).

### **Alternative Group B**

LLW considered in Alternative Group B includes the same waste considered in Alternative Group A but assumes disposal of Cat 1 and Cat 3 LLW and MLLW in conventional trenches after 2007 in LLBGs 218-W-5 and 218-E-12B, melters in a trench in LLBG 218-E-12B, and ILAW in a new disposal facility located just south of the CWC.

For LLW disposed of after 2007 in LLBG 218-W-5 within the 200 West Area, the increase in concentrations from the 1-km LOA to those calculated at the LLWMA 3 boundary for technetium-99 and iodine-129 would be expected to be similar to results for the Cat 1 and Cat 3 wastes disposed of between 1996 and 2007 in LLBG 218-W-5 in the 200 West Area for all the alternative groups. The ratio of results for technetium-99 and iodine-129 for LLW disposed of between 1996 and 2007 calculated at the LLWMA 3 boundary, shown in Table G.42 (see Volume II, Appendix G), and results at the 1-km LOA given for the same waste category (see Table G.7 in Volume II, Appendix G) suggest that concentrations at the LLWMA 3 boundary would be about a factor of 6 greater than those presented for the 1-km LOA.

For MLLW disposed of after 2007 in LLBG 218-E-12B within the 200 East Area, the increase in concentrations from the 1-km LOA to those calculated at the LLWMA 2 boundary for technetium-99 and iodine-129 would be expected to be similar to results for the MLLW disposed of after 2007 in Alternative Group D<sub>2</sub>. The ratio of results for technetium-99 and iodine-129 calculated at the LLWMA 2 boundary, shown in Table G.43 (see Volume II, Appendix G), and results at the 1-km LOA, given in Table G.22 (see Volume II, Appendix G), suggest that concentrations at the LLWMA 2 boundary would be about a factor of 6 greater than those presented for the 1-km LOA.

Results for the melters would be expected to be similar to those calculated for Alternative Group D<sub>2</sub> (see Section 5.3.6.2.2 and Table G.44 in Volume II, Appendix G). Results suggest that concentrations at the LLWMA 2 boundary would be about a factor of 5 greater than those presented for the 1-km LOA.

For ILAW disposed of after 2007 south of the CWC, the increase in concentrations at the LLWMA 4 boundary relative to the 1-km LOA for technetium-99 and iodine-129 would be expected to be similar to results for the Cat 1 and Cat 3 LLW disposed of after 2007 at ERDF in Alternative Group D<sub>3</sub>. Although the disposal site south of CWC is several kilometers from the ERDF location, both disposal sites are in areas underlain with similar hydrogeologic units (that is, Ringold Formation Unit 5) that exist below the water table. The ratio of results for technetium-99 and iodine-129 calculated for Cat 1 and Cat 3 LLW at the ERDF boundary, shown in Table G.45 (see Volume II, Appendix G), and results at the 1-km LOA for

the same waste category, given in Table G.25 (see Volume II, Appendix G), suggest that concentrations at the ERDF boundary would be about a factor of 3 greater than those presented for the 1 km LOA.

### **Alternative Group C**

Because of assumptions in the source-term release and vadose zone modeling used for previously buried LLW and LLW and MLLW disposed of after 2007 for Alternative Group C, results for LLW and MLLW disposed of after 2007 for this alternative group, including the ILAW and melters, would be expected to be similar to those qualitatively discussed for Alternative Group A. These results are consistent because the analysis assumption about waste depth and projected land use for waste disposed of after 2007 are the same for both alternative groups.

### **Alternative Group E<sub>1</sub>**

The potential impacts for this alternative group reflect emplacement of LLW and MLLW disposed of after 2007 in LLBG 218-E-12B and disposal of melters and ILAW at ERDF. Results for LLW and MLLW disposed of after 2007 would be expected to be similar to results for the same wastes in Alternative D<sub>2</sub> (see Table G.44 in Volume II, Appendix G). Results for the disposal of melters and ILAW would be expected to be similar to those calculated for these facilities in Alternative Group D<sub>3</sub> (see Table G.45 in Volume II, Appendix G).

### **Alternative Group E<sub>2</sub>**

The potential impacts for this alternative group reflect emplacement of LLW and MLLW disposed of after 2007 near PUREX and the disposal of melters and ILAW at ERDF. Results for LLW and MLLW disposed of after 2007 would be expected to be similar to results for the same wastes in Alternative Group D<sub>1</sub> (see Section 5.3.6.1.2 and Table G.43 in Volume II, Appendix G). Results for the melters and ILAW would be expected to be similar to those calculated for Alternative Group D<sub>3</sub> (see Section 5.3.6.3.2 and Table G.45 in Volume II, Appendix G) and Alternative Group E<sub>1</sub> (see the preceding paragraph).

### **Alternative Group E<sub>3</sub>**

The potential impacts for this alternative group reflect emplacement of LLW and MLLW disposed of after 2007 at ERDF and the disposal of melters and ILAW near PUREX. Results for LLW and MLLW disposed of after 2007 would be expected to be similar to results for the same wastes in Alternative Group D<sub>3</sub> (see Section 5.3.6.3.2 and Table G.45 in Volume II, Appendix G). Results for the melters and ILAW would be expected to be similar to those calculated for Alternative Group D<sub>1</sub> (see Section 5.3.6.3.1 and Table G.43 in Volume II, Appendix G).

#### **5.3.6.5.3 Summary of Results for Disposal Alternatives**

Results of the detailed analyses of the subalternatives in Alternative Group D and the qualitative analysis of for the other Alternative Groups (A, B, C, and E) at LLWMA boundaries lead to the following general conclusions:

- The range of potential groundwater quality impacts at disposal facility boundaries for the alternative groups is largely reflective of differences in hydrogeologic conditions found beneath different postulated disposal facility locations. Differences in potential impacts also are, to a lesser extent, a function of assumed disposal facility configurations.
- Maximum concentrations of technetium-99 and iodine-129 conservatively estimated from a combined-use facility at the range of disposal facility locations yielded potential exceedances of benchmark MCLs using the sum-of-fractions rule for two of the subalternatives in Alternative Group D. However, associated drinking water doses were found to be below the DOE benchmark drinking water standard of 4 mrem/yr at the LLWMA boundary points of analysis for the subalternatives in Alternative Group D. Detailed analysis of the other alternative groups (A, B, C, and E) likely would lead to the same general human health impact (that is, estimated potential drinking water doses would be below the DOE benchmark drinking water standard of 4 mrem/yr at the LLWMA or disposal area boundary points of analysis).
- From the standpoint of estimated impacts at LLWMA boundaries, the most favorable alternative for LLW and MLLW disposed of after 2007 appears to be Alternative Group D<sub>1</sub> where all LLW and MLLW, including melters and ILAW, are assumed to be disposed of near the PUREX Plant. This site would have the lowest estimated impacts because of the high permeability and moderate saturated thickness of the Hanford formation sediments found at the water table beneath this location.
- For the same assumed LLW and MLLW inventories, higher impacts would be expected at the LLWMA boundaries for alternative groups that consider disposal of wastes within the 218-W-5 and 218-E-12B LLBGs and at the ERDF location. These impacts would be expected to be higher because of the hydrogeologic conditions found at the water table at these locations (that is, slightly lower hydraulic conductivities and thinner saturated thicknesses of the Hanford formation at the water table at the 218-E-12B LLBG and the lower permeability of the Ringold Formation found at the water table at the 218-W-5 LLBG and ERDF locations).

### **5.3.7 Potential Groundwater Quality Impacts from Hazardous Chemicals in Pre-1988 Wastes**

In response to comments received during the public comment periods on the drafts of the HSW EIS, efforts were made to develop an estimate of quantities of potentially hazardous chemicals in previously buried LLW so that potential impacts of such chemicals on groundwater quality could be evaluated. The estimation of these inventories, which used a waste stream analysis estimation method, is summarized in the Technical Information Document (FH 2004).

The most substantial quantities of hazardous chemicals (in terms of inventory quantities) identified from this effort are summarized in Table 5.16. These specific, selected hazardous chemical inventories provided the basis for the following analysis of potential groundwater quality impacts from hazardous chemical inventories in wastes disposed of before 1988.

**Table 5.16.** Estimated Inventories of Selected Hazardous Chemicals Potentially Disposed of in HSW LLBGs Between 1962 and 1987

Constituent	Inventory (kg)
Chromium	100
Fluoride	5,000 <sup>(a)</sup>
Nitrate	5,000 <sup>(b)</sup>
Lead	>600,000
Mercury	1,000
1,1,1-trichloroethane	900
Xylene	3,000
Toluene	3,000
Methylene chloride	800
Oil	3,000
Diesel fuel	20,000
Hydraulic fluid	40,000
PCBs	8,000
(a) Fluoride mass equivalent for 10,000 kg of sodium fluoride.	
(b) Nitrate mass equivalent to 6,000 kg of sodium nitrate.	

### 5.3.7.1 Contaminant Group and Screening Analysis

As was done in the impact analysis for radiological constituents, the potential for each of the hazardous chemical constituents to impact groundwater was evaluated. Screening of these constituents evaluated their relative mobility in the subsurface system within a 10,000-year period of analysis. In addition, because of the presence of several organic chemicals in the table, the screening also considered the potential for chemical degradation within the period of analysis.

As in the radiological constituent analysis, the constituents were grouped based on their mobility in the vadose zone and underlying unconfined aquifer using estimated or assumed  $K_d$  for each constituent as a measure of mobility. A summary of all hazardous constituents using the same mobility groupings (based on  $K_d$  values) described in Section G.1.3.1 is provided in Table G.49 (both in Volume II, Appendix G).

The mobility of constituents in Table G.49 in Volume II, Appendix G were further evaluated using estimates of constituent transport times through the thick vadose zone to the unconfined aquifer during the 10,000-year period of analysis described in Section G.1.3.1. Based on a natural infiltration rate of 0.5 cm/yr through the underlying vadose zone (see the screening analysis method described in Volume II, Appendix G, Section G.1.3.1) and the estimated levels of sorption and associated retardation for each of the classes above, travel times of all constituents were estimated. Results of this analysis show that without a substantial driving force, arrival times of constituents within Mobility Classes 3, 4, and 5 through the thick vadose zone to the unconfined aquifer beneath the LLBGs were calculated to be well



beyond the 10,000-year period of analysis. Thus all constituents in these classes were eliminated from further consideration. The constituents eliminated from further consideration include diesel fuel, hydraulic fluid, oil, lead, mercury, and PCBs.

Because the constituent list evaluated includes a few volatile organic chemicals, the effect of potential biotic and abiotic degradation and volatilization also were examined in the constituent screening process. Table G.50 (see Volume II, Appendix G), which provides generic estimates of the biotic and abiotic degradation for selected chemicals, suggests that degradation, particularly biotic degradation, may be an important factor in reducing inventories of the organic constituents in question. Table G.51 (see Volume II, Appendix G), which provides some laboratory estimates of volatilization rates, suggests that this process also would be important. Consideration of relatively high degradation and volatilization rates for the compounds in question provided the basis for eliminating the volatile organic chemicals within Mobility Class 1 including: 1,1,1-trichloroethane, xylene, toluene, and methylene chloride. No contaminants were identified in Mobility Class 2.

While these organic compounds would be expected to be reduced in source areas by the processes of degradation and volatilization, the impact from breakdown products generated from degradation of the constituents in question potentially exists. While these impacts were not evaluated in detail, the general types of by-product compounds that could be formed were examined qualitatively to identify other potential constituents of concern.

Breakdown products from the above constituents may be produced from combinations of three subsurface processes. Two of these processes include biotic degradation by microorganisms under aerobic or anaerobic conditions. In the absence of viable microbial populations, abiotic degradation, which usually occurs as a result of chemical hydrolysis of the constituent, may also occur. Breakdown of these constituents have generally established degradation pathways resulting in the formation of a number of intermediate breakdown products. Intermediate breakdown products that are regulated would be of most interest from an impact perspective.

A review of established degradation pathways for the four constituents (Jordan and Payne 1980; Truex et al. 2001; Vogel et al. 1987) identified two regulated byproducts of greatest potential concern: 1,1-dichloroethene and vinyl chloride, which would be associated with degradation of 1,1,1-trichloroethane. Methylene chloride produces chloromethane as a breakdown product (EPA 2000a), but chloromethane is not regulated compound. Toluene and xylene produce breakdown products that are common constituents found in lignin (woody materials) and that break down in natural biological cycles. Such breakdown products are not regulated (EPA 2000a).

The final list of constituents considered for further analysis include the remaining inorganic chemicals in Mobility Class 1—chromium, fluoride, and nitrate.

### **5.3.7.2 Methods and Other Key Assumptions**

The following hypothetical groundwater quality impacts associated with hazardous chemicals contained in waste disposed of before 1988 were based on the same source-term release and vadose

transport calculations for the main comparative analysis described in Volume II, Appendix G, Sections G.1.3 and G.1.4, for this waste category. Little is known about the actual quantities and distribution of hazardous chemicals, hence the analysis based on the estimated inventory of the selected constituents should be considered an approximation of the potential impacts from these hazardous chemicals in disposed of wastes. For purposes of these calculations, the entire hazardous chemical inventory was conservatively assumed to be uniformly disposed of in wastes contained within the 218-W-4B LLBG in the 200 West Area. The wastes currently disposed of in this LLBG are wastes disposed of prior to 1970.

This analysis made use of the unit-release calculations for pre-1970 wastes in the local-scale groundwater model developed for the 200 West Area described in Volume II, Appendix G, Section G.5.1. The underlying assumptions and analysis characteristics associated specifically with the analysis for pre-1970 LLW described in Section G.5.1 provided the basis for the results described here.

### 5.3.7.3 Summary of Results

Based on the estimated inventories of the listed constituents assumed to be disposed of before 1988, summarized in Table 5.16 (Volume II, Appendix G), the analysis showed that potential groundwater quality impacts from such hazardous chemicals would not be expected to be substantial. A screening analysis that considered a combination of contamination mobility (due to sorption) and the potential contaminant degradation (due to biotic degradation and volatilization) reduced the initial number of inorganic and organic constituents with the most significant inventories to a list of three chemicals—chromium, fluoride, and nitrate.

For conditions where all of the estimated hazardous chemical inventories for these constituents are hypothetically emplaced in the 218-W-4B LLBG in the 200 West Area, estimated concentration levels at about 100 meters downgradient of the associated low-level waste management area (for example, LLWMA 3) were found to be below benchmark MCLs for all three chemicals (see Table 5.17).

**Table 5.17.** Estimated Peak Concentrations in Groundwater from Selected Hazardous Chemicals in Waste Hypothetically Disposed of in HSW LLBGs Before 1988

Constituent	Benchmark MCL (mg/L)	Inventory (Kg)	Maximum Concentration <sup>(a)</sup> (mg/L)	Approximate Peak Arrival Time (yrs)
Chromium	0.10	100	0.02	140
Fluoride	4.0	5000 <sup>(b)</sup>	1.0	140
Nitrate	10.0 <sup>(c)</sup>	5000 <sup>(d)</sup>	0.25 <sup>(e)</sup>	140

(a) Results are based on hypothetical disposal of these wastes in LLBG 218-W-4B in the 200 West Area, and concentration levels reflect levels estimated at about 100 m downgradient of the LLWMA 4 boundary.  
 (b) Fluoride mass equivalent in 10,000 kg of sodium fluoride.  
 (c) Benchmark maximum contaminant level for nitrate is expressed as nitrogen.  
 (d) Nitrate mass equivalent for 6,000 kg of sodium nitrate.  
 (e) Concentration expressed as nitrogen.

Actually, waste disposed of before 1988 can be found within multiple burial grounds in the 200 East Area within the 218-E-10 and 218-E-12B LLBGs and in the 200 West Area primarily within the 218-W-4B, 218-W-4C, 218-W-3A, and 218-W-3AE LLBGs. Use of alternative assumptions that would distribute the estimated inventory to multiple LLBGs would result in further reductions in estimated concentration levels at aggregate LLWMA boundaries.

Final closure or remedial investigations of these facilities under RCRA and/or CERCLA guidelines could involve further evaluation of historical waste records, more detailed waste characterization, and a more comprehensive analysis of the potential impacts of the chemical components of these inventories, including potential degradation products.

Results from this qualitative assessment suggest that potential groundwater impacts from the estimated hazardous chemicals inventories hypothetically contained in HSW disposed of before 1988 would not be substantial. This analysis also shows that a substantially larger hazardous chemical inventory would need to be specified for the constituents considered before impacts would approach current benchmark standards.

## 5.4 Geologic Resources

Impacts on geologic resources would result principally from extraction of basalt, sand, gravel, and silt/loam from the Area C borrow pit for use in capping the disposal facilities upon closure. Geologic resources would also be used for construction of trenches and facilities as well as routine maintenance and operations. The amounts of these geologic resources committed in the alternative groups are quantified in Section 5.10. A comparison among the alternative groups of quantities that would be needed with and without needed ILAW resources is summarized in Table 5.18. (As a result of refined calculations of resource needs based on the Technical Information Document [FH 2004], the need for gravel and sand, silt/loam, and basalt for the action alternative groups increased by factors of approximately 1.8, 2.6, and 1.2, respectively, over those reported in the revised draft HSW EIS [DOE 2003].) Impacts on scenic aspects of topography are described in Section 5.12. No other impacts on geologic resources were identified.<sup>(a)</sup>

**Table 5.18.** Comparison of Commitments of Geologic Resources, Millions of m<sup>3</sup>

Waste Volume	Gravel & Sand	Silt/Loam	Basalt	Total
<b>Alternative Group A (without ILAW)</b>				
Hanford Only	0.776	1.90	0.518	3.19
Lower Bound	0.782	1.91	0.521	3.22
Upper Bound	0.828	2.03	0.552	3.41
<b>Alternative Group B (without ILAW)</b>				
Hanford Only	0.881	2.16	0.587	3.62
Lower Bound	0.895	2.19	0.597	3.68
Upper Bound	1.01	2.47	0.673	4.15
<b>Alternative Group C (without ILAW)</b>				
Hanford Only	0.776	1.90	0.518	3.19
Lower Bound	0.782	1.91	0.521	3.22
Upper Bound	0.828	2.03	0.552	3.41
<b>Alternative Group D (without ILAW)</b>				
Hanford Only	0.777–0.821	1.90–2.01	0.518–0.548	3.20–3.38
Lower Bound	0.780–0.824	1.91–2.02	0.520–0.549	3.21–3.39
Upper Bound	0.807–0.850	1.97–2.08	0.538–0.567	3.32–3.50
<b>Alternative Group E (without ILAW)</b>				
Hanford Only	0.772	1.89	0.515	3.18
Lower Bound	0.775	1.90	0.516	3.19
Upper Bound	0.801	1.96	0.534	3.29
<b>No Action Alternative (without ILAW)</b>				
Hanford Only	0.013	0.031	0.008	0.052
Lower Bound	0.013	0.031	0.008	0.052
<b>ILAW</b>				
Vault	2.603 <sup>(b,c)</sup>	NA	NA	NA
Multiple trench	0.770 <sup>(b,d)</sup>	NA	NA	NA
Single trench	0.550 <sup>(b,e)</sup>	NA	NA	NA
(a) Conversion factors: 1 m <sup>3</sup> = about 1.3 yd <sup>3</sup> (b) Total fill (sand, gravel, silt, and rip rap). (c) Applicable to the No Action Alternative. (d) Applicable to Alternative Groups A and B. (e) Applicable to Alternative Groups C, D, and E. NA = not applicable.				

(a) The use of accelerated process lines would not be expected to require any geologic resources, except for, perhaps, minor amounts of gravel when placed temporarily outside of the CWC.

## 5.5 Ecological Resources

Potential impacts on ecological resources as a result of implementing Alternative Groups A, B, C, D<sub>1</sub>, D<sub>2</sub>, D<sub>3</sub>, E<sub>1</sub>, E<sub>2</sub>, and E<sub>3</sub>, and the No Action Alternative are discussed in the following sections. Additional information is provided in Appendix I (see Volume II of this EIS).

Near-term impacts on terrestrial habitats and species relate primarily to surface disturbance associated with use of the existing LLBGs, a proposed Hanford solid waste (HSW) disposal facility near the PUREX Plant, borrow sites in Area C from which capping materials would be obtained, and construction sites for new facilities. The potential for impacts during future waste management operations was determined by field surveys in those areas to identify the presence of sensitive species or habitats that might be affected. Potential long-term impacts on aquatic and riparian organisms would be associated with eventual migration of radionuclides and other hazardous chemicals through the vadose zone to groundwater and on to the Columbia River. (Potential impacts to groundwater are presented in Section 5.3.) Results of the field surveys conducted for this HSW EIS, and the methods used to assess long-term impacts are described further in Volume II, Appendix I.

Areas associated with activities described in the HSW EIS have typically been extensively disturbed, or they consist of relatively low quality habitat. These areas were previously designated for waste management operations and conservation/mining in decisions resulting from the Hanford Comprehensive Land-Use Plan EIS (DOE 1999) in order to protect higher quality resources elsewhere on the Hanford Site. DOE manages potential operational impacts on biological resources in accordance with the Hanford Site Biological Resources Management Plan (BRMaP) (DOE-RL 2001a) and the Hanford Site Biological Resources Mitigation Strategy (BRMiS) (DOE-RL 2003c). These plans were developed following extensive public input and in consultation with regulatory agencies. In general, pre-construction surveys of these areas would be conducted, and any mitigation measures needed to protect resources noted during those surveys would be identified and agreed upon by DOE before construction begins. Potential mitigation measures are discussed further in Section 5.18 and in Volume II, Appendix I.

The 24 Command Fire, a range fire that burned over parts of the Hanford Site in late June–early July 2000, removed large amounts of vegetation in areas of interest, particularly in the western half of the 200 West Area and westward and southward from that area (DOE-RL 2000c). The 24 Command Fire did not reach the 200 West LLBGs or the 200 East Area. The lack of vegetation has resulted in considerable movement of soil by wind since the fire. In the absence of similar fires in the future, ecological resources might begin to restore themselves naturally prior to initiation of some project activities. In the near term, nuisance species such as Russian thistle (*Salsola kali*) and cheatgrass (*Bromus tectorum*) likely are to be particularly abundant.

Impacts on ecological resources are sufficiently similar among the alternative groups in that they would not be expected to be an important discriminator in the selection process. Conclusions regarding potential impacts to terrestrial biota were based on spring/summer field surveys conducted from 1998 to 2003. Conclusions regarding potential impacts to Columbia River aquatic and riparian biota were based on an ecological risk assessment of future contaminant releases.

## 5.5.1 Alternative Group A

### 5.5.1.1 LLBGs

Currently, the 200 East Area LLBGs contain about 106 ha (262 ac) of land, most of which has been surface disturbed. Approximately 64 ha (158 ac) of this area already have been used for waste disposal. In Alternative Group A, the disposal area would be expanded from about 64 ha to about 66 ha (163 ac) for the Hanford Only and Lower Bound waste volumes and to about 70 ha (173 ac) for the Upper Bound waste volume.

Cheatgrass and Sandberg's bluegrass (*Poa sandbergii*) dominate approximately two-thirds of the 200 East Area LLBGs. The planted perennial, crested wheatgrass (*Agropyron cristatum*), dominates the other one-third. The 200 East Area LLBGs receive regular herbicide applications and thus have limited habitat value for native species. Consequently, continued use of these LLBGs, or new disturbance of the extant plant communities within them via expansion of the disposal area, would not result in the loss of any State of Washington-designated priority habitat.

Several plant species of concern have been noted within the 200 East Area LLBGs. The most notable of these is Piper's daisy (*Erigeron piperianus*), listed by Washington State as a Sensitive species (a taxon that is vulnerable or declining and could become endangered or threatened in Washington without active management or removal of threats). This species was noted on the 218-E-10 and 218-E-12B LLBGs during spring 1999 but not in spring 2000, 2001, or 2002. Piper's daisy populations on these LLBGs have been reduced or eliminated, likely as a result of regular herbicide applications. If herbicide spraying were to cease, these populations could regenerate from buried seed and be disturbed by waste management activities. However, continuing maintenance of the burial grounds is necessary to prevent the growth of deep-rooted species that could transfer contaminants to the surface before final closure. DOE's biological control program is discussed further in Volume II, Appendix I, and in Section 5.11.2.2.4.

The other plant species of concern observed within the 218-E-10 and 218-E-12B LLBGs is crouching milkvetch (*Astragalus succumbens*), a Washington State Watch List species (plant taxon that is of concern but is considered to be more abundant and/or less threatened in Washington than previously assumed). This species was observed in spring 2000, 2001, and 2002 within Trench 94 in the 218-E-12B LLBG and on the northeast side of the 218-E-10 LLBG. Because crouching milkvetch is relatively common on the Central Plateau, disturbance of those individuals on the 218-E-12B and 218-E-10 LLBGs likely would not adversely affect the overall local population.

The 200 West Area LLBGs contain about 319 ha (788 ac), most of which has been surface disturbed. About 67 ha (166 ac) already have been used for burial of solid waste. In Alternative Group A, the disposal area would be expanded from about 67 ha to about 70 ha (173 ac) for the Hanford Only waste volume, to 71 ha (175 ac) for the Lower Bound waste volume, and to 76 ha (188 ac) for the Upper Bound waste volume.

Virtually all the 200 West Area LLBGs are sparsely colonized by cheatgrass, Russian thistle, and crested wheatgrass. These LLBGs also receive regular herbicide applications and thus have limited

habitat value for native species. Consequently, continued use of these LLBGs, or new disturbance of the extant plant communities within them via expansion of the disposal area, would not result in the loss of any Washington State-designated priority habitat.

The undeveloped southeastern portion of the 218-W-4C LLBG in the 200 West Area is dominated by mature shrub-steppe, designated a Washington State priority habitat. However, because the 5 ha (12 ac) that currently are being used would not be expanded, no impacts to shrub-steppe are expected.

One plant species of concern has been observed within some of the 200 West LLBGs—stalked-pod milkvetch (*Astragalus sclerocarpus*), a Washington State Watch List species. Stalked-pod milkvetch was observed in spring 1998, 1999, 2000, 2001, and 2002 at the extreme western edge of the 218-W-5 LLBG and within the undeveloped portion of the 218-W-4C LLBG. Because Stalked-pod milkvetch is relatively common on the Central Plateau (Sackschewsky and Downs 2001), disturbance of those individuals on the 218-W-5 and 218-W-4C LLBGs likely would not adversely affect the overall local population.

Wildlife that could be affected by disturbance of the 200 East and 200 West LLBGs includes the mule deer (*Odocoileus hemionus*), Great Basin pocket mouse (*Perognathus parvus*), side-blotched lizard (*Uta stansburiana*), and several migratory bird species. Ground-nesting birds that have been observed and that may nest within the 200 East and 200 West LLBGs include the horned lark (*Eremophila alpestris*), killdeer (*Charadrius vociferous*), long-billed curlew (*Numenius americanus*), and Western meadowlark (*Sturnella neglecta*). If excavation activities were to occur during the nesting season, generally March through July, they could destroy eggs or young birds and temporarily displace nesting individuals into other areas of the Hanford Site. As noted previously in this section and in Volume II, Appendix I, DOE would typically take measures to avoid or mitigate these potential consequences (such as limiting major excavation during the nesting season) before proceeding with construction.

#### **5.5.1.2 HSW Disposal Facility Near the PUREX Plant in the 200 East Area**

Currently, the proposed HSW disposal facility near the PUREX Plant contains about 41 ha (101 ac), of which none has been cleared or used for burial of solid waste. The overstory in this area is dominated by sagebrush; the understory is dominated by cheatgrass and Sandberg's bluegrass. Development of the new HSW disposal facility for ILAW near the PUREX Plant would result in the loss of 32 ha (79 ac) (all waste volumes) of shrub-steppe. No plant species of concern were observed on the disposal area near the PUREX Plant during the summer field survey of 2002.

Wildlife that could be affected by disturbance of the new HSW disposal facility near the PUREX Plant includes the black-tailed jackrabbit (*Lepus californicus*), mule deer, coyote (*Canis latrans*), and Northern pocket gopher (*Thomomys talpoides*), as well as several migratory bird species. Shrub- and ground-nesting birds that have been observed and that likely nest within the disposal area near the PUREX Plant include the sage sparrow (*Amphispiza belli*) and Western meadowlark, respectively. If excavation activities were to occur during the nesting season, generally March through July, they could destroy eggs or young birds and temporarily displace nesting individuals into other areas of the Hanford Site. As noted previously in this section and in Volume II, Appendix I, DOE would typically take

measures to avoid or mitigate these potential consequences (such as limiting major excavation during the nesting season) before proceeding with construction.

The black-tailed jackrabbit and sage sparrow are considered Washington State Candidate species (species that the Washington Department of Fish and Wildlife will review for possible listing as state-endangered, -threatened, or -sensitive). The distribution of the black-tailed jackrabbit and sage sparrow within Washington is limited mostly to the Columbia Basin. Both species have a strong affinity for sagebrush habitat. The area of sagebrush habitat to be disturbed by waste management activities is small relative to the overall area of such habitat on the Hanford Site and in the Columbia Basin. Consequently, removal of sagebrush within the proposed HSW disposal facility near the PUREX Plant would have, at most, a small impact on populations of these species within the Columbia Basin.

### **5.5.1.3 Facilities**

The CWC and WRAP lie in an industrialized area of about 90 ha (222 ac). No new impacts are expected to result from continued operation of these facilities or installation and operation of APLs to facilitate expedited processing of TRU waste.

The T Plant Complex, which covers about 8 ha (20 ac), also lies within an industrial area and provides habitat only for those birds that use the exterior of these buildings. Because modifications of the T Plant Complex would be carried out within the T Plant, no new impacts are expected.

The 200 Area Effluent Treatment Facility (ETF) and Liquid Effluent Retention Facility (LERF) lie in an industrialized area of about 65 ha (161 ac). No new impacts are expected to result from continued operation of these facilities.

### **5.5.1.4 Borrow Pit**

Basalt, gravel, and silt/loam for use in capping the HSW disposal facilities would be obtained from borrow pits in Area C, an area of about 926 ha (2288 ac). This area also was burned in the 24 Command Fire; however, some of the pre-fire shrub and understory vegetation survived, so the underlying soil surface has not been as severely affected by wind erosion. The associated stockpile area east of SR 240 and the area designated for the conveyance roads to the 200 Areas were burned severely in the 24 Command Fire, removing all the vegetation.

Excavation of borrow materials would require about 69 ha (170 ac), 70 ha (173 ac), and 73 ha (180 ac) for the Hanford Only, Lower Bound, and Upper Bound waste volumes, respectively. Impacts to habitats and species would depend largely on the locations of borrow pits within Area C. The locations of these areas of disturbance have not yet been determined.

Three habitats of concern within Area C may be affected by the excavation of borrow materials, depending on the location of the borrow pits. These three habitats are designated element occurrences of plant community types by the State of Washington Natural Heritage Program (NHP). An element occurrence of a plant community type is one that meets the minimum standards set by NHP for ecological



condition, size, and the surrounding landscape. Element occurrences are generally considered to be of substantial conservation value from a state and/or regional perspective. The largest of these is a cheatgrass/needle-and-thread grass/Indian ricegrass community, an element occurrence of the bitterbrush/Indian ricegrass sand dune complex community type, consisting of 97 ha (241 ac). The other two communities are much smaller. The needle-and-thread grass/cheatgrass community, an element occurrence of the sagebrush/needle-and-thread grass community type, consists of 5 ha (12 ac). The Sandberg's bluegrass/cheatgrass community, an element occurrence of the big sagebrush/bluebunch wheatgrass community type, consists of 1.5 ha (4 ac). These and other habitats that could be disturbed or eliminated by excavation of borrow materials within Area C are discussed in detail in Volume II, Appendix I. As noted previously in this section and in Volume II, Appendix I, DOE typically would establish measures to avoid or mitigate these potential consequences before proceeding with construction.

The only plant species of concern observed in Area C during the summer 2002 field survey were purple mat (*Nama densum* var. *parviflorum*), crouching milkvetch, and stalked-pod milkvetch. Purple mat is a Washington State Review 1 species (plant taxon of potential concern that is in need of additional field work before a status can be assigned). Purple mat occurs occasionally throughout central Hanford, and crouching milkvetch and stalked-pod milkvetch are relatively common on the Central Plateau. Consequently, disturbance of the individual plants located in Area C likely would not adversely affect the overall local populations of these species.

Wildlife that could be impacted by disturbance of Area C includes the badger (*Taxidea taxus*), coyote, elk (*Cervus elaphus*), mule deer, northern pocket gopher, and several migratory birds. No wildlife species of concern were observed in Area C. However, a herd of several hundred elk currently uses the Fitzner/Eberhardt Arid Lands Ecology (ALE) Reserve and surrounding private lands. Elk have been observed using Area C for foraging and loafing. Calving generally occurs at the upper elevations of Rattlesnake Mountain. Blasting and use of heavy equipment to remove borrow materials from Area C, particularly if conducted during the winter months, might disturb elk and displace some animals into adjacent areas. However, because Area C is only a small portion of their overall range and is not known to be particularly important for either overwintering or calving, the effect on the population likely is to be minimal.

The stockpile and conveyance road area currently supports Russian thistle, cheatgrass, and dune scurfpea (*Psoralea lanceolata*). The only plant species of concern observed in this area during the summer 2002 field survey was stalked-pod milkvetch. Because Stalked-pod milkvetch is relatively common on the Central Plateau (Sackschewsky and Downs 2001), disturbance of the individual plants in the stockpile and conveyance road area likely would not adversely affect the overall local population of this species.

The black-tailed jackrabbit is the only wildlife species of concern observed within the stockpile and conveyance road area. Other wildlife species observed include the coyote. Some local jackrabbit mortalities may result from increased vehicular traffic. However, because this area is relatively small and

because sagebrush recovery in the area would be expected to be minimal before the start of new construction, the impact of its disturbance on the black-tailed jackrabbit population within the Columbia Basin likely would be minimal.

Ground-nesting birds that have been observed and that may nest in Area C and within the stockpile and conveyance road area include the horned lark and Western meadowlark. If excavation activities were to occur during the nesting season, generally March through July, they could destroy eggs or young birds and temporarily displace nesting individuals into other areas of the Hanford Site. As noted previously in this section and in Volume II, Appendix I, DOE would typically take measures to avoid or mitigate these potential consequences (such as limiting major excavation during the nesting season) before proceeding with construction.

## **5.5.2 Alternative Group B**

### **5.5.2.1 LLBGs**

The impacts on ecological resources in the 200 East and 200 West LLBGs in Alternative Group B would be essentially the same as for Alternative Group A, although the scale of disturbance would be somewhat larger. The area occupied by LLW and MLLW in Alternative Group B would increase by about 15 to 30 percent, depending on waste volume, over that specified in Alternative Group A. Because this expanded area still would be within the boundaries of the existing 200 East and 200 West LLBGs, which have limited habitat value for native species due to regular herbicide applications, any additional impacts on ecological resources are expected to be minimal.

### **5.5.2.2 Facilities**

Impacts from the operation of the CWC, WRAP, APLs, ETF, T Plant Complex, and LERF would be essentially the same as those described for Alternative Group A.

The new waste processing facility would be located just west of WRAP. Constructing this facility would disturb about 4 ha (10 ac) of habitat. This area was burned severely in the 24 Command Fire and continues to be severely eroded by wind. The dominant plant species in the area is bur ragweed (*Ambrosia acanthocarpa*), a native annual. The only wildlife observed in this area was the coyote. No plant or wildlife species of concern occur in the area, except crouching milkvetch. Because crouching milkvetch is relatively common on the Central Plateau, disturbance of individual plants in this area likely would not adversely affect the overall local population of this species.

The CWC expansion area is located north of 16th Street and west of Dayton Avenue to the north-south line of the CWC. This area was burned in the 24 Command Fire and continues to be severely eroded by wind. Disposal of ILAW would disturb about 26 ha (64 ac) of habitat in this area. The dominant plant species in the CWC expansion area is Russian thistle. Stalked-pod milkvetch and purple mat were the only plant species of concern observed in the CWC expansion area. Because purple mat occurs occasionally throughout central Hanford and Stalked-pod milkvetch is relatively common on the

Central Plateau (Sackschewsky and Downs 2001), disturbance of the individual plants of these two species located in the CWC expansion area likely would not adversely affect the overall local populations.

The only wildlife species observed in the CWC expansion area was the coyote. Ground-nesting birds that were observed and may nest within the CWC expansion area include the horned lark and Western meadowlark. If excavation activities were to occur during the nesting season, generally March through July, they could destroy eggs or young birds and temporarily displace nesting individuals into other areas of the Hanford Site. As noted previously in this section and in Volume II, Appendix I, DOE would typically take measures to avoid or mitigate these potential consequences (such as limiting major excavation during the nesting season) before proceeding with construction. No wildlife species of concern were observed in the CWC expansion area.

Although there are no plans at present to use the 218-W-5 Expansion Area, it could be used in the future. The dominant plant species in the 218-W-5 Expansion Area are Sandberg's bluegrass, cheatgrass, Indian ricegrass, and Russian thistle. The only plant species of concern observed in the 218-W-5 Expansion Area were crouching milkvetch, stalked-pod milkvetch, and purple mat. Because purple mat occurs occasionally throughout central Hanford, and crouching milkvetch and stalked-pod milkvetch are relatively common on the Central Plateau, disturbance of the individual plants of these three species located in the 218-W-5 Expansion Area likely would not adversely affect the overall local populations.

Wildlife that could be impacted by disturbance of the 218-W-5 Expansion Area include the badger, coyote, Great Basin pocket mouse, and mule deer. Ground-nesting birds that were observed and may nest within the 218-W-5 Expansion Area include the horned lark and Western meadowlark. If excavation activities were to occur during the nesting season, generally March through July, they could destroy eggs or young birds and temporarily displace nesting individuals into other areas of the Hanford Site. As noted previously in this section and in Volume II, Appendix I, DOE would typically take measures to avoid or mitigate these potential consequences (such as limiting major excavation during the nesting season) before proceeding with construction. No wildlife species of concern were observed in the 218-W-5 Expansion Area.

### **5.5.2.3 Borrow Pit**

Impacts associated with use of Area C in Alternative Group B would be slightly greater compared with those in Alternative Group A because the scale of disturbance would be somewhat larger. The area to be excavated in Alternative Group B would be about 10 to 20 percent greater, depending on waste volume, over that specified in Alternative Group A. The area of the associated stockpile and conveyance road would remain the same in Alternative Group B as in Alternative Group A.

### **5.5.3 Alternative Group C**

#### **5.5.3.1 LLBGs**

The impacts on ecological resources in Alternative Group C would be the same as those for Alternative Group A because the areas occupied by LLW and MLLW in Alternative Group C would be the same as those in Alternative Group A.

#### **5.5.3.2 HSW Disposal Facility near the PUREX Plant in the 200 East Area**

The impacts on ecological resources in Alternative Group C would be substantially smaller compared with those in Alternative Group A; the scale of disturbance would be reduced by about 55 percent for all waste volumes because of the reduced area required for ILAW disposal.

#### **5.5.3.3 Facilities**

Impacts from the operation of the CWC, WRAP, APLs, ETF, LERF, and the T Plant Complex would be essentially the same as those described for Alternative Group A.

#### **5.5.3.4 Borrow Pit**

Impacts associated with use of Area C in Alternative Group C would be slightly smaller compared with those in Alternative Group A because the scale of disturbance would be somewhat smaller. The area to be excavated in Alternative Group C would be about 10 percent less for all waste volumes than that specified in Alternative Group A. The area of the associated stockpile and conveyance road would remain the same in Alternative Group C as in Alternative Group A.

### **5.5.4 Alternative Group D<sub>1</sub>**

#### **5.5.4.1 LLBGs**

Because the 200 East and 200 West LLBGs have limited habitat value for native species due to regular herbicide applications, the impacts on ecological resources in Alternative Group D<sub>1</sub> would be essentially the same as for Alternative Group A, although the scale of disturbance would be somewhat smaller. The LLW and MLLW for all waste volumes in Alternative Group D<sub>1</sub> would use only the areas that already have been used for disposal of solid waste (64 ha [158 ac] in the 200 East LLBGs and 67 ha [166 ac] in the 200 West LLBGs), representing about 5 to 15 percent less area disturbed, depending on waste volume, than Alternative Group A.

#### **5.5.4.2 HSW Disposal Facility near the PUREX Plant in the 200 East Area**

The impacts on ecological resources in Alternative Group D<sub>1</sub> would be smaller than those in Alternative Group A. The scale of disturbance in Alternative Group D<sub>1</sub> would be smaller than that of Alternative Group A by about 25 percent for the Upper Bound waste volume but by about 40 percent for the Hanford Only and Lower Bound waste volumes because of the reduced area required for ILAW disposal.

#### **5.5.4.3 Facilities**

Impacts from the operation of the CWC, WRAP, APLs, ETF, LERF, and the T Plant Complex would be essentially the same as those described for Alternative Group A.

#### **5.5.4.4 Borrow Pit**

Impacts associated with use of Area C in Alternative Group D<sub>1</sub> would be slightly smaller than those in Alternative Group A because the scale of disturbance would be somewhat smaller. The area to be excavated in Alternative Group D<sub>1</sub> would be about 10 percent less for all waste volumes than that specified in Alternative Group A. The area of the associated stockpile and conveyance road would remain the same in Alternative Group D<sub>1</sub> as in Alternative Group A.

### **5.5.5 Alternative Group D<sub>2</sub>**

#### **5.5.5.1 LLBGs**

Because the 200 West LLBGs have limited habitat value for native species due to regular herbicide applications, the impacts on ecological resources in Alternative Group D<sub>2</sub> would be essentially the same as those in Alternative Group A, although the scale of disturbance would be somewhat smaller. The LLW and MLLW for all waste volumes in Alternative Group D<sub>2</sub> would use only the areas that already have been used for disposal of solid waste (67 ha [166 ac]), representing about 5 to 10 percent less area of disturbance, depending on waste volume, than Alternative Group A.

The impacts on ecological resources in the 200 East LLBGs in Alternative Group D<sub>2</sub> would be essentially the same as those for Alternative Group A, although the scale of disturbance would be somewhat larger due to ILAW disposal. The area occupied by LLW, MLLW, and ILAW in Alternative Group D<sub>2</sub> would be about 25 percent less for all waste volumes over that specified for LLW and MLLW in Alternative Group A. Because this expanded area still would be within the boundaries of the existing 200 East LLBGs, which have limited habitat value for native species due to regular herbicide applications, any additional impacts on ecological resources are expected to be minimal.

#### **5.5.5.2 Facilities**

Impacts from the operation of the CWC, WRAP, APLs, ETF, LERF, and the T Plant Complex would be essentially the same as those described for Alternative Group A.

### 5.5.5.3 Borrow Pit

Impacts associated with use of Area C in Alternative Group D<sub>2</sub> would be slightly less than those in Alternative Group A because the scale of disturbance would be somewhat smaller. The area to be excavated in Alternative Group D<sub>2</sub> would be about 10 percent less for all waste volumes than that specified in Alternative Group A. The area of the associated stockpile and conveyance road would remain the same in Alternative Group D<sub>2</sub> as in Alternative Group A.

## 5.5.6 Alternative Group D<sub>3</sub>

### 5.5.6.1 LLBGs

Because the 200 East and 200 West LLBGs have limited habitat value for native species due to regular herbicide applications, the impacts on ecological resources in Alternative Group D<sub>3</sub> would be essentially the same as those for Alternative Group A, although the scale of disturbance would be somewhat smaller. The LLW and MLLW for all waste volumes in Alternative Group D<sub>3</sub> would use only the areas that already have been used for disposal of solid waste (64 ha [158 ac] in the 200 East LLBGs and 67 ha [166 ac] in the 200 West LLBGs), representing about 5 to 15 percent less area disturbed, depending on waste volume, than Alternative Group A.

### 5.5.6.2 ERDF

About 19 to 20 ha (47 to 49 ac) (Hanford Only and Lower Bound waste volumes) to 25 ha (62 ac) (Upper Bound waste volume) at ERDF would be cleared for disposal of ILAW, which most likely would be located just east of the existing ERDF disposal cells. Therefore, the area within 1 km (0.62 mi) of the existing ERDF disposal cells was surveyed in spring 2003. This site and some of the surrounding area, including the area surveyed, was burned in the 24 Command Fire. Currently, vegetation in the surveyed area consists primarily of cheatgrass. The only observed plant species of concern was stalked-pod milkvetch. Stalked-pod milkvetch is relatively common on the Central Plateau (Sackschewsky and Downs 2001). Therefore, disturbance of those individuals in the surveyed area likely would not adversely affect the local population.

Wildlife observed within 1 km of the current ERDF eastern boundary includes the coyote, northern pocket gopher, side-blotched lizard, and several migratory bird species—the horned lark, Western meadowlark, and loggerhead shrike (*Lanius ludovicianus*). The latter species is a Washington State Candidate species and a Federal Species of Concern (species whose conservation standing is of concern to the U.S. Fish and Wildlife Service but for which status information still is needed).

The horned lark and Western meadowlark are ground-nesting species. The same temporal restrictions as set forth above apply for conducting ground-disturbing activities outside the nesting season to protect the nests, eggs, and young of these species in this area. The loggerhead shrike generally nests in shrubs and trees. There are no trees in the surveyed area and shrubs are very scarce. Therefore, it is unlikely that the shrikes observed during the spring 2003 survey were nesting in the surveyed area.

### **5.5.6.3 Facilities**

Impacts from the operation of the CWC, WRAP, APLs, ETF, LERF, and the T Plant Complex would be essentially the same as those described for Alternative Group A.

### **5.5.6.4 Borrow Pit**

Impacts associated with use of Area C in Alternative Group D<sub>3</sub> would be slightly less than those in Alternative Group A because the scale of disturbance would be somewhat smaller. The area to be excavated in Alternative Group D<sub>3</sub> would be about 10 percent less for all waste volumes than that specified in Alternative Group A. The area of the associated stockpile and conveyance road would remain the same in Alternative Group D<sub>3</sub> as in Alternative Group A.

## **5.5.7 Alternative Group E<sub>1</sub>**

### **5.5.7.1 LLBGs**

Because the 200 West LLBGs have limited habitat value for native species due to regular herbicide applications, the impacts on ecological resources in Alternative Group E<sub>1</sub> would be essentially the same as in Alternative Group A, although the scale of disturbance would be somewhat smaller. The LLW and MLLW for all waste volumes in Alternative Group E<sub>1</sub> would use only the areas that already have been used for disposal of solid waste (67 ha [166 ac]), representing about 5 to 10 percent less area disturbed, depending on waste volume, than Alternative Group A.

Because the 200 East LLBGs have limited habitat value for native species due to regular herbicide applications, the impacts on ecological resources in Alternative Group E<sub>1</sub> would be essentially the same as in Alternative Group A, although the scale of disturbance would be somewhat larger. The area occupied by LLW and MLLW for all waste volumes in Alternative Group E<sub>1</sub> would be about 5 percent greater than that specified in Alternative Group A.

### **5.5.7.2 ERDF**

Impacts on ecological resources in Alternative Group E<sub>1</sub> would be smaller than those in Alternative Group D<sub>3</sub>. The scale of disturbance in Alternative Group E<sub>1</sub> would be less than that in Alternative Group D<sub>3</sub> by about 30 percent for the Hanford Only and Lower Bound waste volumes but by about 45 percent for the Upper Bound waste volume because of the smaller area required for ILAW disposal.

### **5.5.7.3 Facilities**

Impacts from the operation of the CWC, WRAP, APLs, ETF, LERF, and the T Plant Complex would be essentially the same as those described for Alternative Group A.

#### **5.5.7.4 Borrow Pit**

Impacts associated with use of Area C in Alternative Group E<sub>1</sub> would be less than those in Alternative Group A because the scale of disturbance would be somewhat smaller. The area to be excavated in Alternative Group E<sub>1</sub> would be about 10 percent less for all waste volumes than that specified in Alternative Group A. The area of the associated stockpile and conveyance road would remain the same in Alternative Group E<sub>1</sub> as in Alternative Group A.

### **5.5.8 Alternative Group E<sub>2</sub>**

#### **5.5.8.1 LLBGs**

Because the 200 East and 200 West LLBGs have limited habitat value for native species due to regular herbicide applications, the impacts on ecological resources in Alternative Group E<sub>2</sub> would be essentially the same as those in Alternative Group A, although the scale of disturbance would be somewhat smaller. The LLW and MLLW for all waste volumes in Alternative Group E<sub>2</sub> would use only the areas that already have been used for disposal of solid waste (64 ha [158 ac] in the 200 East LLBGs and 67 ha [166 ac] in the 200 West LLBGs), representing about 5 to 15 percent less area of disturbance, depending on waste volume, than Alternative Group A.

#### **5.5.8.2 ERDF**

The impacts on ecological resources in Alternative Group E<sub>2</sub> would be smaller than those in Alternative Group D<sub>3</sub>. The scale of disturbance in Alternative Group E<sub>1</sub> would be less than that in Alternative Group D<sub>3</sub> by about 30 percent for the Hanford Only and Lower Bound waste volumes but by about 45 percent for the Upper Bound waste volume because of the smaller area required for ILAW disposal.

#### **5.5.8.3 HSW Disposal Facility near the PUREX Plant in the 200 East Area**

The impacts on ecological resources in Alternative Group E<sub>2</sub> would be much smaller compared with those in Alternative Group A; the scale of disturbance would be about 65 percent less for the Upper Bound waste volume and about 85 percent less for the Hanford Only and Lower Bound waste volumes because of the smaller area required for ILAW disposal.

#### **5.5.8.4 Facilities**

Impacts from the operation of the CWC, WRAP, APLs, ETF, LERF, and the T Plant Complex would be essentially the same as those described for Alternative Group A.

#### **5.5.8.5 Borrow Pit**

Impacts associated with use of Area C in Alternative Group E<sub>2</sub> would be slightly smaller than those in Alternative Group A because the scale of disturbance would be somewhat smaller. The area to be excavated



in Alternative Group E<sub>2</sub> would be about 10 percent less for all waste volumes than that specified in Alternative Group A. The area of the associated stockpile and conveyance road would remain the same in Alternative Group E<sub>2</sub> as in Alternative Group A.

### **5.5.9 Alternative Group E<sub>3</sub>**

#### **5.5.9.1 LLBGs**

Because the 200 East and 200 West LLBGs have limited habitat value for native species due to regular herbicide applications, the impacts on ecological resources in Alternative Group E<sub>3</sub> would be essentially the same as those in Alternative Group A, although the scale of disturbance would be somewhat smaller. The LLW and MLLW for all waste volumes in Alternative Group E<sub>3</sub> would use only the areas that already have been used for disposal of solid waste (64 ha [158 ac] in the 200 East LLBGs and 67 ha [166 ac] in the 200 West LLBGs), representing about 5 to 15 percent less area disturbed, depending on waste volume, than Alternative Group A.

#### **5.5.9.2 ERDF**

The impacts on ecological resources in Alternative Group E<sub>3</sub> would be much smaller compared with those in Alternative Group A because the scale of disturbance would be about 60 percent less for the Upper Bound waste volume and about 75 percent less for the Hanford Only and Lower Bound waste volumes.

#### **5.5.9.3 HSW Disposal Facility near the PUREX Plant in the 200 East Area**

The impacts on ecological resources in Alternative Group E<sub>3</sub> would be substantially smaller compared with those in Alternative Group A; the scale of disturbance would be about 55 percent less for all waste volumes because of the smaller area required for ILAW disposal.

#### **5.5.9.4 Facilities**

Impacts from the operation of the CWC, WRAP, APLs, ETF, LERF, and the T Plant Complex would be essentially the same as those described for Alternative Group A.

#### **5.5.9.5 Borrow Pit**

Impacts associated with use of Area C in Alternative Group E<sub>3</sub> would be slightly smaller than those in Alternative Group A because the scale of disturbance would be somewhat smaller. The area to be excavated in Alternative Group E<sub>3</sub> would be about 10 percent less for all waste volumes from that specified in Alternative Group A. The area of the associated stockpile and conveyance road would remain the same in Alternative Group E<sub>3</sub> as in Alternative Group A.

## **5.5.10 No Action Alternative**

### **5.5.10.1 LLBGs**

The impacts on ecological resources in the 200 West LLBGs in the No Action Alternative would be essentially the same as those in Alternative Group A, although the scale of disturbance would be somewhat larger. The area occupied by LLW and MLLW in the No Action Alternative would be about 13 percent greater for the Hanford Only and Lower Bound waste volumes over that specified in Alternative Group A. Because this expanded area still would be within the boundaries of the existing 200 West LLBGs, which have limited habitat value for native species due to regular herbicide applications, any additional impacts on ecological resources would be expected to be minimal.

Because the 200 East LLBGs have limited habitat value for native species due to regular herbicide applications, the impacts on ecological resources in the No Action Alternative would be essentially the same as those in Alternative Group A, although the scale of disturbance would be somewhat larger. The area occupied by LLW and MLLW for the Hanford Only and Lower Bound waste volumes in the No Action Alternative would be about 3 percent larger than that specified in Alternative Group A.

### **5.5.10.2 HSW Disposal Facility near the PUREX Plant in the 200 East Area**

Impacts on ecological resources in the No Action Alternative would be much smaller compared with those in Alternative Group A. The scale of disturbance would be about 70 percent less for the Hanford Only and Lower Bound waste volumes because of the smaller area required for ILAW disposal.

### **5.5.10.3 Facilities**

Impacts from the operation of the CWC, WRAP, APLs, T Plant Complex, ETF, and LERF would be essentially the same as those described for Alternative Group A.

The CWC expansion in the No Action Alternative is intended for the purpose of facilities construction, whereas the CWC expansion in Alternative Group B is intended for the purpose of ILAW disposal. These two CWC expansion areas occur at different but nearby locations. Both locations were burned in the 24 Command Fire, and the ecological resources at both sites are essentially the same.

Consequently, the impacts on ecological resources in the CWC expansion area for the Hanford Only waste volume for the No Action Alternative would be essentially the same as those in Alternative Group B, although the scale of disturbance would be about 10 percent smaller.

Likewise, the impacts on ecological resources in the CWC expansion area for the Lower Bound waste volume for the No Action Alternative would be essentially the same as those in Alternative Group B, although the scale of disturbance would be about 15 percent larger.

#### **5.5.10.4 Borrow Pit**

Impacts associated with use of Area C in the No Action Alternative would be very small compared with those in Alternative Group A because the scale of disturbance would be about 80 percent less for the Hanford Only and Lower Bound waste volumes. The area of the associated stockpile and conveyance road would remain the same in the No Action Alternative as in Alternative Group A.

#### **5.5.11 Microbiotic Crusts**

Disruption of microbiotic crusts (cryptogams) may result in decreased diversity of microbiota, soil nutrients, and organic matter (Belnap and Harper 1995; Belnap et al. 2001). The 24 Command Fire during summer 2000 intensely burned the soil surface in areas (outside the LLBGs) that would be disturbed by new construction as described in the HSW EIS (that is, Area C and the associated stockpile and conveyance road areas, the two CWC expansion areas identified for facilities construction and ILAW disposal, and the area identified for the new waste processing facility). This undoubtedly resulted in the destruction of soil microbiota, facilitating the severe wind erosion experienced in these areas (Becker and Sackschewsky 2001; Sackschewsky and Becker 2001). Recovery of microbiotic crusts following disturbance is generally a slow process. For example, in burned areas on the ALE Reserve, soil algae recovery took place during the winter months of the second year following the fire of 1984 (Johansen et al. 1993). The recovery time required by soil microbiota following construction is no exception.

Although microbiotic crusts may tolerate shallow burial, deep burial such as would result from construction described in the HSW EIS will kill crusts (Shields et al. 1957). Recolonization of Area C and the associated stockpile and conveyance road area, the two CWC expansion areas identified for facilities construction and ILAW disposal, and the area identified for the new waste processing facility undoubtedly would require several years following construction, the speed of which may depend largely on the availability of nearby sources of cryptogams (Belnap 1993). Consequently, a temporary loss of benefits derived from microbiotic crusts would ensue.

#### **5.5.12 Threatened or Endangered Species**

In November 1998, DOE initiated consultation with the National Marine Fisheries Service (NMFS) and the U.S. Fish and Wildlife Service (FWS) regarding the LLBGs. At that time, DOE requested a listing of federally protected species that might occur in these and other areas potentially disturbed by waste management activities. The FWS response, which identified species protected under the Endangered Species Act (ESA), contained no species known to occur in the LLBGs and other project areas covered under the 1998 consultation (see Volume II, Appendix I, Attachment B). In addition, these same areas have been surveyed annually under the DOE Ecological Compliance Assessment Project (DOE-RL 1995), and no federally protected species have been documented (see Volume II, Appendix I of the HSW EIS).

However, the footprint of potential surface disturbance since has expanded beyond that of 1998 (for example, addition of Area C). Consequently, DOE re-initiated consultation with the NMFS and FWS in March 2002 (see Volume II, Appendix I, Attachment B), again requesting a listing of federally protected

species that could occur in all areas potentially disturbed by waste management activities. The NMFS responded by telephone on April 26, 2002, and provided a web site (<http://www.nwr.noaa.gov/1habcon/habweb/listnwr.htm>) containing currently listed threatened and endangered species in the Pacific Northwest (see Volume II, Appendix I, Attachment B). The FWS responded in April 2002 by letter containing currently listed threatened and endangered species that may be present near the proposed project site in Benton County (see Volume II, Appendix I, Attachment B). The NMFS- and FWS-listed threatened and endangered species known to occur on the Hanford Site are tabulated in Section 4.6.4.

In February 2003, DOE again requested from the FWS a listing of federally protected species that could occur in all areas potentially disturbed by waste management activities (Volume II, Appendix I, Attachment B). DOE revisited the NMFS web site noted above in March 2003. The FWS responded by letter in February 2003 (see Volume II, Appendix I, Attachment B). The result of revisiting the NMFS web site also is provided in Attachment B of Volume II, Appendix I.

The terrestrial habitats that potentially could be disturbed have been surveyed previously, and none of the federally listed threatened or endangered species tabulated in Section 4.6.4 were observed (see Volume II, Appendix I). The aquatic endangered species that potentially could be affected are the upper Columbia River spring-run evolutionarily significant unit (ESU) of Chinook salmon (*Oncorhynchus tshawytscha*) and the upper Columbia River ESU of steelhead (*Oncorhynchus mykiss*). Spring Chinook salmon do not spawn within the Hanford Reach; instead, the reach is used by in-migrating salmon as a passage corridor and by out-migrating juvenile salmon as a corridor and for interim feeding. Steelhead are present in the Hanford Reach all year, with most adults residing from 6 to 8 months. Juveniles usually spend 1 to 3 years in freshwater before migrating downstream to the ocean. It has long been believed that limited spawning occurs within the Hanford Reach (DOE-RL 2000b). This was verified in February 2003 when at least two redds were observed near the shoreline of the 300 Area (Lohn 2004, Sackschewsky et al. 2003 [see Volume II, Appendix O]). The risk of future adverse effects to these two species posed by contaminants migrating through the vadose zone and into groundwater, and ultimately entering the Columbia River, is expected to be negligible (see Volume II, Appendix I).

The threatened bull trout (*Salvelinus confluentus*) spends the majority of its life cycle in Columbia River tributaries, of which the Hanford Reach has none. The bull trout has been observed only a very few times in the Hanford Reach within the last 30 years. Consequently, the probability that this species could be exposed to contaminants reaching the Columbia River would be near zero. In addition, the risk of future adverse effects to the bull trout posed by contaminants migrating through the vadose zone and into the groundwater, and, ultimately, entering the Columbia River, would be negligible (see Volume II, Appendix I). Critical habitat for the bull trout is proposed for the mainstem Columbia River, including the Hanford Reach. No actions that would physically modify proposed critical habitat for this species would occur under any of the alternative groups of the HSW EIS. Further, because the species occurs so rarely in the Hanford Reach, contaminants reaching the Columbia River would not be expected to affect its use of proposed critical habitat.

### 5.5.13 Potential Impacts on Columbia River Aquatic and Riparian Biota in the Long Term

Leaching of radionuclides and other hazardous chemicals from the waste via infiltrating precipitation would eventually result in small quantities of long-lived mobile radionuclides reaching the Columbia River. The following is a general discussion of the risk of future adverse impacts to Columbia River aquatic and riparian biota posed by these contaminant releases within 10,000 years of 2046, and of risk as a discriminator among the alternative groups.

Risk of radiological impacts is not an important discriminator among the alternative groups within 0 to 2500 years following 2046 (see Volume II, Appendix I, Section I.3.4). However, in the time period 2,500 to 10,000 years following 2046, risks of radiological impacts are about one order of magnitude higher in the No Action Alternative and about half an order of magnitude higher in Alternative Group B than in the other alternative groups (see Volume II, Appendix I, Section I.3.4). These higher risks are the result of larger quantities of uranium reaching the river environment in the latter time period under the conditions inherent in these two alternative groups. Further, the risks of uranium chemical toxicological impacts to terrestrial and aquatic animal receptors are about two orders of magnitude higher for the No Action Alternative and about one order of magnitude higher for Alternative Group B than for the other alternative groups during the time period extending from 2,500 to 10,000 years after 2046 (see Volume II, Appendix I, Section I.3.5). These relative risks are described below in absolute terms.

Based on results presented in Volume II, Appendix I, Section I.3.5, the risk of radiological impacts to aquatic and terrestrial animals and plants from future contaminant releases would be very small. The risk of chronic uranium chemical toxicological impacts to terrestrial animal receptors also would be very small. The risk of chronic uranium chemical toxicological impacts to the carp (*Cyprinus carpio*), largescale/mountain sucker (*Catostomus macrocheilus/C. platyrhynchus*), and smallmouth bass (*Micropterus dolomieu*) would be negligible. The risk of uranium chemical toxicological impacts to all other aquatic animal species evaluated would be less than that of these three fish species, with the possible exception of the Woodhouse's toad (*Bufo woodhousii*) tadpole. The potential impact on this species is inconclusive because of the lack of species-specific uranium uptake and toxicity data and uncertainty regarding the applicability of available data (from fish studies) used to prepare risk calculations for this species in the HSW EIS (see Volume II, Appendix I, Section I.3.5). However, impacts to Woodhouse's toad populations are unlikely considering 1) the conservatism in the groundwater modeling that produced the uranium concentrations used in the risk assessment (see Volume II, Appendix G of this EIS) and 2) the assumption of simultaneous exposure to maximum uranium concentrations entering the river at different times from different disposal facilities. Uranium chemical toxicological impacts, if any, would not occur until approximately 10,000 years following 2046.

## 5.6 Socioeconomics

The primary socioeconomic region of interest is the Richland-Kennewick-Pasco metropolitan statistical area, comprising Benton and Franklin counties in Washington state (Tri-Cities region), where the vast majority of the socioeconomic impacts would be expected. Because the Tri-Cities region is the major retail and service center for the Hanford Site and its employees, over 90 percent of whom also live in Benton and Franklin counties, relatively little impact would be expected on the economies of the surrounding counties (Grant, Adams, Yakima, and Walla Walla counties in Washington or Umatilla County in Oregon) as a result of actions related to management of solid waste at Hanford.

The socioeconomic impacts are classified in terms of primary and secondary. Changes in Hanford employment and non-labor expenditures associated with the various alternative groups for dealing with LLW, MLLW, TRU waste, and ILAW are classified as primary impacts. Additional changes that result in the general regional economy and community as a result of these primary changes are classified as secondary effects. Examples of secondary impacts include changes in retail and service employment or changes in demand for housing. The total socioeconomic impact in the region is the sum of the primary and secondary impacts. Based on this analysis, the implementation of any of the HSW EIS alternative groups likely would have very small impacts on the local socioeconomic infrastructure, for instance housing, schools, medical support, and transportation.

Estimates of total employment impacts were calculated using a variant of the IMPLAN regional economic model (Minnesota IMPLAN Group, Inc. 1997) for the Tri-Cities region. These estimates were checked for consistency with the less-detailed estimates produced for the *Final Waste Management Programmatic Environmental Impact Statement for Managing Treatment, Storage, and Disposal of Radioactive and Hazardous Waste* (WM PEIS) (DOE 1997a) using the Regional Input-Output Modeling System (RIMS) of the U.S. Bureau of Economic Analysis. Allowing for differences in methods, the more-detailed estimates produced for the HSW EIS are in general agreement, but at the lower end of the range, with those produced by the earlier, less-detailed analysis in the WM PEIS. The HSW EIS estimate reports the changes in employment and earnings based on the most recently available historical data. The reports indicate that 93 percent of Hanford employees reside in the Tri-Cities region and that about 81 percent of all non-labor procurements made by Hanford management and operations contractors occur in the same region.

Impacts other than employment and income are largely based on changes in population, with respect to current capacities of the local roads, schools, waste and water treatment, and other elements of local infrastructure. Historical geographic patterns of settlement are assumed to persist.

For purposes of this analysis, a baseline forecast of budgets and employment at Hanford was constructed that reflect October 2001 budget plans and estimates at the U.S. Department of Energy (DOE), Richland Operations Office; DOE, Office of River Protection; and the Pacific Northwest National Laboratory for DOE and non-DOE work. The baseline was necessary to provide perspective on the size of changes in Hanford activity that may occur as a result of actions to manage Hanford solid waste. Table 5.19 shows the baseline scenario.

Because the time pattern of spending is different under each of the alternative groups, Figure 5.24 depicts the level of Hanford employment as a simple way of showing how the solid waste program scenarios compare both with each other and total Hanford activity over time. Because the Hanford Solid Waste Program is an ongoing function, even the No Action Alternative has changing levels of employment and spending associated with it. For purposes of the socioeconomic analysis, all impacts were calculated as changes from conditions in 2002. For example, Hanford Solid Waste Program employment rises from the 2002 level of roughly 435 to levels over 750, and then eventually declines below 200. The corresponding impacts on direct employment are roughly +350 workers and -200 workers, relative to current conditions. The analysis calculates the direct and indirect socioeconomic impacts of these changes in direct employment and associated programmatic spending at the Hanford Site. Figure 5.25 shows solid waste program employment in each case relative to the 2002 level. The time patterns of total spending are similar for Alternative Groups A through E, as shown in Figure 5.26. Alternative Groups C, D<sub>1</sub>, D<sub>2</sub>, D<sub>3</sub>, E<sub>1</sub>, E<sub>2</sub>, and E<sub>3</sub> all have virtually identical levels of spending and employment in each year, and all are similar to Alternative Group A. To simplify Figures 5.24 through 5.26, Alternative Groups C through E are represented by Alternative Group C.

Non-labor costs play a relatively larger role in the No Action Alternative (Lower Bound waste volume), so that total costs in that case peak in about 2005 at \$150 million and again in 2013 at about \$132 million (with corresponding employment peaks), decline until 2023, reach a plateau between 2023 and 2032, and then finally decline for good. All costs are just slightly lower in the No Action Alternative when the Hanford Only waste volume is considered. In analyzing the socioeconomic impacts of the alternative groups, emphasis was placed on finding years between 2002 and 2046 showing the largest impacts, either positive or negative. Because the time pattern of spending is different under each of the alternative groups, the largest impacts (positive or negative) sometimes occur in different years.

**Table 5.19.** Hanford Budget and Direct Employment Associated with Baseline Conditions

Variable	2002–2009	2010–2020	2021–2032	2033–2046
<b>Budget (in millions)</b> <sup>(a,b)</sup>	\$2,000–\$2,300	\$1,450–\$2,250	\$800–\$1,450	\$550–800
<b>Hanford Jobs</b> <sup>(b)</sup>	11,700–15,200	9,200–11,700	7,550–9,250	6,150–7,500
(a) Budget is in 2002 dollars.				
(b) Maximum and minimum during the period. Jobs rounded to nearest 50; budget to nearest 50 million. These values provide bounds for impacts.				

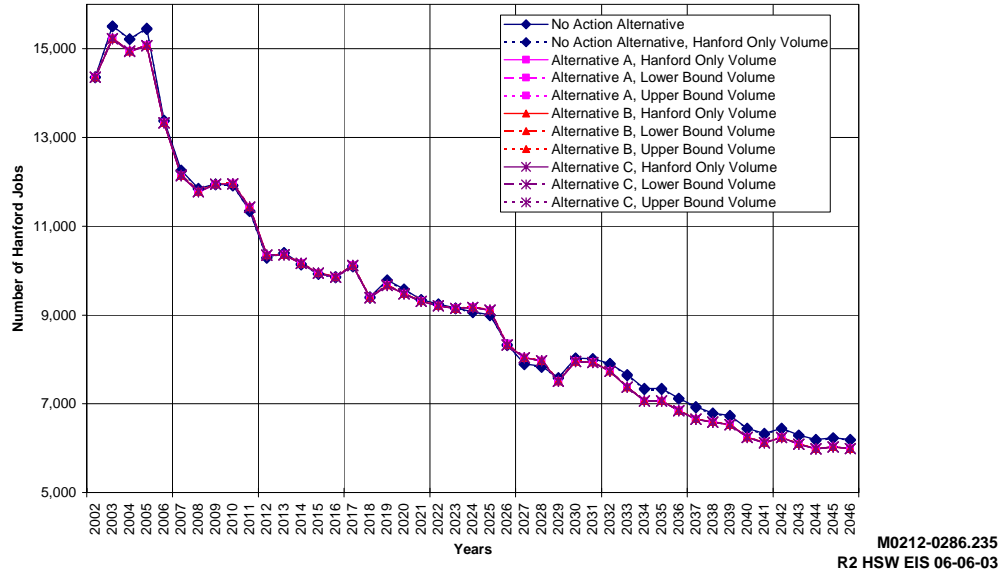


Figure 5.24. Impact of HSW EIS Alternative Groups on Total Hanford Employment

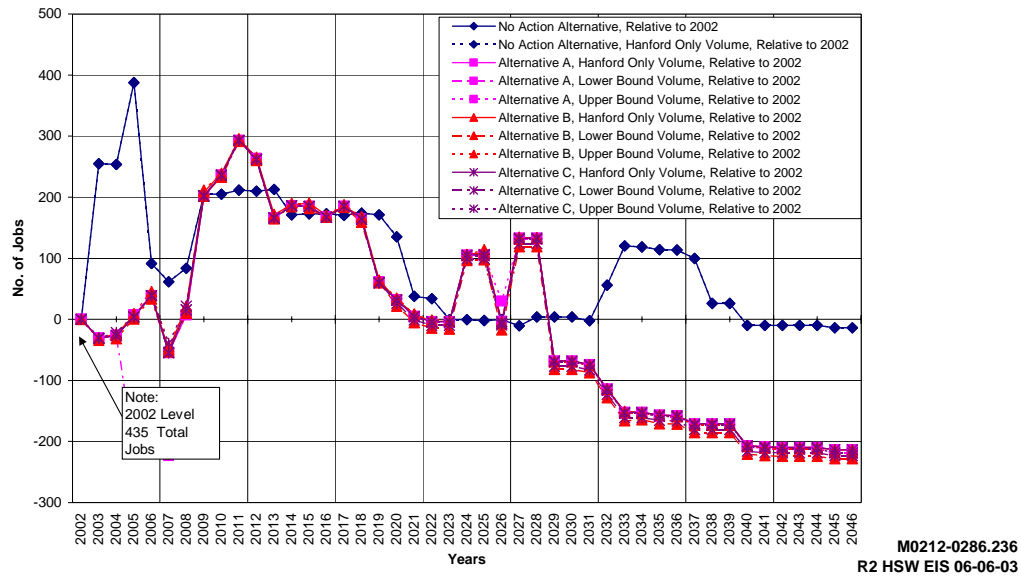
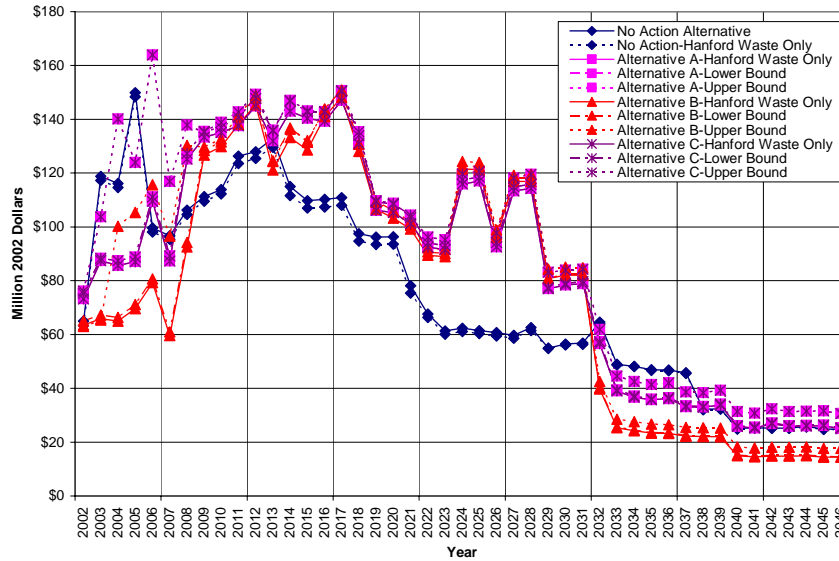


Figure 5.25. Impact of HSW EIS Alternative Groups on Solid Waste Program Employment





M0212-0286.237  
R2 HSW EIS 06-06-03

**Figure 5.26.** Impact of HSW EIS Alternative Groups on Solid Waste Program Total Costs

### 5.6.1 Alternative Group A

Table 5.20 shows the employment and population changes related to construction and operations of the additional required facilities relative to those expected under baseline conditions for certain key years.

For purposes of this analysis, the general level of employment and budget at the Hanford Site is assumed to follow the level discussed previously under the baseline conditions. Population impacts were calculated at 1.3 times total employment impacts, consistent with DOE (1996a). An unknown number of current Hanford workers could be reassigned to operations activities, reducing immigration to the region below the estimates shown in this section. Construction activity is assumed to require a normal proportion of new construction workers coming into the region.

Estimates of Hanford primary jobs and budget for LLW, MLLW, and TRU waste operations are provided in the Technical Information Document (FH 2004) for Alternative Group A. Primary jobs and budget for ILAW operations were calculated in support of the ILAW EIS, which now has been merged with this document. For construction activity, FH (2004) and the ILAW documentation report the construction year or years, total labor-years required, and schedule. This procedure resulted in an estimate of the number of jobs by year, consistent with the peak year and total labor-years required.

**Table 5.20.** Socioeconomic Impacts Associated with Alternative Group A, Relative to Baseline Conditions<sup>(a)</sup>

<b>Alternative Group A</b>	<b>2011</b>	<b>2017</b>	<b>2032</b>	<b>2046</b>
<b>Hanford Solid Waste Program Total Budget (Million 2002\$)</b>				
Hanford Only Volume	\$138	\$147	\$57	\$25
Lower Bound Volume	\$141	\$150	\$57	\$25
Upper Bound Volume	\$143	\$151	\$62	\$31
<b>Hanford Jobs<sup>(b)</sup></b>				
Solid Waste Program Total, Hanford Only Volume	750	650	350	250
Solid Waste Program Total, Lower Bound Volume	800	650	350	250
Solid Waste Program Total, Upper Bound Volume	750	650	350	250
<i>Impact, Hanford Only Volume</i>	<i>300</i>	<i>200</i>	<i>(100)</i>	<i>(200)</i>
<i>Impact, Lower Bound Volume</i>	<i>300</i>	<i>200</i>	<i>(100)</i>	<i>(200)</i>
<i>Impact, Upper Bound Volume</i>	<i>300</i>	<i>200</i>	<i>(100)</i>	<i>(200)</i>
<b>Non-Labor Procurements (Million 2002\$)<sup>(b)</sup></b>				
Solid Waste Program Total, Hanford Only Volume	\$83	\$100	\$30	\$6
Solid Waste Program Total, Lower Bound Volume	\$85	\$102	\$31	\$6
Solid Waste Program Total, Upper Bound Volume	\$88	\$103	\$35	\$11
<i>Impact, Hanford Only Volume</i>	<i>\$45</i>	<i>\$61</i>	<i>(\$8)</i>	<i>(\$33)</i>
<i>Impact, Lower Bound Volume</i>	<i>\$46</i>	<i>\$63</i>	<i>(\$9)</i>	<i>(\$34)</i>
<i>Impact, Upper Bound Volume</i>	<i>\$47</i>	<i>\$62</i>	<i>(\$6)</i>	<i>(\$29)</i>
<b>Tri-Cities Region Jobs Impacts<sup>(c)</sup></b>				
<i>Hanford Only Volume</i>	<i>1,400</i>	<i>1,450</i>	<i>(350)</i>	<i>(1,000)</i>
<i>Lower Bound Volume</i>	<i>1,400</i>	<i>1,500</i>	<i>(400)</i>	<i>(1,050)</i>
<i>Upper Bound Volume</i>	<i>1,450</i>	<i>1,500</i>	<i>(350)</i>	<i>(1,000)</i>
<b>Population Change Impacts<sup>(c)</sup></b>				
<i>Hanford Only Volume</i>	<i>1,800</i>	<i>1,900</i>	<i>(500)</i>	<i>(1,350)</i>
<i>Lower Bound Volume</i>	<i>1,800</i>	<i>1,950</i>	<i>(500)</i>	<i>(1,400)</i>
<i>Upper Bound Volume</i>	<i>1,850</i>	<i>1,900</i>	<i>(450)</i>	<i>(1,250)</i>
<p>(a) Numbers in parentheses denote lower level of activity (negative impact) relative to baseline conditions. Area jobs and population rounded to nearest 50.</p> <p>(b) Hanford Solid Waste Program totals and positive or negative impact or change (italicized text) relative to 2002. These impacts provide the basis for area-wide impacts.</p> <p>(c) Maximum positive or negative impact only.</p>				

The solid waste program budget under Alternative Group A is projected to peak in 2017, with employment slightly higher in 2011. In 2011, solid waste program employment is expected to be about 750 to 800 for the Hanford Only, Lower Bound, and Upper Bound waste volumes, representing an increment of about 300 to 350 to the baseline. Additionally, there is an increment to non-labor procurements of \$83 to \$88 million relative to the baseline (see Table 5.20). The largest total impact on community employment (Hanford and non-Hanford workers) in the Tri-Cities region would be about +1,450 to +1,500 relative to the baseline in 2017. In Alternative Group A, the level of solid waste program employment and spending is above that in the No Action Alternative for the period 2007 through 2032. Employment falls below 2002 levels beginning about the year 2029, and spending does the same in 2032, reflecting an incremental reduction in the DOE mortgage (that is, ongoing annual costs of managing and safekeeping facilities and wastes from former activities) at the Hanford Site. As a result, a slight negative impact would occur on the economy after about 2032.

The population impact is expected to peak in 2017, with an increase in population of 1,900 to 1,950, representing an increase of about 1 percent over the 2000 Census population of 191,822 (Census 2000a, 2000b). Because most communities can usually handle an increase in population of up to 5 percent without disruption in services (Gilmore and Duff 1975), the effects on demand for community infrastructure and services would be small due to the impact of the solid waste program alone. The impact of the long-term reduction in population of 1,250 to 1,400 shown in Table 5.20 is about 0.7 percent of the 2000 baseline. The infrastructure impacts likely would be very small.

## **5.6.2 Alternative Group B**

Estimates of Hanford primary jobs and budget for LLW, MLLW, and TRU waste operations and construction are provided in the Technical Information Document (FH 2004) for Alternative Group B. Primary jobs and budget for ILAW operations were calculated in support of the ILAW EIS, which now has been merged with this document.

Table 5.21 shows the employment and population changes related to construction and operations of the additional required facilities relative to those expected under baseline conditions for certain key years. The scenarios in Alternative Group B achieve their peak positive impact on economic activity in 2017, with the peak total Tri-Cities employment impact reaching about 1,650 above baseline conditions for the Hanford Only waste volume and 1,750 for the Upper Bound waste volume. The peak total of Tri-Cities employment increases represents a 2 percent increase over the 1999 baseline of 88,100 (DOE-RL 2000a), the last year for which complete data are available. After 2030, the largest negative impact on employment is the loss of 950 to 1,100 jobs relative to the baseline in the year 2046.

Corresponding population increases and decreases range from +2,150 to 2,250 in 2017 to -1,250 to -1,400 in 2046, representing an increase of about 1.2 percent relative to the 2000 Census population of 191,822 (Census 2000a, 2000b) and a decrease of 0.7 percent relative to the 2000 Census value. By themselves, these figures imply that the incremental impact on demand for community infrastructure and services likely would be very small.

**Table 5.21.** Socioeconomic Impacts Associated with Alternative Group B, Relative to Baseline Conditions<sup>(a)</sup>

<b>Alternative Group B</b>	<b>2011</b>	<b>2017</b>	<b>2032</b>	<b>2046</b>
<b>Hanford Solid Waste Program Total Budget (Million 2002\$)</b>				
Hanford Only Volume	\$138	\$148	\$40	\$14
Lower Bound Volume	\$141	\$151	\$40	\$15
Upper Bound Volume	\$141	\$151	\$40	\$18
<b>Hanford Jobs<sup>(b)</sup></b>				
Solid Waste Program Total, Hanford Only Volume	800	700	350	250
Solid Waste Program Total, Lower Bound Volume	800	700	350	250
Solid Waste Program Total, Upper Bound Volume	800	700	350	250
<i>Impact, Hanford Only Volume</i>	<i>300</i>	<i>200</i>	<i>(100)</i>	<i>(200)</i>
<i>Impact, Lower Bound Volume</i>	<i>300</i>	<i>200</i>	<i>(150)</i>	<i>(250)</i>
<i>Impact, Upper Bound Volume</i>	<i>300</i>	<i>200</i>	<i>(100)</i>	<i>(200)</i>
<b>Non-Labor Procurements (Million 2002\$)<sup>(b)</sup></b>				
Solid Waste Program Total, Hanford Only Volume	\$83	\$100	\$13	\$5
Solid Waste Program Total, Lower Bound Volume	\$85	\$102	\$13	\$5
Solid Waste Program Total, Upper Bound Volume	\$86	\$102	\$15	\$2
<i>Impact, Hanford Only Volume</i>	<i>\$55</i>	<i>\$72</i>	<i>(\$15)</i>	<i>(\$33)</i>
<i>Impact, Lower Bound Volume</i>	<i>\$56</i>	<i>\$73</i>	<i>(\$16)</i>	<i>(\$34)</i>
<i>Impact, Upper Bound Volume</i>	<i>\$58</i>	<i>\$75</i>	<i>(\$12)</i>	<i>(\$29)</i>
<b>Tri-Cities Region Jobs Impacts<sup>(c)</sup></b>				
<i>Hanford Only Volume</i>	<i>1,550</i>	<i>1,650</i>	<i>(500)</i>	<i>(1,000)</i>
<i>Lower Bound Volume</i>	<i>1,600</i>	<i>1,700</i>	<i>(550)</i>	<i>(1,100)</i>
<i>Upper Bound Volume</i>	<i>1,650</i>	<i>1,700</i>	<i>(450)</i>	<i>(950)</i>
<b>Population Change Impacts<sup>(c)</sup></b>				
<i>Hanford Only Volume</i>	<i>2,050</i>	<i>2,150</i>	<i>(650)</i>	<i>(1,350)</i>
<i>Lower Bound Volume</i>	<i>2,050</i>	<i>2,200</i>	<i>(700)</i>	<i>(1,400)</i>
<i>Upper Bound Volume</i>	<i>2,100</i>	<i>2,250</i>	<i>(600)</i>	<i>(1,250)</i>
<p>(a) Numbers in parentheses denote lower level of activity (negative impact) relative to baseline conditions. Area jobs and population rounded to nearest 50.</p> <p>(b) Hanford Solid Waste Program totals and positive or negative impact or change (italicized text) relative to 2002. These impacts provide the basis for area-wide impacts.</p> <p>(c) Maximum positive or negative impact only.</p>				

### 5.6.3 Alternative Group C

Estimates of Hanford primary jobs and budget for LLW, MLLW, and TRU waste operations and construction are derived from the Technical Information Document (FH 2004) for Alternative Group C. Primary jobs and budget for ILAW operations were calculated in support of the ILAW EIS, which now has been merged with this document.

Table 5.22 shows the employment and population changes related to construction and operations of the additional required facilities relative to those expected under baseline conditions for certain key years. The scenarios in Alternative Group C achieve their peak positive impact on economic activity in 2017, where projected employment increases of 1,450 to 1,500 represent a 1.7 percent increase over the 1999 baseline of 88,100 (DOE-RL 2000a), the last year for which complete data are available. After 2030, the largest negative impact on employment is the loss of 950 to 1,050 jobs relative to the baseline in the year 2046.

Corresponding population increases and decreases range from +1,900 to +1,950 in 2017 to -1,250 to -1,400 in 2046, representing an increase of about 1 percent relative to the 2000 Census population of 191,822 (Census 2000a, 2000b) and a decrease of 0.7 percent relative to the 2000 Census value. By themselves, these figures imply that an incremental impact on demand for community infrastructure and services likely would be very small.

### 5.6.4 Alternative Group D

Estimates of Hanford primary jobs and budget for LLW, MLLW, and TRU waste operations and construction are derived from the Technical Information Document (FH 2004) for Alternative Group D. Primary jobs and budget for ILAW operations were calculated in support of the ILAW EIS, which now has been merged with this document. It is assumed there is no difference in cost and employment among Alternative Groups D<sub>1</sub>, D<sub>2</sub>, and D<sub>3</sub>, as similar activities are conducted in different onsite locations that have similar characteristics.

Table 5.23 shows the employment and population changes related to construction and operations of the additional required facilities relative to those expected under baseline conditions for certain key years. The scenarios in Alternative Group D achieve their peak positive impact on economic activity in 2017, with the peak total Tri-Cities employment impact reaching about 1,450. The peak total of Tri-Cities employment increases represents a 1.6-percent increase over the 1999 baseline of 88,100 (DOE-RL 2000a), the last year for which complete data are available. After 2030, the largest negative impact on employment is the loss of 950 to 1,050 jobs relative to the baseline in the year 2046.

Corresponding population increases and decreases range from +1,900 in 2017 to -1,250 to -1,350 in 2046, representing a net increase of about 1 percent relative to the 2000 Census population of 191,822 (Census 2000a, 2000b) and a decrease of 0.7 percent relative to the 2000 Census value. By themselves, these figures imply that incremental impact on demand for community infrastructure and services likely would be very small.

**Table 5.22.** Socioeconomic Impacts Associated with Alternative Group C, Relative to Baseline Conditions<sup>(a)</sup>

<b>Alternative Group C</b>	<b>2011</b>	<b>2017</b>	<b>2032</b>	<b>2046</b>
<b>Hanford Solid Waste Program Total Budget (Million 2002\$)</b>				
Hanford Only Volume	\$138	\$147	\$57	\$25
Lower Bound Volume	\$141	\$150	\$57	\$25
Upper Bound Volume	\$143	\$151	\$62	\$31
<b>Hanford Jobs<sup>(b)</sup></b>				
Solid Waste Program Total, Hanford Only Volume	750	650	350	250
Solid Waste Program Total, Lower Bound Volume	800	650	350	250
Solid Waste Program Total, Upper Bound Volume	750	650	350	250
<i>Impact, Hanford Only Volume</i>	<i>300</i>	<i>200</i>	<i>(100)</i>	<i>(200)</i>
<i>Impact, Lower Bound Volume</i>	<i>300</i>	<i>200</i>	<i>(100)</i>	<i>(200)</i>
<i>Impact, Upper Bound Volume</i>	<i>300</i>	<i>200</i>	<i>(100)</i>	<i>(200)</i>
<b>Non-Labor Procurements (Million 2002\$)<sup>(b)</sup></b>				
Solid Waste Program Total, Hanford Only Volume	\$83	\$100	\$30	\$6
Solid Waste Program Total, Lower Bound Volume	\$85	\$102	\$31	\$6
Solid Waste Program Total, Upper Bound Volume	\$88	\$103	\$35	\$11
<i>Impact, Hanford Only Volume</i>	<i>\$45</i>	<i>\$61</i>	<i>(\$8)</i>	<i>(\$33)</i>
<i>Impact, Lower Bound Volume</i>	<i>\$46</i>	<i>\$63</i>	<i>(\$9)</i>	<i>(\$34)</i>
<i>Impact, Upper Bound Volume</i>	<i>\$47</i>	<i>\$62</i>	<i>(\$6)</i>	<i>(\$29)</i>
<b>Tri-Cities Region Jobs Impacts<sup>(c)</sup></b>				
<i>Hanford Only Volume</i>	<i>1,400</i>	<i>1,450</i>	<i>(350)</i>	<i>(1,000)</i>
<i>Lower Bound Volume</i>	<i>1,400</i>	<i>1,500</i>	<i>(400)</i>	<i>(1,050)</i>
<i>Upper Bound Volume</i>	<i>1,400</i>	<i>1,450</i>	<i>(350)</i>	<i>(950)</i>
<b>Population Change Impacts<sup>(c)</sup></b>				
<i>Hanford Only Volume</i>	<i>1,800</i>	<i>1,900</i>	<i>(500)</i>	<i>(1,350)</i>
<i>Lower Bound Volume</i>	<i>1,800</i>	<i>1,950</i>	<i>(550)</i>	<i>(1,400)</i>
<i>Upper Bound Volume</i>	<i>1,850</i>	<i>1,900</i>	<i>(450)</i>	<i>(1,250)</i>
<p>(a) Numbers in parentheses denote lower level of activity (negative impact) relative to baseline conditions. Area jobs and population rounded to nearest 50.</p> <p>(b) Hanford Solid Waste Program totals and positive or negative impact or change (italicized text) relative to 2002. These impacts provide the basis for area-wide impacts.</p> <p>(c) Maximum positive or negative impact only.</p>				

**Table 5.23.** Socioeconomic Impacts Associated with Alternative Group D, Relative to Baseline Conditions<sup>(a)</sup>

<b>Alternative Group D</b>	<b>2011</b>	<b>2017</b>	<b>2032</b>	<b>2046</b>
<b>Hanford Solid Waste Program Total Budget (Million 2002\$)</b>				
Hanford Only Volume	\$138	\$147	\$56	\$25
Lower Bound Volume	\$140	\$150	\$59	\$27
Upper Bound Volume	\$143	\$151	\$64	\$33
<b>Hanford Jobs<sup>(b)</sup></b>				
Solid Waste Program Total, Hanford Only Volume	750	650	350	250
Solid Waste Program Total, Lower Bound Volume	800	650	350	250
Solid Waste Program Total, Upper Bound Volume	800	650	350	250
<i>Impact, Hanford Only Volume</i>	<i>300</i>	<i>200</i>	<i>(100)</i>	<i>(200)</i>
<i>Impact, Lower Bound Volume</i>	<i>300</i>	<i>200</i>	<i>(100)</i>	<i>(200)</i>
<i>Impact, Upper Bound Volume</i>	<i>300</i>	<i>200</i>	<i>(100)</i>	<i>(200)</i>
<b>Non-Labor Procurements (Million 2002\$)<sup>(b)</sup></b>				
Solid Waste Program Total, Hanford Only Volume	\$83	\$91	\$30	\$6
Solid Waste Program Total, Lower Bound Volume	\$85	\$102	\$32	\$8
Solid Waste Program Total, Upper Bound Volume	\$89	\$104	\$37	\$13
<i>Impact, Hanford Only Volume</i>	<i>\$45</i>	<i>\$61</i>	<i>(\$8)</i>	<i>(\$33)</i>
<i>Impact, Lower Bound Volume</i>	<i>\$45</i>	<i>\$62</i>	<i>(\$8)</i>	<i>(\$33)</i>
<i>Impact, Upper Bound Volume</i>	<i>\$46</i>	<i>\$61</i>	<i>(\$6)</i>	<i>(\$30)</i>
<b>Tri-Cities Region Jobs Impacts<sup>(c)</sup></b>				
<i>Hanford Only Volume</i>	<i>1,400</i>	<i>1,450</i>	<i>(350)</i>	<i>(1,000)</i>
<i>Lower Bound Volume</i>	<i>1,400</i>	<i>1,450</i>	<i>(350)</i>	<i>(1,050)</i>
<i>Upper Bound Volume</i>	<i>1,400</i>	<i>1,450</i>	<i>(350)</i>	<i>(950)</i>
<b>Population Change Impacts<sup>(c)</sup></b>				
<i>Hanford Only Volume</i>	<i>1,800</i>	<i>1,900</i>	<i>(500)</i>	<i>(1,350)</i>
<i>Lower Bound Volume</i>	<i>1,800</i>	<i>1,900</i>	<i>(500)</i>	<i>(1,350)</i>
<i>Upper Bound Volume</i>	<i>1,850</i>	<i>1,900</i>	<i>(450)</i>	<i>(1,250)</i>
<p>(a) Numbers in parentheses denote lower level of activity (negative impact) relative to baseline conditions. Area jobs and population rounded to nearest 50.</p> <p>(b) Hanford Solid Waste Program totals and positive or negative impact or change (italicized text) relative to 2002. These impacts provide the basis for area-wide impacts.</p> <p>(c) Maximum positive or negative impact only.</p>				

### 5.6.5 Alternative Group E

Estimates of Hanford primary jobs and budget for LLW, MLLW, and TRU waste operations and construction are derived from the Technical Information Document (FH 2004) for Alternative Group E. Primary jobs and budget for ILAW operations were calculated in support of the ILAW EIS, which now has been merged with this document. Primary jobs and budget for Alternative Group E ILAW operations are assumed to be the same as in Alternative Group D. It is assumed there is no difference in cost and employment among Alternative Groups E<sub>1</sub>, E<sub>2</sub>, and E<sub>3</sub>, as similar activities are conducted in different onsite locations that have similar characteristics.

Impacts on employment and population are the same as those for Alternative Group D (see Section 5.6.4)

### 5.6.6 No Action Alternative

Estimates of Hanford primary jobs and budget for LLW, MLLW, and TRU waste construction and operations are provided in the Technical Information Document (FH 2004) for the No Action Alternative, Lower Bound volume. Costs and budget for the No Action Alternative with the Hanford Only waste volume are nearly the same as for the Lower Bound volume and are derived by scaling for the slightly lower volume of wastes handled in the Hanford Only waste volume case. Primary jobs and budget for ILAW operations were calculated in support of the ILAW EIS, which now has been merged with this document.

Total employment at Hanford is currently expected to increase by as much as 3,000 jobs (from the 2001 level of 12,000, the last year of historical data) through 2005, as the Hanford Waste Treatment Plant is constructed and begins operations (see Figure 5.22). Overall, the activity associated with the No Action Alternative would add increases in annual budgets of as much as \$150 million in 2005 (an increase of \$82 million from the level in 2002) and up to 400 additional jobs onsite to this baseline. After 2040, employment in solid waste management operations would fall to about the baseline value, as shown in Figure 5.23, while the solid waste management budget would decline below the 2002 level by 2032 (see Figure 5.24). Overall, the Tri-Cities socioeconomic conditions would continue as they currently are, with employment increasing and fluctuating in the short run and generally declining over the long-term.

Table 5.24 shows the current solid waste program budget, employment, and estimated non-labor procurements that would continue under the No Action Alternative.

In 2002, the solid waste management program (including ILAW) required a total budget of about \$68 million and employed slightly over 400 workers. As shown in Figure 5.23, in 2005 (the highest direct employment year), about 400 additional employees beyond 2002 levels would be needed to operate and support the solid waste program (over 800 total). This is also the year with the largest impact on total community employment (Hanford and non-Hanford workers), with about 1,800 workers needed beyond baseline levels (see Table 5.24). This impact relative to 2002 is noticeable but not large (about 2 percent



of the 1999 base of 88,100 total non-farm jobs) (DOE-RL 2000a). Area population might increase above baseline by as many as 2,350 people, or about 1.3 percent of the 2000 Census population of 191,822 (Census 2000a, 2000b).

**Table 5.24.** Socioeconomic Impacts Associated with the No Action Alternative, Relative to Baseline Conditions<sup>(a)</sup>

No Action Alternatives	2005	2013	2032	2046
<b>Hanford Solid Waste Program Total Budget (Million 2002\$)</b>				
Hanford Only Volume	\$148	\$130	\$64	\$25
Lower Bound Volume	\$150	\$133	\$65	\$25
<b>Hanford Jobs<sup>(b)</sup></b>				
Solid Waste Program Total, Hanford Only Volume	850	700	500	450
Solid Waste Program Total, Lower Bound Volume	850	700	550	450
<i>Impact, Hanford Only Volume</i>	<i>400</i>	<i>200</i>	<i>50</i>	<i>(0)</i>
<i>Impact, Lower Bound Volume</i>	<i>400</i>	<i>200</i>	<i>50</i>	<i>(0)</i>
<b>Non-Labor Procurements (Million 2002\$)<sup>(b)</sup></b>				
Solid Waste Program Total, Hanford Only Volume	\$86	\$80	\$26	0
Solid Waste Program Total, Lower Bound Volume	\$86	\$82	\$25	0
<i>Impact, Hanford Only Volume</i>	<i>\$54</i>	<i>\$47</i>	<i>(\$10)</i>	<i>(\$38)</i>
<i>Impact, Lower Bound Volume</i>	<i>\$54</i>	<i>\$48</i>	<i>(\$10)</i>	<i>(\$39)</i>
<b>Tri-Cities Region Jobs Impact<sup>(c)</sup></b>				
<i>Impact, Hanford Only Volume</i>	<i>1,800</i>	<i>1,350</i>	<i>50</i>	<i>(700)</i>
<i>Impact, Lower Bound Volume</i>	<i>1,800</i>	<i>1,400</i>	<i>50</i>	<i>(700)</i>
<b>Population Change Impacts<sup>(c)</sup></b>				
<i>Impact, Hanford Only Volume</i>	<i>2,350</i>	<i>1,750</i>	<i>50</i>	<i>(900)</i>
<i>Impact, Lower Bound Volume</i>	<i>2,350</i>	<i>1,800</i>	<i>50</i>	<i>(950)</i>
<p>(a) Numbers in parentheses denote lower level of activity (negative impact) relative to baseline conditions. Area jobs and population rounded to nearest 50.</p> <p>(b) Hanford Solid Waste Program totals and positive or negative impact or change (italicized text) relative to 2002. These impacts provide the basis for area-wide impacts.</p> <p>(c) Maximum positive or negative impact only.</p>				

## 5.7 Cultural Resources Impacts

This section describes the potential impact of implementing the alternative groups as previously stated in this HSW EIS on Hanford Site cultural resources, namely archaeological sites, archaeological features, artifacts, and historic buildings. In addition, several places in the vicinity of the 200 Areas have had, and continue to have, traditional roles in Native American creation beliefs and the cultural heritage of the Wanapum, the Confederated Tribes of the Umatilla Indian Reservation, the Nez Perce Tribe, and the Yakama Nation. These places include, but are not limited to, the Columbia River, Gable Mountain, Gable Butte, and Rattlesnake Mountain.

Archaeological surveys of all undeveloped portions of the 200 East Area and a random sample of 50 percent of undeveloped portions of the 200 West Area indicate no findings of archaeological sites. However, some small sites exist within the boundaries of the 200 East and 200 West Areas (Chatters and Cadoret 1990).

A prominent archaeological resource located in the 200 Areas is an extensive linear feature known as the White Bluffs Road, a portion of which passes diagonally southwest to northeast through the 200 West Area. The road in its entirety was determined eligible for listing in the National Register of Historic Places (National Register). Segments of the White Bluffs Road that are located in the 200 West Area, however, have been determined to be non-contributing. Such non-contributing segments of the White Bluffs Road are those that do not add to the historic significance of the road, but retain evidence of its contiguous bearing.

Originally used as a Native American trail, the White Bluffs Road played a role in Euro-American immigration, development, agricultural, and Hanford Site operations. The White Bluffs Road survey of 2000 recorded an additional 54 historic isolated artifacts and 2 prehistoric isolated finds, as well as 6 cans. In addition, 58 buildings and structures in the 200 East and 200 West Areas have been determined eligible for the National Register as contributing properties within the Historic District recommended for individual documentation (Neitzel 2001). Mitigation has been completed for these buildings and structures.

Previous archaeological investigations and historical research indicate that Native Americans used sites throughout the Cold Creek Valley, primarily near water sources, for campgrounds, ceremonial uses, plant gathering, hunting, and possibly the grazing of cattle and horses from the prehistoric period to 1943. Ethno-historic research suggests that Native American use of Area C was limited to travel through the vicinity to destinations along the Columbia and Yakima rivers. There is a possibility that Native American use of the area prior to Euro-American contact, even extending as far back as 10,000 years, occurred. If so, the archaeological remains associated with that area and time period likely have been buried by sand dune activity and wind blown deposition.

Both Native Americans and Euro-Americans used trails and roads, such as the White Bluffs Road, to the west and north of Area C. Research also indicates a well-used trail connected the Benson Ranch (on the western boundary of Area C) to Rattlesnake Springs. Historic maps show the Ellensburg to Yakima River Road passed through Rattlesnake Springs and traversed the central and southern sections of Area C

as early as 1881. A four-wheel drive dirt road in the northern section of Area C, parallel to Dry Creek, connected Cold Creek Valley with the city of Richland prior to the construction of State Route 240 through the Hanford Site. Historic occupations in the Cold Creek Valley seem to have been centered on sheep and cattle grazing and the raising of horses. Farmsteads have been identified west of Area C where irrigation water from Rattlesnake Springs allowed for the cultivation of alfalfa and grain.

For activities associated with this HSW EIS, cultural resources surveys have been conducted of Area C (borrow pit site); the T Plant Complex; the CWC and 218-W-5 LLBG expansion areas; the proposed ILAW disposal facility in the 200 East Area near the PUREX Plant; the melter trench in the 200 East and 200 West Areas; groundwater well installations in the 200 West Area; and lined modular facility locations in the 200 Area East, near the PUREX Plant, and at ERDF. Details are provided in Volume II, Appendix K, as are copies of consultation letters with the State of Washington Office of Archaeology and Historic Preservation.

Installation and operation of mobile accelerated process lines would be within the CWC buildings or near the TRU waste trenches and, based on surveys of those areas, there would appear to be no potential for impacts on cultural resources.

Because Area C is within the viewshed from Rattlesnake Mountain, the project might have an indirect effect on the characteristics that contribute to the cultural and religious significance of Rattlesnake Mountain to local tribes. Additional information on aesthetic and scenic impacts of these activities is presented in Section 5.12.

Section 5.18 provides information regarding the protection of cultural resources discovered during construction or operations.

### **5.7.1 Alternative Group A**

The principal potential for impacts on cultural resources in Alternative Group A (Hanford Only, Lower Bound, and Upper Bound waste volumes) is associated with obtaining materials for the Modified RCRA Subtitle C Barrier to be placed over the disposal sites. This material, which includes basalt, sand, gravel, and silt/loam, would be obtained from a borrow pit in Area C, the location of which is shown in Volume II, Appendix D, Figure D.9. The borrow pit is within an area of about 926 ha (2287 ac), of which about 73 ha (180 ac) would be the maximum area excavated.

There is a reasonable likelihood that archaeological sites are located within Area C. However, any sites are likely to be buried, as the field reconnaissance failed to locate any on the surface. Little is known about the pre-contact use of the Cold Creek Valley; thus, any sites located there would provide an opportunity to gain new knowledge about prehistoric life. Further, if campsites or village sites were found, human remains and possibly cemeteries might also be located there.

Prior to construction activities associated with waste management operations, additional research as well as a 100-percent pedestrian archaeological survey would be needed to identify and address potential cultural impacts. Given the possibility for buried deposits, some methodology would likely be needed to

observe the subsurface. Depending upon conditions or circumstances, ground-penetrating radar, shovel testing, or backhoe testing might be appropriate, as would monitoring for cultural resources during construction. Frequency of monitoring may range from continuous to intermittent to periodic.

Modifications to the T Plant Complex are not expected to impact significant cultural resources. Any effects to T Plant have been mitigated through Historic American Engineering Record documentation and through historical narratives and individual building documentation compiled in *History of Plutonium Production Facilities at the Hanford Site Historic District, 1943-1990* (DOE-RL 2002a).

Cultural resources surveys of the proposed locations of the ILAW disposal facility, melter trench, and groundwater well installations in the 200 East and West Areas were conducted. The surveys concluded that the proposed locations in Alternative Group A would have no effect on historic properties in the 200 East and West Areas.

### **5.7.2 Alternative Group B**

In Alternative Group B, the potential for impacts on cultural resources at the Area C borrow pit would be slightly greater than those for Alternative Group A, based on the area being disturbed in order to obtain the materials required for the Modified RCRA Subtitle C Barrier for the LLBGs.

In this alternative group, a new waste processing facility would be located directly west of WRAP in the 200 West Area. Previous cultural resources surveys conducted in the CWC expansion area concluded that no known historic properties or archaeological resources are located within the footprint of the new facility.

As in Alternative Group A, cultural resources surveys of the proposed locations of the ILAW disposal facility (and multiple lined trenches in the 200 West Area), melter trench, and groundwater well installations were conducted. The surveys concluded that the proposed locations in Alternative Group B would have no effect on historic properties in the 200 East and West Areas.

### **5.7.3 Alternative Group C**

In Alternative Group C, the potential for impacts on cultural resources at the Area C borrow pit would be slightly less than those for Alternative Groups A and B, based on the area being disturbed in order to obtain the materials required for the Modified RCRA Subtitle C Barrier for the LLBGs.

In this alternative group, LLW would be located in the 200 West Area, MLLW would be located in the 200 East Area, and ILAW and the melter trench would be located near the PUREX Plant. Previous cultural resources surveys conducted in the CWC expansion area concluded that no known historic properties or archaeological resources are located within these areas.

As in Alternative Groups A and B, cultural resources surveys of the proposed locations of the ILAW disposal facility (and multiple lined trenches in the 200 West Area), melter trench, and groundwater well

installations were conducted. The surveys concluded that the proposed locations in Alternative Group C would have no effect on historic properties in the 200 East and West Areas.

#### **5.7.4 Alternative Group D**

This alternative group contains three subalternative groupings that depend on the location of disposal in a lined modular facility. D<sub>1</sub> would locate the disposal facility near the PUREX Plant, D<sub>2</sub> would locate the disposal facility in the 200 East LLBGs, and D<sub>3</sub> would locate the disposal facility at ERDF between the 200 East and 200 West areas.

In Alternative Group D, the potential for impacts on cultural resources at the Area C borrow pit would be slightly less than those for Alternative Groups A, B, and C, based on the area being disturbed in order to obtain the materials required for the Modified RCRA Subtitle C Barrier for the LLBGs.

As in Alternative Groups A, B, and C, cultural resources surveys of the proposed locations of the ILAW disposal facility (and multiple lined trenches in the 200 West Area), melter trench, and ground-water well installations were conducted. The surveys concluded that the proposed locations in this alternative group would have no effect on historic properties in the 200 East and West Areas, as well as at ERDF, as called out in Alternative Group D<sub>3</sub>.

#### **5.7.5 Alternative Group E**

This alternative group contains three subalternative groupings that depend on the location of disposal in lined modular facilities. E<sub>1</sub> would locate the LLW and MLLW disposal facilities in the 200 East LLBGs and the melters and ILAW at ERDF, E<sub>2</sub> would locate the LLW and MLLW disposal facilities near the PUREX Plant and the melters and ILAW at ERDF, and E<sub>3</sub> would locate the LLW and MLLW disposal facilities at ERDF and the melters and ILAW near the PUREX Plant.

In Alternative Group E, the potential for impacts on cultural resources at the Area C borrow pit would be the same as those for Alternative Group D and slightly less than the potential for impacts for Alternative Groups A, B, and C, based on the area being disturbed in order to obtain the materials required for the Modified RCRA Subtitle C Barrier for the LLBGs.

As in Alternative Groups A, B, C, and D, cultural resources surveys of the proposed locations of the ILAW disposal facility (and multiple lined trenches in the 200 West Area), melter trench, and ground-water well installations were conducted. The surveys concluded that the proposed locations in this alternative would have no effect to historic properties in the 200 East and West Areas, as well as at ERDF, as called out for in Alternative Group D<sub>3</sub>, and the other subalternatives in this grouping.

#### **5.7.6 No Action Alternative**

The No Action Alternative consists essentially of the continuation of current solid waste management practices.

In the No Action Alternative, materials would only be needed for a Modified RCRA Subtitle C Barrier over the two existing MLLW trenches in the 200 West Area and the Hanford Barrier over ILAW near the PUREX Plant at closure. Thus the amount of material required from the borrow pit would be substantially smaller than that for action alternative groups. Regardless, the same approach would be necessary to protect presently undisclosed cultural resources in the Area C borrow pit.

In addition, the CWC would be expanded to store MLLW and TRU waste that could not be treated or disposed of elsewhere. About 36 ha (89 ac) directly south of the existing CWC buildings would be needed, as would about 30 ha (74 ac) in the 218-W-5 Expansion Area just to the west of the CWC. Staff of the Hanford Cultural Resources Laboratory conducted a records and literature search that revealed the CWC expansion area has been previously surveyed for cultural resources. The cultural resources surveys concluded that no known historic properties or archaeological resources are located within the CWC expansion area.

## 5.8 Traffic and Transportation

Presented in this section are the results of an evaluation of the impacts of onsite shipments of LLW, MLLW (including melters), TRU wastes (including mixed TRU wastes), and ILAW to treatment and disposal facilities; shipments of LLW, MLLW, and TRU wastes from offsite to Hanford; shipments of TRU wastes from Hanford to WIPP; and the shipment of construction and capping materials. The methods and data used in this analysis are described in detail in Volume II, Appendix H.

The types of potential transportation impacts evaluated and the approaches taken to quantify the transportation impacts are summarized in the following paragraphs.

**Radiological impacts of routine (incident-free) transport.** These potential impacts result from routine or incident-free transportation of radioactive materials where the shipments arrive at their destinations without release of the shipment's contents. The potential impacts would result from exposure of truck crews and populations on or near the highways to low levels of radiation emitted from shipping containers containing radioactive materials. The RADTRAN 5 computer code (Neuhauser et al. 2003) was used to estimate the potential impacts of incident-free transportation of waste materials. Route data were developed using the TRAGIS computer code (Johnson and Michelhaugh 2000), the current version of which is based on the 2000 Census. Because most of the shipments would occur in the next decade, the population estimates were not adjusted over time.

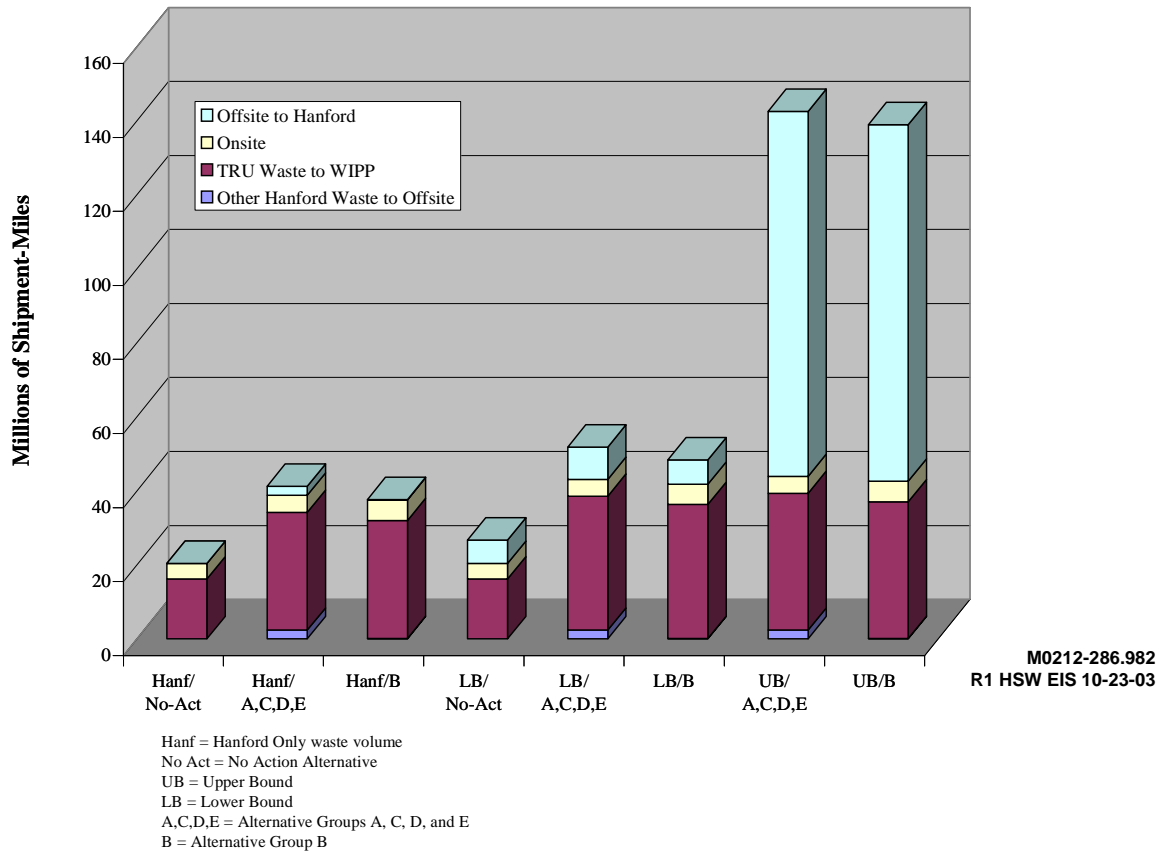
**Radiological impacts of vehicular accidents.** These potential impacts would result from accidental releases of radioactive material in transit. Accident impacts are determined by combining the probabilities and consequences of potential transportation accidents, ranging from minor to severe accidents, and then integrating them over the entire shipping campaign. The RADTRAN 5 computer code was used to quantify these impacts. An analysis of the impacts of severe but highly unlikely TRU waste accidents is also presented (see Volume II, Appendix H, Section H.3.2.3.2). Given the range of accidents and the resulting impacts analyzed in this EIS, these impacts were considered to also represent those that could occur from a terrorist attack (see Volume II, Appendix H, Section H.8).

**Non-radiological impacts of routine (incident-free) transportation.** Non-radiological impacts of routine transportation are the potential health effects that would result from routine emissions of hydrocarbon pollutants and dust from the truck tractors used to haul waste and capping and construction materials. These non-radiological impacts are estimated using a unit-factor approach (that is, latent cancer fatalities per kilometer) using data from Biber and Butler (1999).

**Non-radiological impacts of vehicular accidents.** The metric used for these potential impacts is the number of fatalities that would result from physical trauma as a result of vehicular accidents involving the heavy trucks used to transport waste and construction and capping materials. A unit-factor approach based on accidents and fatalities per kilometer was used to estimate these non-radiological accident impacts. Unit-factor data were taken from Green et al. (1996) for onsite shipments and from Saricks and Tompkins (1999) for offsite shipments.

**Hazardous chemical impacts of vehicular accidents.** These potential impacts would result from accidental releases of hazardous chemical constituents contained in mixed waste (including TRU mixed waste). A maximum credible accident approach was used to estimate the impacts. Hazardous chemical release and atmospheric dispersion calculations were performed to determine the maximum downwind concentration from a postulated maximum credible accident to which an individual might be exposed. The downwind concentrations were compared to safe exposure levels for each chemical to determine the potential public and worker impacts. These potential impacts were considered to also represent those that could occur from a successful terrorist attack.

Figure 5.27 illustrates the number of shipment-miles for each waste volume and alternative group. In general, the Hanford Only waste volume for the No Action Alternative results in the fewest shipment-miles because the volume of TRU wastes shipped offsite is lowest for the No Action Alternative and there are no shipments to Hanford from offsite. The Upper Bound waste volume for the action alternative groups results in the highest shipment-miles because of the relatively large volumes of TRU wastes shipped from Hanford to WIPP and offsite LLW, MLLW, and TRU wastes shipped to Hanford.



**Figure 5.27.** Shipment-Miles for Onsite and Offsite Waste Shipments



Table 5.25 presents the results, for the Hanford Only waste volume, of the analysis of potential transportation impacts of shipping LLW, MLLW, TRU wastes, and ILAW onsite, and shipping small volumes of LLW and MLLW to offsite treatment facilities and back. All of the impacts provided in Table 5.25 are in fatalities, except for the estimated number of traffic accidents. Fatalities are expressed in terms of latent cancer fatalities (LCFs) for radiological impacts and routine non-radiological emissions and in terms of trauma-induced fatalities for non-radiological accidents. (Many of the entries in the table are expressed as fractional fatalities, for example, 1E-01 or 0.1 fatalities. However, fatalities occur only as whole numbers and the totals have been obtained by rounding to the nearest whole number.)

**Table 5.25.** Summary of Potential Radiological and Non-Radiological Transportation Impacts - Hanford Only Waste Volumes, All Alternative Groups<sup>(a)(b)</sup>

Waste Type	Radiological Impacts, LCFs			Total Number of Accidents	Non-Radiological Impacts	
	Occupational	Non-Occupational	Radiological Accidents		Accident Fatalities	Emissions, LCFs
<b>Alternative Groups A, C, D, E</b>						
LLW	6E-03	4E-02	3E-06	7.1E-01	3.1E-02	3E-02
MLLW	2E-02	1E-01	2E-06	1.8	4.7E-02	2E-01
TRU	3E-03	3E-02	7E-06	9.1E-02	3.9E-03	4E-03
ILAW	5 E-03	7E-02	2E-09	5.4E-02	2.3E-03	3E-03
<b>Total</b>	0 (3.8E-02)	0 (2E-01)	0 (1E-05)	3 (2.6)	0 (8.5E-02)	0 (2E-01)
<b>Alternative Group B</b>						
LLW	6E-03	4E-02	3E-06	7.1E-01	3.1E-02	3E-02
MLLW	2E-03	1E-02	2E-07	2.8E-01	1.0E-02	2E-02
TRU	3E-03	3E-02	7E-06	9.1E-02	3.9E-03	4E-03
ILAW	5E-02	7E-01	2E-08	5.4E-01	2.3E-02	3E-02
<b>Total</b>	0 (6E-02)	1 (8E-01)	0 (1E-05)	2 (1.6)	0 (6.8E-02)	0 (8E-02)
<b>No Action Alternative</b>						
LLW	6E-03	4E-02	3E-06	7.1E-01	3.0E-02	3E-02
MLLW	3E-03	2E-02	7E-08	3.4E-01	1.5E-02	1E-02
TRU	3E-03	4E-02	9E-06	1.1E-01	4.7E-03	5E-03
ILAW	Intrafacility Transfer					
<b>Total</b>	0 (1E-02)	0 (9E-02)	0 (1E-05)	1 (1.2)	0 (5.0E-02)	0 (5E-02)
<b>Note:</b> Totals are rounded to one significant figure. Due to rounding, the sums of the numbers in the table may not exactly match the totals.						
(a) Table 5.25 presents the results, for the Hanford Only waste volume, of the analysis of the potential transportation impacts of shipping LLW, MLLW, TRU wastes, and ILAW onsite in addition to small volumes of Hanford LLW and MLLW offsite for treatment and back. This table does not include the potential transportation impacts of shipping TRU wastes from Hanford to WIPP for disposal. These potential impacts are presented in Table 5.26.						
(b) Radiological impacts (incident-free and accident) are expressed in units of latent cancer fatalities (LCFs). Non-radiological accident impacts are expressed as the expected number of accidents and the resulting non-radiological fatalities. Non-radiological emission impacts are expressed as LCFs.						

Table 5.25 indicates that the No Action Alternative results in the lowest total (that is, the sums across all waste types) potential onsite radiological impacts of all the alternative groups. This is primarily because, under the No Action Alternative, ILAW would be placed in concrete vaults adjacent to the Waste Treatment Plant (WTP) and, thus, is assumed not to involve transportation. The volume of TRU wastes shipped to WIPP is also lower for the No Action Alternative than for the action alternative groups. Of the action alternatives, Alternative Group B has the largest total potential radiological incident-free

impacts. Potential radiological incident-free impacts are dominated by the large volume and high number of shipments of ILAW to a disposal facility located in the 200 West Area. The potential radiological incident-free impacts associated with ILAW transportation are lower for Alternative Groups A, C, D, and E than for Alternative Group B, because in Alternative Groups A, C, D, and E, the shipping distance is shorter since the ILAW disposal facility is assumed to be located in the 200 East Area (the WTP is also located in the 200 East Area). None of the alternative groups was predicted to result in a radiological fatality from onsite shipments of TRU wastes and ILAW, including the Hanford Only waste volumes of MLLW and LLW that would be shipped to offsite treatment facilities and back.

Total non-radiological impacts are also lowest under the No Action Alternative. However, for the action alternatives, the potential impacts are larger for Alternative Groups A, C, D, and E than they are for Alternative Group B. This is because the potential non-radiological impacts are dominated by the shipments of MLLW to the Oak Ridge Reservation (ORR) for treatment and back. There are fewer shipments to ORR and back in Alternative Group B than in Groups A, C, D, and E. None of the action alternative groups was predicted to result in a non-radiological fatality from onsite shipments of solid waste, including the Hanford Only waste volumes of LLW and MLLW that would be shipped to offsite treatment facilities and back.

The potential impacts of shipments of solid waste to Hanford and shipments of TRU wastes from Hanford to WIPP are summarized in Table 5.26. Actual highway routes to and from Hanford were used in the analysis. The table presents the impacts of shipping LLW, MLLW, and TRU wastes from offsite to Hanford, and shipments of TRU wastes from Hanford to WIPP. For the Hanford Only and Lower Bound waste volumes, updated information was obtained from the Solid Waste Integrated Forecast Technical (SWIFT) report (Barcot 2002) to reflect the best available TRU waste volume projections for onsite and offsite (see Volume II, Appendix C). A recent study by DOE (DOE 2002c) to accelerate disposal of TRU wastes considered the creation of a “western hub” to certify TRU wastes from small-quantity sites for shipment to WIPP. Hanford is one of the sites being considered as a potential western hub. If Hanford is designated as a western hub, additional TRU wastes may be shipped from small-quantity sites to Hanford for certification and temporary storage prior to shipment to WIPP for disposal. For purposes of the analysis in this HSW EIS, additional quantities of TRU wastes assumed to be shipped to Hanford as a potential hub site are included in the Upper Bound waste volume, as discussed in Volume II, Appendix C.

As shown in Table 5.26, shipments of the Hanford Only waste volume of TRU waste to WIPP under the No Action Alternative result in the lowest potential radiological impacts. The next highest potential radiological impacts were estimated for the Hanford Only waste volume of TRU waste shipments to WIPP for the action alternatives. There are only small differences between the potential radiological impacts for the Hanford Only (action alternatives) and the Lower Bound waste volumes. These differences in potential impacts are due to the small quantities of LLW, MLLW, and TRU wastes that would be shipped to Hanford and the small additional TRU waste volume that would be shipped from Hanford to WIPP under the Lower Bound waste volume case. The highest potential radiological impacts were estimated for the Upper Bound waste volume. The Upper Bound waste volume case results in higher potential impacts than the other alternative groups because of the LLW, MLLW, and the additional TRU wastes that would be shipped to Hanford and from Hanford to WIPP.

**Table 5.26.** Summary of Radiological and Non-Radiological Transportation Impacts for Offsite Shipments by Waste Type<sup>(a)</sup>

Waste Type	Radiological Impacts			Total Number of Accidents	Non-Radiological Impacts	
	Routine Transport, LCFs		Accidents, LCFs		Fatalities	Emissions LCFs
	Worker	Public	Public			
<b>Hanford Only Waste Volume (TRU Waste—No Action Alternative)</b>						
CH TRU to WIPP	0 (2E-01)	1 (1E+00)	0 (4E-03)	8 (8E+00)	0 (2.8E-01)	0 (2E-01)
<b>Hanford Only Waste Volume (TRU Waste—Action Alternatives)</b>						
CH TRU to WIPP	2E-01	2E+00	5E-03	1E+01	4E-01	2E-01
RH TRU to WIPP	1E-01	2E+00	3E-03	6E+00	2E-01	1E-01
Total	0 (3E-01)	4 (4.4)	0 (8E-03)	17 (17)	1 (5E-01)	0 (3E-01)
<b>Lower Bound Waste Volume</b>						
LLW to Hanford	3E-02	1E-01	3E-03	3E+00	1E-01	1E-01
MLLW to Hanford	2E-04	1E-03	5E-05	3E-02	8E-04	1E-03
CH-TRU Waste to Hanford	6E-05	6E-04	2E-06	4E-03	1E-04	2E-04
RH-TRU Waste to Hanford	1E-03	4E-02	3E-05	8E-02	3E-03	4E-03
TRU Wastes to WIPP	3E-01	4E+00	8E-03	2E+01	6E-01	3E-01
Total	0 (3E-01)	5 (4.5)	0 (1E-02)	20 (20)	1 (6E-01)	0 (4E-01)
<b>Upper Bound Waste Volume</b>						
LLW to Hanford	3E-01	1E+00	4E-03	3E+01	1E+00	1E+00
MLLW to Hanford	2E-01	6E-01	2E-04	2E+01	6E-01	5E-01
CH-TRU Waste to Hanford	4E-03	5E-02	1E-04	1E-01	8E-03	2E-02
RH-TRU Waste to Hanford	2E-03	7E-02	6E-05	1E-01	5E-03	1E-02
TRU Wastes to WIPP	3E-01	4E+00	8E-03	2E+01	6E-01	3E-01
Total	1 (7E-01)	6 (6.4)	0 (1E-02)	73 (73)	2 (2.3)	2 (1.9)
(a) Radiological impacts (incident-free and accident) are expressed in units of LCFs. Non-radiological accident impacts are expressed as the expected number of accidents and the resulting non-radiological fatalities. Non-radiological emissions impacts are expressed as LCFs.						

Also shown in Table 5.26, the potential non-radiological accident fatality estimates are zero for the Hanford Only waste volume TRU waste under the No Action Alternative, one for the Hanford Only waste volume of TRU waste under the action alternatives and the Lower Bound waste volume, and two for the Upper Bound waste volume. Potential non-radiological emissions impacts were two LCFs for the Upper Bound waste volume and zero for the other two volumes. (For perspective it may be noted that over the next 40 years in the United States, several million traffic fatalities would result from other causes.) Figure 5.28 illustrates the transportation routes used in this analysis. The potential impacts presented in this HSW EIS are similar in magnitude to those presented in the WM PEIS (DOE 1997a) and WIPP SEIS-II (DOE 1997b). See additional details in Volume II, Appendix H, Section H.9.



AMES - Ames Laboratory  
 ANL - Argonne National Laboratory  
 BETTIS - Bettis Laboratory  
 BMI - Battelle Memorial Institute  
 BNL - Brookhaven National Laboratory  
 ETEC - Energy Technology and Engineering Center  
 FERMIL - Fermi National Accelerator Laboratory  
 GE-VAL - General Electric Vallecitos Nuclear Center  
 GRAND-JN - Grand Junction Office  
 INEEL - Idaho National Engineering and Environmental Laboratory  
 ITRI - Inhalation Toxicology Research Institute  
 KNPL - Knolls Atomic Power Laboratory  
 LANL - Los Alamos National Laboratory  
 LBNL - Lawrence Berkeley National Laboratory  
 LLNL - Lawrence Livermore National Laboratory

MIT BATES - Bates Linear Accelerator Center  
 NTS - Nevada Test Site  
 ORNL - Oak Ridge National Laboratory  
 PADUCAH - Paducah Gaseous Diffusion Plant  
 PANTEX - Pantex Plant  
 PORTSMOUTH - Portsmouth Gaseous Diffusion Plant  
 PPPL - Princeton Plasma Physics Laboratory  
 PSNS - Puget Sound Naval Shipyard  
 ROCKY FLATS - Rocky Flats Field Office  
 SNL - Sandia National Laboratories  
 SLAC - Stanford Linear Accelerator Center  
 SPRU - Separations Process Research Unit  
 SRS - Savannah River Site  
 WEST VALLEY - West Valley Demonstration Project  
 WIPP - Waste Isolation Pilot Plant

Highways shown in gray are major transportation routes; those highlighted in green are specific routes evaluated for waste shipments in this HSW EIS.

M0212-0286.975  
 HSW EIS 09-05-03

**Figure 5.28.** Highway Routes used in the Analysis of Offsite Transportation Impacts

The analysis of maximally exposed individuals under routine transport conditions indicated that the largest individual exposures of non-truck crew members would be received by a service station attendant. The assumption that this same individual attends one-third of the shipments (assuming the service station is visited by all of the shipments and the attendant works one of three shifts per day) to and from Hanford resulted in a radiation exposure of about 0.84 rem (840 mrem) over an approximate 40-year period, resulting in a probability of a latent cancer fatality from this dose of about 0.0005 (that is, 5 chances in 10,000).

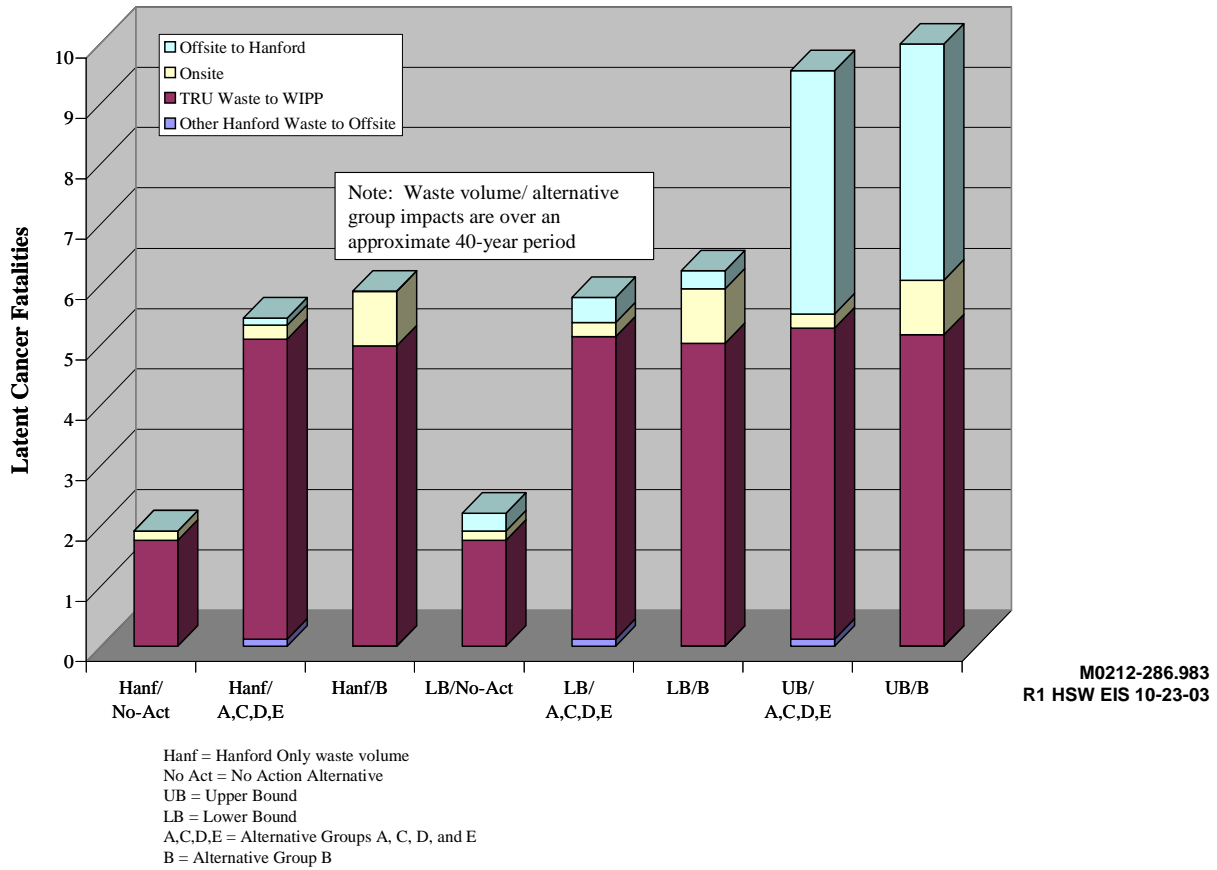
An evaluation (see Volume II, Appendix H, Section H.3.2.3.2) of the population and maximum individual exposures that could result from a severe transportation accident in a densely populated urban area was extracted from the WIPP SEIS-II (DOE 1997b). These estimates are pure consequence estimates; that is, the consequence estimates are not weighted by their probability of occurrence, which would be extremely small. These potential impacts were considered to also represent those that could occur from a terrorist attack (see Volume II, Appendix H, Section H.8). The analysis used bounding and average TRU waste inventories to develop a range of potential impacts. The bounding-case WIPP SEIS-II TRU waste inventories were used in the HSW EIS and are reflected in the impact estimates presented in Tables 5.25 and 5.26. The severe transportation accident analysis results demonstrated that, for the bounding TRU waste inventory case, up to 20 LCFs in the exposed population could be inferred. A maximum individual dose of about 125 rem was calculated, resulting in an inferred probability of a latent cancer fatality from this dose of about 0.08 (that is, 8 chances in 100). For the average inventory case, the respective impact estimates are about 4 inferred LCFs in the exposed population and an LCF probability of about 0.05 to the maximally exposed individual.

Table 5.27 provides estimates of the total shipment-miles and potential impacts for waste shipments within the Hanford Site, from offsite to Hanford, and from Hanford to offsite. The table illustrates that the impacts are approximately a function of the total distance traveled. Shipments from Hanford to offsite (which include a small number of LLW and MLLW shipments to offsite treatment facilities and back and shipments of TRU wastes from Hanford to WIPP) represent the largest impacts for all the waste transportation configurations shown in Table 5.27. The potential impacts of waste shipments from offsite to Hanford represent only a small fraction of the transportation impacts estimated for the Hanford Only and Lower Bound waste volumes. The potential impacts of offsite shipments to Hanford represent a substantial fraction of the total impacts of the Upper Bound waste volume case, but are still smaller than the impacts of shipments from Hanford to offsite facilities. The total potential latent cancer fatalities (sum of radiological incident-free impacts, radiological accident risks, and non-radiological emissions impacts) and non-radiological accident fatality estimates are illustrated in Figures 5.29 and 5.30, respectively.

The total projected radiation and emissions impacts in Table 5.27 range from about two to ten over the approximately 40 years of waste operations. For perspective, according to the U.S. Centers for Disease Control, National Center for Health Statistics, a total of 10,802 residents of the state of Washington and 7,057 residents of the state of Oregon died of cancer in 2001 (CDC 2003). The cancer mortality rates were 193 and 196 per 100,000 residents, respectively. A total of 36,245 residents of Washington and Oregon were estimated by TRAGIS to live within 800 meters of the highway route between Hanford and Ontario, Oregon. Based on a cancer mortality rate of 200 fatalities per year per 100,000 people, about 70 cancer fatalities per year, or about 2,800 cancer fatalities over a 40-year period,

**Table 5.27.** Summary of the Potential Transportation Impacts by Shipment Origin

	Hanford Only Waste Volume			Lower Bound Waste Volume			Upper Bound Waste Volume		
	No Action Alternative	Alternative Groups		No Action Alternative	Alternative Groups		No Action Alternative	Alternative Groups	
		A,C,D, E	B		A,C,D,E	B		A,C,D,E	B
<b>Millions of Shipment-Miles</b>									
Onsite	4.1	4.6	5.5	4.1	4.6	5.5	NA	4.6	5.5
Offsite Shipments to Hanford	<0.1	2.4	0.1	6.4	8.7	6.5	NA	98.5	96.3
Offsite Shipments from Hanford	16.2	34.2	32.0	16.2	38.5	36.3	NA	39.3	37.1
Total	20.4	41.1	37.6	26.7	51.8	48.3	NA	142.4	138.9
<b>Latent Cancer Fatalities<sup>(a)</sup></b>									
Onsite	0.15	0.23	0.9	0.15	0.23	0.90	NA	0.23	0.90
Offsite Shipments to Hanford	<0.001	0.12	0.0064	0.3	0.41	0.30	NA	4.0	3.9
Offsite Shipments from Hanford	1.8	5.1	5.0	1.8	5.1	5.0	NA	5.3	5.2
Total	2 (1.9)	5 (5.4)	6 (5.9)	2 (2.2)	6 (5.8)	6 (6.2)	NA	10 (9.5)	10 (10)
<b>Non-Radiological Accident Fatalities from Traffic Accidents</b>									
Onsite	0.05	0.055	0.067	0.05	0.055	0.067	NA	0.055	0.067
Offsite Shipments to Hanford	<0.0001	0.015	0.0008	0.11	0.13	0.12	NA	1.8	1.7
Offsite Shipments from Hanford	0.28	0.56	0.54	0.28	0.56	0.55	NA	0.58	0.56
Total	0 (0.33)	1 (0.63)	1 (0.61)	0 (0.44)	1 (0.75)	1 (0.73)	NA	2 (2.4)	2 (2.4)
Note: Total LCFs and non-radiological accident fatalities are rounded to one significant figure. Due to rounding, the sums of the numbers in the table may not exactly match the totals.									
(a) These values are the sums of the potential LCFs from incident-free radiological exposures, probability-weighted radiological accident risks, and incident-free non-radiological emissions.									
NA = not applicable.									

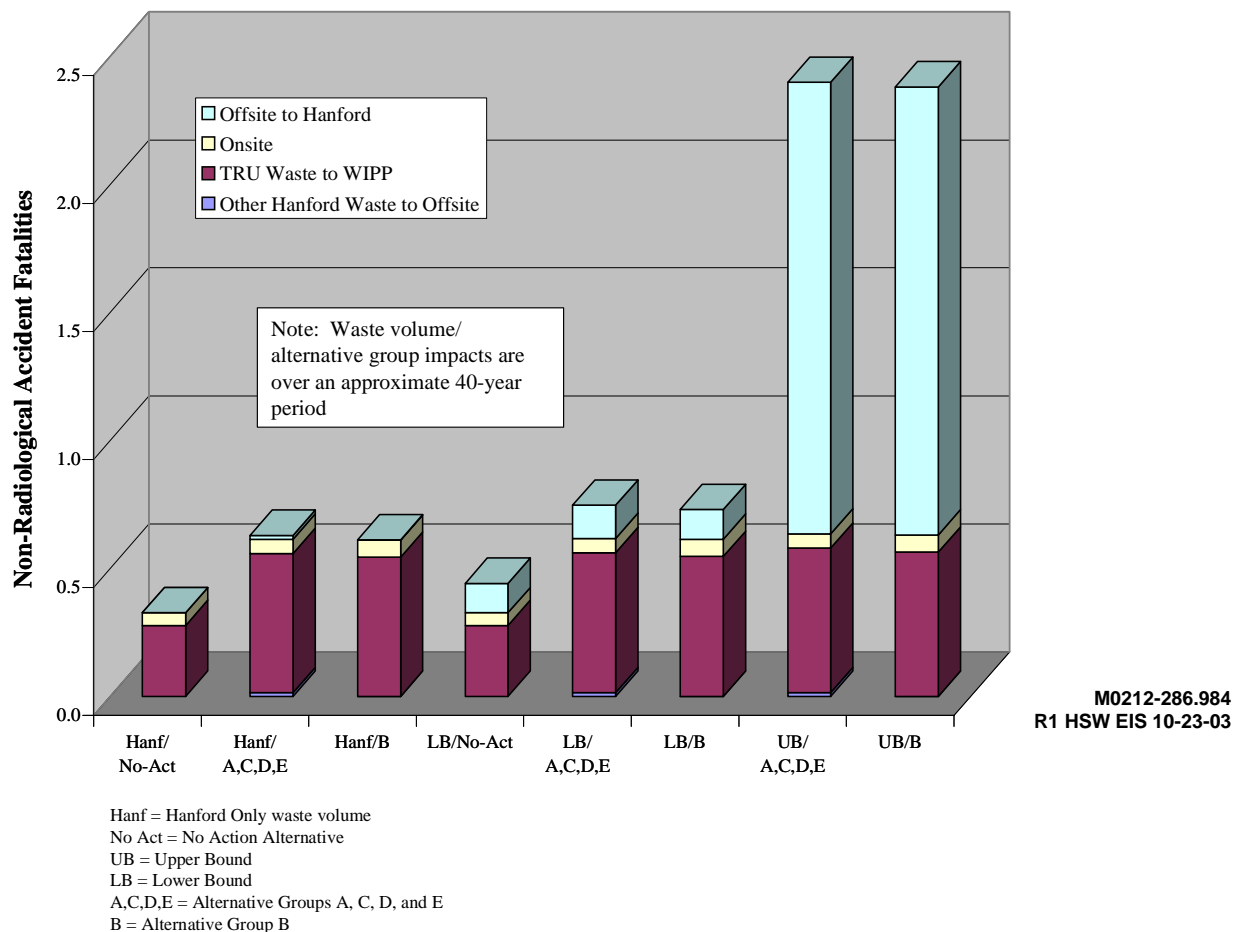


**Figure 5.29.** Potential Transportation Impacts of Onsite and Offsite Waste Shipments—LCFs from Radiological Incident-Free Transport, Radiological Accidents, and Non-Radiological Emissions<sup>(a)</sup>

would be estimated in the population along the route from Hanford to Ontario, Oregon, due to causes unrelated to shipments of waste to and from Hanford. The projected LCFs from the shipments of waste to and from Hanford would not be discernible.

For additional perspective, according to the U.S. Department of Transportation, National Highway Traffic Safety Administration, there were a total of 649 traffic fatalities in the state of Washington and 488 traffic fatalities in the state of Oregon for a total of 1,137 fatalities in the two states combined for 2001 (DOT 2002). This represents about 3 traffic fatalities per day in the 2 states. This can be compared to the total projected impacts of about 2 traffic fatalities over about 40 years for the Upper Bound waste volume shipments. Therefore, the total number of projected traffic fatalities from 40 years of transporting

(a) Although fatalities should be expressed as whole numbers, fractional fatalities are presented to facilitate illustration. Elsewhere fractional fatalities of 0.5 and greater are rounded up to the next whole number.



**Figure 5.30.** Shipment Mileages and Potential Transportation Impacts of Onsite and Offsite Waste Shipments—Non-Radiological Accident Fatalities<sup>(a)</sup>

solid waste to, from, and within Hanford is approximately the same as the traffic fatalities that occur, on average, every day in the states of Washington and Oregon. The incremental traffic fatalities from the waste shipments would not be discernible.

The HSW EIS, in addition to presenting a revised nationwide transportation analysis based on actual routes and 2000 Census information, also presents, in response to comments, the potential impacts for the states of Washington and Oregon. Three actual routes through Washington and Oregon were analyzed in this EIS for LLW, MLLW, and TRU wastes (see Figure 5.31). These include a route that enters Oregon from the east on Interstate-84 (I-84) near Ontario, Oregon, and one that enters Oregon from the south on I-5 near Ashland, Oregon. For the Lower Bound waste volume, the Ontario route would be used for about 9,500 shipments, and the Ashland route would be used for about 180 shipments. For the Upper

(a) Although fatalities should be expressed as whole numbers, fractional fatalities are presented to facilitate illustration. Elsewhere fractional fatalities of 0.5 and greater are rounded up to the next whole number.





M0212-0286.679  
R3 HSW EIS 8-19-03

**Figure 5.31.** Shipping Routes in Washington and Oregon

Bound waste volume, the Ontario route would be used for about 34,000 shipments, and the Ashland route would be used for about 1,100 shipments. These estimates include LLW, MLLW, and TRU waste shipments from offsite to Hanford and TRU waste shipments from Hanford to WIPP. For the Hanford Only waste volume, there would be approximately 8,200 shipments of TRU wastes to WIPP for the action alternatives and approximately 4,200 shipments for the No Action Alternative. All of these shipments would use the Ontario, Oregon, route. A third route is included for one MLLW shipment from Puget Sound Naval Shipyard to Hanford via I-90 and I-82. A northern route that enters Washington near Spokane on I-90 was not used in this analysis. Based on actual practice, shipments from midwestern and eastern generators were assumed to travel across country on more southerly routes (that is, I-80 and I-84) to avoid severe winter weather and minimize shipping distances and times.

The waste shipments to Hanford will predominately travel on interstate highways. Only in extremely rare instances would interstate highway or bridge construction lead to a detour through municipal streets. The waste shipments will be conducted using heavy-combination trucks but are not "overweight" vehicles that require special permits. The weights of the trucks that haul the waste to Hanford will be below legal-weight limits, similar to the vast majority of tractor-trailer vehicles that carry cargo on the interstates every day. In addition to the precautions taken by DOE during loading, trucks are subject to weighing and inspecting by state agencies as required.

If a waste shipment encounters a highway or bridge repair situation, it would stay on the interstate wherever possible and would typically not be detoured through cities along the route. If construction/repair of a bridge is taking place, traffic would be detoured to the opposite side of the freeway from where construction/repair is taking place - the open half of the freeway would temporarily become a two-way road. If an entire bridge were to be closed, the most common procedure would be to have traffic exit the freeway at the interchange immediately before the bridge and enter the freeway on the other side of the bridge at the same interchange or at the next entrance. In such cases, having a small number of shipments travel a short distance on routes other than the interstate freeways would not substantially change the transportation risks or conclusions presented in the HSW EIS.

The results of this analysis are presented in Table 5.28. Further details, including shipments and potential impacts by waste type, are presented in Volume II, Appendix H. Note that one radiological fatality was calculated for the Lower Bound waste volume, primarily due to shipments from Hanford to WIPP. The potential impacts are dominated by TRU waste shipments from Hanford to WIPP. Due to the higher volume of LLW and MLLW shipments in the Upper Bound waste volume than the Lower Bound waste volume, the impact estimates are higher; that is, one radiological fatality and one non-radiological fatality from traffic accidents are predicted. There are approximately equal contributions to these potential impact estimates from LLW and MLLW shipments to Hanford and TRU waste shipments from Hanford to WIPP. The full analysis of the potential impacts of transporting LLW, MLLW, and TRU wastes from offsite to Hanford are contained in Volume II, Appendix H of this EIS. The routes used in these analyses and the data used to calculate the impacts include some areas with relatively high traffic hazards, such as Cabbage Hill on I-84 in Oregon. Refer to Section 2.2.4 for further information on emergency preparedness for transportation accidents involving radioactive materials.

The impacts of transporting construction and capping materials to solid waste management facilities on the Hanford Site are summarized in Table 5.29. The materials that were included in the calculations included concrete, asphalt, gravel/sand, silt/loam, basalt, bentonite, and steel. Although some accidents were predicted to occur, there were no predicted fatalities associated with transport of construction and backfill materials. The impacts of all alternative groups were found to be dominated by transport of gravel/sand, silt/loam, and basalt to use as capping materials. The impacts for the No Action Alternative were found to be dominated by the transport of steel and concrete.

The results of the hazardous chemical impact analysis are presented in Table 5.30. The results indicate that downwind concentrations of the hazardous chemicals would not exceed the Temporary Emergency Exposure Limit-2 (TEEL-2) guidelines following a severe transportation accident involving a shipment of maximum-inventory 208-L drums. Additional analyses were performed to determine the impacts of assuming that all of the released materials become volatilized under the thermal effects of a transportation-related fire. This was done by changing the release aerosol and respirable fractions of all of the chemicals to 1.0. This resulted in three chemicals exceeding their TEEL-2 concentrations—elemental lead, elemental mercury, and beryllium. The downwind concentrations of these three chemicals were then compared to their Immediately Dangerous to Life and Health (IDLH) values for additional perspective (see Volume II, Appendix H). The TEEL-2 and IDLH exposure guideline concentrations are defined as follows:

**TEEL-2:** The maximum concentration in air below which it is believed nearly all individuals could be exposed without experiencing or developing irreversible or other serious health effects or symptoms that could impair their abilities to take protective action.

**IDLH:** The maximum concentration from which, in the event of respirator failure, a person could escape within 30 minutes without a respirator and without experiencing any escape-impairing (for example, severe eye irritation) or irreversible health effects.

The downwind concentrations of all chemicals are well below their respective IDLH values. Based on these observations, the conclusion was that releases of hazardous chemicals from possible transportation accidents involving waste materials would be unlikely to result in a fatality. These consequence estimates for a severe transportation accident were also considered to represent the potential impacts of a successful terrorist attack which, based on this analysis, would not be expected to result in catastrophic or wide ranging impacts due to release of chemically hazardous waste constituents.

**Table 5.28.** Impacts in Oregon and Washington by State from Shipments of Solid Wastes to and from Hanford<sup>(a)</sup>

Waste Volume/ Alternative Group	Radiological Impacts, LCFs			Total Number of Accidents	Non-Radiological Impacts	
	Routine Transport		Accidents		Number of Fatalities	Emissions LCFs
	Worker	Public	Public			
<b>Oregon State</b>						
Hanford Only – Action Alternatives <sup>(b)</sup>	0 (0.026)	0 (0.34)	0 (4.2E-4)	1 (1.2)	0 (0.11)	0 (0.023)
Lower Bound – All Alternatives	0 (0.029)	0 (0.37)	0 (7.7E-4)	1 (1.4)	0 (0.14)	0 (0.037)
Upper Bound – Action Alternatives	0 (0.074)	1 (0.59)	0 (4.7E-3)	5 (5.1)	0 (0.48)	0 (0.16)
Hanford Only – No Action Alternative <sup>(b)</sup>	0 (0.013)	0 (0.11)	0 (2.2E-4)	1 (0.60)	0 (0.057)	0 (0.012)
<b>Washington State</b>						
Hanford Only – Action Alternatives <sup>(b)</sup>	0 (8.0E-3)	0 (0.11)	0 (1.3E-4)	0 (0.38)	0 (8.2E-3)	0 (0.036)
Lower Bound – All Alternatives	0 (8.9E-3)	0 (0.11)	0 (2.1E-4)	0 (0.46)	0 (9.7E-3)	0 (0.042)
Upper Bound – Action Alternatives	0 (0.022)	0 (0.17)	0 (1.2E-3)	2 (1.6)	0 (0.034)	0 (0.15)
Hanford Only – No Action Alternative <sup>(b)</sup>	0 (4.2E-3)	0 (0.036)	0 (7.0E-5)	0 (0.20)	0 (4.2E-3)	0 (0.018)
<p>(a) Radiological impacts (incident-free and accident) are expressed in units of LCFs. Non-radiological accident impacts are expressed as the expected number of accidents and the resulting physical trauma fatalities. Non-radiological emissions impacts are expressed as LCFs.</p> <p>(b) TRU wastes to WIPP.</p>						

**Table 5.29.** Impacts of Transporting Construction and Capping Materials

<b>Alternative Group</b>	<b>Waste Volume</b>	<b>Total Distance Traveled, millions of miles</b>	<b>Number of Accidents</b>	<b>Number of Fatalities</b>
A	Hanford Only	8.4	2 (1.5)	0 (6E-02)
	Lower Bound	8.5	2 (1.5)	0 (6E-02)
	Upper Bound	9.4	2 (1.6)	0 (7E-02)
B	Hanford Only	11	2 (1.9)	0 (8E-02)
	Lower Bound	11	2 (2.0)	0 (8E-02)
	Upper Bound	15	3 (2.6)	0 (1.-01)
C	Hanford Only	7.9	1 (1.4)	0 (6E-02)
	Lower Bound	8.0	1 (1.4)	0 (6E-02)
	Upper Bound	8.9	2 (1.6)	0 (7E-02)
D	Hanford Only	7.9	1 (1.4)	0 (6E-02)
	Lower Bound	8.0	1 (1.4)	0 (6E-02)
	Upper Bound	8.9	2 (1.6)	0 (7E-02)
E	Hanford Only	7.9	1 (1.4)	0 (6E-02)
	Lower Bound	8.0	1 (1.4)	0 (6E-02)
	Upper Bound	8.8	2 (1.5)	0 (7E-02)
No Action	Hanford Only	20	4 (3.5)	0 (2E-01)
	Lower Bound	20	4 (3.5)	0 (2E-01)
<p><b>Note:</b> The materials that were included in the impact analysis were concrete, asphalt, gravel/sand, silt/loam, basalt, bentonite, and steel. Gravel/sand, silt/loam, and basalt were assumed to be transported from Area C on the Hanford Site. Various offsite locations were considered to be the sources for the other materials.</p>				

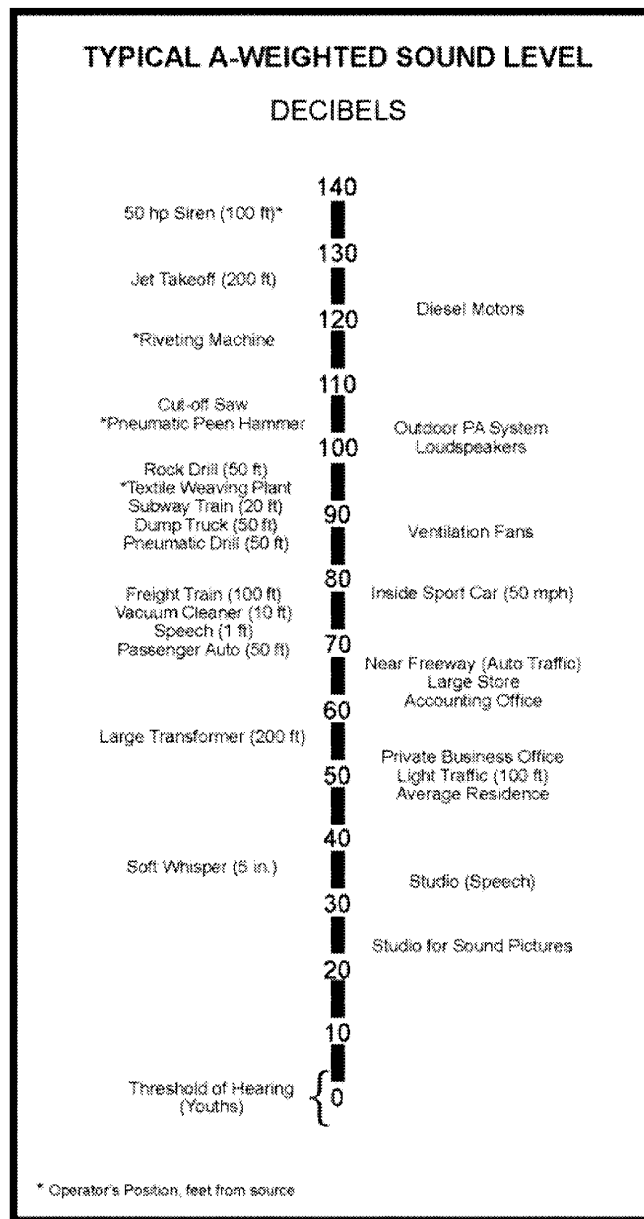
**Table 5.30.** Hazardous Chemical Concentrations (mg/m<sup>3</sup>) 100 m (109 yd) Downwind from Severe Transportation Accidents<sup>(a)</sup>

Chemical	CH MLLW	RH MLLW	MLLW Ready for Disposal	RH TRU Boxes	CH TRU with PCBs	RH TRU in Trenches	Elemental Lead	Elemental Mercury	TEEL-2
Acetone	6.9E-03	6.7E-03	6.9E-03	2.6E-05	0	0	0	0	20,000
Beryllium	8.9E-04	8.9E-04	8.9E-04	8.4E-05	8.4E-05	8.4E-05	0	0	0.025
Bromodichloro-methane	3.9E-05	0	3.9E-05	0	0	0	0	0	30
Carbon tetrachloride	1.4E-02	0	1.4E-02	4.5E-03	0	0	0	0	639
Diesel fuel	2.7E-05	0	2.7E-05	0	0	0	0	0	500
Formic acid	3.2E-02	0	3.2E-02	0	0	0	0	0	15
Lead	0	0	0	0	0	0	1.6E-01	0	0.25
Methyl ethyl ketone (MEK or 2 Butanone)	5.4E-03	0	5.4E-03	0	0	0	0	0	750
Mercury	8.3E-06	0	8.3E-06	8.1E-07	0	0	0	2.3E-02	2.05
Nitrate	7.8E-03	0	0	0	0	0	0	0	50
Nitric acid	2.3E-01	2.3E-01	2.3E-01	0	0	0	0	0	15
Polychlorinated biphenyls (PCBs)	9.7E-05	0	9.7E-05	0	3.0E-04	0	0	0	1
p-Chloroaniline	1.9E-02	0	1.9E-02	0	0	0	0	0	50
Sodium hydroxide	3.2E-01	3.2E-01	3.2E-01	1.7E-02	1.7E-02	1.7E-02	0	0	5
Toluene	1.2E-02	3.6E-01	1.2E-02	0	0	0	0	0	1,125
1,1,1-Trichloroethane	2.5E-02	0	2.5E-02	2.6E-05	0	0	0	0	3,850
Xylene	2.1E-03	3.4E-02	2.1E-03	1.4E-04	1.6E-01	1.6E-01	0	0	750

(a) The results presented in this table were calculated assuming a 0.5% respirable release fraction for solid materials and 100% release for volatiles. Assuming a 100% release for all chemicals causes three chemicals, including beryllium, lead, and mercury, to exceed TEEL-2 concentrations. See Volume II, Appendix H, Section H.7 for additional details.

## 5.9 Noise

Noise is defined technically as sound that is unwanted and perceived as a nuisance by humans. Within the context of this HSW EIS, the public represents human habitations located adjacent to the boundary of the Hanford Site and communities bordering roads that may support material and waste shipments to and from the site. An understanding of noise impacts is facilitated by associating noise levels with common activities or sources (see Figure 5.32).



MO212-0286.732  
RI HSW EIS 03-27-03

**Figure 5.32.** Association of Noise Levels with Common Sources or Activities

Potential impacts of noise on the public from implementing the alternative groups are addressed in the following sections. The analytical methods used to arrive at the conclusions drawn in this section are presented in Volume II, Appendix J.

In the course of implementing any of the alternative groups, various waste management construction and operations activities would generate noise. The total work force associated with the alternative groups likely would not exceed 850, which would result in a minimal addition to traffic noise.

For protection of the public, Washington Administrative Code (WAC) 173-60 has established a limit for daytime residential noise levels of 70 decibels (dBA) and a nighttime limit of 50 dBA at industrial site boundaries. No actual human habitations would be located within 10 km (6.2 mi) of the boundary of the Industrial-Exclusive zone surrounding the 200 Areas or the Area C borrow pit south of SR 240, thus ensuring that WAC limits would not be exceeded.

The point of closest potential exposure to noise for the transient public near the 200 Areas is about 2 km (1.2 mi) distant on SR 240. However, only emergency turnouts exist on SR 240 in that vicinity, and any exposure to noise would be of short duration and below applicable standards.

Noise is defined in terms of human perception, but sound also can be disturbing to wildlife. Because wildlife can relocate freely to areas of less sound intrusion, no substantial adverse sound-based impacts from waste management activities are anticipated.

Although not considered noise in the above sense, a potential might exist for impacts from ground vibrations on research conducted at the Laser Interferometer Gravitational Wave Observatory (LIGO). The major source of such ground vibrations would be associated with excavation for capping materials in Area C where the closest distance to one of the LIGO detection arms is approximately 14 km (8.7 mi). The impacts, if any, would be similar for any of the alternative groups; however, these impacts have not been quantified.

### **5.9.1 Alternative Group A**

The principal activities associated with Alternative Group A (for the Hanford Only, Lower Bound, or Upper Bound waste volumes) would be modification of the T Plant Complex; construction of deeper and wider trenches; loading, backfilling, and closure of the LLBGs; operation of the WRAP, T Plant, and CWC; operation of pulse driers for MLLW leachate; onsite transport of construction materials and waste; transport of MLLW offsite for treatment; disposal of ILAW in a new disposal facility near the PUREX Plant; and transport of construction materials to the site. Noise emissions from construction equipment range from 75 to 89 dBA (see Table 5.31). Because of the distance from the sources of noise from these activities, noise levels would be less than applicable state standards at the nearest residence. The maximum calculated noise level at the nearest residence is 33 dBA, and this would be indistinguishable from background noise. Infrequent blasting of rock from the Area C borrow pit would not exceed applicable state standards at the nearest residence.



**Table 5.31.** Typical Noise Levels Associated with Construction Equipment<sup>(a)</sup> and Blasting<sup>(b)</sup>

<b>Equipment</b>	<b>Representative Noise Level (dBA) at 15 m (50 ft)</b>
Backhoe	80
Grader	85
Loader	85
Roller	75
Bulldozer	85
Truck	88
Scraper	89
Blasting	94 <sup>(c)</sup>
(a) FTA (1995).	
(b) Jones and Stokes (2002).	
(c) Noise level at 1200 m (4000 ft) is about 59 dBA.	

Material for capping LLBGs at closure would be acquired from the Area C borrow pit and would result in higher, but localized, noise levels from use of heavy equipment. In the absence of prolonged presence of the public in the vicinity, these noise levels likely would not result in a noticeable impact. Because there are no residential areas in the vicinity, state standards for noise would not be exceeded.

Incremental noise in communities through which waste is transported daily would be negligible when compared with background highway noise. Similarly, transport of construction material to the site and onsite would not result in substantial increases in traffic noise.

### 5.9.2 Alternative Group B

The principal activities associated with Alternative Group B (for either the Lower Bound or Upper Bound waste volumes) would be construction and operation of a new waste processing facility; construction of the current design, rather than deeper and wider trenches (as in Alternative Group A); loading, backfilling, and closure of the LLBGs; operation of the WRAP, T Plant Complex, and CWC; operation of pulse driers for MLLW leachate beginning in 2026; onsite transport of construction materials and waste; transport of MLLW offsite for treatment; disposal of ILAW in multiple, lined trenches in the 200 West Area; and transport of construction materials to the site. As in the case of Alternative Group A, noise levels resulting from these activities would be less than applicable state standards at the nearest residence.

The volume of capping materials required in Alternative Group B would be the largest among the alternatives. Although the activities would extend over a longer period of time, they would result in noise impacts similar to those described for Alternative Group A.

### **5.9.3 Alternative Group C**

Alternative Group C is very similar to Alternative Group A in terms of industrial activities and associated noise propagation. Noise levels associated with the implementation of this alternative group would be less than applicable state standards at the nearest residence. Moreover, noise levels would not differ substantially in magnitude or duration from those associated with Alternative Group A.

### **5.9.4 Alternative Groups D and E**

Except for excavation of capping materials, activities associated with Alternative Groups D and E are very similar to those of Alternative Group A, with only minor differences in scope and location of waste disposal. Noise levels associated with the implementation of these alternative groups would be less than applicable state standards at the nearest residence. They also would not differ substantially in magnitude or duration from those associated with Alternative Group A.

The volume of capping materials is less than for Alternative Group A. Hence, noise impacts indicated for Alternative Groups D and E would occur over a shorter period of time.

### **5.9.5 No Action Alternative**

The principal activities associated with the No Action Alternative would be the construction of 66 additional CWC buildings for storage of waste that cannot be certified for disposal; construction of additional LLW trenches of current design, loading, and backfilling; capping of two existing MLLW trenches; operation of the WRAP, T Plant Complex, and CWC; operation of pulse driers for MLLW leachate beginning in 2026; onsite transport of construction materials and waste; transport of MLLW offsite for treatment; disposal of ILAW as glass cullet in vaults near the PUREX Plant; and transport of construction materials to the site. Again, noise levels resulting from these activities would be less than applicable state standards at the nearest residence.

Less than 25 percent of the volume of capping materials would be required to cap the MLLW trenches and the ILAW. The noise levels associated with extraction of these materials from the borrow pit would be similar to those for Alternative Group A, but the activities would occur over a much shorter time.

## 5.10 Resource Commitments

Various energy and material resources would be committed in the implementation of any of the alternative groups. Estimates of major resources committed are summarized by alternative group in Table 5.32. (As a result of refined calculations of resource needs based on the Technical Information Document [FH 2004], the need for gravel and sand, silt/loam, and basalt for the action alternative groups increased by factors of approximately 1.8, 2.6, and 1.2, respectively, over those reported in the revised draft HSW EIS [DOE 2003].) In this section, Alternative Groups D<sub>1</sub>, D<sub>2</sub>, and D<sub>3</sub> are referred to collectively as Alternative Group D (and similarly for Alternative Groups E<sub>1</sub>, E<sub>2</sub>, and E<sub>3</sub>). The resource commitments for Alternative Groups D and E are considered collectively because the activities under each essentially are the same—only the locations of the activities change. The location changes do not significantly alter the resource commitments.

The ILAW resources are broken out separately at the bottom of Table 5.32 because the resource requirements to handle this one waste category can be much greater than those of the other categories. Resource estimates for management of melters are included with other Hanford solid waste streams. The ILAW vault resource commitments would be added to the No Action Alternative values, the ILAW multiple trench commitments would be added to values for Alternative Groups A and B, and the ILAW single trench commitments would be added to values for Alternative Groups C, D, and E. Resource commitments of the alternative groups with the appropriate ILAW actions included are presented in Table 5.32.

Resource requirements for a number of materials are larger for Alternative Group B than for Alternative Groups A, C, D, or E because of the less-efficient trench design. Some activities under the No Action Alternative require more resources than the action alternatives. Under the No Action Alternative, ILAW is disposed of in vaults, which increases the diesel, steel, concrete, and water needs. In addition, 66 CWC waste storage buildings would be constructed, which increases the steel and concrete needs compared with those for the other alternative groups. The use of accelerated process lines would be expected to require only minor amounts of resources, regardless of where placed.

When considering the resource commitments by inventory volume within an alternative group, the Hanford Only waste volume generally requires the least resources; the Upper Bound waste volume requires the most. In many cases, the Hanford Only and Lower Bound waste volume resource commitments are not substantially different.

The resource commitments presented in Table 5.33 for actions excluding ILAW would not be expected to impact available supplies or activities requiring these same resources. The peak electrical power required for construction of operations associated with the management of Hanford solid waste for any of the alternative groups would not be expected to impact Hanford's existing capacity. The commitment of resources for ILAW actions would not cause any impacts beyond those described in the *Hanford Comprehensive Land-Use Plan Environmental Impact Statement* (DOE 1999) and the Hanford Waste Management Operations EIS (ERDA 1975).

**Table 5.32.** Resource Commitment Summary by Alternative Group and for ILAW<sup>(a)</sup>

Waste Volume	Total Electric (GWhr)	Diesel (m <sup>3</sup> )	Gasoline (m <sup>3</sup> )	Propane (t)	Asphalt <sup>(b)</sup> (1000 m <sup>3</sup> )	Gravel/Sand (1000 m <sup>3</sup> )	Silt/Loam (1000 m <sup>3</sup> )	Basalt (1000 m <sup>3</sup> )	Bentonite Clay (t)	Steel (t)	Concrete (1000 m <sup>3</sup> )	Total Water (1000 m <sup>3</sup> )	Lead (t)	Land (ha)
<b>Alternative Group A (without ILAW)</b>														
Hanford Only	735	12,800	260	12,700	362	776	1,900	518	13,900	720	8.0	488	45	143
Lower Bound	735	12,800	260	12,700	364	782	1,910	521	13,900	870	9.6	488	45	144
Upper Bound	743	13,600	270	19,300	386	828	2,030	552	18,200	1,280	14	492	45	152
<b>Alternative Group B (without ILAW)</b>														
Hanford Only	5860	16,500	340	23,500	408	881	2,160	587	33,600	800	9.9	484	45	161
Lower Bound	5860	16,500	340	23,500	414	895	2,190	597	33,600	950	12	485	45	163
Upper Bound	587	20,500	430	38,300	468	1010	2,470	673	57,600	1,380	16	487	45	184
<b>Alternative Group C (without ILAW)</b>														
Hanford Only	735	12,800	260	12,700	362	776	1,900	518	13,900	720	8.0	488	45	143
Lower Bound	735	12,800	260	12,700	364	782	1,910	521	13,900	870	9.6	488	45	144
Upper Bound	743	13,600	270	19,300	386	828	2,030	552	18,200	1,280	14	492	45	152
<b>Alternative Group D (without ILAW)</b>														
Hanford Only	735	12,800	260	18,800	380	821	2,010	548	13,900	710	8.0	488	45	142
Lower Bound	735	12,800	260	20,300	382	824	2,020	549	13,900	870	9.9	488	45	142
Upper Bound	743	13,600	270	27,800	394	850	2,080	567	18,200	1,280	14	492	45	147
<b>Alternative Group E (without ILAW)</b>														
Hanford Only	735	12,800	260	18,800	360	772	1,890	515	13,900	710	8.0	488	45	142
Lower Bound	735	12,800	260	20,300	361	775	1,900	516	13,900	870	9.9	488	45	142
Upper Bound	743	13,600	270	27,800	373	801	1,960	534	18,200	1,280	14	492	45	147
<b>No Action Alternative (without ILAW)</b>														
Hanford Only	685	5,200	48	3,560	6	13	31	8	0	25,900	140	29.6	45	148
Lower Bound	685	5,300	50	3,560	6	13	31	8	0	26,000	142	29.6	45	149
<b>ILAW</b>														
Vault	NA	183,400	NA	0	20	2603 <sup>(c)</sup>	NA	NA	NA	33,170	282	487	0	10
Multiple Trench	NA	120,100	NA	0	33	770 <sup>(c)</sup>	NA	NA	NA	1,000	0.31	789	0	26
Single Trench	NA	53,100	NA	0	10	550 <sup>(c)</sup>	NA	NA	NA	1,000	0	308	0	8
(a) Conversion factors: 1 m <sup>3</sup> (capacity) = 260 gal; 1 m <sup>3</sup> (volume) = 1.3 yd <sup>3</sup> ; and 1 t (metric tonne) = 1.1 tons.														
(b) A fully prepared product including its components.														
(c) Total fill (sand, gravel, silt, and rip rap).														
NA = not applicable.														

**Table 5.33. Resource Commitment Summary by Alternative Group with ILAW Resources Included<sup>(a)</sup>**

<b>Waste Volume</b>	<b>Diesel (m<sup>3</sup>)</b>	<b>Asphalt (1000 m<sup>3</sup>)</b>	<b>Gravel/Sand, Silt/Loam, Basalt (1000 m<sup>3</sup>)</b>	<b>Steel (t)</b>	<b>Concrete (1000 m<sup>3</sup>)</b>	<b>Total Water (1000 m<sup>3</sup>)</b>
<b>Alternative Group A</b>						
Hanford Only	132,900	392	3,960	1,720	8.3	1,280
Lower Bound	132,900	394	3,990	1,870	9.9	1,280
Upper Bound	133,700	416	4,180	2,280	14	1,280
<b>Alternative Group B</b>						
Hanford Only	136,600	438	4,400	1,800	10	1,270
Lower Bound	136,700	444	4,450	1,950	12	1,270
Upper Bound	140,600	498	4,930	2,380	16	1,280
<b>Alternative Group C</b>						
Hanford Only	65,900	372	3,740	1,720	8.0	798
Lower Bound	65,900	374	3,770	1,870	9.6	798
Upper Bound	66,700	396	3,960	2,280	14	802
<b>Alternative Group D</b>						
Hanford Only	65,900	390	3,930	1,710	8.0	798
Lower Bound	65,900	392	3,940	1,870	9.9	798
Upper Bound	66,700	404	4,050	2,280	14	802
<b>Alternative Group E</b>						
Hanford Only	65,900	370	3,730	1,710	8.0	798
Lower Bound	65,900	371	3,740	1,870	9.9	798
Upper Bound	66,700	383	3,850	2,280	14	802
<b>No Action Alternative</b>						
Hanford Only	188,600	26	2,650	59,100	420	520
Lower Bound	188,700	26	2,650	59,200	422	520
(a) Conversion factors: 1 m <sup>3</sup> (capacity) = 260 gal; 1 m <sup>3</sup> (volume) = 1.3 yd <sup>3</sup> ; and 1 t (metric tonne) = 1.1 tons.						

## 5.11 Human Health and Safety Impacts

Potential health impacts to workers and the public are presented in this section. The methods used to estimate health impacts from radiological and chemical sources are described in Volume II, Appendix F. The health impacts included in this section are those related to

- airborne release of radionuclides and chemicals from routine and accident conditions (excluding transportation)
- waterborne releases (via groundwater) over the long term
- construction activities
- operations
- fugitive releases of criteria pollutants
- inadvertent intrusion into disposal facilities.

Potential health effects included in this section are for the following populations of individuals:

- construction workers – workers involved with construction activities
- involved workers – workers directly involved in the activity being discussed
- non-involved workers – workers physically near the activity being discussed, but not directly involved in the activity
- maximally exposed individual (MEI) from atmospheric release – hypothetical member of the public who receives, through airborne emissions, the highest health impacts from onsite activities
- maximally exposed individual from waterborne releases – hypothetical member of the public who receives, through waterborne emissions, the highest health impacts from onsite activities
- local populations – the populations within 50 miles (80 km) of the center of the Hanford Site that are exposed to airborne releases
- downstream populations – the entire populations of Pasco, Kennewick, and Richland (Tri-Cities), Washington, and downstream populations represented by Portland, Oregon
- maximally exposed individual from inadvertent intrusion into disposal facilities – hypothetical individual receiving the highest impacts following inadvertent intrusion into the disposal facilities.

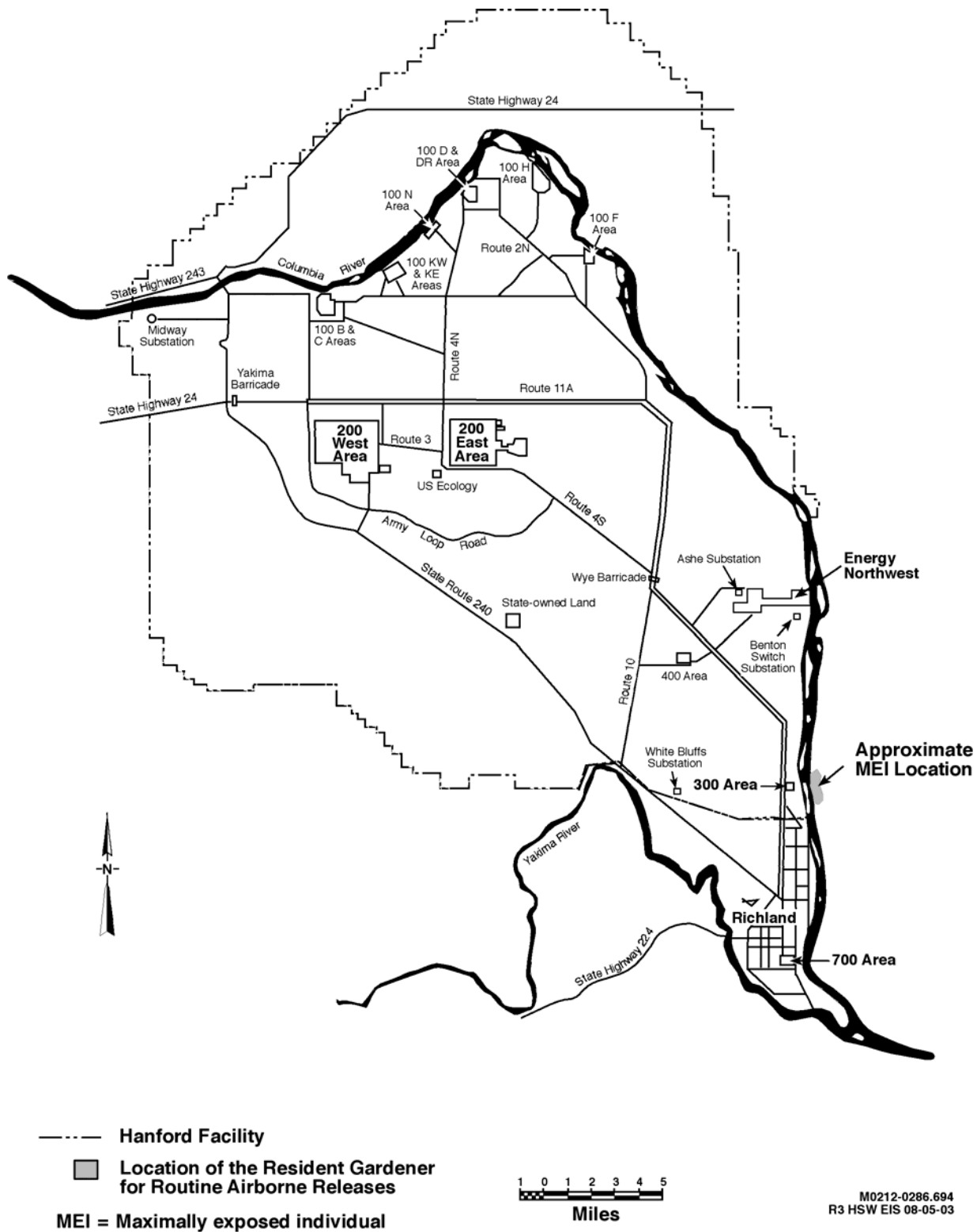
Impacts from construction activities include injuries to workers and impacts on air quality. Details of the air quality impact analysis for construction are presented in Section 5.2. The analysis of impacts on water quality (from waterborne releases to groundwater) is described in Section 5.3. Those sections compare air and water concentrations to appropriate limits. Results from those analyses have been extended to the estimates of human health impacts that are presented in this section. The analysis of impacts from potential releases and exposures to radionuclides and chemicals as a result of transportation of wastes is described in Section 5.8.

Health impacts are presented by alternative group and are based on conservative assumptions used in this EIS. The methods, assumptions, and related information for routine release assessment and accident analysis are provided in Volume II, Appendix F.

Construction worker injuries are estimated using standard construction worker accident rate information (described in Section 4.10) and the construction workforce projections for each facility that involve construction for a given alternative. The analysis includes all of the operations involving construction for each alternative. Consideration is also given to the type of construction activity (that is, heavy equipment operation versus building construction). Worker injuries during normal operations are evaluated using incident rates for industrial accidents.

Radiation doses as a total effective dose equivalent (TEDE) for workers involved in waste management activities were estimated using historical worker dose rates for Hanford facilities and the projection of the workforce involved (FH 2004).

Releases of radionuclides and chemicals to the atmosphere are evaluated for each solid waste facility based on the projected waste throughput volumes. Estimates of the annual release of pollutants to the atmosphere are made based on these processing volumes, the concentration of radionuclides and chemicals, and the release fractions for each facility. These release rates are used to estimate air concentrations at points of maximum exposure for the onsite worker and the offsite MEI. Individuals are assumed to be exposed to these transported pollutants through exposure pathways defined for each of two hypothetical exposure scenarios: industrial and resident gardener. The industrial scenario is used to evaluate the maximum health impacts for onsite, non-involved workers who are assumed to be located 100 m (329 ft) from the release point. This distance represents a reasonably close point for a permanent work location (for example, a nearby building) for an individual not associated with the facility from which the releases occur. The 100-m (329-ft) distance also allows for elevated release plumes to reach near the ground providing the potential for exposure for the individual (at shorter distances from the source the plume might miss the individual entirely). The resident gardener scenario is used to evaluate potential public exposures. For airborne releases, the resident gardener is an offsite individual located 20.6 km (13 mi) east-southeast of the 200 Areas, which is approximately across the Columbia River from the 300 Area. This location was chosen because it corresponds to the location of the MEI for recent sitewide releases of airborne effluents (see Figure 5.33). Consequences from accidental releases are based primarily on previously reported accident assessments for the facilities involved in the alternatives.



**Figure 5.33.** Location of the Resident Gardener for Routine Airborne Releases



Consequences of operating advanced processing lines (APLs) would be similar to those from processing TRU waste at WRAP, although timing of the consequences may vary from assumptions based on operating WRAP as the sole facility for processing TRU waste. If both WRAP and the APLs were to operate simultaneously, the annual impacts from atmospheric emissions could be somewhat greater than those estimated for WRAP alone, but they would persist for a shorter period of time. The total collective doses from operating one or more facilities to process TRU waste would be extremely small.

Releases of radionuclides and chemicals to the unsaturated soil beneath the Hanford solid waste disposal facilities in the 200 Areas would occur as the waste packages degrade and water seeps through the waste. The movement of pollutants from these releases to the affected environment has been analyzed and described in Section 5.3. Hypothetical future users of the groundwater downgradient from the waste disposal facilities on the Hanford Site might be exposed to contaminants in the water. Potential human health impacts from use of such groundwater were estimated for four locations, three located 1 km downgradient from the HSW disposal facilities and one near the Columbia River,<sup>(a)</sup> representative points of access by a hypothetical resident gardener after 2146 (in the absence of active institutional controls), and the location where the peak water concentrations are predicted. These locations (sites of hypothetical wells for evaluating groundwater use scenarios) correspond to points of analysis used for groundwater analyses as addressed in Section 5.3 and detailed in Volume II, Appendix G. A specific location is not defined because the location of the peak water concentration changes over time. For these locations, the resident gardener is assumed to live at the location and use the well as the source of all domestic and irrigation water. Details of these exposure scenarios are presented in Volume II, Appendix F, Section F.1.4.

The impacts to populations downstream from Hanford also were evaluated for the Tri-Cities region in Washington and for Portland, Oregon. The entire population of both areas was assumed to use the Columbia River as the sole source of drinking water (presently not the case for Portland nor the Tri-Cities). The population used for the Tri-Cities was 125,407 (MRSC 2001); for Portland, 538,180 (PSU 2002). The concentration in the river (used in the calculations) was based on the total amount of radionuclides reaching the river over the next 10,000 years, as evaluated for the water quality analysis in Section 5.3. To obtain the average concentrations of radionuclides in river water, the release to the river was diluted by the average Columbia River flow rate of about 3300 m<sup>3</sup>/sec for the Tri-Cities and about 5300 m<sup>3</sup>/sec for Portland.

- 
- (a) Although water might be drawn directly from the river for irrigation, it was assumed that well water would be used for domestic purposes.
  - (b) The National Council on Radiation Protection and Measurements continues to hold that a dose of 1 mrem/yr is a dose "below which efforts to reduce the radiation exposure to the individual are unwarranted" (Section 17 of NCRP 1993)" (NCRP 2000). Regardless, in this HSW EIS, doses are reported as calculated, however small they may be. Thus doses will be seen that are several to many orders of magnitude below 1 mrem/yr, and while these may be useful for comparative purposes, they should not be construed as having any physical meaning in terms of detriment to health.
  - (c) For an individual, the probability of an LCF cannot exceed one (certainty). Similarly, the number of LCFs among population groups occurs as whole numbers; the calculated value is given in parentheses. This calculated value represents an inferred incremental contribution to total cancer deaths in the exposed population.

Results of the consequence analyses are presented as annual radiation dose<sup>(b)</sup> and lifetime radiation dose for individual exposures, as well as collective radiation dose for population exposures. The associated human health impacts are represented as the lifetime risk of a latent cancer fatality (LCF)<sup>(c)</sup> based on Federal Guidance Report No. 13 (Eckerman et al 1999). Consistent with that guidance, a health effects coefficient of 0.0006 LCFs per person-rem TEDE was used to estimate the consequences of radiation exposure to both workers and members of the public. This coefficient is intended to apply to low radiation doses at low dose rates, which are typical of those received from most types of environmental exposures.

For some hypothetical radiological accidents discussed in the HSW EIS, the estimated dose to an onsite or offsite individual may be greater than the dose to which the health effects coefficient specified by Eckerman et al (1999) was intended to apply. Depending on the radionuclides involved and the exposure pathways considered, the LCF risk may be up to twice that indicated by the LCF conversion factors for doses greater than 20 rem but less than a few hundred rem. For doses greater than a few hundred rem, there is a potential for short-term health effects other than cancer and hereditary effects, again, depending on the radionuclides and exposure pathways associated with a particular accident scenario. Additional information on the basis for radiological health consequences is given in Volume II, Appendix F. For further discussion of related uncertainties see Section 3.5.

The routine operations health impacts from carcinogenic chemicals are presented as the lifetime risk of cancer incidence from exposure in the given scenario. For non-carcinogenic chemicals, the impacts are expressed as a hazard quotient. Both types of impacts are presented as the sum over all chemicals in the release of the given type. A hazard quotient of one represents an exposure level that is considered safe for most members of the population (EPA 1991). A value greater than one may represent an exposure that is detrimental to public health.

The health impacts to workers from chemicals due to accidents are evaluated by comparing chemical air concentrations with the emergency response planning guideline (ERPG) or the temporary emergency exposure limit (TEEL). These are described in Volume II, Appendix F. Although ERPGs are the official, preferred measure, ERPGs have not been established for many chemicals. Where ERPGs were not available, the TEELs were used.

The following sections present details of the human health impacts analyses for the six alternative groups considered in this HSW EIS. For a summary comparison of impacts among the alternatives, see Table 3.6 in Section 3.6. The impacts from the operational phase are presented for all alternative groups in Section 5.11.1, followed by the long-term health impacts resulting from contaminant transport through the groundwater (Section 5.11.2).

### **5.11.1 Operational Human Health and Safety Impacts**

The impacts from the operational phase are presented by alternative group in the following sections.

### **5.11.1.1 Alternative Group A**

The following sections present the potential human health impacts for Alternative Group A for the Hanford Only, Lower Bound, and Upper Bound waste volumes.

#### **5.11.1.1.1 Construction**

Primary impacts from construction activities would be air quality and injuries to construction workers. The construction activities would result in the emission of criteria pollutants (40 CFR 50) from the use of combustion engines and earthmoving activities. Impacts are measured by comparison of air concentrations with regulatory limits at the point of maximum potential public exposure. The air quality analysis (Section 5.2) indicates that maximum emissions of all criteria pollutants (including sulfur dioxide, carbon monoxide, nitrogen dioxide, and particulate material [PM<sub>10</sub>]) from construction activities would result in air concentrations below the regulatory limits. As a consequence, no impacts on public health from emissions would be expected. Impacts from industrial accidents during construction are discussed in Section 5.11.1.1.3.

#### **5.11.1.1.2 Normal Operations**

Potential impacts to public health from normal operations include impacts from atmospheric releases of radionuclides and chemicals from solid waste management operations. Radiation doses for workers involved with waste management operations are also evaluated.

Alternative Group A involves operations that may result in routine releases of radionuclides and chemicals to the atmosphere. These operations include waste package verification, treatment, and packaging at the Waste Receiving and Processing Facility (WRAP), treatment and packaging of waste at the modified T Plant Complex; and treatment of leachate from mixed low-level waste (MLLW) trenches using pulse driers. The annual releases have been estimated for each year of operation for the facilities involved in this alternative. Details of the release calculations are presented in Volume II, Appendix F, Section F.1.

##### **5.11.1.1.2.1 Health Impacts from Routine Radionuclide Releases**

Tables 5.34, 5.35, and 5.36 display the calculated doses and health impacts to non-involved workers and the public from routine atmospheric releases of radionuclides for the Hanford Only, Lower Bound, and Upper Bound waste volumes, respectively. The tables present the maximum annual dose to the non-involved workers and the public, the collective dose to the public, and the associated risk of LCF for these exposures occurring during the period covered by Alternative Group A. Given that the cancer risk estimates and doses are small in comparison to regulatory limits,<sup>(a)</sup> no adverse health impacts would be expected from radionuclide releases.

---

(a) The maximum annual radiation dose presented in this section may be compared to the regulatory limit of 10 mrem/year (WAC 246-247; 40 CFR 61; DOE 1993).

### 5.11.1.1.2.2 Health Impacts from Chemical Releases

Releases of chemicals to the atmosphere could occur from the same waste processes involving radionuclide release when wastes with hazardous chemicals are involved. The potential health impacts from chemical releases to the atmosphere are presented in Table 5.37 for all waste volumes. The results for the Hanford Only waste volume are the same as those for the Lower Bound waste volume because the processing volumes for mixed waste streams are nearly identical for both cases (only mixed wastes contain chemicals that may be released to the atmosphere). Because the peak hazard quotients are all less than 1, and because the cancer risk estimates are small, minimal adverse health impacts would be expected from chemical releases. Chemical releases from leachate treatment using a pulse drier are believed to be small compared with other processing (for example, WRAP) and are not included in the analysis of chemical health impacts.

**Table 5.34.** Non-Involved Worker and Public Health Impacts from Routine Atmospheric Releases of Radionuclides – Alternative Group A, Hanford Only Waste Volume

Exposed Group	Exposure Scenario <sup>(a)</sup>	Facility	Lifetime Dose <sup>(b)</sup> (mrem)	Probability of an LCF <sup>(c)</sup>	Maximum Annual Dose	
					Year	mrem
Worker Onsite (non-involved)	Industrial	WRAP	1.2E-03	7E-10	2004	1.3E-05
		Modified T Plant Complex	4.8E-01	3E-07	2003	3.9E-02
		Leachate Treatment <sup>(d,e)</sup>	4.3E-07	3E-13	2026	3.2E-09
MEI Offsite	Resident Gardener	WRAP	9.9E-05	6E-11	2004	1.1E-05
		Modified T Plant Complex	1.5E-03	9E-10	2003	1.1E-04
		Leachate Treatment	3.0E-11	2E-17	2026	1.6E-12
		Total	1.6E-03	1E-09	2003	1.2E-04
			<b>(person-rem)</b>	<b>Number of LCFs<sup>(f)</sup></b>	<b>Year</b>	<b>(person-rem)</b>
Population <sup>(g)</sup>	Population within 80 km (50 mi)	WRAP	9.1E-03	0 (5E-06)	2004	7.4E-04
		Modified T Plant Complex	1.4E-01	0 (8E-05)	2003	7.4E-03
		Leachate Treatment	2.1E-09	0 (1E-12)	2026	1.1E-10
		Total	1.5E-01	0 (9E-05)	2003	8.1E-03
<p>(a) The exposure duration for the industrial scenario is 20 years and for the resident gardener, 30 years. The exposure scenarios are described in Volume II, Appendix F.</p> <p>(b) The lifetime dose is the radiation dose received from intake during the exposure period and up to 50 years after exposure due to radionuclides deposited in the body during the exposure period.</p> <p>(c) LCF = latent cancer fatality.</p> <p>(d) Leachate treatment is a pulse drier operation.</p> <p>(e) If LLW trenches were to be lined, the doses from leachate collection and treatment might be as much as three times the leachate treatment values shown in this table.</p> <p>(f) The value in parentheses is the calculated value based on the population dose and the appropriate health effects conversion factor. The actual number of LCFs must be a whole number (deaths).</p> <p>(g) The population lifetime impacts are based on exposure for the same exposure pathways impacting the resident gardener MEI.</p>						

### 5.11.1.1.2.3 Worker Occupational Radiation Exposure

The radiation dose received by workers involved with waste operations is estimated using historical exposure data for the facilities involved in the alternative (FH 2004). The exposure to involved workers is summarized in Table 5.38 for the Hanford Only waste volume, in Table 5.39 for the Lower Bound waste volume, and in Table 5.40 for the Upper Bound waste volume. The worker category “Other” includes engineers, maintenance and construction personnel, and general support staff (for example, administrative and clerical workers). All estimated radiation doses to workers are well below regulatory limits.<sup>(a)</sup>

**Table 5.35.** Non-Involved Worker and Public Health Impacts from Routine Atmospheric Releases of Radionuclides – Alternative Group A, Lower Bound Waste Volume

Exposed Group	Exposure Scenario <sup>(a)</sup>	Facility	Lifetime Dose <sup>(b)</sup> (mrem)	Probability of an LCF <sup>(c)</sup>	Maximum Annual Dose	
					Year	mrem
Worker Onsite (non-involved)	Industrial	WRAP	1.4E-03	9E-10	2004	1.6E-04
		Modified T Plant Complex	5.8E-01	3E-07	2003	4.8E-02
		Leachate Treatment <sup>(d, e)</sup>	1.3E-07	8E-14	2026	7.4E-09
MEI Offsite	Resident Gardener	WRAP	1.2E-04	7E-11	2004	1.3E-05
		Modified T Plant Complex	1.7E-03	1E-09	2003	1.2E-04
		Leachate Treatment	6.8E-11	4E-17	2026	3.6E-12
		Total	1.8E-03	1E-09	2003	1.3E-04
			<b>(person-rem)</b>	<b>Number of LCFs<sup>(f)</sup></b>	<b>Year</b>	<b>(person-rem)</b>
Population <sup>(g)</sup>	Population within 80 km (50 mi)	WRAP	1.1E-02	0 (6E-06)	2004	8.8E-04
		Modified T Plant Complex	1.6E-01	0 (9E-05)	2003	8.5E-03
		Leachate Treatment	6.2E-09	0 (4E-12)	2026	2.5E-10
		Total	1.7E-01	0 (1E-04)	2003	9.4E-03
<p>(a) The exposure duration for the industrial scenario is 20 years and for the resident gardener, 30 years. The exposure scenarios are described in Volume II, Appendix F.</p> <p>(b) The lifetime dose is the radiation dose received from intake during the exposure period and up to 50 years after exposure due to radionuclides deposited in the body during the exposure period.</p> <p>(c) LCF = latent cancer fatality.</p> <p>(d) Leachate treatment is a pulse drier operation.</p> <p>(e) If LLW trenches were to be lined, the doses from leachate collection and treatment might be as much as three times the leachate treatment values shown in this table.</p> <p>(f) The value in parentheses is the calculated value based on the population dose and the appropriate health effects conversion factor. The actual number of LCFs must be a whole number (deaths).</p> <p>(g) The population lifetime impacts are based on exposure for the same exposure pathways impacting the resident gardener MEI.</p>						

(a) The annual limit for occupational exposures is 5000 mrem/year (10 CFR 835).

**Table 5.36.** Non-Involved Worker and Public Health Impacts from Routine Atmospheric Releases of Radionuclides – Alternative Group A, Upper Bound Waste Volume

Exposed Group	Exposure Scenario <sup>(a)</sup>	Facility	Lifetime Dose <sup>(b)</sup> (mrem)	Probability of an LCF <sup>(c)</sup>	Maximum Annual Dose	
					Year	mrem
Worker Onsite (non-involved)	Industrial	WRAP	2.2E-03	1E-09	2004	1.9E-04
		Modified T Plant Complex	8.9E-01	5E-07	2006	7.2E-02
		Leachate Treatment <sup>(d, e)</sup>	1.9E-07	1E-13	2026	1.1E-08
MEI Offsite	Resident Gardener	WRAP	2.1E-04	1E-10	2004	1.6E-05
		Modified T Plant Complex	2.3E-03	1E-09	2006	1.7E-04
		Leachate Treatment	8.4E-11	5E-17	2026	4.5E-12
		Total	2.5E-03	1E-09	2006	1.9E-04
			<b>(person-rem)</b>	<b>Number of LCFs<sup>(f)</sup></b>	<b>Year</b>	<b>(person-rem)</b>
Population <sup>(g)</sup>	Population within 80 km (50 mi)	WRAP	1.9E-02	0 (1E-05)	2004	1.1E-03
		Modified T Plant Complex	2.2E-01	0 (1E-04)	2006	1.5E-02
		Leachate Treatment	7.6E-09	0 (5E-12)	2026	3.1E-10
		Total	2.4E-01	0 (1E-04)	2006	1.6E-02
<p>(a) The exposure duration for the industrial scenario is 20 years and for the resident gardener, 30 years. The exposure scenarios are described in Volume II, Appendix F.</p> <p>(b) The lifetime dose is the radiation dose received from intake during the exposure period and up to 50 years after exposure due to radionuclides deposited in the body during the exposure period.</p> <p>(c) LCF = latent cancer fatality.</p> <p>(d) Leachate treatment is a pulse drier operation.</p> <p>(e) If LLW trenches were to be lined, the doses from leachate collection and treatment might be as much as three times the leachate treatment values shown in this table.</p> <p>(f) The value in parentheses is the calculated value based on the population dose and the appropriate health effects conversion factor. The actual number of LCFs must be a whole number (deaths).</p> <p>(g) The population lifetime impacts are based on exposure for the same exposure pathways impacting the resident gardener MEI.</p>						

**Table 5.37.** Non-Involved Worker and Public Health Impacts from Routine Atmospheric Releases of Chemicals – Alternative Group A, All Waste Volumes

Volume	Exposed Group	Exposure Scenario <sup>(a)</sup>	Facility	Risk of Cancer Incidence <sup>(b)</sup>	Peak Annual Hazard Quotient <sup>(c)</sup>
Hanford Only and Lower Bound	Worker Onsite (non-involved)	Industrial	WRAP	1.2E-09	8.9E-05
			Modified T Plant Complex	3.2E-08	2.3E-03
			Total	NA	NA
	MEI Offsite	Resident Gardener	WRAP	5.6E-11	3.4E-06
			Modified T Plant Complex	6.1E-11	7.2E-06
			Total	1.2E-10	1.1E-05
	Population	Population within 80 km (50 mi)	WRAP	0 (5E-06) <sup>(d)</sup>	NA <sup>(e,f)</sup>
			Modified T Plant Complex	0 (6E-06) <sup>(d)</sup>	NA
			Total	0 (1E-05) <sup>(d)</sup>	NA
Upper Bound	Worker Onsite (non-involved)	Industrial	WRAP	5.3E-09	6.9E-04
			Modified T Plant Complex	1.8E-07	2.4E-03
			Total	NA	NA
	MEI Offsite	Resident Gardener	WRAP	2.3E-10	2.5E-05
			Modified T Plant Complex	2.0E-10	2.5E-05
			Total	4.2E-10	5.0E-05
	Population	Population within 80 km (50 mi)	WRAP	0 (2E-05) <sup>(d)</sup>	NA <sup>(e,f)</sup>
			Modified T Plant Complex	0 (2E-05) <sup>(d)</sup>	NA
			Total	0 (4E-05) <sup>(d)</sup>	NA
<p>(a) The exposure duration for the industrial scenario is 20 years and for the resident gardener, 30 years. The exposure scenarios are described in Volume II, Appendix F.</p> <p>(b) The individual risk of cancer incidence is evaluated for the exposure duration defined for the given exposure scenario starting in the year that provides the highest total impact.</p> <p>(c) Hazard quotients are reported for the year of highest exposure.</p> <p>(d) Population risk from cancer is expressed as the inferred number of fatal and non-fatal cancers in the exposed population over the lifetime of the population from intakes during the remediation period. The actual value must be a whole number (cancers).</p> <p>(e) Hazard quotients are designed as a measure of impacts on an individual and are not meaningful for population exposures.</p> <p>(f) NA = not applicable.</p>					

**Table 5.38.** Occupational Radiation Exposure – Alternative Group A, Hanford Only Waste Volume

Facility	Operating Period	Worker Category <sup>(a)</sup>	Workers (FTE) <sup>(b)</sup>	Average Dose Rate (mrem/yr)	Workforce Dose (person-rem)	Workforce LCF <sup>(c)</sup>
LLW and MLLW Trenches	2002–2046	Operator	14	54	34	0 (2E-02)
		RCT	4	45	8.5	0 (5E-03)
		Other	66	35	104	0 (6E-02)
ILAW	2008–2028	Workers	70	300 <sup>(e)</sup>	443	0 (3E-01)
	2032–2046	Workers	20	14	4.1	0 (2E-03)
CWC	2002–2046	Operator	12	54	29	0 (2E-02)
		RCT	4	45	8.6	0 (5E-03)
		Other	55	17	42	0 (3E-02)
WRAP	2002–2032	Operator	13	18	7.3	0 (4E-03)
		RCT	9	36	10	0 (6E-03)
		Other	29	13	12	0 (7E-03)
	2033–2039	Operator	9	18	1.2	0 (7E-04)
		RCT	6	36	1.6	0 (1E-03)
		Other	21	13	1.9	0 (1E-03)
Modified T Plant Complex	2002–2032	Operator	20	9	5.6	0 (3E-03)
		RCT	18	13	7.3	0 (4E-03)
		Other	38	7	8.2	0 (5E-03)
	2033–2046	Operator	14	9	1.7	0 (1E-03)
		RCT	13	13	2.3	0 (1E-03)
		Other	27	7	2.6	0 (2E-03)
	2013–2031	Operator	10	13	2.6	0 (2E-03)
		RCT	10	13	2.4	0 (1E-03)
		Other	20	13	4.9	0 (3E-03)
Generator Staff <sup>(f)</sup>	2002–2019	Operator	15	34	9.2	0 (6E-03)
		RCT	12	35	8	0 (5E-03)
	2020–2026	Operator	5	34	1.2	0 (7E-04)
		RCT	3	35	0.7	0 (4E-04)
	2027–2044	Operator	1	34	0.6	0 (4E-04)
		RCT	1	35	0.6	0 (4E-04)
Pulse Driers	2026–2077	Operator <sup>(d)</sup>	0.4	54	1.1	0 (7E-04)
<b>Total</b>					<b>765</b>	<b>0 (5.0E-01)</b>
<p>(a) RCT = radiation control technician.</p> <p>(b) The number of workers is the average necessary for the facility during the indicated period.</p> <p>(c) LCF = latent cancer fatality. Workforce LCFs are the inferred number of cancer deaths in the exposed workforce, which must be a whole number (deaths). The value in parentheses is the calculated value based on the workforce dose and the appropriate health effects conversion factor.</p> <p>(d) Operators are provided by contract with the vendor operating the pulse drier unit. Radiological monitoring (RCT) resources are included with the RCT resources for LLW/MLLW trenches.</p> <p>(e) The dose rates for placement of ILAW into disposal facilities are higher than for other solid waste management operations because the material emits more radiation.</p> <p>(f) Staff in the solid waste support services group that work as needed in various solid waste facilities.</p>						



**Table 5.39.** Occupational Radiation Exposure – Alternative Group A, Lower Bound Waste Volume

Facility	Operating Period	Worker Category <sup>(a)</sup>	Workers (FTE) <sup>(b)</sup>	Average Dose Rate (mrem/yr)	Workforce Dose (person-rem)	Workforce LCF <sup>(c)</sup>
LLW and MLLW Trenches	2002–2046	Operator	14	54	34	0 (2E-02)
		RCT	4	45	8.5	0 (5E-03)
		Other	66	35	104	0 (6E-02)
ILAW	2008–2028	Workers	70	300 <sup>(e)</sup>	443	0 (3E-01)
	2032–2046	Workers	20	14	4.1	0 (2E-03)
CWC	2002–2046	Operator	12	54	29	0 (2E-02)
		RCT	4	45	8.6	0 (5E-03)
		Other	55	17	42	0 (3E-02)
WRAP	2002–2032	Operator	13	18	7.3	0 (4E-03)
		RCT	9	36	10	0 (6E-03)
		Other	29	13	12	0 (7E-03)
	2033–2039	Operator	9	18	1.2	0 (7E-04)
		RCT	6	36	1.6	0 (1E-03)
		Other	21	13	1.9	0 (1E-03)
Modified T Plant Complex	2002–2032	Operator	20	9	5.6	0 (3E-03)
		RCT	18	13	7.3	0 (4E-03)
		Other	38	7	8.2	0 (5E-03)
	2033–2046	Operator	14	9	1.7	0 (1E-03)
		RCT	13	13	2.3	0 (1E-03)
		Other	27	7	2.6	0 (2E-03)
	2013–2031	Operator	10	13	2.6	0 (2E-03)
		RCT	10	13	2.4	0 (1E-03)
		Other	20	13	4.9	0 (3E-03)
Generator Staff <sup>(f)</sup>	2002–2019	Operator	15	34	9.2	0 (6E-03)
		RCT	12	35	8	0 (5E-03)
	2020–2026	Operator	5	34	1.2	0 (7E-04)
		RCT	3	35	0.7	0 (4E-04)
	2027–2044	Operator	1	34	0.6	0 (4E-04)
		RCT	1	35	0.6	0 (4E-04)
Pulse Driers	2026–2077	Operator <sup>(d)</sup>	0.8	54	2.2	0 (9E-04)
<b>Total</b>					<b>766</b>	<b>0 (5.0E-01)</b>
<p>(a) RCT = radiation control technician.</p> <p>(b) The number of workers is the average necessary for the facility during the indicated period.</p> <p>(c) LCF = latent cancer fatality. Workforce LCFs are the inferred number of cancer deaths in the exposed workforce, which must be a whole number (deaths). The value in parentheses is the calculated value based on the workforce dose and the appropriate health effects conversion factor.</p> <p>(d) Operators are provided by contract with the vendor operating the pulse drier unit. Radiological monitoring (RCT) resources are included with the RCT resources for LLW/MLLW trenches.</p> <p>(e) The dose rates for placement of ILAW into disposal facilities are higher than for other solid waste management operations because the material emits more radiation.</p> <p>(f) Staff in the solid waste support services group that work as needed in various solid waste facilities.</p>						

**Table 5.40.** Occupational Radiation Exposure – Alternative Group A, Upper Bound Waste Volume

Facility	Operating Period	Worker Category <sup>(a)</sup>	Workers (FTE) <sup>(b)</sup>	Average Dose Rate (mrem/yr)	Workforce Dose (Person-rem)	Workforce LCF <sup>(c)</sup>
LLW and MLLW Trenches	2002–2046	Operator	14	54	34	0 (2E-02)
		RCT	4	45	8.5	0 (5E-03)
		Other	66	35	104	0 (6E-02)
ILAW	2008–2028	Workers	70	300 <sup>(e)</sup>	443	0 (3E-01)
	2032–2046	Workers	20	14	4.1	0 (2E-03)
CWC	2002–2046	Operator	12	54	29	0 (2E-02)
		RCT	4	45	8.6	0 (5E-03)
		Other	55	17	42	0 (3E-02)
WRAP	2002–2032	Operator	13	18	7.3	0 (4E-03)
		RCT	9	36	10	0 (6E-03)
		Other	29	13	12	0 (7E-03)
	2033–2039	Operator	9	18	1.2	0 (7E-04)
		RCT	6	36	1.6	0 (1E-03)
		Other	32	13	1.9	0 (1E-03)
Modified T Plant Complex	2002–2032	Operator	20	9	5.5	0 (3E-03)
		RCT	18	13	7.4	0 (4E-03)
		Other	38	7	8.2	0 (5E-03)
	2033–2046	Operator	14	9	1.7	0 (1E-03)
		RCT	13	13	2.3	0 (1E-03)
		Other	27	7	2.6	0 (2E-03)
	2013–2031	Operator	10	13	2.6	0 (2E-03)
		RCT	10	13	2.4	0 (1E-03)
		Other	20	13	4.9	0 (3E-03)
Generator Staff <sup>(f)</sup>	2002–2019	Operator	20	34	12	0 (7E-03)
		RCT	13	35	8.2	0 (5E-03)
	2020–2026	Operator	7	34	1.7	0 (1E-03)
		RCT	5	35	1.2	0 (7E-04)
	2027–2044	Operator	3	34	1.8	0 (1E-03)
		RCT	2	35	1.3	0 (8E-04)
Pulse Driers	2026–2077	Operator <sup>(d)</sup>	1.2	54	3.3	0 (2E-03)
<b>Total</b>					<b>774</b>	<b>0 (5.0E-01)</b>
<p>(a) RCT = radiation control technician.</p> <p>(b) The number of workers is the average necessary for the facility during the indicated period.</p> <p>(c) LCF = latent cancer fatality. Workforce LCFs are the inferred number of cancer deaths in the exposed workforce, which must be a whole number (deaths). The value in parentheses is the calculated value based on the workforce dose and the appropriate health effects conversion factor.</p> <p>(d) Operators are provided by contract with the vendor operating the pulse drier unit. Radiological monitoring (RCT) resources are included with the RCT resources for LLW/MLLW trenches.</p> <p>(e) The dose rates for placement of ILAW into disposal facilities are higher than for other solid waste management operations because the material emits more radiation.</p> <p>(f) Staff in the solid waste support services group that work as needed in various solid waste facilities.</p>						

### 5.11.1.1.3 Accidents

The impacts of accidents involving radiological and chemical contaminants and industrial accidents are evaluated in this section. The impacts of these accidents are expected to bound impacts of events that could be initiated by malevolent intent. Waste management operations would involve a continuing potential for industrial accidents and accidental release of contaminants in four Hanford facilities: the Central Waste Complex (CWC) for waste storage, the WRAP for waste treatment, the T Plant Complex (or similar new waste processing facility) for waste treatment, and the HSW disposal facilities for waste disposal. Accident information for each of these facilities is presented in the sections that follow. Additional information on radiological and chemical accidents is provided in Volume II, Appendix F, Section F.2 (including adjustment methods used to derive radiological consequence data).

Non-radiological consequences were evaluated by comparing estimated air concentrations with the TEEL or ERPG for a given chemical. Additional information, including definitions of ERPG/TEEL levels, is presented in Volume II, Appendix F.

Human health and safety impacts to workers actually involved in accidents (involved workers) are addressed in the general sense and not for each particular facility or potential accident for any of the alternative groups because the potential consequences would be highly variable, ranging from no effect to a fatality for one or more workers. The most likely consequence for any involved worker would be no or small impact. Workers involved in an accident could receive physical injuries or be killed during an accident, receive a range of radiation doses (none likely to be fatal), or be exposed to a range of hazardous chemical concentrations that could be high but of relatively short duration and, again, thought unlikely to be fatal. The reason for an optimistic outlook on radiation dose or chemical exposure for the involved worker under accident conditions is that in situations where there is a potential for radioactive or chemical risks, additional precautions are taken and workers are typically accompanied by a health physics technician.

The greatest likelihood of worker fatalities would be from physical trauma received during an accident. For example, the drum explosion and ion exchange module explosion accidents could result in involved worker fatalities if the workers were in the explosion blast zone. Most accidents would involve only one or two workers; the exception would be low probability, beyond-design-basis seismic events where a number of involved workers could be affected. Depending on the type of facility, worker location, and time of accident, zero to perhaps a dozen worker fatalities could result. Burial ground workers would probably be the least affected by extensive seismic structural damage for the types of facilities considered. Similarly, CWC workers would be more likely to avoid obstacles and debris and exit the facilities since there are no massive storage structures in this area. Workers in other waste management facilities could be more affected by falling debris as a result of extensive seismic damage.

Anticipated health impacts to all workers from industrial accidents during construction and operations would be 620 to 640 total recordable cases, 260 lost workday cases, and 8900 to 9200 lost workdays. A total of about 20,600 to 21,200 worker-years would be required to complete all activities over the operational period. Of that total, about 2800 to 3400 worker-years are for site support and waste

generator services that do not appear in the direct facility worker and impact estimates in the following sections. About 97 to 99 percent of these health impacts are from operations.

### 5.11.1.1.3.1 Storage – CWC

No new storage would be needed at the CWC under Alternative Group A; therefore, no new construction would be required. Operations would continue at existing levels during the near-term, possibly increasing then declining as completion of waste processing is approached.

**Radiological consequences.** Six accident scenarios involving radioactive material at the CWC were evaluated as part of the Interim Safety Basis (Vail 2001a). These accidents were a handling/forklift-caused drum failure, a drum-handling fire, a flammable gas explosion, a truck impact and fire, a design-basis earthquake, and a beyond-design-basis earthquake. They were selected for analysis using a hazard identification and assessment process and have estimated annual frequencies of occurrence ranging from 0.11 per year to 4.0E-06 per year, categorized as Anticipated and Extremely Unlikely, respectively. Accident consequences shown in terms of radiation dose and potential LCFs are presented in Table 5.41.

The largest consequences to the offsite MEI would be from a beyond-design-basis earthquake. This MEI would receive a dose of about 13 rem and have an 8E-03 probability of an LCF. This accident would also result in the largest consequences to the population. About 30 LCFs would be expected. LCFs in the population would be expected for all analyzed accidents except a handling/forklift drum failure.

**Table 5.41.** Radiological Consequences of Accidents at the CWC

Accident	Estimated Annual Frequency	Offsite MEI		Offsite Population		Non-Involved Worker	
		Dose (rem)	Prob. LCF <sup>(a)</sup>	Dose (person-rem)	Number of LCFs <sup>(b)</sup>	Dose (rem)	Prob. LCF <sup>(a)</sup>
Handling/Forklift Drum Failure	1.1E-01	0.0026	2E-06	11.5	0 (7E-03)	1.2	0.0007
Drum-Handling Fire	1.1E-04	0.7	4E-04	3000	2	310	0.2
Flammable Gas Explosion	4.2E-04	1.0	6E-04	4300	3	460	0.3
Truck Impact and Fire	4.0E-06	11.0	6E-03	47,000	30	4900	<sup>(d)</sup>
Design-Basis Earthquake	3.3E-03	1.1	6E-04	4700	3	480	0.3
Beyond-Design-Basis Earthquake	<sup>(c)</sup>	13	8E-03	56,000	30	5900	<sup>(d)</sup>

(a) Prob. LCF = the probability of a latent cancer fatality in the hypothetically exposed individual.  
 (b) Number LCFs = the number of latent cancer fatalities in the hypothetically exposed population. Value indicated in parentheses if less than one fatality estimated.  
 (c) Not quantified in reference but frequency less than design-basis earthquake.  
 (d) This accident would likely result in a fatality.

The largest consequences to a non-involved worker would be from the truck impact and fire and the beyond-design-basis earthquake accidents. The non-involved worker would receive a dose of about 4900 rem and 5900 rem, respectively. Both of these doses would likely result in a fatality.

**Non-radiological (chemical) consequences.** Given that MLLW is also stored in the CWC, non-radioactive hazardous materials may be involved in the same accident scenarios as radioactive materials. The radiological accident analysis determined that two accidents having the largest consequences are the flammable gas explosion and the truck impact and fire accidents. Potential non-radiological consequences of these two accident scenarios were assumed in the safety analysis (Vail 2001a) to provide a reasonable upper limit for all accidents. Accident consequences are presented in Table 5.42, which shows the ratio of estimated concentrations to TEEL values. A value less than 1 indicates an acceptable condition. A blank ratio in the table indicates a more restrictive TEEL level was previously met (for example, the ratio was less than 1) and evaluation of higher TEEL-level ratios is unnecessary.

The air concentration at the location of the offsite MEI would be well below the TEEL/ERPG-1 level for all chemicals except beryllium. The air concentration at the location of the MEI would exceed the TEEL/ERPG-1 level beryllium because of the truck impact and fire accident. A hypothetically exposed individual would not be expected to experience or develop irreversible or other serious health effects or symptoms that might impair his or her ability to take protective action. No impacts would be expected.

For the onsite non-involved worker, the TEEL/ERPG-3 level might be exceeded for beryllium for both of these accidents. This individual might experience or develop a life-threatening effect. TEEL/ERPG-2 levels might also be exceeded for mercury, lead, potassium hydroxide, phosphoric acid, and sodium hydroxide. An individual might experience or develop irreversible or other serious health effects or symptoms that might impair his or her ability to take protective action. The TEEL/ERPG-1 levels might also be exceeded for cadmium, nitric acid, and hydrofluoric acid.

Like the radiological consequences to involved workers, non-radiological consequences could be highly variable—ranging from no exposure to high concentrations of chemicals—depending upon whether or not a worker were directly in the plume of immediately released material, and for how long.

**Industrial accidents – construction.** No new construction would take place at the CWC under Alternative Group A, and no industrial accidents from construction would occur.

**Industrial accidents – operations.** Direct operations staffing in the CWC would total 3200 worker-years. Estimated health and safety impacts would be 85 total recordable cases, 36 lost workday cases, and 1200 lost workdays.

**Table 5.42. Non-Radiological Air Concentrations for Accidents at the CWC**

Chemical	Onsite Worker Conc. (mg/m <sup>3</sup> )	Offsite MEI Conc. (mg/m <sup>3</sup> )	TEEL-1 (mg/m <sup>3</sup> )	TEEL-2 (mg/m <sup>3</sup> )	TEEL-3 (mg/m <sup>3</sup> )	Onsite <sup>(a)</sup> TEEL-1 Ratio	Onsite TEEL-2 Ratio	Onsite TEEL-3 Ratio	Offsite <sup>(b)</sup> TEEL-1 Ratio	Offsite TEEL-2 Ratio	Offsite TEEL-3 Ratio
<b>Drum Explosion</b>											
Ammonium fluoride	1.0E+00	2.3E-03	2.5	2.5	40	4.2E-01	(c)	(c)	9.3E-04	(c)	(c)
Ammonium nitrate	1.0E+00	2.3E-03	10	10	500	1.0E-01	(c)	(c)	2.3E-04	(c)	(c)
Ammonium sulfate	2.1E+00	4.5E-03	125	500	500	1.7E-02	(c)	(c)	3.6E-05	(c)	(c)
Beryllium	7.7E-01	1.6E-03	0.005	0.025	0.1	1.5E+02	3.1E+01	7.7E+00	3.3E-01	(c)	(c)
Carbon tetrachloride	4.9E+00	1.1E-02	125	600	4000	4.0E-02	8.2E-03	(c)	8.5E-05	(c)	(c)
Hydrofluoric acid	7.0E+00	1.5E-02	1.5	15	40	4.7E+00	4.7E-01	(c)	1.0E-02	(c)	(c)
Nitric acid	8.2E+00	1.7E-02	2.5	12.5	50	3.3E+00	6.5E-01	(c)	7.0E-03	(c)	(c)
Phosphoric acid	7.0E+00	1.5E-02	3	5	500	2.3E+00	1.4E+00	1.4E-02	5.2E-03	(c)	(c)
Potassium hydroxide	7.5E+00	1.6E-02	2	2	150	3.8E+00	3.8E+00	5.0E-02	8.2E-03	(c)	(c)
Sodium hydroxide	1.0E+01	2.1E-01	0.5	5	50	2.1E+01	2.1E+00	2.1E-01	4.3E-01	(c)	(c)
Sulfuric acid	4.4E-01	9.7E-04	2	10	30	2.2E-01	(c)	(c)	4.8E-04	(c)	(c)
<b>Truck Impact and Fire</b>											
Ammonium fluoride	3.5E-01	7.4E-04	2.5	2.5	40	1.4E-01	(c)	(c)	3.0E-04	(c)	(c)
Ammonium nitrate	3.5E-01	7.4E-04	10	10	500	3.5E-02	(c)	(c)	7.4E-05	(c)	(c)
Ammonium sulfate	6.8E-01	1.4E-03	125	500	500	5.4E-03	(c)	(c)	1.2E-05	(c)	(c)
Beryllium	6.0E+00	1.4E-02	0.005	0.025	0.1	1.2E+03	2.4E+02	6.0E+01	2.7E+00	5.4E-01	(c)
Carbon tetrachloride	1.6E+00	3.5E-03	125	600	4000	1.2E-02	(c)	(c)	2.8E-05	(c)	(c)
Hydrofluoric acid	2.3E+00	4.9E-03	1.5	15	40	1.5E+00	1.5E-01	(c)	2.5E-03	(c)	(c)
Nitric acid	1.0E+01	2.1E-02	2.5	12.5	50	4.2E+00	8.3E-01	(c)	8.5E-03	(c)	(c)
Phosphoric acid	2.3E+00	4.9E-03	3	5	500	7.5E-01	(c)	(c)	1.6E-03	(c)	(c)
Potassium hydroxide	2.4E+00	5.3E-03	2	2	150	1.2E+00	1.2E+00	1.6E-02	2.7E-03	(c)	(c)
Sodium hydroxide	1.4E+01	3.0E-02	0.5	5	50	2.8E+01	2.8E+00	2.8E-01	6.0E-02	(c)	(c)
Sulfuric acid	1.4E-01	3.1E-04	2	10	30	6.9E-02	(c)	(c)	1.5E-04	(c)	(c)
Mercury	1.7E+00	3.8E-03	0.025	0.1	10	6.9E+01	1.7E+01	1.7E-01	3.8E-02	(c)	(c)
Cadmium	1.7E+00	3.8E-03	0.03	4	9	5.8E+01	4.3E-01	(c)	1.3E-01	(c)	(c)
Polychlorinated biphenyls (PCBs)	3.5E-01	7.5E-04	3	5	5	1.2E-01	6.9E-02	(c)	2.5E-04	(c)	(c)
Lead	1.7E+00	3.8E-03	0.15	0.25	100	1.2E+01	6.9E+00	1.7E-02	2.5E-02	(c)	(c)
(a) Onsite = non-involved worker.											
(b) Offsite = offsite MEI.											
(c) Ratio not presented because a more restrictive TEEL level was previously met and evaluation of higher TEEL-level ratio is unnecessary.											

### 5.11.1.1.3.2 Treatment – Waste Receiving and Processing Facility

**Radiological consequences.** Seven accident scenarios involving radioactive material at the WRAP were evaluated in the WRAP Final Safety Analysis Report (Tomaszewski 2001). These accident scenarios were a handling/forklift drum failure, a drum-handling fire, a container-handling explosion, a fire in a process enclosure (glovebox), an explosion in process enclosure (glovebox), design-basis earthquake, and beyond-design-basis earthquake. These accidents were selected for analysis through a hazard identification and assessment process. Estimated annual frequencies of occurrence are described qualitatively and quantitatively. The frequencies of occurrence range from anticipated (with an associated annual frequency range of 1 to 0.01) to a much lower frequency for the beyond-design-basis earthquake. Accident consequences, shown in terms of radiation dose and potential LCF, are presented in Table 5.43.

The largest consequences to the MEI would be from a beyond-design-basis earthquake. The MEI would receive a dose of about 1.1 rem and have a 7E-04 probability of an LCF. Six of the seven accidents examined would result in one to three LCFs in the population.

The largest consequences to a non-involved worker would be from a beyond-design-basis earthquake. The non-involved worker would receive a dose of about 500 rem and have a 0.3 probability of an LCF.

**Table 5.43.** Radiological Consequences of Accidents at WRAP

Accident	Estimated Annual Frequency	Offsite MEI		Offsite Population		Non-Involved Worker	
		Dose (rem)	Prob. LCF <sup>(a)</sup>	Dose (person-rem)	Number LCFs <sup>(b)</sup>	Dose (rem)	Prob. LCF <sup>(a)</sup>
Handling/Forklift Drum Failure	Anticipated <sup>(c)</sup>	0.0014	8E-07	6.0	0 (0.003)	0.6	3E-04
Drum-Handling Fire	2.0E-03	0.31	2E-04	1400	1 (0.8)	140	9E-02
Container-Handling Explosion	3.0E-03	0.74	5E-04	3300	2	340	2E-01
Process Enclosure Fire	2.0E-03	0.20	1E-04	900	1 (0.5)	100	6E-02
Process Enclosure Explosion	3.0E-03	0.67	4E-04	2900	2	300	2E-01
Design-Basis Earthquake	1.0E-03	0.92	6E-04	4100	2	420	3E-01
Beyond-Design-Basis Earthquake	<sup>(d)</sup>	1.1	7E-04	4800	3	500	3E-01

(a) Prob. LCF = the probability of a latent cancer fatality in the hypothetically exposed individual.  
(b) Number LCFs = the number of latent cancer fatalities in the hypothetically exposed population. Value indicated in parentheses if less than one fatality estimated.  
(c) Anticipated accidents are estimated to occur with a frequency ranging from 0.01 to 1.0 per year.  
(d) Frequency was not specified in the source document.

**Non-radiological (chemical) consequences.** Because MLLW would also be handled at the WRAP, non-radioactive hazardous materials may be involved in accidents. A process enclosure fire was evaluated for non-radiological consequences. The accident scenario for this analysis is the same as evaluated for radiological consequences of the process enclosure fire, where containers rupture and burn. A fire in the process enclosure is postulated due to the mixing of incompatible materials or damage to the packaging of pyrophoric material that allows ignition to take place. Because no mitigation credit is taken for the process enclosure, the consequence of this event is greater than any container fire at the WRAP. Other potential accidents would be associated with consequences that are similar to, or lower than, those from this event. Accident consequences are presented in Table 5.44.

The air concentration at the location of the offsite MEI could exceed the TEEL/ERPG-1 level for beryllium, cadmium, and mercury. Hypothetically exposed individuals would not be expected to experience or develop irreversible or other serious health effects or symptoms that might impair their ability to take protective action.

For the onsite, non-involved worker, the TEEL/ERPG-3 level might be exceeded for beryllium, cadmium, mercury, and sodium oxide. This hypothetically exposed individual might experience or develop a life-threatening effect. The TEEL/ERPG-2 level could also be exceeded for uranyl nitrate hexahydrate, nitric acid, phosphoric acid, sodium, sodium hydroxide, and naphthylamine tritium. At the TEEL/ERPG-2 level, an individual might experience or develop irreversible or other serious health effects or symptoms that might impair his or her ability to take protective action. No other chemical would exceed the TEEL/ERPG-1 levels; therefore, no serious health effects or symptoms would be expected.

Like the radiological consequences to involved workers, non-radiological consequences could be highly variable—ranging from no exposure to high concentrations of chemicals—depending upon whether or not a worker were directly in the plume of immediately released material, and for how long.

**Industrial accidents.** Direct operations staffing in the WRAP would total 1800 worker-years. Estimated health and safety impacts would be 48 total recordable cases, 20 lost workday cases, and 710 lost workdays.



**Table 5.44. Non-Radiological Air Concentrations for a Process Enclosure Fire Accident at WRAP**

Chemical	Onsite Worker Conc. (mg/m <sup>3</sup> )	Offsite MEI Conc. (mg/m <sup>3</sup> )	TEEL-1 (mg/m <sup>3</sup> )	TEEL-2 (mg/m <sup>3</sup> )	TEEL-3 (mg/m <sup>3</sup> )	Onsite <sup>(a)</sup> TEEL-1 Ratio	Onsite TEEL-2 Ratio	Onsite TEEL-3 Ratio	Offsite <sup>(b)</sup> TEEL-1 Ratio	Offsite TEEL-2 Ratio	Offsite TEEL-3 Ratio
Ammonia	3.9E-01	8.5E-04	15	100	500	2.6E-02	(c)	(c)	5.7E-05	(c)	(c)
Ammonium nitrate	6.9E+00	1.5E-02	10	10	500	6.9E-01	(c)	(c)	1.5E-03	(c)	(c)
Beryllium	6.1E+00	1.3E-02	0.005	0.025	0.1	1.2E+03	2.4E+02	6.1E+01	2.7E+00	5.3E-01	(c)
Butyl alcohol	7.0E-01	1.5E-03	150	150	4000	4.7E-03	(c)	(c)	1.0E-05	(c)	(c)
Cadmium	7.8E+01	1.7E-01	0.03	4	9	2.6E+03	2.0E+01	8.7E+00	5.7E+00	4.3E-02	(c)
Carbon tetrachloride	1.3E+01	2.9E-02	125	600	4000	1.1E-01	(c)	(c)	2.3E-04	(c)	(c)
Cyclohexane	3.3E+00	7.1E-03	3000	4000	4000	1.1E-03	(c)	(c)	2.4E-06	(c)	(c)
Dichloroethane	1.0E+00	2.2E-03	7.5	200	200	1.4E-01	(c)	(c)	2.9E-04	(c)	(c)
Dioxane	2.2E+01	4.8E-02	75	350	1500	2.9E-01	(c)	(c)	6.3E-04	(c)	(c)
Ethyl acetate (acetic ether)	7.8E-01	1.7E-03	1500	1500	7500	5.2E-04	(c)	(c)	1.1E-06	(c)	(c)
Hydrogen peroxide	4.4E-01	9.5E-04	12.5	60	125	3.5E-02	(c)	(c)	7.6E-05	(c)	(c)
Indole-2-C-14 picrate	8.6E-05	1.9E-07	0.3	0.5	10	2.9E-04	(c)	(c)	6.2E-07	(c)	(c)
Manganese	5.2E-02	1.1E-04	3	5	500	1.7E-02	(c)	(c)	3.8E-05	(c)	(c)
Mercury	3.8E+01	8.3E-02	0.025	0.1	10	1.5E+03	3.8E+02	3.8E+00	3.3E+00	(c)	(c)
Methanol	1.1E+00	2.4E-03	250	1250	6000	4.4E-03	(c)	(c)	9.5E-06	(c)	(c)
Naphthylamine tritium	8.6E+01	1.9E-01	7.5	50	300	1.1E+01	1.7E+00	2.9E-01	2.5E-02	(c)	(c)
Nitric acid	3.0E+01	6.6E-02	2.5	12.5	50	1.2E+01	2.4E+00	6.1E-01	2.7E-02	(c)	(c)
Phosphoric acid	4.4E+01	9.5E-02	3	5	500	1.5E+01	8.7E+00	8.7E-02	3.2E-02	(c)	(c)
Propane	7.8E-01	1.7E-03	3500	3500	3500	2.2E-04	(c)	(c)	4.9E-07	(c)	(c)
Sodium	2.3E+00	4.9E-03	2	2	10	1.1E+00	(c)	(c)	2.5E-03	(c)	(c)
Sodium hydroxide	3.2E+01	7.0E-02	0.5	5	50	6.4E+01	6.4E+00	6.4E-01	1.4E-01	(c)	(c)
Sodium hypochlorite	6.5E-03	1.4E-05	75	500	500	8.6E-05	(c)	(c)	1.9E-07	(c)	(c)
Sodium oxide	4.1E+01	9.0E-02	10	10	10	4.1E+00	4.1E+00	4.1E+00	9.0E-03	(c)	(c)
Styrene	2.4E+00	5.3E-03	200	1000	4000	1.2E-02	(c)	(c)	2.6E-05	(c)	(c)
Tetrahydrofuran	1.2E+00	2.7E-03	750	3000	6000	1.7E-03	(c)	(c)	3.6E-06	(c)	(c)
Tetralin	8.6E-05	1.9E-07	NA	NA	NA	NA	NA	NA	NA	NA	NA
Toluene	7.6E-01	1.6E-03	150	1000	3500	5.0E-03	(c)	(c)	1.1E-05	(c)	(c)
Uranyl nitrate hexahydrate	5.3E+00	1.2E-02	0.6	0.6	10	8.8E+00	8.8E+00	5.3E-01	1.9E-02	(c)	(c)
Vinyl acetate	2.4E+00	5.3E-03	150	250	1500	1.6E-02	(c)	(c)	3.5E-05	(c)	(c)
Vinyl chloride	3.6E+00	7.8E-03	12.5	12.5	200	2.9E-01	(c)	(c)	6.3E-04	(c)	(c)
Zirconium	7.5E-01	1.6E-03	10	10	50	7.5E-02	(c)	(c)	1.6E-04	(c)	(c)

(a) Onsite = non-involved worker.  
(b) Offsite = offsite MEI.  
(c) Ratio not presented because a more restrictive TEEL level was previously met and evaluation of a higher TEEL-level ratio is unnecessary.  
NA = not applicable.

### 5.11.1.1.3.3 Treatment – Modified T Plant Complex

**Radiological consequences – continuing T Plant activities.** Six accident scenarios involving current activities and radioactive material at T Plant were evaluated as part of the Interim Safety Basis (Bushore 1999, 2001). These accidents were a spray release in the 221-T canyon, a railcar spill in the 221-T rail tunnel, a filter fire in the 2706-T facility, a LLW drum storage fire in the 214-T building, a filter bank fire in the 219-T building, and a seismic event.

These accidents were selected for analysis through a hazard identification and assessment process. Estimated annual frequencies of occurrence are described qualitatively and quantitatively. The frequencies of occurrence range from less than 1.E-02 to 1.9.E-05 for the 291-T filter bank fire, categorized as unlikely and extremely unlikely, respectively (see Volume II, Appendix F, Section F.2.2). Accident consequences, shown in terms of radiation dose and potential LCF, are presented in Table 5.45.

The largest consequences to the MEI would be from an outdoor drum-handling accident with fire at the 2706-T facility. The MEI would receive a dose of about 0.70 rem and have a 4E-04 probability of an LCF. Within the population, this accident would result in three LCFs, and three of the other accidents examined would result in one LCF.

The largest consequences to a non-involved worker would also be from an outdoor drum-handling accident with fire at the 2706-T facility. The non-involved worker would receive a dose of about 500 rem and have a 3E-01 probability of an LCF.

**Table 5.45.** Radiological Consequences of Accidents at the Modified T Plant Complex for Continuing T Plant Activities

Accident	Estimated Annual Frequency	Offsite MEI		Offsite Population		Non-Involved Worker	
		Dose (rem)	Prob. LCF <sup>(a)</sup>	Dose (person-rem)	Number LCFs <sup>(b)</sup>	Dose (rem)	Prob. LCF <sup>(a)</sup>
Spray Release, 221-T Canyon	2.0E-05	0.31	2E-04	2100	1	220	1E-01
Railcar Spill, 221-T Rail Tunnel	< 0.01 <sup>(c)</sup>	0.10	6E-05	650	0 (0.4)	68	4E-02
2706-T Outdoor Drum Fire	1.0E-03 to 2.5E-04 <sup>(c)</sup>	0.70	4E-04	4800	3	500	3E-01
214-T LLW Drum Storage Fire	< 0.01 <sup>(c)</sup>	0.15	9E-05	1000	1 (0.6)	110	7E-02
291-T Filter Bank Fire	1.9E-05	0.02	1E-05	140	0 (0.08)	15	9E-03
Seismic Event	<sup>(c, d)</sup>	0.27	2E-04	1900	1	190	1E-01

(a) Prob. LCF = the probably of a latent cancer fatality in the hypothetically exposed individual.  
 (b) Number LCFs = the number of latent cancer fatalities in the hypothetically exposed population. Value indicated in parentheses if less than one fatality estimated.  
 (c) These less quantitative frequencies are also from Bushore (2001).  
 (d) For a design-basis earthquake, the annual frequency would be about  $1 \times 10^{-3}$  or less. In the source document (Bushore 2001), the consequences of this event were compared to evaluation guidelines for an “extremely unlikely” accident, which would correspond to a frequency ranging from  $1 \times 10^{-6}$  to  $1 \times 10^{-4}$  per year.

**Radiological consequences – New Waste Processing Facility.** Four accidents for the proposed new waste processing facility in the modified T Plant Complex were evaluated, based upon the analysis and results of the preliminary safety evaluation for the WRAP Module 2 (WHC 1991). These accidents were a filtered box drop, an unfiltered box drop, a design-basis earthquake with fire, and a tank farm pump spill. These accidents were selected for analysis through a hazard identification and assessment process. Estimated annual frequencies of occurrence range from anticipated (with an annual frequency range of 1 to 0.01) to an extremely unlikely accident (with an annual frequency range of 1.0E-04 to 1.0E-06). Accident consequences, shown in terms of radiation dose and potential LCFs, are presented in Table 5.46.

The largest consequences to the MEI would be from a design-basis earthquake and fire. The MEI would receive a dose of about 0.31 rem and have a 2E-04 probability of an LCF. This accident also results in the largest consequences to the population, but no LCFs would be expected.

The largest consequences to a non-involved worker would also be from a design-basis earthquake and fire. The non-involved worker would receive a dose of about 77 rem and have a 5E-02 probability of an LCF.

Radiological consequences to involved workers from these accidents could be highly variable depending upon whether or not a worker was directly in the plume of immediately released material.

**Non-radiological (chemical) consequences – continuing T Plant activities.** The Interim Safety Basis (Bushore 2001) does not contain an analysis of the potential consequences of accidents involving non-radiological constituents of waste streams. The non-radiological consequences of accidents at WRAP, presented previously (Section 5.11.1.1.3.2), are assumed to represent potential non-radiological consequences of continuing T Plant activities.

**Table 5.46.** Radiological Consequences of Accidents for the Modified T Plant Complex with the New Waste Processing Facility

Accident	Estimated Annual Frequency	Offsite MEI		Offsite Population		Non-Involved Worker	
		Dose (rem)	Prob. LCF <sup>(a)</sup>	Dose (person-rem)	Number LCFs <sup>(b)</sup>	Dose (rem)	Prob. LCF <sup>(a)</sup>
Box Drop (filtered)	1.0E-02	8.9E-05	5E-08	0.21	0 (1E-04)	2.2E-02	1E-05
Box Drop (unfiltered)	1.0E-02	1.8E-01	1E-04	430	0 (0.3)	4.5E+01	3E-02
Design-Basis Earthquake and Fire (unfiltered)	1.0E-04	3.1E-01	2E-04	740	0 (0.4)	7.7E+01	5E-02
Tank Farm Pump Spill	7.7E-04	2.6E-09	2E-12	6.3E-06	0 (4E-09)	6.5E-07	4E-10

(a) Prob. LCF = the probability of a latent cancer fatality in the hypothetically exposed individual.  
(b) Number LCFs = the number of latent cancer fatalities in the hypothetically exposed population. Value indicated in parentheses if less than one fatality estimated.

**Non-radiological (chemical) consequences – New Waste Processing Facility.** Non-radiological consequences for the new waste processing facility have not been evaluated in detail. However, potential non-radiological impacts from accidents in the WRAP are assumed to be representative for potential impacts from new waste processing facility activities. Potential impacts from accidents in the CWC and Low Level Burial Grounds (LLBGs) would likely be bounding for accidents in the modified T Plant Complex.

**Industrial accidents – construction.** Employment for the T Plant Complex modification would total 120 worker-years. Estimated health and safety impacts would be 10 total recordable cases, 3 lost workday cases, and 66 lost workdays.

**Industrial accidents – operations.** Direct operations staffing in the modified T Plant Complex would total 3,900 worker-years. Estimated health and safety impacts would be 100 total recordable cases, 42 lost workday cases, and 1,500 lost workdays.

#### **5.11.1.1.3.4 Disposal – LLBGs**

Disposal and storage of solid radioactive waste generated at the Hanford Site would continue in the HSW disposal facilities of the 200 West and 200 East Areas. Accidents involving the LLW and MLLW trenches were evaluated in the Solid Waste Burial Grounds Interim Safety Basis by Vail (2001c) and the Solid Waste Burial Grounds Interim Safety Analysis by Vail (2001b).

**Radiological consequences – LLW trenches.** The radiological consequences associated with the disposal of LLW (Cat 1, Cat 3, and GTC3) are addressed in this section. Non-radiological (chemical) consequences were not evaluated due to the nature of the waste.

Five credible accidents at the trenches were evaluated as part of the Interim Safety Basis (Vail 2001c) and the Interim Safety Analysis (Vail 2001b). They were a heavy equipment accident with fire, a heavy equipment accident without fire, a drum explosion, an explosion involving an ion-exchange module, and a seismic event. Two other accidents involving high-integrity containers (HICs)—a heavy equipment accident with fire and a seismic event—were also addressed.

These accidents were selected for analysis through a hazard identification and assessment process and have estimated annual frequencies of occurrence ranging from 4.0E-02 per year to 5.3E-04 per year, categorized as anticipated and unlikely, respectively. Accident consequences, shown in terms of both radiation dose and LCFs, are presented in Table 5.47.

The largest consequences to the MEI would be from a heavy equipment accident with fire involving the high integrity containers (HICs). The MEI would receive a dose of about 0.39 rem and have a 2E-04 probability of a LCF. This accident also results in the largest consequences to the population, with one LCF.

**Table 5.47.** Radiological Consequences of Accidents at the Low-Level Waste Trenches

Accident	Estimated Annual Frequency	Offsite MEI		Offsite Population		Non-Involved Worker	
		Dose (rem)	Prob. LCF <sup>(a)</sup>	Dose (person -rem)	Number LCFs <sup>(b)</sup>	Dose (rem)	Prob. LCF <sup>(a)</sup>
Heavy Equipment Accident with Fire	5.3E-04	0.027	2E-05	140	0 (0.08)	14	8E-03
Heavy Equipment Accident without Fire	1.3E-02	0.0022	1E-06	11	0 (0.007)	1	7E-04
Drum Explosion	4.0E-02	0.049	3E-05	250	0 (0.2)	26	2E-02
Explosion in Ion-Exchange Module	1.0E-02	0.019	1E-05	97	0 (0.06)	10	6E-03
Seismic Event <sup>(c)</sup>	1.0E-03	0.016	1E-05	79	0 (0.05)	8.3	5E-03
<b>HIC Operations</b>							
Heavy Equipment Accident with Fire	5.3E-04	0.39	2E-04	2000	1	210	1E-01
Seismic Event	1.0E-03	0.045	3E-05	220	0 (0.1)	23	1E-02
(a) Prob. LCF = the probability of a latent cancer fatality in the hypothetically exposed individual. (b) Number LCFs = the number of latent cancer fatalities in the hypothetically exposed population. Value indicated in parentheses if less than one fatality estimated. (c) This estimate is based on a breach of 500 drums, which is a conservative estimate of the number of stacked, uncovered drums at the face of the waste trenches. Vail (2001c) back-calculates the number of drums breached from the site radiological risk guideline for onsite worker dose and this is not appropriate for this analysis.							

The largest consequences to a non-involved worker would be from a heavy equipment accident with fire involving the HICs. The non-involved worker would receive a dose of about 210 rem and have an 1E-01 probability of an LCF.

**Radiological consequences – MLLW trenches.** The radiological consequences of five accidents at the MLLW trenches were evaluated as part of the Interim Safety Analysis (Vail 2001b). These accidents were a heavy equipment (for example, a bulldozer) accident with fire, a heavy equipment accident with no fire, a drum explosion, a seismic event, and a leachate collection system spray release. These accidents were selected for analysis through a hazard identification and assessment process. Estimated annual frequencies of occurrence range from 4.0E-02 per year for anticipated accidents to 1.0E-02 to 1.0E-04 per year for unlikely accidents. Accident consequences, shown in terms of both radiation dose and LCFs, are presented in Table 5.48.

The largest consequences to the MEI would be from a drum explosion. The MEI would receive a dose of about 4.9E-02 rem and have a 3E-05 probability of a LCF. This accident also results in the largest consequences to the population but no LCFs would be expected.

The largest consequences to a non-involved worker would also be from a drum explosion. The non-involved worker would receive a dose of about 26 rem and have a 2E-02 probability of an LCF.

**Table 5.48.** Radiological Consequences of Accidents at the MLLW Trenches

Accident	Estimated Annual Frequency	Offsite MEI		Offsite Population		Non-Involved Worker	
		Dose (rem)	Prob. LCF <sup>(a)</sup>	Dose (person-rem)	Number LCFs <sup>(b)</sup>	Dose (rem)	Prob. LCF <sup>(a)</sup>
Heavy Equipment Accident with Fire	5.4E-04	0.029	2E-05	140	0 (0.09)	14	8E-03
Heavy Equipment Accident without Fire	1.3E-02	0.0022	1E-06	11	0 (0.007)	1.1	7E-04
Drum Explosion	4.0E-02	0.049	3E-05	240	0 (0.2)	26	2E-02
Seismic Event <sup>(c)</sup>	1.0E-03	0.017	1E-05	83	0 (0.05)	9	5E-03
Leachate Collection System Spray Release	Unlikely <sup>(d)</sup>	0.00048	3E-07	2.4	0 (0.001)	0.25	2E-03

(a) Prob. LCF = the probability of a latent cancer fatality in the hypothetically exposed individual.  
(b) Number LCFs = the number of latent cancer fatalities in the hypothetically exposed population. Value indicated in parentheses if less than one fatality estimated.  
(c) This estimate is based on a breach of 500 drums, which is a conservative estimate of the number of stacked, uncovered drums at the face of the waste trenches. Vail (2001c) back-calculates the number of drums breached from the site radiological risk guideline for onsite worker dose and this is not appropriate for this analysis.  
(d) No frequency provided. Estimated at “unlikely” (1.0E-02 to 1.0E-04).

**Non-radiological (chemical) consequences.** The quantity and form of hazardous constituents in the MLLW trenches are subject to land disposal restrictions and other regulations that are prescriptive in how mixed waste must be treated prior to emplacement. No organic chemicals would be present. The Interim Safety Analysis by Vail (2001b) evaluated four of the previous accidents for non-radiological consequences at the MLLW trenches, including the heavy equipment accident with fire, a heavy equipment accident with no fire, a drum explosion, and a seismic event. Chemicals were assumed to be at the maximum allowable concentrations and the waste was in bulk form (rather than in containers). Accident consequences are presented in Tables 5.49 through 5.52.

For all accidents, the air concentration at the location of the offsite MEI would be well below the TEEL/ERPG-1 level for all chemicals. No impacts would be expected. For the onsite non-involved worker, the TEEL/ERPG-3 levels could be reached or exceeded for three chemicals—molybdenum, nickel, and selenium—for the heavy equipment accident with fire and only selenium for the seismic event. A hypothetically exposed individual may experience or develop a life-threatening effect as a result of a one-hour exposure to any one of these chemicals. The TEEL/ERPG-2 levels would be exceeded for 16 chemicals for the heavy equipment accident with fire, and 13 chemicals for the seismic event. An individual might experience or develop irreversible or other serious health effects or symptoms that might impair the ability to take protective action.

**Radiological consequences – ILAW disposal.** The radiological consequences associated with the disposal of ILAW (as MLLW) in a new disposal facility near the PUREX Plant are addressed in this section. There would be no non-radiological (chemical) consequences due to the processing and physical form of the waste, so non-radiological impacts were not evaluated.

**Table 5.49.** Non-Radiological Air Concentrations for a Heavy Equipment Accident with Fire at the LLBGs

Chemical	Onsite Worker Conc. (mg/m <sup>3</sup> )	Offsite MEI Conc. (mg/m <sup>3</sup> )	TEEL-1 (mg/m <sup>3</sup> )	TEEL-2 (mg/m <sup>3</sup> )	TEEL-3 (mg/m <sup>3</sup> )	Onsite <sup>(a)</sup> TEEL-1 Ratio	Onsite TEEL-2 Ratio	Onsite TEEL-3 Ratio	Offsite <sup>(b)</sup> TEEL-1 Ratio	Offsite TEEL-2 Ratio	Offsite TEEL-3 Ratio
Aluminum	2.0E+02	3.9E-01	30	50	250	6.8	4.1	0.8	1.3E-02	(c)	(c)
Antimony	1.0E+01	2.0E-02	1.5	2.5	50	6.8	4.1	0.2	1.3E-02	(c)	(c)
Arsenic	2.0E-01	3.9E-04	0.03	1.4	5	6.8	0.15	(c)	1.3E-02	(c)	(c)
Barium	1.0E+01	2.0E-02	1.5	2.5	12.5	6.8	4.1	0.8	1.3E-02	(c)	(c)
Beryllium	1.0E-03	2.0E-06	0.005	0.025	0.1	0.2	(c)	(c)	4.0E-04	(c)	(c)
Cadmium	4.1E-02	7.8E-05	0.03	4	9	1.4	0.01	(c)	2.6E-03	(c)	(c)
Calcium hydroxide	1.0E+02	2.0E-01	15	25	500	6.8	4.1	0.2	1.3E-02	(c)	(c)
Chromium	1.0E+01	2.0E-02	1.5	2.5	250	6.8	4.1	0.04	1.3E-02	(c)	(c)
Cobalt	4.1E-01	7.8E-04	0.1	0.1	20	4.1	4.1	0.02	7.8E-03	(c)	(c)
Copper	2.0E+01	3.9E-02	3	5	100	6.8	4.1	0.2	1.3E-02	(c)	(c)
Iron oxide dust	1.0E+02	2.0E-01	15	25	500	6.8	4.1	0.2	1.3E-02	(c)	(c)
Lead	1.0E+00	2.0E-03	0.15	0.25	100	6.8	4.1	0.01	1.3E-02	(c)	(c)
Magnesium	1.0E+02	2.0E-01	30	50	250	3.4	2.0	0.4	6.5E-03	(c)	(c)
Manganese	1.0E+02	2.0E-01	3	5	500	34	20	0.2	6.5E-02	(c)	(c)
Mercury	2.1E-02	4.0E-05	0.025	0.1	10	0.8	(c)	(c)	1.6E-03	(c)	(c)
Molybdenum	1.0E+02	2.0E-01	15	25	60	6.8	4.1	1.7	1.3E-02	(c)	(c)
Nickel	2.0E+01	3.9E-02	4.5	10	10	4.5	2.0	2.0	8.7E-03	(c)	(c)
Potassium hydroxide	4.1E-01	8.0E-04	2	2	150	0.2	(c)	(c)	4.0E-04	(c)	(c)
Selenium	4.1E+00	7.8E-03	0.6	1	1	6.8	4.1	4.1	1.3E-02	(c)	(c)
Silver	2.0E-01	3.9E-04	0.3	0.5	10	0.7	(c)	(c)	1.3E-03	(c)	(c)
Sodium hydroxide	4.1E-01	8.0E-04	0.5	5	50	0.8	(c)	(c)	1.6E-03	(c)	(c)
Thallium	2.0E+00	3.9E-03	0.3	2	15	6.8	1.0	0.1	1.3E-02	(c)	(c)
Vanadium pentoxide	1.0E-01	2.0E-04	0.075	0.5	35	1.4	0.2	(c)	2.7E-03	(c)	(c)
Zinc oxide	2.0E+02	3.9E-01	15	15	500	14	14	0.41	2.6E-02	(c)	(c)

(a) Onsite = non-involved worker.  
(b) Offsite = offsite MEI.  
(c) Ratio not presented because a more restrictive TEEL level was previously met and evaluation of higher TEEL-level ratio is unnecessary.

**Table 5.50.** Non-Radiological Air Concentrations for a Heavy Equipment Accident Without Fire at the LLBGs

Chemical	Onsite Worker Conc. (mg/m <sup>3</sup> )	Offsite MEI Conc. (mg/m <sup>3</sup> )	TEEL-1, (mg/m <sup>3</sup> )	TEEL-2, (mg/m <sup>3</sup> )	TEEL-3, (mg/m <sup>3</sup> )	Onsite <sup>(a)</sup> TEEL-1 Ratio	Onsite TEEL-2 Ratio	Onsite TEEL-3 Ratio	Offsite <sup>(b)</sup> TEEL-1 Ratio	Offsite TEEL-2 Ratio	Offsite TEEL-3 Ratio
Aluminum	4.1E+00	7.8E-03	30	50	250	1.4E-01	(c)	(c)	2.6E-04	(c)	(c)
Antimony	2.0E-01	3.9E-04	1.5	2.5	50	1.4E-01	(c)	(c)	2.6E-04	(c)	(c)
Arsenic	4.1E-03	7.8E-06	0.03	1.4	5	1.4E-01	(c)	(c)	2.6E-04	(c)	(c)
Barium	2.0E-01	3.9E-04	1.5	2.5	12.5	1.4E-01	(c)	(c)	2.6E-04	(c)	(c)
Beryllium	2.1E-05	4.0E-08	0.005	0.025	0.1	4.2E-03	(c)	(c)	8.0E-06	(c)	(c)
Cadmium	8.2E-04	1.6E-06	0.03	4	9	2.7E-02	(c)	(c)	5.2E-05	(c)	(c)
Calcium hydroxide	2.0E+00	3.9E-03	15	25	500	1.4E-01	(c)	(c)	2.6E-04	(c)	(c)
Chromium	2.0E-01	3.9E-04	1.5	2.5	250	1.4E-01	(c)	(c)	2.6E-04	(c)	(c)
Cobalt	8.2E-03	1.6E-05	0.1	0.1	20	8.2E-02	(c)	(c)	1.6E-04	(c)	(c)
Copper	4.1E-01	7.8E-04	3	5	100	1.4E-01	(c)	(c)	2.6E-04	(c)	(c)
Iron oxide dust	2.0E+00	3.9E-03	15	25	500	1.4E-01	(c)	(c)	2.6E-04	(c)	(c)
Lead	2.0E-02	3.9E-05	0.15	0.25	100	1.4E-01	(c)	(c)	2.6E-04	(c)	(c)
Magnesium	2.0E+00	3.9E-03	30	50	250	6.8E-02	(c)	(c)	1.3E-04	(c)	(c)
Manganese	2.0E+00	3.9E-03	3	5	500	6.8E-01	(c)	(c)	1.3E-03	(c)	(c)
Mercury	4.2E-04	8.0E-07	0.025	0.1	10	1.7E-02	(c)	(c)	3.2E-05	(c)	(c)
Molybdenum	2.0E+00	3.9E-03	15	25	60	1.4E-01	(c)	(c)	2.6E-04	(c)	(c)
Nickel	4.1E-01	7.8E-04	4.5	10	10	9.1E-02	(c)	(c)	1.7E-04	(c)	(c)
Potassium hydroxide	8.3E-03	1.6E-05	2	2	150	4.1E-03	(c)	(c)	8.0E-06	(c)	(c)
Selenium	8.2E-02	1.6E-04	0.6	1	1	1.4E-01	(c)	(c)	2.6E-04	(c)	(c)
Silver	4.1E-03	7.8E-06	0.3	0.5	10	1.4E-02	(c)	(c)	2.6E-05	(c)	(c)
Sodium hydroxide	8.3E-03	1.6E-05	0.5	5	50	1.7E-02	(c)	(c)	3.2E-05	(c)	(c)
Thallium	4.1E-02	7.8E-05	0.3	2	15	1.4E-01	(c)	(c)	2.6E-04	(c)	(c)
Vanadium pentoxide	2.1E-03	4.0E-06	0.075	0.5	35	2.8E-02	(c)	(c)	5.3E-05	(c)	(c)
Zinc oxide	4.1E+00	7.8E-03	15	15	500	2.7E-01	(c)	(c)	5.2E-04	(c)	(c)

(a) Onsite = non-involved worker.  
(b) Offsite = offsite MEI.  
(c) Ratio not presented because a more restrictive TEEL level was previously met and evaluation of higher TEEL-level ratio is unnecessary.



**Table 5.51. Non-Radiological Air Concentrations for a Drum Explosion at the LLBGs**

Chemical	Onsite Worker Conc. (mg/m <sup>3</sup> )	Offsite MEI Conc. (mg/m <sup>3</sup> )	TEEL-1 (mg/m <sup>3</sup> )	TEEL-2 (mg/m <sup>3</sup> )	TEEL-3 (mg/m <sup>3</sup> )	Onsite <sup>(a)</sup> TEEL-1 Ratio	Onsite TEEL-2 Ratio	Onsite TEEL-3 Ratio	Offsite <sup>(b)</sup> TEEL-1 Ratio	Offsite TEEL-2 Ratio	Offsite TEEL-3 Ratio
Aluminum	9.3E+00	1.8E-02	30	50	250	3.1E-01	(c)	(c)	5.9E-04	(c)	(c)
Antimony	4.6E-01	8.9E-04	1.5	2.5	50	3.1E-01	(c)	(c)	5.9E-04	(c)	(c)
Arsenic	9.3E-03	1.8E-05	0.03	1.4	5	3.1E-01	(c)	(c)	5.9E-04	(c)	(c)
Barium	4.6E-01	8.9E-04	1.5	2.5	12.5	3.1E-01	(c)	(c)	5.9E-04	(c)	(c)
Beryllium	4.7E-05	9.1E-08	0.005	0.025	0.1	9.4E-03	(c)	(c)	1.8E-05	(c)	(c)
Cadmium	1.9E-03	3.6E-06	0.03	4	9	6.2E-02	(c)	(c)	1.2E-04	(c)	(c)
Calcium hydroxide	4.6E+00	8.9E-03	15	25	500	3.1E-01	(c)	(c)	5.9E-04	(c)	(c)
Chromium	4.6E-01	8.9E-04	1.5	2.5	250	3.1E-01	(c)	(c)	5.9E-04	(c)	(c)
Cobalt	1.9E-02	3.6E-05	0.1	0.1	20	1.9E-01	(c)	(c)	3.6E-04	(c)	(c)
Copper	9.3E-01	1.8E-03	3	5	100	3.1E-01	(c)	(c)	5.9E-04	(c)	(c)
Iron oxide dust	4.6E+00	8.9E-03	15	25	500	3.1E-01	(c)	(c)	5.9E-04	(c)	(c)
Lead	4.6E-02	8.9E-05	0.15	0.25	100	3.1E-01	(c)	(c)	5.9E-04	(c)	(c)
Magnesium	4.6E+00	8.9E-03	30	50	250	1.5E-01	(c)	(c)	3.0E-04	(c)	(c)
Manganese	4.6E+00	8.9E-03	3	5	500	1.5E+00	0.9	(c)	3.0E-03	(c)	(c)
Mercury	9.4E-04	1.8E-06	0.025	0.1	10	3.8E-02	(c)	(c)	7.3E-05	(c)	(c)
Molybdenum	4.6E+00	8.9E-03	15	25	60	3.1E-01	(c)	(c)	5.9E-04	(c)	(c)
Nickel	9.3E-01	1.8E-03	4.5	10	10	2.1E-01	(c)	(c)	4.0E-04	(c)	(c)
Potassium hydroxide	1.9E-02	3.6E-05	2	2	150	9.4E-03	(c)	(c)	1.8E-05	(c)	(c)
Selenium	1.9E-01	3.6E-04	0.6	1	1	3.1E-01	(c)	(c)	5.9E-04	(c)	(c)
Silver	9.3E-03	1.8E-05	0.3	0.5	10	3.1E-02	(c)	(c)	5.9E-05	(c)	(c)
Sodium hydroxide	1.9E-02	3.6E-05	0.5	5	50	3.8E-02	(c)	(c)	7.3E-05	(c)	(c)
Thallium	9.3E-02	1.8E-04	0.3	2	15	3.1E-01	(c)	(c)	5.9E-04	(c)	(c)
Vanadium pentoxide	4.7E-03	9.1E-06	0.075	0.5	35	6.3E-02	(c)	(c)	1.2E-04	(c)	(c)
Zinc oxide	9.3E+00	1.8E-02	15	15	500	6.2E-01	(c)	(c)	1.2E-03	(c)	(c)

(a) Onsite = non-involved worker.  
(b) Offsite = offsite MEI.  
(c) Ratio not presented because a more restrictive TEEL level was previously met and evaluation of higher TEEL-level ratio is unnecessary.

**Table 5.52.** Non-Radiological Air Concentrations for a Seismic Event Without Fire at the LLBGs

Chemical	Onsite Worker Conc. (mg/m <sup>3</sup> )	Offsite MEI Conc. (mg/m <sup>3</sup> )	TEEL-1 (mg/m <sup>3</sup> )	TEEL-2 (mg/m <sup>3</sup> )	TEEL-3 (mg/m <sup>3</sup> )	Onsite <sup>(a)</sup> TEEL-1 Ratio	Onsite TEEL-2 Ratio	Onsite TEEL-3 Ratio	Offsite <sup>(b)</sup> TEEL-1 Ratio	Offsite TEEL-2 Ratio	Offsite TEEL-3 Ratio
Aluminum	7.4E+01	1.4E-01	30	50	250	2.5	1.5	0.3	4.8E-03	(c)	(c)
Antimony	3.7E+00	7.1E-03	1.5	2.5	50	2.5	1.5	0.07	4.8E-03	(c)	(c)
Arsenic	7.4E-02	1.4E-04	0.03	1.4	5	2.5	0.05	(c)	4.8E-03	(c)	(c)
Barium	3.7E+00	7.1E-03	1.5	2.5	12.5	2.5	1.5	0.3	4.8E-03	(c)	(c)
Beryllium	3.8E-04	7.3E-07	0.005	0.025	0.1	0.08	(c)	(c)	1.5E-04	(c)	(c)
Cadmium	1.5E-02	2.9E-05	0.03	4	9	0.5	(c)	(c)	9.5E-04	(c)	(c)
Calcium hydroxide	3.7E+01	7.1E-02	15	25	500	2.5	1.5	0.1	4.8E-03	(c)	(c)
Chromium	3.7E+00	7.1E-03	1.5	2.5	250	2.5	1.5	0.01	4.8E-03	(c)	(c)
Cobalt	1.5E-01	2.9E-04	0.1	0.1	20	1.5	1.5	7.4E-03	2.9E-03	(c)	(c)
Copper	7.4E+00	1.4E-02	3	5	100	2.5	1.5	0.07	4.8E-03	(c)	(c)
Iron oxide dust	3.7E+01	7.1E-02	15	25	500	2.5	1.5	0.1	4.8E-03	(c)	(c)
Lead	3.7E-01	7.1E-04	0.15	0.25	100	2.5	1.5	0.004	4.8E-03	(c)	(c)
Magnesium	3.7E+01	7.1E-02	30	50	250	1.2	0.7	(c)	2.4E-03	(c)	(c)
Manganese	3.7E+01	7.1E-02	3	5	500	12	7.4	0.07	2.4E-02	(c)	(c)
Mercury	7.6E-03	1.5E-05	0.025	0.1	10	0.3	(c)	(c)	5.8E-04	(c)	(c)
Molybdenum	3.7E+01	7.1E-02	15	25	60	2.5	1.5	0.6	4.8E-03	(c)	(c)
Nickel	7.4E+00	1.4E-02	4.5	10	10	1.6	0.7	(c)	3.2E-03	(c)	(c)
Potassium hydroxide	1.5E-01	2.9E-04	2	2	150	0.08	(c)	(c)	1.5E-04	(c)	(c)
Selenium	1.5E+00	2.9E-03	0.6	1	1	2.5	1.5	1.5	4.8E-03	(c)	(c)
Silver	7.4E-02	1.4E-04	0.3	0.5	10	0.2	(c)	(c)	4.8E-04	(c)	(c)
Sodium hydroxide	1.5E-01	2.9E-04	0.5	5	50	0.3	(c)	(c)	5.8E-04	(c)	(c)
Thallium	7.4E-01	1.4E-03	0.3	2	15	2.5	0.4	(c)	4.8E-03	(c)	(c)
Vanadium pentoxide	3.8E-02	7.3E-05	0.075	0.5	35	0.5	(c)	(c)	9.7E-04	(c)	(c)
Zinc oxide	7.4E+01	1.4E-01	15	15	500	5	5	0.15	9.5E-03	(c)	(c)

(a) Onsite = non-involved worker.  
(b) Offsite = offsite MEI.  
(c) Ratio not presented because a more restrictive TEEL was previously met and evaluation of higher TEEL-level ratio is unnecessary.

A preliminary hazards assessment (Burbank 2002) identified 198 hazardous conditions grouped into 15 accident categories; quantitative results were reported for two accidents. A bulldozer accident was assumed to occur and shear off the tops of six ILAW containers. A crane accident had the crane falling into a trench with the boom striking an exposed container array 10 packages wide by 5 packages wide. Accident consequences, shown in terms of both radiation dose and LCF, are presented in Table 5.53.

The largest consequences to the MEI would be from the crane accident. The MEI would receive a dose of about 3.0E-05 rem and have a 2E-08 probability of an LCF. This accident also results in the largest consequences to the population, with about a 5E-05 probability of an LCF.

The largest consequences to workers would also be from the crane accident. The non-involved worker would receive a dose of about 0.04 rem and have a 3E-05 probability of an LCF.

**LLBGs industrial accidents.** This section addresses potential health and safety impacts from construction and operation of LLW and MLLW trenches and supporting facilities (pulse driers) in the LLBGs. Estimated health and safety impacts from construction and operation of MLLW trenches are included in totals for the LLBGs presented below.

**LLBGs industrial accidents – construction.** Construction of new trenches and pulse driers for MLLW trenches would require a total of 7 to 10 worker-years. The estimated health and safety impacts would be less than one total recordable case and less than one lost workday case.

**LLBGs industrial accidents – operations.** Direct operations staffing in the LLBGs would total 3800 worker-years. Estimated health and safety impacts would be 100 total recordable cases, 42 lost workday cases, and 1500 lost workdays.

**ILAW industrial accidents.** Industrial impacts are not separated by construction and operations. A total of about 5000 worker-years would be required for construction, operations, and closure. The estimated health and safety impacts would be about 200 total recordable cases, 84 lost workday cases, and about 2900 lost workdays.

**Table 5.53.** Radiological Consequences of Accidents Involving ILAW Disposal

Accident	Estimated Annual Frequency	Offsite MEI		Population		Non-Involved Worker	
		Dose (rem)	Prob. LCF <sup>(a)</sup>	Dose (person -rem)	Number LCFs <sup>(b)</sup>	Dose (rem)	Prob. LCF <sup>(a)</sup>
Bulldozer Accident	NA	1.9E-05	1E-08	5.0E-02	3E-05	2.3E-02	1E-05
Crane Accident	NA	3.4E-05	2E-08	9.0E-02	5E-05	4.3E-02	3E-05
(a) Prob. LCF = the probability of a latent cancer fatality in the hypothetically exposed individual. (b) Number LCFs = the number of latent cancer fatalities in the hypothetically exposed population. Value indicated in parentheses if less than one fatality estimated. NA = not available.							

### **5.11.1.2 Alternative Group B**

Alternative Group B is similar to Alternative Group A except that use of commercial treatment facilities would be minimized with construction of a new waste processing facility, instead of modifying the T Plant Complex. New LLW and MLLW trenches would be constructed using the current design instead of the wider, deeper trench designs. Alternative Group B would involve the same waste processing and the same waste management approaches. The alternative includes the establishment of necessary facilities for storage, inspection, treatment, and final disposal or shipment offsite for all included waste streams. In addition, Alternative Group B includes the same sources, waste streams, and volumes of waste as Alternative Group A.

As in Alternative Group A, all of the wastes would be removed from storage and treated as necessary for disposal in the HSW disposal facilities or sent to the WIPP. After about 10 years, wastes would only be held in storage for short periods of time to allow for characterization and evaluation prior to treatment or disposal. Under Alternative Group B, the analyses use the Hanford Only, Upper, and Lower Bound of forecasted disposal waste volumes for LLW and MLLW.

#### **5.11.1.2.1 Construction**

New construction activities are anticipated for HSW disposal facilities and the new waste processing facility. The primary impacts from construction activities would be to air quality and injuries to construction workers. No impacts to construction workers are expected from radiation and chemicals because new construction activities would be performed away from areas of known contamination. Impacts to non-involved workers (from other onsite activities) are expected to bound potential air quality impacts to construction workers. Impacts from industrial accidents during construction are discussed in Section 5.11.1.2.3.

The construction activities may involve emission of criteria pollutants from the use of combustion engines and earthmoving activities. The potential impacts from these activities are described in Section 5.2 and are summarized here. Impacts are measured by comparing air concentrations at the point of maximum potential public exposure. The analysis indicated that emissions of criteria pollutants (including sulfur dioxide, carbon monoxide, nitrogen dioxide, and PM<sub>10</sub>) from construction activities would result in air concentrations below the regulatory limits. As a consequence, no health impacts would be expected from these emissions.

#### **5.11.1.2.2 Normal Operations**

Potential impacts to public health from normal operations include air quality impacts from atmospheric releases of radionuclides and chemicals from waste operations. Long-term impacts from releases to groundwater from LLBGs are discussed in Sections 5.11.2 and 5.3.

Alternative Group B involves operations that may result in routine releases of radionuclides and chemicals to the atmosphere. These operations include waste package verification, treatment, and packaging at WRAP; processing of materials and equipment at the modified T Plant Complex; treatment and processing of waste in the new waste processing facility; and treatment of leachate from MLLW

trenches using pulse driers. Annual releases have been estimated for each year of operation for the facilities involved in this alternative. Details of the release calculations are described in Volume II, Appendix F.

#### **5.11.1.2.2.1 Health Impacts from Routine Radionuclide Releases**

The expected doses and health impacts to non-involved workers and the public from routine atmospheric releases of radionuclides are presented in Table 5.54 for the Hanford Only waste volume, Table 5.55 for the Lower Bound waste volume, and in Table 5.56 for the Upper Bound waste volume. The tables present the maximum annual dose to the non-involved workers and the MEI, and the collective dose to the public along with the probability of developing an LCF for the individual and the number of LCFs expected for the public. Given that the cancer risk estimates and doses are small in comparison to regulatory limits,<sup>(a)</sup> no adverse health impacts would be expected from radionuclide releases.

#### **5.11.1.2.2.2 Health Impacts from Chemical Releases**

Releases of chemicals to the atmosphere could occur for the same processes involving release of radionuclides when wastes with hazardous chemicals are involved. The potential health impacts from chemical releases to the atmosphere are presented in Table 5.57 for all waste volumes. The results for the Hanford Only waste volume are the same as those for the Lower Bound waste volume because the processing volumes for mixed waste streams are nearly identical for both (only mixed wastes contain chemicals that may be released to the atmosphere). Because all the peak hazard quotients are less than 1, and because the cancer risk estimates are small, no adverse health impacts would be expected from chemical releases.

#### **5.11.1.2.2.3 Worker Occupational Radiation Exposure**

The radiation dose received by workers involved with waste operations is estimated using historical exposure data for the facilities involved in the alternative as provided the Technical Information Document (FH 2004). The potential radiation exposure to workers for Alternative Group B are summarized in Table 5.58 for the Hanford Only waste volume, in Table 5.59 for the Lower Bound waste volume, and in Table 5.60 for the Upper Bound waste volume. All estimated radiation doses to workers are well below regulatory limits.<sup>(b)</sup>

---

(a) The maximum annual radiation dose presented in this section may be compared to the regulatory limit of 10 mrem/year (WAC 246-247; 40 CFR 61; DOE 1993).

(b) The annual limit for occupational exposures is 5000 mrem/year (10 CFR 835).

**Table 5.54.** Non-Involved Worker and Public Health Impacts from Routine Atmospheric Releases of Radionuclides – Alternative Group B, Hanford Only Waste Volume

Exposed Group	Exposure Scenario <sup>(a)</sup>	Facility	Lifetime Dose <sup>(b)</sup> (mrem)	Prob. of LCFs <sup>(c)</sup>	Maximum Annual Dose	
					Year	mrem
Worker Onsite (non-involved)	Industrial	WRAP	1.2E-03	7E-10	2004	1.3E-04
		T Plant Complex	4.8E-01	3E-07	2003	3.9E-02
		NWPF <sup>(d)</sup>	2.8E-02	2E-08	2015	2.0E-03
		Leachate Treatment <sup>(e,f)</sup>	6.9E-08	4E-14	2026	4.9E-09
MEI Offsite	Resident Gardener	WRAP	9.9E-05	6E-11	2004	1.1E-05
		T Plant Complex	1.0E-03	6E-10	2003	7.9E-05
		NWPF	9.7E-04	6E-10	2015	6.7E-05
		Leachate Treatment	2.2E-10	1E-16	2027	1.2E-11
		Total	2.1E-03	1E-09	2003	1.6E-04
			(person-rem)	Number of LCFs <sup>(g)</sup>	Year	(person-rem)
Population <sup>(h)</sup>	Population within 80 km (50 mi)	WRAP	9.1E-03	0 (5E-06)	2004	7.4E-04
		T Plant Complex	9.2E-02	0 (6E-05)	2003	5.5E-03
		NWPF	8.8E-02	0 (5E-05)	2015	4.7E-03
		Leachate Treatment	2.0E-08	0 (1E-11)	2026	8.2E-10
		Total	1.9E-01	0 (1E-04)	2003	1.1E-02
<p>(a) The exposure duration for the industrial scenario is 20 years and for the resident gardener, 30 years. The exposure scenarios are described in Volume II, Appendix F.</p> <p>(b) The lifetime dose is the radiation dose received from intake during the exposure period and up to 50 years after exposure due to radionuclides deposited in the body during the exposure period.</p> <p>(c) LCF = latent cancer fatality.</p> <p>(d) NWPF = new waste processing facility.</p> <p>(e) Leachate treatment is a pulse drier operation.</p> <p>(f) If LLW trenches were to be lined, the doses from leachate collection and treatment might be as much as three times the leachate treatment values shown in this table.</p> <p>(g) The value in parentheses is the calculated value based on the population dose and the appropriate health effects conversion factor. The actual number of LCFs must be a whole number (deaths).</p> <p>(h) The population lifetime impacts are based on exposure for the same exposure pathways impacting the resident gardener MEI.</p>						

**Table 5.55.** Non-Involved Worker and Public Health Impacts from Routine Atmospheric Releases of Radionuclides – Alternative Group B, Lower Bound Waste Volume

Exposed Group	Exposure Scenario <sup>(a)</sup>	Facility	Lifetime Dose <sup>(b)</sup> (mrem)	Prob. of LCFs <sup>(c)</sup>	Maximum Annual Dose	
					Year	Mrem
Worker Onsite (non-involved)	Industrial	WRAP	1.4E-03	9E-10	2004	1.6E-04
		T Plant Complex	5.8E-01	3E-07	2003	4.8E-02
		NWPF <sup>(d)</sup>	2.8E-02	2E-08	2015	2E-03
		Leachate Treatment <sup>(e,f)</sup>	5.0E-07	3E-13	2026	2.8E-08
MEI Offsite	Resident Gardener	WRAP	1.2E-04	7E-11	2004	1.3E-05
		T Plant Complex	1.2E-03	7E-10	2003	9.5E-05
		NWPF	9.7E-04	6E-10	2015	6.7E-05
		Leachate Treatment	2.6E-10	2E-16	2027	1.4E-11
		Total	2.3E-03	1E-09	2003	1.8E-04
			(person-rem)	Number of LCFs <sup>(g)</sup>	Year	(person-rem)
Population <sup>(h)</sup>	Population within 80 km (50 mi)	WRAP	1.1E-02	0 (6E-06)	2004	8.8E-04
		T Plant Complex	1.1E-01	0 (7E-05)	2003	6.7E-03
		NWPF	8.8E-02	0 (5E-05)	2015	4.7E-03
		Leachate Treatment	2.3E-08	0 (1E-11)	2026	9.6E-10
		Total	2.1E-01	0 (1E-04)	2003	1.3E-02
<p>(a) The exposure duration for the industrial scenario is 20 years and for the resident gardener, 30 years. The exposure scenarios are described in Volume II, Appendix F.</p> <p>(b) The lifetime dose is the radiation dose received from intake during the exposure period and up to 50 years after exposure due to radionuclides deposited in the body during the exposure period.</p> <p>(c) LCF = latent cancer fatality.</p> <p>(d) NWPF = new waste processing facility.</p> <p>(e) Leachate treatment is a pulse drier operation.</p> <p>(f) If LLW trenches were to be lined, the doses from leachate collection and treatment might be as much as three times the leachate treatment values shown in this table.</p> <p>(g) The value in parentheses is the calculated value based on the population dose and the appropriate health effects conversion factor. The actual number of LCFs must be a whole number (deaths).</p> <p>(h) The population lifetime impacts are based on exposure for the same exposure pathways impacting the resident gardener MEI.</p>						

**Table 5.56.** Non-Involved Worker and Public Health Impacts from Routine Atmospheric Releases of Radionuclides – Alternative Group B, Upper Bound Waste Volume

Exposed Group	Exposure Scenario <sup>(a)</sup>	Facility	Lifetime Dose <sup>(b)</sup> (mrem)	Prob. of LCFs <sup>(c)</sup>	Maximum Annual Dose	
					Year	mrem
Worker Onsite (non-involved)	Industrial	WRAP	2.2E-03	1E-09	2004	1.9E-04
		T Plant Complex	8.9E-01	5E-07	2006	7.2E-02
		NWPF <sup>(d)</sup>	2.8E-02	2E-08	2015	2.0E-03
		Leachate Treatment <sup>(e,f)</sup>	8.4E-07	5E-13	2026	4.7E-08
MEI Offsite	Resident Gardener	WRAP	2.1E-04	1E-10	2004	1.6E-05
		T Plant Complex	2.0E-03	1E-09	2006	1.5E-04
		NWPF	9.7E-04	6E-10	2015	6.7E-05
		Leachate Treatment	4.3E-10	3E-16	2026	2.3E-11
		Total	3.2E-03	2E-09	2006	2.3E-04
			<b>Dose (person-rem)</b>	<b>Number of LCFs<sup>(g)</sup></b>	<b>Year</b>	<b>Dose (person-rem)</b>
Population <sup>(h)</sup>	Population within 80 km (50 mi)	WRAP	2.0E-02	0 (1E-05)	2004	1.1E-03
		T Plant Complex	1.8E-01	0 (1E-04)	2006	1.0E-02
		NWPF	8.8E-02	0 (5E-05)	2015	4.7E-03
		Leachate Treatment	3.9E-08	0 (2E-11)	2026	1.9E-09
		Total	2.9E-01	0 (2E-04)	2006	1.6E-02
<p>(a) The exposure duration for the industrial scenario is 20 years and for the resident gardener, 30 years. The exposure scenarios are described in Volume II, Appendix F.</p> <p>(b) The lifetime dose is the radiation dose received from intake during the exposure period and up to 50 years after exposure due to radionuclides deposited in the body during the exposure period.</p> <p>(c) LCF = latent cancer fatality.</p> <p>(d) NWPF = new waste processing facility.</p> <p>(e) Leachate treatment is a pulse drier operation.</p> <p>(f) If LLW trenches were to be lined, the doses from leachate collection and treatment might be as much as three times the leachate treatment values shown in this table.</p> <p>(g) The value in parentheses is the calculated value based on the population dose and the appropriate health effects conversion factor. The actual number of LCFs must be a whole number (deaths).</p> <p>(h) The population lifetime impacts are based on exposure for the same exposure pathways impacting the resident gardener MEI.</p>						



**Table 5.57.** Non-Involved Worker and Public Health Impacts from Routine Atmospheric Releases of Chemicals – Alternative Group B, All Waste Volumes

Volume	Exposed Group	Exposure Scenario <sup>(a)</sup>	Facility	Risk of Cancer Incidence <sup>(b)</sup>	Peak Annual Hazard Quotient <sup>(c)</sup>
Hanford Only and Lower Bound	Worker Onsite (non-involved)	Industrial	WRAP	1.2E-09	8.9E-05
			T Plant Complex	3.2E-08	2.3E-03
			NWPF <sup>(d)</sup>	1.7E-07	9.1E-03
	MEI Offsite	Resident Gardener	WRAP	5.6E-11	3.4E-06
			T Plant Complex	3.3E-11	2.0E-06
			NWPF	6.9E-09	3.7E-04
			Total	7.0E-09	3.8E-04
	Population	Population within 80 km (50 mi)	WRAP	0 (5.0E-06) <sup>(e)</sup>	NA <sup>(f, g)</sup>
			T Plant Complex	0 (3.0E-06) <sup>(e)</sup>	NA
			NWPF	0 (6.0E-04) <sup>(e)</sup>	NA
Total			0 (6.0E-04) <sup>(e)</sup>	NA	
Upper Bound	Worker Onsite (non-involved)	Industrial	WRAP	5.3E-09	6.9E-04
			T Plant Complex	1.8E-07	2.4E-02
			NWPF	1.7E-07	9.1E-03
	MEI Offsite	Resident Gardener	WRAP	2.3E-10	2.5E-05
			T Plant Complex	1.7E-10	2.0E-05
			NWPF	6.9E-09	3.7E-04
			Total	7.3E-09	4.2E-04
	Population	Population within 80 km (50 mi)	WRAP	0 (2.0E-05) <sup>(e)</sup>	NA <sup>(f, g)</sup>
			T Plant Complex	0 (2.0E-05) <sup>(e)</sup>	NA
			NWPF	0 (6.0E-04) <sup>(e)</sup>	NA
Total			0 (7.0E-04) <sup>(e)</sup>	NA	
<p>(a) The exposure duration for the industrial scenario is 20 years and for the resident gardener, 30 years. The exposure scenarios are described in Volume II, Appendix F.</p> <p>(b) The individual risk of cancer incidence is evaluated for the exposure duration defined for the given exposure scenario starting in the year that provides the highest total impact.</p> <p>(c) Hazard quotients are reported for the year of highest exposure.</p> <p>(d) NWPF = new waste processing facility.</p> <p>(e) Population risk from cancer is expressed as the inferred number of fatal and non-fatal cancers in the exposed population over the lifetime of the population from intakes during the remediation period. The actual value must be a whole number (cancers).</p> <p>(f) Hazard quotients are designed as a measure of impacts on an individual and are not meaningful for population exposures.</p> <p>(g) NA = not applicable.</p>					

**Table 5.58.** Occupational Radiation Exposure – Alternative Group B, Hanford Only Waste Volume

Facility	Operating Period	Worker Category <sup>(a)</sup>	Workers (FTE) <sup>(b)</sup>	Average Dose Rate (mrem/yr)	Workforce Dose (person-rem)	Workforce LCFs <sup>(c)</sup>
LLW and MLLW Trenches	2002–2046	Operator	14	54	34	0 (2E-02)
		RCT	4	45	8.5	0 (5E-03)
		Other	66	35	104	0 (6E-02)
ILAW	2008–2028	Workers	70	300 <sup>(e)</sup>	443	0 (3E-01)
	2032–2046	Workers	20	14	4.1	0 (2E-03)
CWC	2002–2046	Operator	12	54	29	0 (2E-02)
		RCT	4	45	8.6	0 (5E-03)
		Other	55	17	42	0 (3E-02)
WRAP	2002–2032	Operator	13	18	7.3	0 (4E-03)
		RCT	9	36	10	0 (6E-03)
		Other	29	13	12	0 (7E-03)
	2033–2039	Operator	9	18	1.1	0 (7E-04)
		RCT	6	36	1.6	0 (1E-03)
		Other	20	13	1.9	0 (1E-03)
T Plant Complex	2002–2032	Operator	20	9	5.6	0 (3E-03)
		RCT	18	13	7.3	0 (4E-03)
		Other	38	7	8.2	0 (5E-03)
	2033–2046	Operator	14	9	1.7	0 (1E-03)
		RCT	13	13	2.3	0 (1E-03)
		Other	27	7	2.6	0 (4E-03)
New Waste Processing Facility	2013–2031	Operator	10	13	2.6	0 (2E-03)
		RCT	10	13	2.4	0 (1E-03)
		Other	20	13	4.9	0 (3E-03)
Generator Staff <sup>(f)</sup>	2002–2019	Operator	15	34	9.2	0 (6E-03)
		RCT	12	35	7.6	0 (5E-03)
	2020–2026	Operator	5	34	1.2	0 (7E-04)
		RCT	3	35	0.7	0 (4E-04)
	2027–2044	Operator	1	34	0.6	0 (4E-04)
		RCT	1	35	0.6	0 (4E-04)
Pulse Driers	2026–2077	Operator <sup>(d)</sup>	2.8	54	8.0	0 (5E-03)
<b>Total</b>					<b>772</b>	<b>0 (4.6E-01)</b>
<p>(a) RCT = radiation control technician.</p> <p>(b) The number of workers is the average necessary for the facility during the indicated period.</p> <p>(c) LCF = latent cancer fatality. Workforce LCFs are the inferred number of cancer deaths in the exposed workforce, which must be a whole number (deaths). The value in parentheses is the calculated value based on the workforce dose and the appropriate health effects conversion factor.</p> <p>(d) Operators are provided by contract with the vendor operating the pulse drier unit. Radiological monitoring (RCT) resources are included with the RCT resources for LLW/MLLW trenches.</p> <p>(e) The dose rates for placement of ILAW into disposal facilities are higher than for other solid waste management operations because the material emits more radiation.</p> <p>(f) Staff in the solid waste support services group that work as needed in various solid waste facilities.</p>						

**Table 5.59.** Occupational Radiation Exposure – Alternative Group B, Lower Bound Waste Volume

Facility	Operating Period	Worker Category <sup>(a)</sup>	Workers (FTE) <sup>(b)</sup>	Average Dose Rate (mrem/yr)	Workforce Dose (person-rem)	Workforce LCFs <sup>(c)</sup>
LLW and MLLW Trenches	2002–2046	Operator	14	54	34	0 (2E-02)
		RCT	4	45	8.5	0 (5E-03)
		Other	66	35	104	0 (6E-02)
ILAW	2008–2028	Workers	70	300 <sup>(e)</sup>	443	0 (3E-01)
	2032–2046	Workers	20	14	4.1	0 (2E-03)
CWC	2002–2046	Operator	12	54	29	0 (2E-02)
		RCT	4	45	8.6	0 (5E-03)
		Other	55	17	42	0 (3E-02)
WRAP	2002–2032	Operator	13	18	7.3	0 (4E-03)
		RCT	9	36	10	0 (6E-03)
		Other	29	13	12	0 (7E-03)
	2033–2039	Operator	9	18	1.1	0 (7E-04)
		RCT	6	36	1.6	0 (1E-03)
		Other	20	13	1.9	0 (1E-03)
T Plant Complex	2002–2032	Operator	20	9	5.6	0 (3E-03)
		RCT	18	13	7.3	0 (4E-03)
		Other	38	7	8.2	0 (5E-03)
	2033–2046	Operator	14	9	1.7	0 (1E-03)
		RCT	13	13	2.3	0 (1E-03)
		Other	27	7	2.6	0 (4E-03)
New Waste Processing Facility	2013–2031	Operator	10	13	2.6	0 (2E-03)
		RCT	10	13	2.4	0 (1E-03)
		Other	20	13	4.9	0 (3E-03)
Generator Staff <sup>(f)</sup>	2002–2019	Operator	15	34	9.2	0 (6E-03)
		RCT	12	35	7.6	0 (5E-03)
	2020–2026	Operator	5	34	1.2	0 (7E-04)
		RCT	3	35	0.7	0 (4E-04)
	2027–2044	Operator	1	34	0.6	0 (4E-04)
		RCT	1	35	0.6	0 (4E-04)
Pulse Driers	2026–2077	Operator <sup>(d)</sup>	3.3	54	9.4	0 (6E-03)
<b>Total</b>					<b>773</b>	<b>0 (4.6E-01)</b>
<p>(a) RCT = radiation control technician.</p> <p>(b) The number of workers is the average necessary for the facility during the indicated period.</p> <p>(c) LCF = latent cancer fatality. Workforce LCFs are the inferred number of cancer deaths in the exposed workforce, which must be a whole number (deaths). The value in parentheses is the calculated value based on the workforce dose and the appropriate health effects conversion factor.</p> <p>(d) Operators are provided by contract with the vendor operating the pulse drier unit. Radiological monitoring (RCT) resources are included with the RCT resources for LLW/MLLW trenches.</p> <p>(e) The dose rates for placement of ILAW into disposal facilities are higher than for other solid waste management operations because the material emits more radiation.</p> <p>(f) Staff in the solid waste support services group that work as needed in various solid waste facilities.</p>						

**Table 5.60.** Occupational Radiation Exposure – Alternative Group B, Upper Bound Waste Volume

Facility	Operating Period	Worker Category <sup>(a)</sup>	Workers (FTE) <sup>(b)</sup>	Average Dose Rate (mrem/yr)	Workforce Dose (person-rem)	Workforce LCFs <sup>(c)</sup>
LLW and MLLW Trenches	2002–2046	Operator	14	54	34	0 (2E-02)
		RCT	4	45	8.5	0 (5E-03)
		Other	66	35	104	0 (6E-02)
ILAW	2008–2028	Workers	70	300 <sup>(e)</sup>	443	0 (3E-01)
	2032–2046	Workers	20	14	4.1	0 (2E-03)
CWC	2002–2046	Operator	12	54	29	0 (2E-02)
		RCT	4	45	8.6	0 (5E-03)
		Other	55	17	42	0 (3E-02)
WRAP	2002–2032	Operator	13	18	7.3	0 (4E-03)
		RCT	9	36	10	0 (6E-03)
		Other	29	13	12	0 (7E-03)
	2033–2039	Operator	9	18	1.2	0 (7E-04)
		RCT	6	36	1.6	0 (1E-03)
		Other	21	13	1.9	0 (1E-03)
T Plant Complex	2002–2032	Operator	20	9	5.6	0 (3E-03)
		RCT	18	13	7.3	0 (4E-03)
		Other	38	7	8.2	0 (5E-03)
	2033–2046	Operator	14	9	1.7	0 (1E-03)
		RCT	13	13	2.3	0 (1E-03)
		Other	27	7	2.6	0 (2E-03)
New Waste Processing Facility	2013–2031	Operator	10	13	2.6	0 (2E-03)
		RCT	10	13	2.4	0 (1E-03)
		Other	20	13	4.9	0 (3E-03)
Generator Staff <sup>(f)</sup>	2002–2019	Operator	20	34	12	0 (7E-03)
		RCT	13	35	8.2	0 (5E-03)
	2020–2026	Operator	7	34	1.7	0 (1E-03)
		RCT	5	35	1.2	0 (7E-04)
	2027–2044	Operator	3	34	1.8	0 (1E-03)
		RCT	2	35	1.3	0 (8E-04)
Pulse Driers	2026–2077	Operator <sup>(d)</sup>	5.6	54	16	0 (9E-03)
<b>Total</b>					<b>786</b>	<b>0 (4.7E-01)</b>
<p>(a) RCT = radiation control technician.</p> <p>(b) The number of workers is the average necessary for the facility during the indicated period.</p> <p>(c) LCF = latent cancer fatality. Workforce LCFs are the inferred number of cancer deaths in the exposed workforce, which must be a whole number (deaths). The value in parentheses is the calculated value based on the workforce dose and the appropriate health effects conversion factor.</p> <p>(d) Operators are provided by contract with the vendor operating the pulse drier unit. Radiological monitoring (RCT) resources are included with the RCT resources for LLW/MLLW trenches.</p> <p>(e) The dose rates for placement of ILAW into disposal facilities are higher than for other solid waste management operations because the material emits more radiation.</p> <p>(f) Staff in the solid waste support services group that work as needed in various solid waste facilities.</p>						

### **5.11.1.2.3 Accidents**

The impacts of accidents involving radiological and chemical contaminants and industrial accidents are evaluated in this section. The impacts of these accidents are expected to bound impacts of events that could be initiated by malevolent intent. Continuing waste management operations under Alternative Group B would involve a continuing potential for accidental release that would be very similar to those discussed for Alternative Group A in four Hanford facilities: the CWC for waste storage, the WRAP for waste treatment, the modified T Plant Complex for waste treatment, and the HSW disposal facilities for waste disposal. Alternative Group B also adds a new treatment facility, the new waste processing facility, for which potential health impacts from accidents were evaluated. Health and safety impacts from industrial accidents would differ only slightly from Alternative Group A from construction activities for the new waste processing facility and LLBGs under Alternative Group B.

Anticipated health impacts to all workers from industrial accidents during construction and operations would be 640 to 660 total recordable cases, 260 to 270 lost workday cases, and 9000 to 9300 lost workdays. A total of about 20,800 to 21,400 worker-years would be required to complete all activities. Of these worker-years about 2800 to 3400 are site support and waste generator-paid workers that do not appear in the direct facility worker and impact estimates in the following sections. About 94 to 97 percent of these health impacts are from operations.

#### **5.11.1.2.3.1 Storage – CWC**

Potential radiological, non-radiological, and industrial accidents and impacts for the CWC would be the same as for Alternative Group A (see Section 5.11.1.1.3.1).

#### **5.11.1.2.3.2 Treatment – WRAP**

Potential radiological, non-radiological, and industrial accidents and impacts for the WRAP would be the same as for Alternative Group A (see Section 5.11.1.1.3.2).

#### **5.11.1.2.3.3 Treatment – T Plant Complex**

Potential radiological, non-radiological, and industrial accidents and impacts for continuing the existing T Plant activities are described under Alternative Group A (see Section 5.11.1.1.3.3).

#### **5.11.1.2.3.4 Treatment – New Waste Processing Facility**

The DOE would construct a new waste processing treatment facility in the 200 West Area to augment existing capabilities for treatment of contact-handled (CH) MLLW. DOE would provide onsite treatment for CH MLLW at this facility in addition to non-standard, remote-handled (RH) MLLW and TRU waste.

**Radiological consequences.** Radiological consequences of accidents would be the same as those described for the modified T Plant Complex described under Alternative Group A (see Section 5.11.1.1.3.3).

**Non-radiological (chemical) consequences.** Non-radiological consequences for the new waste processing facility have not been evaluated in detail. However, potential non-radiological impacts from accidents in the WRAP and the modified T Plant Complex are expected to be representative of potential impacts from the new waste processing facility. Potential impacts from accidents in the CWC and LLBGs would likely be bounding for accidents in the new waste processing facility.

**Industrial accidents – construction.** Direct employment for the new waste processing facility construction would total 278 worker-years. The estimated health and safety impacts would be 23 total recordable cases, 8 lost workday cases, and 150 lost workdays.

**Industrial accidents – operations.** Alternative Group B direct operations staffing in the new waste processing facility would be the same as described for the modified T Plant Complex under Alternative Group A (see Section 5.11.1.1.3.3).

#### **5.11.1.2.3.5 Disposal – HSW Disposal Facilities**

Potential radiological and non-radiological (chemical) accidents and impacts for the HSW disposal facilities under Alternative Group B would be the same as for Alternative Group A. Industrial accidents are discussed below.

**Industrial accidents – construction.** Slightly more impacts would be expected for LLBG construction under Alternative Group B than under Alternative Group A and would require 54 to 83 worker-years. The estimated health and safety impacts would be 4 to 6 total recordable cases, 1 to 2 lost workday cases, and 24 to 41 lost workdays.

**Industrial accidents – operations.** Industrial accidents from LLBG operations would be the same as for Alternative Group A (see Section 5.11.1.1.3.4).

**ILAW industrial accidents.** Industrial accidents from ILAW trench construction, operations, and closure would be the same as for Alternative Group A (see Section 5.11.1.1.3.4).

#### **5.11.1.3 Alternative Group C**

Alternative Group C is similar to Alternative Group A except for the disposal location of some of the waste streams. See Section 5.0 for a summary of the characteristics for this alternative.

##### **5.11.1.3.1 Construction**

Primary impacts from construction activities would be air quality and injuries to construction workers. The construction activities would result in the emission of criteria pollutants, as identified in (40 CFR 50) from the use of combustion engines and earthmoving activities. Impacts are measured by comparison of air concentrations with regulatory limits at the point of maximum potential public exposure. The air quality analysis (Section 5.2) indicates that maximum emissions of all criteria pollutants (including sulfur dioxide, carbon monoxide, nitrogen dioxide, and PM<sub>10</sub>) from construction

activities would result in air concentrations below the regulatory limits. As a consequence, no impacts on public health from emissions would be expected. Impacts from industrial accidents during construction are discussed in Section 5.11.1.3.3.

### **5.11.1.3.2 Normal Operations**

Potential impacts to public health from normal operations include air quality impacts from atmospheric releases of radionuclides and chemicals from waste operations. Long-term impacts from releases to groundwater from LLBGs are discussed in Sections 5.11.2 and 5.3.

Alternative Group C involves operations that may result in routine releases of radionuclides and chemicals to the atmosphere and are the same operations as for Alternative Group A. These operations include waste package verification, treatment, and packaging at the WRAP; treatment and packaging of waste at the modified T Plant Complex; and treatment of leachate from MLLW trenches using pulse driers. The annual releases have been estimated for each year of operation for the facilities involved in this alternative. Details of the release calculations are presented in Volume II, Appendix F, Section F.1.

#### **5.11.1.3.2.1 Health Impacts from Routine Radionuclide Releases**

The expected doses and health impacts to non-involved workers and public from routine atmospheric releases of radionuclides are presented in Table 5.61 for the Hanford Only waste volume, Table 5.62 for the Lower Bound waste volume, and in Table 5.63 for the Upper Bound waste volume. The tables present the maximum annual dose to the non-involved workers and the MEI, the collective dose to public along with the probability of developing an LCF for the individual, and the number of LCFs expected for the public. Given that the cancer risk estimates and doses are small in comparison to regulatory limits,<sup>(a)</sup> no adverse health impacts would be expected from radionuclide releases.

#### **5.11.1.3.2.2 Health Impacts from Chemical Releases**

Releases of chemicals to the atmosphere could occur for the same processes involving release of radionuclides when wastes with hazardous chemicals are involved. The potential health impacts from chemical releases to the atmosphere for Alternative Group C are the same as for Alternative Group A, as presented in Table 5.36 for all waste volumes. The results are the same because the same processing and atmospheric releases occur for both alternative groups. Because all the peak hazard quotients are less than 1, and because the cancer risk estimates are small, no adverse health impacts would be expected from chemical releases.

#### **5.11.1.3.2.3 Worker Occupational Radiation Exposure**

The radiation dose received by workers involved with waste operations is estimated using historical exposure data for the facilities involved in the alternative, as provided in the Technical Information

---

(a) The maximum annual radiation dose presented in this section may be compared to the regulatory limit of 10 mrem/year (WAC 246-247; 40 CFR 61; DOE 1993).

**Table 5.61.** Non-Involved Worker and Public Health Impacts from Routine Atmospheric Releases of Radionuclides – Alternative Group C, Hanford Only Waste Volume

Exposed Group	Exposure Scenario <sup>(a)</sup>	Facility	Lifetime Dose <sup>(b)</sup> (mrem)	Probability of LCFs <sup>(c)</sup>	Maximum Annual Dose	
					Year	mrem
Worker Onsite (non-involved)	Industrial	WRAP	1.2E-03	7E-10	2004	1.3E-04
		Modified T Plant Complex	4.8E-01	3E-07	2003	3.9E-02
		Leachate Treatment <sup>(d,e)</sup>	5.8E-08	3E-14	2026	3.2E-09
MEI Offsite	Resident Gardener	WRAP	9.9E-05	6E-11	2004	1.1E-05
		Modified T Plant Complex	1.5E-03	9E-10	2003	1.1E-04
		Leachate Treatment	3.0E-11	2E-17	2026	1.6E-12
		Total	1.6E-03	1E-09	2003	1.2E-04
			<b>(person-rem)</b>	<b>Number of LCFs<sup>(f)</sup></b>	<b>Year</b>	<b>(person-rem)</b>
Population <sup>(g)</sup>	Population within 80 km (50 mi)	WRAP	9.1E-03	0 (5E-06)	2004	7.4E-04
		Modified T Plant Complex	1.4E-01	0 (8E-05)	2003	7.4E-03
		Leachate Treatment	2.7E-09	0 (2E-12)	2026	1.1E-10
		Total	1.5E-01	0 (9E-05)	2003	8.1E-03
<p>(a) The exposure duration for the industrial scenario is 20 years and for the resident gardener, 30 years. The exposure scenarios are described in Volume II, Appendix F.</p> <p>(b) The lifetime dose is the radiation dose received from intake during the exposure period and up to 50 years after exposure due to radionuclides deposited in the body during the exposure period.</p> <p>(c) LCF = latent cancer fatality.</p> <p>(d) Leachate treatment is a pulse drier operation.</p> <p>(e) If LLW trenches were to be lined, the doses from leachate collection and treatment might be as much as three times the leachate treatment values shown in this table.</p> <p>(f) The value in parentheses is the calculated value based on the population dose and the appropriate health effects conversion factor. The actual number of LCFs must be a whole number (deaths).</p> <p>(g) The population lifetime impacts are based on exposure for the same exposure pathways impacting the resident gardener MEI.</p>						

Document (FH 2004). The potential radiation exposure to workers for Alternative Group C are summarized in Table 5.64 for the Hanford Only waste volume, in Table 5.65 for the Lower Bound waste volume, and in Table 5.66 for the Upper Bound waste volume. The results are very similar to the Alternative Group A results except for pulse drier treatment of leachate. All estimated radiation doses to workers are well below regulatory limits.<sup>(a)</sup>

### 5.11.1.3.3 Accidents

Potential impacts of accidents under Alternative Group C would be identical to those described for Alternative Group A (see Section 5.11.1.1.3).

(a) The annual limit for occupational exposures is 5000 mrem/year (10 CFR 835).



**Table 5.62.** Non-Involved Worker and Public Health Impacts from Routine Atmospheric Releases of Radionuclides – Alternative Group C, Lower Bound Waste Volume

Exposed Group	Exposure Scenario <sup>(a)</sup>	Facility	Lifetime Dose <sup>(b)</sup> (mrem)	Probability of LCFs <sup>(c)</sup>	Maximum Annual Dose	
					Year	mrem
Worker Onsite (non-involved)	Industrial	WRAP	1.4E-03	9E-10	2004	1.6E-04
		Modified T Plant Complex	5.8E-01	3E-07	2003	4.8E-02
		Leachate Treatment <sup>(d,e)</sup>	6.0E-08	4E-14	2026	3.3E-09
MEI Offsite	Resident Gardener	WRAP	1.2E-04	7E-11	2004	1.3E-05
		Modified T Plant Complex	1.7E-03	1E-09	2003	1.2E-04
		Leachate Treatment	3.1E-11	2E-17	2026	1.6E-12
		Total	1.8E-03	1E-09	2003	1.3E-04
			<b>(person-rem)</b>	<b>Number of LCFs<sup>(f)</sup></b>	<b>Year</b>	<b>(person-rem)</b>
Population <sup>(g)</sup>	Population within 80 km (50 mi)	WRAP	1.1E-02	0 (6E-06)	2004	8.8E-04
		Modified T Plant Complex	1.6E-01	0 (9E-05)	2003	8.5E-03
		Leachate Treatment	2.8E-09	0 (2E-12)	2026	1.2E-10
		Total	1.7E-01	0 (1E-04)	2003	9.4E-03

(a) The exposure duration for the industrial scenario is 20 years and for the resident gardener, 30 years. The exposure scenarios are described in Volume II, Appendix F.

(b) The lifetime dose is the radiation dose received from intake during the exposure period and up to 50 years after exposure due to radionuclides deposited in the body during the exposure period.

(c) LCF = latent cancer fatality.

(d) Leachate treatment is a pulse drier operation.

(e) If LLW trenches were to be lined, the doses from leachate collection and treatment might be as much as three times the leachate treatment values shown in this table.

(f) The value in parentheses is the calculated value based on the population dose and the appropriate health effects conversion factor. The actual number of LCFs must be a whole number (deaths).

(g) The population lifetime impacts are based on exposure for the same exposure pathways impacting the resident gardener MEI.

#### 5.11.1.4 Alternative Group D

Alternative Group D is similar to Alternative Group A except for the disposal location of some of the waste streams. See Section 5 for a summary of the characteristics for the three subalternatives (D<sub>1</sub>, D<sub>2</sub>, and D<sub>3</sub>) to this alternative group.

##### 5.11.1.4.1 Construction

Primary impacts from construction activities would be air quality and injuries to construction workers. The construction activities would result in the emission of criteria pollutants (40 CFR 50) from the use of combustion engines and earthmoving activities. Impacts are measured by comparison of air concentrations with regulatory limits at the point of maximum potential public exposure. The air quality analysis (Section 5.2) indicates that maximum emissions of all criteria pollutants (including sulfur dioxide, carbon monoxide, nitrogen dioxide, and PM<sub>10</sub>) from construction activities would result in air

**Table 5.63.** Non-Involved Worker and Public Health Impacts from Routine Atmospheric Releases of Radionuclides – Alternative Group C, Upper Bound Waste Volume

Exposed Group	Exposure Scenario <sup>(a)</sup>	Facility	Lifetime Dose <sup>(b)</sup> (mrem)	Probability of LCFs <sup>(c)</sup>	Maximum Annual Dose	
					Year	mrem
Worker Onsite (non-involved)	Industrial	WRAP	2.2E-03	1E-09	2004	1.9E-04
		Modified T Plant Complex	8.9E-01	5E-07	2006	7.2E-02
		Leachate Treatment <sup>(d,e)</sup>	1.2E-07	7E-14	2026	6.7E-09
MEI Offsite	Resident Gardener	WRAP	2.1E-04	1E-10	2004	1.6E-05
		Modified T Plant Complex	2.3E-03	1E-09	2006	1.7E-04
		Leachate Treatment	6.2E-11	4E-17	2026	3.3E-12
		Total	2.5E-03	1E-09	2006	1.9E-04
			(person-rem)	Number of LCFs <sup>(f)</sup>	Year	(person-rem)
Population <sup>(g)</sup>	Population within 80 km (50 mi)	WRAP	1.9E-02	0 (1E-05)	2004	1.1E-03
		Modified T Plant Complex	2.2E-01	0 (1E-04)	2006	1.5E-02
		Leachate Treatment	5.6E-09	0 (3E-12)	2026	2.3E-10
		Total	2.4E-01	0 (1E-04)	2006	1.6E-02
<p>(a) The exposure duration for the industrial scenario is 20 years and for the resident gardener, 30 years. The exposure scenarios are described in Volume II, Appendix F.</p> <p>(b) The lifetime dose is the radiation dose received from intake during the exposure period and up to 50 years after exposure due to radionuclides deposited in the body during the exposure period.</p> <p>(c) LCF = latent cancer fatality.</p> <p>(d) Leachate treatment is a pulse drier operation.</p> <p>(e) If LLW trenches were to be lined, the doses from leachate collection and treatment might be as much as three times the leachate treatment values shown in this table.</p> <p>(f) The value in parentheses is the calculated value based on the population dose and the appropriate health effects conversion factor. The actual number of LCFs must be a whole number (deaths).</p> <p>(g) The population lifetime impacts are based on exposure for the same exposure pathways impacting the resident gardener MEI.</p>						

concentrations below the regulatory limits. As a consequence, no impacts on public health from emissions would be expected. Impacts from industrial accidents during construction are discussed in Section 5.11.1.4.3.

#### 5.11.1.4.2 Normal Operations

Potential impacts to public health from normal operations include air quality impacts from atmospheric releases of radionuclides and chemicals from waste operations. Long-term impacts from releases to groundwater from LLBGs are discussed in Sections 5.11.2 and 5.3.

Alternative Group D involves operations that may result in routine releases of radionuclides and chemicals to the atmosphere and are the same as operations for Alternative Group A. These operations include waste package verification, treatment, and packaging at the WRAP; treatment and packaging of waste at the modified T Plant Complex; and treatment of leachate from MLLW trenches using pulse

**Table 5.64.** Occupational Radiation Exposure – Alternative Group C, Hanford Only Waste Volume

Facility	Operating Period	Worker Category <sup>(a)</sup>	Workers (FTE) <sup>(b)</sup>	Average Dose Rate (mrem/yr)	Workforce Dose (person-rem)	Workforce LCF <sup>(c)</sup>
LLW and MLLW Trenches	2002–2046	Operator	14	54	34	0 (2E-02)
		RCT	4	45	8.5	0 (5E-03)
		Other	66	35	104	0 (6E-02)
ILAW	2008–2028	Workers	70	300 <sup>(e)</sup>	443	0 (3E-01)
	2032–2046	Workers	20	14	4.1	0 (2E-03)
CWC	2002–2046	Operator	12	54	29	0 (1E-02)
		RCT	4	45	8.6	0 (5E-03)
		Other	55	17	42	0 (3E-02)
WRAP	2002–2032	Operator	13	18	7.3	0 (4E-03)
		RCT	9	36	10	0 (6E-03)
		Other	29	13	12	0 (7E-03)
	2033–2039	Operator	9	18	1.2	0 (7E-04)
		RCT	6	36	1.6	0 (1E-03)
		Other	21	13	1.9	0 (1E-03)
Modified T Plant Complex	2002–2032	Operator	20	9	5.6	0 (3E-03)
		RCT	18	13	7.3	0 (4E-03)
		Other	38	7	8.2	0 (5E-03)
	2033–2046	Operator	14	9	1.7	0 (1E-03)
		RCT	13	13	2.3	0 (1E-03)
		Other	27	7	2.6	0 (2E-03)
	2013–2031	Operator	10	13	2.6	0 (2E-03)
		RCT	10	13	2.4	0 (1E-03)
		Other	20	13	4.9	0 (3E-03)
Generator Staff <sup>(f)</sup>	2002–2019	Operator	15	34	9.2	0 (6E-03)
		RCT	12	35	8	0 (5E-03)
	2020–2026	Operator	5	34	1.2	0 (7E-04)
		RCT	3	35	0.7	0 (4E-04)
	2027–2044	Operator	1	34	0.6	0 (4E-04)
		RCT	1	35	0.6	0 (4E-04)
Pulse Driers	2026–2077	Operator <sup>(d)</sup>	0.4	54	1.1	0 (7E-04)
<b>Total</b>					<b>765</b>	<b>0 (5E-01)</b>
<p>(a) RCT = radiation control technician.</p> <p>(b) The number of workers is the average necessary for the facility during the indicated period.</p> <p>(c) LCF = latent cancer fatality. Workforce LCFs are the inferred number of cancer deaths in the exposed workforce, which must be a whole number (deaths). The value in parentheses is the calculated value based on the workforce dose and the appropriate health effects conversion factor.</p> <p>(d) Operators are provided by contract with the vendor operating the pulse drier unit. Radiological monitoring (RCT) resources are included with the RCT resources for LLW/MLLW trenches.</p> <p>(e) The dose rates for placement of ILAW into disposal facilities are higher than for other solid waste management operations because the material emits more radiation.</p> <p>(f) Staff in the solid waste support services group that work as needed in various solid waste facilities.</p>						

**Table 5.65.** Occupational Radiation Exposure – Alternative Group C, Lower Bound Waste Volume

Facility	Operating Period	Worker Category <sup>(a)</sup>	Workers (FTE) <sup>(b)</sup>	Average Dose Rate (mrem/yr)	Workforce Dose (person-rem)	Workforce LCF <sup>(c)</sup>
LLW and MLLW Trenches	2002–2046	Operator	14	54	34	0 (2E-02)
		RCT	4	45	8.5	0 (5E-03)
		Other	66	35	104	0 (6E-02)
ILAW	2008–2028	Workers	70	300 <sup>(e)</sup>	443	0 (3E-01)
	2032–2046	Workers	20	14	4.1	0 (2E-03)
CWC	2002–2046	Operator	12	54	29	0 (2E-02)
		RCT	4	45	8.6	0 (5E-03)
		Other	55	17	42	0 (3E-02)
WRAP	2002–2032	Operator	13	18	7.3	0 (4E-03)
		RCT	9	36	10	0 (6E-03)
		Other	29	13	12	0 (7E-03)
	2033–2039	Operator	9	18	1.2	0 (7E-04)
		RCT	6	36	1.6	0 (1E-03)
		Other	21	13	1.9	0 (1E-03)
Modified T Plant Complex	2002–2032	Operator	20	9	5.6	0 (3E-03)
		RCT	18	13	7.3	0 (4E-03)
		Other	38	7	8.2	0 (5E-03)
	2033–2046	Operator	14	9	1.7	0 (1E-03)
		RCT	13	13	2.3	0 (1E-03)
		Other	27	7	2.6	0 (2E-03)
	2013–2031	Operator	10	13	2.6	0 (2E-03)
		RCT	10	13	2.4	0 (1E-03)
		Other	20	13	4.9	0 (3E-03)
Generator Staff <sup>(f)</sup>	2002–2019	Operator	15	34	9.2	0 (6E-03)
		RCT	12	35	8	0 (5E-03)
	2020–2026	Operator	5	34	1.2	0 (7E-04)
		RCT	3	35	0.7	0 (4E-04)
	2027–2044	Operator	1	34	0.6	0 (4E-04)
		RCT	1	35	0.6	0 (4E-04)
Pulse Driers	2026–2077	Operator <sup>(d)</sup>	0.4	54	1.1	0 (7E-04)
<b>Total</b>					<b>765</b>	<b>0 (5E-01)</b>
<p>(a) RCT = radiation control technician.</p> <p>(b) The number of workers is the average necessary for the facility during the indicated period.</p> <p>(c) LCF = latent cancer fatality. Workforce LCFs are the inferred number of cancer deaths in the exposed workforce, which must be a whole number (deaths). The value in parentheses is the calculated value based on the workforce dose and the appropriate health effects conversion factor.</p> <p>(d) Operators are provided by contract with the vendor operating the pulse drier unit. Radiological monitoring (RCT) resources are included with the RCT resources for LLW/MLLW trenches.</p> <p>(e) The dose rates for placement of ILAW into disposal facilities are higher than for other solid waste management operations because the material emits more radiation.</p> <p>(f) Staff in the solid waste support services group that work as needed in various solid waste facilities.</p>						

**Table 5.66.** Occupational Radiation Exposure – Alternative Group C, Upper Bound Waste Volume

Facility	Operating Period	Worker Category <sup>(a)</sup>	Workers (FTE) <sup>(b)</sup>	Average Dose Rate (mrem/yr)	Workforce Dose (person-rem)	Workforce LCF <sup>(c)</sup>
LLW and MLLW Trenches	2002–2046	Operator	14	54	34	0 (2E-02)
		RCT	4	45	8.5	0 (5E-03)
		Other	66	35	104	0 (6E-02)
ILAW	2008–2028	Workers	70	300 <sup>(e)</sup>	443	0 (3E-01)
	2032–2046	Workers	20	14	4.1	0 (2E-03)
CWC	2002–2046	Operator	12	54	29	0 (2E-02)
		RCT	4	45	8.6	0 (5E-03)
		Other	55	17	42	0 (3E-02)
WRAP	2002–2032	Operator	13	18	7.3	0 (4E-03)
		RCT	9	36	10	0 (6E-03)
		Other	29	13	12	0 (7E-03)
	2033–2039	Operator	9	18	1.2	0 (7E-04)
		RCT	6	36	1.6	0 (1E-03)
		Other	32	13	1.9	0 (1E-03)
Modified T Plant Complex	2002–2032	Operator	20	9	5.5	0 (3E-03)
		RCT	18	13	7.4	0 (4E-03)
		Other	38	7	8.2	0 (5E-03)
	2033–2046	Operator	14	9	1.7	0 (1E-03)
		RCT	13	13	2.3	0 (1E-03)
		Other	27	7	2.6	0 (2E-03)
	2013–2031	Operator	10	13	2.6	0 (2E-03)
		RCT	10	13	2.4	0 (1E-03)
		Other	20	13	4.9	0 (3E-03)
Generator Staff <sup>(f)</sup>	2002–2019	Operator	20	34	12	0 (7E-03)
		RCT	13	35	8.2	0 (5E-03)
	2020–2026	Operator	7	34	1.7	0 (1E-03)
		RCT	5	35	1.2	0 (7E-04)
	2027–2044	Operator	3	34	1.8	0 (1E-03)
		RCT	2	35	1.3	0 (8E-04)
Pulse Driers	2026–2077	Operators <sup>(d)</sup>	0.8	54	2.2	0 (1E-03)
<b>Total</b>					<b>773</b>	<b>0 (5E-01)</b>
<p>(a) RCT = radiation control technician.</p> <p>(b) The number of workers is the average necessary for the facility during the indicated period.</p> <p>(c) LCF = latent cancer fatality. Workforce LCFs are the inferred number of cancer deaths in the exposed workforce, which must be a whole number (deaths). The value in parentheses is the calculated value based on the workforce dose and the appropriate health effects conversion factor.</p> <p>(d) Operators are provided by contract with the vendor operating the pulse drier unit. Radiological monitoring (RCT) resources are included with the RCT resources for LLW/MLLW trenches.</p> <p>(e) The dose rates for placement of ILAW into disposal facilities are higher than for other solid waste management operations because the material emits more radiation.</p> <p>(f) Staff in the solid waste support services group that work as needed in various solid waste facilities.</p>						

driers. The annual releases have been estimated for each year of operation for the facilities involved in this alternative. Details of the release calculations are presented in Volume II, Appendix F, Section F.1.

#### 5.11.1.4.2.1 Health Impacts from Routine Radionuclide Releases

The expected doses and health impacts to non-involved workers and public from routine atmospheric releases of radionuclides are presented in Table 5.67 for the Hanford Only waste volume, Table 5.68 for the Lower Bound waste volume, and in Table 5.69 for the Upper Bound waste volume. The tables present the maximum annual dose to the non-involved workers and the MEI, and the collective dose to the public along with the probability of developing an LCF for the individual and the number of LCFs expected for the public. Given that the cancer risk estimates and doses are small in comparison to regulatory limits,<sup>(a)</sup> no adverse health impacts would be expected from radionuclide releases.

**Table 5.67.** Non-Involved Worker and Public Health Impacts from Routine Atmospheric Releases of Radionuclides – Alternative Group D, Hanford Only Waste Volume

Exposed Group	Exposure Scenario <sup>(a)</sup>	Facility	Lifetime Dose <sup>(b)</sup> (mrem)	Probability of LCFs <sup>(c)</sup>	Maximum Annual Dose	
					Year	mrem
Worker Onsite (non-involved)	Industrial	WRAP	1.2E-03	7E-10	2004	1.3E-04
		Modified T Plant Complex	4.8E-01	3E-07	2003	3.9E-02
		Leachate Treatment <sup>(d,e)</sup>	1.5E-07	9E-14	2026	8.2E-09
MEI Offsite	Resident Gardener	WRAP	9.9E-05	6E-11	2004	1.1E-05
		Modified T Plant Complex	1.5E-03	9E-10	2003	1.1E-04
		Leachate Treatment	7.6E-11	5E-17	2026	4.0E-12
		Total	1.6E-03	1E-09	2003	1.2E-04
			<b>(person-rem)</b>	<b>Number of LCFs<sup>(f)</sup></b>	<b>Year</b>	<b>(person-rem)</b>
Population <sup>(g)</sup>	Population within 80 km (50 mi)	WRAP	9.1E-03	0 (5E-06)	2004	7.4E-04
		Modified T Plant Complex	1.4E-01	0 (8E-05)	2003	7.4E-03
		Leachate Treatment	6.9E-09	0 (4E-12)	2026	2.8E-10
		Total	1.5E-01	0 (9E-05)	2003	8.1E-03

(a) The exposure duration for the industrial scenario is 20 years and for the resident gardener, 30 years. The exposure scenarios are described in Volume II, Appendix F.

(b) The lifetime dose is the radiation dose received from intake during the exposure period and up to 50 years after exposure due to radionuclides deposited in the body during the exposure period.

(c) LCF = latent cancer fatality.

(d) Leachate treatment is a pulse drier operation.

(e) If LLW trenches were to be lined, the doses from leachate collection and treatment might be as much as three times the leachate treatment values shown in this table.

(f) The value in parentheses is the calculated value based on the population dose and the appropriate health effects conversion factor. The actual number of LCFs must be a whole number (deaths).

(g) The population lifetime impacts are based on exposure for the same exposure pathways impacting the resident gardener MEI.

(a) The maximum annual radiation dose presented in this section may be compared to the regulatory limit of 10 mrem/year (WAC 246-247; 40 CFR 61; DOE 1993).

**Table 5.68.** Non-Involved Worker and Public Health Impacts from Routine Atmospheric Releases of Radionuclides – Alternative Group D, Lower Bound Waste Volume

Exposed Group	Exposure Scenario <sup>(a)</sup>	Facility	Lifetime Dose <sup>(b)</sup> (mrem)	Probability of LCFs <sup>(c)</sup>	Maximum Annual Dose	
					Year	mrem
Worker Onsite (non-involved)	Industrial	WRAP	1.4E-03	9E-10	2004	1.6E-04
		Modified T Plant Complex	5.8E-01	3E-07	2003	4.8E-02
		Leachate Treatment <sup>(d,e)</sup>	1.7E-07	1E-13	2026	9.1E-09
MEI Offsite	Resident Gardener	WRAP	1.2E-04	7E-11	2004	1.3E-05
		Modified T Plant Complex	1.7E-03	1E-09	2003	1.2E-04
		Leachate Treatment	8.5E-11	5E-17	2026	4.5E-12
		Total	1.8E-03	1E-09	2003	1.3E-04
			<b>(person-rem)</b>	<b>Number of LCFs<sup>(f)</sup></b>	<b>Year</b>	<b>(person-rem)</b>
Population <sup>(g)</sup>	Population within 80 km (50 mi)	WRAP	1.1E-02	0 (6E-06)	2004	8.8E-04
		Modified T Plant Complex	1.6E-01	0 (9E-05)	2003	8.5E-03
		Leachate Treatment	7.7E-09	0 (5E-12)	2026	3.2E-10
		Total	1.7E-01	0 (1E-04)	2003	9.4E-03
<p>(a) The exposure duration for the industrial scenario is 20 years and for the resident gardener, 30 years. The exposure scenarios are described in Volume II, Appendix F.</p> <p>(b) The lifetime dose is the radiation dose received from intake during the exposure period and up to 50 years after exposure due to radionuclides deposited in the body during the exposure period.</p> <p>(c) LCF = latent cancer fatality.</p> <p>(d) Leachate treatment is a pulse drier operation.</p> <p>(e) If LLW trenches were to be lined, the doses from leachate collection and treatment might be as much as three times the leachate treatment values shown in this table.</p> <p>(f) The value in parentheses is the calculated value based on the population dose and the appropriate health effects conversion factor. The actual number of LCFs must be a whole number (deaths).</p> <p>(g) The population lifetime impacts are based on exposure for the same exposure pathways impacting the resident gardener MEI.</p>						

**Table 5.69.** Non-Involved Worker and Public Health Impacts from Routine Atmospheric Releases of Radionuclides – Alternative Group D, Upper Bound Waste Volume

Exposed Group	Exposure Scenario <sup>(a)</sup>	Facility	Lifetime Dose <sup>(b)</sup> (mrem)	Probability of LCFs <sup>(c)</sup>	Maximum Annual Dose	
					Year	mrem
Worker Onsite (non-involved)	Industrial	WRAP	2.2E-03	1E-09	2004	1.9E-04
		Modified T Plant Complex	8.9E-01	5E-07	2006	7.2E-02
		Leachate Treatment <sup>(d,e)</sup>	3.7E-07	2E-13	2026	2.1E-09
MEI Offsite	Resident Gardener	WRAP	2.1E-04	1E-10	2004	1.6E-05
		Modified T Plant Complex	2.3E-03	1E-09	2006	1.7E-04
		Leachate Treatment	1.9E-10	1E-16	2026	1.0E-11
		Total	2.5E-03	1E-09	2006	1.9E-04
			(person-rem)	Number of LCFs <sup>(f)</sup>	Year	(person-rem)
Population <sup>(g)</sup>	Population within 80 km (50 mi)	WRAP	1.9E-02	0 (1E-05)	2004	1.1E-03
		Modified T Plant Complex	2.2E-01	0 (1E-04)	2006	1.5E-02
		Leachate Treatment	1.7E-08	0 (1E-11)	2026	7.1E-10
		Total	2.4E-01	0 (1E-04)	2006	1.6E-02
<p>(a) The exposure duration for the industrial scenario is 20 years and for the resident gardener, 30 years. The exposure scenarios are described in Volume II, Appendix F.</p> <p>(b) The lifetime dose is the radiation dose received from intake during the exposure period and up to 50 years after exposure due to radionuclides deposited in the body during the exposure period.</p> <p>(c) LCF = latent cancer fatality.</p> <p>(d) Leachate treatment is a pulse drier operation.</p> <p>(e) If LLW trenches were to be lined, the doses from leachate collection and treatment might be as much as three times the leachate treatment values shown in this table.</p> <p>(f) The value in parentheses is the calculated value based on the population dose and the appropriate health effects conversion factor. The actual number of LCFs must be a whole number (deaths).</p> <p>(g) The population lifetime impacts are based on exposure for the same exposure pathways impacting the resident gardener MEI.</p>						

#### 5.11.1.4.2.2 Health Impacts from Chemical Releases

Releases of chemicals to the atmosphere could occur for the same processes involving release of radionuclides when wastes with hazardous chemicals are involved. The potential health impacts from chemical releases to the atmosphere for Alternative Group D are the same as for Alternative Group A, as presented in Table 5.25 for all waste volumes. The results are the same because the same processing and atmospheric releases occur for both alternative groups. Because all the peak hazard quotients are less than 1, and because the cancer risk estimates are small, no adverse health impacts would be expected from chemical releases.

#### 5.11.1.4.2.3 Worker Occupational Radiation Exposure

The radiation dose received by workers involved with waste operations is estimated using historical exposure data for the facilities involved in the alternative, as provided in the Technical Information Document (FH 2004). The potential radiation exposure to workers for Alternative Group D are summarized in Table 5.70 for the Hanford Only waste volume, in Table 5.71 for the Lower Bound waste



volume, and in Table 5.72 for the Upper Bound waste volume. The results are very similar to the Alternative Group A results except for pulse drier treatment of leachate. All estimated radiation doses to workers are well below regulatory limits.<sup>(a)</sup>

#### **5.11.1.4.3 Accidents**

Potential impacts of accidents under Alternative Group D would be identical to those described for Alternative Group A (see Section 5.11.1.1.3).

#### **5.11.1.5 Alternative Group E**

Alternative Group E is similar to Alternative Groups A and D except for the disposal location of some of the waste streams. See Section 5 for a summary of the characteristics for the three subalternatives (E<sub>1</sub>, E<sub>2</sub>, and E<sub>3</sub>) to this alternative group.

##### **5.11.1.5.1 Construction**

Primary impacts from construction activities would be air quality and injuries to construction workers. The construction activities would result in the emission of criteria pollutants (40 CFR 50) from the use of combustion engines and earthmoving activities. Impacts are measured by comparison of air concentrations with regulatory limits at the point of maximum potential public exposure. The air quality analysis (Section 5.2) indicates that maximum emissions of all criteria pollutants (including sulfur dioxide, carbon monoxide, nitrogen dioxide, and PM<sub>10</sub>) from construction activities would result in air concentrations below the regulatory limits. As a consequence, no impacts on public health from emissions would be expected. Impacts from industrial accidents during construction are discussed in Section 5.11.1.5.3.

##### **5.11.1.5.2 Normal Operations**

Potential impacts to public health from normal operations include air quality impacts from atmospheric releases of radionuclides and chemicals from waste operations. Long-term impacts from releases to groundwater from LLBGs are discussed in Sections 5.11.2 and 5.3.

Alternative Group E involves operations that may result in routine releases of radionuclides and chemicals to the atmosphere and are the same operations as for Alternative Group A. These operations include waste package verification, treatment, and packaging at the WRAP; treatment and packaging of waste at the modified T Plant Complex; and treatment of leachate from MLLW trenches using pulse driers. The annual releases have been estimated for each year of operation for the facilities involved in this alternative. Details of the release calculations are presented in Volume II, Appendix F, Section F.1.

---

(a) The annual limit for occupational exposures is 5000 mrem/year (10 CFR 835).

**Table 5.70.** Occupational Radiation Exposure – Alternative Group D, Hanford Only Waste Volume

Facility	Operating Period	Worker Category <sup>(a)</sup>	Workers (FTE) <sup>(b)</sup>	Average Dose Rate, (mrem/yr)	Workforce Dose (person-rem)	Workforce LCF <sup>(c)</sup>
LLW and MLLW Trenches	2002–2046	Operator	14	54	34	0 (2E-02)
		RCT	4	45	8.5	0 (5E-03)
		Other	66	35	104	0 (6E-02)
ILAW	2008–2028	Workers	70	300 <sup>(e)</sup>	443	0 (3E-01)
	2032–2046	Workers	20	14	4.1	0 (2E-03)
CWC	2002–2046	Operator	12	54	29	0 (2E-02)
		RCT	4	45	8.6	0 (5E-03)
		Other	55	17	42	0 (3E-02)
WRAP	2002–2032	Operator	13	18	7.3	0 (4E-03)
		RCT	9	36	10	0 (6E-03)
		Other	29	13	12	0 (7E-03)
	2033–2039	Operator	9	18	1.2	0 (7E-04)
		RCT	6	36	1.6	0 (1E-03)
		Other	21	13	1.9	0 (1E-03)
Modified T Plant Complex	2002–2032	Operator	20	9	5.6	0 (3E-03)
		RCT	18	13	7.3	0 (4E-03)
		Other	38	7	8.2	0 (5E-03)
	2033–2046	Operator	14	9	1.7	0 (1E-03)
		RCT	13	13	2.3	0 (1E-03)
		Other	27	7	2.6	0 (2E-03)
	2013–2031	Operator	10	13	2.6	0 (2E-03)
		RCT	10	13	2.4	0 (1E-03)
		Other	20	13	4.9	0 (3E-03)
Generator Staff <sup>(f)</sup>	2002–2019	Operator	15	34	9.2	0 (6E-03)
		RCT	12	35	8	0 (5E-03)
	2020–2026	Operator	5	34	1.2	0 (7E-04)
		RCT	3	35	0.7	0 (4E-04)
	2027–2044	Operator	1	34	0.6	0 (4E-04)
		RCT	1	35	0.6	0 (4E-04)
Pulse Driers	2026–2077	Operator <sup>(d)</sup>	1.0	54	2.8	0 (2E-03)
<b>Total</b>					<b>767</b>	<b>0 (4.6E-01)</b>

- (a) RCT = radiation control technician.  
 (b) The number of workers is the average necessary for the facility during the indicated period.  
 (c) LCF = latent cancer fatality. Workforce LCFs are the inferred number of cancer deaths in the exposed workforce, which must be a whole number (deaths). The value in parentheses is the calculated value based on the workforce dose and the appropriate health effects conversion factor.  
 (d) Operators are provided by contract with the vendor operating the pulse drier unit. Radiological monitoring (RCT) resources are included with the RCT resources for LLW/MLLW trenches.  
 (e) The dose rates for placement of ILAW into disposal facilities are higher than for other solid waste management operations because the material emits more radiation.  
 (f) Staff in the solid waste support services group that work as needed in various solid waste facilities.

**Table 5.71.** Occupational Radiation Exposure – Alternative Group D, Lower Bound Waste Volume

Facility	Operating Period	Worker Category <sup>(a)</sup>	Workers (FTE) <sup>(b)</sup>	Average Dose Rate (mrem/yr)	Workforce Dose (person-rem)	Workforce LCF <sup>(c)</sup>
LLW and MLLW Trenches	2002–2046	Operator	14	54	34	0 (2E-02)
		RCT	4	45	8.5	0 (5E-03)
		Other	66	35	104	0 (6E-02)
ILAW	2008–2028	Workers	70	300 <sup>(e)</sup>	443	0 (3E-01)
	2032–2046	Workers	20	14	4.1	0 (2E-03)
CWC	2002–2046	Operator	12	54	29	0 (2E-02)
		RCT	4	45	8.6	0 (5E-03)
		Other	55	17	42	0 (3E-02)
WRAP	2002–2032	Operator	13	18	7.3	0 (4E-03)
		RCT	9	36	10	0 (6E-03)
		Other	29	13	12	0 (7E-03)
	2033–2039	Operator	9	18	1.2	0 (7E-04)
		RCT	6	36	1.6	0 (1E-03)
		Other	21	13	1.9	0 (1E-03)
Modified T Plant Complex	2002–2032	Operator	20	9	5.6	0 (3E-03)
		RCT	18	13	7.3	0 (4E-03)
		Other	38	7	8.2	0 (5E-03)
	2033–2046	Operator	14	9	1.7	0 (1E-03)
		RCT	13	13	2.3	0 (1E-03)
		Other	27	7	2.6	0 (2E-03)
	2013–2031	Operator	10	13	2.6	0 (2E-03)
		RCT	10	13	2.4	0 (1E-03)
		Other	20	13	4.9	0 (3E-03)
Generator Staff <sup>(f)</sup>	2002–2019	Operator	15	34	9.2	0 (6E-03)
		RCT	12	35	8	0 (5E-03)
	2020–2026	Operator	5	34	1.2	0 (7E-04)
		RCT	3	35	0.7	0 (4E-04)
	2027–2044	Operator	1	34	0.6	0 (4E-04)
		RCT	1	35	0.6	0 (4E-04)
Pulse Driers	2026–2077	Operator <sup>(d)</sup>	1.1	54	3.1	0 (2E-03)
<b>Total</b>					<b>767</b>	<b>0 (4.6E-01)</b>

(a) RCT = radiation control technician.

(b) The number of workers is the average necessary for the facility during the indicated period.

(c) LCF = latent cancer fatality. Workforce LCFs are the inferred number of cancer deaths in the exposed workforce, which must be a whole number (deaths). The value in parentheses is the calculated value based on the workforce dose and the appropriate health effects conversion factor.

(d) Operators are provided by contract with the vendor operating the pulse drier unit. Radiological monitoring (RCT) resources are included with the RCT resources for LLW/MLLW trenches.

(e) The dose rates for placement of ILAW into disposal facilities are higher than for other solid waste management operations because the material emits more radiation.

(f) Staff in the solid waste support services group that work as needed in various solid waste facilities.

**Table 5.72.** Occupational Radiation Exposure – Alternative Group D, Upper Bound Waste Volume

Facility	Operating Period	Worker Category <sup>(a)</sup>	Workers (FTE) <sup>(b)</sup>	Average Dose Rate (mrem/yr)	Workforce Dose (person-rem)	Workforce LCF <sup>(c)</sup>
LLW and MLLW Trenches	2002–2046	Operator	14	54	34	0 (2E-02)
		RCT	4	45	8.5	0 (5E-03)
		Other	66	35	104	0 (6E-02)
ILAW	2008–2028	Workers	70	300 <sup>(e)</sup>	443	0 (3E-01)
	2032–2046	Workers	20	14	4.1	0 (2E-03)
CWC	2002–2046	Operator	12	54	29	0 (2E-02)
		RCT	4	45	8.6	0 (5E-03)
		Other	55	17	42	0 (3E-02)
WRAP	2002–2032	Operator	13	18	7.3	0 (4E-03)
		RCT	9	36	10	0 (6E-03)
		Other	29	13	12	0 (7E-03)
	2033–2039	Operator	9	18	1.2	0 (7E-04)
		RCT	6	36	1.6	0 (1E-03)
		Other	32	13	1.9	0 (1E-03)
Modified T Plant Complex	2002–2032	Operator	20	9	5.5	0 (3E-03)
		RCT	18	13	7.4	0 (4E-03)
		Other	38	7	8.2	0 (5E-03)
	2033–2046	Operator	14	9	1.7	0 (1E-03)
		RCT	13	13	2.3	0 (1E-03)
		Other	27	7	2.6	0 (2E-03)
	2013–2031	Operator	10	13	2.6	0 (2E-03)
		RCT	10	13	2.4	0 (1E-03)
		Other	20	13	4.9	0 (3E-03)
Generator Staff <sup>(f)</sup>	2002–2019	Operator	20	34	12	0 (7E-03)
		RCT	13	35	8.2	0 (5E-03)
	2020–2026	Operator	7	34	1.7	0 (1E-03)
		RCT	5	35	1.2	0 (7E-04)
	2027–2044	Operator	3	34	1.8	0 (1E-03)
		RCT	2	35	1.3	0 (8E-04)
Pulse Driers	2026–2077	Operators <sup>(d)</sup>	2.5	54	6.9	0 (4E-03)
<b>Total</b>					<b>778</b>	<b>0 (4.7E-01)</b>
<p>(a) RCT = radiation control technician.</p> <p>(b) The number of workers is the average necessary for the facility during the indicated period.</p> <p>(c) LCF = latent cancer fatality. Workforce LCFs are the inferred number of cancer deaths in the exposed workforce, which must be a whole number (deaths). The value in parentheses is the calculated value based on the workforce dose and the appropriate health effects conversion factor.</p> <p>(d) Operators are provided by contract with the vendor operating the pulse drier unit. Radiological monitoring (RCT) resources are included with the RCT resources for LLW/MLLW trenches.</p> <p>(e) The dose rates for placement of ILAW into disposal facilities are higher than for other solid waste management operations because the material emits more radiation.</p> <p>(f) Staff in the solid waste support services group that work as needed in various solid waste facilities.</p>						

#### **5.11.1.5.2.1 Health Impacts from Routine Radionuclide Releases**

The expected doses and health impacts to non-involved workers and public from routine atmospheric releases of radionuclides for the Alternative Group E cases are the same as those for Alternative Group D, as presented in Table 5.67 for the Hanford Only waste volume, Table 5.68 for the Lower Bound waste volume, and in Table 5.69 for the Upper Bound waste volume. The tables present the maximum annual dose to the non-involved workers and the MEI, and the collective dose to public along with the probability of developing an LCF for the individual and the number of LCFs expected for the public. Given that the cancer risk estimates and doses are small in comparison to regulatory limits,<sup>(a)</sup> no adverse health impacts would be expected from radionuclide releases.

#### **5.11.1.5.2.2 Health Impacts from Chemical Releases**

Releases of chemicals to the atmosphere could occur for the same processes involving release of radionuclides when wastes with hazardous chemicals are involved. The potential health impacts from chemical releases to the atmosphere for Alternative Group E are the same as for Alternative Group A, as presented in Table 5.25 for all waste volumes. The results are the same because the same processing and atmospheric releases occur for both alternative groups. Because all the peak hazard quotients are less than 1, and because the cancer risk estimates are small, no adverse health impacts would be expected from chemical releases.

#### **5.11.1.5.2.3 Worker Occupational Radiation Exposure**

The radiation dose received by workers involved with waste operations is estimated using historical exposure data for the facilities involved in the alternative, as provided in the Technical Information Document (FH 2004). The potential radiation exposure to workers for Alternative Group E are the same as those for Alternative Group D as summarized in Table 5.70 for the Hanford Only waste volume, in Table 5.71 for the Lower Bound waste volume, and in Table 5.72 for the Upper Bound waste volume. All estimated radiation doses to workers are well below regulatory limits.<sup>(b)</sup>

#### **5.11.1.5.3 Accidents**

The potential impacts of accidents under Alternative Group E would be identical to those described for Alternative Group A (see Section 5.11.1.1.3).

#### **5.11.1.6 No Action Alternative**

Under the No Action Alternative, DOE would continue operation of the waste management facilities and activities that are ongoing at the Hanford Site. Additional storage facilities would be constructed as needed, but no new treatment facilities would be constructed. DOE would continue operation of the WRAP and the modified T Plant Complex. The commercial contracts for thermal treatment and stabilization would be used only at their minimum levels, and the other wastes would remain in storage.

---

(a) The maximum annual radiation dose presented in this section may be compared to the regulatory limit of 10 mrem/year (WAC 246-247; 40 CFR 61; DOE 1993).

(b) The annual limit for occupational exposures is 5000 mrem/year (10 CFR 835).

With the No Action Alternative, disposal of LLW and MLLW would continue in existing trenches in the LLBGs. New trenches for LLW would be constructed using the current design. When existing MLLW trenches are full, additional MLLW would be stored in an expanded CWC. Only certified TRU waste would be sent to the WIPP. The No Action Alternative provides for continued storage of the wastes through 2046.

#### **5.11.1.6.1 Construction**

As part of the No Action Alternative, new construction activities are anticipated at the CWC and the HSW disposal facilities. Additional storage facilities would be constructed at the CWC to meet the needs for expected volumes of TRU waste, continued generation of RH-MLLW, non-standard containers of MLLW, and CH-MLLW. Under this alternative, DOE would continue to dispose of LLW using the existing trenches and new trenches within the HSW disposal facilities.

The primary impacts from construction activities would be to air quality and injury of construction workers. No impacts to construction workers are expected from radiation or chemicals because new construction activities would be performed away from areas of known contamination. Impacts to non-involved workers (from other onsite activities) are expected to bound potential air quality impacts to construction workers. Impacts from industrial accidents during construction are discussed in Section 5.11.1.6.3.

The construction activities would result in the emission of criteria pollutants (40 CFR 50) from the use of combustion engines and earth moving activities. Impacts are measured by comparison of air concentrations at the point of maximum potential public exposure. The air quality analysis (Section 5.2) indicated that all emissions of criteria pollutants (including sulfur oxides, carbon monoxide, nitrogen oxides, and PM<sub>10</sub>) from construction activities result in air concentrations below regulatory limits. As a consequence, no health impacts would be expected from these emissions.

#### **5.11.1.6.2 Normal Operations**

Potential impacts to public health from normal operations include air quality impacts from atmospheric releases of radionuclides and chemicals from waste operations. Long-term impacts from releases to groundwater from LLBGs are discussed in Sections 5.11.2 and 5.3.

The No Action Alternative involves operations that may result in routine releases of radionuclides and chemicals to the atmosphere. These operations include waste package verification, treatment, and packaging at the WRAP; processing of materials and equipment at the modified T Plant Complex; and treatment of leachate from MLLW trenches using pulse driers. The annual releases have been estimated for each year of operation for the facilities involved in the No Action Alternative. Details of the release calculations are described in Volume II, Appendix F.

### 5.11.1.6.2.1 Health Impacts from Routine Radionuclide Releases

The calculated doses and health impacts to non-involved workers and public from routine atmospheric releases of radionuclides are presented in Table 5.73 for the Hanford Only waste volume and in Table 5.74 for the Lower Bound waste volume. The tables present the maximum annual dose to the non-involved workers and the public, the collective dose to the public, and the associated risk of LCF for the exposures that occur during the period covered by the No Action Alternative. Given that the cancer risk estimates and doses are small in comparison to regulatory limits,<sup>(a)</sup> no adverse health impacts would be expected from radionuclide releases.

**Table 5.73.** Non-Involved Worker and Public Health Impacts from Routine Atmospheric Releases of Radionuclides – No Action Alternative, Hanford Only Waste Volume

Exposed Group	Exposure Scenario <sup>(a)</sup>	Facility	Lifetime Dose <sup>(b)</sup> (mrem)	Probability of an LCFs <sup>(c)</sup>	Maximum Annual Dose	
					Year	(mrem)
Worker Onsite (non-involved)	Industrial	WRAP	1.2E-03	7E-10	2004	1.3E-04
		T Plant Complex	4.8E-01	3E-07	2003	3.9E-02
		Leachate Treatment <sup>(d,e)</sup>	2.1E-08	2E-14	2029	3.7E-09
MEI Offsite	Resident Gardener	WRAP	9.9E-05	6E-11	2004	1.1E-05
		T Plant Complex	1.0E-03	6E-10	2003	7.9E-05
		Leachate Treatment	1.1E-11	6E-18	2029	1.8E-12
		Total	1.1E-03	7E-10	2003	8.9E-05
			<b>(person-rem)</b>	<b>Number of LCFs<sup>(f)</sup></b>	<b>Year</b>	<b>(person-rem)</b>
Population <sup>(g)</sup>	Population within 50 mi. (80 km)	WRAP	9.1E-03	0 (5E-06)	2004	7.4E-04
		T Plant Complex	9.2E-02	0 (6E-05)	2003	5.5E-03
		Leachate Treatment	9.5E-10	0 (6E-13)	2029	1.3E-10
		Total	1.0E-01	0 (6E-05)	2003	6.3E-03
<p>(a) The exposure duration for the industrial scenario is 20 years and for the resident gardener, 30 years. The exposure scenarios are described in Volume II, Appendix F.</p> <p>(b) The lifetime dose is the radiation dose received from intake during the exposure period and up to 50 years after exposure due to radionuclides deposited in the body during the exposure period.</p> <p>(c) LCF = latent cancer fatality.</p> <p>(d) Leachate treatment is a pulse drier operation.</p> <p>(e) If LLW trenches were to be lined, the doses from leachate collection and treatment might be as much as three times the leachate treatment values shown in this table.</p> <p>(f) The value in parentheses is the calculated value based on the population dose and the appropriate health effects conversion factor. The actual number of LCFs must be a whole number (deaths).</p> <p>(g) The population lifetime impacts are based on exposure for the same exposure pathways impacting the resident gardener MEI.</p>						

(a) The maximum annual radiation dose presented in this section may be compared to the regulatory limit of 10 mrem/year (WAC 246-247; 40 CFR 61; DOE 1993).

**Table 5.74.** Non-Involved Worker and Public Health Impacts from Routine Atmospheric Releases of Radionuclides – No Action Alternative, Lower Bound Waste Volume

Exposed Group	Exposure Scenario <sup>(a)</sup>	Facility	Lifetime Dose <sup>(b)</sup> (mrem)	Probability of an LCFs <sup>(c)</sup>	Maximum Annual Dose	
					Year	(mrem)
Worker Onsite (non-involved)	Industrial	WRAP	1.4E-03	9E-10	2004	1.6E-04
		T Plant Complex	5.8E-01	3E-07	2003	4.8E-02
		Leachate Treatment <sup>(d,e)</sup>	2.1E-08	2E-14	2029	3.7E-09
MEI Offsite	Resident Gardener	WRAP	1.2E-04	7E-11	2004	1.3E-05
		T Plant Complex	1.2E-03	7E-10	2003	9.5E-05
		Leachate Treatment	1.1E-11	6E-18	2029	1.8E-12
		Total	1.3E-03	8E-10	2003	1.1E-04
			(person-rem)	Number of LCFs <sup>(f)</sup>	Year	(person-rem)
Population <sup>(g)</sup>	Population within 50 mi. (80 km)	WRAP	1.1E-02	0 (6E-06)	2004	8.8E-04
		T Plant Complex	1.1E-01	0 (7E-05)	2003	6.7E-03
		Leachate Treatment	9.5E-10	0 (6E-13)	2029	1.3E-10
		Total	1.2E-01	0 (7E-05)	2003	7.6E-03
<p>(a) The exposure duration for the industrial scenario is 20 years and for the resident gardener, 30 years. The exposure scenarios are described in Volume II, Appendix F.</p> <p>(b) The lifetime dose is the radiation dose received from intake during the exposure period and up to 50 years after exposure due to radionuclides deposited in the body during the exposure period.</p> <p>(c) LCF = latent cancer fatality.</p> <p>(d) Leachate treatment is a pulse drier operation.</p> <p>(e) If LLW trenches were to be lined, the doses from leachate collection and treatment might be as much as three times the leachate treatment values shown in this table.</p> <p>(f) The value in parentheses is the calculated value based on the population dose and the appropriate health effects conversion factor. The actual number of LCFs must be a whole number (deaths).</p> <p>(g) The population lifetime impacts are based on exposure for the same exposure pathways impacting the resident gardener MEI.</p>						

Potential impacts to public health from normal operations include impacts from atmospheric releases of radionuclides and chemicals from waste operations. Radiation dose to workers involved with waste operations is also evaluated.

#### 5.11.1.6.2.2 Health Impacts from Chemical Releases

Releases of chemicals to the atmosphere could occur for the same processes involving radionuclide release when wastes with hazardous chemicals are involved. The potential health impacts from chemical releases to the atmosphere are presented in Table 5.75. The results for the Hanford Only waste volume are the same as those for the Lower Bound waste volume because the processing volumes for mixed waste streams are nearly identical for both cases (only mixed wastes contain chemicals that may be released to the atmosphere). Given that the peak hazard quotients are all less than 1, and because the cancer risk estimates are small, no adverse health impacts would be expected from chemical releases.



**Table 5.75.** Non-Involved Worker and Public Health Impacts from Routine Atmospheric Releases of Chemicals – No Action Alternative

Exposed Group	Exposure Scenario <sup>(a)</sup>	Facility	Risk of Cancer Incidence <sup>(b)</sup>	Peak Annual Hazard Quotient <sup>(c)</sup>
Worker Onsite (non-involved)	Industrial	WRAP	1.2E-09	8.9E-05
		T Plant Complex	3.2E-08	2.3E-03
MEI Offsite	Resident Gardener	WRAP	5.6E-11	3.4E-06
		T Plant Complex	3.3E-11	2.0E-06
		Total	8.9E-11	5.3E-06
Population	Population within 50 mi. (80 km)	WRAP	0 (5.0E-06) <sup>(d)</sup>	NA <sup>(e,f)</sup>
		T Plant Complex	0 (3.0E-06) <sup>(d)</sup>	NA
		Total	0 (8.0E-06) <sup>(d)</sup>	NA

(a) The exposure duration for the industrial scenario is 20 years and for the resident gardener 30 years. The exposure scenarios are described in Volume II, Appendix F.

(b) The individual risk of cancer incidence is evaluated for the exposure duration defined for the given exposure scenario starting in the year that provides the highest total impact.

(c) Hazard quotients are reported for the year of highest exposure.

(d) Population risk from cancer is expressed as the inferred number of fatal and non-fatal cancers in the exposed population over the lifetime of the population from intakes during the remediation period. The actual value must be a whole number (cancers).

(e) Hazard quotients are designed as a measure of impacts on an individual and are not meaningful for population exposures.

(f) NA = not applicable.

### 5.11.1.6.2.3 Worker Occupational Radiation Exposure

The radiation dose received by workers involved with waste operations is estimated using historical exposure data for the facilities involved in the No Action Alternative, as provided in the Technical Information Document (FH 2004). The exposure to involved workers is summarized in Table 5.76 for the Hanford Only waste volume. The estimated impacts are the same for the Hanford Only waste volume and the Lower Bound waste volume because the labor requirements are essentially the same. The worker category “Other” includes engineers, maintenance personnel, and general support staff (for example, administrative and clerical workers). All estimated radiation doses to workers are well below regulatory limits.<sup>(a)</sup>

### 5.11.1.6.3 Accidents

The impacts of accidents involving radiological and chemical contaminants and industrial accidents are evaluated in this section. The impacts of these accidents are expected to bound impacts of events that could be initiated by malevolent intent. Continuing waste management operations under the No Action Alternative would involve a continuing potential for accidental release that would be very similar to those discussed for Alternative Group A in four Hanford facilities: the CWC for waste storage, the WRAP for

(a) The annual limit for occupational exposures is 5000 mrem/year (10 CFR 835).

**Table 5.76. Occupational Radiation Exposure – No Action Alternative, Hanford Only  
Waste Volume**

Facility	Operating Period	Worker Category <sup>(a)</sup>	Workers (FTE) <sup>(b)</sup>	Average Dose Rate (mrem/yr)	Workforce Dose (person-rem)	Workforce LCFs <sup>(c)</sup>
LLW and MLLW Trenches	2002–2046	Operator	14	54	34	0 (2E-02)
		RCT	4	45	8.5	0 (5E-03)
		Other	66	35	103	0 (6E-02)
ILAW	2008–2028	Workers	52	300 <sup>(e)</sup>	422	0 (3E-01)
	2032–2046	Workers	37	14	5.2	0 (3E-03)
CWC	2002–2008	Operator	12	54	4.5	0 (3E-03)
		RCT	4	45	1.3	0 (8E-04)
		Other	55	17	6.5	0 (4E-03)
	2009–2032	Operator	30	54	39	0 (2E-02)
		RCT	10	45	11	0 (7E-03)
		Other	140	17	57	0 (3E-02)
	2033–2046	Operator	48	54	36	0 (2E-02)
		RCT	17	45	11	0 (6E-03)
		Other	218	17	52	0 (3E-02)
WRAP	2002–2032	Operator	13	18	7.3	0 (4E-03)
		RCT	9	36	10	0 (6E-03)
		Other	29	13	12	0 (7E-03)
	2033–2039	Operator	9	18	1.2	0 (7E-04)
		RCT	6	36	1.6	0 (1E-03)
		Other	21	13	1.9	0 (1E-03)
T Plant Complex	2002–2032	Operator	20	9	5.6	0 (3E-03)
		RCT	18	13	7.3	0 (4E-03)
		Other	38	7	8.2	0 (5E-03)
	2033–2046	Operator	14	9	1.7	0 (1E-03)
		RCT	13	13	2.3	0 (1E-03)
		Other	27	7	2.6	0 (2E-03)
Generator Staff <sup>(f)</sup>	2002–2019	Operator	15	34	9.2	0 (6E-03)
		RCT	12	35	7.6	0 (5E-03)
	2020–2026	Operator	5	34	1.2	0 (7E-04)
		RCT	3	35	0.7	0 (4E-04)
	2027–2044	Operator	1	34	0.6	0 (4E-04)
		RCT	1	35	0.6	0 (4E-04)
Pulse Driers	2026–2039	Operator <sup>(d)</sup>	0.5	54	0.5	0 (8E-04)
<b>Total</b>					<b>873</b>	<b>1 (5.2E-01)</b>
<p>(a) RCT = radiation control technician.</p> <p>(b) The number of workers is the average necessary for the facility during the indicated period.</p> <p>(c) LCF = latent cancer fatality. Workforce LCFs are the inferred number of cancer deaths in the exposed workforce, which must be a whole number (deaths). The value in parentheses is the calculated value based on the workforce dose and the appropriate health effects conversion factor.</p> <p>(d) Operators are provided by contract with the vendor operating the pulse drier unit. Radiological monitoring (RCT) resources are included with the RCT resources for LLW/MLLW trenches.</p> <p>(e) The dose rates for placement of ILAW into disposal facilities are higher than for other solid waste management operations because the material emits more radiation.</p> <p>(f) Staff in the solid waste support services group that work as needed in various solid waste facilities.</p>						

waste treatment, the modified T Plant Complex also for waste treatment, and the LLBGs for waste disposal. Potential radiological impacts of accidents from ILAW disposal would be somewhat lower than other alternatives.

Potential health impacts to workers from industrial accidents would be the same as Alternative Group A for treatment activities in the WRAP and are not discussed further. Differences would be expected for the CWC, modified T Plant Complex, and LLBGs (including ILAW disposal) and are discussed below.

Anticipated health impacts to all workers from industrial accidents during construction and operations would be 770 total recordable cases, 320 lost workday cases, and 10,900 lost workdays. A total of about 25,700 worker-years would be required to complete all activities. Of these worker-years, about 2600 are site support and waste generator-paid workers that do not appear in the direct facility worker and impact estimates in the following sections. About 95 to 97 percent of these health impacts are from operations.

#### 5.11.1.6.3.1 Storage – Central Waste Complex

Potential radiological and non-radiological accidents and impacts for the CWC under the No Action Alternative would be similar to those for Alternative Group A (see Section 5.11.1.1.3.1) but also include two cases of a melter drop accident (filtered and unfiltered) shown in Table 5.77. Accidents described under Alternative Group A, which also apply to the No Action Alternative, have higher estimated consequences than the melter drop and would bound the consequences of that event.

**Industrial Accidents-Construction.** Construction of long-term storage buildings at the CWC would require 330 worker-years. The estimated health and safety impacts would be 27 recordable cases, 9 lost workday cases, and 180 lost workdays.

**Industrial Accidents-Operations.** Direct operations staffing in the CWC would require 8700 worker-years. The estimated health and safety impacts would be 230 recordable cases, 97 lost workday cases, and 3400 lost workdays.

**Table 5.77.** Radiological Consequences of Melter Storage Accidents at the CWC

Accident	Estimated Annual Frequency	Offsite MEI		Population		Non-Involved Worker	
		Dose (rem)	Prob. LCF <sup>(a)</sup>	Dose (person-rem)	Number LCFs <sup>(b)</sup>	Dose (rem)	Prob. LCF <sup>(a)</sup>
HWVP Melter Drop (filtered)	3.1E-04	1.7E-05	1E-08	0.042	0 (3E-05)	4.4E-03	3E-06
HWVP Melter Drop (unfiltered)	3.1E-04	3.5E-02	2E-05	84	0 (5E-02)	8.7E+00	5E-03

(a) Prob. LCF = the probability of a latent cancer fatality in the hypothetically exposed individual.  
(b) Number LCFs = the number of latent cancer fatalities in the hypothetically exposed population. Value indicated in parentheses if less than one fatality estimated.

#### **5.11.1.6.3.2 Treatment – WRAP**

Potential radiological, non-radiological, and industrial accidents and impacts for the WRAP under the No Action Alternative would be the same as for Alternative Group A (see Section 5.11.1.1.3.2).

#### **5.11.1.6.3.3 Treatment – Modified T Plant Complex**

Potential radiological and non-radiological (chemical) accidents and impacts for modified T Plant Complex under the No Action Alternative would be the same as for the continuing T Plant activities under Alternative Group A (see Section 5.11.1.1.3.3).

**Industrial accidents – construction.** Under the No Action Alternative, there would be no new construction at the modified T Plant Complex. No construction impacts would occur.

**Industrial accidents – operations.** Direct operations staffing would be less than either Alternative Group A or Group B, requiring 3100 worker-years. The estimated health and safety impacts would be 82 total recordable cases, 34 lost workday cases, and 1200 lost workdays. These estimates are based on Hanford Site non-construction occupational injury statistics from 1996 through 2000 (see Section 4.9).

#### **5.11.1.6.3.4 Disposal – LLBGs**

Under the No Action Alternative, potential radiological and non-radiological accidents and impacts for the LLBGs would be the same as for Alternative Group A except for a radiological accident involving ILAW disposal (see Section 5.11.1.1.3.4). The radiological impact of an accident involving ILAW would involve one ILAW container and, therefore, be about one-sixth of the impacts estimated for the bulldozer accident in Table 5.44. Industrial accidents are discussed below.

**Industrial accidents – construction.** Construction under the No Action Alternative would require 44 worker-years, slightly less than the lower bound of Alternative Group B but more than Alternative Group A. The estimated health and safety impacts would be 4 total recordable cases, 1 lost workday case, and 24 lost workdays.

**Industrial accidents – operations.** Industrial accidents from LLBG operations would be the same as Alternative Group A and are not discussed further.

**ILAW industrial accidents.** Industrial impacts include both construction and operations. A total of about 5,200 worker-years would be required to construct vaults and temporary storage facilities, maintain permanent disposal operations and facilities, and perform closure activities. The estimated health and safety impacts would be about 200 total recordable cases, 84 lost workday cases, and 2900 lost workdays.

## 5.11.2 Long-Term Human Health and Safety Impacts

This section considers potential impacts on human health over long time periods. The impacts are evaluated for releases to soil and groundwater, with subsequent transport to the Columbia River, and for inadvertent intrusion into the disposal facilities in the absence of institutional controls.

### 5.11.2.1 Water Pathway Scenarios

The impacts from waterborne pathways are presented in the following sections for each alternative. The results are presented for each waste category as appropriate to each alternative. The impacts from previously disposed of waste are the same for all alternatives and waste volumes because the waste is currently in place and is not planned to be moved under any alternative. The impacts for the previously disposed of waste are presented along with the results for each alternative for completeness of each table. Downstream impacts from material entering the Columbia River are also evaluated.

Releases of radionuclides and chemicals to the unsaturated soil beneath the disposal facilities may occur as the waste packages degrade and water seeps through the waste. The potential sources of groundwater contamination are wastes contained in the disposal facilities, the mixed waste trenches in the 200 East and the 200 West Areas, and, for some alternative groups, the ERDF site southeast of the 200 West Area. These wastes include LLW disposed of before 1970 and during the 1970-1988 time-frame. In addition, LLW categories disposed of after 1988 include Cat 1 wastes, Cat 3 wastes, MLLW, ILAW, and melters from the vitrification processing. Contributions from ILAW are taken from the ILAW performance assessment (Mann et al. 2001).

The estimated health impacts, based on the groundwater analyses, are represented as the radiation dose received by a hypothetical person that might reside on the Hanford Site in the future. Three scenarios were evaluated for use of groundwater: 1) a hypothetical resident gardener, 2) a hypothetical resident gardener with a sauna/sweat lodge exposure pathway, and 3) an individual drinking 2 L of groundwater per day. Details of these exposure scenarios are presented in Volume II, Appendix F. In the following sections, the estimated annual doses for the hypothetical resident gardener scenarios are compared to the DOE all-pathway dose limit of 25 mrem/yr (DOE 2001a). The estimated annual drinking water doses may be compared with the DOE benchmark 4-mrem/yr standard for public drinking water systems (DOE 1993). As discussed in Section 5.3, the DOE 4-mrem/yr drinking water standard (as effective dose equivalent) does not correspond exactly to the 4-mrem/yr dose to the total body or maximum organ used to establish the drinking water MCLs in 40 CFR 141.

The groundwater scenarios were evaluated at points along the lines of analysis described in the groundwater transport discussions in Section 5.3.2 and Volume II, Appendix G, Section G.1.1. These lines of analysis are about 1 km (0.6 mi) from disposal facility boundaries in the 200 East and West Areas, about 1 km (0.6 mi) from the ERDF boundary, and at the locations of peak radionuclide concentration in groundwater near the Columbia River. Because groundwater flows in different directions from the 200 East Area disposal facilities, there are two lines of analysis for the 200 East Area disposal facilities: one northwest (NW) of the 200 East Area LLBGs; the other southeast (SE) of the near-PUREX location. As discussed in the following sections, most of the variation in potential health

impacts from using groundwater containing radionuclides resulted from the alternative locations and configurations for new disposal facilities; differences between the Hanford Only and Upper Bound waste volumes were minimal.

Potential long-term health risks to downstream populations using the Columbia River for drinking water were also evaluated over a 10,000-year period following closure of the disposal facilities, and results are presented in the following sections. No health effects were predicted in these downstream populations for any alternative. However, as with the groundwater scenarios, variation in potential health risks from using Columbia River water downstream of Hanford resulted from the alternative locations and configurations for new disposal facilities; differences in results between the Hanford Only and Upper Bound waste volumes were minimal.

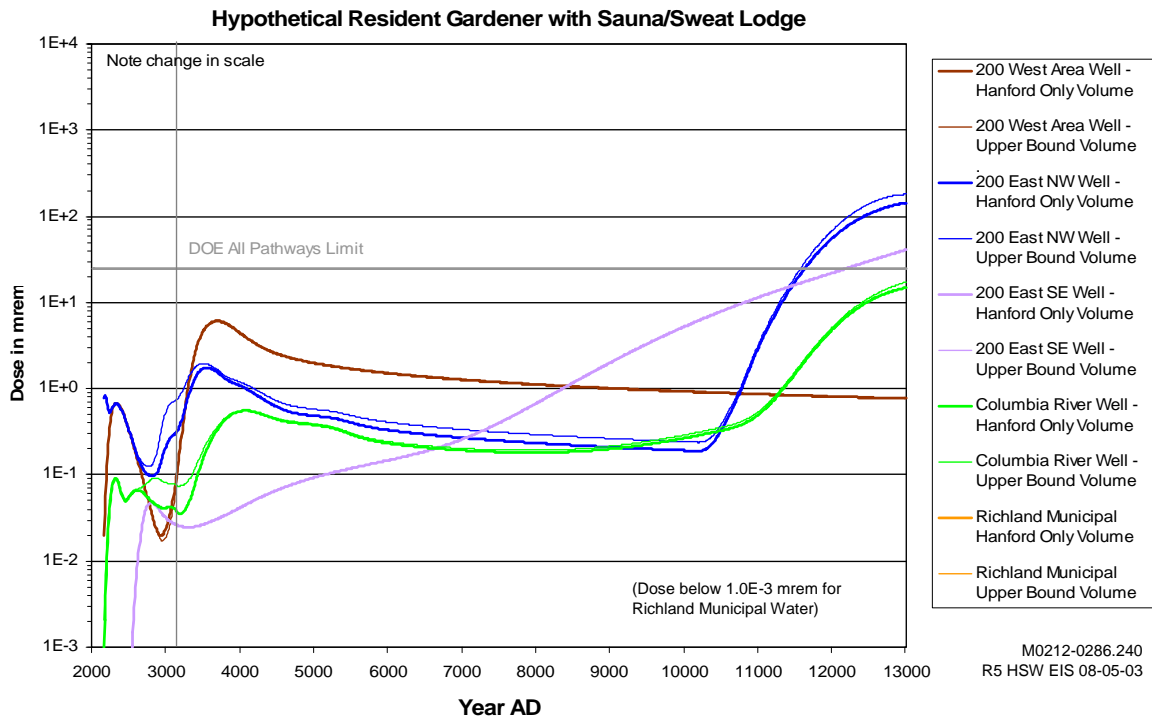
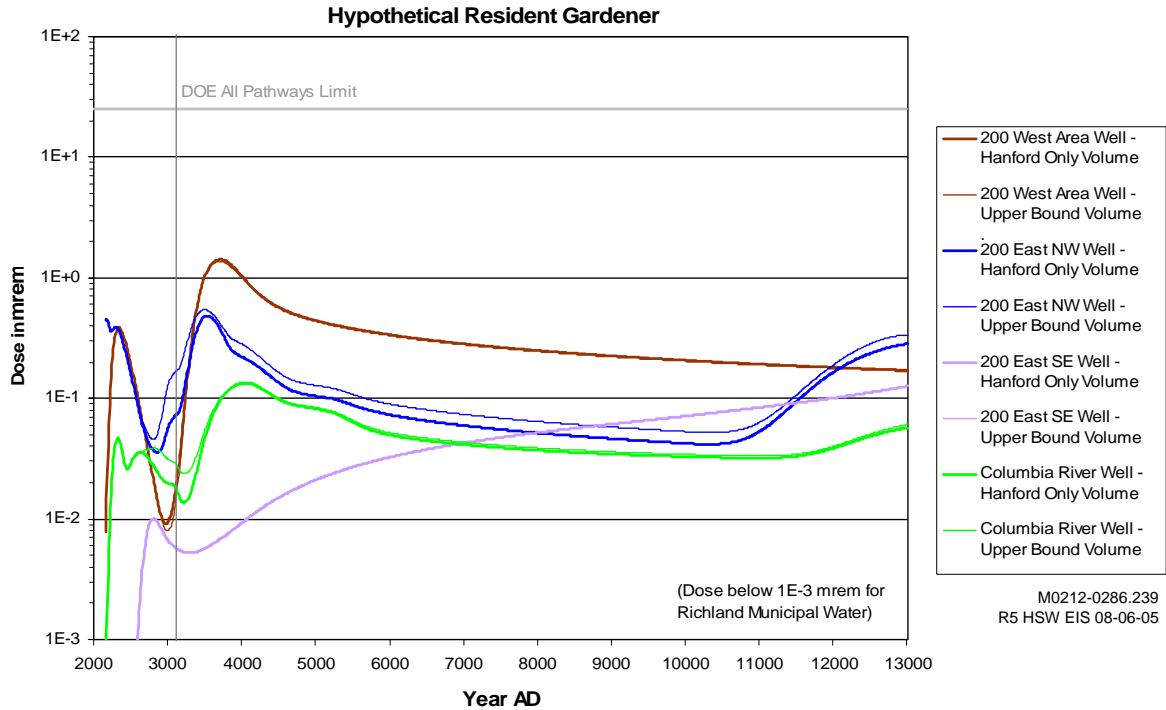
#### **5.11.2.1.1 Alternative Group A**

The potential consequences to the MEI are presented in Figure 5.34 for a hypothetical individual residing 1 km (0.6 mi) downgradient from disposal facilities, a hypothetical individual residing near the Columbia River, and for users of municipal water from the Richland water supply system. Results are presented for the Hanford Only and Upper Bound waste volumes. The results for the Lower Bound waste volume are nearly indistinguishable from the Hanford Only waste volume and are not displayed in the figure.

The estimated annual doses for the hypothetical resident gardener are well below the DOE all-pathway dose limit of 25 mrem/yr (DOE 2001a) for these locations within the 10,000-year timeframe. The estimated annual doses also are below the benchmark DOE drinking water dose limit of 4 mrem/yr (DOE 1993) for these locations within the 10,000-year timeframe. The results for the hypothetical resident gardener with the sauna/sweat lodge exposure pathway are below the 25-mrem annual limit within the 1000-year timeframe, but exceed the limit at later times (after about 9,000 years).

Impacts on users of Columbia River water downstream of Hanford were based on the collective population drinking water dose (2 L/day) for the Tri-Cities, Washington, population and a population the size of Portland, Oregon, and located at about that point on the Columbia River. The doses are calculated over the 10,000-year period and are presented in Table 5.78 for the Hanford Only waste volume, in Table 5.79 for the Lower Bound waste volume, and in Table 5.80 for the Upper Bound waste volume. All estimated collective radiation doses to downstream populations resulting from drinking Columbia River water are below levels expected to result in any LCFs.

The estimated annual drinking water dose for each of the groundwater points of analysis, represented as wells, are presented for comparison with the benchmark drinking water dose of 4 mrem/yr (DOE 1993). The results are presented in Tables 5.81 through 5.84 for the locations 1 km (0.6 mi) downgradient from the 200 West Area, from the 200 East Area (NW), and from the 200 East Area (SE), and near the Columbia River, respectively.



**Figure 5.34.** Annual Dose to a Maximally Exposed Individual at Various Times over 10,000 Years Using Water from Various Locations – Alternative Group A, Hanford Only and Upper Bound Waste Volumes

**Table 5.78.** Population Health Impacts from Drinking Water Downstream of Hanford over 10,000 Years – Alternative Group A, Hanford Only Waste Volume

Waste Type	Tri-Cities, Washington		Portland, Oregon	
	Population Dose (person-rem)	Estimated Cancer Fatalities	Population Dose (person-rem)	Estimated Cancer Fatalities
Previously Disposed of	1.3E-02	0 (8E-06) <sup>(a)</sup>	3.3E-02	0 (2E-05)
Disposed of 1996–2007	1.1E-02	0 (6E-06)	2.9E-02	0 (2E-05)
Projected	1.7E-01	0 (1E-04)	4.7E-01	0 (3E-04)
Total	2.0E-01	0 (1E-04)	5.3E-01	0 (3E-04)

(a) The numbers expressed in parentheses are the calculated numbers of fatalities using the appropriate linear health effects conversion factor. The actual value must be a whole number.

**Table 5.79.** Population Health Impacts from Drinking Water Downstream of Hanford over 10,000 Years – Alternative Group A, Lower Bound Waste Volume

Waste Type	Tri-Cities, Washington		Portland, Oregon	
	Population Dose (person-rem)	Estimated Cancer Fatalities	Population Dose (person-rem)	Estimated Cancer Fatalities
Previously Disposed of	1.3E-02	0 (8E-06) <sup>(a)</sup>	3.3E-02	0 (2E-05)
Disposed of 1996–2007	1.1E-02	0 (7E-06)	2.9E-02	0 (2E-05)
Projected	1.8E-01	0 (1E-04)	4.7E-01	0 (3E-04)
Total	2.0E-01	0 (1E-04)	5.3E-01	0 (3E-04)

(a) The numbers expressed in parentheses are the calculated numbers of fatalities using the appropriate linear health effects conversion factor. The actual value must be a whole number.

**Table 5.80.** Population Health Impacts from Drinking Water Downstream of Hanford over 10,000 Years – Alternative Group A, Upper Bound Waste Volume

Waste Type	Tri-Cities, Washington		Portland, Oregon	
	Population Dose (person-rem)	Estimated Cancer Fatalities	Population Dose (person-rem)	Estimated Cancer Fatalities
Previously Disposed of	1.3E-02	0 (8E-06) <sup>(a)</sup>	3.3E-02	0 (2E-05)
Disposed of 1996–2007	1.7E-02	0 (1E-05)	4.6E-02	0 (3E-05)
Projected	1.8E-01	0 (1E-04)	4.9E-01	0 (3E-04)
Total	2.1E-01	0 (1E-04)	5.7E-01	0 (3E-04)

(a) The numbers expressed in parentheses are the calculated numbers of fatalities using the appropriate linear health effects conversion factor. The actual value must be a whole number.



**Table 5.81.** Maximum Annual Drinking Water Dose for a Hypothetical Well 1 km Downgradient from the 200 West Area, Alternative Group A

Waste Volume	Radionuclide	Maximum Annual Dose	
		Dose, mrem	Years post-2046
Hanford Only	Carbon-14	0.0	Not present
	Technetium-99	3.6E-01	1640
	Iodine-129	1.1E-01	280
	Uranium <sup>(a)</sup>	0.0	Not present
	Total	4.2E-01	1660
Upper Bound	Carbon-14	0.0	Not present
	Technetium-99	3.5E-01	1630
	Iodine-129	1.1E-01	280
	Uranium <sup>(a)</sup>	0.0	Not present
	Total	4.0E-01	1650

(a) The entry for uranium includes the contributions from all uranium isotopes.

**Table 5.82.** Maximum Annual Drinking Water Dose for a Hypothetical Well 1 km Downgradient Northwest from the 200 East Area, Alternative Group A

Waste Volume	Radionuclide	Maximum Annual Dose	
		Dose, mrem	Years post-2046
Hanford Only	Carbon-14	2.5E-03	10,000
	Technetium-99	9.2E-02	1,520
	Iodine-129	1.1E-01	120
	Uranium <sup>(a)</sup>	5.7E-02	10,000
	Total	1.5E-01	1,480
Upper Bound	Carbon-14	2.5E-03	10,000
	Technetium-99	1.0E-01	1,470
	Iodine-129	1.1E-01	120
	Uranium <sup>(a)</sup>	7.1E-02	10,000
	Total	1.7E-01	1,440

(a) The entry for uranium includes the contributions from all uranium isotopes.

**Table 5.83.** Maximum Annual Drinking Water Dose for a Hypothetical Well 1 km Downgradient Southeast from the 200 East Area, Alternative Group A

Waste Volume	Radionuclide	Maximum Annual Dose	
		Dose, mrem	Years post-2046
Hanford Only	Carbon-14	0.0	Not present
	Technetium-99	1.9E-2	10,000
	Iodine-129	3.2E-3	10,000
	Uranium <sup>(a)</sup>	2.1E-2	10,000
	Total	4.4E-2	10,000
Upper Bound	Carbon-14	0.0	Not present
	Technetium-99	1.9E-2	10,000
	Iodine-129	3.2E-3	10,000
	Uranium <sup>(a)</sup>	2.1E-2	10,000
	Total	4.4E-2	10,000

(a) The entry for uranium includes the contributions from all uranium isotopes.

**Table 5.84.** Maximum Annual Drinking Water Dose for a Hypothetical Well Near the Columbia River, Alternative Group A

Waste Volume	Radionuclide	Maximum Annual Dose	
		Dose, mrem	Years post-2046
Hanford Only	Carbon-14	1.2E-4	10,000
	Technetium-99	3.2E-2	2,040
	Iodine-129	1.3E-2	270
	Uranium <sup>(a)</sup>	4.7E-3	10,000
	Total	4.0E-2	2,000
Upper Bound	Carbon-14	1.2E-4	10,000
	Technetium-99	3.2E-2	2,040
	Iodine-129	1.3E-2	270
	Uranium <sup>(a)</sup>	4.8E-3	10,000
	Total	3.9E-2	1,990

(a) The entry for uranium includes the contributions from all uranium isotopes.

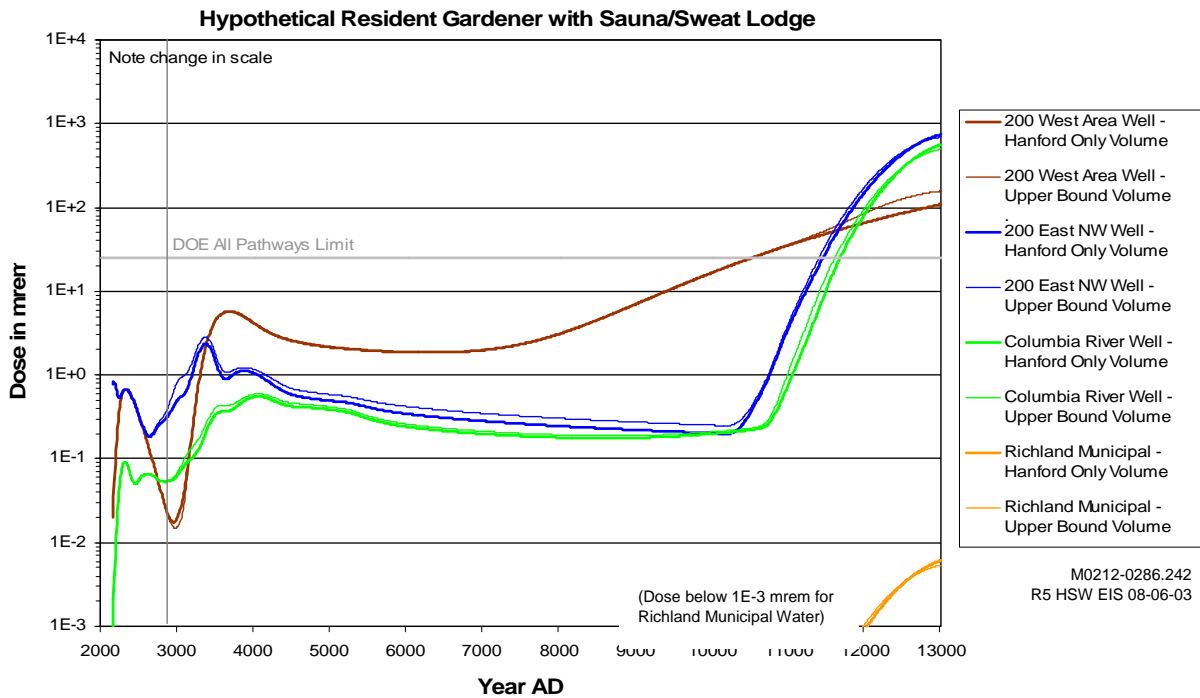
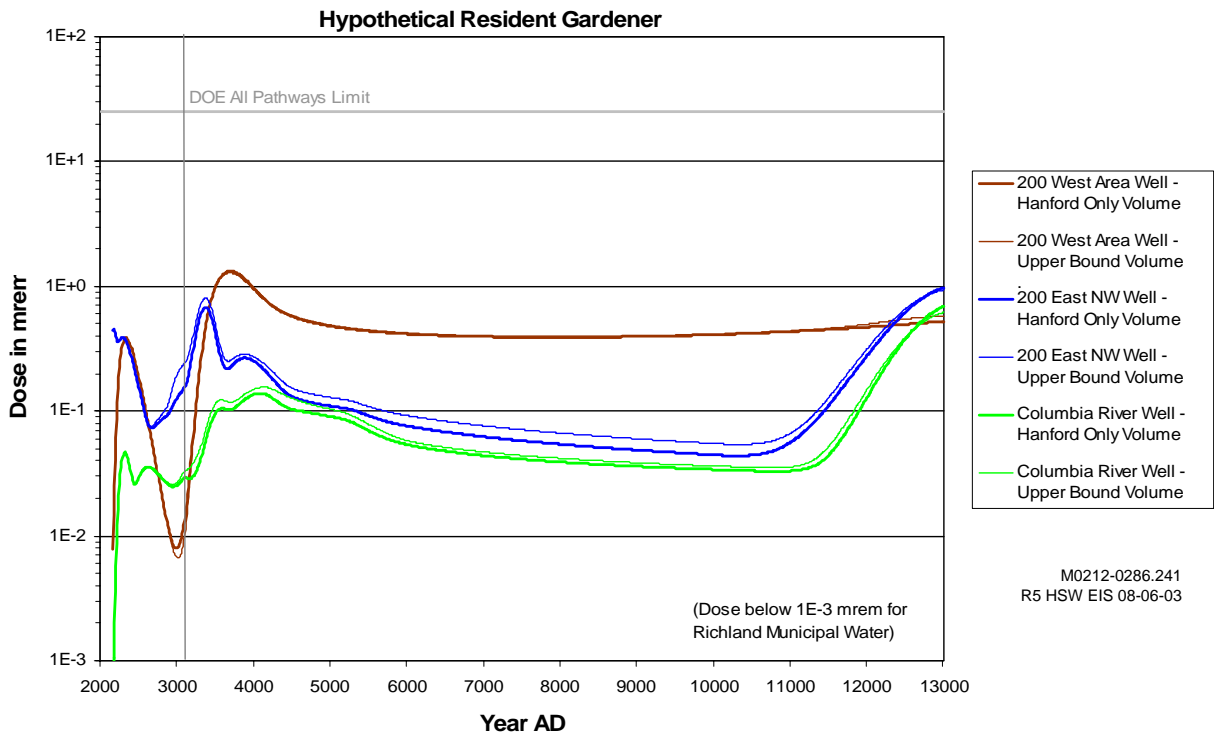
### 5.11.2.1.2 Alternative Group B

The potential consequences to the MEI are presented in Figure 5.35 for a hypothetical individual residing 1 km (0.6 mi) downgradient from disposal facilities, a hypothetical individual residing near the Columbia River, and for users of municipal water from the Richland water supply system. Results are presented for the Hanford Only and Upper Bound waste volumes. The results for the Lower Bound waste volume are nearly indistinguishable from the Hanford Only waste volume and are not displayed on the figure.

The estimated annual doses for the hypothetical resident gardener are well below the DOE all-pathway dose limit of 25 mrem/yr (DOE 2001a) for these locations within the 10,000-year timeframe. The estimated annual doses also are below the benchmark DOE drinking water dose limit of 4 mrem/yr (DOE 1993) for these locations within the 10,000-year timeframe. The results for the hypothetical resident gardener with the sauna/sweat lodge exposure pathway are below the 25-mrem annual limit within the 1000-year timeframe, but exceed the limit at later times (after about 8,000 years).

Impacts on users of Columbia River water downstream of Hanford were based on the collective population drinking water dose (2 L/day) for the Tri-Cities, Washington, population and a population the size of Portland, Oregon, and located at about that point on the Columbia River. The doses are calculated over the 10,000-year period and are presented in Table 5.85 for the Hanford Only waste volume, in Table 5.86 for the Lower Bound waste volume, and in Table 5.87 for the Upper Bound waste volume. All estimated collective radiation doses to downstream populations resulting from drinking Columbia River water are below levels that would be expected to result in any LCFs.

The estimated annual drinking water dose for each of the groundwater points of analysis, represented as wells, are presented for comparison with the benchmark drinking water dose of 4 mrem/yr (DOE 1993). The results are presented in Tables 5.88 through 5.90 for the locations 1 km (0.6 mi) downgradient from the 200 West Area, from the 200 East Area (NW), and near the Columbia River, respectively.



**Figure 5.35.** Annual Dose to a Maximally Exposed Individual at Various Times over 10,000 Years Using Water from Various Locations – Alternative Group B, Hanford Only and Upper Bound Waste Volumes

**Table 5.85.** Population Health Impacts from Drinking Water Downstream of Hanford over 10,000 Years – Alternative Group B, Hanford Only Waste Volume

Waste Type	Tri-Cities, Washington		Portland, Oregon	
	Population Dose (person-rem)	Estimated Cancer Fatalities	Population Dose (person-rem)	Estimated Cancer Fatalities
Previously Disposed of	1.3E-02	0 (8E-06) <sup>(a)</sup>	3.3E-02	0 (2E-05)
Disposed of 1996–2007	7.2E-03	0 (4E-06)	1.9E-02	0 (1E-05)
Projected	1.8E-01	0 (1E-04)	4.7E-01	0 (3E-04)
Total	2.0E-01	0 (1E-04)	5.3E-01	0 (3E-04)

(a) The numbers expressed in parentheses are the calculated numbers of fatalities using the appropriate linear health effects conversion factor. The actual value must be a whole number.

**Table 5.86.** Population Health Impacts from Drinking Water Downstream of Hanford over 10,000 Years – Alternative Group B, Lower Bound Waste Volume

Waste Type	Tri-Cities, Washington		Portland, Oregon	
	Population Dose (person-rem)	Estimated Cancer Fatalities	Population Dose (person-rem)	Estimated Cancer Fatalities
Previously Disposed of	1.3E-02	0 (8E-06) <sup>(a)</sup>	3.3E-02	0 (2E-05)
Disposed of 1996–2007	7.3E-03	0 (4E-06)	2.0E-02	0 (1E-05)
Projected	1.8E-01	0 (1E-04)	4.8E-01	0 (3E-04)
Total	2.0E-01	0 (1E-04)	5.3E-01	0 (3E-04)

(a) The numbers expressed in parentheses are the calculated numbers of fatalities using the appropriate linear health effects conversion factor. The actual value must be a whole number.

**Table 5.87.** Population Health Impacts from Drinking Water Downstream of Hanford over 10,000 Years – Alternative Group B, Upper Bound Waste Volume

Waste Type	Tri-Cities, Washington		Portland, Oregon	
	Population Dose (person-rem)	Estimated Cancer Fatalities	Population Dose (person-rem)	Estimated Cancer Fatalities
Previously Disposed of	1.3E-02	0 (8E-06) <sup>(a)</sup>	3.3E-02	0 (2E-05)
Disposed of 1996–2007	1.3E-02	0 (8E-06)	3.5E-02	0 (2E-05)
Projected	1.9E-01	0 (1E-04)	5.2E-01	0 (3E-04)
Total	2.2E-01	0 (1E-04)	5.9E-01	0 (4E-04)

(a) The numbers expressed in parentheses are the calculated numbers of fatalities using the appropriate linear health effects conversion factor. The actual value must be a whole number.

**Table 5.88.** Maximum Annual Drinking Water Dose for a Hypothetical Well 1 km Downgradient from the 200 West Area, Alternative Group B

Waste Volume	Radionuclide	Maximum Annual Dose	
		Dose, mrem	Years post-2046
Hanford Only	Carbon-14	0.0	Not Present
	Technetium-99	3.4E-01	1,640
	Iodine-129	1.1E-01	280
	Uranium <sup>(a)</sup>	6.2E-02	10,000
	Total	3.9E-01	1,650
Upper Bound	Carbon-14	0.0	Not Present
	Technetium-99	3.4E-01	1,620
	Iodine-129	1.1E-01	280
	Uranium <sup>(a)</sup>	8.3E-02	10,000
	Total	3.9E-01	1,650

(a) The entry for uranium includes the contributions from all uranium isotopes.

**Table 5.89.** Maximum Annual Drinking Water Dose for a Hypothetical Well 1 km Downgradient Northwest from the 200 East Area, Alternative Group B

Waste Volume	Radionuclide	Maximum Annual Dose	
		Dose, mrem	Years post-2046
Hanford Only	Carbon-14	2.5E-03	10,000
	Technetium-99	1.2E-01	1,330
	Iodine-129	1.1E-01	120
	Uranium <sup>(a)</sup>	1.6E-01	10,000
	Total	2.1E-01	1,330
Upper Bound	Carbon-14	2.5E-03	10,000
	Technetium-99	1.5E-01	1,320
	Iodine-129	1.1E-01	120
	Uranium <sup>(a)</sup>	1.9E-01	10,000
	Total	2.5E-01	1,320

(a) The entry for uranium includes the contributions from all uranium isotopes.

**Table 5.90.** Maximum Annual Drinking Water Dose for a Hypothetical Well Near the Columbia River, Alternative Group B

Waste Volume	Radionuclide	Maximum Annual Dose	
		Dose, mrem	Years post-2046
Hanford Only	Carbon-14	4.3E-04	2,330
	Technetium-99	3.1E-02	2,020
	Iodine-129	1.3E-02	270
	Uranium <sup>(a)</sup>	5.3E-03	10,000
	Total	4.0E-02	2,000
Upper Bound	Carbon-14	1.2E-03	2,330
	Technetium-99	3.3E-02	2,000
	Iodine-129	1.4E-02	1,510
	Uranium <sup>(a)</sup>	6.9E-03	10,000
	Total	4.2E-02	1,990

(a) The entry for uranium includes the contributions from all uranium isotopes.

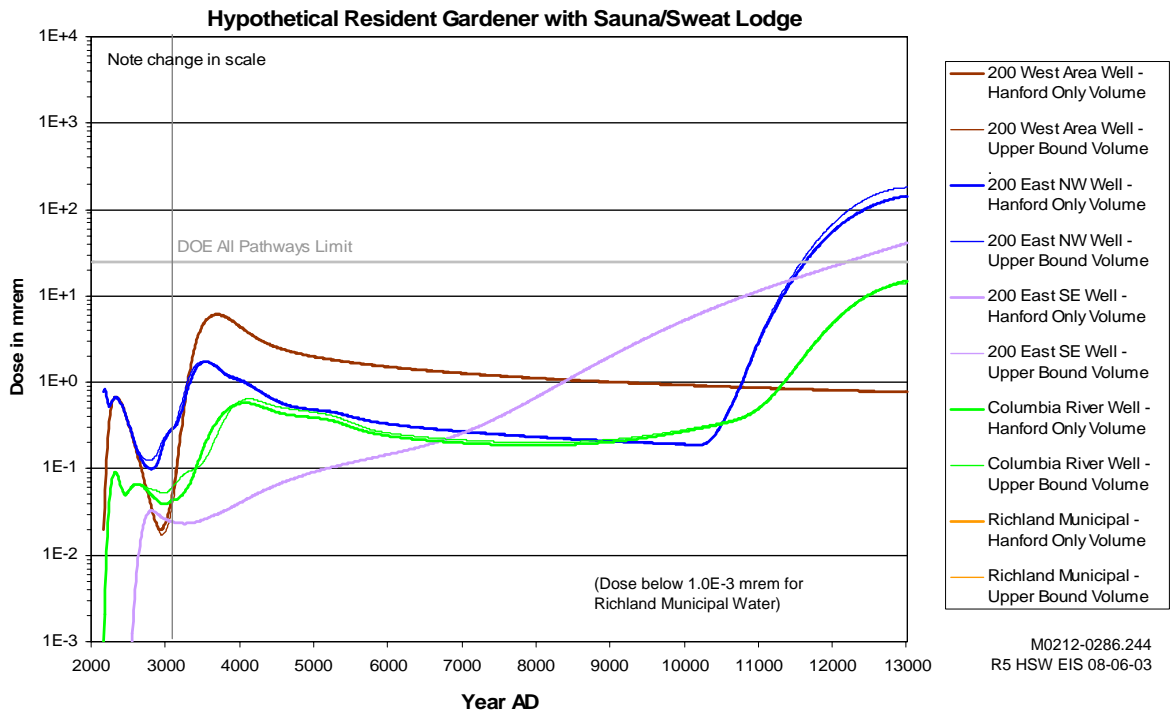
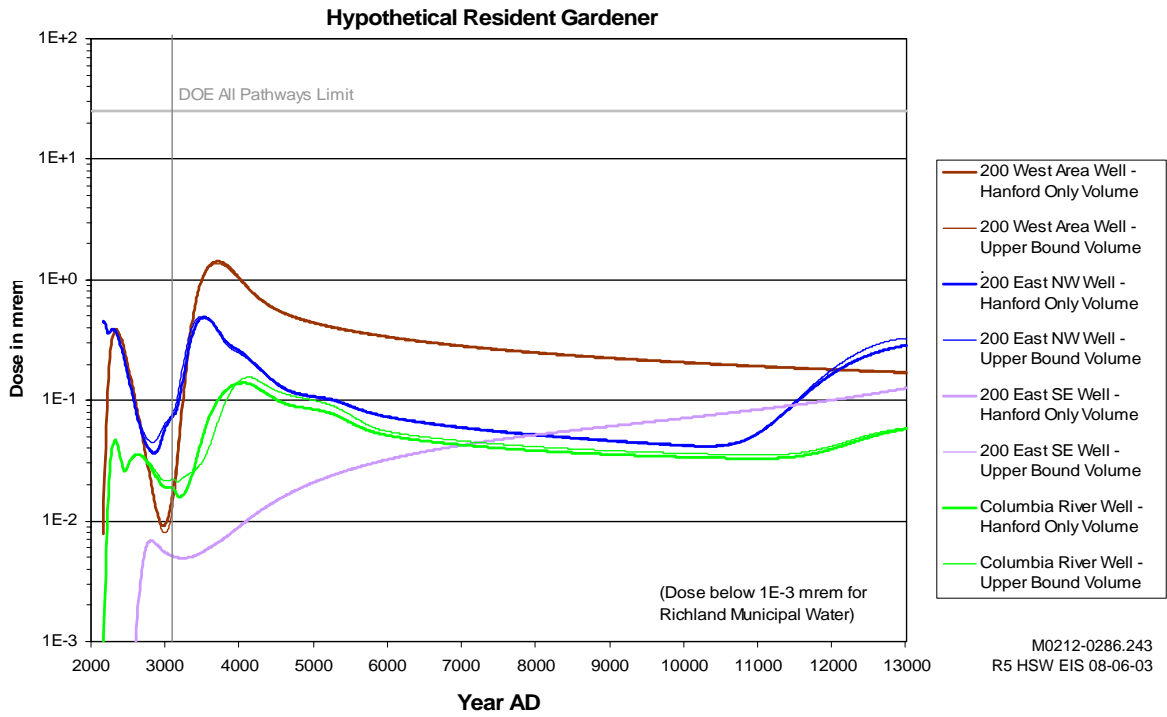
### 5.11.2.1.3 Alternative Group C

The potential consequences to the MEI are presented in Figure 5.36 for a hypothetical individual residing 1 km (0.6 mi) downgradient from disposal facilities, a hypothetical individual residing near the Columbia River, and for users of municipal water from the Richland water supply system. Results are presented for the Hanford Only and Upper Bound waste volumes. The results for the Lower Bound waste volume are nearly indistinguishable from the Hanford Only waste volume and are not displayed on the figure.

The estimated annual doses for the hypothetical resident gardener are well below the DOE all-pathway dose limit of 25 mrem/yr (DOE 2001a) for these locations within the 10,000-year timeframe. The estimated annual doses also are below the benchmark DOE drinking water dose limit of 4 mrem/yr (DOE 1993) for these locations within the 10,000-year timeframe. The results for the hypothetical resident gardener with the sauna/sweat lodge exposure pathway are below the 25-mrem annual limit within the 1000-year timeframe, but exceed the limit at later times (after about 9,000 years).

Impacts on users of Columbia River water downstream of Hanford were based on the collective population drinking water dose (2 L/day) for the Tri-Cities, Washington, population and a population the size of Portland, Oregon, and located at about that point on the Columbia River. The doses are calculated over the 10,000-year period and are presented in Table 5.91 for the Hanford Only waste volume, in Table 5.92 for the Lower Bound waste volume, and in Table 5.93 for the Upper Bound waste volume. All estimated collective radiation doses to downstream populations resulting from drinking Columbia River water are below levels expected to result in any LCFs.

The estimated annual drinking water dose for each of the groundwater points of analysis, represented as wells, are presented for comparison with the benchmark drinking water dose of 4 mrem/yr (DOE 1993). The results are presented in Tables 5.94 through 5.97 for the locations 1 km (0.6 mi) downgradient from the 200 West Area, from the 200 East Area (NW), from the 200 East Area (SE), and near the Columbia River, respectively.



**Figure 5.36.** Annual Dose to a Maximally Exposed Individual at Various Times over 10,000 Years Using Water from Various Locations – Alternative Group C, Hanford Only and Upper Bound Waste Volumes



**Table 5.91.** Population Health Impacts from Drinking Water Downstream of Hanford over 10,000 Years – Alternative Group C, Hanford Only Waste Volume

Waste Type	Tri-Cities, Washington		Portland, Oregon	
	Population Dose (person-rem)	Estimated Cancer Fatalities	Population Dose (person-rem)	Estimated Cancer Fatalities
Previously Disposed of	1.3E-02	0 (8E-06) <sup>(a)</sup>	3.3E-02	0 (2E-05)
Disposed of 1996–2007	1.1E-02	0 (6E-06)	9E-02	0 (2E-05)
Projected	1.8E-01	0 (1E-04)	4.7E-01	0 (3E-04)
Total	2.0E-01	0 (1E-04)	5.3E-01	0 (3E-04)

(a) The numbers expressed in parentheses are the calculated numbers of fatalities using the appropriate linear health effects conversion factor. The actual value must be a whole number.

**Table 5.92.** Population Health Impacts from Drinking Water Downstream of Hanford over 10,000 Years – Alternative Group C, Lower Bound Waste Volume

Waste Type	Tri-Cities, Washington		Portland, Oregon	
	Population Dose (person-rem)	Estimated Cancer Fatalities	Population Dose (person-rem)	Estimated Cancer Fatalities
Previously Disposed of	1.3E-02	0 (8E-06) <sup>(a)</sup>	3.3E-02	0 (2E-05)
Disposed of 1996–2007	1.1E-03	0 (7E-06)	2.9E-02	0 (2E-05)
Projected	1.8E-01	0 (1E-04)	4.7E-01	0 (3E-04)
Total	2.0E-01	0 (1E-04)	5.3E-01	0 (3E-04)

(a) The numbers expressed in parentheses are the calculated numbers of fatalities using the appropriate linear health effects conversion factor. The actual value must be a whole number.

**Table 5.93.** Population Health Impacts from Drinking Water Downstream of Hanford over 10,000 Years – Alternative Group C, Upper Bound Waste Volume

Waste Type	Tri-Cities, Washington		Portland, Oregon	
	Population Dose (person-rem)	Estimated Cancer Fatalities	Population Dose (person-rem)	Estimated Cancer Fatalities
Previously Disposed of	1.3E-02	0 (8E-06) <sup>(a)</sup>	3.3E-02	0 (2E-05)
Disposed of 1996–2007	1.7E-02	0 (1E-05)	4.6E-02	0 (3E-05)
Projected	1.8E-01	0 (1E-04)	4.9E-01	0 (3E-04)
Total	2.1E-01	0 (1E-04)	5.7E-01	0 (3E-04)

(a) The numbers expressed in parentheses are the calculated numbers of fatalities using the appropriate linear health effects conversion factor. The actual value must be a whole number.

**Table 5.94.** Maximum Annual Drinking Water Dose for a Hypothetical Well 1 km Downgradient from the 200 West Area, Alternative Group C

Waste Volume	Radionuclide	Maximum Annual Dose	
		Dose, mrem	Years post-2046
Hanford Only	Carbon-14	0.0	Not Present
	Technetium-99	3.6E-01	1640
	Iodine-129	1.1E-01	280
	Uranium <sup>(a)</sup>	0.0	Not Present
	Total	4.2E-01	1660
Upper Bound	Carbon-14	0.0	Not Present
	Technetium-99	3.6E-01	1630
	Iodine-129	1.1E-01	280
	Uranium <sup>(a)</sup>	0.0	Not Present
	Total	4.2E-01	1650

(a) The entry for uranium includes the contributions from all uranium isotopes.

**Table 5.95.** Maximum Annual Drinking Water Dose for a Hypothetical Well 1 km Downgradient Northwest from the 200 East Area, Alternative Group C

Waste Volume	Radionuclide	Maximum Annual Dose	
		Dose, mrem	Years post-2046
Hanford Only	Carbon-14	2.5E-03	10,000
	Technetium-99	9.0E-02	1,500
	Iodine-129	1.1E-01	120
	Uranium <sup>(a)</sup>	5.7E-02	10,000
	Total	1.5E-01	1,470
Upper Bound	Carbon-14	2.5E-03	10,000
	Technetium-99	9.1E-02	1,480
	Iodine-129	1.1E-01	120
	Uranium <sup>(a)</sup>	7.1E-02	10,000
	Total	1.5E-01	1,440

(a) The entry for uranium includes the contributions from all uranium isotopes.

**Table 5.96.** Maximum Annual Drinking Water Dose for a Hypothetical Well 1 km Downgradient Southeast from the 200 East Area, Alternative Group C

Waste Volume	Radionuclide	Maximum Annual Dose	
		Dose, mrem	Years post-2046
Hanford Only	Carbon-14	0.0	Not Present
	Technetium-99	1.9E-02	10,000
	Iodine-129	3.2E-03	10,000
	Uranium <sup>(a)</sup>	2.1E-02	10,000
	Total	4.4E-02	10,000
Upper Bound	Carbon-14	0.0	Not Present
	Technetium-99	1.9E-02	10,000
	Iodine-129	3.2E-03	10,000
	Uranium <sup>(a)</sup>	2.1E-02	10,000
	Total	4.4E-02	10,000

(a) The entry for uranium includes the contributions from all uranium isotopes.

**Table 5.97.** Maximum Annual Drinking Water Dose for a Hypothetical Well Near the Columbia River, Alternative Group C

Waste Volume	Radionuclide	Maximum Annual Dose	
		Dose, mrem	Years post-2046
Hanford Only	Carbon-14	1.2E-04	10,000
	Technetium-99	3.3E-02	2,030
	Iodine-129	1.3E-02	270
	Uranium <sup>(a)</sup>	4.7E-03	10,000
	Total	4.2E-02	2,000
Upper Bound	Carbon-14	1.2E-04	10,000
	Technetium-99	3.7E-02	2,080
	Iodine-129	1.3E-02	270
	Uranium <sup>(a)</sup>	4.7E-03	10,000
	Total	4.7E-02	2,080

(a) The entry for uranium includes the contributions from all uranium isotopes.

#### 5.11.2.1.4 Alternative Group D

There are three subalternatives considered for Alternative Group D with variations on disposal options for the waste streams. See Section 5.0 for a summary of the characteristics for the three subalternatives (D<sub>1</sub>, D<sub>2</sub>, and D<sub>3</sub>) to this alternative group.

Potential long-term radiological impacts on groundwater are presented in the same manner as above for the other alternative groups using the 1-km lines of analysis. However, in response to comments received during the public comment periods on the drafts of the HSW EIS, impacts that might occur from use of groundwater 100 m downgradient from LLW management areas also were addressed for Alternative Group D in Section 5.3.6.5. The drinking water doses associated with maximum potential concentrations provided there are summarized here in Table 5.98.

As may be seen in Table 5.98 the highest drinking water doses (less than 3 mrem/yr, and below the benchmark drinking water standards) were calculated to result from wastes disposed of prior to 1996. The time of arrival of contaminants in groundwater that could lead to such doses would be well within the 100-year active institutional control period. During the institutional control period, restrictions on groundwater use would preclude individuals from receiving the peak doses shown in the table. After the end of the active institutional control period, doses in all cases would be below the DOE 4-mrem-per-year benchmark drinking water standard.

**Table 5.98.** Hypothetical Drinking Water Dose from Groundwater 100 Meters Downgradient of LLW Management Areas<sup>(a)</sup>

Hanford Only Waste Volume		Alternative D <sub>1</sub> Post-2007 Waste Disposed of Near PUREX		Alternative D <sub>2</sub> Post-2007 Waste Disposed of in LLBG 218-E-12B		Alternative D <sub>3</sub> Post-2007 Waste Disposed of at ERDF	
		Peak Dose, mrem/yr	Year AD	Peak Dose, mrem/yr	Year AD	Peak Dose, mrem/yr	Year AD
<b>Pre-2007 Waste Streams</b>							
Pre-1996	East Area	2.7	2050	2.7	2050	2.7	2,050
	West Area	1	2100	1	2100	1	2,100
Cat 1 & Cat 3 1996–2007	218-W-5	0.076	2990	0.076	2990	0.076	2,990
MLLW 1996–2007	218-W-5	0.37	2950	0.38	2990	0.38	2,990
MLLW 1996–2007 Grouted	218-W-5	0.0021	2980	0.0021	2980	0.0021	2,980
<b>Post-2007 Waste Streams</b>							
ILAW		0.059	12,000	0.24	12,000	0.2	12,000
Cat 1 LLW and MLLW		0.11	3330	0.53	3330	0.6	3,690
Cat 3 LLW		0.22	2930	0.91	2930	0.86	3,310
Grouted MLLW and Melter		0.015	2630	0.054	2630	0.049	3,010
Upper Bound Waste Volume		Alternative D <sub>1</sub> Post-2007 Waste Disposed of Near PUREX		Alternative D <sub>2</sub> Post-2007 Waste Disposed of in 218-E-12B		Alternative D <sub>3</sub> Post-2007 Waste Disposed of at ERDF	
		Peak Dose, mrem/yr	Year AD	Peak Dose, mrem/yr	Year AD	Peak Dose, mrem/yr	Year AD
<b>Pre-2007 Waste Streams</b>							
Pre-1996	East Area	2.7	2050	2.7	2050	2.7	2050
	West Area	1	2100	1	2100	1	2100
Cat 1 & Cat 3 1996–2007	218-W-5	0.089	2990	0.089	2990	0.089	2990
MLLW 1996–2007	218-E-12B	0.47	2570	0.47	2580	0.47	2570
	218-W-5	0.22	2950	0.23	2990	0.23	2990
MLLW 1996–2007 Grouted	218-E-12B	0.032	2890	0.032	2890	0.032	2890
	218-W-5	0.02	3280	0.02	3280	0.02	3280
<b>Post-2007 Waste Streams</b>							
ILAW		0.059	12,000	0.24	12,000	0.2	12,000
Cat 1 LLW		0.018	12,000	0.058	3340	0.046	3700
Cat 3 LLW and Grouted MLLW		0.24	2930	1	2930	0.74	3320
MLLW		0.1	3330	0.43	3330	0.34	3700
Melters		0.0052	2630	0.013	2630	0.0097	3020
(a) Note that these doses are not additive because they are at different locations and occur at different points in time.							

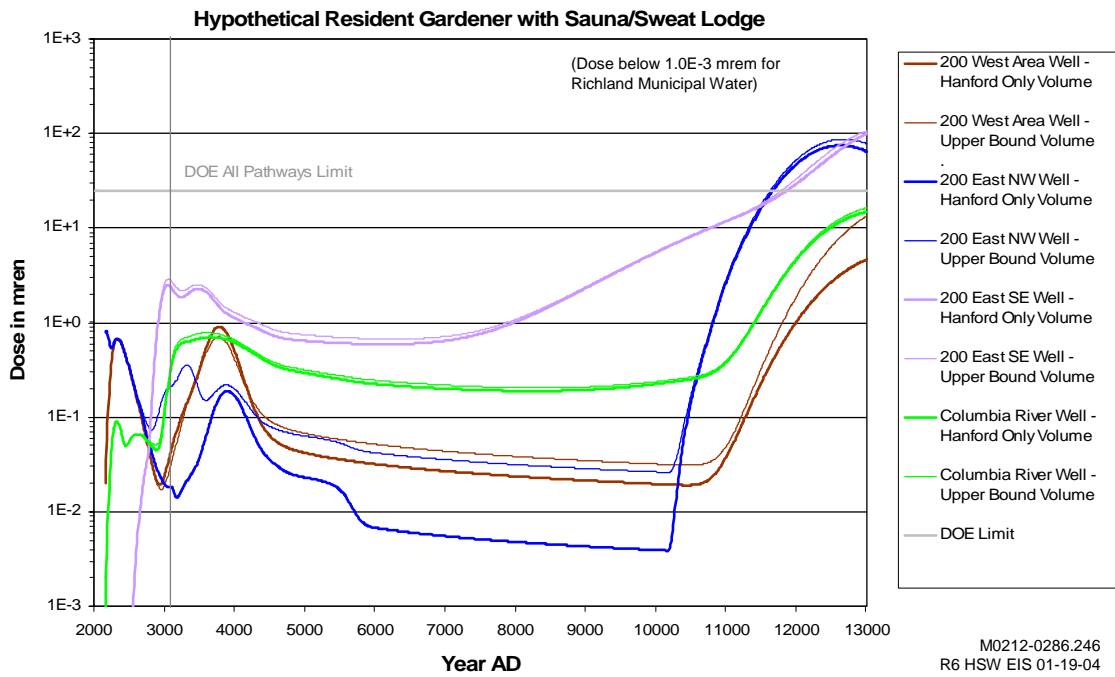
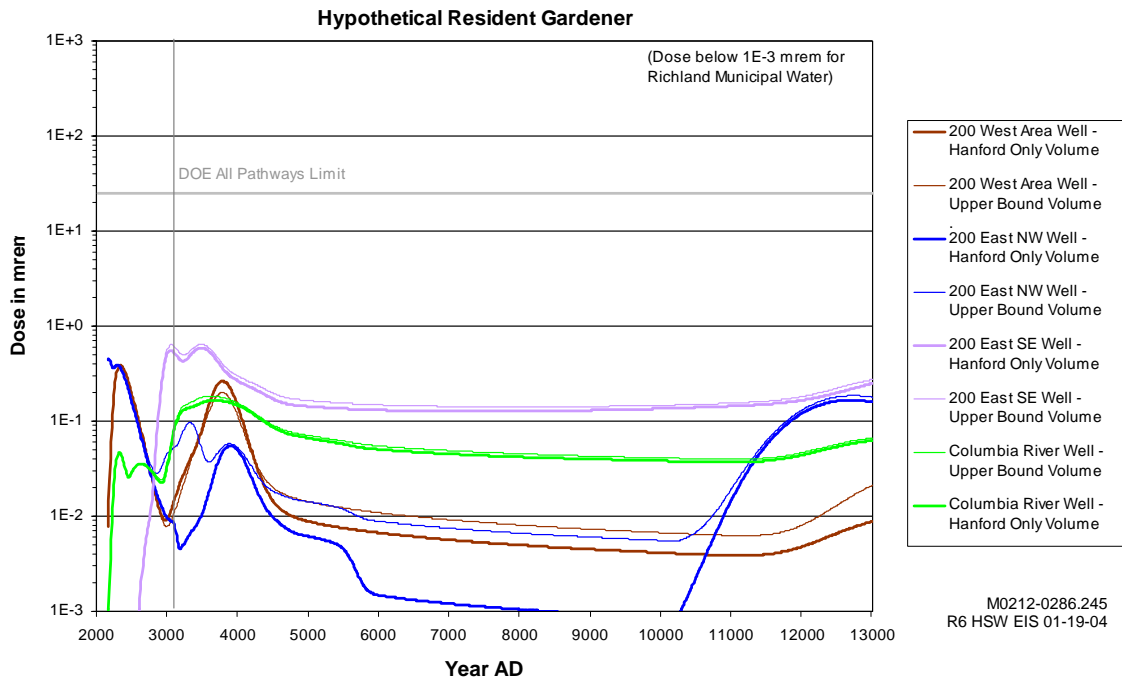
#### 5.11.2.1.4.1 Alternative Group D<sub>1</sub>

The potential consequences to the MEI are presented in Figure 5.37 for a hypothetical individual residing 1 km (0.6 mi) downgradient from disposal facilities, a hypothetical individual residing near the Columbia River, and for users of municipal water from the Richland water supply system. Results are presented for the Hanford Only and Upper Bound waste volumes. The results for the Lower Bound waste volume are nearly indistinguishable from the Hanford Only waste volume and are not displayed on the figure.

The estimated annual doses for the hypothetical resident gardener are well below the DOE all-pathway dose limit of 25 mrem/yr (DOE 2001a) for these locations within the 10,000-year timeframe. The estimated annual doses also are below the benchmark DOE drinking water dose limit of 4 mrem/yr (DOE 1993) for these locations within the 10,000-year timeframe. The results for the hypothetical resident gardener with the sauna/sweat lodge exposure pathway are below the 25-mrem annual limit within the 1000-year timeframe, but exceed the limit at later times (after about 9,000 years).

Impacts on users of Columbia River water downstream of Hanford were based on the collective population drinking water dose (2 L/day) for the Tri-Cities, Washington, population and a population the size of Portland, Oregon, and located at about that point on the Columbia River. The doses are calculated over the 10,000-year period and are presented in Table 5.99 for the Hanford Only waste volume, in Table 5.100 for the Lower Bound waste volume, and in Table 5.101 for the Upper Bound waste volume. All estimated collective radiation doses to downstream populations resulting from drinking Columbia River water are below levels expected to result in any LCFs.

The estimated annual drinking water dose for each of the groundwater points of analysis, represented as wells, are presented for comparison with the benchmark drinking water dose of 4 mrem/yr (DOE 1993). The results are presented in Tables 5.102 through 5.105 for the locations 1 km (0.6 mi) downgradient from the 200 West Area, from the 200 East Area (NW), from the 200 East Area (SE), and near the Columbia River, respectively.



**Figure 5.37.** Annual Dose to a Maximally Exposed Individual at Various Times over 10,000 Years Using Water from Various Locations – Alternative Group D<sub>1</sub>, Hanford Only and Upper Bound Waste Volumes

**Table 5.99.** Population Health Impacts from Drinking Water Downstream of Hanford over 10,000 Years – Alternative Group D<sub>1</sub>, Hanford Only Waste Volume

Waste Type	Tri-Cities, Washington		Portland, Oregon	
	Population Dose (person-rem)	Estimated Cancer Fatalities	Population Dose (person-rem)	Estimated Cancer Fatalities
Previously Disposed of	1.3E-02	0 (8E-06) <sup>(a)</sup>	3.3E-02	0 (2E-05)
Disposed of 1996–2007	1.1E-02	0 (6E-06)	2.9E-02	0 (2E-05)
Projected	1.5E-01	0 (9E-05)	4.1E-01	0 (2E-04)
Total	1.8E-01	0 (1E-04)	4.7E-01	0 (3E-04)

(a) The numbers expressed in parentheses are the calculated numbers of fatalities using the appropriate linear health effects conversion factor. The actual value must be a whole number.

**Table 5.100.** Population Health Impacts from Drinking Water Downstream of Hanford over 10,000 Years – Alternative Group D<sub>1</sub>, Lower Bound Waste Volume

Waste Type	Tri-Cities, Washington		Portland, Oregon	
	Population Dose (person-rem)	Estimated Cancer Fatalities	Population Dose (person-rem)	Estimated Cancer Fatalities
Previously Disposed of	1.3E-02	0 (8E-06) <sup>(a)</sup>	3.3E-02	0 (2E-05)
Disposed of 1996–2007	1.1E-02	0 (7E-06)	2.9E-02	0 (2E-05)
Projected	1.7E-01	0 (1E-04)	4.7E-01	0 (3E-04)
Total	2.0E-01	0 (1E-04)	5.3E-01	0 (3E-04)

(a) The numbers expressed in parentheses are the calculated numbers of fatalities using the appropriate linear health effects conversion factor. The actual value must be a whole number.

**Table 5.101.** Population Health Impacts from Drinking Water Downstream of Hanford over 10,000 Years – Alternative Group D<sub>1</sub>, Upper Bound Waste Volume

Waste Type	Tri-Cities, Washington		Portland, Oregon	
	Population Dose (person-rem)	Estimated Cancer Fatalities	Population Dose (person-rem)	Estimated Cancer Fatalities
Previously Disposed of	1.3E-02	0 (8E-06) <sup>(a)</sup>	3.3E-02	0 (2E-05)
Disposed of 1996–2007	2.0E-02	0 (1E-05)	5.3E-02	0 (3E-05)
Projected	1.8E-01	0 (1E-04)	4.7E-01	0 (3E-04)
Total	2.1E-01	0 (1E-04)	5.6E-01	0 (3E-04)

(a) The numbers expressed in parentheses are the calculated numbers of fatalities using the appropriate linear health effects conversion factor. The actual value must be a whole number.

**Table 5.102.** Maximum Annual Drinking Water Dose for a Hypothetical Well 1 km Downgradient from the 200 West Area, Alternative Group D<sub>1</sub>

Waste Volume	Radionuclide	Maximum Annual Dose	
		Dose, mrem	Years post-2046
Hanford Only	Carbon-14	0.0	Not Present
	Technetium-99	4.6E-02	1,730
	Iodine-129	1.1E-01	280
	Uranium <sup>(a)</sup>	1.1E-03	10,000
	Total	1.2E-01	280
Upper Bound	Carbon-14	0.0	Not Present
	Technetium-99	3.7E-02	1,720
	Iodine-129	1.1E-01	280
	Uranium <sup>(a)</sup>	2.0E-03	10,000
	Total	1.2E-01	280

(a) The entry for uranium includes the contributions from all uranium isotopes.

**Table 5.103.** Maximum Annual Drinking Water Dose for a Hypothetical Well 1 km Downgradient Northwest from the 200 East Area, Alternative Group D<sub>1</sub>

Waste Volume	Radionuclide	Maximum Annual Dose	
		Dose, mrem	Years post-2046
Hanford Only	Carbon-14	2.5E-03	10,000
	Technetium-99	9.6E-03	1,850
	Iodine-129	1.1E-01	120
	Uranium <sup>(a)</sup>	4.8E-02	10,000
	Total	1.1E-01	120
Upper Bound	Carbon-14	2.5E-03	10,000
	Technetium-99	1.9E-02	1,270
	Iodine-129	1.1E-01	120
	Uranium <sup>(a)</sup>	5.4E-02	10,000
	Total	1.1E-01	120

(a) The entry for uranium includes the contributions from all uranium isotopes.



**Table 5.104.** Maximum Annual Drinking Water Dose for a Hypothetical Well 1 km Downgradient Southeast from the 200 East Area, Alternative Group D<sub>1</sub>

Waste Volume	Radionuclide	Maximum Annual Dose	
		Dose, mrem	Years post-2046
Hanford Only	Carbon-14	1.0E-05	10,000
	Technetium-99	1.5E-01	1000
	Iodine-129	5.2E-02	1,450
	Uranium <sup>(a)</sup>	2.9E-02	10,000
	Total	1.8E-01	1,430
Upper Bound	Carbon-14	4.5E-05	10,000
	Technetium-99	1.7E-01	1010
	Iodine-129	5.2E-02	1,450
	Uranium <sup>(a)</sup>	3.3E-02	10,000
	Total	1.9E-01	1,430

(a) The entry for uranium includes the contributions from all uranium isotopes.

**Table 5.105.** Maximum Annual Drinking Water Dose for a Hypothetical Well Near the Columbia River, Alternative Group D<sub>1</sub>

Waste Volume	Radionuclide	Maximum Annual Dose	
		Dose, mrem	Years post-2046
Hanford Only	Carbon-14	1.2E-04	10,000
	Technetium-99	4.1E-02	1,600
	Iodine-129	1.3E-02	270
	Uranium <sup>(a)</sup>	4.7E-03	10,000
	Total	5.0E-02	1,640
Upper Bound	Carbon-14	1.2E-04	10,000
	Technetium-99	4.5E-02	1,530
	Iodine-129	1.3E-02	270
	Uranium <sup>(a)</sup>	4.9E-03	10,000
	Total	5.5E-02	1,560

(a) The entry for uranium includes the contributions from all uranium isotopes.

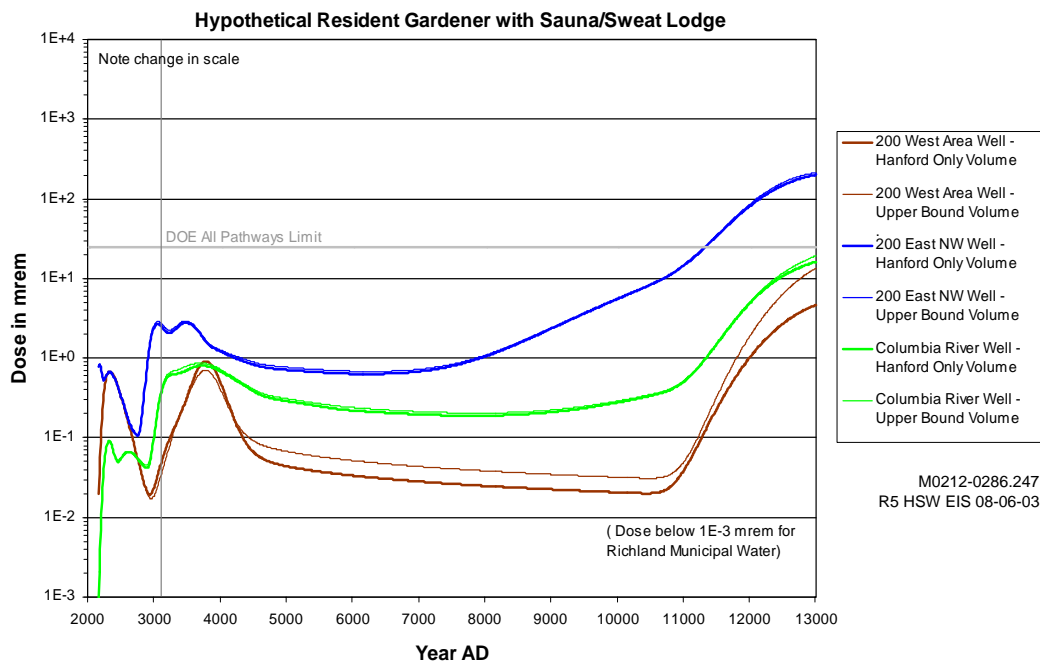
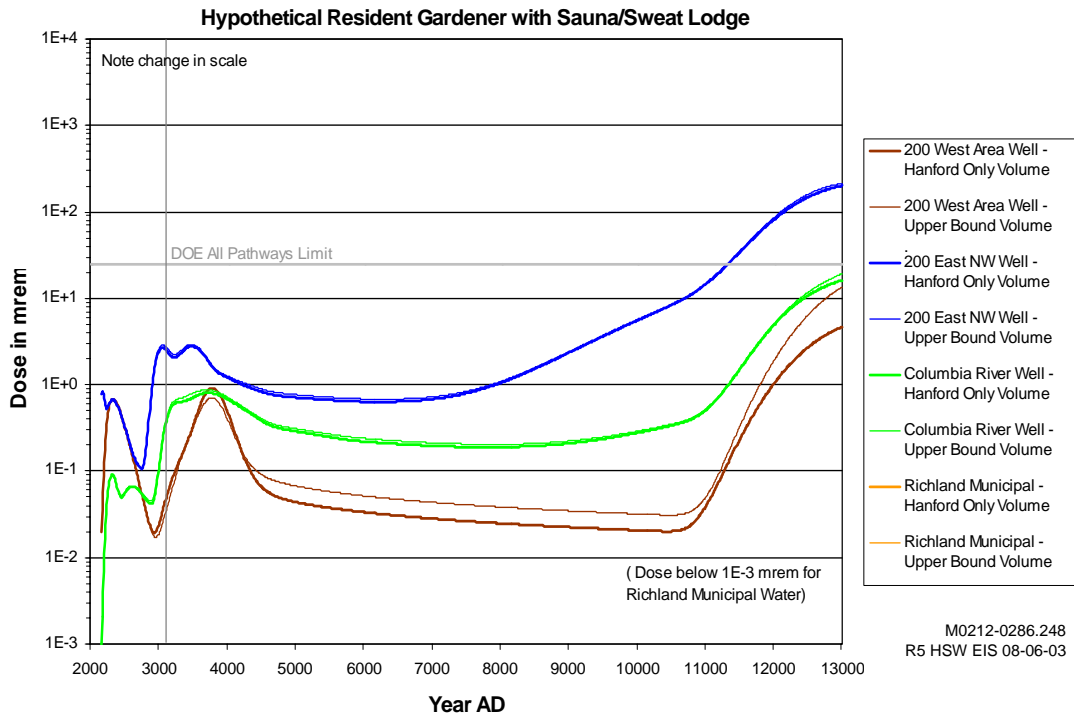
#### 5.11.2.1.4.2 Alternative Group D<sub>2</sub>

The potential consequences to the MEI are presented in Figure 5.38 for a hypothetical individual residing 1 km (0.6 mi) downgradient from disposal facilities, a hypothetical individual residing near the Columbia River, and for users of municipal water from the Richland water supply system. Results are presented for the Hanford Only and Upper Bound waste volumes. The results for the Lower Bound waste volume are nearly indistinguishable from the Hanford Only waste volume and are not displayed on the figure.

The estimated annual doses for the hypothetical resident gardener are well below the DOE all-pathway dose limit of 25 mrem/yr (DOE 2001a) for these locations within the 10,000-year timeframe. The estimated annual doses also are below the benchmark DOE drinking water dose limit of 4 mrem/yr (DOE 1993) for these locations within the 10,000-year timeframe. The results for the hypothetical resident gardener with the sauna/sweat lodge exposure pathway are below the 25-mrem annual limit within the 1000-year timeframe, but exceed the limit at later times (after about 9,000 years).

Impacts on users of Columbia River water downstream of Hanford were based on the collective population drinking water dose (2 L/day) for the Tri-Cities, Washington, population and a population the size of Portland, Oregon, and located at about that point on the Columbia River. The doses are calculated over the 10,000-year period and are presented in Table 5.106 for the Hanford Only waste volume, in Table 5.107 for the Lower Bound waste volume, and in Table 5.108 for the Upper Bound waste volume. All estimated collective radiation doses to downstream populations resulting from drinking Columbia River water are below levels expected to result in any LCFs.

The estimated annual drinking water dose for each of the groundwater points of analysis, represented as wells, are presented for comparison with the benchmark drinking water dose of 4 mrem/yr (DOE 1993). The results are presented in Tables 5.109 through 5.111 for the locations 1 km (0.6 mi) downgradient from the 200 West Area, from the 200 East Area (NW), and near the Columbia River, respectively.



**Figure 5.38.** Annual Dose to a Maximally Exposed Individual at Various Times over 10,000 Years Using Water from Various Locations – Alternative Group D<sub>2</sub>, Hanford Only and Upper Bound Waste Volumes

**Table 5.106.** Population Health Impacts from Drinking Water Downstream of Hanford over 10,000 Years – Alternative Group D<sub>2</sub>, Hanford Only Waste Volume

Waste Type	Tri-Cities, Washington		Portland, Oregon	
	Population Dose (person-rem)	Estimated Cancer Fatalities	Population Dose (person-rem)	Estimated Cancer Fatalities
Previously Disposed of	1.3E-02	0 (8E-06) <sup>(a)</sup>	3.3E-02	0 (2E-05)
Disposed of 1996–2007	1.1E-02	0 (6E-06)	2.9E-02	0 (2E-05)
Projected	1.6E-01	0 (1E-04)	4.3E-01	0 (3E-04)
Total	1.9E-01	0 (1E-04)	5.0E-01	0 (3E-04)

(a) The numbers expressed in parentheses are the calculated numbers of fatalities using the appropriate linear health effects conversion factor. The actual value must be a whole number.

**Table 5.107.** Population Health Impacts from Drinking Water Downstream of Hanford over 10,000 Years – Alternative Group D<sub>2</sub>, Lower Bound Waste Volume

Waste Type	Tri-Cities, Washington		Portland, Oregon	
	Population Dose (person-rem)	Estimated Cancer Fatalities	Population Dose (person-rem)	Estimated Cancer Fatalities
Previously Disposed of	1.3E-02	0 (8E-06) <sup>(a)</sup>	3.3E-02	0 (2E-05)
Disposed of 1996–2007	1.1E-02	0 (7E-06)	2.9E-02	0 (2E-05)
Projected	1.6E-01	0 (1E-04)	4.4E-01	0 (3E-04)
Total	1.9E-01	0 (1E-04)	5.0E-01	0 (3E-04)

(a) The numbers expressed in parentheses are the calculated numbers of fatalities using the appropriate linear health effects conversion factor. The actual value must be a whole number.

**Table 5.108.** Population Health Impacts from Drinking Water Downstream of Hanford over 10,000 Years – Alternative Group D<sub>2</sub>, Upper Bound Waste Volume

Waste Type	Tri-Cities, Washington		Portland, Oregon	
	Population Dose (person-rem)	Estimated Cancer Fatalities	Population Dose (person-rem)	Estimated Cancer Fatalities
Previously Disposed of	1.3E-02	0 (8E-06) <sup>(a)</sup>	3.3E-02	0 (2E-05)
Disposed of 1996–2007	1.7E-02	0 (1E-05)	4.6E-02	0 (3E-05)
Projected	1.7E-01	0 (1E-04)	4.5E-01	0 (3E-04)
Total	2.0E-01	0 (1E-04)	5.3E-01	0 (3E-04)

(a) The numbers expressed in parentheses are the calculated numbers of fatalities using the appropriate linear health effects conversion factor. The actual value must be a whole number.

**Table 5.109.** Maximum Annual Drinking Water Dose for a Hypothetical Well 1 km Downgradient from the 200 West Area, Alternative Group D<sub>2</sub>

Waste Volume	Radionuclide	Maximum Annual Dose	
		Dose, mrem	Years post-2046
Hanford Only	Carbon-14	0.0	Not Present
	Technetium-99	4.7E-02	1,730
	*-Iodine-129	1.1E-01	280
	Uranium <sup>(a)</sup>	1.1E-03	10,000
	Total	1.2E-01	280
Upper Bound	Carbon-14	0.0	Not Present
	Technetium-99	3.7E-02	1,720
	Iodine-129	1.1E-01	280
	Uranium <sup>(a)</sup>	2.0E-03	10,000
	Total	1.2E-01	280

(a) The entry for uranium includes the contributions from all uranium isotopes.

**Table 5.110.** Maximum Annual Drinking Water Dose for a Hypothetical Well 1 km Downgradient Northwest from the 200 East Area, Alternative Group D<sub>2</sub>

Waste Volume	Radionuclide	Maximum Annual Dose	
		Dose, mrem	Years post-2046
Hanford Only	Carbon-14	2.5E-03	10,000
	Technetium-99	1.6E-01	1000
	Iodine-129	1.1E-01	120
	Uranium <sup>(a)</sup>	8.2E-02	10,000
	Total	2.2E-01	1,440
Upper Bound	Carbon-14	2.6E-03	10,000
	Technetium-99	1.7E-01	1,010
	Iodine-129	1.1E-01	120
	Uranium <sup>(a)</sup>	8.7E-02	10,000
	Total	2.3E-01	1,430

(a) The entry for uranium includes the contributions from all uranium isotopes.

**Table 5.111.** Maximum Annual Drinking Water Dose for a Hypothetical Well Near the Columbia River, Alternative Group D<sub>2</sub>

Waste Volume	Radionuclide	Maximum Annual Dose	
		Dose, mrem	Years post-2046
Hanford Only	Carbon-14	1.2E-04	10,000
	Technetium-99	4.6E-02	1,670
	Iodine-129	1.4E-02	1,680
	Uranium <sup>(a)</sup>	4.7E-03	10,000
	Total	6.0E-02	1,670
Upper Bound	Carbon-14	1.2E-04	10,000
	Technetium-99	4.9E-02	1,650
	Iodine-129	1.5E-02	1,650
	Uranium <sup>(a)</sup>	4.9E-03	10,000
	Total	6.4E-02	1,650

(a) The entry for uranium includes the contributions from all uranium isotopes.

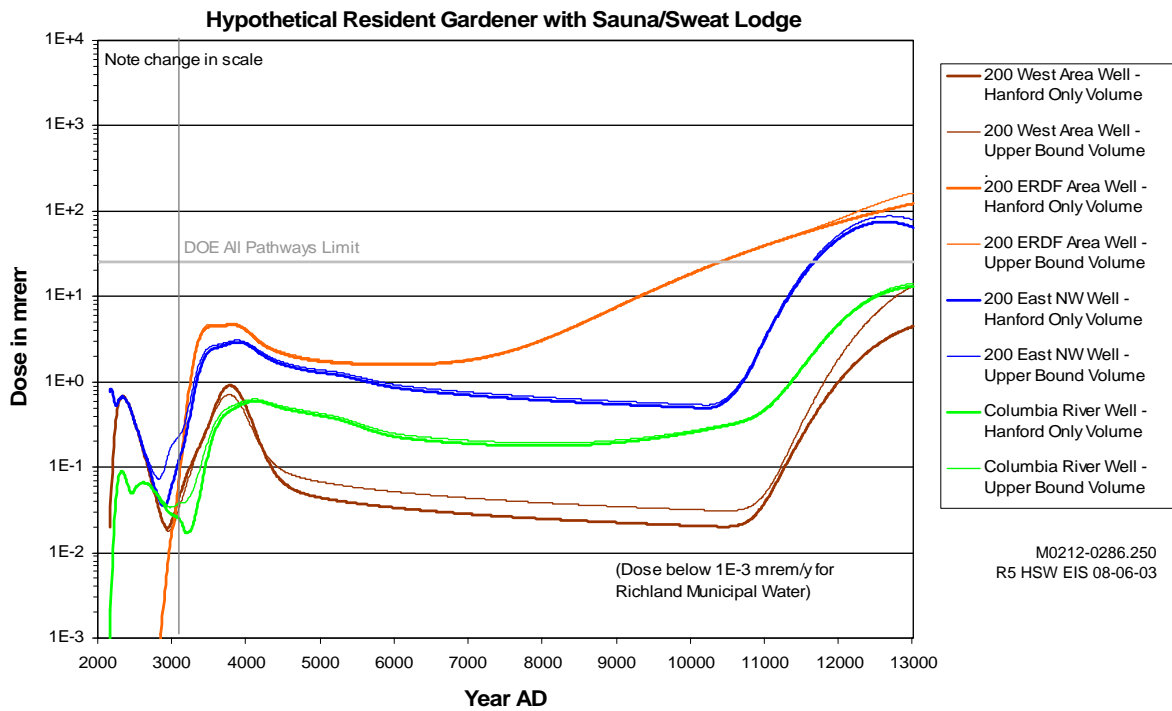
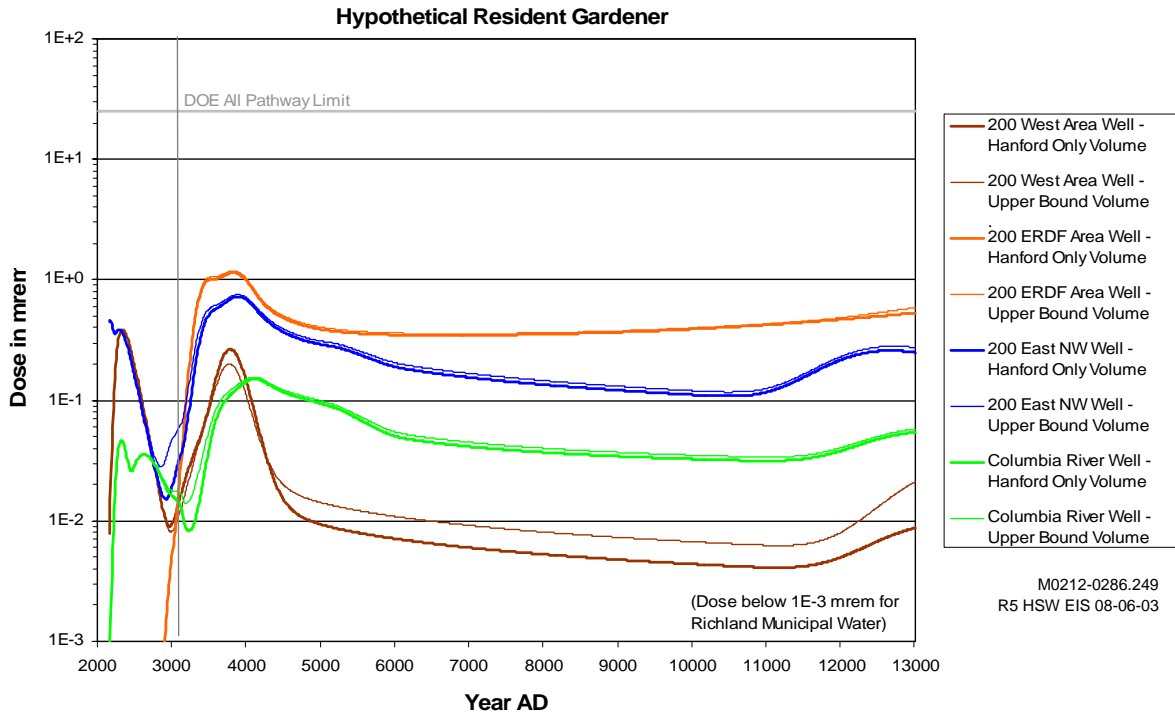
#### 5.11.2.1.4.3 Alternative Group D<sub>3</sub>

The potential consequences to the MEI are presented in Figure 5.39 for a hypothetical individual residing 1 km (0.6 mi) downgradient from disposal facilities, a hypothetical individual residing near the Columbia River, and for users of municipal water from the Richland water supply system. Results are presented for the Hanford Only and Upper Bound waste volumes. The results for the Lower Bound waste volume are nearly indistinguishable from the Hanford Only waste volume and are not displayed on the figure.

The estimated annual doses for the hypothetical resident gardener are well below the DOE all-pathway dose limit of 25 mrem/yr (DOE 2001a) for these locations within the 10,000-year timeframe. The estimated annual doses also are below the benchmark DOE drinking water dose limit of 4 mrem/yr (DOE 1993) for these locations within the 10,000-year timeframe. The results for the hypothetical resident gardener with the sauna/sweat lodge exposure pathway are below the 25-mrem annual limit within the 1000-year timeframe, but exceed the limit at later times (after about 8,000 years).

Impacts on users of Columbia River water downstream of Hanford were based on the collective population drinking water dose (2 L/day) for the Tri-Cities, Washington, population and a population the size of Portland, Oregon, and located at about that point on the Columbia River. The doses are calculated over the 10,000-year period and are presented in Table 5.112 for the Hanford Only waste volume, in Table 5.113 for the Lower Bound waste volume, and in Table 5.114 for the Upper Bound waste volume. All estimated collective radiation doses to downstream populations resulting from drinking Columbia River water are below levels expected to result in any LCFs.

The estimated annual drinking water dose for each of the groundwater points of analysis, represented as wells, are presented for comparison with the benchmark drinking water dose of 4 mrem/yr (DOE 1993). The results are presented in Tables 5.115 through 5.118 for the locations 1 km (0.6 mi) downgradient from the 200 West Area, the ERDF, the 200 East Area (NW), and near the Columbia River, respectively.



**Figure 5.39.** Annual Dose to a Maximally Exposed Individual at Various Times over 10,000 Years Using Water from Various Locations – Alternative Group D<sub>3</sub>, Hanford Only and Upper Bound Waste Volumes

**Table 5.112.** Population Health Impacts from Drinking Water Downstream of Hanford over 10,000 Years – Alternative Group D<sub>3</sub>, Hanford Only Waste Volume

Waste Type	Tri-Cities, Washington		Portland, Oregon	
	Population Dose (person-rem)	Estimated Cancer Fatalities	Population Dose (person-rem)	Estimated Cancer Fatalities
Previously Disposed of	1.3E-02	0 (8E-06) <sup>(a)</sup>	3.3E-02	0 (2E-05)
Disposed of 1996–2007	1.1E-03	0 (6E-06)	2.9E-02	0 (2E-05)
Projected	1.8E-01	0 (1E-04)	4.9E-01	0 (3E-04)
Total	2.1E-01	0 (1E-04)	5.5E-01	0 (3E-04)

(a) The numbers expressed in parentheses are the calculated numbers of fatalities using the appropriate linear health effects conversion factor. The actual value must be a whole number.

**Table 5.113.** Population Health Impacts from Drinking Water Downstream of Hanford over 10,000 Years – Alternative Group D<sub>3</sub>, Lower Bound Waste Volume

Waste Type	Tri-Cities, Washington		Portland, Oregon	
	Population Dose (person-rem)	Estimated Cancer Fatalities	Population Dose (person-rem)	Estimated Cancer Fatalities
Previously Disposed of	1.3E-02	0 (8E-06) <sup>(a)</sup>	3.3E-02	0 (2E-05)
Disposed of 1996–2007	1.1E-02	0 (7E-06)	2.9E-02	0 (2E-05)
Projected	1.8E-01	0 (1E-04)	4.9E-01	0 (3E-04)
Total	2.1E-01	0 (1E-04)	5.6E-01	0 (3E-04)

(a) The numbers expressed in parentheses are the calculated numbers of fatalities using the appropriate linear health effects conversion factor. The actual value must be a whole number.

**Table 5.114.** Population Health Impacts from Drinking Water Downstream of Hanford over 10,000 Years – Alternative Group D<sub>3</sub>, Upper Bound Waste Volume

Waste Type	Tri-Cities, Washington		Portland, Oregon	
	Population Dose (person-rem)	Estimated Cancer Fatalities	Population Dose (person-rem)	Estimated Cancer Fatalities
Previously Disposed of	1.3E-02	0 (8E-06) <sup>(a)</sup>	3.3E-02	0 (2E-05)
Disposed of 1996–2007	1.7E-02	0 (1E-05)	4.6E-02	0 (3E-05)
Projected	1.9E-01	0 (1E-04)	5.1E-01	0 (3E-04)
Total	2.2E-01	0 (1E-04)	5.9E-01	0 (4E-04)

(a) The numbers expressed in parentheses are the calculated numbers of fatalities using the appropriate linear health effects conversion factor. The actual value must be a whole number.



**Table 5.115.** Maximum Annual Drinking Water Dose for a Hypothetical Well 1 km Downgradient from the 200 West Area, Alternative Group D<sub>3</sub>

Waste Volume	Radionuclide	Maximum Annual Dose	
		Dose, mrem	Years post-2046
Hanford Only	Carbon-14	0.0	Not Present
	Technetium-99	4.7E-02	1,730
	Iodine-129	1.1E-01	280
	Uranium <sup>(a)</sup>	1.1E-03	Not Present
	Total	1.2E-01	280
Upper Bound	Carbon-14	0.0	Not Present
	Technetium-99	3.7E-02	1,720
	Iodine-129	1.1E-01	280
	Uranium <sup>(a)</sup>	2.0E-03	10,000
	Total	1.2E-01	280

(a) The entry for uranium includes the contributions from all uranium isotopes.

**Table 5.116.** Maximum Annual Drinking Water Dose for a Hypothetical Well 1 km Downgradient from the ERDF Site, Alternative Group D<sub>3</sub>

Waste Volume	Radionuclide	Maximum Annual Dose	
		Dose, mrem	Years post-2046
Hanford Only	Carbon-14	0.0	Not Present
	Technetium-99	2.7E-01	1,470
	Iodine-129	8.2E-02	1,810
	Uranium <sup>(a)</sup>	7.1E-02	10,000
	Total	3.4E-01	1,780
Upper Bound	Carbon-14	0.0	Not Present
	Technetium-99	2.8E-01	1,470
	Iodine-129	8.3E-02	1,810
	Uranium <sup>(a)</sup>	7.9E-02	10,000
	Total	3.6E-01	1,780

(a) The entry for uranium includes the contributions from all uranium isotopes.

**Table 5.117.** Maximum Annual Drinking Water Dose for a Hypothetical Well 1 km Downgradient Northwest from the 200 East Area, Alternative Group D<sub>3</sub>

Waste Volume	Radionuclide	Maximum Annual Dose	
		Dose, mrem	Years post-2046
Hanford Only	Carbon-14	2.5E-03	10,000
	Technetium-99	1.7E-01	1,820
	Iodine-129	1.1E-01	120
	Uranium <sup>(a)</sup>	4.8E-02	10,000
	Total	2.2E-01	1,840
Upper Bound	Carbon-14	2.5E-03	10,000
	Technetium-99	1.7E-01	1,810
	Iodine-129	1.1E-01	120
	Uranium <sup>(a)</sup>	5.4E-02	10,000
	Total	2.3E-01	1,840

(a) The entry for uranium includes the contributions from all uranium isotopes.

**Table 5.118.** Maximum Annual Drinking Water Dose for a Hypothetical Well Near the Columbia River, Alternative Group D<sub>3</sub>

Waste Volume	Radionuclide	Maximum Annual Dose	
		Dose, mrem	Years post-2046
Hanford Only	Carbon-14	1.2E-04	10,000
	Technetium-99	3.4E-02	2,080
	Iodine-129	1.3E-02	270
	Uranium <sup>(a)</sup>	4.6E-03	10,000
	Total	4.5E-02	2,070
Upper Bound	Carbon-14	1.2E-04	10,000
	Technetium-99	3.5E-02	2,070
	Iodine-129	1.3E-02	270
	Uranium <sup>(a)</sup>	4.7E-03	10,000
	Total	4.7E-02	2,070

(a) The entry for uranium includes the contributions from all uranium isotopes.

### 5.11.2.1.5 Alternative Group E

There are three subalternatives considered for Alternative Group E with variations on disposal options for the waste streams. See Section 5.0 for a summary of the characteristics for the three subalternatives (E<sub>1</sub>, E<sub>2</sub>, and E<sub>3</sub>) to this alternative group.

#### 5.11.2.1.5.1 Alternative Group E<sub>1</sub>

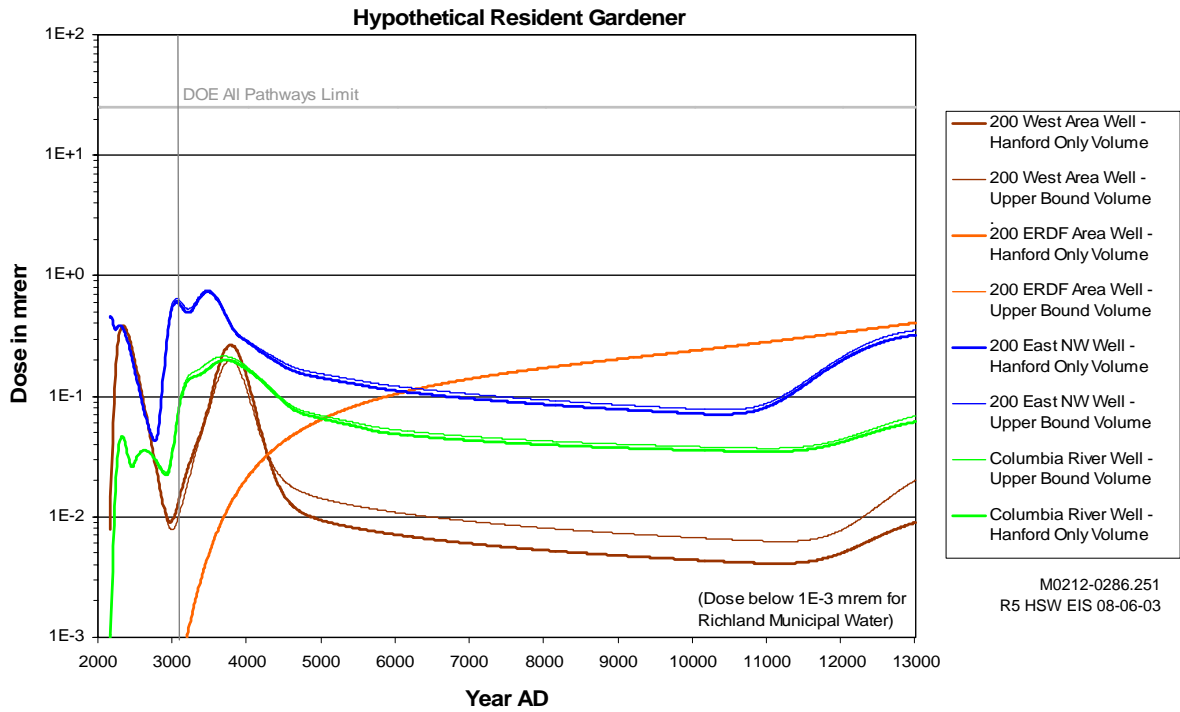
The potential consequences to the MEI are presented in Figure 5.40 for a hypothetical individual residing 1 km (0.6 mi) downgradient from disposal facilities, a hypothetical individual residing near the Columbia River, and for users of municipal water from the Richland water supply system. Results are

presented for the Hanford Only and Upper Bound waste volumes. The results for the Lower Bound waste volume are nearly indistinguishable from the Hanford Only waste volume and are not displayed on the figure.

The estimated annual doses for the hypothetical resident gardener are well below the DOE all-pathway dose limit of 25 mrem/yr (DOE 2001a) for these locations within the 10,000-year timeframe. The estimated annual doses also are below the benchmark DOE drinking water dose limit of 4 mrem/yr (DOE 1993) for these locations within the 10,000-year timeframe. The results for the hypothetical resident gardener with the sauna/sweat lodge exposure pathway are below the 25-mrem annual limit within the 1000-year timeframe, but exceed the limit at later times (after about 8,000 years).

Impacts on users of Columbia River water downstream of Hanford were based on the collective population drinking water dose (2 L/day) for the Tri-Cities, Washington, population and a population the size of Portland, Oregon, and located at about that point on the Columbia River. The doses are calculated over the 10,000-year period and are presented in Table 5.119 for the Hanford Only waste volume, in Table 5.120 for the Lower Bound waste volume, and in Table 5.121 for the Upper Bound waste volume. All estimated collective radiation doses to downstream populations resulting from drinking Columbia River water are below levels expected to result in any LCFs.

The estimated annual drinking water dose for each of the groundwater points of analysis, represented as wells, are presented for comparison with the benchmark drinking water dose of 4 mrem/yr (DOE 1993). The results are presented in Tables 5.122 through 5.125 for the locations 1 km (0.6 mi) downgradient from the 200 West Area, the ERDF, the 200 East Area (NW), and near the Columbia River, respectively.



**Figure 5.40.** Annual Dose to a Maximally Exposed Individual at Various Times over 10,000 Years Using Water from Various Locations – Alternative Group E<sub>1</sub>, Hanford Only and Lower Bound Waste Volumes

**Table 5.119.** Population Health Impacts from Drinking Water Downstream of Hanford over 10,000 Years – Alternative Group E<sub>1</sub>, Hanford Only Waste Volume

Waste Type	Tri-Cities, Washington		Portland, Oregon	
	Population Dose (person-rem)	Estimated Cancer Fatalities	Population Dose (person-rem)	Estimated Cancer Fatalities
Previously Disposed of	1.3E-02	0 (8E-06) <sup>(a)</sup>	3.3E-02	0 (2E-05)
Disposed of 1996–2007	1.1E-02	0 (6E-06)	2.9E-02	0 (2E-05)
Projected	1.6E-01	0 (1E-04)	4.4E-01	0 (3E-04)
Total	1.9E-01	0 (1E-04)	5.0E-01	0 (3E-04)

(a) The numbers expressed in parentheses are the calculated numbers of fatalities using the appropriate linear health effects conversion factor. The actual value must be a whole number.

**Table 5.120.** Population Health Impacts from Drinking Water Downstream of Hanford over 10,000 Years – Alternative Group E<sub>1</sub>, Lower Bound Waste Volume

Waste Type	Tri-Cities, Washington		Portland, Oregon	
	Population Dose (person-rem)	Estimated Cancer Fatalities	Population Dose (person-rem)	Estimated Cancer Fatalities
Previously Disposed of	1.3E-02	0 (8E-06) <sup>(a)</sup>	3.3E-02	0 (2E-05)
Disposed of 1996–2007	1.1E-02	0 (7E-06)	2.9E-02	0 (2E-05)
Projected	1.6E-01	0 (1E-04)	4.4E-01	0 (3E-04)
Total	1.9E-01	0 (1E-04)	5.0E-01	0 (3E-04)

(a) The numbers expressed in parentheses are the calculated numbers of fatalities using the appropriate linear health effects conversion factor. The actual value must be a whole number.

**Table 5.121.** Population Health Impacts from Drinking Water Downstream of Hanford over 10,000 Years – Alternative Group E<sub>1</sub>, Upper Bound Waste Volume

Waste Type	Tri-Cities, Washington		Portland, Oregon	
	Population Dose (person-rem)	Estimated Cancer Fatalities	Population Dose (person-rem)	Estimated Cancer Fatalities
Previously Disposed of	1.3E-02	0 (8E-06) <sup>(a)</sup>	3.3E-02	0 (2E-05)
Disposed of 1996–2007	1.7E-02	0 (1E-05)	4.6E-02	0 (3E-05)
Projected	1.7E-01	0 (1E-04)	4.5E-01	0 (3E-04)
Total	2.0E-01	0 (1E-04)	5.3E-01	0 (3E-04)

(a) The numbers expressed in parentheses are the calculated numbers of fatalities using the appropriate linear health effects conversion factor. The actual value must be a whole number.

**Table 5.122.** Maximum Annual Drinking Water Dose for a Hypothetical Well 1 km Downgradient from the 200 West Area, Alternative Group E<sub>1</sub>

Waste Volume	Radionuclide	Maximum Annual Dose	
		Dose, mrem	Years post-2046
Hanford Only	Carbon-14	0.0	Not Present
	Technetium-99	4.7E-02	1,730
	Iodine-129	1.1E-01	280
	Uranium <sup>(a)</sup>	1.1E-03	10,000
	Total	1.2E-01	280
Upper Bound	Carbon-14	0.0	Not Present
	Technetium-99	3.7E-02	1,720
	Iodine-129	1.1E-01	280
	Uranium <sup>(a)</sup>	1.8E-03	10,000
	Total	1.2E-01	280

(a) The entry for uranium includes the contributions from all uranium isotopes.

**Table 5.123.** Maximum Annual Drinking Water Dose for a Hypothetical Well 1 km Downgradient from the ERDF Site, Alternative Group E<sub>1</sub>

Waste Volume	Radionuclide	Maximum Annual Dose	
		Dose, mrem	Years post-2046
Hanford Only	Carbon-14	0.0	Not Present
	Technetium-99	6.5E-02	10,000
	Iodine-129	1.1E-01	10,000
	Uranium <sup>(a)</sup>	7.1E-02	10,000
	Total	1.5E-01	10,000
Upper Bound	Carbon-14	0.0	Not Present
	Technetium-99	6.5E-02	10,000
	Iodine-129	1.1E-02	10,000
	Uranium <sup>(a)</sup>	7.1E-02	10,000
	Total	1.5E-01	10,000

(a) The entry for uranium includes the contributions from all uranium isotopes.

**Table 5.124.** Maximum Annual Drinking Water Dose for a Hypothetical Well 1 km Downgradient Northwest from the 200 East Area, Alternative Group E<sub>1</sub>

Waste Volume	Radionuclide	Maximum Annual Dose	
		Dose, mrem	Years post-2046
Hanford Only	Carbon-14	2.5E-03	10,000
	Technetium-99	1.6E-01	1,000
	Iodine-129	1.1E-01	120
	Uranium <sup>(a)</sup>	6.1E-02	10,000
	Total	2.2E-01	1,420
Upper Bound	Carbon-14	2.6E-03	10,000
	Technetium-99	1.8E-01	1,010
	Iodine-129	1.1E-01	120
	Uranium <sup>(a)</sup>	7.2E-02	10,000
	Total	2.4E-01	1,400

(a) The entry for uranium includes the contributions from all uranium isotopes.

**Table 5.125.** Maximum Annual Drinking Water Dose for a Hypothetical Well Near the Columbia River, Alternative Group E<sub>1</sub>

Waste Volume	Radionuclide	Maximum Annual Dose	
		Dose, mrem	Years post-2046
Hanford Only	Carbon-14	1.2E-04	10,000
	Technetium-99	4.5E-02	1,660
	Iodine-129	1.4E-02	1,670
	Uranium <sup>(a)</sup>	4.7E-03	10,000
	Total	6.0E-02	1,670
Upper Bound	Carbon-14	1.2E-04	10,000
	Technetium-99	4.9E-02	1,640
	Iodine-129	1.5E-02	1,640
	Uranium <sup>(a)</sup>	5.0E-02	10,000
	Total	6.4E-02	1,640

(a) The entry for uranium includes the contributions from all uranium isotopes.

#### 5.11.2.1.5.2 Alternative Group E<sub>2</sub>

The potential consequences to the MEI are presented in Figure 5.41 for a hypothetical individual residing 1 km (0.6 mi) downgradient from the disposal facilities, a hypothetical individual residing near the Columbia River, and for users of municipal water from the Richland water supply system. Results are presented for the Hanford Only and Upper Bound waste volumes. The results for the Lower Bound waste volume are nearly indistinguishable from the Hanford Only waste volume and are not displayed on the figure.

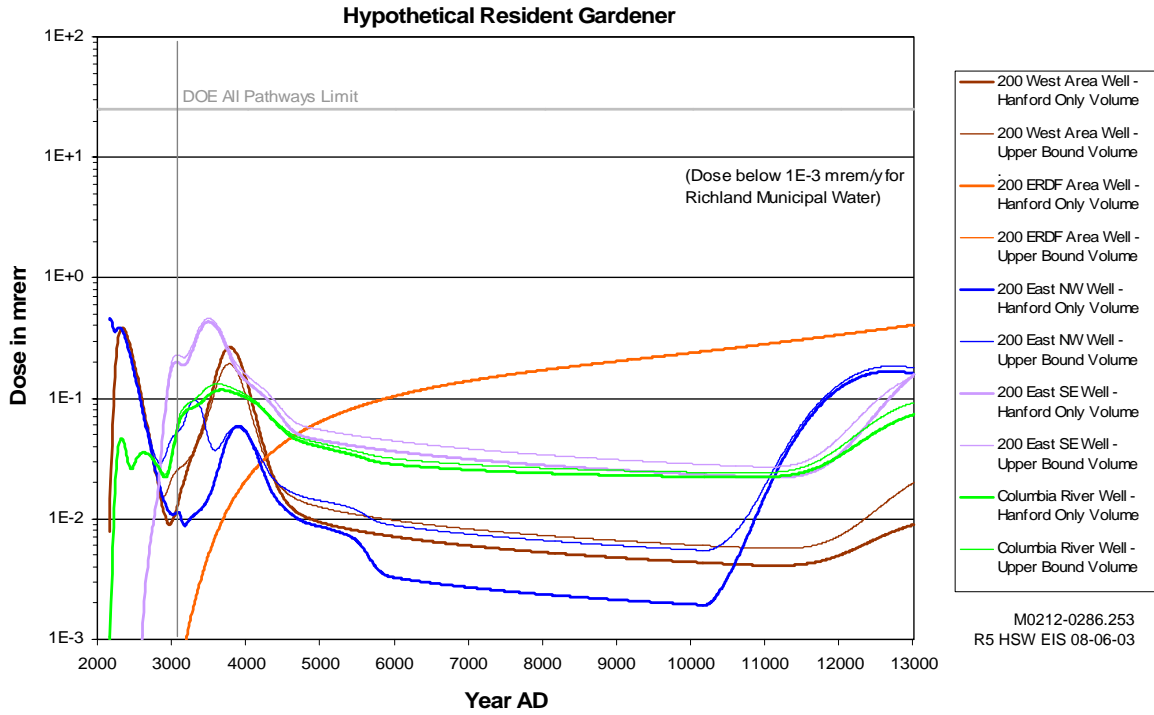
The estimated annual doses for the hypothetical resident gardener are well below the DOE all-pathway dose limit of 25 mrem/yr (DOE 2001a) for these locations within the 10,000-year timeframe. The estimated annual doses also are below the benchmark DOE drinking water dose limit of 4 mrem/yr

(DOE 1993) for these locations within the 10,000-year timeframe. The results for the hypothetical resident gardener with the sauna/sweat lodge exposure pathway are below the 25-mrem annual limit within the 1000-year timeframe, but exceed the limit at later times (after about 8,000 years).

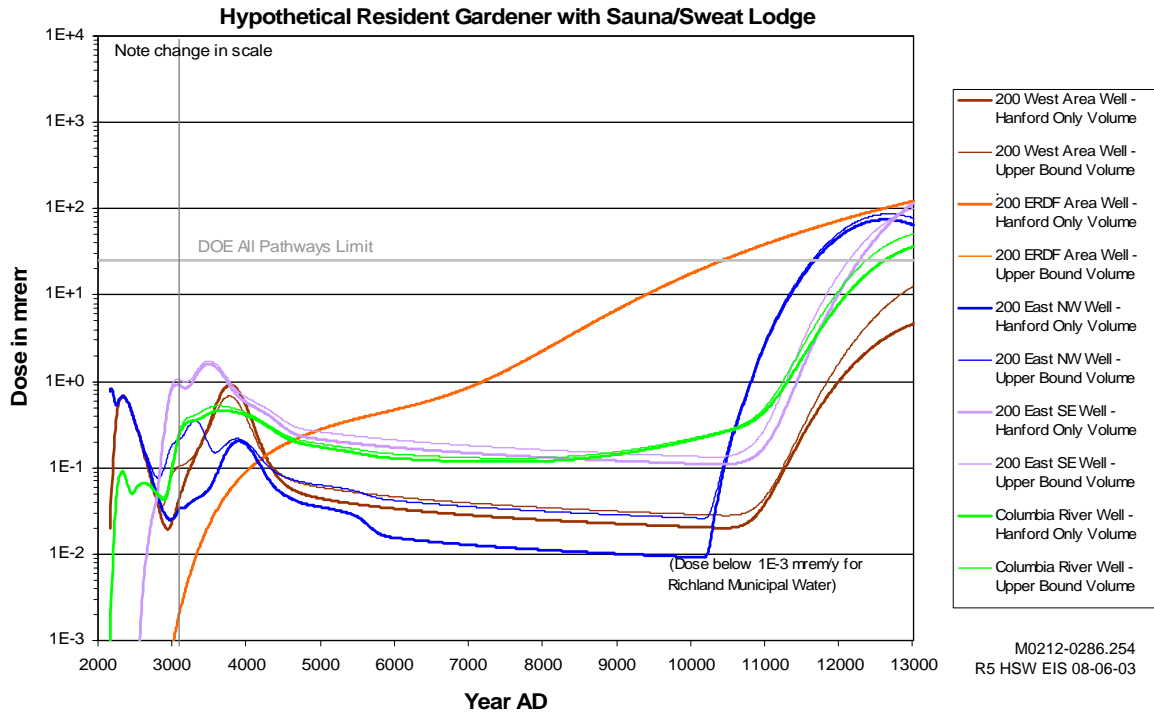
Impacts on users of Columbia River water downstream of Hanford were based on the collective population drinking water dose (2 L/days) for the Tri-Cities, Washington, population and a population the size of Portland, Oregon, and located at about that point on the Columbia River. The doses are calculated over the 10,000-year period and are presented in Table 5.126 for the Hanford Only waste volume, in Table 5.127 for the Lower Bound waste volume, and in Table 5.128 for the Upper Bound waste volume. All estimated collective radiation doses to downstream populations resulting from drinking Columbia River water are below levels expected to result in any LCFs.

The estimated annual drinking water dose for each of the groundwater points of analysis, represented as wells, are presented for comparison with the benchmark drinking water dose of 4 mrem/yr (DOE 1993). The results are presented in Tables 5.129 through 5.133 for the locations 1 km (0.6 mi) downgradient from the 200 West Area, the ERDF, the 200 East Area (NW), the 200 East Area (SE), and near the Columbia River, respectively.





M0212-0286.253  
R5 HSW EIS 08-06-03



M0212-0286.254  
R5 HSW EIS 08-06-03

**Figure 5.41.** Annual Dose to a Maximally Exposed Individual at Various Times over 10,000 Years Using Water from Various Locations – Alternative Group E<sub>2</sub>, Hanford Only and Upper Bound Waste Volumes

**Table 5.126.** Population Health Impacts from Drinking Water Downstream of Hanford over 10,000 Years – Alternative Group E<sub>2</sub>, Hanford Only Waste Volume

Waste Type	Tri-Cities, Washington		Portland, Oregon	
	Population Dose (person-rem)	Estimated Cancer Fatalities	Population Dose (person-rem)	Estimated Cancer Fatalities
Previously Disposed of	1.3E-02	0 (8E-06) <sup>(a)</sup>	3.3E-02	0 (2E-05)
Disposed of 1996–2007	1.1E-02	0 (6E-06)	2.9E-02	0 (2E-05)
Projected	1.5E-01	0 (9E-05)	4.1E-01	0 (2E-04)
Total	1.8E-01	0 (1E-04)	4.8E-01	0 (3E-04)

(a) The numbers expressed in parentheses are the calculated numbers of fatalities using the appropriate linear health effects conversion factor. The actual value must be a whole number.

**Table 5.127.** Population Health Impacts from Drinking Water Downstream of Hanford over 10,000 Years – Alternative Group E<sub>2</sub>, Lower Bound Waste Volume

Waste Type	Tri-Cities, Washington		Portland, Oregon	
	Population Dose (person-rem)	Estimated Cancer Fatalities	Population Dose (person-rem)	Estimated Cancer Fatalities
Previously Disposed of	1.3E-02	0 (8E-06) <sup>(a)</sup>	3.3E-02	0 (2E-05)
Disposed of 1996–2007	1.1E-02	0 (7E-06)	2.9E-02	0 (2E-05)
Projected	1.5E-01	0 (9E-05)	4.2E-01	0 (2E-04)
Total	1.8E-01	0 (1E-04)	4.8E-01	0 (3E-04)

(a) The numbers expressed in parentheses are the calculated numbers of fatalities using the appropriate linear health effects conversion factor. The actual value must be a whole number.

**Table 5.128.** Population Health Impacts from Drinking Water Downstream of Hanford over 10,000 Years – Alternative Group E<sub>2</sub>, Upper Bound Waste Volume

Waste Type	Tri-Cities, Washington		Portland, Oregon	
	Population Dose (person-rem)	Estimated Cancer Fatalities	Population Dose (person-rem)	Estimated Cancer Fatalities
Previously Disposed of	1.3E-02	0 (8E-06) <sup>(a)</sup>	3.3E-02	0 (2E-05)
Disposed of 1996–2007	1.7E-02	0 (1E-05)	4.6E-02	0 (3E-05)
Projected	1.6E-01	0 (1E-04)	4.3E-01	0 (3E-04)
Total	1.9E-01	0 (1E-04)	5.1E-01	0 (3E-04)

(a) The numbers expressed in parentheses are the calculated numbers of fatalities using the appropriate linear health effects conversion factor. The actual value must be a whole number.

**Table 5.129.** Maximum Annual Drinking Water Dose for a Hypothetical Well 1 km Downgradient from the 200 West Area, Alternative Group E<sub>2</sub>

Waste Volume	Radionuclide	Maximum Annual Dose	
		Dose, mrem	Years post-2046
Hanford Only	Carbon-14	0.0	Not Present
	Technetium-99	4.7E-02	1,730
	Iodine-129	1.1E-01	280
	Uranium <sup>(a)</sup>	1.1E-03	10,000
	Total	1.2E-01	280
Upper Bound	Carbon-14	0.0	Not Present
	Technetium-99	3.7E-02	1,710
	Iodine-129	1.1E-01	280
	Uranium <sup>(a)</sup>	1.8E-03	10,000
	Total	1.2E-02	280

(a) The entry for uranium includes the contributions from all uranium isotopes.

**Table 5.130.** Maximum Annual Drinking Water Dose for a Hypothetical Well 1 km Downgradient from the ERDF Site, Alternative Group E<sub>2</sub>

Waste Volume	Radionuclide	Maximum Annual Dose	
		Dose, mrem	Years post-2046
Hanford Only	Carbon-14	0.0	Not Present
	Technetium-99	6.5E-02	10,000
	Iodine-129	1.1E-02	10,000
	Uranium <sup>(a)</sup>	7.1E-02	10,000
	Total	1.5E-01	10,000
Upper Bound	Carbon-14	0.0	Not Present
	Technetium-99	6.5E-02	10,000
	Iodine-129	1.1E-02	10,000
	Uranium <sup>(a)</sup>	7.1E-02	10,000
	Total	1.5E-01	10,000

(a) The entry for uranium includes the contributions from all uranium isotopes.

**Table 5.131.** Maximum Annual Drinking Water Dose for a Hypothetical Well 1 km Downgradient Northwest from the 200 East Area, Alternative Group E<sub>2</sub>

Waste Volume	Radionuclide	Maximum Annual Dose	
		Dose, mrem	Years post-2046
Hanford Only	Carbon-14	2.5E-03	10,000
	Technetium-99	1.1E-02	1,840
	Iodine-129	1.1E-01	120
	Uranium <sup>(a)</sup>	4.8E-02	10,000
	Total	1.1E-01	120
Upper Bound	Carbon-14	2.5E-03	10,000
	Technetium-99	1.9E-02	1,260
	Iodine-129	1.1E-01	120
	Uranium <sup>(a)</sup>	5.4E-02	10,000
	Total	1.1E-01	120

(a) The entry for uranium includes the contributions from all uranium isotopes.

**Table 5.132.** Maximum Annual Drinking Water Dose for a Hypothetical Well 1 km Downgradient Southeast from the 200 East Area, Alternative Group E<sub>2</sub>

Waste Volume	Radionuclide	Maximum Annual Dose	
		Dose, mrem	Years post-2046
Hanford Only	Carbon-14	9.1E-05	10,000
	Technetium-99	1.8E-01	1,410
	Iodine-129	5.6E-02	1,450
	Uranium <sup>(a)</sup>	1.2E-02	10,000
	Total	2.3E-01	1,430
Upper Bound	Carbon-14	4.5E-05	10,000
	Technetium-99	1.9E-01	1,060
	Iodine-129	5.6E-02	1,450
	Uranium <sup>(a)</sup>	1.9E-02	10,000
	Total	2.4E-01	1,430

(a) The entry for uranium includes the contributions from all uranium isotopes.

**Table 5.133.** Maximum Annual Drinking Water Dose for a Hypothetical Well Near the Columbia River, Alternative Group E<sub>2</sub>

Volume Case	Radionuclide	Maximum Annual Dose	
		Dose, mrem	Years post-2046
Hanford Only	Carbon-14	1.2E-04	10,000
	Technetium-99	2.6E-02	1,630
	Iodine-129	1.3E-02	270
	Uranium <sup>(a)</sup>	4.7E-03	10,000
	Total	3.5E-02	1,620
Upper Bound	Carbon-14	1.2E-04	10,000
	Technetium-99	2.9E-02	1,580
	Iodine-129	1.3E-02	270
	Uranium <sup>(a)</sup>	5.0E-03	10,000
	Total	4.0E-02	1,570

(a) The entry for uranium includes the contributions from all uranium isotopes.

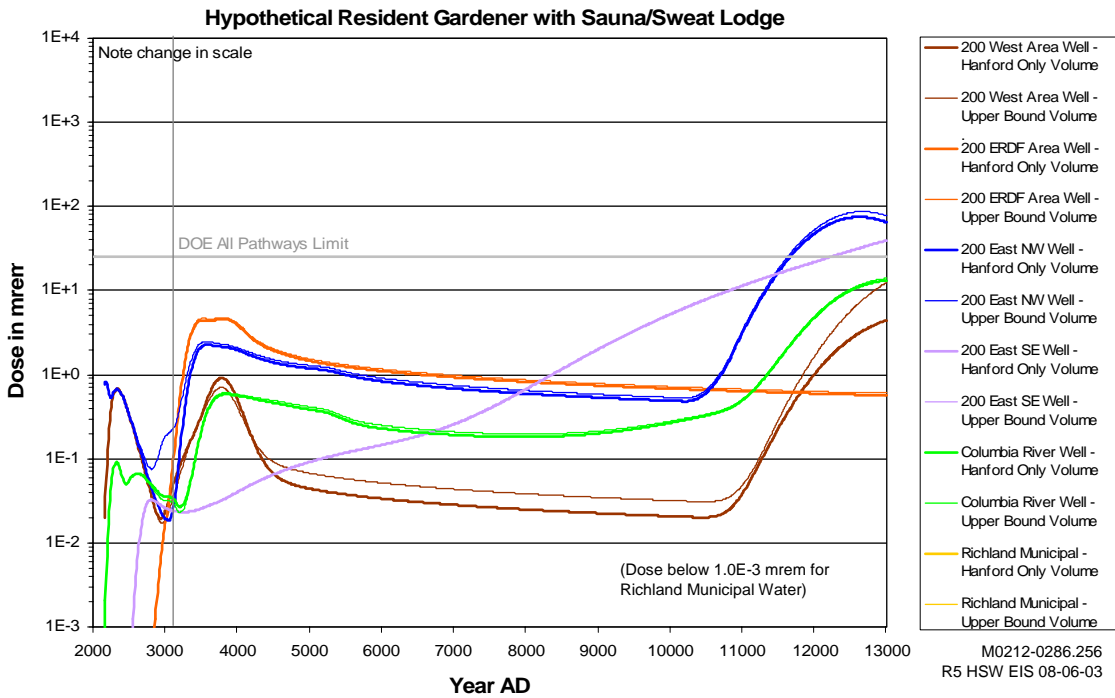
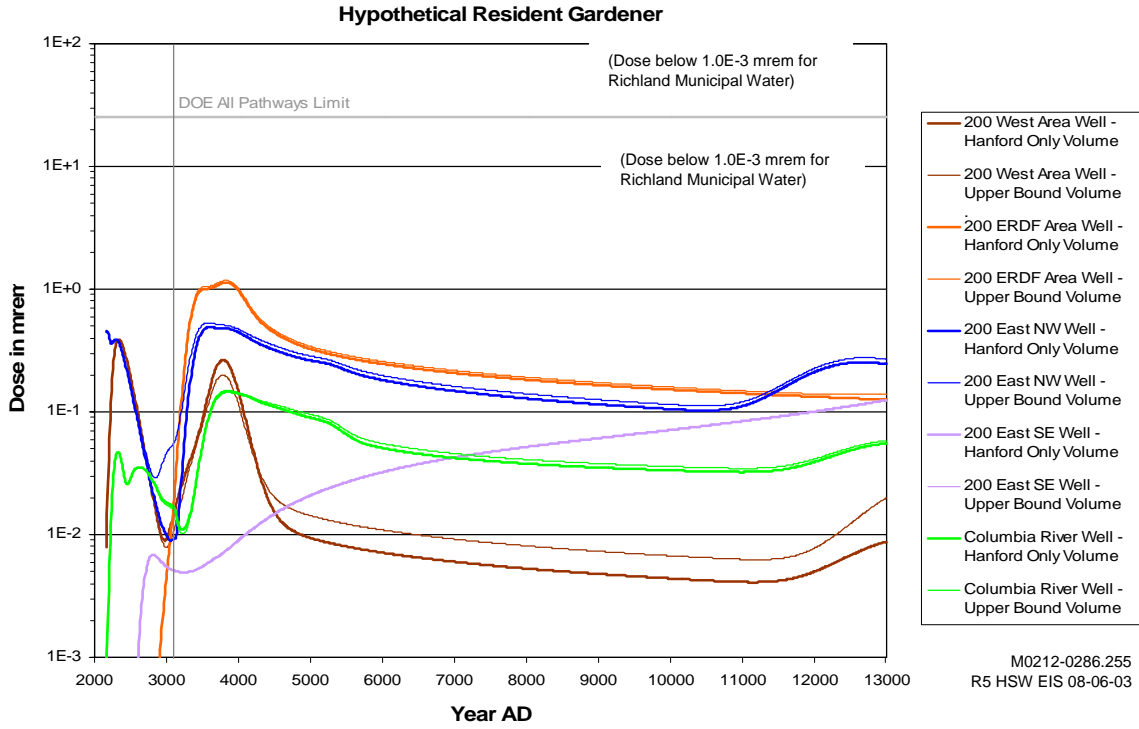
### 5.11.2.1.5.3 Alternative Group E<sub>3</sub>

The potential consequences to the MEI are presented in Figure 5.42 for a hypothetical individual residing 1 km (0.6 mi) downgradient from disposal facilities, a hypothetical individual residing near the Columbia River, and for users of municipal water from the Richland water supply system. Results are presented for the Hanford Only and Upper Bound waste volumes. The results for the Lower Bound waste volume are nearly indistinguishable from the Hanford Only waste volume and are not displayed on the figure.

The estimated annual doses for the hypothetical resident gardener are well below the DOE dose limit of 25 mrem/yr (DOE 2001a) for these locations within the 10,000-year timeframe. The estimated annual doses also are below the benchmark DOE drinking water dose limit of 4 mrem/yr (DOE 1993) for these locations within the 10,000-year timeframe. The results for the hypothetical resident gardener with the sauna/sweat lodge exposure pathway are below the 25-mrem annual limit within the 1000-year timeframe, but exceed the limit at later times (after about 9,000 years).

Impacts on users of Columbia River water downstream of Hanford were based on the collective population drinking water dose (2 L/day) for the Tri-Cities, Washington, population and a population the size of Portland, Oregon, and located at about that point on the Columbia River. The doses are calculated over the 10,000-year period and are presented in Table 5.134 for the Hanford Only waste volume, in Table 5.135 for the Lower Bound waste volume, and in Table 5.136 for the Upper Bound waste volume. All estimated collective radiation doses to downstream populations resulting from drinking Columbia River water are below levels expected to result in any LCFs.

The estimated annual drinking water dose for each of the groundwater points of analysis, represented as wells, are presented for comparison with the benchmark drinking water dose of 4 mrem/yr (DOE 1993). The results are presented in Tables 5.137 through 5.141 for the locations 1 km (0.6 mi) downgradient from the 200 West Area, the ERDF site, the 200 East Area (NW), the 200 East Area (SE), and near the Columbia River, respectively.



**Figure 5.42.** Annual Dose to a Maximally Exposed Individual at Various Times over 10,000 Years Using Water from Various Locations – Alternative Group E<sub>3</sub>, Hanford Only and Upper Bound Waste Volumes

**Table 5.134.** Population Health Impacts from Drinking Water Downstream of Hanford over 10,000 Years – Alternative Group E<sub>3</sub>, Hanford Only Waste Volume

Waste Type	Tri-Cities, Washington		Portland, Oregon	
	Population Dose (person-rem)	Estimated Cancer Fatalities	Population Dose (person-rem)	Estimated Cancer Fatalities
Previously Disposed of	1.3E-02	0 (8E-06) <sup>(a)</sup>	3.3E-02	0 (2E-05)
Disposed of 1996–2007	1.1E-02	0 (6E-06)	2.9E-02	0 (2E-05)
Projected	1.8E-01	0 (1E-04)	4.9E-01	0 (3E-04)
Total	2.1E-01	0 (1E-04)	5.5E-01	0 (3E-04)

(a) The numbers expressed in parentheses are the calculated numbers of fatalities using the appropriate linear health effects conversion factor. The actual value must be a whole number.

**Table 5.135.** Population Health Impacts from Drinking Water Downstream of Hanford over 10,000 Years – Alternative Group E<sub>3</sub>, Lower Bound Waste Volume

Waste Type	Tri-Cities, Washington		Portland, Oregon	
	Population Dose (person-rem)	Estimated Cancer Fatalities	Population Dose (person-rem)	Estimated Cancer Fatalities
Previously Disposed of	1.3E-02	0 (8E-06) <sup>(a)</sup>	3.3E-02	0 (2E-05)
Disposed of 1996–2007	1.1E-02	0 (7E-06)	2.9E-02	0 (2E-05)
Projected	1.8E-01	0 (1E-04)	4.9E-01	0 (3E-04)
Total	2.1E-01	0 (1E-04)	5.5E-01	0 (3E-04)

(a) The numbers expressed in parentheses are the calculated numbers of fatalities using the appropriate linear health effects conversion factor. The actual value must be a whole number.

**Table 5.136.** Population Health Impacts from Drinking Water Downstream of Hanford over 10,000 Years – Alternative Group E<sub>3</sub>, Upper Bound Waste Volume

Waste Type	Tri-Cities, Washington		Portland, Oregon	
	Population Dose (person-rem)	Estimated Cancer Fatalities	Population Dose (person-rem)	Estimated Cancer Fatalities
Previously Disposed of	1.3E-02	0 (8E-06) <sup>(a)</sup>	3.3E-02	0 (2E-05)
Disposed of 1996–2007	1.5E-02	0 (9E-06)	4.0E-02	0 (2E-05)
Projected	1.9E-01	0 (1E-04)	5.1E-01	0 (3E-04)
Total	2.2E-01	0 (1E-04)	5.8E-01	0 (3E-04)

(a) The numbers expressed in parentheses are the calculated numbers of fatalities using the appropriate linear health effects conversion factor. The actual value must be a whole number.

**Table 5.137.** Maximum Annual Drinking Water Dose for a Hypothetical Well 1 km Downgradient from the 200 West Area, Alternative Group E<sub>3</sub>

Waste Volume	Radionuclide	Maximum Annual Dose	
		Dose, mrem	Years post-2046
Hanford Only	Carbon-14	0.0	Not Present
	Technetium-99	4.7E-02	1,730
	Iodine-129	1.1E-01	280
	Uranium <sup>(a)</sup>	1.1E-03	10,000
	Total	1.2E-01	280
Upper Bound	Carbon-14	0.0	Not Present
	Technetium-99	3.7E-02	1,720
	Iodine-129	1.1E-01	280
	Uranium <sup>(a)</sup>	1.8E-03	10,000
	Total	1.2E-01	280

(a) The entry for uranium includes the contributions from all uranium isotopes.

**Table 5.138.** Maximum Annual Drinking Water Dose for a Hypothetical Well 1 km Downgradient from the ERDF Site, Alternative Group E<sub>3</sub>

Waste Volume	Radionuclide	Maximum Annual Dose	
		Dose, mrem	Years post-2046
Hanford Only	Carbon-14	7.6E-08	10,000
	Technetium-99	2.6E-01	1,470
	Iodine-129	8.1E-02	1,810
	Uranium <sup>(a)</sup>	0.0	Not Present
	Total	3.4E-01	1,780
Upper Bound	Carbon-14	2.5E-05	10,000
	Technetium-99	2.8E-01	1,470
	Iodine-129	8.2E-02	1,810
	Uranium <sup>(a)</sup>	0.0	Not Present
	Total	3.5E-01	1,770

(a) The entry for uranium includes the contributions from all uranium isotopes.



**Table 5.139.** Maximum Annual Drinking Water Dose for a Hypothetical Well 1 km Downgradient Northwest from the 200 East Area, Alternative Group E<sub>3</sub>

Waste Volume	Radionuclide	Maximum Annual Dose	
		Dose, mrem	Years post-2046
Hanford Only	Carbon-14	2.5E-03	10,000
	Technetium-99	1.4E-02	1,530
	Iodine-129	1.1E-01	120
	Uranium <sup>(a)</sup>	4.8E-02	10,000
	Total	1.4E-01	1,550
Upper Bound	Carbon-14	2.5E-03	10,000
	Technetium-99	1.5E-02	1,510
	Iodine-129	1.1E-01	120
	Uranium <sup>(a)</sup>	5.4E-02	10,000
	Total	1.6E-01	1,520

(a) The entry for uranium includes the contributions from all uranium isotopes.

**Table 5.140.** Maximum Annual Drinking Water Dose for a Hypothetical Well 1 km Downgradient Southeast from the 200 East Area, Alternative Group E<sub>3</sub>

Waste Volume	Radionuclide	Maximum Annual Dose	
		Dose, mrem	Years post-2046
Hanford Only	Carbon-14	0.0	Not Present
	Technetium-99	1.9E-02	10,000
	Iodine-129	3.2E-03	10,000
	Uranium <sup>(a)</sup>	2.1E-02	10,000
	Total	4.4E-02	10,000
Upper Bound	Carbon-14	0.0	Not Present
	Technetium-99	1.9E-02	10,000
	Iodine-129	3.2E-03	10,000
	Uranium <sup>(a)</sup>	2.1E-02	10,000
	Total	4.4E-02	10,000

(a) The entry for uranium includes the contributions from all uranium isotopes.

**Table 5.141.** Maximum Annual Drinking Water Dose for a Hypothetical Well Near the Columbia River, Alternative Group E<sub>3</sub>

Waste Volume	Radionuclide	Maximum Annual Dose	
		Dose, mrem	Years post-2046
Hanford Only	Carbon-14	1.2E-04	10,000
	Technetium-99	3.3E-02	1,790
	Iodine-129	1.3E-02	270
	Uranium <sup>(a)</sup>	4.6E-03	10,000
	Total	4.4E-02	1,800
Upper Bound	Carbon-14	1.2E-04	10,000
	Technetium-99	3.5E-02	1,790
	Iodine-129	1.3E-02	270
	Uranium <sup>(a)</sup>	4.7E-03	10,000
	Total	4.5E-02	1,790

(a) The entry for uranium includes the contributions from all uranium isotopes.

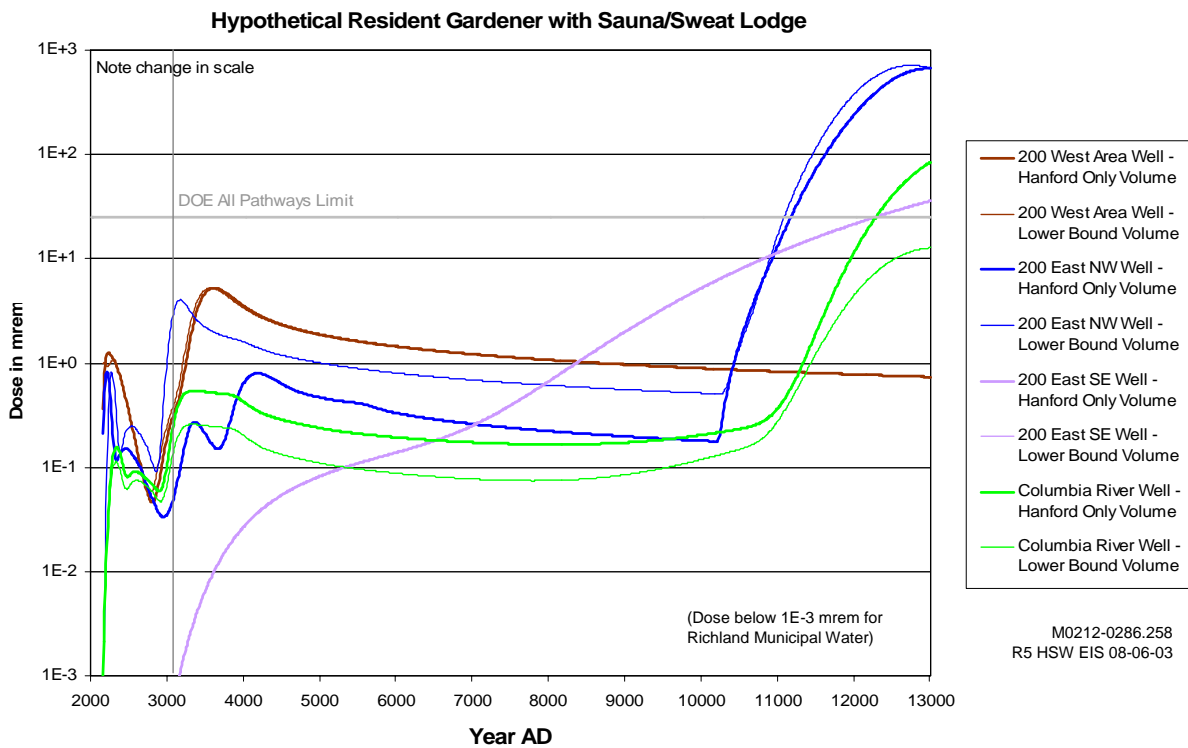
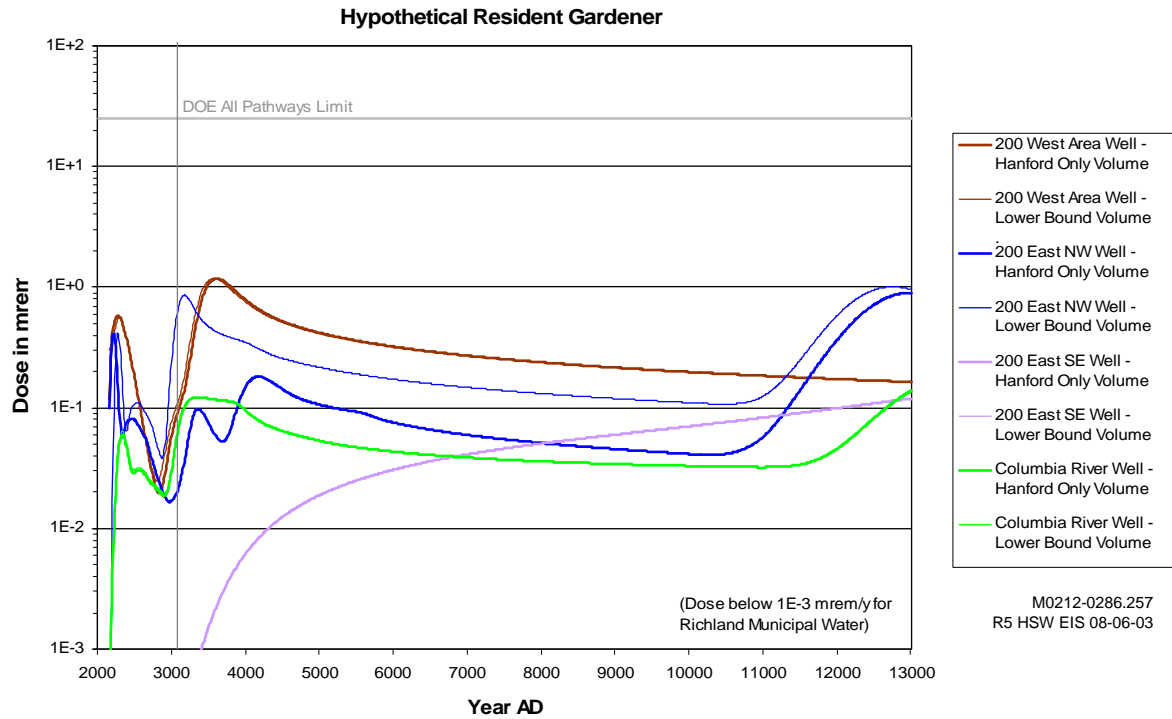
### 5.11.2.1.6 No Action Alternative

The potential consequences to the MEI are presented in Figure 5.43 for a hypothetical individual residing 1 km (0.6 mi) downgradient from disposal facilities, a hypothetical individual residing near the Columbia River, and for users of municipal water from the Richland water supply system. Results are presented for the Hanford Only and Lower Bound waste volumes (there is no Upper Bound waste volume for the No Action Alternative).

The estimated annual doses for the hypothetical resident gardener are well below the DOE dose limit of 25 mrem/yr (DOE 2001a) for these locations within the 10,000-year timeframe. The estimated annual doses also are below the benchmark DOE drinking water dose limit of 4 mrem/yr (DOE 1993) for these locations within the 10,000-year timeframe. The results for the hypothetical resident gardener with the sauna/sweat lodge exposure pathway are below the 25-mrem annual limit within the 1000-year timeframe, but exceed the limit at later times (after about 9,000 years).

Impacts on users of Columbia River water downstream of Hanford were based on the collective population drinking water dose (2 L/day) for the Tri-Cities, Washington, population and a population the size of Portland, Oregon, and located at about that point on the Columbia River. The doses are calculated over the 10,000-year period and are presented in Table 5.142 for the Hanford Only waste volume and in Table 5.143 for the Lower Bound waste volume. All estimated collective radiation doses to downstream populations resulting from drinking Columbia River water are below levels expected to result in any LCFs.

The estimated annual drinking water dose for each of the groundwater points of analysis, represented as wells, are presented for comparison with the DOE benchmark drinking water dose of 4 mrem/yr (DOE 1993). The results are presented in Tables 5.144 through 5.147 for the locations 1 km (0.6 mi) downgradient from the 200 West Area, the 200 East Area (NW), the 200 East Area (SE), and near the Columbia River, respectively.



**Figure 5.43.** Annual Dose to a Maximally Exposed Individual at Various Times over 10,000 Years Using Water from Various Locations – No Action Alternative, Hanford Only and Upper Bound Waste Volumes

**Table 5.142.** Population Health Impacts from Drinking Water Downstream of Hanford over 10,000 Years – No Action Alternative, Hanford Only Waste Volume

Waste Type	Tri-Cities, Washington		Portland, Oregon	
	Population Dose (person-rem)	Estimated Cancer Fatalities	Population Dose (person-rem)	Estimated Cancer Fatalities
Previously Disposed of	6.3E-03	0 (4E-06) <sup>(a)</sup>	1.7E-02	0 (1E-05)
Disposed of 1996–2007	1.5E-01	0 (9E-05)	4.0E-01	0 (2E-04)
Projected (ILAW)	1.4E-02	0 (8E-06)	3.9E-02	0 (2E-05)
Total	1.5E-01	0 (9E-05)	4.1E-01	0 (2E-04)

(a) The numbers expressed in parentheses are the calculated numbers of fatalities using the appropriate linear health effects conversion factor. The actual value must be a whole number.

**Table 5.143.** Population Health Impacts from Drinking Water Downstream of Hanford over 10,000 Years – No Action Alternative, Lower Bound Waste Volume

Waste Type	Tri-Cities, Washington		Portland, Oregon	
	Population Dose (person-rem)	Estimated Cancer Fatalities	Population Dose (person-rem)	Estimated Cancer Fatalities
Previously Disposed of	6.3E-03	0 (4E-06) <sup>(a)</sup>	1.7E-02	0 (1E-05)
Disposed of 1996–2007	1.5E-01	0 (9E-05)	4.0E-01	0 (2E-04)
Projected (ILAW)	1.4E-02	0 (4E-06)	3.9E-02	0 (1E-05)
Total	1.6E-01	0 (9E-05)	4.1E-01	0 (2E-04)

(a) The numbers expressed in parentheses are the calculated numbers of fatalities using the appropriate linear health effects conversion factor. The actual value must be a whole number.

**Table 5.144.** Maximum Annual Drinking Water Dose for a Hypothetical Well 1 km Downgradient from the 200 West Area, No Action Alternative

Waste Volume	Radionuclide	Maximum Annual Dose	
		Dose, mrem	Years post-2046
Hanford Only	Carbon-14	0.0	Not Present
	Technetium-99	3.2E-01	1560
	Iodine-129	1.2E-01	280
	Uranium <sup>(a)</sup>	0.0	Not Present
	Total	3.5E-01	1560
Lower Bound	Carbon-14	0.0	Not Present
	Technetium-99	3.2E-01	1560
	Iodine-129	1.2E-01	280
	Uranium <sup>(a)</sup>	0.0	Not Present
	Total	3.5E-01	1560

(a) The entry for uranium includes the contributions from all uranium isotopes.

**Table 5.145.** Maximum Annual Drinking Water Dose for a Hypothetical Well 1 km Downgradient Northwest from the 200 East Area, No Action Alternative

Waste Volume	Radionuclide	Maximum Annual Dose	
		Dose, mrem	Years post-2046
Hanford Only	Carbon-14	2.5E-03	10,000
	Technetium-99	4.7E-02	2,140
	Iodine-129	1.1E-01	120
	Uranium <sup>(a)</sup>	2.3E-01	10,000
	Total	2.4E-01	10,000
Lower Bound	Carbon-14	2.5E-03	10,000
	Technetium-99	1.9E-02	10,000
	Iodine-129	1.1E-01	120
	Uranium <sup>(a)</sup>	4.5E-01	10,000
	Total	4.8E-01	10,000

(a) The entry for uranium includes the contributions from all uranium isotopes.

**Table 5.146.** Maximum Annual Drinking Water Dose for a Hypothetical Well 1 km Downgradient Southeast from the 200 East Area, No Action Alternative

Waste Volume	Radionuclide	Maximum Annual Dose	
		Dose, mrem	Years post-2046
Hanford Only	Carbon-14	0.0	Not Present
	Technetium-99	1.9E-02	10,000
	Iodine-129	3.2E-03	10,000
	Uranium <sup>(a)</sup>	2.1E-02	10,000
	Total	4.3E-02	10,000
Lower Bound	Carbon-14	0.0	Not Present
	Technetium-99	1.9E-02	10,000
	Iodine-129	3.2E-03	10,000
	Uranium <sup>(a)</sup>	2.1E-02	10,000
	Total	4.3E-02	10,000

(a) The entry for uranium includes the contributions from all uranium isotopes.

**Table 5.147.** Maximum Annual Drinking Water Dose for a Hypothetical Well Near the Columbia River, No Action Alternative

Waste Volume	Radionuclide	Maximum Annual Dose	
		Dose, mrem	Years post-2046
Hanford Only	Carbon-14	7.2E-05	10,000
	Technetium-99	3.2E-02	1,300
	Iodine-129	1.6E-02	280
	Uranium <sup>(a)</sup>	1.3E-02	10,000
	Total	3.7E-02	1,310
Lower Bound	Carbon-14	7.2E-05	10,000
	Technetium-99	3.4E-02	1,370
	Iodine-129	1.6E-02	280
	Uranium <sup>(a)</sup>	1.3E-02	10,000
	Total	3.9E-02	1,370

(a) The entry for uranium includes the contributions from all uranium isotopes.

### 5.11.2.2 Intrusion into Disposal Facilities

Although considered highly unlikely, inadvertent intrusion into disposal facilities by humans or other biota is possible if institutional controls are absent. The impacts of such intrusions, assuming they were to occur, are presented in this section.

#### 5.11.2.2.1 Inadvertent Human Intrusion

Two scenarios were analyzed: 1) impacts on a resident gardener (maximally exposed individual) who drilled a well into waste and mixed the radionuclide-laden drilling mud into soil in which a garden was planted and 2) impacts on a resident gardener who excavated a basement for a dwelling/house and similarly mixed the excavated radionuclide-laden soil into soil in which a garden was planted. Except for metals, grout, and asphalt, it was assumed that waste extracted from the disposal facilities would be indistinguishable from surrounding soil. Details of the exposure scenarios are presented in Volume II, Appendix F.

Both the drilling and excavation scenarios use a maximum inventory in LLW, corresponding to spent B Plant filters from recovery and encapsulation of strontium and cesium from tank waste. That waste stream contains the maximum radionuclide inventory of any LLW previously disposed of, or expected to be disposed of, without the additional containment provided by HICs or by in-trench grouting. The use of that inventory for the intruder scenarios provides a bounding case.

#### 5.11.2.2.2 Drilling Scenario

It is assumed that a well is drilled directly through waste buried under a Modified RCRA Subtitle C Barrier. A 5-m (16-ft) long, 30-cm (12-in) diameter core of waste was removed and mixed instantaneously into the top 15 cm (6 in) of clean soil. A garden was cultivated in the now contaminated soil. Pathways considered in the derivation of the dose conversion factors included ingestion of vegetables

grown in the contaminated soil, ingestion of contaminated soil, inhalation of radionuclides, and external exposure to contaminated soil while working in the garden or residing in the house built on top of the waste site. Details of the dose estimation methods are provided in Volume II, Appendix F.

Dose estimates and probabilities of the resident gardener experiencing an LCF because of intrusions at various points in time after loss of active institutional control (assumed to be 100 years) are presented in Table 5.148. No radiological consequences in the form of LCFs would be anticipated from intrusion, via drilling, into the LLBGs.

### 5.11.2.2.3 Excavation Scenario

It is assumed that during the construction of a nominal 139 m<sup>2</sup> (1500 ft<sup>2</sup>) home that 300 m<sup>3</sup> (11,000 ft<sup>3</sup>) of waste is exhumed, spread over, and mixed with the residential garden soil. A garden is then cultivated in the now contaminated soil. Pathways considered in the derivation of the dose conversion factors included ingestion of vegetables grown in the contaminated soil, ingestion of contaminated soil, inhalation of radionuclides, and external exposure to contaminated soil while working in the garden or residing in the house built on top of the disposal facility. This excavation scenario would only apply to the No Action Alternative. The thickness of the barriers installed in the action alternatives is assumed to preclude excavation into the waste.

The excavation scenario provided the greatest estimated impacts for intruder scenarios. This result was because the excavation intruder exhumed the most waste and contaminated soil that was spread about the garden. Total doses and the associated probability of an LCF from the excavation scenario are listed in Table 5.149. For intrusion by excavation in the year 2146, the intruder's lifetime dose was estimated to be 14,000 rem, and the probability of acute adverse health effects (including possible fatality) from such a dose would be high.

**Table 5.148.** Maximum Impacts to an Individual from Drilling into Low Level Burial Grounds

Consequence	Time Since Year 2046					
	100 Years	200 Years	300 Years	500 Years	1000 Years	10,000 Years
Total Dose (rem)	65	6.2	0.69	0.11	0.097	0.083
Maximum Dose from Single Radionuclide (rem)	34	3.5	0.35	0.038	0.038	0.038
Radionuclide Giving the Maximum Dose	Cesium-137	Cesium-137	Cesium-137	Uranium-238	Uranium-238	Uranium-238
Prob. of LCF <sup>(a)</sup>	4.0E-02	4.0E-03	4.0E-04	7.0E-05	6.0E-05	5.0E-05

(a) The probability of a latent cancer fatality is calculated using  $p(\text{LCF}) = (0.0006)(\text{dose in rem})$ .

**Table 5.149.** Maximum Impacts to an Individual from Excavation into Low Level Burial Grounds

Consequence	Time Since Year 2046					
	100 Years	200 Years	300 Years	500 Years	1000 Years	10,000 Years
Total Dose (rem)	14,000	1400	150	23	21	18
Maximum Dose from Single Radionuclide (rem)	7,400	740	75	8.1	8.1	8.1
Radionuclide Giving the Maximum Dose	Cesium-137	Cesium-137	Cesium-137	Uranium-238	Uranium-238	Uranium-238
Prob. of LCF <sup>(a)</sup>	<sup>(b)</sup>	0.8	0.09	0.01	0.01	0.01
(a) The probability of a latent cancer fatality is calculated using $p(\text{LCF}) = (0.0006)(\text{dose in rem})$ .						
(b) This health effects coefficient for estimating the probability of LCF is not applicable at high doses and dose rates.						

#### 5.11.2.2.4 Biotic Intrusion

Intrusions into uncapped or vegetation-controlled disposal facilities by deep-rooted plants and burrowing animals are known vectors for contamination migration to the surface environment and thus might pose a potential for radiological exposure for onsite workers (Johnson et al. 1994). In addition, intrusion into LLBGs by small burrowing animals has been documented by Hakonson (1986) and Perkins et al. (2001). Known biotic vectors on the disposal facilities have included, in order of frequency, Russian thistle, also known as tumbleweed (*Salsola kali*), western subterranean termite (*Reticulitermes hesperus*), harvester ant (*Pogonomyrmex owyhee*), northern pocket gopher (*Thomomys talpoides*), Townsend's ground squirrel (*Spermophilus townsendii*), and badger (*Taxidea taxus*). A biological control program designed to specifically deal with biotic vectors has been in place on the Hanford Site since 1998, and incidents of biotic-related contamination spread have decreased from a high of 130 incidents in 1999 to 41 in 2001 (Markes and McKinney 2001).

During and after the operational period, the deep-rooted plant of concern is the Russian thistle (DOE-RL 1998), a nuisance weed that has a rooting depth of up to 4.6 m (15 ft). Russian thistle grows in any type of well-drained, un-compacted soil with sunny exposure. Russian thistle could colonize uncapped disposal facilities if they were left fallow for one or more growing seasons. In particular, soil-to-plant concentration ratios for strontium-90 uptake in tumbleweeds can exceed 10 because of a naturally occurring oxalate chelator exuded by the plant roots. To avoid spread of contamination in the disposal facilities during the operational period, waste would be covered with clean soil and the soil surface would be kept free of weeds and burrowing animals through the use of herbicides and other control measures as needed. Biotic intrusion into HICs and in-trench grouted wastes would not be expected to occur.

In all alternative groups except the No Action Alternative, a Modified RCRA Subtitle C Barrier would be placed over the HSW disposal facilities. Although Russian thistle roots might occur in the upper layers of the barrier, a 25-cm (10-in) layer of asphalt just above the trench backfill (at grade) would discourage both deep-rooted plants and burrowing animals.



In the No Action Alternative, only the MLLW trenches would be covered with the Modified RCRA Subtitle C Barrier and, as a consequence, avoidance of surface contamination by tumbleweeds would likely rely on use of herbicides or cultivation of certain species like wheatgrass that would choke out the tumbleweeds and provide for evapotranspiration and reduction in infiltration of water into the waste sites.

## 5.12 Aesthetic and Scenic Resources

Potential impacts on aesthetics and scenic resources arising from implementing Alternative Groups A through E and the No Action Alternative are discussed in this section. The potential impacts would arise mainly from visual intrusions on the natural landscape from expansion of existing buildings; construction of new facilities undertaken in support of the waste transport, treatment, storage, and disposal in the 200 Areas; and activities associated with the borrow pit at Area C. Existing aesthetic and scenic resources of the Hanford Site are described more fully in Section 4.8.10.

Most facilities are not visible to the public because of the size of the facilities, the size of the Hanford Site, the location of the facilities within the Hanford Site, the terrain and restricted access to the site, and the distance between the viewer and the activity on the site.<sup>(a)</sup> The exception is the construction, operation, and eventual closures of the Area C borrow pits (see Figure 4.1 in Section 4).

The Area C borrow pit site is a large polygonal area located adjacent to and south of SR 240 and centered approximately at the intersection of Beloit Avenue and SR 240. This site is about 926 ha (2287 ac) in size and is located next to the Fitzner Eberhardt Arid Lands Ecology Reserve (ALE) but is not part of the Hanford Reach National Monument. The area was designated as conservation (mining) in the Record of Decision (ROD) (64 FR 61615) for the *Final Hanford Comprehensive Land-Use Plan EIS* (DOE 1999). The operation of the borrow pit would not be visible from vehicles using SR 240 from the southwest until they are approximately three-quarters of the way past the site. The reason for this restriction in the viewshed<sup>(b)</sup> is the elevated terrain adjacent to SR 240, separating Area C from the road. Travelers coming from the northwest on SR 240 would notice the site sooner and would be able to observe the activities in passing. The pits, themselves, would be located a minimum of 152 m (500 ft) from SR 240. During borrow pit site development, the bringing of utilities from the Hanford 200 West Area to the site would be noticeable by those traveling on SR 240. The Area C borrow pits would be within the northerly viewshed from Rattlesnake Mountain.

During the operation of the Area C borrow pits, a maximum of approximately 70 pits would be excavated, and 86 ha (213 ac) would be disturbed (Alternative Group B – Upper Bound waste volume). From the air and SR 240, the surface terrain will look pockmarked. During the 12 plus years of the site's operational life, stockpiles of sand, gravel, rock, and silt/loam would be located within 305 m (1000 ft) of SR 240. The individual borrow pits would be restored when their useful life ends. This restoration includes replacing excavated topsoil and re-seeding the area. After extraction of resources from the borrow pit area is complete, the site pit slopes would be re-graded and irregular terrain lines installed to blend the site with the surrounding terrain. No permanent adverse aesthetic or scenic impacts would be expected.

---

(a) Those accelerated process lines (APLs) located within CWC would not be seen and those outside would be dwarfed by the surrounding buildings. As a consequence it is concluded that the APLs would have no impact on aesthetic and scenic resources.

(b) Defined as the scenic resources that can be seen from a particular vantage point.

Fugitive dust associated with development and operation of the Area C borrow pits is a recognized, potential problem, and, as a result, a program would be undertaken to keep fugitive dust controlled during site development and operation, even during off hours. The use of soil adhesives, the application of water, and the discontinuance of excavation and truck loading activities, when winds are excessive, are some of the control measures that would be employed. As a consequence, fugitive dust from the borrow pit area would not be expected to develop into an adverse aesthetic or scenic impact.

Elk occupying the ALE site are sometimes seen from SR 240. Operation of the borrow pit might reduce the likelihood of sighting these animals near Area C because they might migrate farther away from where they might be seen from the highway as a result of these activities.

Travelers can see some site facilities in the 200 West Area on an 11-km (7-mi) segment of SR 240 south of the Yakima Barricade (near the junction of SR 240 and SR 24). At the closest approach, facilities associated with waste-management activities are about 3 km (2 mi) distant. Facilities throughout the 200 Areas are visible from elevated locations, such as Gable Mountain, Gable Butte, and Rattlesnake Mountain, and in the distance from atop the bluffs, east of the Columbia River. These locations generally are not points for public viewing because of their restricted access; however, they may be points of viewshed observation important to Native Americans.

### **5.12.1 Alternative Group A**

The potential aesthetic impacts in Alternative Group A would be those associated with

- use of the modified T Plant Complex
- construction of additional disposal trenches of a deeper and wider design
- construction of caps for disposal facilities would raise the surface about 1.7 m (5.5 ft) for 169 ha to 179 ha (416 to 439 ac) for the Hanford Only to the Upper Bound waste volumes, respectively
- excavation of capping materials, temporarily disturbing 69 to 73 ha (170.4 to 180.6 ac) in the Area C borrow pit.

The T Plant Complex is a facility that has been in place for about 50 years and is not considered in terms of aesthetic impacts. Trench construction and the capped trenches for LLW, MLLW, and ILAW likely would not be noticeable from points of public viewing.

### **5.12.2 Alternative Group B**

The potential aesthetic impacts in Alternative Group B would be those associated with

- construction of a new waste processing facility
- construction of additional disposal trenches of the current design

- capping of the LLW, MLLW, and ILAW trenches over an area ranging between 187 to 210 ha (462 to 519 ac) for the Hanford Only to the Upper Bound waste volumes, respectively
- excavation of capping materials, temporarily disturbing 77 to 86 ha (190 to 210 ac) in the Area C borrow pit area.

The T Plant Complex is a facility that has been in place for about 50 years and, as in Alternative Group A, is not considered in terms of aesthetic impacts. The new waste processing facility probably would be noticeable from SR 240 as one more multi-story building with a 30-m (100-ft) stack. Even if seen, it is questionable that it would be distinguishable from the other industrial buildings in the 200 West Area. Trench construction and the capped trenches for LLW, MLLW, and ILAW likely would not be noticeable from points of public viewing. The potential for aesthetic or scenic impacts related to excavation operations at the borrow pit would be essentially the same as those for Alternative Group A.

### **5.12.3 Alternative Group C**

The potential aesthetic impacts in Alternative Group C would be those associated with

- use of the modified T Plant Complex
- capping of the disposal facilities over an area of 151 to 160 ha (373 to 395 ac) for the Hanford Only to the Upper Bound waste volumes, respectively
- excavation of capping materials, temporarily disturbing 62 to 66 ha (153 to 163 ac).

The T Plant Complex is a facility that has been in place for about 50 years and, as in Alternative Group A, is not considered in terms of aesthetic impacts. Trench construction and the capped LLBGs and LLW, MLLW and ILAW trenches would likely not be noticeable from points of public viewing. The potential for aesthetic or scenic impacts related to excavation operations at the borrow pit would be essentially the same as those for Alternative Groups A and B.

### **5.12.4 Alternative Group D**

Alternative Group D contains three subalternative groupings that are dependent on the location of disposal. The potential for aesthetic impacts for all subalternatives is bounded in the numbers presented below. The potential aesthetic impacts in Alternative Group D would be those associated with

- use of the modified T Plant Complex
- capping of the disposal facilities for 150 to 155 ha (370 to 383 ac) for the Hanford Only to the Upper Bound waste volumes, respectively
- excavation of capping materials, temporarily disturbing 2 to 64 ha (153 to 158 ac).

The T Plant Complex has been in place for about 50 years and, as in Alternative Group A, is not considered in terms of aesthetic impacts. Trench construction and the capped trenches for LLW, MLLW, and ILAW likely would not be noticeable from points of public viewing. The potential for aesthetic or scenic impacts related to excavation operations at the borrow pit would be essentially the same as those for Alternative Groups A through C.

### **5.12.5 Alternative Group E**

Alternative Group E contains three subalternative groupings that depend on the location of disposal. The potential for aesthetic impacts for all subalternatives are bounded in the numbers presented below. The potential aesthetic impacts in Alternative Group E would be those associated with

- use of the modified T Plant Complex
- construction of caps for disposal facilities for an area of 150 to 155 ha (371 to 383 ac) for the Hanford Only and Upper Bound waste volumes, respectively
- excavation of capping materials, temporarily disturbing 62 to 64 ha (153 to 158 ac).

The T Plant Complex is a facility that has been in place for about 50 years and, as in Alternative Groups A, C, and D, is not considered in terms of aesthetic impacts. Trench construction and the capped trenches for LLW, MLLW, and ILAW likely would not be noticeable from points of public viewing. The potential for aesthetic or scenic impacts related to excavation operations at the borrow pit would be essentially the same as those for Alternative Group A.

### **5.12.6 No Action Alternative**

The potential aesthetic impacts in the No Action Alternative would be those associated with

- use of the T Plant Complex
- expansion of the CWC
- construction of caps for disposal facilities for an area of 158 to 159 ha (389 to 393 ac) for the Hanford Only and Upper Bound waste volumes, respectively
- extraction of capping materials from the Area C borrow pit temporarily disturbing 14 ac (35 ac) for that purpose.

Trench construction and the capped MLLW trenches likely would not be noticeable from points of public viewing. ILAW would be disposed of in vaults. Although the expansion of the CWC buildings might be noticeable from SR 240, they are co-located with other buildings in the developed 200 West Area and likely would not be considered an adverse aesthetic impact. Trench construction and capped MLLW trenches likely would not be noticeable from points of public view, particularly SR 240.

The potential for aesthetic and scenic impacts related to excavation operations at the borrow pit would be substantially smaller than those for the action alternative groups, as less than 20 percent of the volume of materials would be needed for MLLW trench capping.

## 5.13 Environmental Justice

Executive Order 12898, *Federal Actions to Address Environmental Justice in Minority Populations and Low-Income Populations* (59 FR 7629), directs Federal agencies in the Executive Branch to consider environmental justice so that their programs will not have "...disproportionately high and adverse human health or environmental effects..." on minority and low-income populations. Executive Order 12898 further directed Federal agencies to consider effects to "populations with differential patterns of subsistence consumption of fish and wildlife." The Executive Branch agencies also were directed to develop plans for carrying out the order. The CEQ provided additional guidance later for integrating environmental justice into the National Environmental Policy Act process in a December 1997 document, *Environmental Justice Guidance Under the National Environmental Policy Act* (CEQ 1997b).

Environmental justice is concerned with assessing the disproportionate distribution of adverse impacts of an action among minority and low-income populations, in which the impacts are significantly greater than those experienced by the rest of the population. Adverse impacts are defined as negative changes to the existing conditions in the natural environment (for example, land, air, water, wildlife, vegetation) or in the human environment (for example, employment, health, land use). The distribution of minority and low-income groups in the Hanford environs is shown graphically in Section 4.8.

Based on the 2000 Census, the 80-km (50-mi) radius area surrounding the Hanford Site has a total population of 482,300 and a minority population of 178,500 (Census 2000). The ethnic composition of the minority population is primarily White Hispanic (24 percent), self-designated "other and multiple" races (63 percent), Native American (6 percent), and two or more races (9 percent). Asians and Pacific Islanders (4 percent) and African American (3 percent) make up the rest. The Hispanic population resides predominantly in Franklin, Yakima, Grant, and Adams counties. Native Americans within the 80-km (50-mi) area reside primarily on the Yakama Reservation and upstream of the Hanford Site near the town of Beverly, Washington.

The 2000 low-income population was approximately 80,700, or 17 percent of the total population residing in the 80-km (50-mi) radius of the Hanford Site. The majority of these households were located to the southwest and northwest of the site (Yakima and Grant counties) and in the cities of Pasco and Kennewick.

Native Americans of various tribal affiliations who live in the greater Columbia Basin rely in part on natural resources for subsistence. According to Harris and Harper (1997), the Nez Perce Tribe, the Confederated Tribes of the Umatilla Indian Reservation, and the Yakama Nation depend on natural resources for dietary subsistence. For example, the treaty of 1855 with the Yakama Nation (Treaty with the Yakama 1855) secured to the Yakamas "...the right of taking fish at all usual and accustomed places, in common with the citizens of the Territory [now the state of Washington] and of erecting temporary buildings for curing them; together with the privilege of hunting, gathering roots and berries, and pasturing their horses and cattle upon open and unclaimed lands." The Wanapum historically lived along the Columbia River and continue to live upstream of the Hanford Site. They fish on the Columbia River and

gather food resources near the Hanford Site. The Confederated Tribes of the Colville Reservation traditionally fished and gathered food resources in the Hanford area. They also are recognized as having cultural and religious ties to the Hanford Site.

The pathways through which the potential environmental impacts are associated, with respect to each of the alternative groups, and how they might disproportionately impact minority or low-income groups were reviewed for each of the associated sections of Section 5. The only aspect that exhibited the potential for disproportionate impacts dealt with implications of cultural resources on the Hanford Site with respect to Native Americans. Furthermore, these would be common to all of the alternative groups. Native American affiliations near the Hanford Site include such places as Gable Mountain, Rattlesnake Mountain, and Gable Butte with respect to their creation beliefs and cultural heritage. Thus disproportionate adverse impacts from implementing any of the alternative groups on minority or low-income populations would be limited to those that might be associated with restricted use of Native American traditional cultural places on the Hanford Site. Additional information on cultural resources were presented in Section 5.7. Other impacts related to aesthetic and scenic resources were addressed in Section 5.12.



## 5.14 Cumulative Impacts

This section presents a discussion of cumulative impacts on the human environment from past, current, and reasonably foreseeable future actions in the Hanford area in conjunction with the actions proposed in the HSW EIS. DOE endeavored to take into consideration all Hanford Site and nearby actions that might make an important contribution to cumulative impacts.

### **The Council on Environmental Quality Assessment of Cumulative Impacts**

In 40 CFR 1508.7, the Council on Environmental Quality (CEQ) defines cumulative impact as:

*"...the impact on the environment from the incremental impact of the action when added to other past, present, and reasonably future actions regardless of what agency (federal or non-federal) or person undertakes such actions. Cumulative impacts can result from individually minor but collectively significant actions taking place over a period of time)."*

In CEQ 1997a, the CEQ states:

*"The continuing challenge of cumulative effects analysis is to focus on important cumulative issues...."*

Past onsite actions that might lead to present-day or future cumulative impacts considered in this assessment include:

- operation of fuel fabrication facilities, reactors, and product separation facilities
- operation of research and development facilities
- management of liquid waste, including tank storage
- disposal of liquid radioactive waste in cribs, ponds, and ditches
- leaks and spills of liquid waste on the ground
- management of spent nuclear fuel
- storage of strontium, cesium capsules, and other radioactive materials
- retrievable storage of TRU waste
- disposal of solid radioactive wastes in trenches and caissons
- stabilization of the Plutonium Finishing Plant
- operation of the ETF, the LERF, the State-approved land disposal system, and the TEDF
- conduct of RCRA/CERCLA remediation projects including operation of the ERDF
- disposal of Navy reactor compartments
- operation of a commercial LLW disposal site by US Ecology, Inc.
- operation of the Columbia Generating Station by Energy Northwest.

Past offsite actions that were considered consists of those of a nearby commercial nuclear fuel fabrication plant and commercial waste treatment facilities.

Current onsite actions that were considered include:

- continued operation of research and development facilities
- preparations for treatment and disposal of tank waste
- continuation of RCRA/CERCLA remediation projects and operation of ERDF
- continued management of TRU waste (including retrieval), LLW, and MLLW
- continued management of spent nuclear fuel
- continued storage of strontium, cesium capsules, and other radioactive materials
- continued stabilization of the Plutonium Finishing Plant
- continued operation of the ETF, the LERF, the State-approved land disposal system, and the TEDF
- disposal of Navy reactor compartments
- operation of the commercial LLW disposal site by US Ecology, Inc.
- operation of the Columbia Generating Station by Energy Northwest.

Current offsite activities that were considered consist of those of the nearby commercial nuclear fuel fabrication plant and commercial waste treatment facilities.

In addition to the activities proposed in the HSW EIS, reasonably foreseeable future onsite activities that were considered include:

- continued operation of research and development facilities
- disposal of tank waste and closure of tank waste sites
- continued management of spent nuclear fuel
- continued storage of strontium, cesium capsules, and other radioactive materials
- continuation of RCRA/CERCLA remediation projects and operation of ERDF
- continued stabilization of the Plutonium Finishing Plant
- continued operation of the ETF, the LERF, the State-approved land disposal system, and the TEDF
- decommissioning and disposition of Hanford's surplus reactors and chemical processing facilities
- continued disposal of Navy reactor compartments
- continued operation of the commercial LLW disposal site by US Ecology, Inc.
- continued operation of the Columbia Generating Station by Energy Northwest.

Reasonably foreseeable future offsite activities that were considered consist of those of the nearby commercial nuclear fuel fabrication plant and commercial waste treatment facilities.

As evidenced by the data presented elsewhere in Section 5 and in the Hanford annual environmental reports, for most resource and potential impact areas, the cumulative impacts from implementation of the HSW EIS alternative groups for the Hanford Only, Lower Bound, and Upper Bound waste volumes, or for the No Action Alternative for the Hanford Only and Lower Bound waste volumes, when added to impacts of the other cited actions, would be small to negligible.

### 5.14.1 Land Use

Consistent with past NEPA actions, land within the 200 Areas has already been committed for Industrial-Exclusive use, including waste disposal (DOE 1999). Radionuclides are present in the soil from past discharges, disposal actions, or tank leaks. Because of their chemical characteristics and very long half-lives (for example, cesium-135 with a half-life of 2.3 million years), some radionuclides are held in the soil indefinitely.

Waste previously disposed of in the solid waste disposal facilities currently occupies 130.5 ha (322 ac) of the Hanford Site. As discussed in Section 5.1, additions to the commitment of land area for waste disposal would range from about 19.2 ha (47 ac) for the Hanford Only waste volume as disposed of in any of the configurations of Alternative Groups D or E to 79.6 ha (197 ac) for the Upper Bound waste volume estimate as disposed of in Alternative Group B (see Section 5.1). Waste management activities through 2046 (Upper Bound waste volume) would be expected to require up to a total of 427 ha (1050 ac) for waste storage, treatment, and disposal facilities and for capping materials. Of this total, 210 ha (519 ac) would be permanently committed for disposal of wastes in Alternative Group B (largest requirements). This amount would represent about 4.2 percent of the 5000 ha (12,350 ac) within the area previously designated for long-term waste management activities in the *Final Hanford Comprehensive Land-Use Plan Environmental Impact Statement* (HCP EIS) (DOE 1999).

### 5.14.2 Air Quality

As discussed in Section 5.2, air quality standards at the Hanford Site boundary would not be approached or exceeded as a result of implementing any of the actions described here or in combination with other reasonably foreseeable actions at the Hanford Site (see Section 5.2). This is due in large part to the current and projected:

- low density and intensity of pollutant emitting activities on the Hanford Site and in neighboring areas of south-central Washington
- relatively low population density in the region (minimizing the contribution of urban impacts on the region's air quality)
- substantial distances between the project activities and the Hanford Site boundary
- atmospheric dispersion conditions at Hanford that are generally favorable and meteorological conditions that could lead to a severe atmospheric stagnation event are of low-to-moderate frequency (and typically of short duration).

Quantification of cumulative non-radiological impacts for criteria pollutants was based on data presented in the Tank Waste Remediation System EIS and is shown in Table 5.150 (DOE and Ecology 1996). The maximum impacts from Hanford Solid Waste Program activities are presented in Table 5.151 for comparison.

**Table 5.150.** Cumulative Air Quality Impacts for Criteria Pollutants

Sources	Maximum Average Concentration ( $\mu\text{g}/\text{m}^3$ )			
	Particulate ( $\text{PM}_{10}$ )	Nitrogen Oxide ( $\text{NO}_2$ )	Sulfur Oxide ( $\text{SO}_2$ )	Carbon Monoxide (CO)
Hanford Site baseline	3	3	19	3
Hanford remedial action	43	40	5	26
Environmental Restoration Disposal Facility	33	Negligible	Negligible	Negligible
Tank Waste Remediation System alternative	98	2.2	27	2500
Standard <sup>(a)</sup>	150 (24 hour)	100 (Annual)	365 (24 hour)	10,000 (8 hour)
(a) 40 CFR 50.				

**Table 5.151.** Largest Criteria-Pollutant Impacts for HSW Operations Among the Alternative Groups and the No Action Alternative

Alternative Group	Hanford Only and Lower Bound Waste Volumes				Upper Bound Waste Volume			
	24-hr $\text{PM}_{10}$	1-hr $\text{SO}_2$	8-hr CO	Annual $\text{NO}_2$	24-hr $\text{PM}_{10}$	1-hr $\text{SO}_2$	8-hr CO	Annual $\text{NO}_2$
Alternative Group A, $\mu\text{g}/\text{m}^3$	69	81	470	0.72	74	98	590	0.80
Alternative Group B, $\mu\text{g}/\text{m}^3$	71	130	800	1.0	90	180	1110	1.1
Alternative Group C, $\mu\text{g}/\text{m}^3$	60	79	460	0.77	61	80	470	0.77
Alternative Group D, $\mu\text{g}/\text{m}^3$	61	84	500	0.79	62	84	500	0.85
Alternative Group E, $\mu\text{g}/\text{m}^3$	60	93	530	0.89	62	95	530	0.89
No Action Alternative, $\mu\text{g}/\text{m}^3$	57	86	460	0.85	Not applicable			
(a) Standards are: 24-hour $\text{PM}_{10}$ = 150 $\mu\text{g}/\text{m}^3$ , 1-hour $\text{SO}_2$ = 1,000 $\mu\text{g}/\text{m}^3$ , 8-hour CO = 10,000 $\mu\text{g}/\text{m}^3$ . Annual $\text{NO}_2$ = 100 $\mu\text{g}/\text{m}^3$								

It should be noted that the values presented in Tables 5.150 and 5.151 are maximums that would occur at different times and locations and may not be additive.

### 5.14.3 Ecological, Cultural, Aesthetic, and Scenic Resources

Cumulative impacts as they pertain to ecological, cultural, aesthetic, and scenic resources in general on the Hanford Site can be found in the HCP EIS, which is incorporated by reference (DOE 1999). There, it was concluded that the potential for cumulative impacts to biological resources could best be

evaluated by determining the amount of *Hanford Site Biological Resources Management Plan* (BRMaP) Level III and Level IV resources that could be affected.

The HSW EIS does not consider any change in land use designated by the HCP EIS Record of Decision (64 FR 61615). The HCP EIS took a long-term look at the resources that would be required for the major reasonably foreseeable projects. Capping on the Central Plateau and complete conversion of the Industrial-Exclusive to industrial areas were two of the impacts assumed at that time. The HCP EIS contains the distribution of BRMaP Levels II, III, and IV resources for the DOE preferred alternative—prior to the 24 Command Fire. BRMaP mitigation would have been required for those areas that were designated Level III or Level IV. Assuming that the pre-fire condition represents the edaphic potential of the burned areas, the HCP EIS identified 44,183 ha (109,179 ac) in Conservation (Mining) and 5,064 ha (12,323 ac) in Industrial-Exclusive as BRMaP Level III resources, out of a site resource base of 148,080 ha (365,914 ac). These areas contain no BRMaP Level IV resources. In the HCP EIS, Conservation (Mining) was chosen for 30 percent of the site, while Preservation was chosen for 53 percent of the site.

Field surveys conducted during 2002 for each of the areas in which any of the HSW EIS alternative groups might be implemented identified the near PUREX disposal facility site (up to 24.5 ha [60 ac]) as mature shrub-steppe habitat that could qualify under BRMaP Level III and require mitigation. Isolated element occurrences in Area C might also qualify as Level III or Level IV but would need to be re-examined nearer the time of the planned disturbance (see Section 5.5).

The activities described in this EIS would take place in areas that are, and will be for the foreseeable future, dedicated to industrial type uses. However, the presence of the Hanford Reach Monument with its relatively low-density use and the portions of the Hanford Site designated for preservation/conservation would result in large areas remaining in a natural state.

Surveys of areas to be used in implementing each of the alternative groups did not disclose the presence of cultural resources (see Section 5.7). However, changes to the viewshed of the Hanford 200 Areas would occur as a result of activities evaluated in this EIS as well as other programs at Hanford. As facilities are closed and barriers are placed on waste disposal facilities, the visual appearance of waste disposal facilities would likely become more similar to the to pre-Hanford Site condition. Future uses of the Central Plateau are likely to include structures and activities consistent with its designation for Industrial-Exclusive use in the HCP EIS (DOE 1999). However, most areas of the viewshed on the Hanford Site are expected to remain in a near natural state due to designation of approximately 80,000 ha (200,000 ac) of the site as a national monument (65 FR 37253) and of many other major areas of the site for preservation/conservation (DOE 1999).

#### **5.14.4 Geologic Resources**

Geologic resources consisting of sand, gravel, silt/loam, and perhaps basalt would be required in the construction of Modified RCRA Subtitle C Barriers for any of the alternative groups and for the Hanford barrier to cover immobilized low-activity waste (ILAW) as disposed of in the No Action Alternative. The expected quantities of these resources were presented in Section 5.10. The resources would be obtained

from Area C identified in the HCP EIS (DOE 1999) as Conservation (Mining). In areal extent, the requirements would at most (Alternative Group B) amount to about 10 percent of Area C designated for borrow-pit materials.

This HSW EIS does not consider any change in land use designated by the HCP EIS ROD (64 FR 61615). The HCP EIS took a long-term look at the resources that would be required for the major reasonably foreseeable projects. Capping on the Central Plateau and complete conversion of the Industrial-Exclusive to industrial areas were two of the impacts assumed at that time. Appendix D of the HCP EIS discussed using 36.1 million cubic meters (47.3 million cubic yards) of fine textured soils and developing a basalt source that could yield 15.3 million cubic meters (20 million cubic yards) of basalt riprap. A maximum of 90 ha (222 ac) of area C would be used for geologic resource development, out of the 44,183 ha (109,179 ac) reserved by the HCP EIS for Conservation (Mining). In the HCP EIS, Conservation (Mining) was chosen for 30 percent of the site, while Preservation was chosen for 53 percent of the site.

### **5.14.5 Socioeconomics**

If a number of the projects being considered for Hanford were undertaken simultaneously, the activity levels and the workers needed to support the activities could temporarily strain community infrastructure. The impact of any of the HSW EIS alternative groups or the No Action Alternative would be small (300 to 400 workers out of 15,000 workers at the Hanford Site, see Section 5.6). The current projected baseline for Hanford shows declining employment beginning in about 2005. If this baseline is maintained and other considerations remain equal, most existing components of community infrastructure would be adequate to accommodate population growth of about 2,000 residents associated with any of the HSW EIS alternative groups in the long run. However, a projected 7,000 new residents are expected move into the area to support construction of the Hanford tank waste treatment plant. These new arrivals and any early arrival of the up to about 2,000 new residents related to the Hanford solid waste program in the Tri-Cities area could challenge the capacities of the local real estate markets, the transportation network, and the primary and secondary education facilities.

In addition, other projects are expected to be underway at Hanford in the near term, such as operations at the Hazardous Materials Management and Emergency Response (HAMMER) facility; cleanup of several older reactors and other buildings; and actions to remediate the K Basins, the vadose zone, and the groundwater on the site. These additional projects could increase Hanford employment by a few hundred workers during the period 2003 to 2010 and, therefore, might also affect the socioeconomic context against which the effects of any LLW, MLLW, and TRU waste-related activity under the proposed action would need to be judged (see Section 5.6).

While the increases in workers (300 to 400) mentioned above would be in addition to the existing Hanford workforce of about 15,000, that work force is anticipated to temporarily increase (from activities other than those associated with Hanford solid waste), then generally decline after about 2005, and finally continue to decline throughout the period of analysis (see Section 5.6, Figure 5.22). Overall employment may even decline at a faster rate than presently forecasted depending on the success of accelerated site

cleanup. However, the impact of implementing any of the Hanford solid waste alternative groups would be a small addition to cumulative socioeconomic impacts.

### **5.14.6 Public Health**

Although large amounts of various chemicals have been used during Hanford operations over the years, the breadth and depth of documented, quantitative information regarding these chemicals is very limited when compared with the amount of information available about radioactive materials. However, as shown in Section 5.11, hazards from releases of chemicals to the atmosphere have been calculated to be very small for all the alternative groups and would not be expected to add measurably to cumulative impacts regardless of their magnitude.

As was shown in Section, 4.5.3.2, Figure 4.19, a number of chemicals, principally from past liquid discharges to the ground, are found in the groundwater at Hanford. Again, there is only fragmentary data on the source quantities and transport to groundwater of these chemicals. In one case, however, it was estimated that the inventory of nitrate in groundwater beneath the 200 Areas exceeded 90,000 tonnes (100,000 tons) (ERDA 1975). The inventory of nitrate in Hanford solid waste is on the order of 6.2 tonnes (6.8 tons), which is small relative to other sources of this chemical at Hanford. In addition to the minimal impacts reported for chemicals in Section 5.3, this suggests that the impacts of other chemicals in Hanford solid waste would not contribute substantially to the cumulative impacts of existing chemicals in groundwater.

Cumulative impacts for the atmospheric, surface water, and groundwater pathways, which could lead to potential radiological impacts on the public, are presented in the following subsections (also see Section 5.11).

#### **5.14.6.1 Atmospheric Pathway**

A summary of cumulative radiological impacts on public health due to radiological air emissions from past, current, and reasonably foreseeable future activities at Hanford is provided in Table 5.152. Examples of past activities include operation of the fuel fabrication plants, reactors, the PUREX Plant and other fuel processing facilities; the Plutonium Finishing Plant; and research facilities. Current activities include site cleanup, waste disposal, and tank waste stabilization; reasonably foreseeable future activities include continuation of site cleanup, waste disposal, immobilization of both high-level and low-activity waste, and related activities.

The cumulative population dose since the startup of Hanford operations was estimated to be 100,000 person-rem (DOE 1995). The number of inferred latent cancer fatalities (LCFs) since Hanford startup from such a population dose would amount to about 60, essentially all of which would be attributed to a dose received in the 1945 to 1952 time period.

For perspective, since startup of the Hanford Site, the population of interest (assuming an average population within 80 km [50 mi] of 380,000 and an individual dose of 0.3 rem/yr [NCRP 1987]) would have received about 6 million person-rem from naturally occurring radiation sources (that is, natural background), from which about 4000 LCFs could be inferred.

**Table 5.152.** Cumulative Population Health Effects in the Hanford Environs from Atmospheric Pathways due to Hanford Site Activities<sup>(a)</sup>

Source of Impacts	Dose Person-rem	Latent Cancer Fatalities <sup>(b)</sup>
Past Hanford operations (DOE 1995)	100,000	60
<b>Ongoing and Proposed Operations</b>		
Hanford operations (1997–2046) (Poston et al. 2001) <sup>(c)</sup>	15	0
Columbia generating station (30 yr) (DOE 1996b)	21	0
HSW EIS—atmospheric releases		
Alternative Groups A, C, D, & E—range <sup>(d)</sup>	0.15–0.24	0
Alternative Group B—range <sup>(d)</sup>	0.19–0.29	0
No Action Alternative—range <sup>(e)</sup>	0.10–0.12	0
<b>Reasonably Foreseeable Operations</b>		
Plutonium Finishing Plant stabilization (DOE 1996b)	140 <sup>(f)</sup>	0
K Basin fuel treatment and storage (DOE 1996a)	120 <sup>(f)</sup>	0
TWRS phased implementation alternative (DOE and Ecology 1996)	400 <sup>(f)</sup>	0
Cumulative total	100,696.3 <sup>(g)</sup>	60
<b>Perspective</b>		
Cumulative natural background dose—100 yr, 1946–2046	12,000,000	7,000

- (a) Assumes constant population of about 380,000.
- (b) Assumes six inferred LCFs per 10,000 person-rem. Values less than 0.5 were rounded to zero.
- (c) Assumed to continue at the 2000 population dose rate.
- (d) Range based on Hanford Only and Upper Bound waste volumes.
- (e) Range based on Hanford Only and Lower Bound waste volumes.
- (f) Value based on previous NEPA analyses.
- (g) For the solid waste program, this number includes only the value of 0.3 person-rem from Alternative Groups A, B, C, D, or E, Upper Bound waste volume activities.

If the entire Hanford sitewide contribution to population dose from all exposure pathways were to remain at calendar-year 2000 levels (Poston et al. 2001) through the period ending in 2046, the estimated collective population dose would be about 36 person-rem. No LCFs would be expected from such a population dose.

This estimated level was based on a 0.3-person-rem/yr population dose from DOE facilities at Hanford and a 0.7-person-rem/yr population dose from Energy Northwest’s Columbia Generating Station for 30 years of operation (DOE 1996b). The largest contribution from solid waste management alternative groups to the total population dose of 36 person-rem would be about 0.3 person-rem (see Section 5.11).



Vitrification of the Hanford tank wastes could contribute up to about 400 person-rem to the cumulative, collective population dose (DOE and Ecology 1996). The cumulative, collective population dose from Plutonium Finishing Plant activities could be up to 140 person-rem (DOE 1996b). Similarly, remediation of K Basins could be up to 120 person-rem (DOE 1996a). No other activities are foreseen that would add substantially to these doses, and the total dose from these activities through the period ending in 2046 would not be expected to result in any LCFs.

Again for perspective, the doses to the local population from naturally occurring radioactive sources would result in about an additional 6 million person-rem for the 50-year period ending in 2046, from which about 4000 LCFs also would be inferred. Thus, over about 100 years from the start of the Hanford operations to the year 2046, about 7000 LCFs might have resulted from naturally occurring sources. To this number of LCFs resulting from natural sources would be the inference that Hanford operations might have added about 60 LCFs as a result of airborne releases of radioactive material mainly during the 1945 to 1952 time period.

#### **5.14.6.2 Surface Water Pathway**

Past impacts associated with the water pathway were principally associated with contamination of Columbia River water that was used as once-through coolant for the eight Hanford production reactors. Various elements present in the incoming water were made radioactive during their passage through one or more of these reactors.<sup>(a)</sup> In addition, some of the corrosion products that formed in the plants' piping were made radioactive and entered the water. Fuel element failures (slug ruptures) also exposed the fuel to cooling water and added contaminants to the water. On an average annual basis, the principal radionuclides contributing to a potential dose were phosphorous-32, chromium-51, zinc-65, arsenic-76, and neptunium-239. Contamination also occurred as a result of adding water-conditioning agents, with hexavalent chromium as the principal contaminant.

- 
- (a) A ninth reactor, N Reactor, did not use once-through cooling. Past discharges to nearby trenches is a source for seepage of some contaminants into the river.
  - (b) Before 1971, higher doses would have been experienced by those individuals making recreational use of the Columbia River, consuming food crops grown with irrigation water derived from the river, consuming fish and waterfowl inhabiting the river, and consuming seafood harvested from along the Washington and Oregon coast. Due to the number of pathways and uncertainties in numbers of individuals involved, this aspect has not been quantified on a collective basis for the 1944 to present time period. Estimates of maximum and average representative individual doses may be found in Farris et al. (1994). Doses from 1971 to present were estimated from the maximally exposed individual (MEI) doses taken from annual reports and, consequently, are substantially higher than would be expected for individuals with typical dietary habits (for example, the annual per capita dose for 1999 was reported as 0.0007 mrem, and the MEI dose was reported as 0.008 mrem, thus the MEI dose overestimates the per capita dose by a factor of about 10.)

An estimate of the collective population dose to the nearest downstream users of the Columbia River (Richland, Pasco, and Kennewick, Washington) from 1944 to present would amount to about 3000 person-rem, most of which occurred before 1971 at which time the last reactor that used once-through cooling was shut down. This estimate was based on the dose to people who drank water supplied by municipal water plants and estimates of the populations for Richland (after startup of its water treatment plant in late 1963), Pasco, and Kennewick, and included a nominal amount of time for people who engaged in boating and swimming in the Columbia River.<sup>(b)</sup> From 1971 to present, the collective population dose was estimated to be less than 400 person-rem. From a collective dose of 3000 person-rem, 2 LCFs could be inferred. The collective population drinking water dose for 2001 from the surface water pathway was determined to be 0.0024 person-rem (Poston et al. 2001). If that annual dose were to continue over 10,000 years, the total from all future Hanford activities might amount to 27 person-rem. The addition of radionuclides from the disposal of Hanford solid waste over that period was less than or equal to 0.3 person-rem in the Tri-Cities. Neither the current projection of drinking water dose nor that projected from disposal of Hanford solid waste would add substantially to the past cumulative population dose derived from the Columbia River of 3400 person-rem.

The presence of contaminants in surface water as a result of inflow of groundwater and a discussion of the cumulative impacts of contaminants in the groundwater, itself, are included in the next subsection.

#### **5.14.6.3 Groundwater Pathway**

Cumulative groundwater impacts are examined in the context of existing sources of contamination in the soil, vadose zone, and groundwater. The following contaminants have been consistently detectable in soil on the Hanford Site: strontium-90, cesium-137, uranium-238, plutonium isotopes (238, 239, 240), and americium-241. Contaminants in the vadose zone include cobalt-60, strontium-90, technetium-99, cesium-137, europium isotopes (152, 154), uranium isotopes (234, 235, 238), and plutonium isotopes (239, 240). Contaminants in the vadose zone also include non-radioactive materials including metals, volatile organics, semivolatile organics, and inorganics (Poston et al. 2002). Current contamination of the groundwater and vadose zone is due primarily to past liquid waste disposal practices involving hazardous chemicals and radionuclides. The existing level of contamination in the groundwater would exceed Federal Drinking Water Standards if it were a source of drinking water as defined in the standards (Poston et al. 2002). Hazardous chemical contaminants that would exceed this benchmark include nitrate, carbon tetrachloride, trichloroethene, and chromium, and radiological contaminants that exceed the standards include tritium, iodine-129, strontium-90, technetium-99, and uranium. Concentrations of these radionuclides and hazardous chemicals currently in groundwater are shown in Section 4.5.3.1, Figures 4.18 and 4.19, respectively.

Action alternatives analyzed in this EIS would not cause the dose from drinking groundwater at 1 km from the disposal facilities to exceed the DOE 4-mrem-per-year benchmark public drinking water limit (see Section 5.11.2.1). Analysis of the preferred alternative also indicated the dose from drinking groundwater at the disposal facility boundary would not exceed the DOE limit (see Section 5.11.2.1.4). By the time the waste constituents from the action alternatives are predicted to reach groundwater (hundreds of years) the waste constituents would not superimpose on existing plumes and would not exceed the benchmark dose, because the existing groundwater contaminant plumes will have migrated out of the unconfined aquifer by then.

Radionuclides leached from wastes disposed of in HSW disposal facilities could eventually be transported through the vadose zone to groundwater. For this analysis, it was assumed that an individual drilled a well through the vadose zone to the groundwater and used the groundwater as a source of drinking water. As an indication of cumulative Hanford groundwater impacts, the annual dose to an individual drinking 2 liters of that water per day and taking into account all wastes intentionally or unintentionally disposed of on the Hanford Site since the beginning of operations and waste forecast to be disposed of through 2046<sup>(a)</sup> was calculated for technetium-99, iodine-129, and uranium isotopes using the System Assessment Capability (SAC) (Kincaid et al. 2000) software and data. Technetium-99, iodine-129, and uranium were selected for analysis because they are expected to be the dominant contributors to risk in the future. Carbon-14 was omitted from this cumulative assessment based on prior analyses (Kincaid et al. 1998) that showed it to be less mobile and not substantially influencing cumulative results. The distribution coefficients assigned to carbon-14 in solid waste for that analysis were substantially greater than those assigned to uranium and iodine-129, and, consequently, carbon-14 would not be expected to release from solid waste deposits into groundwater during this 10,000-year assessment.

The more limited data available for chemical inventories in solid waste disposals would not support a SAC analysis on the same scale as the initial assessment conducted for radionuclides. However, based on available information, chemicals in solid waste do not appear to be as important in terms of human health impacts as the key radionuclides—technetium-99, iodine-129, and uranium. Carbon tetrachloride and chromium in Hanford solid waste are not expected to add substantially to impacts of those substances from other Hanford sources, that is, liquid discharge sites and unplanned releases. For further discussion of the potential impacts from hazardous chemical constituents in Hanford solid waste, see Volume I, Sections 5.3.2 and 5.3.5.

---

(a) ILAW from treating tank waste was not included in the original SAC or initial assessment. Initially the SAC was tasked to address a 1000-year period; however, technetium-99 and iodine-129 would not release from the ILAW form to the water table within that time period. An approximation of the drinking water doses combining SAC and ILAW results for technetium-99, iodine-129, and uranium is shown as a function of time in Figures 5.38 through 5.43. Melters and naval reactor compartments also were not included as sources of radioactive releases in the original SAC assessment. They, like ILAW, were assumed to not release any activity during the initial 1000-year post-closure period. Both of these waste types are encased in substantial steel containment and contain substantially lower inventories of technetium-99 and uranium than ILAW; therefore, they would not contribute to groundwater contamination and were not simulated.

A SAC analysis of hypothetical future impacts was conducted based on conservative assumptions (that is, absence of active institutional controls and cessation of barrier maintenance). The SAC analysis of the initial assessment for 10,000 years completed for the HSW EIS was comprised of two simulations: a stochastic analysis<sup>(a)</sup> and a deterministic analysis.<sup>(b)</sup>

### **Liquid Discharge of Carbon Tetrachloride**

Groundwater modeling has been performed in support of the Hanford Carbon Tetrachloride Innovative Treatment Remediation Demonstration (ITRD) Program (Truex et al. 2001). Simulations, as part of this study, of the liquid discharge sites receiving carbon tetrachloride were based on an assumption that approximately 65 percent, 30 percent, 10 percent, and 1 percent of the source could reach the groundwater. Approximately 1 to 2 percent of the original carbon tetrachloride inventory is estimated to now exist in the plume based on averaged groundwater measurements (Ebasco Services, Inc. 1993). Other model parameters varied in Truex et al. (2001) included porosity, soil/water equilibrium partition coefficient ( $K_d$ ), and abiotic degradation rate ( $K_a$ ). The analysis revealed that a breakpoint for cleanup requirements lies between 1 and 10 percent of the initial discharge inventory reaching groundwater. If 1 percent of the inventory reaches groundwater, no cleanup is likely to be required, whereas if 10 percent of the inventory eventually reaches groundwater, some cleanup may be necessary. Therefore, an estimate of the initial inventory that may ultimately reach groundwater is important in determining the need for site cleanup. The study also showed that better definition of  $K_d$ ,  $K_a$ , and porosity would aid in refining estimates of the compliance boundary concentrations. Truex et al. (2001) concluded, "...if 1% of the discharged CT [carbon tetrachloride] is all that ever reaches groundwater, then it is likely the highest concentration of CT to arrive at the compliance boundary will not exceed the compliance concentration."

### **LLBG Disposal of Carbon Tetrachloride**

The presence of carbon tetrachloride in the aquifer underlying the 200 West Area is a direct result of the disposal of liquid waste streams containing carbon tetrachloride. The mean value inventory of carbon tetrachloride shows approximately 813,000 kg being released to liquid discharge sites in the 200 West Area. For comparison, all of the carbon tetrachloride in HSW is reported to be in "stored" solid waste; none is reported in "buried" solid waste, and the total inventory reported to be stored through 1997 was approximately 5000 kg. Storage is taking place in the radioactive mixed waste storage facilities (primarily CWC) and in retrievably stored TRU waste trenches in the 218-W-3A, 218-W-4B, and 218-W-4C LLBGs. While there is no record of past disposals, some carbon tetrachloride might have been disposed of in HSW; however, it is likely that the amount, its rate of release, and its potential impact on groundwater would not be substantial compared with that of past releases to liquid discharge facilities.

(a) Stochastic Analysis: Set of calculations performed using values randomly selected from a range of reasonable values for one or more parameters; in contrast, see deterministic analysis. In the HSW EIS, the median result from a set of stochastic calculations was reported.

(b) Deterministic Analysis: A single calculation using only a single value for each of the model parameters. A deterministic system is governed by definite rules of system behavior leading to cause and effect relationships and predictability. Deterministic calculations do not account for uncertainty in the physical relationships or parameter values.

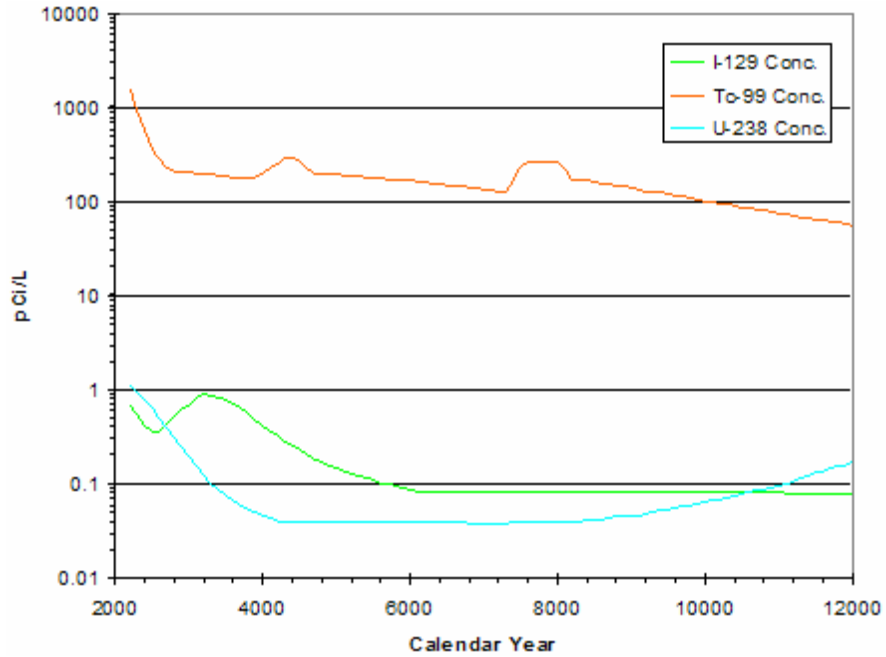
The stochastic analysis included 25 realizations. Each realization represents a possible combination of the uncertain parameters. Using a cumulative performance measure, such as cumulative dose at a point of interest, a single realization can be identified as the median response for the stochastic problem. The single deterministic calculation was performed using the median value for each input parameter. Results of the 25 stochastic simulations, with the median result case highlighted, are provided in Volume II, Appendix L. The result of the deterministic calculation using median inputs is reported in this section as well as in Volume II, Appendix L for comparison to the stochastic cases. For additional information on the SAC calculation process, see Volume II, Appendix L to this EIS and the initial assessment report (Bryce et al. 2002). The SAC is the next generation methodology intended to update and improve the 1998 Composite Analysis completed by Kincaid et al. (1998). Using the dose predicted in the ILAW performance assessment (Mann et al. 2001) the influence of ILAW disposal has been added to that predicted in the initial assessment median-inputs case simulated with SAC. Thus, the cumulative impact shown below for selected points is achieved by superimposing the published ILAW impact on the simulated initial assessment results. The inventories simulated using the SAC tool for this EIS are shown in Table L.1 in Volume II, Appendix L and represent the combination of solid waste, liquid discharge and unplanned release, tank waste, and commercial low-level waste inventories addressed in the cumulative assessment.

#### **1-km Line of Analysis**

A line of analysis approximately 1 km from an operational area or waste disposal site was used in the 1998 composite analysis (Kincaid et al. 1998), the initial assessment completed with the SAC (Bryce et al. 2002), and in the simulations supporting this HSW EIS. The travel distance between the source and the uptake location is consistent with the groundwater model grid (that is, 375 m) and the longitudinal dispersivity (that is, 95 m) used in the sitewide groundwater model. In general, the rule of thumb for selecting an appropriate longitudinal dispersivity is to use approximately 10 percent of the mean travel distance of interest. A 1-km travel distance implies a 100-m longitudinal dispersivity. To control model stability and artificial dispersivity, the model grid Peclet number (that is, grid spacing/longitudinal dispersivity = 375 m/95 m) is typically selected to be no greater than 4 for finite element models. The existing model for the cumulative impacts was not configured to produce results at a 100-m travel distance. To achieve results at a 100-m line of analysis for the cumulative impacts would require development of a local-scale model based on an approximate grid size of 40 m and longitudinal dispersivity of 10 m.

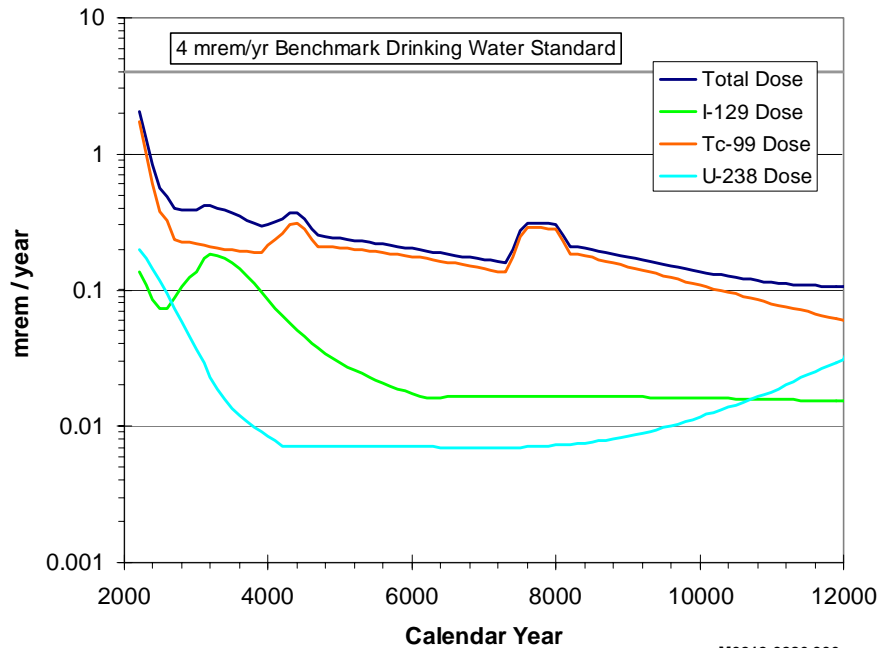
Concentration profiles over time for technetium-99, iodine-129, and uranium from all Hanford sources at a line of analysis approximately 1 km (0.6 mi) southeast of the 200 East Area are shown in Figure 5.44. Maximum concentrations for each of the radionuclides occur in the near term.

Concentrations of technetium-99, iodine-129, and uranium are 1600, 0.90, and 1.1 pCi/L, respectively. The technetium-99 and iodine-129 concentrations are above or near the benchmark drinking water standards of 900 pCi/L and 1 pCi/L, respectively. The uranium concentration, approximately 3.3 µg/L, is below its benchmark drinking water standard of 30 µg/L. The cumulative impact for technetium-99, iodine-129, and uranium from all Hanford sources is provided in Figure 5.45. This is the annual dose



M0212-286.905  
R1 HSW EIS 08-08-03

**Figure 5.44.** Concentrations of Technetium-99, Iodine-129, and Uranium in Groundwater Southeast of the 200 East Area from All Hanford Sources



M0212-0286.906  
R2 HSW EIS 09-11-03

**Figure 5.45.** Hypothetical Drinking Water Dose from Technetium-99, Iodine-129, and Uranium in Groundwater Southeast of the 200 East Area from All Hanford Sources

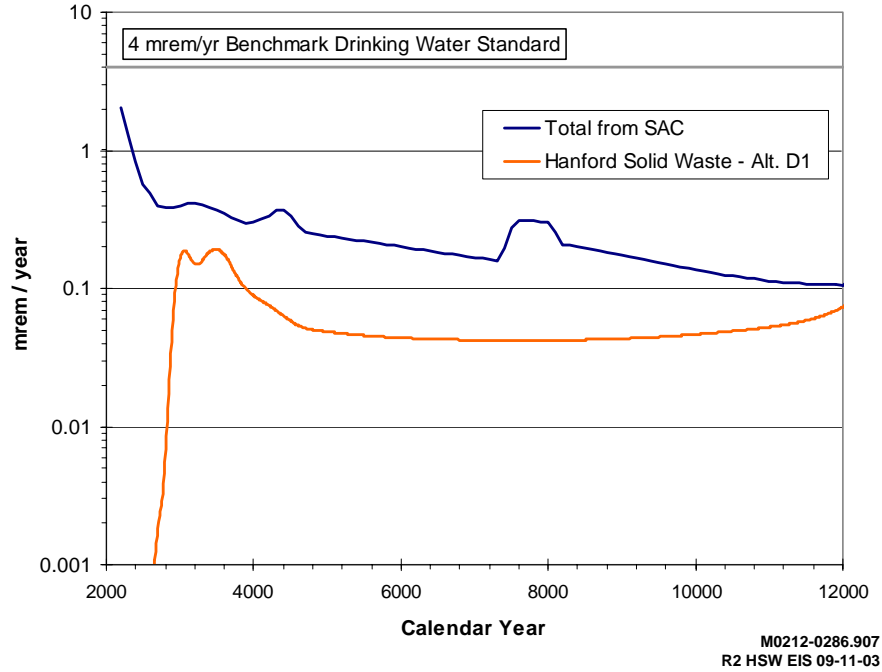
resulting from a 2-L/d drinking water scenario for each of the radionuclides. The values of maximum dose for technetium-99, iodine-129, and uranium corresponding to the maximum concentrations are 1.7, 0.18, and 0.20 mrem/yr.

The annual dose exhibits a peak of approximately 2 mrem/yr. This peak appears to be related to releases from past liquid discharge sites in the 200 East Area. Additional, but lower, peaks of approximately 0.4 mrem/yr appear in approximately years 4400 and 7600. Releases of technetium-99 from HSW disposal facilities in the 200 West Area are responsible for the peak in approximately year 4400. Tank waste residuals releasing technetium-99 in the 200 East Area from a 1-percent residual volume and a salt cake waste are responsible for the last peak. The underlying long-term dose declines to 0.1 mrem/yr by 10,000 years post closure. This dose is related to long-term releases from HSW and other miscellaneous waste, which, when combined, account for approximately 0.07 mrem/yr, and from ILAW, which accounts for approximately 0.04 mrem/yr.

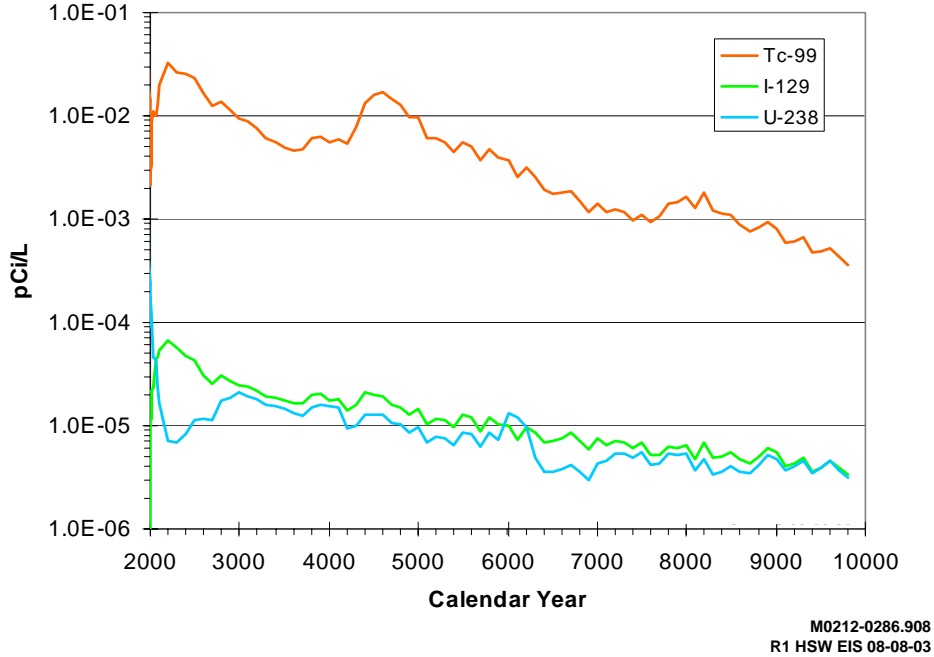
Based on uncertainty in the groundwater conceptual model and resulting direction of groundwater flow, the ILAW contribution to the cumulative result may be approximately four times larger when groundwater flows to the northeast rather than the southeast. The resulting cumulative 2-L/d drinking water dose from ILAW for technetium-99, iodine-129, and uranium would be approximately 0.2 mrem/yr at 10,000 years post closure for this northeast groundwater flow case. Somewhat higher contributions than shown here from HSW and other sources (that is, 0.07 mrem/yr) may also occur because of uncertainty in the groundwater conceptual model used in the SAC; however, groundwater model uncertainty as it relates to the HSW contributions is addressed in Section 5.3 and Volume II, Appendix G. It should be noted that the ILAW release and associated dose impacts play a role in the last several thousand years only and do not substantially influence the peaks that occur earlier.

The cumulative dose from all Hanford sources and that portion attributed to solid waste at the line of analysis southeast of the 200 East Area are shown in Figure 5.46. Differences in the two curves (that is, the slope of the curves) are attributed to somewhat different distribution coefficient ( $K_d$ ) values used in the simulation of HSW EIS groundwater impact analysis and in this cumulative assessment. The more rapid release and migration of uranium in the evaluation of solid waste disposal alternatives enables uranium to influence the long-term solid waste contribution between 8,000 and 12,000 A.D. This uranium influence is not seen in the initial assessment simulated with SAC because of the use of somewhat higher distribution coefficients to represent median or central tendency behavior. More details can be found later in this section.

Figure 5.47 shows the concentrations of technetium-99, iodine-129, and uranium from all Hanford sources from Columbia River water at the City of Richland pumping station. This location is downriver from all groundwater plumes of Hanford origin, and reveals the substantial dilution and dispersion that occurs because of the relatively large discharge of the Columbia River as compared with that of the unconfined aquifer underlying Hanford. Although groundwater simulations continued through the year 12,050 A.D. (10,000 years post closure; see Figure 5.47), the river simulations were terminated at the year 9900 A.D. due to the software design constraints of the river model. Thus, river model forecasts are not available for the final 2000 years of the 10,000-year post-closure period. However, as is apparent from



**Figure 5.46.** Hypothetical Total Drinking Water Dose from Groundwater for All Hanford Sources and the Hanford Solid Waste Contribution at the Line of Analysis Southeast of the 200 East Area



**Figure 5.47.** Concentrations of Technetium-99, Iodine-129, and Uranium in the Columbia River at the City of Richland Pumping Station from All Hanford Sources



the simulation results achieved, trends seen in the groundwater system near the Central Plateau appear somewhat later and at much reduced concentrations in the Columbia River at the City of Richland location.

A corresponding plot of the drinking water dose for technetium-99, iodine-129, and uranium is provided in Figure 5.48. While having a much more variable appearance caused by river discharge variability, the peaks seen in technetium-99 plots at the 200 East Area location are also present in Figure 5.48. Dose from Hanford-origin uranium and iodine-129 also exhibits a temporal variability caused by variability in Columbia River discharge. However, the peaks are subdued and delayed because these elements are sorbed and migrate more slowly than groundwater and non-sorbed elements, such as technetium. Concentration and annual dose values are approximately five orders of magnitude lower at the city of Richland compared with those predicted at the 200 East Area.

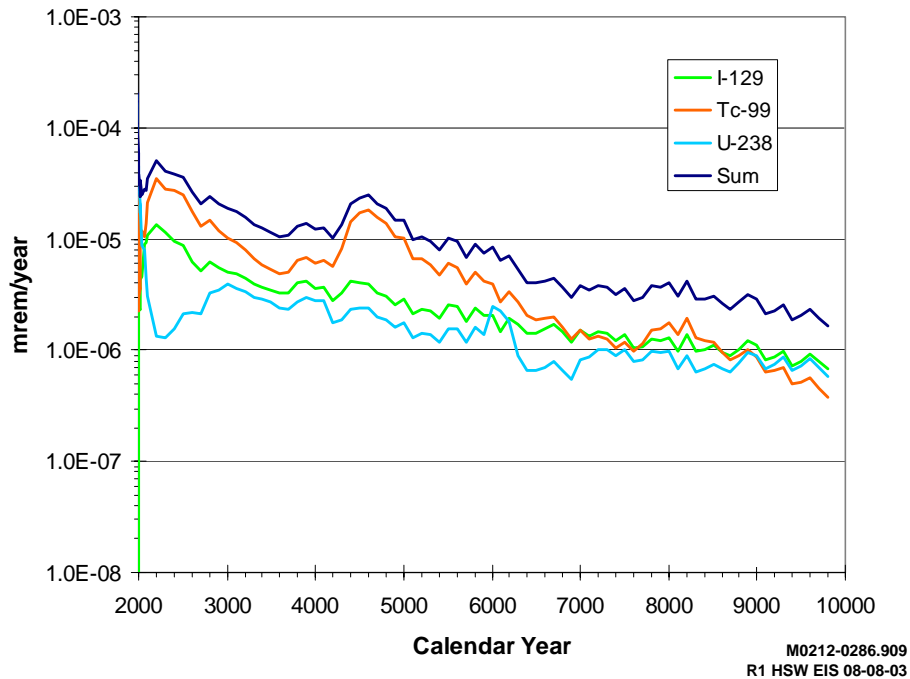
Figure 5.48 reveals the drinking water dose to a human from technetium-99, iodine-129, and uranium using water concentrations calculated near the City of Richland pumping station in the Columbia River never gets above  $1.0 \times 10^{-4}$ , or 0.0001, mrem/yr in the median inputs analysis. This location is downriver from all groundwater plumes of Hanford origin. The peak median dose from technetium-99 for the year 2000 through 9900 A.D. was approximately  $3.5 \times 10^{-5}$ , or 0.000035, mrem/yr. For the same period, the peak median dose from iodine-129 was approximately  $1.5 \times 10^{-5}$ , or 0.000015, mrem/yr. For uranium, the peak median dose was approximately  $5 \times 10^{-5}$ , or 0.00005, mrem/yr. These peaks occur at different times based on the sorption of each radionuclide. These results of dose analyses are presented as annual radiation dose.<sup>(a)</sup>

Figure 5.49 shows the cumulative dose from all Hanford sources and that portion attributed to solid waste at the City of Richland pumping station. By the end of this analysis, 8000 years after site closure, the contribution from solid waste will be increasing slightly while the cumulative dose from all sources will be decreasing, and the overall dose from the three radionuclides is estimated to be less than  $1 \times 10^{-5}$  mrem/yr for the median-inputs case. An examination of the contribution of solid waste compared with the total annual dose reveals that initially less than one percent of the total is from solid waste; by calendar year 3500 the solid waste contribution will be approximately 6 percent of the total dose, and by calendar year 10,000 the solid waste contribution will be approximately 20 percent of the total dose. However, the contribution from solid waste is never above  $1.0 \times 10^{-6}$ , or 0.000001, mrem/yr at the City of Richland pumping station.

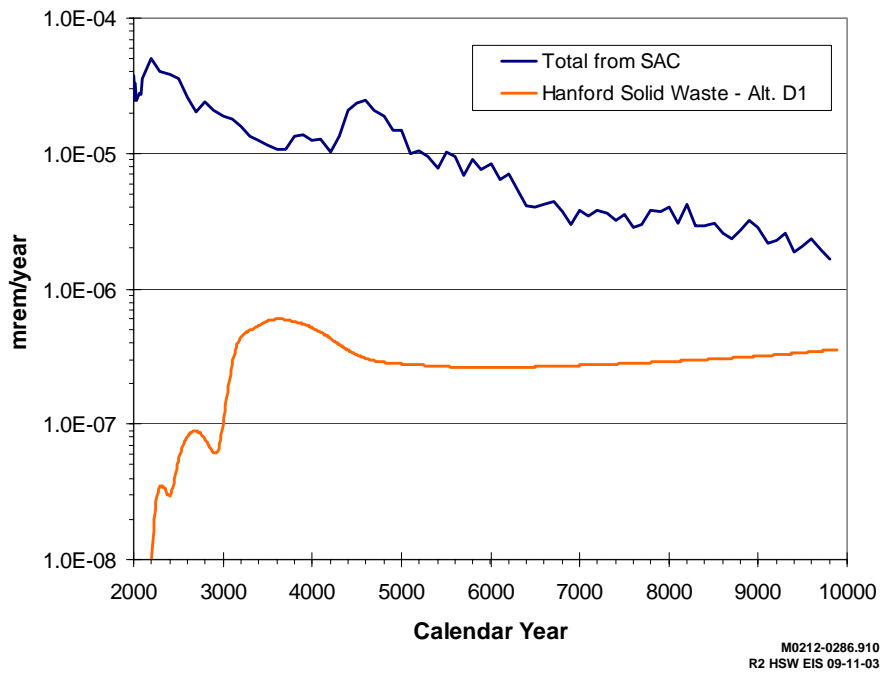
The stochastic capability of SAC was employed to evaluate the relative role in overall release of different waste types including solid waste, past liquid discharges, tank wastes, and facilities including canyon buildings. The variability in the stochastic results is due to variability in the inventory, release,

---

(a) The National Council on Radiation Protection and Measurements continues to hold that a dose of 1 mrem/yr is a dose "below which efforts to reduce the radiation exposure to the individual are unwarranted (Section 17 of NCRP 1993)" (NCRP 2002). Regardless, in this HSW EIS, doses are reported as calculated, however small they may be. Thus doses will be seen that are several to many orders of magnitude below 1 mrem/yr, and while these may be useful for comparative purposes, they should not be construed as having any physical meaning in terms of detriment to health.



**Figure 5.48.** Drinking Water Dose from Technetium-99, Iodine-129, and Uranium in the Columbia River at the City of Richland Pumping Station from All Hanford Sources



**Figure 5.49.** Hypothetical Total Drinking Water Dose from All Hanford Sources and the Hanford Solid Waste Contribution in the Columbia River at the City of Richland Pumping Station

and transport of technetium-99, iodine-129, and uranium. The human dose calculations use fixed inputs. These results include all waste releases (for example, releases from cribs, ponds, solid waste, past tank leaks, future tank losses, tank residuals, unplanned releases) that were considered in the initial assessment performed by Bryce et al. (2002). For reasons discussed previously, ILAW was analyzed separately and the results were added to the SAC analysis. The melters and naval reactor compartments would not contribute to the totals within 10,000 years (see the first footnote in Section 5.14.6.3 regarding ILAW, melters, and navy wastes).

In the SAC simulation, cumulative releases to groundwater from HSW, excluding ILAW disposed of in the Central Plateau, ranged from approximately 300 to 450 Ci for technetium-99 over the 10,000-year analysis period. This compares with releases to groundwater ranging from approximately 1500 to 2300 Ci of technetium-99 for all Hanford wastes except ILAW. Thus, the contribution to technetium-99 releases to groundwater from HSW, excluding ILAW, would amount to at most 20 percent of the cumulative release from all Hanford sources. The ILAW cumulative release of technetium-99 for the base case (Mann et al. 2001) used in this analysis was approximately 86 Ci by the end of the 10,000-year, post-closure period. Thus, the contribution from HSW, including ILAW, for technetium-99 would amount to, at most, 25 percent of the cumulative release. The majority of technetium-99 releases from wastes other than ILAW were predicted to occur from liquid discharge sites (cribs, ponds, trenches) used in the past and from unplanned releases on the plateau and from off-plateau waste sites.

For uranium, releases from HSW, excluding ILAW, to groundwater are much lower in the SAC simulation. No realizations showed any release of uranium to groundwater from these wastes in the 200 East Area, and only 5 of 25 realizations show any release of uranium to groundwater from these wastes in the 200 West Area. Thus, in an average (or median) sense, deposits of HSW, excluding ILAW, would release no uranium to groundwater over the 10,000-year period of analysis. This compares with a median release of approximately 84 Ci and a range of releases to groundwater from the 25 realizations of between approximately 10 and 300 Ci of uranium for all Hanford wastes except ILAW. Of the five stochastic realizations exhibiting non-zero uranium release from HSW, excluding ILAW, in the 200 West Area, the cumulative release ranged from 0 to approximately 90 Ci. Hence, the contribution of HSW, excluding ILAW, to overall uranium release to groundwater lies between 0 and 90 Ci, but the majority of the realizations showed no release. As a consequence, the contribution of HSW, excluding ILAW, to uranium releases to groundwater would amount to between 0 and 30 percent of the cumulative release from all Hanford sources except ILAW, and likely would be zero. The majority of uranium releases from wastes other than ILAW was predicted to occur from liquid discharge sites (for example, cribs, ponds, and trenches) used in the past and from unplanned releases on the plateau and from off-plateau waste sites. The ILAW cumulative release of uranium for the base case (Mann et al. 2001) was less than 1 Ci by the end of the 10,000-year post-closure period. Accordingly, the contribution from HSW including ILAW would amount to about 1 percent of the cumulative median release of uranium from all Hanford sources after 10,000 years.

Cumulative releases to groundwater from HSW disposed of in the Central Plateau, excluding ILAW, ranged from 0 to approximately 2.2 Ci for iodine-129 over the period of analysis. This compares with releases to groundwater ranging from approximately 0.1 to 8.8 Ci of iodine-129 for all Hanford wastes except ILAW. The contribution to iodine-129 releases to groundwater from HSW, excluding ILAW,

would amount to, at most, 25 percent of the cumulative release from all Hanford sources. With the exception of commercial low-level radioactive waste, iodine-129 releases from solid waste disposal facilities were predicted to be on par with those from tank sites and only half of those from liquid discharge and unplanned release sites. The ILAW cumulative release of iodine-129 for the base case (Mann et al. 2001) was approximately 0.07 Ci by the end of the 10,000-year post-closure period. This is a nominal amount given the existing iodine-129 plume in groundwater and the forecast releases of other waste forms.

The SAC cumulative and HSW EIS alternative-specific (see Volume II, Appendix G) simulations of uranium migration and fate that appear in this EIS differ in the relative roles of technetium-99 and uranium at times nearing the end of the 10,000-year, post-closure period analyzed because distribution coefficients for uranium in the two analyses differ. The SAC produces results where technetium-99 is the dominant radionuclide throughout the post-closure analysis period. However, the HSW EIS alternative-specific approach, which is applied to generate comparative analyses of the 33 alternative groups, predicts that uranium becomes dominant towards the end of the post-closure analysis. The distribution coefficients of the linear sorption isotherm model were assigned a value of 0.6 mL/g in the HSW EIS alternative-specific approach and a value of 3 mL/g for release models and 0.8 mL/g for transport models in the median-value SAC simulation. The value used in the HSW EIS alternative-specific approach is a more conservative, lower value that causes more rapid migration at higher contaminant levels. The values used in the SAC are median values somewhat higher than the conservative value, and they result in slower migration and lower contaminant concentrations. As a result, the SAC assessment predicts that the median response will be dominated by technetium-99 with uranium making a contribution in the latter portion of the 10,000-year, post-closure period. The HSW EIS alternative-specific simulation of alternative groups shows uranium dominating in the last few thousand years because its mobility is greater in that model. The range of  $K_d$  applied for uranium in the stochastic SAC model includes the nominal value used in the HSW EIS alternative-specific simulation, and some realizations of the stochastic model exhibit the greater uranium mobility and contribution to dose seen in the HSW EIS alternative-specific results. However, for the purpose of reporting cumulative impacts using the SAC assessment, the median stochastic result is provided.

Leaching of radionuclides from wastes disposed of in HSW disposal facilities and their transport through the vadose zone, to groundwater, and then to the Columbia River also would lead in the long term to small additional collective doses to downstream populations. The collective dose from HSW for all action alternatives was calculated to range from about 0.2 person-rem for the total population of the cities of Richland, Kennewick, and Pasco, Washington, to about 0.6 person-rem for a hypothetical population of a city the size of Portland, Oregon, that might draw water from the Columbia River in the vicinity of Portland. No LCFs would be inferred from such population doses (see Section 5.11.2.1).

To provide some perspective on the preceding material on groundwater impacts that might be associated with disposal of HSW, impacts as a result of using water from various sources for the three principal groundwater related scenarios—drinking-water dose, dose to the resident gardener, and dose to the resident gardener with a sauna/sweat lodge—are presented in Table 5.153.

**Table 5.153.** Radiological Impacts (principally from uranium) in Various Sources of Water on, Near, or Downstream of the Hanford Site

Source of Water	Dose Scenario		
	Drinking Water (2 L/day) mrem/yr	Resident Gardener mrem/yr	Resident Gardener with Sauna/Sweat Lodge <sup>(a)</sup> mrem/yr
<b>Sources of Water not Impacted by Hanford Groundwater</b>			
Portland, OR municipal (Bull Run) water <sup>(b)</sup>	0.006	0.007	6
Columbia River upstream of the Hanford Site at Priest Rapids <sup>(c)</sup>	0.092	0.11	96
Yakima River at Benton City <sup>(d)</sup>	0.19	0.23	200
Yakima Barricade well <sup>(e)</sup>	0.45	0.54	470
Well - Mathews Corner, Franklin Co. <sup>(f)</sup>	1.3	1.6	1,400
Benton City municipal water system <sup>(g)</sup>	2.6	3.1	2,700
<b>Hanford Groundwater and Sources of Water Downgradient from Hanford Groundwater</b>			
Highest doses attributable to HSW - hypothetical wells in the 200 Areas - action alternatives <sup>(h)</sup>	0.42	1.4	200
Highest doses attributable to HSW - hypothetical wells near the Columbia River - action alternatives <sup>(h)</sup>	0.064	0.22	7.4
Highest doses attributable to HSW - hypothetical wells in the 200 Areas - No Action Alternative <sup>(h)</sup>	0.98	3.3	480
Highest doses attributable to HSW - hypothetical wells near the Columbia River - No Action Alternative <sup>(h)</sup>	0.039	0.12	14
Columbia River downstream of the Hanford Site at the Richland pump house <sup>(c)</sup>	0.10 <sup>(i)</sup>	0.12	110 <sup>(i)</sup>
Columbia River - Franklin County across from the Richland pump house <sup>(k)</sup>	0.15	0.18	160
<p>(a) Water containing natural uranium (with 1:1 ratio of U-234 to U-238) at the MCL of 30 µg/L would yield about 4,000 mrem/yr in the sauna/sweat lodge scenario. Where the ratio is larger than 1, as is often the case for groundwater, the dose would be higher than 4,000 mrem/yr.</p> <p>(b) July–December 1977 composite sample (Cothorn and Lappenbusch 1983). In 1985 Portland began to use the Columbia South Shore well field to supplement their water supply. It was used exclusively for a few days in 1996 because of turbidity in Bull Run water (see discussion at <a href="http://www.water.ci.portland.or.us/groundwater.htm">http://www.water.ci.portland.or.us/groundwater.htm</a>). Because of the high rainfall and recharge in the region of the well field, it is believed unlikely that contamination of Hanford origin could have any impact on the quality of Portland municipal water.</p> <p>(c) 6-year average measurement (Poston et al. 2002).</p> <p>(d) Single measurement sample collected March 2003.</p> <p>(e) 7-year average measurement. Hanford Environmental Information System Database. Fluor Hanford, Inc.</p> <p>(f) 5-year average measurement. Hanford Environmental Information System Database. Fluor Hanford, Inc.</p> <p>(g) Average of 10 measurements 1959 (Junkins et al. 1960), single measurement 2003.</p> <p>(h) Values given are exclusive of background which may be approximated by the Yakima Barricade values.</p> <p>(i) To which HSW was determined to add up to about <math>6.0 \times 10^{-7}</math>, or 0.0000006, mrem/yr from Tc-99 and I-129 in about the year 4000 A.D.</p> <p>(j) To which HSW was determined to add less than 0.001 mrem/yr from uranium in the year 12,000 A.D.</p> <p>(k) Poston et al. (2002).</p>			

Of interest are the relatively large doses to the gardener with sauna/sweat-lodge even when the drinking water dose is less than the DOE 4-mrem/yr benchmark drinking water standard. This is attributed to the inhalation of uranium in the hot, moist air of the sauna/sweat lodge. Also of interest is the dose in this scenario for naturally occurring uranium is about twice that for doses associated with HSW for like masses of material. This difference is attributed to the reduction in the ratio of uranium-234 to uranium-238 in Hanford solid waste compared with that occurring naturally.

#### 5.14.6.4 Transportation

Transportation impacts associated with transporting radioactive wastes and materials including that to and from the Hanford Site have been addressed in other NEPA documents. Table 5.154, based on DOE (2002a) and this EIS, provides cumulative impact information from those analyses and analyses performed for the HSW EIS.

**Table 5.154.** Cumulative Transportation Impacts

Category	Workers LCFs <sup>(a)</sup>	General Population, LCFs <sup>(a,b)</sup>	Traffic Fatalities
<b>Representative Past and Reasonably Foreseeable Actions (Excluding HSW) Involving Transport of Radioactive Materials</b>			
Historical DOE shipments	0 (0.20)	0 (0.14)	Not Listed
Sodium-bonded Spent Nuclear Fuel	0 (<0.001)	0 (<0.001)	0 (<0.001)
Surplus plutonium disposition	0 (0.036)	0 (0.040)	0 (0.053)
Waste Management PEIS	10	12	36
Waste Isolation Pilot Plant	0 (0.47)	4 (3.5)	5
Cruiser and submarine reactor plant disposal	0 (0.003)	0 (0.003)	0 (0.0095)
Spent nuclear fuel and high-level waste – Oregon & Washington	0 (<0.055)	0 (<0.021)	0 (0.049)
General transport of radio-pharmaceuticals, commercial LLW, etc.	198	174	22
<b>Transport of Hanford Solid Wastes</b>			
Alternative Groups A, C, D, and E – onsite, nearby treatment, and treatment at ORR	0 (0.038)	0 (0.43)	0 (0.084)
Alternative Group B – onsite and nearby treatment	0 (0.064)	1 (0.86)	0 (0.068)
No Action Alternative – onsite	0 (0.012)	0 (0.14)	0 (0.050)
Incoming and offsite shipments (Upper Bound waste volume) <sup>(c)</sup>	1 (0.74)	8 (8.2)	2 (2.3)
Incoming and offsite shipments, WA and OR impacts only – included in the above (Upper Bound waste volume)	0 (0.096)	1 (1.1)	1 (0.52)
<b>TRU Waste Shipments from Hanford to WIPP</b>			
Alternative Groups A – E (Upper Bound waste volume)	0 (0.30)	5 (4.8)	1 (0.56)
No Action Alternative	0 (0.15)	2 (1.6)	0 (0.28)
(a) Assumes 6 LCFs per 10,000 person-rem.			
(b) For the HSW EIS, the numbers consist of inferred fatalities from radiation exposure and vehicular emissions.			
(c) In the final HSW EIS, all offsite transport is addressed, including the entire transportation route for offsite waste sent to Hanford.			

In addition, this EIS presents a discussion of transportation of wastes that are within the scope of this HSW EIS to and from the Hanford Site (see Section 5.8).

The information in Table 5.154 indicates that the cumulative transportation impacts associated with any of the HSW EIS alternative groups are small relative to transport of radioactive material in general. For perspective, it may be noted that several million traffic fatalities from all causes would be expected nationwide during the period 1943 to 2047 (DOE 2002a).

#### **5.14.7 Worker Health and Safety**

The cumulative Hanford worker dose since the startup of activities at Hanford is about 90,000 person-rem (DOE 1995), to which would be added approximately 1000 person-rem from spent fuel management (DOE 1996a); 8200 person-rem from tank waste remediation (DOE and Ecology 1996); 730 person-rem for Plutonium Finishing Plant stabilization (DOE 1996b); and 765 to 873 person-rem through the year 2046 from the management of Hanford solid waste, ILAW, and WTP melters (Hanford Only waste volume for Alternative Group A to either the Hanford Only or Lower Bound volume for the No Action Alternative, [see Section 5.11]). Thus, for about 100 years of Hanford operations, approximately 40 LCFs would be inferred among workers, none of which would be attributable to Hanford solid waste program activities. Because of DOE restrictions on worker dose and rigorous application of the ALARA principle, the cumulative collective worker dose associated with all future Hanford Site restoration activities would not be expected to add substantially to the collective worker dose to date.

## 5.15 Irreversible and Irretrievable Commitments of Resources

Irreversible and irretrievable commitments of resources (42 USC 4321) that likely would result from implementing any of the alternative groups or the No Action Alternative are addressed in this section. An irreversibly committed or irretrievable resource is one that is irreplaceably consumed and is non-renewable, is in limited supply, or cannot be replenished.

Implementation of any of the alternative groups would result in the irretrievable use of fossil fuels in construction activities, transport of materials and waste, and treatment processes. Bentonite clay, which is a limited resource, also would be committed. Although steel is not in limited supply, the steel used in drums and rebar essentially would be irretrievable. Land areas used for disposal facilities also would be irretrievably committed.

DOE anticipates that current contamination would preclude the beneficial use of groundwater underneath portions of the Hanford Site for the foreseeable future. It is assumed that the tritium and iodine-129 groundwater plumes would exceed the drinking water standards for the next several hundred years.

Within a few hundred years after disposal of wastes evaluated in the HSW EIS, some mobile radionuclides from the wastes would reach the vadose zone surrounding disposal areas and groundwater beneath the Hanford Site. Results of computer simulations (as presented in Sections 5.3 and 5.11) predict that levels of these contaminants in groundwater would be below DOE benchmark drinking water standards at 1 kilometer and below the DOE all-pathway limit for the hypothetical onsite resident gardener without a sauna or sweat lodge.

However, due to uncertainties in inventory estimates and mobility parameters, DOE considers groundwater underneath portions of the Hanford Site that is proximate to, or downgradient from, waste sites at Hanford to be irretrievably committed. At a minimum, depending on the location and time of interest, concentrations of radionuclides in groundwater might be such that it would be necessary to place some restrictions on groundwater usage (for example, restrictions on use of groundwater for saunas or sweat lodges late in the 10,000-year period of analysis; see Section 5.11 and Volume II, Appendix F).

The quantities of non-renewable resources that would be irreversibly or irretrievably committed are listed in Table 5.155.

In addition, geologic resources that form the above-grade cover for the waste disposal sites, as shown in Table 5.18 in Section 5.4, would, within the intent of the disposal site closure, be considered irreversibly committed.



**Table 5.155.** Irreversible and Irretrievable Commitments of Selected Resources by Alternative Group with ILAW

Resource (Units) <sup>(a)</sup>	Diesel <sup>(b)</sup> (m <sup>3</sup> )	Gasoline (m <sup>3</sup> )	Propane (t)	Bentonite Clay (t)	Steel <sup>(c)</sup> (t)	Land (ha)
<b>Alternative Group A</b>						
Hanford Only	132,900	260	12,700	13,900	1,720	169
Lower Bound	132,900	260	12,700	13,900	1,870	170
Upper Bound	133,700	270	19,300	18,200	2,280	178
<b>Alternative Group B</b>						
Hanford Only	136,600	340	23,500	33,600	1,800	187
Lower Bound	136,700	340	23,500	33,600	1,950	189
Upper Bound	140,600	430	38,300	57,600	2,380	210
<b>Alternative Group C</b>						
Hanford Only	65,900	260	12,700	13,900	1,720	151
Lower Bound	65,900	260	12,700	13,900	1,870	152
Upper Bound	66,700	270	19,300	18,200	2,280	160
<b>Alternative Group D</b>						
Hanford Only	65,900	260	18,800	13,900	1,710	150
Lower Bound	65,900	260	20,300	13,900	1,870	150
Upper Bound	66,700	270	27,800	18,200	2,280	155
<b>Alternative Group E</b>						
Hanford Only	65,900	260	18,800	12,800	1,710	150
Lower Bound	65,900	260	20,300	13,900	1,870	150
Upper Bound	66,700	270	27,800	18,200	2,280	155
<b>No Action Alternative</b>						
Hanford Only	188,600	48	3,560	0	59,100	273 <sup>(d)</sup>
Lower Bound	188,700	50	3,560	0	59,200	275 <sup>(d)</sup>
<p>(a) Conversion factors: 1 m<sup>3</sup> (capacity) = 260 gal; 1 m<sup>3</sup> (volume) = 1.3 yd<sup>3</sup>; and 1 t (metric tonne) = 1.1 tons.</p> <p>(b) Includes 120,100 m<sup>3</sup> for ILAW in Alternative Groups A and B; 53,100 m<sup>3</sup> for ILAW in Alternative Groups C, D, and E; and 183,400 m<sup>3</sup> for ILAW in the No Action Alternative.</p> <p>(c) Includes 1000 t for ILAW in Alternative Groups A through E and 33,200 t for ILAW in the No Action Alternative.</p> <p>(d) Includes land committed to storage of waste at CWC.</p>						

## 5.16 Relationship Between Short-Term Uses of the Environment and the Maintenance or Enhancement of Long-Term Productivity

For purposes of the HSW EIS, short-term use is defined to encompass the period through the year 2046; long-term productivity is defined to encompass the period following 2046.

The principal objective of Alternative Groups A through E (whether for the Hanford Only, Lower Bound, or Upper Bound waste volume)—namely, permanent disposal of LLW, MLLW, and ILAW at Hanford—does not involve the short-term use of the environment in the usual sense.<sup>(a)</sup> In addition, TRU waste is being shipped from Hanford to WIPP. Implementation of any of these alternative groups is intended to result in permanent disposal by below-grade land burial, followed by backfilling to grade, and capping with above-grade Modified RCRA Subtitle C Barriers. For all practical purposes, the LLBGs and the vadose zone beneath and surrounding them have been and will continue to be dedicated to the isolation of radioactive and hazardous wastes from the environment. If selected, the disposal sites near the PUREX Plant, near the CWC, and at ERDF, including the vadose zone beneath and surrounding them, would be similarly committed. Thus these portions of the Hanford Site constitute perhaps the highest use in terms of long-term productivity.

In time, contaminants from past and proposed waste disposal on the Hanford Site would reach the groundwater and the Columbia River. Depending on the location and time of interest, concentrations of radionuclides in groundwater might be such that it would be necessary to place some restrictions on groundwater usage. When the contaminants reach the Columbia River, they will be in such small concentrations that they would pose no adverse impact on the long-term productivity of the Columbia River.

In time and with the absence of human activities, flora and fauna common to the Central Plateau in the past likely would re-occupy the surface areas above the disposed of waste, and the surface would probably be indistinguishable from nearby undisturbed areas. However, prudence would dictate invoking land-use covenants to prohibit future land disturbance by humans and to reduce the likelihood of inadvertent intrusion into a waste site or dispersal of contaminants for as long as institutional controls can be maintained.

In the No Action Alternative, similar restrictions would apply; however, no conclusion is made regarding short-term uses versus long-term productivity because about 59,000 m<sup>3</sup> (76,700 yd<sup>3</sup>) of waste would be stored until the year 2046, with no defined disposition path thereafter.

---

(a) An example of “usual sense” in this context would be a mining operation in which the acid mine drainage contaminates a nearby stream. In that case, the short-term mining operation likely would have adverse effects on the long-term productivity of the streams and river into which contamination flows.

## 5.17 Unavoidable Adverse Impacts

This section summarizes the potential unavoidable adverse impacts associated with implementing the HSW EIS alternative groups. Identified are those unavoidable adverse impacts that would remain after incorporating all mitigation measures that were included in the development of the EIS alternative groups. Potentially adverse impacts for each of the alternative groups are described in other portions of Section 5. In Section 5.18, additional practicable mitigation measures are identified that might further reduce the impacts described in this section.

In particular, unavoidable adverse impacts that would occur if Alternative Groups A, B, C, D, E, or the No Action Alternative were to be implemented are identified in the following sections.

### 5.17.1 Alternative Group A

Unavoidable adverse impacts associated with implementing Alternative Group A would include:

- commitment of about 168.5 ha (410 ac) of land for disposal of the Hanford Only waste volume to about 177.9 ha (440 ac) for the Upper Bound waste volume of LLW, MLLW, ILAW, and melters
- small additions of pollutants to the atmosphere as a result of operating heavy equipment during modification of the T Plant Complex and construction of additional burial trenches, operation of facilities, trench backfilling, obtaining materials for constructing Modified RCRA Subtitle C Barriers for disposal facilities and capping the sites, and from transportation of materials and wastes
- small increments in dose to workers and the public
- potential for a total of 23 to 75 transport accidents (Lower Bound to Upper Bound waste volumes for LLW, MLLW, TRU Waste, ILAW, and WTP melters) and 1 to 3 fatalities from those accidents
- potential for 5 to 9 inferred LCFs as a result of routine transport of waste to and from the Hanford Site
- potential for 17 transport accidents and 1 non-radiological fatality from transporting TRU waste to WIPP (none of these fatalities would be expected to occur in the states of Oregon or Washington)
- potential for one transport accident in Oregon and none in Washington involving receipt of waste from offsite generators and subsequent transport of the TRU waste to WIPP in the Lower Bound waste volume case and five transport accidents in Oregon and two in Washington in the Upper Bound waste volume case. One fatality might occur in Oregon in the Upper Bound waste volume case.
- eventual migration of mobile radionuclides such as technetium-99, iodine-129, and uranium isotopes to the groundwater and ultimately to the Columbia River, leading to very small additional radiation doses to downstream populations.

### 5.17.2 Alternative Group B

Unavoidable adverse impacts associated with implementing Alternative Group B essentially would be the same as those for Alternative Group A, except for the following differences:

- commitment of about 186.6 ha (460 ac) of land for disposal of the Hanford Only waste volume to 210.1 ha (519 ac) for the Upper Bound waste volume of LLW, MLLW, and ILAW
- small additions of pollutants to the atmosphere as a result of operating heavy equipment during construction of a new waste processing facility for treatment of some wastes
- potential for 1 less transport accident (total for either the Lower Bound or Upper Bound waste volumes for LLW, MLLW, TRU Waste, ILAW and WTP melters), with the potential for 1 to 2 fatalities from those accidents.

### 5.17.3 Alternative Group C

Unavoidable adverse impacts associated with implementing Alternative Group C essentially would be the same as those for Alternative Group A, except for the following difference:

- commitment of about 150.5 ha (370 ac) of land for disposal of the Hanford Only waste volume to 159.9 ha (390 ac) for the Upper Bound waste volume of LLW, MLLW, and ILAW.

### 5.17.4 Alternative Groups D and E (All Subalternatives)

Unavoidable adverse impacts associated with implementing Alternative Groups D and E essentially would be the same as those for Alternative Group A, except for the following difference:

- commitment of about 149.9 ha (370 ac) of land for disposal of the Hanford Only waste volume to 155 ha (383 ac) for the Upper Bound waste volume of LLW, MLLW, ILAW, and melters.

### 5.17.5 No Action Alternative

Unavoidable adverse impacts associated with implementing the No Action Alternative would include:

- storage of certain MLLW and TRU wastes and melters requiring additional land disturbance of about 66 ha (163 ac)
- commitment of about 148 ha (365 ac) of land for below-grade disposal of LLW, MLLW, and ILAW for the Hanford Only waste volume to about 149 ha (368 ac) for the Lower Bound waste volume
- small additions of pollutants to the atmosphere from operating heavy equipment during construction and operation of burial trenches, construction of additional CWC storage buildings, operation of facilities, and from transportation of materials and wastes

- small increments in dose to the public and potential for one radiological LCF to the workers
- eventual migration of mobile radionuclides such as technetium-99, iodine-129, and uranium isotopes to the groundwater and ultimately to the Columbia River, leading to very small additional radiation doses to downstream populations
- potential for a total of 10 to 13 transport accidents (Hanford Only to Lower Bound waste volumes for LLW, MLLW, TRU Waste, ILAW and WTP melters) and no fatalities from those accidents
- potential for 2 inferred LCFs as a result of routine transport of waste to and from the Hanford Site
- potential for 8 transport accidents and zero fatalities from transport of TRU waste to WIPP
- potential for up to 1 transport accident in Oregon and none in Washington from the transport of TRU waste to WIPP. No fatalities are expected in either case.

## 5.18 Potential Mitigation Measures

### Mitigation Measures

Mitigation measures as discussed in the following sections are those actions not already included in the alternative groups that could further reduce or avoid adverse impacts potentially resulting from waste management operations at Hanford.

As defined by regulation (40 CFR 1508.20), mitigation includes

- avoiding the impact altogether by not taking a certain action or parts of an action
- minimizing impacts by limiting the degree or magnitude of the action and its implementation
- rectifying the impact by repairing, rehabilitating, or restoring the affected environment
- reducing or eliminating the impact over time by preservation and maintenance operations during the life of the action
- compensating for the impact by replacing or providing substitute resources or environments.

This section describes mitigation measures that could avoid or reduce environmental impacts caused by Hanford solid waste management operations. Several mitigation measures have been built into the alternative groups addressed in the HSW EIS, including installation of barriers, installation of liners and leachate collection systems, treatment of MLLW to meet applicable LDRs, use of mobile units (APLs) to accelerate certification and shipment of TRU waste to WIPP, and in-trench grouting and use of HICs for Cat 3 LLW and MLLW. Additional measures would be reviewed and revised as appropriate, depending on the relevant actions to be taken at a facility, the level of impact, and other pertinent factors. Following the publication of the Record of Decision (ROD), a mitigation action plan would be prepared, if warranted, to address actions specific to the alternative group selected for implementation. That plan would be implemented as necessary to mitigate significant adverse impacts of solid waste management activities. Possible mitigation measures are generally the same for all alternative groups and are summarized in the following sections.

### 5.18.1 Pollution Prevention/Waste Minimization

DOE is implementing Executive Order 13148, *Greening the Government Through Leadership in Environmental Management* (65 FR 24595), and associated DOE orders or guidelines by reducing toxic chemical use; improving emergency planning, response, and accident notification; and encouraging the development and use of clean technologies. Program components include waste minimization, recycling, source reduction, and buying practices that prefer products made from recycled materials. The Pollution Prevention Program at the Hanford Site is formalized in a Hanford Site Waste Minimization and Pollution Prevention Awareness Program Plan (DOE-RL 2001b). The plan includes an overview of pollution prevention and waste minimization at Hanford, how the program is implemented at Hanford, and specific objectives and goals to be obtained.

The solid waste management activities have been and would continue to be conducted in accordance with this plan. Implementation of the pollution prevention and waste minimization plans would minimize the generation of secondary wastes.

### 5.18.2 Cultural Resources

In the HCP EIS (DOE 1999), the Central Plateau was designated for Industrial-Exclusive use and Area C was designated for Conservation (mining). The activities described in this HSW EIS would be consistent with those designations. To avoid loss of cultural resources during construction of solid waste management facilities on the Hanford Site, cultural resources surveys have been and would continue to be made of the areas of interest. If any cultural resources were discovered during construction, construction would be halted. The appropriate authorities would be notified so the find could be evaluated to determine its appropriate management or its effect on continuation of activities.

Because Area C is within the viewshed from Rattlesnake Mountain, operation of the borrow pit there might have an indirect effect on the characteristics that contribute to the cultural and religious significance of Rattlesnake Mountain to local tribes. However, at the end of borrow pit operations, the area would be restored to natural contours and revegetated (see Volume II, Appendix D). Additional information on aesthetic and scenic impacts of these activities is presented in Section 5.12.

Given the possibility for buried cultural resources, some methodology would likely be needed to observe the subsurface. Ground-penetrating radar, shovel testing, or backhoe testing might be appropriate, as would monitoring for cultural resources during construction. Depending on conditions of the area, the frequency of monitoring may range from continuous to intermittent to periodic.

### 5.18.3 Ecological Resources

In the HCP EIS (DOE 1999) the Central Plateau was designated for Industrial-Exclusive use and Area C was designated for Conservation (mining). Most ecological resources in the Industrial-Exclusive zone of the Central Plateau were destroyed or displaced during the 24 Command Fire or by previous disturbances of the area. However, the fire did not affect the 200 East Area. Consequently, the mature sagebrush (*Artemisia tridentata*) habitat in the candidate disposal site near the PUREX Plant, if selected, would be subject to mitigation under current DOE guidelines, as prescribed in the *Hanford Site Biological Resources Management Plan* (DOE-RL 2001a) and the *Hanford Site Biological Resources Mitigation Strategy* (DOE-RL 2003c). In addition, some other habitats and species found in the burned area would be subject to mitigation under existing biological conditions and current mitigation guidelines. These are the element occurrences (see Volume II, Appendix I) and purple mat (*Nama densum* var. *parviflorum*) found in Area C.

Volume II, Appendix I sets forth what the mitigation requirements for the above habitats/species would be if these were to be disturbed in their current condition under current mitigation guidelines. For example, disturbance of ground-nesting birds and their young could be avoided by limiting major construction during the nesting season, or loss of sensitive habitat could be mitigated by restoration of lower quality habitat or by preservation of similar high quality habitat in another location. This is done primarily for the purpose of comparison of impacts among the alternative groups. Current biological conditions and mitigation guidelines are appropriate for determining mitigation requirements for impacts that would occur in the near term. However, they are not suitable for judging mitigation requirements that would occur some years hence because habitats and species assemblages may change in time (for

example, fire-damaged habitats may recover), as might mitigation guidelines at Hanford. Consequently, the actual mitigation requirements for later activities will depend on the results of field surveys conducted just prior to initiating operations and the mitigation guidelines in effect at Hanford at that time.

#### **5.18.4 Water Quality**

No activities associated with the proposed action or alternative groups would result in direct discharges to surface water such as the Columbia River. Therefore, any impacts on water quality would result from waste disposal and the potential for contamination of groundwater and, ultimately, the river. Many of the activities associated with waste disposal incorporate mitigating measures as part of normal operations. For example, disposal practices include the use of a rain curtain, or placing interim soil covers over trenches and contouring the soil to minimize water infiltration through the waste. Disposal facilities are also maintained to minimize intrusion of plants and animals into the waste. Higher-activity wastes are disposed of in high-integrity containers or are grouted in place to reduce the release rates of contaminants to the surrounding soil. Use of liners and leachate collection systems in disposal facilities would afford the opportunity to take corrective actions if necessary during the time when the facility was actively monitored; however, such measures would not prevent groundwater contamination over the long term. Use of reactive barriers beneath disposal facilities has also been proposed to delay migration of contaminants. In addition, treating MLLW may delay and slow release of some contaminants. Capping the disposal facility provides a greater opportunity to minimize water infiltration and contaminant transport. Recent studies indicate there may be some benefit from early capping in reducing long-term contaminant concentrations in groundwater (Bryce et al. 2002).

DOE's approach is to protect groundwater through the Performance Assessment process. Disposal facility performance assessments are routinely reviewed to ensure that facilities meet requirements established in DOE Orders 435.1 and 5400.5 (DOE 2001b, 1993). Changes in the disposal facility waste acceptance criteria would be made if the review indicates that groundwater contamination could exceed applicable requirements. As a result, some waste could require further treatment (for example, macro-encapsulation) prior to disposal, or additional confinement such as disposal in high-integrity containers or by grouting the waste in place. The waste could also be disposed of at another facility where it would meet the waste acceptance criteria, or it could be stored until another method was found to treat or dispose of the waste. In no case would DOE knowingly dispose of waste in violation of applicable legal requirements.

#### **5.18.5 Health and Safety – Routine Operations**

It is not expected that the public would experience any adverse consequences from routine waste management activities. Current and anticipated design, construction, and operation of waste management facilities would incorporate the best available technology to control discharge of potentially hazardous materials to the environment.

Under routine operations, exposure of workers to radioactive or other potentially hazardous materials would be maintained within permissible limits and, further, would be reduced under the as low as



reasonably achievable (ALARA) principle. This principle involves formal analysis by the workers, supervisors, and radiation and or chemical protection personnel of the work in a hazardous environment to reduce exposure of workers to the lowest practicable level.

There is some potential for contamination reaching the affected environment from waste in LLBGs via uptake through deep roots by nuisance weeds such as Russian thistle (tumbleweeds). Before capping of LLBGs, herbicides could be used to control such weeds. After the LLBGs are capped, they could be planted with vegetative species (such as wheatgrass [*Agropyron* sp.]) that could, in effect, choke out the nuisance weeds and assist in evapotranspiration.

### **5.18.6 Health and Safety – Accidents**

Although the safety record for operations at Hanford and other DOE facilities is good, DOE-RL and all Hanford Site contractors have established emergency response plans to prepare for and mitigate the consequences of potential emergencies on the site (DOE-RL 1999). These plans were prepared in accordance with DOE orders and other federal, state, and local regulations. The plans describe action that will be taken to evaluate the severity of a potential emergency and the steps necessary to notify and coordinate the activities of other agencies having emergency response functions in the surrounding communities. The plans also specify the level at which the hazard to workers and the public is of sufficient concern that protective action should be taken. The site holds regularly scheduled exercises to help ensure that individuals with responsibilities in emergency planning are properly trained in the procedures that have been implemented to mitigate the consequences of potential accidents and other events. As necessary, Hanford Site emergency response plans would be updated to include consideration of new solid waste management facilities and activities.

### **5.18.7 Traffic and Transportation**

Transport of LLBG capping materials from the borrow pit in Area C across SR 240 to the 200 Areas was determined to have the potential for traffic congestion and accident hazards. As a consequence, an underground conveyor system could be used to move the materials to a staging area east of SR 240 and to minimize crossings of trucks and other equipment. Further, additional safety measures would be expected to take the form of dust control; restrictions on crossings to off-shift-change hours; signs and warning lights along SR 240 to the north, south, and well in advance of the crossing; and a traffic control light at the crossing itself.

Many measures to mitigate transportation impacts are incorporated into regulatory requirements for shipping hazardous materials. Shipment of hazardous materials is regulated by the U.S. Department of Transportation (DOT), and many states have established additional requirements. The DOT regulations for shipping hazardous materials can be found in the Hazardous Material Regulations (49 CFR 171-180), the Federal Motor Carrier Safety Regulations (49 CFR 390-397), and “Packaging and Transportation of Radioactive Material” (10 CFR 71). Other regulations and requirements for the shipment of radioactive materials can be found in DOE’s Radioactive Material Transportation Practices (DOE 2002b). These regulations address many specific subjects including shipper and carrier responsibilities, planning information, routing and route selection, notifications, shipping papers, driver qualifications and training,

vehicles and required equipment, equipment inspections, labeling (information on containers), placarding (information on the shipping vehicle), emergency planning, emergency notification, emergency response, and security.

DOE operates a Radiological Assistance Program with eight Regional Coordinating Offices staffed with experts available for immediate assistance in offsite radiological monitoring and assessment. Radiological Assistance Program teams assist state, local, and tribal officials in identifying the material and monitoring to determine if there is a release, as well as providing general support. Like private-sector shippers, DOE must provide emergency response information required on shipping papers, including a 24-hour emergency telephone number. Shippers have overall responsibility for providing adequate technical assistance for emergency response, should the carrier fail to do so.

Security requirements and shipping containers used for transporting radioactive and hazardous materials are commensurate with the hazard associated with those materials. Low-hazard shipments, such as most LLW and MLLW shipments, would not represent attractive targets for sabotage or terrorism because they have relatively low potential for producing human casualties. Relatively high-hazard shipments, such as TRU waste, also are not highly attractive targets because the accident-resistant packaging used to transport the higher-hazard materials provides a measure of protection against potential terrorist actions.

In summary, offsite shipments of LLW, MLLW, and TRU waste can be conducted safely. This is ensured by a number of means that emphasize preventing releases of radioactive and hazardous material in transit, including appropriate packaging, route selection, communications, vehicle safety, and driver training. In addition, in the unlikely event that an accidental release occurs, DOE would provide the necessary support to local first responders to effectively mitigate, clean up, monitor potential releases and provide any necessary medical treatment.

### **5.18.8 Area and Resource Management and Mitigation Plans**

DOE or its contractors have prepared, or are preparing, a number of area and resource management and mitigation plans. These plans have been completed, are in draft form, or are being revised. These plans include the following:

- *Hanford Cultural Resources Management Plan* (DOE-RL 2003a)
- *Hanford Site Biological Resources Management Plan* (DOE-RL 2001a)
- Hanford Bald Eagle Management Plan
- Noxious Weed Management Plan
- Chinook Salmon – Upper Columbia River Spring Run Hanford Management Plan
- Steelhead – Middle Columbia River Run Hanford Management Plan
- Steelhead Upper Columbia River Run Hanford Management Plan
- Aesthetic and Visual Resources Management Plan
- Facility and Infrastructure Assessment and Strategy
- Mineral Resources Management Plan (that is, soils, sand, gravel, and basalt)

- Hanford Site Watershed Management Plan
- *Hanford's Groundwater Management Plan: Accelerated Cleanup and Protection* (DOE-RL 2003d)
- *Sitewide Institutional Controls Plan for Hanford CERCLA Response Actions* (DOE-RL 2002b)
- *Hanford Site Biological Resources Mitigation Strategy* (DOE-RL 2003c).

All of the plans listed above would be expected to be available as DOE guidance by the time the activities described in this HSW EIS would be underway and for which special management or mitigation might be appropriate.

### Potential Mitigation Measures

- Continue implementing DOE's pollution prevention/waste minimization program.
- Perform cultural surveys prior to construction.
- Implement guidelines (such as the replacement of shrub-steppe community disturbed by construction or capping activities) consistent with the *Hanford Site Biological Resources Management Plan* and the *Hanford Site Biological Resources Mitigation Strategy*.
- Continue implementing As-Low-As-Reasonably-Achievable principles during operations and construction.
- Continue training and practices to prepare for possible emergencies and accidents.
- Perform large movements of construction and capping materials during low traffic times.
- Prepare and implement resource management plans and mitigation plans associated with the *Hanford Comprehensive Land Use Plan*.
- Construct new facilities and trenches in areas that have already been disturbed. This would minimize the chances for encountering items of cultural significance or disturbing items of cultural significance that have not been disturbed. It would also minimize the impacts to animals, plants, and ecosystems.
- Construct new trenches in uncontaminated areas within the Low Level Burial Grounds to minimize potential health impacts to workers.
- Construct final closure barriers that would allow the growth or re-growth of shrub-steppe habitat.
- Plan construction activities to avoid nesting seasons.
- Reuse soils removed during construction of disposal trenches for construction of final closure caps to the extent possible.
- Install and use rain curtains in operating trenches. This would prevent some of the rainwater and snow melt from coming into contact with waste already in place. This, in turn, would reduce the amount of waste that could leach into the rainwater, reduce the amount of contaminated rainwater (leachate) that would have to be treated, and reduce the amount of leachate that could possibly reach the vadose zone or groundwater.
- Use soil fixants to minimize dust generated during construction activities, waste disposal, and final closure activities.
- Treat and dispose of mixed-low level waste in storage as quickly as possible to minimize accidents and exposure to workers from aboveground storage.
- Certify and ship transuranic waste in storage as quickly as possible to minimize accidents and exposure to workers from aboveground storage.
- Keep areas around facilities and trenches clear of combustible material to limit impacts from wildfires.
- Keep trenches clear of deep-rooted plants and burrowing animals to minimize the potential for spreading contamination.
- Provide additional waste treatment prior to disposal.

### 5.18.9 Long-Term Stewardship and Post Closure

Cleanup plans and decisions strive to achieve an appropriate balance between contaminant reduction, use of engineered barriers to isolate residual contaminants and retard their migration, and reliance on institutional controls. Decisions are influenced by several factors:

- risks to members of the public, workers, and the environment
- legal and regulatory requirements
- technical and institutional capabilities and limitations
- current state of scientific knowledge
- values and preferences of interested and affected parties
- costs and related budgetary considerations
- impacts on, and activities at, other sites.

Reliance on institutional controls after contaminants have been reduced and engineered barriers have been put in place is referred to as long-term stewardship. Specific long-term stewardship activities depend on the specific hazards that remain and how those hazards are being controlled. Long-term stewardship activities are intended to continue isolating hazards from people and the environment.

DOE does not rely solely on long-term stewardship to protect people and the environment. As indicated in the DOE-sponsored report *Long-Term Institutional Management of U.S. Department of Energy Legacy Waste Sites* (National Research Council 2000), “contaminant reduction is preferred to contaminant isolation and the imposition of stewardship measures.” Contaminant reduction is a large part of the ongoing cleanup efforts at Hanford. The long-term stewardship plan for the Hanford Site was approved in August 2003 (DOE-RL 2003b).

#### Typical Long-Term Stewardship Activities

- monitoring to verify the integrity of barriers placed over disposal sites
- maintaining barriers to ensure their continued integrity
- monitoring groundwater and the vadose zone to determine whether systems to contain hazards are working
- monitoring for surface contamination
- monitoring animals, plants, and ecosystems
- performing groundwater pump-and-treatment operations
- installing and maintaining fences and other barriers
- posting warning signs
- establishing easements and deed restrictions
- establishing zoning and land-use restrictions
- maintaining records on cleanup activities, remaining hazards, and locations of the hazards
- maintaining necessary infrastructure (for example, utilities, roads, communication systems).

## 5.19 References

- 10 CFR 71. “Packaging and Transportation of Radioactive Material.” Code of Federal Regulations. Online at: [http://www.access.gpo.gov/nara/cfr/waisidx\\_01/10cfr71\\_01.html](http://www.access.gpo.gov/nara/cfr/waisidx_01/10cfr71_01.html)
- 10 CFR 835. “Occupational Radiation Protection.” Code of Federal Regulations. Online at: [http://www.access.gpo.gov/nara/cfr/waisidx\\_02/10cfr835\\_02.html](http://www.access.gpo.gov/nara/cfr/waisidx_02/10cfr835_02.html)
- 40 CFR 50. “National Primary and Secondary Ambient Air Quality Standards.” Code of Federal Regulations. Online at: [http://www.access.gpo.gov/nara/cfr/waisidx\\_01/40cfr50\\_01.html](http://www.access.gpo.gov/nara/cfr/waisidx_01/40cfr50_01.html)
- 40 CFR 61. “National Emission Standards for Hazardous Air Pollutants.” Code of Federal Regulations. Online at: [http://www.access.gpo.gov/nara/cfr/waisidx\\_02/40cfr61\\_02.html](http://www.access.gpo.gov/nara/cfr/waisidx_02/40cfr61_02.html)
- 40 CFR 141. “National Primary Drinking Water Regulations.” Code of Federal Regulations. Online at: [http://www.access.gpo.gov/nara/cfr/waisidx\\_01/40cfr141\\_01.html](http://www.access.gpo.gov/nara/cfr/waisidx_01/40cfr141_01.html)
- 40 CFR 143. “National Secondary Drinking Water Regulations.” Code of Federal Regulations. Online at: [http://www.access.gpo.gov/nara/cfr/waisidx\\_01/40cfr143\\_01.html](http://www.access.gpo.gov/nara/cfr/waisidx_01/40cfr143_01.html)
- 40 CFR 1500-1508. “Council on Environmental Quality Regulations for Implementing the Procedural Provisions of the National Environmental Policy Act.” Code of Federal Regulations. Online at: [http://www.access.gpo.gov/nara/cfr/waisidx\\_01/40cfrv28\\_01.html](http://www.access.gpo.gov/nara/cfr/waisidx_01/40cfrv28_01.html)
- 49 CFR 171-180. “Other Regulations Relating to Transportation.” Code of Federal Regulations. Online at: [http://www.access.gpo.gov/nara/cfr/waisidx\\_99/49cfrv2\\_99.html](http://www.access.gpo.gov/nara/cfr/waisidx_99/49cfrv2_99.html)
- 49 CFR 390-397. “Federal Motor Carrier Safety Regulations.” Code of Federal Regulations. Online at: [http://www.access.gpo.gov/nara/cfr/waisidx\\_01/49cfr390\\_01.html](http://www.access.gpo.gov/nara/cfr/waisidx_01/49cfr390_01.html)
- 59 FR 7629. “Executive Order 12898 of February 11, 1994: Federal Actions to Address Environmental Justice in Minority Populations and Low-Income Populations.” *Federal Register* (February 16, 1994). Online at: <http://www.gpoaccess.gov/fr/index.html>
- 62 FR 8693. “Record of Decision for the Tank Waste Remediation System, Hanford Site, Richland, WA.” *Federal Register* (February 26, 1997). Online at: <http://www.gpoaccess.gov/fr/index.html>
- 64 FR 61615. “Record of Decision: Hanford Comprehensive Land-Use Plan Environmental Impact Statement (HCP EIS).” *Federal Register* (November 12, 1999). Online at: <http://www.gpoaccess.gov/fr/index.html>
- 65 FR 24595. “Executive Order 13148 of April 21, 2000. Greening the Government Through Leadership in Environmental Management.” *Federal Register* (April 26, 2000). Online at: <http://www.gpoaccess.gov/fr/index.html>

65 FR 37253. "Establishment of the Hanford Reach National Monument." Proclamation 7319 of June 9, 2000 by the President of the United States of America. *Federal Register* (June 9, 2000). Online at: <http://www.gpoaccess.gov/fr/index.html>

65 FR 76708. "National Primary Drinking Water Regulations; Radionuclides; Final Rule." *Federal Register* (December 7, 2000). Online at: <http://frwebgate.access.gpo.gov>

42 USC 4321 et seq. National Environmental Policy Act (NEPA) of 1969, as amended. Online at: <http://www4.law.cornell.edu>

42 USC 6901 et seq. Resource Conservation and Recovery Act (RCRA) of 1976. Online at: <http://www4.law.cornell.edu>

42 USC 7401 et seq. Clean Air Act. Online at: <http://www4.law.cornell.edu>

42 USC 9601 et seq. Comprehensive Environmental Response, Compensation, and Liability Act (CERCLA) of 1980. Online at: <http://www4.law.cornell.edu>

Barcot, R. A. 2002. *Solid Waste Integrated Forecast Technical (SWIFT) Report*. HNF-EP-0918, Rev. 9, Fluor Hanford, Inc., Richland, Washington.

Becker, J. M. and M. R. Sackschewsky. 2001. *Addendum to the 200 West Area Dust Mitigation Strategies: Treatment of the Dust Source Area*. PNNL-13884, Pacific Northwest National Laboratory, Richland, Washington.

Belnap, J. 1993. "Recovery Rates of Cryptobiotic Crusts: Inoculant Use and Assessment Methods." *Great Basin Naturalist* 53(1):89-95.

Belnap, J. and K. T. Harper. 1995. "Influence of Cryptobiotic Crusts on Elemental Content of Tissue of Two Desert Seed Plants." *Arid Soil Research and Rehabilitation* 9:107-115.

Belnap, J., J. H. Kaltenecker, R. Rosentreter, J. Williams, S. Leonard, and D. Eldrige. 2001. *Biological Soil Crusts: Ecology and Management*. Technical Reference 1730-1732. Bureau of Land Management, Denver, Colorado. Online at: <http://www.blm.gov/nstc/library/pdf/CrustManual.pdf>

Bergeron M. P. and S. K. Wurstner. 2000. *Groundwater Flow and Transport Calculations Supporting the Immobilized Low-Activity Waste Disposal Facility Performance Assessment*. PNNL-13400, Pacific Northwest National Laboratory, Richland, Washington.

Biwier, B. M. and J. P. Butler. 1999. "Vehicle Emission Unit Risk Factors for Transportation Risk Assessments." *Risk Analysis* 19(6):1157-1171.

Bryce, R. W., C. T. Kincaid, P. W. Eslinger, and L. F. Morasch (eds.). 2002. *An Initial Assessment of Hanford Impact Performed with the System Assessment Capability*. PNNL-14027, Pacific Northwest National Laboratory, Richland, Washington. Online at: [http://www.pnl.gov/main/publications/external/technical\\_reports/PNNL-14027/PNNL-14027.pdf](http://www.pnl.gov/main/publications/external/technical_reports/PNNL-14027/PNNL-14027.pdf)

Burbank, D. A. 2001. *Conceptual Design Report for Immobilized Low-Activity Waste Disposal Facility, Project W-520*. RPP-7908, Rev. 0, CH2M Hill Hanford Group, Inc., Richland, Washington.

Bushore, R. P. 1999. *Safety Assessment for Project W-259: T Plant Complex Secondary Containment and Leak Detection Upgrades*. HNF-2896, Rev. 0, Fluor Hanford, Richland, Washington.

Bushore, R. P. 2001. *Interim Safety Basis for Solid Waste Facilities (T Plant)*. HNF-SD-WM-ISM-006, Rev. 2, Fluor Hanford, Inc., Richland, Washington.

CDC. 2003. *Deaths, Age-adjusted Death Rates, and Comparisons by State for Selected Leading Causes of Death*. U.S. Department of Health and Human Services, Centers for Disease Control and Prevention, National Center for Health Statistics, Hyattsville, Maryland. Online at: <http://www.cdc.gov/nchs/releases/03facts/mortalitytables.htm>

Census. 2000a. American FactFinder. U.S. Bureau of the Census, U.S. Department of Commerce, Washington, D.C. Online at: <http://quickfacts.census.gov/qfd/states/53/53005.html>

Census. 2000b. American FactFinder. U.S. Bureau of the Census, U.S. Department of Commerce, Washington, D.C. Online at: <http://quickfacts.census.gov/qfd/states/53/53021.html>

CEQ. 1997a. *Considering Cumulative Effects Under the National Environmental Policy Act*. Council on Environmental Quality, Executive Office of the President, Washington, D.C. (January 1997). Online at: <http://ceq.eh.doe.gov/nepa/regs/ej/justice.pdf>

CEQ. 1997b. *Environmental Justice. Guidance Under the National Environmental Policy Act*. Council on Environmental Quality, Executive Office of the President, Washington, D.C. Online at: <http://ceq.eh.doe.gov/nepa/regs/ej/justice.pdf>

Chatters, J. C. and N. A. Cadoret. 1990. *Archeological Survey of the 200-East and 200-West Areas, Hanford Site, Richland, Washington*. PNL-7264, Pacific Northwest Laboratory, Richland, Washington.

Cothorn, C. R. and W. L. Lappenbusch. 1983. "Occurrence of Uranium in Drinking Water in the U.S." *Health Physics*, 45(1):89-99.

DOE. 1993. *Radiation Protection of the Public and the Environment*. DOE Order 5400.5, U.S. Department of Energy, Washington, D.C. Online at: <http://www.directives.doe.gov>

DOE. 1995. *Department of Energy Programmatic Spent Nuclear Fuel Management and Idaho National Engineering Laboratory Environmental Restoration and Waste Management Programs Final Environmental Impact Statement*. DOE/EIS-0203-F, U.S. Department of Energy, Office of Environmental Management, Idaho Operations Office, Idaho Falls, Idaho.

DOE. 1996a. *Management of Spent Nuclear Fuel from the K Basins at the Hanford Site, Richland, Washington*. DOE/EIS-0245, U.S. Department of Energy, Richland, Washington.

DOE. 1996b. *Plutonium Finishing Plant Stabilization Final Environmental Impact Statement*. DOE/EIS-0244-F, U.S. Department of Energy, Richland Operations Office, Richland, Washington.

DOE. 1997a. *Final Waste Management Programmatic Environmental Impact Statement for Managing Treatment, Storage, and Disposal of Radioactive and Hazardous Waste*. DOE/EIS-0200-F, Vol. 1-5, U.S. Department of Energy, Washington, D.C.

DOE. 1997b. *Waste Isolation Pilot Plant Disposal Phase Final Supplemental Environmental Impact Statement*. DOE/EIS-0026-S-2, U.S. Department of Energy, Carlsbad Area Office, Carlsbad, New Mexico.

DOE. 1999. *Final Hanford Comprehensive Land-Use Plan Environmental Impact Statement*. DOE/EIS-0222-F, U.S. Department of Energy, Washington, D.C. Online at: <http://www.hanford.gov/eis/hraeis/maintoc.htm>

DOE. 2001a. *Radioactive Waste Management Manual*. DOE Manual 435.1-1, U.S. Department of Energy, Washington, D.C. Online at: <http://www.directives.doe.gov>

DOE. 2001b. *Radioactive Waste Management*. DOE Order 435.1, Change 1, U.S. Department of Energy, Washington, D.C. Online at: <http://www.directives.doe.gov>

DOE. 2002a. *Final Environmental Impact Statement for a Geologic Repository for the Disposal of Spent Nuclear Fuel and High-Level Radioactive Waste at Yucca Mountain, Nye County, Nevada*. DOE/EIS-0250, Office of Civilian Radioactive Waste Management, U.S. Department of Energy, Washington, D.C.

DOE. 2002b. *Radioactive Material Transportation Practices Manual for Use with DOE O 460.2*. DOE Manual 460.2-1, U.S. Department of Energy, Washington, D.C. Online at: <http://www.directives.doe.gov/pdfs/doe/doetext/neword/460/m4602-1.pdf>

DOE. 2002c. *Transuranic Waste Performance Management Plan*. U.S. Department of Energy, Carlsbad Field Office, Carlsbad, New Mexico. Online at: <http://www.wipp.carlsbad.nm.us/suyw/july2002/FTWPMP.pdf>



DOE. 2003. *Revised Draft Hanford Site Solid (Radioactive and Hazardous) Waste Program Environmental Impact Statement, Richland Washington*. DOE/EIS-0286D2, U.S. Department of Energy, Richland Operations Office, Richland, Washington. Online at: <http://www.hanford.gov/eis/eis-0286D2>

DOE-RL. 1995. *Ecological Compliance Assessment Management Plan*. DOE/RL-95-11, Rev. 1, U.S. Department of Energy, Richland Operations Office, Richland, Washington.

DOE-RL. 1998. *Control of the Spread of Radioactive Contamination Due to Biological Transport on the Hanford Site*. DOE/RL-98-77, U.S. Department of Energy, Richland Operations Office, Richland, Washington.

DOE-RL. 1999. *Hanford Emergency Management Plan*. DOE/RL-94-02, Rev.2, U.S. Department of Energy, Richland Operations Office, Richland, Washington.

DOE-RL. 2000a. *Hanford, Diversification, and the Tri-Cities Economy, FY 1999*. DOE/RL-2000-32, U.S. Department of Energy, Richland Operations Office, Richland, Washington.

DOE-RL. 2000b. *Threatened and Endangered Species Management Plan: Salmon and Steelhead*. DOE/RL-2000-27, Rev. 0, U.S. Department of Energy, Richland, Washington.

DOE-RL. 2000c. *Type B Accident Investigation – U.S. Department of Energy Response to the 24 Command Wildland Fire on the Hanford Site – June 27-July 1, 2000*. DOE/RL-2000-63, U.S. Department of Energy, Richland Operations Office, Richland, Washington. Online at: <http://www.hanford.gov/docs/rl-2000-63/index.html>

DOE-RL. 2001a. *Hanford Site Biological Resources Management Plan*. DOE/RL 96-32, Rev. 0, U.S. Department of Energy, Richland Operations Office, Richland, Washington.

DOE-RL. 2001b. *Hanford Site Waste Minimization and Pollution Prevention Awareness Program Plan*. DOE/RL-91-31, Rev. 5, U.S. Department of Energy, Richland Operations Office, Richland, Washington.

DOE-RL. 2002a. *History of the Plutonium Production Facilities at the Hanford Site Historic District, 1943-1990*. DOE/RL-97-1047, U.S. Department of Energy, Richland Operations Office, Richland, Washington. Online at: <http://www.hanford.gov/docs/rl-97-1047/index.pdf>

DOE-RL. 2002b. *Sitewide Institutional Controls Plan for Hanford CERCLA Response Actions*. DOE/RL-2001-41, Rev. 0, U.S. Department of Energy, Richland Operations Office, Richland, Washington. Online at: <http://www.hanford.gov/tpa/announce/DOE-RL-2001-41.pdf>

DOE-RL. 2003a. *Hanford Cultural Resources Management Plan*. DOE/RL-98-10, Rev. 0, U.S. Department of Energy, Richland Operations Office, Richland, Washington.

DOE-RL. 2003b. *Hanford Long-Term Stewardship Program and Transition: Preparing for Environmental Management Cleanup Completion*. DOE/RL-2003-39, Rev. 0, U.S. Department of Energy, Richland, Washington.

DOE-RL. 2003c. *Hanford Site Biological Resources Mitigation Strategy*. DOE/RL-96-88, Rev. 0, U.S. Department of Energy, Richland Operations Office, Richland, Washington. Online at: <http://www.pnl.gov/ecology/ecosystem/Docs/BRMiS.pdf>

DOE-RL. 2003d. *Hanford's Groundwater Management Plan: Accelerated Cleanup and Protection*. DOE/RL-2002-68, U.S. Department of Energy, Richland Operations Office, Richland, Washington.

DOE and Ecology. 1996. *Tank Waste Remediation System, Hanford Site, Richland, Washington, Final Environmental Impact Statement*. DOE/EIS-0189, U.S. Department of Energy Richland Operations Office, Richland, Washington and Washington State Department of Ecology, Olympia, Washington.

DOE, EPA, and Ecology. 1998. "Maintenance of the Waste Information Data System (WIDS)," In Tri-Party Agreement Handbook Management Procedures. RL-TPA-90-0001, Guideline TPA-MP-14, U.S. Department of Energy, Washington, D.C., Environmental Protection Agency, Washington, D.C. and State of Washington Department of Ecology, Olympia, Washington.

DOT. 2002. *State Traffic Safety Information for Year 2001*. U.S. Department of Transportation, National Highway Traffic Safety Administration, Washington, D.C. Online at: <http://www.nhtsa.dot.gov/STSI/index.cfm?Year=2001>

Ebasco Services, Inc. 1993. *Analysis of Carbon Tetrachloride Evaporative Losses and Residual Inventory Beneath 200 West Area at the Hanford Site*. WHC-SD-EN-TI-101, Rev. 0, Prepared by Ebasco Services, Inc. for Westinghouse Hanford Company, Richland, Washington.

Eckerman, K. F., R. W. Leggett, C. B. Nelson, J. S. Puskin, and A. C. B. Richardson. 1999. *Cancer Risk Coefficients for Environmental Exposure to Radionuclides*. Federal Guidance Report No. 13. EPA 402-R-99-001. Office of Radiation and Indoor Air, U.S. Environmental Protection Agency, Washington, D.C. Online at: <http://riskassessment.ornl.gov/keydocs/fgr13.pdf>

EPA. 1991. *Integrated Risk Information System (IRIS)*. National Center for Environmental Assessment, Cincinnati, Ohio. Online at: <http://toxnet.nlm.nih.gov/cgi-bin/sis/htmlgen?IRIS.htm>

EPA. 1995. *User's Guide for the Industrial Source Complex (ICS3) Dispersion Models. Volumes 1 & 2. User Instructions*. EPA-454/B-95-003a, U.S. Environmental Protection Agency, Research Triangle Park, North Carolina.

EPA. 2000a. *Drinking Water Standards and Health Advisories*. EPA 822-B-00-001, Office of Water, Environmental Protection Agency, Washington, D.C.

EPA. 2000b. *Heavy-Duty Engine and Vehicle Standards and Highway Diesel Fuel Sulfur Control Requirements*. EPA 420-F-00-057, U.S. Environmental Protection Agency, Research Triangle Park, North Carolina. Online at: <http://www.epa.gov/otaq/regs/hd2007/frm/f00057.pdf>

ERDA. 1975. *Final Environmental Statement, Waste Management Operations, Hanford Reservation, Richland, Washington*. ERDA-1538, U.S. Energy Research and Development Administration, Washington, D.C.

Farris, W. T., B. A. Napier, J. C. Simpson, S. F. Snyder, and D. B. Shipler. 1994. *Columbia River Pathway Dosimetry Report, 1944-1992*. PNWD-2227-HEDR, Battelle, Pacific Northwest Laboratory, Richland, Washington.

FH. 2004. *Hanford Site Solid Waste Management Environmental Impact Statement Technical Information Document*. HNF-4755, Rev. 2, Fluor Hanford, Inc., Richland, Washington.

FTA. 1995. *Transit Noise and Vibration Impact Assessment*. DOT-T-95-16, U.S. Department of Transportation, Federal Transit Authority, Washington, D.C. Online at: [http://www.hmmh.com/rail\\_manuals01fta.html](http://www.hmmh.com/rail_manuals01fta.html)

Gilmore, J. S. and M. K. Duff. 1975. *Boom Town Growth Management: A Case Study of Rock Springs-Green River, Wyoming*. Westview Press, Boulder, Colorado.

Green, J. R., B. D. Flanagan, and H. W. Harris. 1996. *Hanford Site Truck Accident Rate, 1990-1995*. WHC-SD-TP-RPT-021, Rev. 0, Westinghouse Hanford Co., Richland, Washington.

Hakonsen, T. E. 1986. *Evaluation of Geologic Materials to Limit Biological Intrusion into Low-Level Radioactive Waste Disposal Sites*. LA-10286-MS LA-10286-MS E1.99:DE86 007590, Los Alamos National Laboratory, Los Alamos, New Mexico.

Harris, S. G. and B. L. Harper. 1997. "A Native American Exposure Scenario." *Risk Analysis* 17(6):789-795.

Hartman, M. J., L. F. Morasch, and W. D. Webber, eds. 2002. *Hanford Site Groundwater Monitoring for Fiscal Year 2001*. PNNL-13788, Pacific Northwest National Laboratory, Richland, Washington. Online at: <http://groundwater.pnl.gov/reports/gwrep01/start.htm>

Johansen, J. R., J. Ashley, and W. R. Rayburn. 1993. "Effects of Rangefire on Soil Algal Crusts in Semiarid Shrub-Steppe of the Lower Columbia Basin and their Subsequent Recovery." *Great Basin Naturalist* 53(1):73-88.

Johnson, A. R., B. M. Markes, J. W. Schmidt, A. N. Shah, S. G. Weiss, and K. J. Wilson. 1994. *Historical Records of Radioactive Contamination in Biota at the 200 Areas of the Hanford Site*. WHC-MR-0418, Rev. 0, Westinghouse Hanford Company, Richland, Washington.

Johnson, P. E. and R. D. Michelhaugh. 2000. *Transportation Routing Analysis Geographic Information System (WebTRAGIS) User's Manual*. ORNL/TM-2000/86, Oak Ridge National Laboratory, Oak Ridge, Tennessee. Online at: <http://www.ornl.gov/~webworks/cpr/v823/rpt/106749.pdf>

Jones & Stokes. 2002. *Draft Farad Diversion Dan Replacement Project Environmental Impact Report March*. J&S 00475, Prepared for State Water Resources Control Board by Jones & Stokes, Sacramento, California.

Jordan, R. E. and J. R. Payne. 1980. *Fate and Weathering of Petroleum Spills in the Marine Environment: A Literature Review and Synopsis*. Ann Arbor Science Publishers, Inc., Ann Arbor, Michigan.

Junkins, R. L., E. C. Watson, I. C. Nelson, and R. C. Henle. 1960. *Evaluation of Radiological Conditions in the Vicinity of Hanford for 1959*. HW-64371, Hanford Atomic Products Operation, Richland, Washington. Online at: <http://www2.hanford.gov/DDRS/common/findpage.cfm?AKey=D8457179>

Kaplan, D. I., R. J. Serne, and M. G. Piepho. 1995. *Geochemical Factors Affecting Radionuclide Transport Through Near and Far Field at a Low-Level Waste Disposal Site*. PNL-10379, Pacific Northwest Laboratory, Richland, Washington. Online at: <http://www.osti.gov/servlets/purl/28418-huG5C8/webviewable>

Kincaid, C. T., M. P. Bergeron, C. R. Cole, M. D. Freshley, N. L. Hassig, V. G. Johnson, D. I. Kaplan, R. J. Serne, G. P. Streile, D. L. Strenge, P. D. Thorne, L. W. Vail, G. A. Whyatt, and S. K. Wurstner. 1998. *Composite Analysis for Low-Level Waste Disposal in the 200 Areas Plateau of the Hanford Site*. PNNL-11800, Pacific Northwest National Laboratory, Richland, Washington.

Kincaid, C. T., P. W. Eslinger, W. E. Nichols, A. L. Bunn, R. W. Bryce, T. B. Miley, M. C. Richmond, S. F. Snyder, and R. L. Aaberg. 2000. *Groundwater/Vadoes Zone Integration Project System Assessment Capability (Revision 0) Assessment Description, Requirements, Software Design, and Test Plan*. BHI-01365, Draft A, Bechtel Hanford, Inc., Richland, Washington.

Krupka, K. M. and R. J. Serne. 1996. *Performance Assessment of Low-Level Radioactive Waste Disposal Facilities: Effects on Radionuclide Concentrations by Cement/Ground-Water Interactions*. NUREG/CR-6377, U.S. Nuclear Regulatory Commission, Washington, D.C.

Mann, F. M., K. C. Burgard, W. R. Root, R. J. Puigh, S. H. Finfrock, R. Khaleel, D. H. Bacon, E. J. Freeman, B. P. McGrail, S. K. Wurstner, and P. E. LaMont. 2001. *Hanford Immobilized Low-Activity Waste Performance Assessment: 2001 Version*. DOE/ORP-2000-24, Rev. 0, U.S. Department of Energy, Office of River Protection, Richland, Washington.

Markes, B. M. and S. M. McKinney. 2001. *Quarterly Environmental Radiological Survey Summary*. HNF-SP-0665-38. Duratek Federal Services, Richland, Washington.

Minnesota IMPLAN Group, Inc. 1997. *1993 Micro IMPLAN User's Guide*. Minnesota IMPLAN Group, St. Paul, Minnesota.

Montgomery, J. H. 1996. *Groundwater Chemicals - Desk Reference, 2nd Edition*. CRC Press, Inc., Boca Raton, Florida.

MRSC. 2001. *2000 Municipal Population by County*. Municipal Research & Services Center of Washington, Seattle, Washington. Online at:  
<http://www.mrsc.org/subjects/governance/countpop.aspx?r=1>

National Research Council. 2000. *Long-Term Institutional Management of U.S. Department of Energy Legacy Waste Sites*. Prepared by Committee on the Remediation of Buried and Tank Wastes, Board on Radioactive Waste Management, Commission on Geosciences, Environment and Resources, National Research Council, National Academy Press, Washington, D.C. Online at:  
<http://www.nap.edu/books/0309071860/html>

Navy. 1984. *Disposal of Decommissioned Defueled Naval Submarine Reactor Plants Environmental Impact Statement*. U.S. Department of the Navy, Washington, D.C.

Navy. 1996. *Final Environmental Impact Statement on the Disposal of Decommissioned, Defueled Cruiser, Ohio Class, and Los Angeles Class Naval Reactor Plants*. DOE/EIS-0259, U.S. Department of the Navy, Washington, D.C.

NCRP. 1987. *Exposure of the Population in the United States and Canada from Natural Background Radiation*. NCRP Report No. 94, NCRP Publications, National Council on Radiation Protection and Measurements, Bethesda, Maryland.

NCRP. 1993. *Limitation of Exposure to Ionizing Radiation: recommendations of the National Council on Radiation Protection and Measurements*. NCRP Report No. 116, National Council on Radiation Protection and Measurements, Bethesda, Maryland.

NCRP. 2002. *Managing Potentially Radioactive Scrap Metal: Recommendations of the National Council on Radiation Protection and Measurements*. NCRP Report No. 141, National Council on Radiation Protection and Measurements, Bethesda, Maryland.

Neitzel, D. A. (ed.). 2001. *Hanford Site National Environmental Policy Act (NEPA) Characterization*. PNNL-6415, Rev. 13, Pacific Northwest National Laboratory, Richland, Washington. Online at:  
[http://www.pnl.gov/main/publications/external/technical\\_reports/pnnl-6415rev13.pdf](http://www.pnl.gov/main/publications/external/technical_reports/pnnl-6415rev13.pdf)

Neuhauser, K. S., F. L. Kanipe, and R. F. Weiner. 2003. *RADTRAN 5 User Guide*. SAND2003-2354, Sandia National Laboratories, Albuquerque, New Mexico. Online at:  
[http://infoserve.sandia.gov/sand\\_doc/2003/032354.pdf](http://infoserve.sandia.gov/sand_doc/2003/032354.pdf)

Perkins, C. J., B. M. Markes, S. M. McKinney, R. M. Mitchell, and R. C. Roos. 2001. *Hanford Site Near-Facility Environmental Monitoring Data Report for Calendar Year 2000*. PNNL-13487 Appendix 2, Pacific Northwest National Laboratory, Richland, Washington.

Poston, T. M., R. W. Hanf, R. L. Dirkes, and L. F. Morasch. 2001. *Hanford Site Environmental Report for Calendar Year 2000*. PNNL-13487, Pacific Northwest National Laboratory, Richland, Washington. Online at: <http://hanford.gov/docs/annualrp00>

Poston, T. M., R. W. Hanf, R. L. Dirkes, and L. F. Morasch (eds.). 2002. *Hanford Site Environmental Report for Calendar Year 2001*. PNNL-13910, Pacific Northwest National Laboratory, Richland, Washington. Online at: <http://hanford-site.pnl.gov/envreport/2001/index.htm>

PSU. 2002. *2002 Oregon Population Report, Population Growth in Oregon: 2000 to 2002*. Population Research Center, Portland State University, Portland, Oregon. Online at: <http://www.upa.pdx.edu/CPRC/publications/annualorpopulation/ORpopreport02.pdf>

Sackschewsky, M. R. and J. M. Becker. 2001. *200 West Area Dust Mitigation Strategies*. PNNL-13883, Pacific Northwest National Laboratory, Richland, Washington.

Sackschewsky, M. R. and J. L. Downs. 2001. *Vascular Plants of the Hanford Site*. PNNL-13688, Pacific Northwest National Laboratory, Richland, Washington.

Saricks, C. L. and M. M. Tompkins. 1999. *State-Level Accident Rates of Surface Freight Transportation: A Reexamination*. ANL/ESD/TM-150, Argonne National Laboratory, Argonne, Illinois. Online at: <http://www.ipd.anl.gov/anlpubs/1999/05/32608.pdf>

Serne, R. J., D. Rai, P. F. Martin, A. R. Felmy, L. Rao, and S. Ueta. 1996. "Leachability of Nd, U, Th, and Sr From Cements in a CO<sub>2</sub> Free Atmosphere," in *Scientific Basis for Nuclear Waste Management XIX*, W. M. Murphy and D. A. Knecht. (eds.). Materials Research Society, Pittsburgh, Pennsylvania. Vol. 412:459-467.

Shields, L. M., C. Mitchell, and F. Drouet. 1957. "Alga- and Lichen-Stabilized Surface Crusts as Soil Nitrogen Sources." *American Journal of Botany* 44:489-498.

Tomaszewski, T. A. 2001. *WRAP Final Safety Analysis Report*. HNF-SD-W026-SAR-002, Rev 2, Fluor Hanford, Inc., Richland, Washington.

Treaty with the Yakama. 1855. June 9, 1855, 12 Stat. 951.

Truex, M. J., C. J. Murray, C. R. Cole, R. J. Cameron, M. D. Johnson, R. S. Skeen, and C. D. Johnson. 2001. *Assessment of Carbon Tetrachloride Groundwater Transport in Support of the Hanford Carbon Tetrachloride Innovative Technology Demonstration Program*. PNNL-13560, Pacific Northwest National Laboratory, Richland, Washington. Online at: [http://www.pnl.gov/main/publications/external/technical\\_reports/PNNL-13560.pdf](http://www.pnl.gov/main/publications/external/technical_reports/PNNL-13560.pdf)

Vail, T. S. 2001a. *Central Waste Complex Interim Safety Basis*. HNF-SD-WM-ISB-007, Rev. 1-E, Fluor Hanford, Inc., Richland, Washington.

Vail, T. S. 2001b. *Solid Waste Burial Grounds Interim Safety Analysis*. HNF-SD-WM-SARR-028, Rev. 3-C, Fluor Hanford, Inc., Richland, Washington.

Vail, T. S. 2001c. *Solid Waste Burial Grounds Interim Safety Basis*. HNF-SD-WM-ISM-002, Rev. 3-B, Fluor Hanford, Inc., Richland, Washington.

Vogel, T. M., C. S. Criddle, and P. L. McCarty. 1987. "Transformations of Halogenated Aliphatic Compounds." *Environmental Science and Technology*, 21: 722-736.

WAC 173-60. "Maximum Environmental Noise Levels." Washington Administrative Code. Olympia, Washington. Online at:

<http://www.leg.wa.gov/wac/index.cfm?fuseaction=chapterdigest&chapter=173-60>

WAC 246-247. "Radiation Protection – Air Emissions." Washington Administrative Code, Olympia, Washington. Online at:

<http://www.leg.wa.gov/wac/index.cfm?fuseaction=chapterdigest&chapter=246-247>

WAC 246-290. "Public Water Supplies." Washington Administrative Code, Olympia, Washington. Online at: <http://www.leg.wa.gov/wac/index.cfm?fuseaction=chapterdigest&chapter=246-290>

WHC. 1991. *Hazard Classification and Preliminary Safety Evaluation for Waste Receiving and Processing (WRAP) Module 2 Project W100*. WHC-SD-W100-PSE-001, Rev. 0, October 1991, Westinghouse Hanford Company, Richland, Washington.

Wood, M. I., R. Khaleel, P. D. Rittmann, A. H. Lu, S. H. Finfrock, R. J. Serne, K. J. Cantrell, and T. H. DeLorenzo. 1995. *Performance Assessment for the Disposal of Low-Level Waste in the 200 West Area Burial Grounds*. WHC-EP-0645, Westinghouse Hanford Company, Richland, Washington.

Wood, M. I., R. Khaleel, P. D. Rittmann, S. H. Finfrock, T. H. DeLorenzo, and D. Y. Garbrick. 1996. *Performance Assessment for the Disposal of Low-Level Waste in the 200-East Area Burial Grounds*. WHC-SD-WM-TI-730, Rev. 0, Westinghouse Hanford Company, Richland, Washington.

## 6.0 Regulatory Framework

This section describes the regulatory framework affecting the alternatives, including the permit requirements associated with the alternatives. The U.S. Department of Energy (DOE) has procedures implementing the National Environmental Policy Act (NEPA) (42 USC 4321 et seq.) in the Code of Federal Regulations (CFR) (10 CFR 1021). Section 1021.103 of the procedures adopts the Council on Environmental Quality (CEQ) regulations at 40 CFR 1500–1508 for implementing NEPA. This Hanford Site Solid (Radioactive and Hazardous) Waste Program Environmental Impact Statement (HSW EIS) was prepared in accordance with the DOE and CEQ NEPA implementing procedures.

### 6.1 Potentially Applicable Statutes

Significant statutes with potential applicability to the subject matter of the HSW EIS are listed below. Federal statutes are discussed in Section 6.1.1. Washington State Statutes are discussed in Section 6.1.2.

#### 6.1.1 Federal Statutes

- **American Antiquities Preservation Act (16 USC 431 et seq.)**  
The American Antiquities Preservation Act protects historic and prehistoric ruins, monuments, and antiquities, including paleontological resources, on federally controlled lands.
- **American Indian Religious Freedom Act (42 USC 1996)**  
The American Indian Religious Freedom Act states that it will be the policy of the United States to protect and preserve for American Indians their inherent right of freedom to believe, express, and exercise the traditional religions of the American Indian, Eskimo, Aleut, and Native Hawaiians, including, but not limited to, access to sites, use and possession of sacred objects, and the freedom to worship through ceremonials and traditional rites.
- **Archaeological and Historic Preservation Act (16 USC 469 et seq.)**  
The purpose of the Archaeological and Historic Preservation Act is to provide for the preservation of historical and archeological data (including relics and specimens) that might otherwise be irreparably lost or destroyed as the result of federal actions.
- **Archaeological Resources Protection Act (16 USC 470aa et seq.)**  
The Archaeological Resources Protection Act requires a permit for any excavation or removal of archaeological resources from federal or Indian lands. Excavations must be undertaken for the purpose of furthering archaeological knowledge in the public interest, and resources removed are to remain the property of the United States. Consent must be obtained from the Indian Tribe or the federal agency having authority over the land on which a resource is located before issuance of a permit. The permit must contain terms and conditions requested by the Tribe or federal agency.



- **Atomic Energy Act (42 USC 2011 et seq.)**

The Atomic Energy Act (AEA) provides the fundamental jurisdictional authority to DOE and the Nuclear Regulatory Commission (NRC) over governmental and commercial use of nuclear materials. The AEA authorizes DOE to establish standards to protect health or minimize dangers to life or property with respect to activities under DOE jurisdiction. The DOE has used a series of departmental orders and regulations to establish an extensive system of standards and requirements to ensure safe operation of DOE facilities. The AEA gives the Environmental Protection Agency (EPA) the authority to develop generally applicable standards for protection of the general environment from radioactive materials. The EPA has promulgated several regulations under this authority.

- **Bald and Golden Eagle Protection Act (16 USC 668 et seq.)**

The Bald and Golden Eagle Protection Act makes it unlawful to take, pursue, molest, or disturb bald and golden eagles, their nests, or their eggs anywhere in the United States. A permit must be obtained from the U.S. Department of the Interior to relocate a nest that interferes with resource development or recovery operations.

- **Clean Air Act (42 USC 7401 et seq.)**

The Clean Air Act (CAA) is intended to “protect and enhance the quality of the Nation’s air resources so as to promote the public health and welfare and the productive capacity of its population.”

Section 118 of the CAA requires each federal agency, with jurisdiction over properties or facilities engaged in any activity that might result in the discharge of air pollutants, to comply with all federal, state, interstate, and local requirements with regard to the control and abatement of air pollution.

Section 109 of the CAA directs EPA to set national ambient air quality standards (NAAQS) for criteria pollutants. EPA has identified and set NAAQS for the following criteria pollutants: particulate matter, sulfur dioxide, carbon monoxide, ozone, nitrogen dioxide, and lead. The NAAQS are set out in 40 CFR 50. Section 111 of the CAA requires establishment of national performance standards for new or modified stationary sources of atmospheric pollutants. Specific emission increases must be evaluated in order to prevent significant deterioration of air quality. Emissions of air pollutants are regulated by the EPA in 40 CFR 50-99. Emissions of radionuclides and hazardous air pollutants are regulated under the National Emissions Standards for Hazardous Air Pollutants Program (40 CFR 61 and 40 CFR 63).

- **Clean Water Act (CWA) (33 USC 1251 et seq.) (the CWA is also known as the Federal Water Pollution Control Act)**

The Clean Water Act (CWA) was enacted to “restore and maintain the chemical, physical, and biological integrity of the Nation’s water.” The CWA prohibits “discharge of toxic pollutants in toxic amounts” to navigable waters of the United States. Section 313 of the CWA requires all branches of the federal government with jurisdiction over properties or facilities engaged in any activity that might result in a discharge or runoff of pollutants to surface waters, to comply with federal, state, interstate, and local requirements. In addition to setting water quality standards for waterways, the CWA provides guidelines and limitations for effluent discharges from point sources and gives authority for the EPA to implement the National Pollutant Discharge Elimination System (NPDES) Permitting Program. Stormwater discharges are regulated under the NPDES Program.

- **Comprehensive Environmental Response, Compensation, and Liability Act as amended by the Superfund Amendments and Reauthorization Act (42 USC 9601 et seq.)**

The Comprehensive Environmental Response, Compensation, and Liability Act (CERCLA) provides a statutory framework for the remediation of waste sites containing hazardous substances and, as amended by the Superfund Amendments and Reauthorization Act, an emergency response program in the event a release (or threat of a release) of a hazardous substance to the environment occurs. Using a hazard ranking system, federal and private contaminated sites are ranked and may be included on the National Priorities List. CERCLA requires federal facilities with contaminated sites to undertake investigations, remediation, and natural resource restoration, as necessary.

- **Emergency Planning and Community Right-to-Know Act (42 USC 11001 et seq.)**

Federal facilities are required under Subtitle A of the Emergency Planning and Community Right-to-Know Act to provide information regarding the inventories of chemicals used or stored at a site and releases from that site to EPA and the state and local emergency response offices. The goal of providing this information is to ensure that emergency plans are sufficient to respond to unplanned releases of hazardous substances. The required information includes inventories of specific chemicals used or stored and descriptions of releases that occur from sites.

- **Endangered Species Act (16 USC 1531 et seq.)**

The Endangered Species Act is intended to prevent further decline of endangered and threatened species and to restore those species and their habitats. Section 7 of the act requires federal agencies to consult with the U.S. Fish and Wildlife Service (FWS) and the National Marine Fisheries Service to ensure that any action carried out by the agency is not likely to jeopardize the continued existence of any endangered or threatened species or result in the destruction or adverse modification of any critical habitat for such species.

- **Fish and Wildlife Coordination Act (16 USC 661 et seq.)**

The Fish and Wildlife Coordination Act promotes more effectual planning and cooperation between federal, state, public, and private agencies for the conservation and rehabilitation of the nation's fish and wildlife. The act requires federal agencies to consult with the FWS whenever they plan to conduct, license, or permit an activity involving the impoundment, diversion, deepening, control, or modification of a stream or body of water. The act also requires consultation with the head of the state agency that administers wildlife resources in the affected state. The purpose of this process is to promote conservation of wildlife resources by preventing loss of and damage to such resources and to provide for the development and improvement of wildlife resources in connection with the agency action.

- **Hazardous Materials Transportation Act (49 USC 5101 et seq.)**

The Hazardous Materials Transportation Act authorizes the U.S. Department of Transportation to regulate the transportation of hazardous materials by rail, aircraft, vessel, and public highway. Hazardous materials are defined as those chemicals that the Department of Transportation has determined pose unreasonable risks to health, safety, and property during transport activities. The statute and its implementing regulations address issues such as shipping papers to identify and track

hazardous materials, packaging and container design, marking, labeling, and performance standards, and employee and public training programs. The regulations also contain specific requirements relating to the type of shipment being used (i.e., rail, aircraft, vessel, and public highway).

- **Migratory Bird Treaty Act (16 USC 703 et seq.)**

The Migratory Bird Treaty Act is intended to protect birds that have common migration patterns between the United States and Canada, Mexico, Japan, and Russia. The act regulates the harvest of migratory birds by specifying factors such as the mode of harvest, hunting seasons, and bag limits. The act stipulates that, except as permitted by regulations, it is unlawful at any time, by any means, or in any manner to pursue, hunt, take, capture, or kill any migratory bird.

- **National Historic Preservation Act (16 USC 470 et seq.)**

The National Historic Preservation Act provides for placement of sites with significant national historic value on the National Register of Historic Places. Permits and certifications are not required under the act; however, consultation with the Advisory Council on Historic Preservation is required if a federal undertaking might impact a historic property resource. This consultation generally results in a memorandum of agreement that includes stipulations to minimize adverse impacts to the historic resource. Coordination with the State Historic Preservation Office is undertaken to ensure that potentially significant sites are properly identified, and appropriate mitigation measures are implemented.

- **Native American Graves Protection and Repatriation Act (25 USC 3001 et seq.)**

The Native American Graves Protection and Repatriation Act directs the Secretary of the Interior to guide federal agencies in the repatriation of federal archaeological collections and collections affiliated culturally to American Indian Tribes that are currently held by museums receiving federal funding. This act establishes provisions for the treatment of inadvertent discoveries of American Indians' remains and cultural objects. When discoveries are made during ground-disturbing activities, the following steps are to occur: 1) activity in the area of the discovery is to cease immediately, 2) reasonable efforts are to be made to protect the items discovered, 3) notice of discovery is to be given to the federal agency and the appropriate Tribes, and 4) a period of 30 days is to be set aside following notification for negotiations regarding the appropriate disposition of the discovered items.

- **National Environmental Policy Act (42 USC 4321 et seq.)**

The National Environmental Policy Act (NEPA) establishes a national policy that encourages awareness of the environmental consequences of human activities and promotes consideration of those environmental consequences during the planning and implementing stages of a project. Under NEPA, federal agencies are required to prepare detailed statements to address the environmental effects of proposed major federal actions that might significantly affect the quality of the human environment.

- **Pollution Prevention Act (42 USC 13101 et seq.)**

The Pollution Prevention Act establishes a national policy that pollution should be prevented or reduced at the source whenever feasible; pollution that cannot be prevented should be recycled in an environmentally safe manner, whenever feasible; pollution that cannot be prevented or recycled should be treated in an environmentally safe manner whenever feasible; and disposal or other release into the environment should be employed only as a last resort and should be conducted in an environmentally safe manner.

- **Resource Conservation and Recovery Act (RCRA) of 1976 as amended by the Hazardous and Solid Waste Amendments (42 USC 6901 et seq.) of 1984 (RCRA is also known as the Solid Waste Disposal Act)**

The treatment, storage, and/or disposal of hazardous and nonhazardous waste is regulated under the Solid Waste Disposal Act of 1965, which was amended by the Resource Conservation and Recovery Act of 1976 (RCRA), and the Hazardous and Solid Waste Amendments of 1984. Any state that seeks to administer and enforce a hazardous waste program pursuant to RCRA may apply for EPA authorization of the state program. The Washington State Department of Ecology (Ecology) has been delegated the authority for implementing the federal RCRA program in the state of Washington. The EPA regulations implementing RCRA define hazardous wastes and specify the transportation, handling, and waste management requirements of these wastes (40 CFR 260-282).

The Federal Facilities Compliance Act of 1992 (FFCA) (Public Law 102-386) amends RCRA and waives sovereign immunity for fines and penalties for RCRA violations at federal facilities. A provision of the FFCA postpones fines and penalties for 3 years for mixed waste storage prohibition violations at DOE sites and requires DOE to prepare plans for developing the required treatment capacity for mixed waste stored or generated at each facility. Each plan must be approved by the host state or the EPA after consultation with other affected states, and a consent order requiring compliance with the plan must be issued by the regulator. The FFCA also states that DOE will not be subject to fines and penalties for land disposal restriction storage prohibition violations for mixed waste as long as DOE is in compliance with an approved plan and consent order and meets all other applicable regulations. DOE, EPA, and the State of Washington had an existing plan (i.e., the Hanford Federal Facility Agreement and Consent Order [Tri-Party Agreement] [Ecology et al. 1989]) addressing compliance with the land disposal restrictions storage prohibition for mixed waste at the time this law was enacted.

- **Safe Drinking Water Act (42 USC 300f et seq.)**

The primary objective of the Safe Drinking Water Act is to protect the quality of public water supplies. The act grants EPA the authority to protect the quality of public drinking water supplies by establishing national primary drinking water regulations. EPA delegates authority for enforcement of the standards to the states. EPA regulations specify maximum contaminant levels in public water systems.

- **Toxic Substances Control Act (15 USC 2601 et seq.)**

The Toxic Substances Control Act provides EPA with the authority to require testing of chemical substances (both new and old) entering the environment and, where necessary, to regulate those chemicals. TSCA also regulates the treatment, storage, and disposal of certain toxic substances (e.g., polychlorinated biphenyls, chlorofluorocarbons, asbestos, dioxins, certain metal-working fluids, and hexavalent chromium).

- **Waste Isolation Pilot Plant Land Withdrawal Act (Public Law 102-579) and the Waste Isolation Pilot Plant Land Withdrawal Act Amendments (Public Law 104-201)**

The Waste Isolation Pilot Plant Land Withdrawal Act withdrew land from the public domain for the purposes of creating and operating the Waste Isolation Pilot Plant (WIPP), the geologic repository in New Mexico designated as the national disposal site for defense TRU waste. The act also defines the characteristics and amount of waste that will be disposed of at the facility. The amendments to the act exempt waste to be disposed of at WIPP from the RCRA land disposal restrictions.

## 6.1.2 Washington State Statutes

- **Washington State Hazardous Waste Management Act (RCW 70.105)**

The Washington Hazardous Waste Management Act grants Ecology authority to regulate the disposal of hazardous wastes in Washington and to implement waste reduction and prevention programs. Ecology has adopted extensive regulations that are found in chapter 173-303 of the Washington Administrative Code (WAC).

Washington State received authorization on January 30, 1986, effective January 31, 1986 (51 FR 3782), to implement the state's dangerous waste management program in lieu of the Federal RCRA hazardous waste management program. EPA has also granted authorization for various changes and updates to Washington's dangerous waste management program on September 22, 1987, effective on November 23, 1987 (52 FR 35556); August 17, 1990, effective October 16, 1990 (55 FR 33695); November 4, 1994, effective November 4, 1994 (59 FR 55322); February 29, 1996, effective April 29, 1996 (61 FR 7736); September 22, 1998, effective October 22, 1998 (63 FR 50531); on October 12, 1999, effective January 11, 2000 (64 FR 55142); and on April 11, 2002, effective April 11, 2002 (67 FR 17636).

- **Washington Clean Air Act (RCW 70.94)**

Most of the provisions of the Washington Clean Air Act mirror the requirements of the Federal Clean Air Act. The Federal Clean Air Act establishes a minimum or "floor" for Washington air quality programs. The Washington Clean Air Act authorizes Ecology and local air pollution control authorities to implement programs consistent with the Federal Clean Air Act. For example, the Washington Clean Air Act authorizes an operating permit program, enhanced civil penalties, new administrative enforcement provisions, motor vehicle inspections, and provisions addressing ozone and acid rain.

Ecology has an extensive set of regulations governing toxic air pollutants (WAC 173-460). These regulations are similar to the programs for regulating hazardous air pollutants under the Federal Clean Air Act. In contrast to the Federal Clean Air Act program, which applies to new and existing emission sources, the toxic air pollutant rules apply only to new sources and any modification of an existing source where the modification will increase emissions of toxic air pollutants. Ecology's toxic air pollutant rules are implemented under the New Source Review Program.

The Washington State Department of Health regulations, "Radiation Protection—Air Emissions" (WAC 246-247), contain standards and permit requirements for the emission of radionuclides to the atmosphere from DOE facilities based on Ecology standards, "Ambient Air Quality Standards and Emission Limits for Radionuclides" (WAC 173-480).

The local air authority, Benton Clean Air Authority, enforces regulations pertaining to detrimental effects, fugitive dust, incineration products, odor, opacity, asbestos, and sulfur oxide emissions. The Authority also has been delegated authority to enforce the EPA asbestos regulations.

- **Washington State Environmental Policy Act (RCW 43.21C)**

The Washington State legislature enacted the State Environmental Policy Act (SEPA) in 1971. Regulations implementing the act are in WAC 197-11. The purpose and policy sections of the statute are extremely broad, including recognition by the legislature that "each person has a fundamental and inalienable right to a healthful environment..." SEPA contains a substantive mandate that "policies, regulations, and laws of the State of Washington shall be interpreted and administered in accordance with the policies set forth in [SEPA]."

SEPA applies to all branches of state government, including state agencies, municipal and public corporations, and counties. It requires each agency to develop procedures implementing and supplementing SEPA requirements. Although SEPA does not apply directly to federal actions, the term "government action" with respect to state agencies is defined to include the issuance of licenses, permits, and approvals. Thus, as in NEPA, proposals (federal, state, or private) are evaluated, and may be conditioned or denied through the permit process, based on environmental considerations. SEPA does not create an independent permit requirement but overlays all existing Washington State agency permitting activities.

- **Model Toxics Control Act (RCW 70.105D)**

This act is implemented through the Hazardous Waste Cleanup – Model Toxics Control Act regulations found under WAC 173-340. The primary goal of these regulations is to provide a workable process to accomplish effective and expeditious cleanups that are not being conducted under CERCLA, in a manner that protects human health and the environment. It is primarily intended to address releases of hazardous substances caused by past activities, although its provisions may be applied to potential and ongoing releases of hazardous substances from current activities. These regulations also provide methodologies for calculating numeric cleanup levels for soils, groundwater, surface water, and air.

- **Water Pollution Control Act (RCW 90.48)**

The Washington Water Pollution Control Act establishes a permit system to license and control the discharge of pollutants into waters of the state. Under the permit system, dischargers must reduce releases to a level determined to be technologically and economically achievable, regardless of the condition of the receiving water. Dischargers also must maintain or improve the condition of the receiving water. The state has a general policy prohibiting degradation of existing water quality, and a variety of approaches are used to address the problem of toxic pollutants. Permits are required for both point-source and nonpoint source discharges.

Many of the preceding federal and Washington State statutes are further discussed in the following sections.

## 6.2 Land-Use Management

In September 1999, DOE issued the *Final Hanford Comprehensive Land-Use Plan Environmental Impact Statement* (DOE 1999). The Record of Decision (ROD) issued in November 1999 (64 FR 61615) states that the purpose of the land-use plan and its implementing policies is to facilitate decision making about Hanford Site uses and facilities over at least the next 50 years. The ROD adopts the Preferred Alternative land-use maps, designations, policies, and implementing procedures as described in the 1999 EIS and designates the Central Plateau (200 Areas) for Industrial-Exclusive use (Figure 4.2). This designation would allow for continued waste management operations in the 200 Areas.

The Hanford Reach National Monument was created on June 9, 2000, by a proclamation (65 FR 37253) signed by President Clinton under the authority of the Antiquities Act of 1906 (16 USC 431 et seq.). The Monument includes 792.6 km<sup>2</sup> (306 mi<sup>2</sup>) of federally owned land making up a portion of the Hanford Site (Figure 4.3). The principal components of the Monument are the Fitzner/Eberhardt Arid Lands Ecology Reserve (ALE), the McGee Ranch and Riverlands area, the Saddle Mountain National Wildlife Refuge, the quarter mile Hanford Reach Act (Hanford Reach Act [1988] as amended by Public Law 104-333) study strip along the south and west sides of the Columbia River corridor, the federally owned islands within the portion of the Columbia River included in the Monument, and the Hanford Sand Dune Field (Figure 4.3). FWS manages approximately 67,000 ha (166,000 ac) of Monument lands that are within ALE and the Wahluke Slope (Wahluke Unit and Saddle Mountain Unit) under permit from DOE. The Washington State Department of Fish and Wildlife manages approximately 324 ha (800 ac) of the Monument through a permit with DOE. The remainder of the Monument is managed by DOE. The June 9, 2000, proclamation does not affect the responsibilities and authority of DOE on Hanford Site lands nor does it affect DOE activities on lands not included within the Monument boundaries. In a separate memorandum to the Secretary of Energy, DOE was directed by the President to protect the natural values of the Hanford Site land not included within the Monument (Clinton 2000). DOE and FWS signed a Memorandum of Understanding on June 14, 2001, covering management responsibilities for the Monument. FWS issued a Notice of Intent to prepare a comprehensive conservation plan and associated EIS for the Monument in June 2002 (67 FR 40333).

DOE recently issued a policy directive covering DOE's use of institutional controls (DOE 2003d). DOE uses institutional controls for a variety of purposes including limiting access to land and facilities used for waste disposal operations. The policy directive provides that

- institutional controls will be used as essential components of a defense-in-depth strategy that uses multiple, relatively independent layers of safety to protect human health and the environment (including natural and cultural resources). This strategy employs a graded approach to attain a level of protection appropriate to the risks involved. DOE will use a graded approach to determine what types and levels of protective measures (e.g., physical, administrative, etc.) should be used.
- institutional controls will be implemented, along with other mitigating or preventive measures as necessary, to provide a reasonable expectation that if one control temporarily fails, other controls will be in place, or actions will be taken, to mitigate significant consequences of the failure. Institutional controls are not to be used to circumvent or substitute for permanent solutions when such solutions are reasonably achievable. Institutional controls will not be applied, or will be terminated, when DOE determines that such controls are not necessary or required.

The policy directive provides that DOE will maintain institutional controls as long as necessary to perform their intended protective purposes and will seek sufficient funding to maintain the controls.

Executive Order 11988 (42 FR 26951) directs federal agencies to establish procedures to ensure that the potential effects of flood hazards and floodplain management are considered for actions undertaken in a floodplain. The order further directs that floodplain impacts are to be avoided to the extent practicable. Executive Order 11990 (42 FR 26961) directs federal agencies to avoid, to the extent practicable, any short- and long-term adverse impacts on wetlands wherever there is a practicable alternative. DOE has issued regulations for compliance with Executive Orders 11988 and 11990 (10 CFR 1022).

### **6.3 Hanford Federal Facility Agreement and Consent Order**

The Hanford Federal Facility Agreement and Consent Order (Tri-Party Agreement [TPA]) is an agreement between DOE, the U.S. Environmental Protection Agency (EPA), and Ecology (Ecology et al. 1989) for achieving compliance at the Hanford Site with RCRA (42 USC 6901 et seq.), CERCLA (42 USC 9601 et seq.), and the Washington State Hazardous Waste Management Act. The TPA 1) defines CERCLA, RCRA, and Washington State cleanup commitments and sets due dates for those commitments, 2) establishes responsibilities among the agencies, and 3) reflects the goal of achieving regulatory compliance and completing remediation activities with enforceable milestones.

RCRA was enacted in 1976 and was significantly amended by the Hazardous and Solid Waste Amendments of 1984. RCRA establishes requirements covering handlers of hazardous waste, including generators, transporters, and those who own or operate hazardous waste treatment, storage, and disposal facilities. RCRA also authorizes EPA to regulate underground tank storage of substances other than hazardous waste and the disposal of nonhazardous solid waste. RCRA does not apply to any activity or substance that is subject to the Atomic Energy Act except to the extent that such application or regulation is not inconsistent with the requirements of the Atomic Energy Act [42 USC 6905(a)]. CERCLA is a



federal statute designed to respond to releases or threatened releases (e.g., past disposal) of hazardous substances. CERCLA provides EPA the authority to clean up sites where disposal of hazardous substances has occurred. Section 120 of CERCLA (42 USC 9620) provides that federal agencies are subject to and shall comply with CERCLA to the same extent as nongovernmental entities. Section 105 of CERCLA (42 USC 9605) directs EPA to prepare the national contingency plan (NCP) containing procedures for cleanup response actions. The plan appears at 40 CFR 300. The National Priorities List (NPL) is part of the NCP. Four areas of the Hanford Site (100, 200, 300, and 1100) were listed on the NPL in November 1989. The 1100 Area was subsequently delisted. The TPA was entered into in 1989 in anticipation that the Hanford Site would be placed on the NPL. The Washington Hazardous Waste Management Act provides the statutory basis for the regulation of hazardous waste in Washington.

## 6.4 Hazardous Waste Management

Hazardous waste management (including the management of hazardous components of radioactive mixed waste) at the Hanford Site is regulated by Ecology and EPA pursuant to RCRA and the Washington State Hazardous Waste Management Act. Hazardous waste activities at Hanford are subject to regulation under RCRA by virtue of Section 6001 of RCRA.

Ecology's regulations are consistent with, and at least as stringent as, the EPA regulations implementing RCRA. Under RCRA, *hazardous wastes* are regulated. The waste categories defined in the Ecology regulations (WAC 170-303) are *dangerous wastes*, *acutely hazardous waste*, *extremely hazardous wastes*, and *special wastes*.

Hazardous waste treatment, storage, and/or disposal (TSD) facilities are regulated under Section 3004 of RCRA and are required to have a permit by Section 3005 of RCRA. The Hanford Site received interim status for its existing TSD units when the RCRA program became applicable to DOE activities. The existing units, as required, are being encompassed in a RCRA final status permit, which is being amended over time to include final status or closure conditions for these units. The Hanford Site RCRA permit is in two portions, one portion issued by EPA Region 10 and the other portion issued by Ecology. The EPA portion of the RCRA permit covers the Hazardous and Solid Waste Amendments portion of the RCRA permit (EPA 1994). The second portion of the Hanford Site RCRA permit covers the dangerous waste provisions and was most recently modified by Ecology in February 2001 (Ecology 2001a). The Ecology portion of the RCRA permit includes standard conditions, general facility conditions, and specific conditions for individual operating TSD units, TSD units undergoing corrective action, and TSD units undergoing closure. The RCRA permits, along with other environmental permits covering the Hanford Site, are described in the *Annual Hanford Site Environmental Permitting Status Report* (DOE 2002a).

For all alternatives, the non-radioactive hazardous components of mixed waste would be stored at the Hanford Site in accordance with applicable EPA and Ecology regulations. Treatment and disposal of radioactive mixed wastes would be conducted in accordance with applicable hazardous (or dangerous) waste standards and regulations at the Hanford Site or offsite locations.

Storage and disposal of waste containing polychlorinated biphenyls (PCBs) would meet the EPA requirements in 40 CFR 761. These regulations are issued under the Toxic Substances Control Act (TSCA; 15 USC 2601 et seq.). DOE, EPA, and Ecology signed a “Framework Agreement for Management of Polychlorinated Biphenyls in Hanford Tank Waste” in August 2000 (EPA 2000). DOE issued a *Toxic Substances Control Act Polychlorinated Biphenyls Hanford Site Users Guide* in 2001 (DOE 2001f).

## 6.5 Radioactive Waste Management

DOE facilities used for the management, storage, treatment, and disposal of radioactive waste and radioactive mixed waste are constructed and operated under the authority of the AEA. DOE directives are issued under the authority of Section 161(i)(3) of the AEA that permits DOE to govern activities authorized by the act to protect health and to minimize danger to life or property.

The principal DOE directive covering radioactive waste management is DOE Order 435.1, *Radioactive Waste Management* (DOE 2001d). This Order states that DOE radioactive waste shall be managed to accomplish the following:

1. Protect the public from exposure to radiation from radioactive materials. Requirements for public radiation protection are in DOE Order 5400.5, *Radiation Protection of the Public and the Environment* (DOE 1993b).
2. Protect the environment. Requirements for environmental protection are in DOE Order 450.1, *Environmental Protection Program* (DOE 2003a), and DOE Order 5400.5, *Radiation Protection of the Public and the Environment* (DOE 1993b).
3. Protect workers. Requirements for radiation protection of workers are in 10 CFR 835, “Occupational Radiation Protection.” Requirements for industrial safety are in DOE Order 440.1A, *Worker Protection Management for DOE Federal and Contractor Employees* (DOE 1998).
4. Comply with applicable federal, state, and local laws and regulations; applicable Executive Orders; and other DOE directives.
5. Meet the requirements in DOE Manual 435.1-1, *Radioactive Waste Management Manual* (DOE 2001e). DOE Manual 435.1-1 has specific requirements applicable to management of high-level waste in Chapter II, management of TRU waste in Chapter III, and management of low-level waste (LLW) and mixed LLW (MLLW) in Chapter IV. The DOE Manual provides that a site-specific radiological performance assessment is to be prepared by DOE and maintained for DOE LLW disposed of after September 26, 1988. The performance assessment is to include calculations for a 1,000-year period after closure of potential doses to representative future members of the public and potential releases from the facility to provide a reasonable expectation that the performance objectives identified in Chapter IV of the DOE Manual are not exceeded as a result of operation and closure of the facility. The point of compliance is to correspond to the point of highest projected dose

or concentration beyond a 100-meter buffer zone surrounding the disposed of waste. A larger or smaller buffer zone may be used if adequate justification is provided.

DOE recently issued DOE Order 450.1, *Environmental Protection Program* (DOE 2003a). The objective of the Order is to implement sound stewardship practices that are protective of the air, water, land, and other natural and cultural resources impacted by DOE operations and by which DOE meets or exceeds compliance with applicable environmental, public health, and resource protection laws, regulations, and DOE requirements. This objective will be accomplished by implementing Environmental Management Systems (EMSs) at DOE sites. An EMS is a continuing cycle of planning, implementing, evaluating, and improving processes and actions undertaken to achieve environmental goals. These EMSs will be part of Integrated Safety Management Systems established pursuant to DOE's *Safety Management System Policy* (DOE 1996b).

## 6.6 Radiological Safety Oversight

Specific requirements in 10 CFR 830 apply to DOE contractors, DOE personnel, and other persons conducting activities (including providing items and services) that affect, or may affect, the safety of DOE nuclear facilities. The regulations in 10 CFR 830 include requirements for quality assurance (10 CFR 830, Subpart A) and safety-basis requirements (10 CFR 830, Subpart B). The safety-basis requirements require the contractor responsible for a DOE nuclear facility to analyze the facility, the work to be performed, and the associated hazards; and to identify the conditions, the safe boundaries, and the hazard controls necessary to protect workers, the public, and the environment from adverse consequences. DOE relies on these analyses and hazard controls to operate facilities safely. The requirements for nuclear safety management in 10 CFR 830 apply to the activities being considered in this HSW EIS.

DOE has requirements for occupational radiation protection in 10 CFR 835 that establish radiation-protection standards, limits, and program requirements for protecting individuals from ionizing radiation resulting from the conduct of DOE activities. The requirements are applicable to general employees involved in activities being considered in the HSW EIS that have the potential to result in the occupational exposure of an individual to radiation or radioactive material. The 10 CFR 835 requirements are further discussed in Section 6.8.

The Price-Anderson Act, Section 170 of the AEA, provides a system of indemnification for legal liability resulting from a nuclear incident in connection with contractual activity for DOE. An extensive discussion of the Price-Anderson Act is included in the Yucca Mountain Final EIS (DOE 2002d).

Many DOE directives that affect radiological safety apply to constructing and operating the facilities addressed in the HSW EIS. Among the more significant directives are the following:

- DOE Order 420.1A, *Facility Safety* (DOE 2002c), establishes facility safety requirements related to nuclear safety design, criticality safety, fire protection, and the mitigation of phenomena related to natural hazards.

- DOE Order 425.1C, *Startup and Restart of Nuclear Facilities* (DOE 2003c), establishes DOE requirements for startup of new nuclear facilities and for the restart of existing nuclear facilities that have been shut down. The requirements specify a readiness review process that must demonstrate that it is safe to start (or restart) the applicable facility. The facility must be started (or restarted) only after documented independent reviews of readiness have been conducted and the approvals specified in the Order have been received.
- DOE Policy 441.1, *DOE Radiological Health and Safety Policy* (DOE 1996a), states that it is DOE policy to conduct its radiological operations in a manner that ensures the health and safety of all its employees, contractors, and the general public. The Policy states that in achieving this objective, DOE will ensure that radiation exposures to its workers and the public and releases of radioactivity to the environment are maintained below regulatory limits, and deliberate efforts are taken to further reduce exposures and releases to as low as reasonably achievable (ALARA). DOE is committed to implementing a radiological control program of the highest quality that consistently reflects this Policy.
- DOE Order 5400.5, *Radiation Protection of the Public and the Environment* (DOE 1993b), establishes standards and requirements for DOE operations for protection of members of the public and the environment against undue risk from radiation. It is DOE policy to implement legally applicable radiation-protection standards and to consider and adopt, as appropriate, recommendations by authoritative organizations, for example, the National Council on Radiation Protection and Measurements and the International Commission on Radiological Protection. It is also DOE policy to adopt and implement standards generally consistent with those of the U.S. Nuclear Regulatory Commission (NRC) for DOE facilities and activities not subject to NRC licensing authority.
- DOE Order 5480.20A, *Personnel Selection, Qualification, and Training Requirements for DOE Nuclear Facilities* (DOE 2001c), establishes the selection, qualification, and training requirements for DOE contractor personnel involved in the operation, maintenance, and technical support of DOE nuclear reactors and non-reactor nuclear facilities. DOE objectives under this Order are to ensure the development and implementation of contractor-administered training programs that provide consistent and effective training for personnel at DOE nuclear facilities. The Order contains minimum requirements that must be included in training and qualification programs.

## 6.7 Radiation Protection of the Public and the Environment

DOE standards for radiation protection of the public and the environment are set out in DOE Order 5400.5 (DOE 1993b). In addition to establishing a general limit for public dose from DOE activities, the Order requires DOE activities to be conducted in a manner that complies with regulations issued by other government agencies, as applicable. The Order also specifies standards for radiological exposures to native aquatic animals. Requirements of the DOE Order and other applicable standards are discussed in this section.

Activities associated with any alternative under consideration in this HSW EIS would be managed in accordance with Chapter II of DOE Order 5400.5, which provides that DOE activities shall be conducted so that the exposure of members of the public to radiation sources, as a consequence of all routine DOE activities, shall not cause an effective dose equivalent exceeding 1 mSv/yr (100 mrem/yr).

In addition, radioactive emissions from DOE facilities are subject to the EPA National Emission Standards for Hazardous Air Pollutants requirements at 40 CFR 61. In particular, Subpart A (General Provisions), Subpart H (National Emission Standards for Emissions of Radionuclides Other than Radon from Department of Energy Facilities), and Subpart Q (National Emission Standards for Radon Emissions from Department of Energy Facilities) are applicable to all alternatives. Air emissions resulting from the implementation of any alternative would comply with the EPA 0.1-mSv/yr (10-mrem/yr) standard at 40 CFR 61.92. For all new construction or modifications to existing facilities where the estimated effective dose equivalent could exceed 1 percent of the 0.1-mSv/yr (10-mrem/yr) standard, an application for approval of construction or modification would be submitted to the appropriate regional EPA office under the procedures at 40 CFR 61.07 [see 40 CFR 61.96(b)].

New sources of radioactive emissions at Hanford are also subject to the licensing requirements of the Washington State Department of Health (WDOH) (WAC 246-247). DOE holds a license (No. FF-01) issued by the WDOH covering airborne radioactive effluents from Hanford operations. The license is incorporated as Attachment 2 in the Hanford Air Operating Permit (Ecology 2001b). DOE would submit a Notice of Construction to the WDOH, as required by WAC 246-247-060, before constructing or modifying any facility associated with any alternative under consideration in this HSW EIS that has projected radioactive emissions or changes in radioactive emissions. All new construction and significant modifications of emission units would use best available radionuclide control technology [WAC 246-247-040(3), WAC 173-480-060]. Standards and/or permits and license requirements (conditions) for applicable radiation and non-radiation emission unit compliance are compiled in the Hanford Air Operating Permit (Ecology 2001b).

DOE would ensure that U.S. Department of Transportation (DOT) radiation-level limitations for packaging in 49 CFR 173.441 are met and that requirements in 49 CFR 173.443 related to radioactive contamination on the external surfaces of each package offered for shipment are met. Transportation issues are further discussed in Section 6.11.

Chapter II of DOE Order 5400.5 states that it is DOE policy to provide an equivalent level of protection for persons consuming water from a drinking water supply operated by DOE or its contractors that corresponds to the maximum contaminant levels set forth in 40 CFR 141.15 and 141.16. Specifically, DOE Order 5400.5 states that DOE drinking water systems shall not cause persons consuming the water to receive an effective dose equivalent (calculated based on Federal Guidance Reports 11 and 12 [Eckerman et al. 1988, 1993]) greater than 4 mrem (0.04 mSv) in a year. Combined radium-226 and radium-228 shall not exceed  $5 \times 10^{-9}$   $\mu\text{Ci/mL}$ , and gross alpha activity (including radium-226, but excluding radon and uranium) shall not exceed  $1.5 \times 10^{-8}$   $\mu\text{Ci/mL}$ .<sup>(a)</sup> The maximum contaminant levels at

---

(a) In December 2000, EPA issued revised maximum contaminant levels for radionuclides to be effective in December 2003 (65 FR 76708). The new rule includes requirements for uranium.

40 CFR 141.15 and 141.16 are not directly applicable to groundwater and are used in this HSW EIS solely as a benchmark for water quality in the Hanford aquifer and the Columbia River for the long-term analysis.

DOE has a voluntary consensus technical standard that provides methods, models, and guidance within a graded approach that DOE personnel and contractors may use to characterize radiation doses to aquatic and terrestrial biota that are exposed to radioactive materials (DOE 2002b).

## 6.8 Occupational Safety and Occupational Radiation Exposure

Section 4(b)(1) of the Occupational Safety and Health Act of 1970 [29 USC 653(b)(1)] exempts DOE and its contractors from the occupational safety requirements of the U.S. Department of Labor Occupational Safety and Health Administration (OSHA). However, DOE Order 440.1A, *Worker Protection Management for DOE Federal and Contractor Employees* (DOE 1998), states that DOE will implement a written worker protection program that

- 1) provides a place of employment free from recognized hazards that are causing or are likely to cause death or serious physical harm to their employees, and 2) integrates all requirements contained in paragraphs 4a to 4l of DOE Order 440.1A; 29 CFR 1960, “Basic Program Elements for Federal Employee Occupational Safety and Health Programs and Related Matters”; and other related site-specific worker protection activities.

Relevant requirements in OSHA regulations and additional DOE-specified requirements are mandated by the DOE occupational, safety, and health program (DOE 1998).

DOE Order 5480.4, *Environmental, Safety, and Health Protection Standards* (DOE 1993a), requires that DOE and its contractors that are subject to this Order are to comply with the OSHA Occupational Safety and Health Standards at 29 CFR 1910.

The DOE radiation protection standards, limits, and program requirements for protecting occupational workers and visitors from ionizing radiation resulting from the conduct of DOE activities are in 10 CFR 835. All activities associated with any alternative would be conducted consistent with 10 CFR 835 requirements. The annual total effective dose equivalent (TEDE) limit for general employees is 0.05 Sv (5 rem) [10 CFR 835.202(a)(1)]. DOE policy is to maintain radiation exposure in controlled areas ALARA through facility and equipment design and administrative controls (10 CFR 835.1001). In addition, exposure of members of the public authorized to enter the controlled area where there are activities associated with implementing any alternative would not exceed 1 mSv (100 mrem) TEDE in a year (10 CFR 835.208). DOE Order 5480.4 specifies a number of American National Standards Institute standards applicable to radiation protection that DOE and its contractors must meet.

## 6.9 Non-Radioactive Air Emissions

Emissions of criteria or toxic pollutants from new sources would most likely be in small quantities under any alternative evaluated in the HSW EIS. Any such emissions would not be expected to require prevention of significant deterioration (PSD) permitting under 40 CFR 52.21 or WAC 173-400-141 because Hanford is within an area that is in attainment with or is unclassifiable for all national ambient air quality standards (40 CFR 81.348). New source review applicability for non-PSD criteria or toxic air permitting would be evaluated on a case-by-case basis under WAC 173-400-110 and WAC 173-460. All emissions of criteria or toxic pollutants would comply with applicable standards for air sources, as specified under the general air regulation (WAC 173-400). The EPA general conformity rule (40 CFR 93, Subpart B) requires that federal agencies prepare a written conformity analysis and determination covering compliance with an applicable state implementation plan for proposed activities if the total of direct and indirect emissions of a non-attainment or maintenance criteria pollutant caused by the activity would exceed the threshold emission levels shown at 40 CFR 93.153(b). General conformity is discussed in Section 5.2 of the HSW EIS. As noted earlier, the Washington State Clean Air Act authorizes Ecology and local air pollution control authorities to implement programs consistent with the Federal Clean Air Act.

## 6.10 State Waste Discharge Requirements

Ecology regulates industrial liquid waste discharges under the WAC 173-216 and WAC 173-218 permit programs. Ecology has issued the 200 Area Effluent Treatment Facility (ETF) Discharge Permit ST-4500 and the 200 Area Treated Effluent Disposal Facility (TEDF) Discharge Permit ST-4502 (DOE 2002a). Sanitary sewage discharges are approved under the onsite sewage system program (WAC 246-272).

## 6.11 Transportation Requirements

The transportation of all radioactive and other hazardous materials associated with any alternative selected for implementation would comply with applicable DOE directives and the regulations of EPA, DOT, and Ecology. Applicable DOE directives include DOE Order 460.1B, *Packaging and Transportation Safety* (DOE 2003b), DOE Order 460.2, *Departmental Materials Transportation and Packaging Management* (DOE 1995), and DOE Manual 460.2-1, *Radioactive Material Transportation Practices Manual* (DOE 2002e).

DOE Order 460.2 states that DOE operations shall be conducted in compliance with all applicable international, federal, state, local, and tribal laws, rules, and regulations governing materials transportation that are consistent with federal regulations, unless exemptions or alternatives are approved in accordance with DOE Order 460.1B (DOE 2003b). DOE Order 460.2 also states that it is DOE policy that shipments will comply with the DOT 49 CFR 106-180 requirements, except those that infringe upon maintenance of classified information.

DOE Order 460.1B establishes safety requirements for the proper packaging and transportation of DOE offsite shipments and onsite transfers of hazardous materials and for modal transport. Offsite is defined in the Order as any area within or outside a DOE site to which the public has free and uncontrolled access; onsite is defined as any area within the boundaries of a DOE site or facility to which access is controlled. The Order includes requirements for offsite packaging and transportation safety, special requirements for offsite shipment of radioactive material packaging, and quality assurance requirements. Offsite shipments of hazardous materials are to comply with applicable Department of Transportation (DOT) regulations. Onsite shipments of hazardous materials are to comply with DOT regulations or approved local requirements that provide equivalent safety. DOE Order 460.1B also requires an appropriate training program for persons involved in the packaging and transportation of DOE hazardous materials.

The Hazardous Materials Transportation Act (HMTA) (49 USC 5101 et seq.), as amended by the Hazardous Materials Transportation Uniform Safety Act of 1990, is the major Federal transportation-related statute affecting DOE. HMTA is implemented by regulations issued by the DOT Research and Special Programs Administration, Federal Highway Administration, Federal Railroad Administration, Federal Aviation Administration, and the U.S. Coast Guard.

Under the HMTA, DOT has requirements for marking, labeling, placarding, providing emergency response information, and training of hazardous material transport personnel at 49 CFR 172. Specific packaging requirements for radioactive materials are in 49 CFR 173, Subpart I. These requirements invoke the NRC packaging requirements for radioactive material as set forth in 10 CFR 71. DOT regulations for truck transportation of radioactive and other hazardous materials are in 49 CFR 172, 173, 177, 178, and 397. DOT regulations for rail transportation of radioactive and other hazardous materials are in 49 CFR 172, 173, 174, and 178. The Ecology regulations applicable to transportation of hazardous waste in Washington State are in WAC 173-303-240 through 270.

## **6.12 Cultural Resources**

The DOE policy on management of cultural resources (DOE 2001a) provides that

DOE will uphold [the National Historic Preservation Act, the Archaeological Resources Protection Act, and the Native American Graves Protection and Repatriation Act] by preserving, protecting, and perpetuating cultural resources for future generations in a spirit of stewardship to the extent feasible given the agency's mission and mandates. To do this, DOE will implement management accountability for compliance with Federal statutes, Executive Orders, treaties, DOE Orders, and implementation guidance. The Department also ensures that DOE contractors are obligated to implement DOE programs and projects in a manner that is consistent with this Policy and that reflects this commitment in site management contracts.



The background statement in *Management of Cultural Resources at Department of Energy Facilities* (DOE 2001b) further states that

DOE recognizes the cultural and scientific value of the resources that may exist on the properties under its management or over which it has direct or indirect control. Therefore, DOE has implemented a program to protect these resources and ensure that all DOE facilities and programs comply with all existing cultural resource Executive Orders, laws, and regulations. Thus, DOE is able to preserve, protect, and perpetuate cultural resources for future generations.

DOE (2001b) defines cultural resources to include “historic properties” as defined in the National Historic Preservation Act, “archaeological resources” as defined in the Archaeological Resources Protection Act of 1979, and “cultural items” as defined in the Native American Graves Protection and Repatriation Act (see Section 6.13).

The National Historic Preservation Act authorizes the Secretary of the Interior to maintain a National Register of Historic Places [16 USC 470a(a)(1)]. Federal agencies are to consider the effect of their actions on properties included in or eligible for inclusion in the Register and afford the Advisory Council on Historic Preservation a reasonable opportunity to comment on such actions (16 USC 470f).

The Archaeological Resources Protection Act of 1979 prohibits the excavation of material remains of past human life on public or Indian lands that have archaeological interest and are at least 100 years old without a permit from the appropriate federal land manager or an exemption (16 USC 470aa, 470bb, 470ee).

The Native American Graves Protection and Repatriation Act of 1990 prohibits the intentional excavation or removal of human remains or cultural items without a written permit, and prescribes protective measures and repatriative actions to be taken in the event that human remains or cultural items are discovered inadvertently (25 USC 3001 et seq.).

DOE and Hanford Site contractor compliance with cultural resources compliance legislation is discussed in Section 2.2.14 of the *Hanford Site Environmental Report for Calendar Year 2001* (Poston et al. 2002).

## **6.13 Treaties, Statutes, and Policies Relating to Native Americans**

DOE’s relationship with American Indians is based on treaties, statutes, Executive Orders, and DOE policy statements. Representatives of the United States negotiated treaties with leaders of various Columbia Plateau American Tribes and Bands in June 1855 at Camp Stevens in the Walla Walla Valley. The negotiations resulted in three treaties, one with the 14 tribes and bands of the group that would become the Confederated Tribes and Bands of the Yakama Nation, one with the three tribes that would

become the Confederated Tribes of the Umatilla Indian Reservation, and one with the Nez Perce Tribe. The U.S. Senate ratified the treaties in 1859. The negotiated treaties are as follows:

1. Treaty with the Walla Walla, Cayuse, etc. (June 9, 1855; 12 Stats. 945)
2. Treaty with the Yakama (June 9, 1855; 12 Stats. 951)
3. Treaty with the Nez Perce (June 11, 1855; 12 Stats. 957).<sup>(a)</sup>

The Confederated Tribes and Bands of the Yakama Nation, the Confederated Tribes of the Umatilla Indian Reservation, and the Nez Perce Tribe are federally recognized tribes that are eligible for funding and services from the Bureau of Indian Affairs by virtue of their status as Indian tribes (67 FR 46328).

The terms of the three preceding treaties are similar. Each of the three tribal organizations agreed to cede large blocks of land to the United States. The Hanford Site is within the ceded lands of the Yakama Nation and the Confederated Tribes of the Umatilla Indian Reservation. The treaties reserved to the Tribes certain lands for their exclusive use (the three reservations). The treaties also secured to the Tribes certain rights and privileges to continue traditional activities outside the reservations. These included 1) the right to fish at usual and accustomed places in common with other citizens of the United States, and 2) the privileges of hunting, gathering roots and berries, and pasturing horses and cattle on open and unclaimed lands. DOE believes that none of the activities involved in the HSW EIS would take place on open and unclaimed land.

The *U.S. Department of Energy American Indian and Alaska Native Tribal Government Policy* (DOE 2000) states, in part, that DOE

- recognizes the federal trust relationship with American Indians and Alaska Native Nations and will fulfill its trust responsibilities to them
- recognizes and commits to a government-to-government relationship and will institute appropriate protocols and procedures for program and policy implementation
- compliance with applicable federal cultural resource protection and other laws and Executive Orders will assist in preservation and protection of historic and cultural sites and traditional religious practices.

The American Indian Religious Freedom Act (42 USC 1996) establishes that U.S. policy is to protect and preserve for American Indians their inherent rights of freedom to believe, express, and exercise their traditional religions, including access to sites, use and possession of sacred objects, and the freedom to worship through ceremonies and traditional rites.

---

(a) The three treaties, as well as additional treaties, are included in Appendix A of the Hanford Comprehensive Land-Use Plan EIS (DOE 1999).

The Native American Graves Protection and Repatriation Act establishes the right of lineal descendants, Indian Tribes, and Native Hawaiian organizations to certain Native American human remains, funerary objects, sacred objects, or objects of cultural patrimony discovered on federal lands after November 16, 1990 (25 USC 3001 et seq.). When discovered during an activity on federal lands, the activity is to cease and appropriate tribal governments are to be notified. Work on the activity may resume, if resumption of the activity is otherwise lawful, 30 days after the receipt of certification that tribal governments have received the notice.

Executive Order 13007, "Indian Sacred Sites," (61 FR 26771) directs federal agencies, to the extent practicable, permitted by law, and not clearly inconsistent with essential agency functions, to 1) accommodate access to and ceremonial use of American Indian sacred sites by their religious practitioners, and 2) avoid adversely affecting the physical integrity of such sacred sites. Where appropriate, agencies are to maintain the confidentiality of sacred sites.

The DOE Richland Operations Office (DOE-RL) interacts and consults regularly and directly with the three federally recognized tribes affected by Hanford Site operations, that is, the Nez Perce Tribe, the Confederated Tribes of the Umatilla Reservation, and the Yakama Nation. In addition, the Wanapum, who still live adjacent to the Hanford Site, are a non-federally recognized tribe that has strong cultural ties to the Site. The Hanford area was also used by groups whose descendants are now enrolled members of the Confederated Tribes of the Colville Reservation. The Wanapum and the Confederated Tribes of the Colville Reservation are also consulted on cultural resource issues in accordance with DOE policy and relevant legislation.

## **6.14 Environmental Justice and Protection of Children**

Section 2-2 of Executive Order 12898, "Federal Actions to Address Environmental Justice in Minority Populations and Low-Income Populations," (59 FR 7629) states that

Each Federal agency shall conduct its programs, policies, and activities that substantially affect human health or the environment, in a manner that ensures that such programs, policies, and activities do not have the effect of excluding persons (including populations) from participation in, denying persons (including populations) the benefits of, or subjecting persons (including populations) to discrimination under, such programs, policies, and activities, because of their race, color, or national origin.

The CEQ has issued guidance for federal agencies to use in implementing Executive Order 12898 in conjunction with NEPA (CEQ 1997). DOE has also issued an information brief for DOE staff covering Executive Order 12898 (DOE 1997).

Section 1 of Executive Order 13045, "Protection of Children from Environmental Health Risks and Safety Risks," (62 FR 19885) requires federal agencies to

- make it a high priority to identify and assess environmental health risks and safety risks that may disproportionately affect children

- ensure that their policies, programs, activities, and standards address disproportionate risks to children that result from environmental health risks or safety risks.

## 6.15 Chemical Management

Chemical management would also be conducted according to DOE Order 5480.4, *Environmental Protection, Safety, and Health Protection Standards* (DOE 1993a), which requires DOE and its contractors to comply with National Fire Protection Association Codes and Standards and the Occupational Safety and Health Standards in 29 CFR 1910. The Hanford strategy for chemical management is described in Section 2.2.3 of the *Hanford Site Environmental Report for Calendar Year 2001* (Poston et al. 2002).

## 6.16 Emergency Planning and Community Right-to-Know

Part 5 of Executive Order 13148, “Greening the Government Through Leadership in Environmental Management,” (65 FR 24595) requires that federal executive branch agencies comply with the requirements for toxic chemical release reporting in Section 313 of the Emergency Planning and Community Right-to-Know Act (42 USC 11001). DOE’s compliance with the Emergency Planning and Community Right-to-Know Act at the Hanford Site is discussed in Section 2.2.5 of the *Hanford Site Environmental Report for Calendar Year 2001* (Poston et al. 2002). Compliance activities would be supplemented with any additional notification, planning, or reporting requirements that may arise.

## 6.17 Pollution Prevention

Part 5 of Executive Order 13148, “Greening the Government Through Leadership in Environmental Management,” (65 FR 24595) requires that federal executive branch agencies comply with Section 6607 of the Pollution Prevention Act (42 USC 13101 et seq.). Section 6607 requires that owners of a facility required to file an annual toxic chemical release form under Section 313 of the Emergency Planning and Community Right-to-Know Act (42 USC 11001) for any toxic chemical shall include with each such annual filing a toxic-chemical source reduction and recycling report for the preceding calendar year. DOE’s compliance with the Pollution Prevention Act at the Hanford Site is discussed in Section 2.2.5 of the *Hanford Site Environmental Report for Calendar Year 2001* (Poston et al. 2002). If implementation of any alternative considered in this HSW EIS were to trigger reporting under Section 313 of the Emergency Planning and Community Right-to-Know Act, DOE would comply with the reporting requirements and the requirement for a toxic-chemical source reduction and recycling report.

## 6.18 Endangered Species

Section 7 of the Endangered Species Act (16 USC 1536) requires that Federal agencies 1) use their authority in furtherance of the purposes of the act by carrying out programs for the conservation of listed endangered and threatened species, and 2) consult with appropriate Federal agencies to ensure that any action carried out by DOE is not likely to jeopardize the continued existence of any endangered or threatened species or result in the destruction or adverse modification of critical habitat for such species.

Additional information is provided in Sections 4.6.4 and 5.5.12 of this HSW EIS and in Section 2.2.12 of the *Hanford Site Environmental Report 2001* (Poston et al. 2002).

## 6.19 Permit Requirements

The CEQ regulations implementing NEPA [40 CFR 1502.25(b)] require that an EIS list all federal permits, licenses, and other entitlements that must be obtained to implement the alternatives.

DOE would obtain appropriate required permits for any new or modified facility. The exact nature and type of permits that would be needed cannot be known until the actual new or modified facilities are selected and defined with more precision. As an example, however, a new waste processing facility could require a variety of approvals, permits, or permit modifications, including:

- modification to the dangerous waste portion of the Hanford RCRA permit
- submission of a notice of construction to the WDOH
- modification of the Hanford Air Operating Permit
- construction approval by EPA under 40 CFR 61
- approval from EPA under TSCA and the regulations in 40 CFR 761(d) if waste containing PCBs is treated or disposed of at the facility
- approval from WDOH for onsite sewage disposal under WAC 246-272.

As another example, permits might be required for operating pulse driers to process leachate.

A list of permits and approvals that may be required to implement the disposal alternatives is shown in Table 6.1. In some cases, specific operating requirements or pollution control equipment would be required to ensure compliance with environmental quality regulations. New trenches could require a variety of approvals, permits, or permit modifications, including a modification to the dangerous waste portion of the Hanford RCRA permit. The disposal facility could be subject to the landfill design

**Table 6.1.** Potential Permits and Approvals Needed for Storage and Disposal

Activity and Waste Type	Regulatory Action Required	Regulation or Directive	Regulatory Agency
Air emissions	Controls for new sources of toxic and hazardous air pollutants	WAC 173-460, 40 CFR 61	Ecology and EPA
Air emissions	Notice of Construction, licensing, and possible sitewide air operating permit modification	WAC 173-400, WAC 246-247	WDOH and Ecology
Dangerous (including mixed) waste generation, storage, treatment, and disposal	Dangerous waste permit, RCRA permit	WAC 173-303, 40 CFR 260-280	Ecology and EPA
Radiological	Disposal authorization statement	DOE Manual 435.1-1	DOE

requirements as specified in “Standards for Owners and Operators of Hazardous Waste Treatment, Storage, and Disposal Facilities” (40 CFR 264, Subpart N), and WAC 173-303-665. The primary design features mandated by these regulations are the leachate collection system and the trench liner system (double liners, primary, and secondary).

New LLW trenches at Hanford would be designed, sited, operated, and closed in accordance with the DOE *Radioactive Waste Management Manual* (DOE 2001e). Chapter IV.P of the DOE Manual contains radiological performance objectives for DOE LLW disposal facilities. Chapter IV.P also requires preparation and periodic updating of 1) a performance assessment to demonstrate compliance with the performance objectives, and 2) a composite analysis, which considers all sources of radioactive material that may be left at the DOE site and may interact with the LLW disposal facility. The point of compliance in the performance assessment corresponds to the point of highest projected dose or concentration beyond a 100-meter buffer zone surrounding the disposed of waste. A larger or smaller buffer zone may be used if adequate justification is provided. Chapter IV.M of the DOE Manual contains design requirements and general design criteria that would be applied to a new LLW disposal facility.

Information developed for the HSW EIS plus site-specific design information developed in the future would be used in preparing the performance assessment and composite analysis for a potential new LLW disposal facility. Chapter IV.R of the DOE Manual specifies that DOE LLW disposal facilities will have a monitoring plan designed to measure and evaluate 1) releases, 2) migration of radionuclides, 3) disposal unit subsidence, and 4) changes in disposal facility and disposal site parameters which may affect long-term performance. LLW disposal facilities at DOE sites must be approved in advance by the DOE Headquarters Office of Environmental Management.

New MLLW trenches would be designed, sited, operated, and closed in accordance with the DOE *Radioactive Waste Management Manual* (DOE 2001e) and with applicable Ecology dangerous waste regulations and EPA RCRA regulations. A permit from Ecology would be needed (WAC 173-303-800). A permit would only be issued if the siting criteria in WAC 173-303-282, the performance standards in WAC 173-303-283, and the requirements for landfills in WAC 173-303-665 are satisfied. Construction on a new MLLW trench would not begin until authorization is issued by Ecology. The Ecology regulations contain detailed requirements for groundwater monitoring and, as needed, corrective actions (WAC 173-303-645). The point of compliance with groundwater protection standards is specified in the final permit [WAC 173-303-645(6)]. Permits for a land disposal facility are reviewed by Ecology five years after the date of permit issuance and modified as necessary, as provided in WAC 173-303-830(3) [see WAC 173-303-806(11)(d)].

The principal existing Hanford facilities that would be involved in implementing the alternatives in the HSW EIS are the Central Waste Complex, 200 Area Effluent Treatment Facility (ETF), Liquid Effluent Retention Facility, LLW Trenches, MLLW Trenches, T Plant Complex, and the Waste Receiving and Processing Facility. Table 6.2 indicates whether operation of each of these facilities is covered in the existing dangerous waste portion of the Hanford RCRA permit (Ecology 2001a) for RCRA interim status or the Hanford Air Operating Permit (Ecology 2001b). In all cases where units are covered in the dangerous waste portion of the Hanford RCRA permit, the coverage is in Part III of the permit that contains unit-specific conditions for final status operations.

**Table 6.2.** Coverage of Hanford Solid Waste Management Units in Existing Permits

Unit	Dangerous Waste Portion of Hanford RCRA Permit/Interim Status <sup>(a)</sup>	Hanford Air Operating Permit
Central Waste Complex	Yes	Yes
200 Area ETF	Yes	Yes
Liquid Effluent Retention Facility	Yes	Yes
LLW Trenches	Extent of applicability under discussion	Yes
MLLW Trenches	Yes	Yes
T Plant Complex	Yes	Yes
Waste Receiving and Processing Facility	Yes	Yes
(a) Interim status currently, final status in process.		

## 6.20 References

10 CFR 71. “Packaging and Transportation of Radioactive Material.” Code of Federal Regulations. Online at: [http://www.access.gpo.gov/nara/cfr/waisidx\\_01/10cfr71\\_01.html](http://www.access.gpo.gov/nara/cfr/waisidx_01/10cfr71_01.html)

10 CFR 830. “Nuclear Safety Management.” Code of Federal Regulations. Online at: [http://www.access.gpo.gov/nara/cfr/waisidx\\_02/10cfr830\\_02.html](http://www.access.gpo.gov/nara/cfr/waisidx_02/10cfr830_02.html)

10 CFR 835. “Occupational Radiation Protection.” Code of Federal Regulations. Online at: [http://www.access.gpo.gov/nara/cfr/waisidx\\_02/10cfr835\\_02.html](http://www.access.gpo.gov/nara/cfr/waisidx_02/10cfr835_02.html)

10 CFR 1021. “DOE National Environmental Policy Act Implementing Procedures.” Code of Federal Regulations. Online at: [http://www.access.gpo.gov/nara/cfr/waisidx\\_02/10cfr1021\\_02.html](http://www.access.gpo.gov/nara/cfr/waisidx_02/10cfr1021_02.html)

10 CFR 1022. “Compliance with Floodplain/Wetlands Environmental Review Requirements.” Code of Federal Regulations. Online at: <http://www.access.gpo.gov/nara/cfr/index.html>

29 CFR 1910. “Occupational Safety and Health Standards.” Code of Federal Regulations. Online at: [http://www.access.gpo.gov/nara/cfr/waisidx\\_01/29cfr1910\\_01.html](http://www.access.gpo.gov/nara/cfr/waisidx_01/29cfr1910_01.html)

29 CFR 1960. “Basic Program Elements for Federal Employee Occupational Safety and Health Programs and Related Matters.” Code of Federal Regulations. Online at: [http://www.access.gpo.gov/nara/cfr/waisidx\\_01/29cfr1960\\_01.html](http://www.access.gpo.gov/nara/cfr/waisidx_01/29cfr1960_01.html)

40 CFR 50-99. “Clean Air Act/Air Programs.” Code of Federal Regulations. Online at: <http://www.gpoaccess.gov/cfr/index.html>

- 40 CFR 52. “Approval and Promulgation of Implementation Plans.” Code of Federal Regulations. Online at: [http://www.access.gpo.gov/nara/cfr/waisidx\\_02/40cfrv3\\_02.html](http://www.access.gpo.gov/nara/cfr/waisidx_02/40cfrv3_02.html)
- 40 CFR 61. “National Emission Standards for Hazardous Air Pollutants.” Code of Federal Regulations. Online at: [http://www.access.gpo.gov/nara/cfr/waisidx\\_02/40cfr61\\_02.html](http://www.access.gpo.gov/nara/cfr/waisidx_02/40cfr61_02.html)
- 40 CFR 63. “National Emissions Standards for Hazardous Air Pollutants for Source Categories.” Code of Federal Regulations. Online at: [http://www.access.gpo.gov/nara/cfr/waisidx\\_02/40cfrv9\\_02.html](http://www.access.gpo.gov/nara/cfr/waisidx_02/40cfrv9_02.html)
- 40 CFR 81. “Designation of Areas for Air Quality Planning Purposes.” Code of Federal Regulations. Online at: [http://www.access.gpo.gov/nara/cfr/waisidx\\_01/40cfr81\\_01.html](http://www.access.gpo.gov/nara/cfr/waisidx_01/40cfr81_01.html)
- 40 CFR 93. “Determining Conformity of Federal Actions to State and Federal Implementation Plans.” Code of Federal Regulations. Online at: [http://www.access.gpo.gov/nara/cfr/waisidx\\_01/40cfr93\\_01.html](http://www.access.gpo.gov/nara/cfr/waisidx_01/40cfr93_01.html)
- 40 CFR 141. “National Primary Drinking Water Regulations.” Code of Federal Regulations. Online at: [http://www.access.gpo.gov/nara/cfr/waisidx\\_01/40cfr141\\_01.html](http://www.access.gpo.gov/nara/cfr/waisidx_01/40cfr141_01.html)
- 40 CFR 260-282. “Resource Conservation and Recovery Act Regulations.” Code of Federal Regulations. Online at: <http://www.gpoaccess.gov/cfr/index.html>
- 40 CFR 300. “National Oil and Hazardous Substances Pollution Contingency Plan.” Code of Federal Regulations. Online at: [http://www.access.gpo.gov/nara/cfr/waisidx\\_02/40cfr300\\_02.html](http://www.access.gpo.gov/nara/cfr/waisidx_02/40cfr300_02.html)
- 40 CFR 761. “Polychlorinated Biphenyls (PCBs) Manufacturing, Processing, Distribution in Commerce, and Use Prohibitions.” Code of Federal Regulations. Online at: [http://www.access.gpo.gov/nara/cfr/waisidx\\_01/40cfr761\\_01.html](http://www.access.gpo.gov/nara/cfr/waisidx_01/40cfr761_01.html)
- 40 CFR 1500-1508. “Council on Environmental Quality Regulations for Implementing the Procedural Provision of the National Environmental Policy Act.” Code of Federal Regulations. Online at: [http://www.access.gpo.gov/nara/cfr/waisidx\\_01/40cfrv28\\_01.html](http://www.access.gpo.gov/nara/cfr/waisidx_01/40cfrv28_01.html)
- 49 CFR 106-180. “Subtitle B—Other Regulations Relating to Transportation. Chapter I. Research and Special Programs Administration.” Code of Federal Regulations. Online at: [http://www.access.gpo.gov/nara/cfr/waisidx\\_02/49cfrv2\\_02.html](http://www.access.gpo.gov/nara/cfr/waisidx_02/49cfrv2_02.html)
- 49 CFR 397. “Transportation of Hazardous Materials: Driving and Parking Rules.” Code of Federal Regulations. Online at: <http://www.access.gpo.gov/nara/cfr/index.html>
- 42 FR 26951. “Executive Order 11988. Floodplain Management.” *Federal Register* (May 24, 1977).
- 42 FR 26961. “Executive Order 11990. Protection of Wetlands.” *Federal Register* (May 24, 1977).



51 FR 3782. “Washington; Final Authorization of State Hazardous Waste Management Program.” *Federal Register* (January 30, 1986).

52 FR 35556. “Final Authorization of State Hazardous Waste Management Program; Washington.” *Federal Register* (September 22, 1987).

55 FR 33695. “Washington; Final Authorization of State Hazardous Waste Management Program.” *Federal Register* (August 17, 1990).

59 FR 55322. “Washington; Final Authorization of State Hazardous Waste Management Program Revisions.” *Federal Register* (November 4, 1994). Online at: <http://www.gpoaccess.gov/fr/index.html>

59 FR 7629. “Executive Order 12898 of February 11, 1994: Federal Actions to Address Environmental Justice in Minority Populations and Low-Income Populations.” *Federal Register* (February 16, 1994). Online at: <http://www.gpoaccess.gov/fr/index.html>

61 FR 7736. “Washington; Final Authorization of State Hazardous Waste Management Program Revisions.” *Federal Register* (February 29, 1996). Online at: <http://www.gpoaccess.gov/fr/index.html>

61 FR 26771. “Executive Order 13007 of May 24, 1996: Indian Sacred Sites.” *Federal Register* (May 29, 1996). Online at: <http://www.gpoaccess.gov/fr/index.html>

62 FR 19885. “Executive Order 13045 of April 21, 1997: Protection of Children from Environmental Health Risks and Safety Risks.” *Federal Register* (April 23, 1997). Online at: <http://www.gpoaccess.gov/fr/index.html>

63 FR 50531. “Washington; Final Authorization of State Hazardous Waste Management Program Revision.” *Federal Register* (September 22, 1998). Online at: <http://www.gpoaccess.gov/fr/index.html>

64 FR 55142. “Washington; Final Authorization of State Hazardous Waste Management Program Revision.” *Federal Register* (October 12, 1999). Online at: <http://www.gpoaccess.gov/fr/index.html>

64 FR 61615. “Record of Decision: Hanford Comprehensive Land-Use Plan Environmental Impact Statement (HCP EIS).” *Federal Register* (November 12, 1999). Online at: <http://www.gpoaccess.gov/fr/index.html>

65 FR 24595. “Executive Order 13148 of April 21, 2000. Greening the Government Through Leadership in Environmental Management.” *Federal Register* (April 26, 2000). Online at: <http://www.gpoaccess.gov/fr/index.html>

65 FR 37253. “Establishment of the Hanford Reach National Monument.” Proclamation 7319 of June 9, 2000 by the President of the United States of America. *Federal Register* (June 9, 2000). Online at: <http://www.gpoaccess.gov/fr/index.html>

65 FR 76708. "National Primary Drinking Water Regulations; Radionuclides; Final Rule." *Federal Register* (December 7, 2000). Online at: <http://www.gpoaccess.gov/fr/index.html>

67 FR 17636. "Washington; Final Authorization of State Hazardous Waste Management Program Revision." *Federal Register* (April 11, 2002). Online at: <http://www.gpoaccess.gov/fr/index.html>

67 FR 40333. "Notice of Intent to Prepare a Comprehensive Conservation Plan and Associated Environmental Impact Statement for Hanford Reach National Monument/Saddle Mountain National Wildlife Refuge." *Federal Register* (June 12, 2002). Online at: <http://www.gpoaccess.gov/fr/index.html>

67 FR 46328. "Indian Entities Recognized and Eligible to Receive Services from the United States Bureau of Indian Affairs." *Federal Register* (July 12, 2002). Online at: <http://www.gpoaccess.gov/fr/index.html>

15 USC 2601 et seq. Toxic Substances Control Act (TSCA). Online at: <http://www4.law.cornell.edu>

16 USC 431 et seq. Antiquities Act of 1906 (American Antiquities Preservation Act). Online at: <http://www4.law.cornell.edu>

16 USC 469 et seq. Archaeological and Historic Preservation Act of 1979. Online at: <http://www4.law.cornell.edu>

16 USC 470aa et seq. Archaeological Resources Protection Act of 1979. Online at: <http://www4.law.cornell.edu>

16 USC 470 et seq. National Historic Preservation Act (NHPA) of 1966. Online at: <http://www4.law.cornell.edu>

16 USC 661 et seq. Fish and Wildlife Coordination Act. Online at: <http://www4.law.cornell.edu>

16 USC 668 et seq. Bald and Golden Eagles. Online at: <http://www4.law.cornell.edu>

16 USC 703 et seq. Migratory Bird Treaty Act. Online at: <http://www4.law.cornell.edu>

16 USC 1531 et seq. Endangered Species Act. Online at: <http://www4.law.cornell.edu>

25 USC 3001 et seq. Native American Graves Protection and Repatriation Act. Online at: <http://www4.law.cornell.edu>

29 USC 651, et seq. Occupational Safety and Health Act of 1970. Online at: <http://www4.law.cornell.edu>

33 USC 1251 et seq. Clean Water Act. Online at: <http://www4.law.cornell.edu>

42 USC 300f et seq. Safe Drinking Water Act. Online at: <http://www4.law.cornell.edu>

42 USC 1996. American Indian Religious Freedom Act. Online at: <http://www4.law.cornell.edu>

42 USC 2011 et seq. Atomic Energy Act (AEA) of 1954. Online at: <http://www4.law.cornell.edu>

42 USC 4321 et seq. National Environmental Policy Act (NEPA) of 1969, as amended. Online at: <http://www4.law.cornell.edu>

42 USC 6901 et seq. Resource Conservation and Recovery Act (RCRA) of 1976. Online at: <http://www4.law.cornell.edu>

42 USC 7401 et seq. Clean Air Act. Online at: <http://www4.law.cornell.edu>

42 USC 9601 et seq. Comprehensive Environmental Response, Compensation, and Liability Act (CERCLA) of 1980. Online at: <http://www4.law.cornell.edu>

42 USC 11001 et seq. Emergency Planning and Community Right-to-Know Act. Online at: <http://www4.law.cornell.edu>

42 USC 13101 et seq. Pollution Prevention Act of 1990. Online at: <http://www4.law.cornell.edu>

49 USC 5101 et seq. Hazardous Materials Transportation Act of 1994. Online at: <http://www4.law.cornell.edu>

CEQ. 1997. *Environmental Justice: Guidance Under the National Environmental Policy Act*. Council on Environmental Quality, Executive Office of the President, Washington, D.C. Online at: <http://ceq.eh.doe.gov/nepa/regs/ej/justice.pdf>

Clinton, W. J. 2000. "Memorandum from President William Clinton to the Secretary of Energy." June 9, 2000. Online at: <http://clinton6.nara.gov>

DOE. 1993a. *Environmental, Safety, and Health Protection Standards*. DOE Order 5480.4, U.S. Department of Energy, Washington, D.C. Online at: <http://www.directives.doe.gov>

DOE. 1993b. *Radiation Protection of the Public and the Environment*. DOE Order 5400.5, U.S. Department of Energy, Washington, D.C. Online at: <http://www.directives.doe.gov>

DOE. 1995. *Departmental Materials Transportation and Packaging Management*. DOE Order 460.2, U.S. Department of Energy, Washington, D.C. Online at: <http://www.directives.doe.gov>

DOE. 1996a. *DOE Radiological Health and Safety Policy*. DOE Policy 441.1, U.S. Department of Energy, Washington, D.C. Online at: <http://www.directives.doe.gov>

DOE. 1996b. *Safety Management System Policy*. DOE Policy 450.4, U.S. Department of Energy, Washington, D.C. Online at: <http://www.directives.doe.gov>

DOE. 1997. "Executive Order 12898, Federal Actions to Address Environmental Justice in Minority and Low-Income Populations." Environmental Justice Information Brief, EH-411-97/0001, U.S. Department of Energy, Washington, D.C. Online at: <http://homer.ornl.gov>

DOE. 1998. *Worker Protection Management for DOE Federal and Contractor Employees*. DOE Order 440.1A, U.S. Department of Energy, Washington, D.C. Online at: <http://www.directives.doe.gov>

DOE. 1999. *Final Hanford Comprehensive Land-Use Plan Environmental Impact Statement and Comprehensive Land-Use Plan*. DOE/EIS-0222-F, U.S. Department of Energy, Washington, D.C. Online at: <http://www.hanford.gov/eis/hraeis/maintoc.htm>

DOE. 2000. *U.S. Department of Energy American Indian and Alaska Native Tribal Government Policy*. U.S. Department of Energy, Washington, D.C. Online at: <http://www.ci.doe.gov/indianbk.pdf>

DOE. 2001a. *Department of Energy Management of Cultural Resources*. DOE Policy 141.1, U.S. Department of Energy, Washington, D.C. Online at: <http://www.directives.doe.gov>

DOE. 2001b. *Management of Cultural Resources at Department of Energy Facilities*. DOE/EH-412/0005r (revised July 2001), U.S. Department of Energy, Washington, D.C. Online at: <http://homer.ornl.gov>

DOE. 2001c. *Personnel Selection, Qualification, and Training Requirements for DOE Nuclear Facilities*. DOE Order 5480.20A, U.S. Department of Energy, Washington, D.C. Online at: <http://www.directives.doe.gov>

DOE. 2001d. *Radioactive Waste Management*. DOE Order 435.1 Change 1, U.S. Department of Energy, Washington, D.C. Online at: <http://www.directives.doe.gov>

DOE. 2001e. *Radioactive Waste Management Manual*. DOE Manual 435.1-1, U.S. Department of Energy, Washington, D.C. Online at: <http://www.directives.doe.gov>

DOE. 2001f. *Toxic Substances Control Act Polychlorinated Biphenyls Hanford Site Users Guide*. DOE/RL-2001-50, Rev. 0, U.S. Department of Energy, Richland, Operations Office, Richland, Washington.

DOE. 2002a. *Annual Hanford Site Environmental Permitting Status Report*. DOE/RL-96-63, Rev. 6, U.S. Department of Energy, Richland, Washington.

DOE. 2002b. "DOE Standard: A Graded Approach for Evaluating Radiation Doses to Aquatic and Terrestrial Biota." DOE-STD-1153-2002, U.S. Department of Energy, Washington, D.C. Online at: <http://tis.eh.doe.gov/techstds>

DOE. 2002c. *Facility Safety*. DOE Order 420.1A, U.S. Department of Energy, Washington, D.C. Online at: <http://www.directives.doe.gov>

DOE. 2002d. *Final Environmental Impact Statement for a Geologic Repository for the Disposal of Spent Nuclear Fuel and High-Level Radioactive Waste at Yucca Mountain, Nye County, Nevada*. DOE/EIS-0250F, U.S. Department of Energy, Washington, D.C.

DOE. 2002e. *Radioactive Material Transportation Practices Manual for Use with DOE O 460.2*. DOE Manual 460.2-1, U.S. Department of Energy, Washington, D.C. Online at: <http://www.directives.doe.gov/pdfs/doe/doetext/neword/460/m4602-1.pdf>

DOE. 2003a. *Environmental Protection Program*. DOE Order 450.1, U.S. Department of Energy, Washington, D.C. Online at: <http://www.directives.doe.gov>

DOE. 2003b. *Packaging and Transportation Safety*. DOE Order 460.1B, U.S. Department of Energy, Washington, D.C. Online at: <http://www.directives.doe.gov>

DOE. 2003c. *Startup and Restart of Nuclear Facilities*. DOE Order 425.1C, U.S. Department of Energy, Washington, D.C. Online at: <http://www.directives.doe.gov>

DOE. 2003d. *Use of Institutional Controls*. DOE Policy 454.1, U.S. Department of Energy, Washington, D.C. Online at: <http://www.directives.doe.gov>

Ecology, EPA, and DOE. 1989. *Hanford Federal Facility Agreement and Consent Order*. 89-10 (As Amended). Washington State Department of Ecology, U.S. Environmental Protection Agency, U.S. Department of Energy, Richland, Washington. Online at: <http://www.hanford.gov/tpa/tpahome.htm>

Ecology. 2001a. *Dangerous Waste Portion of the Resource Conservation and Recovery Act Permit for the Treatment, Storage, and Disposal of Dangerous Waste, Revision 7*. Washington State Department of Ecology Publication Number 94-05-001. Permit Number: WA7890008967. Olympia, Washington. Online at: <http://www.ecy.wa.gov>

Ecology. 2001b. *Hanford Air Operating Permit*. Washington State Department of Ecology Publication Number 00-05-006, Olympia, Washington. Online at: <http://www.ecy.wa.gov>

Eckerman, K. F., A. B. Wolbarst, and A. C. B. Richardson. 1988. *Limiting Values of Radionuclide Intake and Air Concentration and Dose Conversion Factors for Inhalation, Submersion, and Ingestion*. *Federal Guidance Report No. 11*. EPA-520/1-88-020, U.S. Environmental Protection Agency, Washington, D.C.

Eckerman, K. F. and J. C. Ryman. 1993. *External Exposure to Radionuclides in Air, Water, and Soil*. *Federal Guidance Report No. 12*. EPA 402-R-93-081, U.S. Environmental Protection Agency, Washington, D.C.

EPA. 1994. "Hazardous and Solid Waste Amendments Portion of the Resource Conservation and Recovery Act Permit for the Treatment, Storage, and Disposal of Hazardous Waste." September 28, 1994. U.S. Environmental Protection Agency, Region 10, Seattle, Washington. Online at: [http://yosemite.epa.gov/R10/OWCM.NSF/72b5220edcd9cf5b88256500005decf3/bdb1d43aa85483c5882569fa00660a3a/\\$FILE/hswa-per.pdf](http://yosemite.epa.gov/R10/OWCM.NSF/72b5220edcd9cf5b88256500005decf3/bdb1d43aa85483c5882569fa00660a3a/$FILE/hswa-per.pdf)

EPA. 2000. "Framework Agreement for Management of Polychlorinated Biphenyls (PCBs) in Hanford Tank Waste." August 31, 2000. U.S. Environmental Protection Agency, Region 10, Seattle, Washington. Online at: <http://yosemite.epa.gov/R10/OWCM.NSF/72b5220edcd9cf5b88256500005decf3/ce50d3fe12e371f488256a00006ffa0f?OpenDocument>

Hanford Reach Act. 1988. Public Law No. 100-605 as amended by Public Law 104-333. Online at: [http://206.61.210.104/pl/iap/html/body\\_apx-a.htm](http://206.61.210.104/pl/iap/html/body_apx-a.htm)

Poston, T. M., R. W. Hanf, R. L. Dirkes, and L. F. Morasch. 2002. *Hanford Site Environmental Report for Calendar Year 2001*. PNNL-13910, Pacific Northwest National Laboratory, Richland, Washington. Online at: <http://hanford-site.pnl.gov/envreport/2001/index.htm>

Treaty with the Walla Walla, Cayuse and Umatilla. 1855. June 9, 1855, 12 Stat. 945.

Treaty with the Yakama. 1855. June 9, 1855, 12 Stat. 951.

Treaty with the Nez Percés. 1855. June 11, 1855, 12 Stat. 957.

WAC 173-216. "State Waste Discharge Permit Program." Washington Administrative Code, Olympia, Washington. Online at: <http://www.leg.wa.gov/wac/index.cfm?fuseaction=chapterdigest&chapter=173-216>

WAC 173-218. "Underground Injection and Control Program." Washington Administrative Code, Olympia, Washington. Online at: <http://www.leg.wa.gov/wac/index.cfm?fuseaction=chapterdigest&chapter=173-218>

WAC 173-303. "Dangerous Waste Regulations." Washington Administrative Code, Olympia, Washington. Online at: <http://www.leg.wa.gov/wac/index.cfm?fuseaction=chapterdigest&chapter=173-303>

WAC 173-340. "Model Toxics Control Act – Cleanup." Washington Administrative Code, Olympia, Washington. Online at: <http://www.leg.wa.gov/wac/index.cfm?fuseaction=Section&Section=173-340>

WAC 173-400. "General Regulations for Air Pollution Sources." Washington Administrative Code, Olympia, Washington. Online at: <http://www.leg.wa.gov/wac/index.cfm?fuseaction=chapterdigest&chapter=173-400>

WAC 173-460. "Controls for New Sources of Toxic Air Pollutants." Washington Administrative Code, Olympia, Washington. Online at:  
<http://www.leg.wa.gov/wac/index.cfm?fuseaction=chapterdigest&chapter=173-460>

WAC 173-480. "Ambient Air Quality Standards and Emission Limits for Radionuclides." Washington Administrative Code, Olympia, Washington. Online at:  
<http://www.leg.wa.gov/wac/index.cfm?fuseaction=chapterdigest&chapter=173-480>

WAC 197-11. "SEPA Rules." Washington Administrative Code, Olympia, Washington. Online at:  
<http://www.leg.wa.gov/wac/index.cfm?fuseaction=chapterdigest&chapter=197-11>

WAC 246-247. "Radiation Protection – Air Emissions." Washington Administrative Code, Olympia, Washington. Online at:  
<http://www.leg.wa.gov/wac/index.cfm?fuseaction=chapterdigest&chapter=246-247>

WAC 246-272. On-Site Sewage Systems. Washington Administrative Code, Olympia, Washington. Online at: <http://www.leg.wa.gov/wac/index.cfm?fuseaction=chapterdigest&chapter=246-272>

Washington State Clean Air Act. RCW 70.94. Online at: <http://slc.leg.wa.gov>

Washington State Environmental Policy Act. RCW 43.21C. Online at: <http://slc.leg.wa.gov>

Washington State Hazardous Waste Management Act. RCW 70.105. Online at: <http://slc.leg.wa.gov>

Washington State Model Toxics Control Act. RCW 70.105D. Online at: <http://slc.leg.wa.gov>

Washington State Water Pollution Control Act. RCW 90.48. Online at: <http://slc.leg.wa.gov>

Waste Isolation Pilot Plant Land Withdrawal Act (Public Law 102-579).

Waste Isolation Pilot Plant Land Withdrawal Act Amendments (Public Law 104-201).

## 7.0 List of Preparers and Contributors

This section lists the individuals who played primary roles in the preparation of this final environmental impact statement (EIS) under the direction of the U.S. Department of Energy (DOE). The DOE multidisciplinary EIS Preparation Team was led by Michael Collins, DOE Richland Operations Office (RL), Waste Management Division, and Paul Dunigan, DOE-RL National Environmental Policy Act Compliance Officer. The EIS Preparation Team was responsible for developing the analytical methodology and alternatives, coordinating the work tasks, performing the impact analyses, and producing the document. DOE was responsible for data quality; procedural adequacy; the scope and content of the EIS; issue resolution; comment response resolution; review, revision, and writing of text and comment responses; and directing the EIS Preparation Team.

Pacific Northwest National Laboratory (PNNL) personnel provided primary assistance to DOE with assistance from other organizational staff. Wayne Johnson and Kathleen Rhoads, both of PNNL (managed by Battelle Memorial Institute for DOE), provided overall project management and document preparation support. Staff from Fluor Hanford Co., Inc.; Duratek Federal Services of Hanford; Duratek Federal Services, Northwest Operations; Jacobs Engineering Group Inc.; and CH2M Hill Hanford Group, Inc. provided technical support and operational data. Staff of EPA Region 10 and Washington State Department of Ecology reviewed portions of the revised draft HSW EIS. DOE independently evaluated all data and supporting information provided by these organizations. Further, DOE retained the responsibility for determining the appropriateness and adequacy of incorporating any data, analysis, and results of other work performed by these organizations in the EIS. The EIS Preparation Team was responsible for integrating such work into the EIS.

### Document Manager, U.S. Department of Energy, Richland Operations Office

**Name:** MICHAEL S. COLLINS

**Affiliation:** U.S. Department of Energy

**Education:** B.S., Chemical Engineering, Washington State University, 1986

**Technical Experience:** Project management, facility management (17 years)

**EIS Responsibility:** Document Manager, Reviewer/Contributor



## Document Support, U.S. Department of Energy, Office of River Protection

**Name:** GAE M. NEATH

**Affiliation:** U.S. Department of Energy

**Education:** B.S., Civil Engineering, University of Washington, 1988

**Technical Experience:** Project management, environmental management (15 years)

**EIS Responsibility:** Reviewer/Contributor

### DOE Reviewers and Contributors

DOE was responsible for policy, procedural adequacy, scope, format, and content of this EIS; issue resolution; and directing the EIS preparation assistance contractors. DOE independently evaluated data and supporting documentation for this EIS, selected the alternatives (including the preferred alternative), determined the level and methods of impact evaluation, performed detailed reviews, considered comments consideration and responses, and provided revised text where necessary.

**Name:** BENJAMIN F. BURTON

**Affiliation:** U.S. Department of Energy, Richland Operations Office

**Education:** M.S., Mechanical Engineering, Washington State University, 1983  
B.S., Mechanical Engineering, University of Washington, 1976

**Technical Experience:** Project management, facility management/engineering operations, NEPA, environmental compliance (35 years)

**EIS Responsibility:** Reviewer/Contributor – first draft

**Name:** **ROBERT M. CAROSINO**

**Affiliation:** U.S. Department of Energy, Richland Operations Office

**Education:** J.D., University of Washington School of Law, 1974  
B.A., Business Administration, University of Washington, 1971

**Technical Experience:** Environmental, contract and energy law (29 years)

**EIS Responsibility:** Reviewer/Contributor – revised draft and final; regulatory and policy issues; comment response

**Name:** **STEVEN E. CHALK**

**Affiliation:** U.S. Department of Energy, Richland Operations Office

**Education:** B.S., Marine Engineering, California Maritime Academy, 1972

**Technical Experience:** Regulatory compliance, safety analysis, environmental law, engineering management, nuclear facility operations (30 years)

**EIS Responsibility:** Reviewer/Contributor – revised draft

**Name:** **DOUGLAS H. CHAPIN**

**Affiliation:** U.S. Department of Energy, Richland Operations Office

**Education:** B.S., Biology, Whitworth College, 1975

**Technical Experience:** Environmental regulatory compliance, project management, NEPA (26 years)

**EIS Responsibility:** Reviewer/Contributor – first draft

**Name:** SUZANNE S. CLARK

**Affiliation:** U.S. Department of Energy, Richland Operations Office

**Education:** M.S., Physical Chemistry/Physiology and Biophysics, University of Washington, 1962  
B.S., Chemistry, University of Washington, 1958

**Technical Experience:** Project engineer, program, and facility management, NEPA (41 years)

**EIS Responsibility:** Reviewer/Contributor

**Name:** DENNIS W. CLAUSSEN

**Affiliation:** U.S. Department of Energy, Richland Operations Office

**Education:** B.S., Civil Engineering, University of Illinois, 1981

**Technical Experience:** Nuclear engineering, waste management, traffic (21 years)

**EIS Responsibility:** Reviewer/Contributor – transportation

**Name:** ERIC B. COHEN, P.E.

**Affiliation:** Office of NEPA Policy and Compliance, DOE-HQ

**Education:** M.S., Environmental Science in Civil Engineering, University of Illinois, 1979  
B.A., Chemistry and Biology, Western Maryland College, 1977

**Technical Experience:** NEPA, environmental restoration and compliance, wastewater engineering (24 years)

**EIS Responsibility:** Reviewer/Contributor

**Name:** PAUL F. X. DUNIGAN, JR.  
**Affiliation:** U.S. Department of Energy, Richland Operations Office  
**Education:** M.S., Environmental Science, Washington State University, 1973  
B.S., Biology, Gonzaga University, 1970  
**Technical Experience:** NEPA, environmental compliance, waste management (32 years)  
**EIS Responsibility:** NEPA Compliance Officer; Reviewer/Contributor

**Name:** THOMAS W. FERNS  
**Affiliation:** U.S. Department of Energy, Richland Operations Office  
**Education:** M.S., Land Rehabilitation, Montana State University, 1985  
B.S., General Studies, Southern Oregon State College, 1980  
B.S., Biology, Southern Oregon State College, 1980  
**Technical Experience:** CERCLA, NEPA, natural resources management (23 years)  
**EIS Responsibility:** Reviewer/Contributor

**Name:** WAYNE M. GLINES  
**Affiliation:** U.S. Department of Energy, Richland Operations Office  
**Education:** M.S., Radiological Sciences, University of Washington, 1983  
B.S., Physics, University of New Hampshire, 1971  
**Technical Experience:** Radiological program management and assessment, technical advisor  
(24 years)  
**EIS Responsibility:** Reviewer/Contributor – radiological assessment

**Name:** **RUDOLPH F. GUERCIA**

**Affiliation:** U.S. Department of Energy, Richland Operations Office

**Education:** B.S., Civil Engineering, Georgia Institute of Technology, 1981

**Technical Experience:** Registered P. E. (Virginia), waste management, nuclear documentation, project management (23 years)

**EIS Responsibility:** Reviewer/Contributor – waste inventory

**Name:** **R. LEO GUILLEN**

**Affiliation:** U.S. Department of Energy, Richland Operations Office

**Education:** B.S., Mechanical Engineering, University of Texas El Paso, 1976  
B.S., Sciences, Math, University of Texas El Paso, 1974

**Technical Experience:** Project design and development engineering, project management (29 years)

**EIS Responsibility:** HSW EIS project control support; Reviewer/Contributor – revised draft and final

**Name:** **R. DOUGLAS HILDEBRAND**

**Affiliation:** U.S. Department of Energy, Richland Operations Office

**Education:** B.S., Geology, Utah State University, 1974

**Technical Experience:** Geology, hydrogeology, mineral exploration, NEPA, environmental compliance, groundwater surveillance, performance assessments and composite analysis (26 years)

**EIS Responsibility:** Reviewer/Contributor – groundwater and cumulative impacts

**Name:** EDWARD V. HISKES

**Affiliation:** U.S. Department of Energy, Richland Operations Office

**Education:** L.L.M., Intellectual Property, University of Illinois, 1984  
J.D., University of Puget Sound, 1977  
B.S., Electrical Engineering, Washington State University, 1998  
B.A., Chemistry, University of Washington, 1984  
B.A., Political Science, University of Illinois, 1974

**Technical Experience:** Environmental and patent law, NEPA (20 years)

**EIS Responsibility:** Reviewer/Contributor – legal issues, comment response

**Name:** BETTY L. HOLLOWELL

**Affiliation:** U.S. Department of Energy, Richland Operations Office

**Education:** J.D., St. Mary's University School of Law, 1980  
B.A., Political Science, University of South Florida, 1976

**Technical Experience:** DOE attorney (23 years)

**EIS Responsibility:** Reviewer/Contributor

**Name:** MARY F. JARVIS

**Affiliation:** U.S. Department of Energy, Richland Operations Office

**Education:** Ph.D., Environmental Sciences, University of Texas, School of Public Health, 1982  
M.S., Environmental Engineering, University of Texas at Austin, 1975  
B.A., Microbiology, University of Texas at Austin, 1973

**Technical Experience:** Environmental sciences (30 years)

**EIS Responsibility:** Reviewer/Contributor – air and water, revised draft and final

**Name:** PHILIP E. LAMONT

**Affiliation:** U.S. Department of Energy, Office of River Protection

**Education:** M.S., Chemical Engineering, University of Idaho, 1975  
B.S., Chemical Engineering, Washington State University, 1965

**Technical Experience:** Nuclear chemical process development, radioactive waste management technology development, Hanford tank waste storage/disposal program (33 years)

**EIS Responsibility:** Reviewer/Contributor – tank wastes, ILAW

**Name:** ASTRID P. LARSEN

**Affiliation:** U.S. Department of Energy, Richland Operations Office

**Education:** B.S., Civil Engineering, Texas A&M University, 1985

**Technical Experience:** Environmental regulatory permitting and oversight (12 years)

**EIS Responsibility:** Reviewer/Contributor – air, first draft

**Name:** EDWARD J. LeDUC

**Affiliation:** Office of General Counsel, DOE-HQ

**Education:** J.D., University of Detroit, 1983  
B.S., Industrial and Operations Engineering, University of Michigan, 1980

**Technical Experience:** Environmental compliance (12 years)

**EIS Responsibility:** Reviewer/Contributor

**Name:** MARY M. McKNIGHT

**Affiliation:** U.S. Department of Energy, Richland Operations Office

**Education:** J.D., Creighton University School of Law, 1989  
B.A., Communications, University of Nebraska, 1982

**Technical Experience:** Environmental law, litigation, appropriations, labor law and procurement (13 years)

**EIS Responsibility:** Reviewer/Contributor – first draft

**Name:** MARLA K. MARVIN

**Affiliation:** U.S. Department of Energy, Richland Operations Office

**Education:** J.D., Washington College of Law, 1991  
B.A., Political Science and Psychology, Pacific Lutheran University, 1983

**Technical Experience:** Communications, writing, editing (17 years)

**EIS Responsibility:** Reviewer/Contributor; Author – summary

**Name:** ANNABELLE L. RODRIGUEZ

**Affiliation:** U.S. Department of Energy, Richland Operations Office

**Education:** B.S., Biology, University of Albuquerque, 1982

**Technical Experience:** Environmental analysis and permitting, NEPA, environmental justice, cultural and historical resources (15 years)

**EIS Responsibility:** Reviewer/Contributor – cultural and historical resources



**Name:** HECTOR M. RODRIGUEZ  
**Affiliation:** U.S. Department of Energy, Richland Operations Office  
**Education:** B.S., Geology, St. Mary's University, San Antonio, Texas, 1990  
**Technical Experience:** Environmental assessment and analysis (20 years)  
**EIS Responsibility:** Reviewer/Contributor

**Name:** DANA C. WARD  
**Affiliation:** U.S. Department of Energy, Richland Operations Office  
**Education:** B.A., Geoenvironmental Studies, University of Shippensburg, 1975  
**Technical Experience:** Geo-archaeology, radiation safety, environmental surveillance, NEPA (29 years)  
**EIS Responsibility:** Reviewer/Contributor

**Name:** DEBRA J. WILCOX  
**Affiliation:** U.S. Department of Energy, Richland Operations Office  
**Education:** J.D., Gonzaga University School of Law, 1984  
B.A., Political Science, University of Illinois-Chicago, 1977  
**Technical Experience:** Environmental law, environmental compliance, NEPA (19 years)  
**EIS Responsibility:** Reviewer/Contributor – revised draft and final; regulatory and policy issues; comment response

## Document Preparation Assistance Contractors

**Name:** CYNTHIA W. ABRAMS

**Affiliation:** Pacific Northwest National Laboratory

**Education:** B.A., Environmental Studies and Biology, University of California, Santa Cruz, 1980

**Technical Experience:** Ecological systems management, ecological risk assessment, CERCLA policy analysis, public involvement, and NEPA document preparation (16 years)

**EIS Responsibility:** Coordination of public comment database; comment response support

**Name:** JODI P. AMAYA

**Affiliation:** Pacific Northwest National Laboratory

**Education:** B.A., Business Administration, Washington State University, 1995

**Technical Experience:** Business management, analysis, and strategic planning; competitive intelligence; communications/public involvement (8 years)

**EIS Responsibility:** Coordination of public involvement activities; comment response support

**Name:** ERNEST J. ANTONIO

**Affiliation:** Pacific Northwest National Laboratory

**Education:** M.S., Environmental Health Physics, Colorado State University, 1992  
B.S., Biology, New Mexico Highlands University, 1988

**Technical Experience:** Environmental monitoring, environmental health physics, and dose assessment (12 years)

**EIS Responsibility:** Section 5, Deputy Task Manager, Environmental Consequences of Accidents; comment response support

**Name:** JAMES M. BECKER

**Affiliation:** Pacific Northwest National Laboratory

**Education:** M.S., Wildlife Science, University of Washington, 1989  
B.S., Range and Wildlife Ecology, Brigham Young University, 1987

**Technical Experience:** Ecological assessment, written and field documentation for NEPA analyses (9 years)

**EIS Responsibility:** Section 5, Ecological Resources; comment response support

**Name:** MARCEL P. BERGERON

**Affiliation:** Pacific Northwest National Laboratory

**Education:** M.A., Geology, Indiana University, 1979  
B.A., Geology, University of Vermont, 1975

**Technical Experience:** Hydrologic studies at a variety of hazardous waste and contaminated ground water sites (22 years)

**EIS Responsibility:** Section 5, Water Quality; comment response support

**Name:** JOE DWAYNE CRUMPLER

**Affiliation:** Jacobs Engineering Group Inc.

**Education:** M.S., Geology, Baylor University, 1989  
B.S., Geology, Lamar University, 1985

**Technical Experience:** RCRA corrective action, CERCLA remedial actions, water resources, geologic and mineral resources (15 years)

**EIS Responsibility:** Section 5, Water Resources

**Name:** PHILIP M. DALING

**Affiliation:** Pacific Northwest National Laboratory

**Education:** B.S., Physical Metallurgy, Washington State University, 1981

**Technical Experience:** Risk assessments for energy materials transportation systems, including preparation of transportation impact analyses for a wide variety of NEPA documents (20 years)

**EIS Responsibility:** Section 5, Transportation; comment response support

**Name:** THOMAS J. DeFOREST

**Affiliation:** Pacific Northwest National Laboratory

**Education:** B.S., Chemical Engineering, University of North Dakota, 1992

**Technical Experience:** Solid waste management system planning, forecasting, modeling, and alternatives analysis (10 years)

**EIS Responsibility:** Section 3, Description and Comparison of Alternatives; comment response support

**Name:** JOANNE P. DUNCAN

**Affiliation:** Pacific Northwest National Laboratory

**Education:** B.A., Biology, Hood College, Frederick, MD, 1979

**Technical Experience:** Ecological research, NEPA document preparation (7 years)

**EIS Responsibility:** Section 4, Affected Environment; comment response support

**Name:** PAUL W. ESLINGER

**Affiliation:** Pacific Northwest National Laboratory

**Education:** Ph.D., Statistics, Southern Methodist University, 1983  
M.A., Mathematics, Washington State University, 1978  
B.S., Mathematics, George Fox College, 1976

**Technical Experience:** Risk assessment, mathematical modeling (24 years)

**EIS Responsibility:** Section 5.14, Human Risk for Cumulative Impacts

**Name:** R. DOUGLAS EVANS

**Affiliation:** Jacobs Engineering Group Inc.

**Education:** M.S., Geology, University of Idaho, 1989  
B.S., Geology, University of Illinois, 1980

**Technical Experience:** Risk assessor, geologic and water resources, and field investigations (14 years)

**EIS Responsibility:** Section 5, Water Resources, Anticipated Health Effects

**Name:** A. LYNN FRANKLIN

**Affiliation:** Pacific Northwest National Laboratory

**Education:** Ph.D., Cognitive Psychology, University of Washington, 1995  
M.S., Electrical Engineering, Washington State University, 1980  
B.S., Electrical Engineering, University of Idaho, 1974

**Technical Experience:** Decision Sciences, Regulatory Analysis (10 years)

**EIS Responsibility:** Comment response support

**Name:** CLIFFORD S. GLANTZ

**Affiliation:** Pacific Northwest National Laboratory

**Education:** M.S., Atmospheric Sciences, University of Washington, 1982  
B.S., Physics and Atmospheric Sciences, State University of New York, Albany, 1979

**Technical Experience:** Research in environmental risk assessment and risk management, air pollution meteorology, and multipathway pollutant transport modeling (21 years)

**EIS Responsibility:** Section 5.2, Air Quality; comment response support

**Name:** PAUL E. GRAY

**Affiliation:** Pacific Northwest National Laboratory

**Education:** M.S., Environmental Science and Regional Planning, Washington State University Tri-Cities, Degree In Progress  
B.A., Political Science and Philosophy, University of New Hampshire, 1992

**Technical Experience:** Toxicology, database management, laboratory analysis (5 years)

**EIS Responsibility:** Database management, comment response support

**Name:** NOLAN S. HALE

**Affiliation:** Jacobs Engineering Group Inc.

**Education:** M.S., Chemistry, Brigham Young University, 1981

**Technical Experience:** Analytical chemistry laboratory and RCRA compliance (20 years)

**EIS Responsibility:** Section 5, Cumulative Impacts; Appendix A, Waste Inventory Data

**Name:** MICHAEL R. HARKER

**Affiliation:** Jacobs Engineering Group Inc.

**Education:** B.S., Zoology, Brigham Young University, 1989

**Technical Experience:** Risk assessment and health and safety analyst (20 years)

**EIS Responsibility:** Section 5, Geology and Soils, Air Quality, Transportation, Anticipated Health Effects, Accidents; Appendix C, Public Scoping; Appendix D, Consultations

**Name:** DAVID W. HARVEY

**Affiliation:** Pacific Northwest National Laboratory

**Education:** Post-graduate work, Urban Design & Planning, and Environmental Law, University of Washington, 1991-1993  
M.A., History and Historic Preservation, Western Washington University, 1975  
B.A., American Government and History, Fairleigh Dickinson University, 1970

**Technical Experience:** History, Historic Preservation, Cultural Resource Management and Planning (28 years)

**EIS Responsibility:** Section 5, Land Use and Cultural Resources Impacts; comment response support

**Name:** PAUL L. HENDRICKSON

**Affiliation:** Pacific Northwest National Laboratory

**Education:** J.D., Law, University of Washington, 1971  
M.S., Industrial Management, Purdue University, 1972  
B.S., Chemical Engineering, University of Washington, 1968

**Technical Experience:** Energy and environmental studies emphasizing regulatory issues (30 years)

**EIS Responsibility:** Section 6, Regulatory Framework; comment response support

**Name:** SUSAN T. HOLDERNESS

**Affiliation:** Jacobs Engineering Group Inc.

**Education:** Ph.D., Educational Administration, University of New Mexico, 1990  
M.S., Education, University of Southern California, 1972  
A.B., Political Science, Mount Holyoke College, 1969

**Technical Experience:** Regulatory specialist and public education (25 years)

**EIS Responsibility:** Section 5, Socioeconomics, Cumulative Impacts; Section 6, Statutory and Regulatory Requirements; Section 7, Scoping, Public Participation, and Consultations

**Name:** LEONARD R. HUESTIES

**Affiliation:** Pacific Northwest National Laboratory

**Education:** A.A., Columbia Basin College, 1991

**Technical Experience:** Resource management and public relations (26 years)

**EIS Responsibility:** Administrative record and resource library

**Name:** TRACY A. IKENBERRY

**Affiliation:** Dade Moeller & Associates, Inc.

**Education:** M.S., Radiation Health Science, Colorado State University, 1982  
B.S., Biology, McPherson College, 1979

**Technical Experience:** Radiological assessment, operational and environmental health physics (20 years). Diplomate, American Board of Health Physics

**EIS Responsibility:** Section 5, Environmental Consequences of Accidents; comment response support



**Name:** JOHN A. JAKSCH

**Affiliation:** Pacific Northwest National Laboratory

**Education:** Ph.D., Natural Resource Economics, Oregon State University, 1972  
M.S., Natural Resource Economics, Oregon State University, 1969  
B.S., Accounting and Business Administration, Southern Oregon College, 1966

**Technical Experience:** Cost/benefit analysis, evaluation of public policy, economic/financial incentives for environmental improvements (29 years)

**EIS Responsibility:** Section 5, Environmental Justice and Aesthetic Resources; comment response support

**Name:** WAYNE L. JOHNSON, P.E.

**Affiliation:** Pacific Northwest National Laboratory

**Education:** M.S., Engineering Management, Washington State University, 1995  
B.S., Nuclear Engineering, Oregon State University, 1983

**Technical Experience:** Project management, strategic planning, nuclear engineering, environmental restoration, waste management, nuclear facility D&D, and radiological controls (20 years). Professional Engineer, Nuclear.

**EIS Responsibility:** Project Manager, technical oversight

**Name:** CHARLES T. KINCAID

**Affiliation:** Pacific Northwest National Laboratory

**Education:** Ph.D., Engineering Utah State University, 1979  
B.S., Civil Engineering, Humboldt State College, 1970

**Technical Experience:** Fluid Movement and contaminant transport in subsurface systems including vadose zone and groundwater environments, preparation and review of performance assessments and a composite analysis for waste disposal at DOE sites under DOE Orders 5820.2A and 435.1, contributions to NEPA documents in the topical areas of vadose zone and groundwater contaminant transport.

**EIS Responsibility:** Appendix L, Simulation of Sidewide Contaminant Sources

**Name:** GEORGE V. LAST

**Affiliation:** Pacific Northwest National Laboratory

**Education:** M.S., Environmental Science, Washington State University, 1997  
B.S., Geology, Washington State University, 1976

**Technical Experience:** Geology, hydrology, hazardous waste site remedial investigations and feasibility studies (25 years)

**EIS Responsibility:** Vadose Zone section of the Systems Assessment Capability (SAC) appendix

**Name:** MEGAN E. LERCHEN

**Affiliation:** Pacific Northwest National Laboratory

**Education:** M.S., Inorganic Chemistry, University of Washington, 1989  
B.S., Chemistry, Portland State University, 1986

**Technical Experience:** Project management, waste management, environmental compliance, tank waste chemistry (13 years)

**EIS Responsibility:** Comment response support

**Name:** ANN M. LESPERANCE

**Affiliation:** Pacific Northwest National Laboratory

**Education:** M.S., Public Health, University of California at Los Angeles [UCLA], 1992  
B.A., Environmental Science and Latin American Studies, University of Wisconsin, Madison, 1980

**Technical Experience:** Project management, public/stakeholder involvement, public health, ecosystem management and policy (13 years)

**EIS Responsibility:** Regulator interface

**Name:** CHARLES A. LOPRESTI

**Affiliation:** Pacific Northwest National Laboratory

**Education:** M.S., Public Health (Industrial Hygiene), Tulane University, 1998  
B.S., Physics, University of Texas at Arlington, 1969

**Technical Experience:** Statistical computing, modeling (22 years)

**EIS Responsibility:** SAC Software Development Team, Vadose Zone Release Module

**Name:** NATESAN MAHASENAN

**Affiliation:** Pacific Northwest National Laboratory

**Education:** M.S., Engineering & Public Policy, Carnegie Mellon University, 1997  
M.S., Mechanical Engineering, Tulane University, 1994  
B.S., Mechanical Engineering, Birla Institute of Technology and Science (India), 1992

**Technical Experience:** Risk Assessment, Uncertainty Analysis, Quantitative Policy Analysis (6 years)

**EIS Responsibility:** Section 5, Transportation

**Name:** **STEPHEN E. MCKEE**

**Affiliation:** Jacobs Engineering Group Inc.

**Education:** B.S., Civil Engineering, Cornell University, 1995

**Technical Experience:** Variety of civil engineering projects (5 years)

**EIS Responsibility:** Section 3, Description and Comparison of Alternatives; Section 4, Affected Environment; Section 5, Biological and Ecological Resources, Cultural Resources, Land Use, Visual Resources, and Noise

**Name:** **THOMAS J. MCLAUGHLIN**

**Affiliation:** Pacific Northwest National Laboratory

**Education:** M.S., Public Health/Environmental Engineering, University of Hawaii, 1974  
B.S., Microbiology and Public Health, Washington State University, 1970

**Technical Experience:** Environmental Engineering, Mixed Waste Management, Regulations, NEPA (29 years)

**EIS Responsibility:** Data development interface

**Name:** **PETER L. MILLER**

**Affiliation:** Pacific Northwest National Laboratory

**Education:** B.S., Chemical Engineering, University of Illinois at Urbana, 1983

**Technical Experience:** Environmental regulation and project management (19 years). Licensed P.E., State of Washington.

**EIS Responsibility:** Comment response support

**Name:** DONALD G. MONTGOMERY

**Affiliation:** Jacobs Engineering Group Inc.

**Education:** B.S., Civil Engineering Construction Management, Oregon State University, 1975

**Technical Experience:** Estimator and construction manager for environmental remediation and operational and maintenance projects (30 years)

**EIS Responsibility:** Section 3, Description and Comparison of Alternatives; Section 5, Geology and Soils, Biological and Ecological Resources, Land Use, and Transportation

**Name:** NADIA HOPE MOORE

**Affiliation:** Pacific Northwest National Laboratory

**Education:** B.S., Chemistry, Pacific Lutheran University, 1992

**Technical Experience:** Toxicology (11 years)

**EIS Responsibility:** Section 5.0, Receipt of Public Comments, Comment Response Support

**Name:** DUANE A. NEITZEL

**Affiliation:** Pacific Northwest National Laboratory

**Education:** M.A., Biological Sciences, Washington State University, 1981  
B.S., Zoology, University of Washington, 1968

**Technical Experience:** Aquatic sciences with emphasis on salmonid fisheries of the Columbia River Basin, Pacific Northwest, U.S.A., and other western states. Emphasis on energy generation impacts to aquatic systems (31 years).

**EIS Responsibility:** Section 4, Affected Environment – lead and contributor to aquatic environment; comment response support

**Name:** IRAL C. NELSON

**Affiliation:** Pacific Northwest National Laboratory

**Education:** M.A., Physics, University of Oregon, 1955  
B.S., Mathematics, University of Oregon, 1951

**Technical Experience:** Various aspects of health physics (46 years), NEPA document preparation and review (31 years). Diplomate, American Board of Health Physics.

**EIS Responsibility:** Technical lead for Section 5, Environmental Consequences; comment response support

**Name:** DAVID L. NICHOLS

**Affiliation:** Jacobs Engineering Group Inc.

**Education:** B.S., Political Science and Communications, University of Iowa, 1980

**Technical Experience:** Public involvement tasks for DOE, EPA, DOD, and industry (air, water, and wetlands) projects (18 years)

**EIS Responsibility:** Section 1, Introduction; Section 2, Purpose and Need for Action

**Name:** WILLIAM E. NICHOLS

**Affiliation:** Pacific Northwest National Laboratory

**Education:** M.S., Civil Engineering, Oregon State University, 1990  
B.S., Agricultural Engineering, Oregon State University, 1987

**Technical Experience:** Hydrologist (13 years)

**EIS Responsibility:** Section 5, Cumulative Impacts Assessment

**Name:** LEILONI PAGE  
**Affiliation:** Jacobs Engineering Group Inc.  
**Education:** B.S., English, University of Idaho, 1992  
**Technical Experience:** Technical writer/editor and document production coordinator (12 years)  
**EIS Responsibility:** Editorial and production team lead for Jacobs Engineering Group Inc.

**Name:** DAVID R. PAYSON  
**Affiliation:** Pacific Northwest National Laboratory  
**Education:** B.A., Journalism, Central Washington University, 1978  
**Technical Experience:** Technical writing and editing (25 years)  
**EIS Responsibility:** Editorial and production team lead

**Name:** TED M. POSTON  
**Affiliation:** Pacific Northwest National Laboratory  
**Education:** M.S., Fisheries, University of Washington, 1978  
B.A., Biology, Central Washington University, 1973  
**Technical Experience:** Research, environmental assessment, and noise analysis (29 years)  
**EIS Responsibility:** Section 5, Noise Analysis; comment response support

**Name:** **KATHLEEN RHOADS**

**Affiliation:** Pacific Northwest National Laboratory

**Education:** M.S., Radiological Sciences, University of Washington, 1979  
B.S., Microbiology, University of Washington, 1972

**Technical Experience:** Radiological health and safety, waste management, environmental health physics, and risk assessment (29 years). Diplomate, American Board of Health Physics.

**EIS Responsibility:** Document Manager, technical oversight; comment response support

**Name:** **WAYNE A. ROSS**

**Affiliation:** Pacific Northwest National Laboratory

**Education:** M.S., Mechanical Engineering, Stanford University, 1969  
B.S., Ceramic Engineering, University of Utah, 1968

**Technical Experience:** Radioactive waste management (28 years)

**EIS Responsibility:** Section 2, Waste Streams and Facilities; Section 3, Alternatives; comment response support

**Name:** **MICHAEL J. SCOTT**

**Affiliation:** Pacific Northwest National Laboratory

**Education:** Ph.D., Economics, University of Washington, 1975  
M.A., Economics, University of Washington, 1971  
B.A., Economics, Washington State University, 1970

**Technical Experience:** Socioeconomic impacts of major projects and social policies (26 years)

**EIS Responsibility:** Section 5, Socioeconomics and Environmental Justice; comment response support



**Name:** **DILLARD B. SHIPLER**

**Affiliation:** Pacific Northwest National Laboratory

**Education:** M.S., Physics, University of Wisconsin, Milwaukee, 1967  
B.S., Math & Science, Southern Oregon College, Ashland, 1957

**Technical Experience:** Planning and executing research and development, operations, and support services programs related to regulatory compliance, radiological protection, environmental impact assessment, safety and risk analysis, emergency management, and radioactive waste management (41 years). Diplomat, American Board of Health Physics.

**EIS Responsibility:** Comment Response Document lead

**Name:** **SANDRA F. SNYDER**

**Affiliation:** Pacific Northwest National Laboratory

**Education:** M.S.P.H., Radiological Hygiene, University of North Carolina-Chapel Hill, 1991  
B.S., Environmental Resource Management, Pennsylvania State University, 1986

**Technical Experience:** Environmental health physics and risk assessment (11 years). Air quality analysis (6 years).

**EIS Responsibility:** Section 5, Air Quality; comment response support

**Name:** **LISSA H. STAVEN**

**Affiliation:** Pacific Northwest National Laboratory

**Education:** M.S., Health Physics, Colorado State University, 1990  
B.S., Environmental Conservation, University of New Hampshire, 1984

**Technical Experience:** Environmental health physics and low-level waste disposal management practices (12 years)

**EIS Responsibility:** Section 5, Database Management

**Name:** **ROBERT D. STENNER**

**Affiliation:** Pacific Northwest National Laboratory

**Education:** Ph.D., Toxicology, Washington State University, 1996  
M.S., Nuclear Engineering, Idaho State University, 1981  
B.S., Mechanics, University of Wisconsin (Stout Campus), 1970

**Technical Experience:** Toxicology, environmental health, exposure and health risk assessment (28 years)

**EIS Responsibility:** Section 5, comment response support

**Name:** **DENNIS L. STRENGE**

**Affiliation:** Pacific Northwest National Laboratory

**Education:** M.S., Chemical Engineering, University of Minnesota, 1968  
B.S., Chemical Engineering, University of Washington, 1966

**Technical Experience:** Environmental health physics and risk assessment (34 years)

**EIS Responsibility:** Section 5, Health and Safety; comment response support

**Name:** **LUCINDA L. SWARTZ**

**Affiliation:** Battelle Memorial Institute

**Education:** J.D., The Washington College of Law, The American University, 1979  
B.A., Political Science and Administrative Studies, University of California at Riverside, 1976

**Technical Experience:** Environmental law and regulation, NEPA compliance (24 years)

**EIS Responsibility:** Document summary; document reviews

## **Document Production Support**

- Lila Andor, Senior Communications Assistant
- Donna Austin-Workman, Graphics & Multimedia Design Specialist
- Jean Cheyney, Senior Communications Assistant Lead
- Cary Counts, Technical Editor
- Christopher DeGraaf, Graphics & Multimedia Design Specialist
- Jo Lynn Draper, Technical Editor
- Susan Ennor, Technical Editor
- Sharon Johnson, Technical Editor
- Anita Lebold, Publications Design Manager
- Kristin Manke, Document Index Specialist
- Shannon Neely, Graphics & Multimedia Design Specialist
- Kathy Neiderhiser, Senior Communications Assistant
- Zontziry Pritchett, Communications Specialist
- Trina Russell, Senior Communications
- Shanna Schmidt, Project Administrator
- Elaine Schneider, Senior Communications Assistant
- Rosalind Schrempf, Technical Editor
- Debora Schulz, Communications Specialist
- Antoinette Slavich, Technical Database Support
- Joanne Stover, Technical Editor
- Rose Urbina, Communications Assistant
- Barbara Wilson, Senior Communications Assistant
- Colleen Winters, Technical Editor

## **Hanford Technical Library**

- Nancy Doran, Assistant Director – Knowledge Management and Information Services
- Karen Buxton, Library Information Specialist
- Chrissie Noonan, Electronic Library Specialist
- Terrie Pettibon, Legal Library Specialist
- Janice Parthree, Senior Library Assistant

NEPA DISCLOSURE STATEMENT FOR PREPARATION OF THE  
HANFORD SITE SOLID (RADIOACTIVE AND HAZARDOUS)  
WASTE PROGRAM  
ENVIRONMENTAL IMPACT STATEMENT

CEQ Regulations at 40 CFR 1506.5(c), which have been adopted by the DOE (10 CFR 1021), require contractor who will prepare an EIS to execute a disclosure specifying that they have no financial or other interest in the outcome of the project. The term "financial or other interest in the outcome of the project" for purposes of this disclosure, is defined in the March 23, 1981, guidance "Forty Most Asked Questions Concerning CEQ's National Environmental Policy Act Regulations," 46 FR 18026-18038 at Questions 71a and b.

"Financial or other interest in the outcome of the project" includes "any financial benefit such as a promise of future construction or design work in the project, as well as indirect benefits the contractor is aware of (e.g., if the project would aid proposals sponsored by the firm's other clients)" 46 FR 18026-18038 at 18031.

In accordance with these requirements, Battelle Memorial Institute, Pacific Northwest Division hereby certifies as follows: check either (a) or (b).

- (a)  Battelle Memorial Institute, Pacific Northwest Division has no financial or other interest in the outcome of the referenced EIS projects.
- (b) \_\_\_\_\_ has the following financial or other interest in the outcome of the referenced EIS projects hereby agree to divest themselves of such interest prior to the start of the work.

Financial or Other Interest

- 1.
- 2.
- 3.

Certified by:

Nori Nichols  
Signature

Nori Nichols  
Name

Contracting Officer  
Title

April 9, 2002  
Date

NEPA DISCLOSURE STATEMENT FOR PREPARATION OF THE  
HANFORD SITE SOLID (RADIOACTIVE AND HAZARDOUS)  
WASTE PROGRAM  
ENVIRONMENTAL IMPACT STATEMENT

CEQ Regulations at 40 CFR 1506.5(c), which have been adopted by the DOE (10 CFR 1021), require contractor who will prepare an EIS to execute a disclosure specifying that they have no financial or other interest in the outcome of the project. The term "financial or other interest in the outcome of the project" for purposes of this disclosure, is defined in the March 23, 1981, guidance "Forty Most Asked Questions Concerning CEQ's National Environmental Policy Act Regulations," 46 FR 18026-18038 at Questions 71a and b.

"Financial or other interest in the outcome of the project" includes "any financial benefit such as a promise of future construction or design work in the project, as well as indirect benefits the contractor is aware of (e.g., if the project would aid proposals sponsored by the firm's other clients)" 46 FR 18026-18038 at 18031.

In accordance with these requirements, Jacobs Engineering Group Inc. hereby certifies as follows: check either (a) or (b).


(a)  Jacobs Engineering Group Inc. has no financial or other interest in the outcome of the reference EIS projects.

(b) \_\_\_\_\_ has the following financial or other interest in the outcome of the referenced EIS projects hereby agree to divest themselves of such interest prior to the start of the work.

Financial or Other Interest

- 1.
- 2.
- 3.

Certified by:



Signature

Steven Green

Name

Office Manager

Title

Date

2/18/2003

NEPA DISCLOSURE STATEMENT FOR PREPARATION OF THE  
HANFORD SITE SOLID (RADIOACTIVE AND HAZARDOUS)  
WASTE PROGRAM  
ENVIRONMENTAL IMPACT STATEMENT

CEQ Regulations at 40 CFR 1506.5 (c), which have been adopted by the DOE (10 CFR 1021), require contractor who will prepare an EIS to execute a disclosure specifying that they have no financial or other interest in the outcome of the project. The term "financial or other interest in the outcome of the project" for purposes of this disclosure, is defined in the March 23, 1981, guidance "Forty Most Asked Questions Concerning CEQ's National Environmental Policy Act Regulations," 46 FR 18026-18038 at Questions 71a and b.

"Financial or other interest in the outcome of the project" includes "any financial benefit such as a promise of future construction or design work in the project, as well as indirect benefits the contractor is aware of (e.g., if the project would aid proposals sponsored by the firm's other clients)" 46 FR 18026-18038 at 18031.

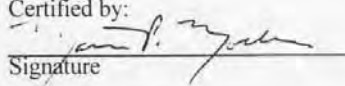
In accordance with these requirements, Dade Moeller & Associates, Inc. hereby certifies as follows: check either (a) or (b).

- (a)  X  Dade Moeller & Associates, Inc. has no financial or other interest in the outcome of the referenced EIS projects.
- (b) \_\_\_\_\_ has the following financial or other interest in the outcome of the referenced EIS projects hereby agree to divest themselves of such interest prior to the start of the work.

Financial or Other Interest

- 1.
- 2.
- 3.

Certified by:

  
Signature

Matthew P. Moeller

Name

President & Chief Operating Officer

Title

March 25, 2003

Date

## Consultations and Coordinations

To ensure full compliance with National Environmental Policy Act (NEPA) of 1969 (42 USC 4321) regulations and to help keep concerned Tribal Nations and agencies informed of DOE actions, DOE conducted various consultations and coordinations as listed below. These interactions consisted of written correspondence regarding the proposed action, alternatives, environmental impacts, regulatory requirements, and issues of concern. Copies of formal consultation letters and responses are included in Appendixes I and K of this EIS (Volume II).

- Confederated Tribes and Bands of the Yakama Nation
- Confederate Tribes of the Colville Reservation
- Confederated Tribes of the Umatilla Indian Reservation
- Hanford Communities (intergovernmental group for Benton and Franklin counties, Richland, Kennewick, Pasco, West Richland, and the Port of Benton)
- Hanford Advisory Board
- Hanford Natural Resources Trustee Council
- National Marine Fisheries Service
- Nez Perce Tribe
- Oregon Office of Energy
- U.S. Environmental Protection Agency, Region 10
- U.S. Fish and Wildlife Service
- Wanapum
- Washington State Department of Ecology
- Washington State Department of Health
- Washington State Office of Archaeology and Historic Preservation

## Cooperating Agencies

The early planning for the proposed ILAW SEIS included scope pertaining to the Waste Treatment Plant (WTP) construction. At that time, the Hanford Communities requested to become a cooperating agency (Attachment 1) with a primary interest in the socioeconomic impacts. In response, DOE welcomed the Hanford Communities as a cooperating agency (Attachment 2). The Hanford Communities commissioned Perteet Engineering, a company based in Everett, Washington to perform a socioeconomic study. Later DOE decided to limit the scope of the SEIS to ILAW disposal. When DOE subsequently decided to combine the SEIS with the HSW EIS, DOE asked the Hanford Communities if they wished to continue to participate as a cooperating agency (Attachment 3). No response was received.

In addition, DOE asked Ecology to participate as a cooperating agency in the proposed ILAW SEIS (Attachment 4). Ecology declined the offer (Attachment 5).

Soon after the Notice of Intent was issued, the Yakama Nation indicated that they wanted to be involved in the preparation of the HSW EIS (Attachment 6). DOE accepted the Yakama Nation's offer (Attachment 7). DOE subsequently requested clarification of the Yakama role (Attachment 8). For a time, a representative of the Yakama Nation staff participated in the preparation of the first draft of the HSW EIS. However, the Yakama Nation later decided that they no longer wished to participate (Attachment 9).



# Hanford Communities

## Attachment 1

*Richland • Kennewick • Pasco • West Richland • Benton County • Port of Benton*

P.O. Box 190, Richland, WA 99352  
Telephone (509) 942-7348 Fax (509) 942-7379

May 4, 2001

Dr. Harry Boston, Manager  
Office of River Protection  
P.O. Box 450, MSIN H6-60  
Richland, WA 99352

Dear Dr. Boston:

The Hanford Communities are very interested in the Supplemental Environmental Impact Statement (EIS) that your office is undertaking associated with the tank waste vitrification project. Of particular interest is the socio-economic impact section of the EIS. The construction of the vitrification plant will draw to our region thousands of workers during the peak construction years. This influx of people will have a significant impact on all of our communities, and Richland in particular. The construction of the nuclear power plants by the Washington Public Power Supply System (WPPSS) some twenty years ago resulted in a similar influx of people to the community for a several-year period of time.

Based on our experience with the WPPSS construction projects, our communities believe it is essential that we plan for, and to the extent possible mitigate the impacts that will occur during the construction of the vitrification plant. We are presently considering a proposal to hire a consulting firm to do a socio-impact analysis for us. The company we have chosen did the socio-economic impact analysis under NEPA for the Everett Home Port, which was constructed by the U.S. Navy in the late 80s. We are presently working to define the Scope of Work of the contract. We anticipate the project will be completed in July. A copy of the draft Scope of Work has been shared with your staff and the contractors that are working on the Supplemental EIS.

The cost of hiring Perteet Engineering to do the analysis is \$65,388. The Hanford Communities considered asking the Office of River Protection (ORP) to help us in covering this cost before proceeding with the project, but determined that such a request would result in a delay that was unacceptable. Since ORP will need to address socio-economic impacts in the EIS, and this study will provide the necessary information, we would appreciate it if you would consider providing funding to offsetting some of the consultant costs.

Because of our strong interest in developing sound information upon which we can rely for planning purposes, and the need for that analysis to be tied to accurate and complete information about your project, we would like to explore with you the option of the City of Richland serving as a cooperating agency during the preparation of the Supplemental EIS. This status would give Richland the opportunity to work with your staff to coordinate our efforts and to review draft documents for consistency as they are being developed.

**RECEIVED**

**MAY 08 2001**

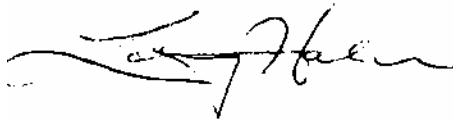
Attachment 1 (contd)

The cooperating agency status would be limited to the community, social and economic impact aspects of the EIS and we believe would best be defined in a Memorandum of Understanding.

The staff of our respective organizations met on April 26 to have a preliminary discussion on this topic. It was a very positive and constructive meeting. It was determined that the next step would be for us to write this letter to you and to begin discussion about a Memorandum of Understanding that would be definitive and acceptable to the Department of Energy and the Hanford Communities.

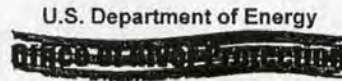
We look forward to your response, and we look forward to working with you on this project which is of paramount importance to our region.

Sincerely,

A handwritten signature in black ink, appearing to read "Larry Haler", written in a cursive style.

Larry Haler, Chairman  
Hanford Communities

Attachment 2



P.O. Box 450  
Richland, Washington 99352  
JUN 01 2001

01-EQD-047

Mr. Larry Haler, Chairman  
Hanford Communities  
P.O. Box 190  
Richland, Washington 99352

Dear Mr. Haler:

REQUEST FOR COOPERATING AGENCY STATUS ON THE TANK WASTE  
REMEDATION SYSTEM (TWRS) SUPPLEMENTAL ENVIRONMENTAL IMPACT  
STATEMENT (SEIS)

Reference: Hanford Communities letter from L. Haler to H. L. Boston, ORP, dated May 4,  
2001.

The U.S. Department of Energy, Office of River Protection (ORP) has reviewed the above  
Reference requesting cooperating agency status on the TWRS SEIS. ORP welcomes your  
participation as a cooperating agency. ORP looks forward to working with you on drafting a  
Memorandum of Understanding that defines your degree of involvement and your  
responsibilities for specific issues.

In regards to offsetting any costs associated with developing information and preparing  
environmental analyses for the SEIS, ORP regrets to inform you that federal funds are not  
available.

If you have any questions, please contact Gae M. Neath, Environmental and Quality Division,  
(509) 376-7828.

Sincerely,

A handwritten signature in black ink, appearing to read "H. L. Boston".

Harry L. Boston  
Manager

EQD:GMN

cc: P. F. X. Dunigan, Jr., RL  
D. Nichols, Jacobs

## Attachment 3



03-WMD-0097

**Department of Energy**  
Richland Operations Office  
P.O. Box 550  
Richland, Washington 99352  
JAN 22 2003

Ms. Pam Brown  
Hanford Communities  
P.O. Box 190  
Richland, Washington 99352

Dear Ms. Brown:

**HANFORD COMMUNITIES PARTICIPATION IN THE PREPARATION OF THE  
HANFORD SITE SOLID (RADIOACTIVE AND HAZARDOUS) WASTE PROGRAM  
ENVIRONMENTAL IMPACT STATEMENT (HSW EIS) (SECOND DRAFT)**

The U.S. Department of Energy has decided to evaluate the environmental impacts of several immobilized low activity waste (ILAW) disposal alternatives in the HSW EIS. Previous plans were to evaluate these alternatives as part of the Tank Waste Remediation System Supplemental Environmental Impact Statement (TWRS SEIS).

As you already know, the first draft of the HSW EIS was sent out to interested parties for review in May 2002. Comments received during that review were large, both in terms of numbers and significance. The U.S. Department of Energy decided to prepare a second draft in an effort to respond to comments on the first draft. Anticipated changes include:

- The addition of the same ILAW disposal alternatives that were to be addressed in the Tank Waste Remediation System Supplemental Environmental Impact Statement (TWRS SEIS) and the evaluation of those alternatives.
- The addition of alternatives for disposal of ILAW with low-level waste and mixed low-level waste and the evaluation of those alternatives.

Plans are to issue the second draft of the HSW EIS for review in March 2003.

The Hanford Communities had previously requested to be a cooperating agency for preparation of the TWRS SEIS, and had been accepted. Please advise us as soon as possible whether the Hanford Communities is interested in continuing to participate as a cooperating agency on this EIS and, if so, how you want to be involved.

Attachment 3 (contd)

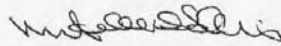
Ms. Pam Brown  
03-WMD-0097

-2-

JAN 22 2003

If you would like to discuss this matter or have any questions, feel free to call me on  
(509) 376-6536.

Sincerely,



Michael S. Collins  
Document Manager

WMD:MSC

cc: C. Borgstrom, EH-42

## Attachment 4



U.S. Department of Energy  
**Office of River Protection**

P.O. Box 450  
Richland, Washington 99352

SEP 06 2002

02-EMD-147

Mr. Michael A. Wilson, Program Manager  
Nuclear Waste Program  
State of Washington  
Department of Ecology  
1315 W. Fourth Avenue  
Kennewick, Washington 99336

Dear Mr. Wilson:

**INVITATION TO PARTICIPATE AS A COOPERATING AGENCY IN DEVELOPMENT OF  
THE TANK WASTE REMEDIATION SYSTEM, HANFORD SITE, RICHLAND,  
WASHINGTON, SUPPLEMENTAL ENVIRONMENTAL IMPACT STATEMENT (SEIS)**

The U.S. Department of Energy (DOE), Office of River Protection (ORP) is inviting you to participate in the development of the SEIS for Disposal of Immobilized Low-Activity Waste, consistent with the Council on Environmental Quality's (CEQ) Regulations for Implementing the Procedural Provisions of the National Environmental Policy Act, 40 CFR 1501.6. Consistent with the CEQ guidance, ORP will use the environmental analysis and proposals of cooperating agencies with jurisdiction by law or special expertise, to the maximum extent possible, consistent with its responsibility as lead agency. ORP is requesting that the State of Washington Department of Ecology provide information and analysis for those portions of the supplemental environmental impact statement in which you, as a cooperating agency, have special expertise. The addition of your specialized knowledge will be of great value to the planning process and will be incorporated into the SEIS. ORP looks forward to your cooperation, involvement, and staff assistance in the planning and development of the SEIS for the future disposition of the vitrified low-activity waste at Hanford.

ORP is proposing modifications to the tank waste program. To address the proposed changes, DOE decided to issue a supplement to the Tank Waste Remediation System EIS issued in 1996. The proposed changes include vitrifying low-activity tank waste as monoliths rather than cullet and permanently disposing the monoliths in regulatory compliant trenches in the 200 Areas, versus long-term storage in concrete vaults in the 200 East Area.

Once again, we would appreciate your participation in the development of the SEIS. Please advise by return mail your acceptance of this invitation to participate, to identify your point-of-contact, and to make arrangements for consultation meetings.



Attachment 4 (contd)

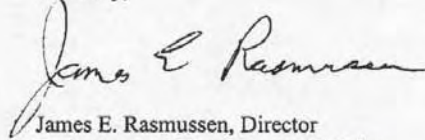
Mr. M. A. Wilson  
02-EMD-147

-2-

SEP 06 2002

Should you have any questions, please feel free to contact me, (509) 376 2247, or your staff may contact Gae M. Neath, Environmental Management Division, (509) 376-7828.

Sincerely,



James E. Rasmussen, Director  
Environmental Management Division

EMD:GMN

cc: M. Brown, Ecology  
S. L. Dahl, Ecology  
J. L. Hensley, Ecology  
Environmental Portal, LMSI  
P. F. X. Dunigan, RL

Attachment 5



STATE OF WASHINGTON  
DEPARTMENT OF ECOLOGY  
P.O. Box 47600 • Olympia, Washington 98504-7600  
(360) 407-6000 • TDD Only (Hearing Impaired) (360) 407-6006

October 10, 2002

Mr. James E. Rasmussen  
Director of Environmental Management Division  
Office of River Protection  
United States Department of Energy  
P.O. Box 550, MSIN: H6-60  
Richland, Washington 99352

Dear Mr. Rasmussen,

Re: Letter, James Rasmussen to Michael Wilson, "Invitation to Participate as Cooperating Agency in Development of the Tank Waste Remediation System, Hanford Site, Richland, Washington, Supplemental Environmental Impact Statement (SEIS)", September 6, 2002

The Washington State Department of Ecology (Ecology) appreciates the offer that you made on behalf of the United States Department of Energy (USDOE), Office of River Protection (ORP) to allow our agency to participate as a cooperating agency as defined in Title 40 Code of Regulations (CFR) Section 1508.5. At this time, Ecology has chosen to decline your offer; however, Ecology will comment during the USDOE scoping process (40 CFR 1501.7(a)) and during the public comment period following the issue of the draft supplement (40 CFR Part 1503).

From our discussions to date, we understand that you are now developing a supplement to the existing Tank Waste Remediation System Environmental Impact Statement. The intent of the supplement is to evaluate permanent disposal of the vitrified low activity tank waste in large trenches on the Hanford Site. Ecology will require that these trenches be constructed and operated to the standards in Washington Administrative Code (WAC) Chapter 173-303, Dangerous Waste Regulations, Section 665. To support the issue of a permit for the construction and operation of the trenches, Ecology will undertake timely reviews of the SEIS per WAC 197-11-055(1). Under the provisions of WAC 173-802-060, Ecology will also allow the USDOE to forego submission of an environmental checklist to support the permit application because the SEIS will be prepared. Ecology may consider adopting the SEIS if the provisions of WAC 197-11-610(3) are met to our agency's satisfaction.

If you have any questions regarding this issue, please contact the Tank Waste Disposal Project Manager, Ms. Suzanne Dahl (509) 736-5705.

Sincerely,

Michael Wilson  
Program Manager  
Nuclear Waste Program

SD:sb

cc: (See next page)



RECEIVED

OCT 16 2002

DOE-ORP/ORPCC



**Attachment 5 (contd)**

Mr. James E. Rasmussen  
October 10, 2002

cc: Todd Martin, HAB  
Richard Gay, CTUIR  
Pat Sobotta, NPT  
Russell Jim, YN  
Ken Niles, OOE  
Administrative Record: TWRS ILAW & TWRS EIS

Attachment 6

11/13/97 THU 16:22 FAX 509 452 2503

YAKIMA ER WM UG

002



Confederated Tribes and Bands  
of the Yakama Indian Nation

Established by the  
Treaty of June 9, 1855

Mr. John D. Wagoner, Manager  
U.S. Department of Energy  
Richland Operations Office  
P.O. Box 550, M/S A-750  
Richland WA 99352

November 13, 1997

SOLID WASTE EIS - PREFERRED ROLE OF THE YAKAMA INDIAN NATION

Dear Mr. Wagoner,

We have received the Solid Waste EIS Notice of Intent, and wish to participate as a co-preparer of the EIS. We would like to participate as a regular working member of the technical workgroup that meets Monday mornings. We would like to help develop the scope and outline of the EIS. We would expect to perform some of the analysis and write some sections that pertain to tribal resources and risks, as well as part of the environmental justice section. We will make our staff time available so that DOE's schedule will not be delayed.

We would also like an initial work session with DOE and the contractor staff to begin working on scope (inclusions and exclusions), the principles of cumulative impact analysis, and a number of related issues. Because there are several critical issues raised by the NOI, we would request that we begin working on this very soon. We are aware of the intertribal meeting tentatively scheduled Thanksgiving week, and would like to ensure that this is an actual working meeting (rather than simply an informational briefing) where the issues of scope and analytical method are included and open for discussion and possible modification. At that meeting we would also like to establish our roles and technical responsibilities as well as ongoing work session schedules.

Sincerely,

Russell Jim, Manager  
Environmental Restoration/Waste Management Program

cc: Allison Wright, DOE-RL  
Kevin Clarke, DOE-RL  
Donna Powaukee, NPT  
Stuart Harris, CTUIR  
Merilyn Reeves, HAB

Post Office Box 151, Fort Road, Toppenish, WA 98948 (509) 865-5121

Attachment 7



Department of Energy  
Richland Operations Office  
P.O. Box 550  
Richland, Washington 99352  
APR 13 1998

98-WPD-016

Mr. Russell Jim, Manager  
Environmental Restoration/  
Waste Management Program  
Confederated Tribes and Bands  
of the Yakama Indian Nation  
2808 Main Street  
Union Gap, Washington 98903

Dear Mr. Jim:

REQUEST FOR YAKAMA INDIAN NATION (YIN) TO BE A COOPERATING AGENCY IN PREPARATION OF THE HANFORD SITE SOLID (RADIOACTIVE AND HAZARDOUS) WASTE PROGRAM ENVIRONMENTAL IMPACT STATEMENT (EIS)

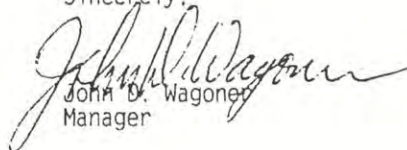
The U.S. Department of Energy, Richland Operations Office (RL), has considered the Yakama Indian Nation request to be a cooperating agency in the preparation of the Hanford Site Solid (Radioactive and Hazardous) Waste Program EIS. We appreciate the offer of assistance by the Yakama Indian Nation.

Following a meeting and telephone conversations with members of your staff, RL understands that your request for cooperating agency status is intended to provide the Yakama Indian Nation Environmental Restoration/Waste Management staff an opportunity to participate in the preparation of the subject EIS.

While we are unable to designate the Yakama Indian Nation as a "cooperating agency" in accordance with the Council on Environmental Quality Regulations, 40 CFR 1501.6, we are hopeful that we can accomplish the same ends by designating the Yakama Indian Nation a "consulting" agency in the same way as was offered to the Yakama Indian Nation in preparation of the Hanford Remedial Action EIS. As a "consulting" agency, the Yakama Indian Nation involvement would be similar to that of a cooperating agency in the preparation of the EIS that will lead to a U.S. Department of Energy Record of Decision. This involvement could include Yakama Indian Nation preparation or assistance in preparation of portions of the draft EIS, participation in EIS management meetings, and reviews of predecisional drafts. Such participation is consistent with your scope of work under the Cooperative Agreement (DE-FC06-90RL11979) and would be funded by your existing budget. Your specific involvement would be subject to our approval and mutual agreement, as well as an understanding of expectations for schedule and review processes.

Please contact Elizabeth M. Bowers on (509) 373-9276 or Paul F. X. Dunigan, Jr. on (509) 376-6667 to discuss the details of your involvement in the drafting of this EIS.

Sincerely,

  
JOHN D. WAGONE  
Manager

WPD:GLS

cc: T. Woods, YIN





## Attachment 8

**Department of Energy**  
Richland Operations Office  
P.O. Box 550  
Richland, Washington 99352

03-WMD-0096

Mr. Russell Jim, Manager  
Environmental Restoration/  
Waste Management Program  
Confederated Tribes and Bands  
of the Yakama Nation  
2808 Main Street  
Union Gap, Washington 98903

Dear Mr. Jim:

### YAKAMA NATION PARTICIPATION IN THE PREPARATION OF THE HANFORD SITE SOLID (RADIOACTIVE AND HAZARDOUS) WASTE PROGRAM ENVIRONMENTAL IMPACT STATEMENT (HSW EIS) (SECOND DRAFT)

The Yakama Nation had previously requested to be a cooperating agency for the preparation of the HSW EIS. The U.S. Department of Energy agreed to this request. As a cooperating agency, it was expected that the Yakama Nation would provide information and supporting analyses for inclusion. For a time, a representative of the Yakama Nation participated in the preparation of the first draft of the HSW EIS. We would like to know if the Yakama Nation is still interested in participating as a cooperating agency, helping to prepare the second draft HSW EIS.

As you already know, the first draft of the HSW EIS was sent out to interested parties for review in May 2002. Comments received during that review were large, both in terms of numbers and significance.

The U.S. Department of Energy has decided to prepare a second draft in an effort to respond to comments on the first draft. Anticipated changes include:

- The addition of alternatives for the disposal of immobilized low activity waste from the tank farms and evaluation of the impacts of those alternatives.
- The addition of more alternatives for the disposal of low-level waste and mixed low-level waste and evaluation of the impacts of those alternatives.
- The addition of alternatives for disposal of different waste types (immobilized low activity waste, low-level waste, mixed low-level waste) together and evaluation of the impacts of those alternatives.
- The evaluation of the additional impacts to the environment resulting from receipt of waste from offsite generators.
- The addition of information on the impacts of transporting waste especially as it pertains to the States of Washington and Oregon.
- The addition of a comment response document that summarizes the major issues from the first review and specific responses to each comment received.

JAN 23 2003


Mr. Russell Jim  
03-WMD-0096

Plans are to issue a second draft for review in March 2003.

Please advise us as soon as possible whether the Yakama Nation is interested in continuing as a cooperating agency in preparation of the second draft and, if so, how you want to be involved.

If you have any questions or comments, feel free to call me at (509) 376-6536.

Sincerely,



Michael S. Collins  
Document Manager

WMD:MSC

cc: C. M. Borgstrom, EH-42

## Attachment 9



Confederated Tribes and Bands  
of the Yakama Indian Nation

Established by the  
Treaty of June 9, 1855

27 February, 2003

Keith Klein, Manager  
U.S. Department of Energy  
Richland Operations Office  
P.O. Box 550 MSIN: A7-50  
Richland, WA 99352

**RE: Participation in the Preparation of the *Second Draft Hanford Site Solid (Radioactive and Hazardous) Waste Program Environmental Impact Statement, April 2002, DOE/EIS-0286D***

Dear Mr. Klein:

The Yakama Nation recently received a letter, dated January 23, 2003, from Mr. Michael S. Collins, Document Manager, of your staff inquiring about our participation as a cooperating agency in the development of the second draft of the *Hanford Site Solid Waste Environmental Impact Statement (EIS)*. In that letter, U. S. Department of Energy (USDOE) indicates that it intends to release the second draft in March 2003. The Yakama Nation believes that USDOE's proposal to dispose of immobilized low activity waste at Hanford is inconsistent with requirements in the Nuclear Waste Policy Act. Because of this issue and others, the Yakama Nation respectfully declines to be a cooperating agency in the preparation of the EIS.

The USDOE has a fiduciary trust responsibility to consult the Yakama Nation prior to taking an action that will impact the Yakama people and retained treaty resources and rights. The proposed actions identified in the draft EIS and anticipated changes highlighted in the January 23, 2003 letter will have long-term impacts to the Yakama people and treaty resources and rights. I request that USDOE provide a briefing to the Yakama Nation Environmental Restoration/Waste Management Program on the scope and proposed alternatives in the second draft.

The Yakama Nation ERWM program found the initial draft EIS to be environmentally unsatisfactory (considering that off-site waste may be disposed at Hanford and threaten the Columbia River) and inadequate because of the lack of waste stream characterization and omission of pre-1970 transuranic waste in its scope. Mr. Collins in his January 23, 2003 letter did not mention pre-1970 waste as an issue to be analyzed in the second draft. How will this waste stream be handled? Please provide us with the framework and timeline for retrieving and disposing of this waste off-site.

The Yakama Nation has concerns regarding the importation of off-site waste for Hanford disposal given the proximity of the Columbia River and its importance to populations

Post Office Box 151, Fort Road, Toppenish, WA 98948 (509) 865-5121

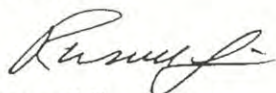
### Attachment 9 (contd)

downriver and to their health and the Yakama peoples'. Please let us know when consultation can begin on this matter. At issue is whether the Hanford Site should even be considered as a disposal site for any waste given that radiological and hazardous wastes located on the Central Plateau have reached the Columbia River via the ground water and threaten humans and aquatic receptors. To date, USDOE has been unsuccessful at preventing these contaminants from reaching the river. In August 2002, the EPA released the results of a fish study<sup>1</sup> that found the highest concentration of chemical contaminants in Columbia River fish to be in the Hanford Reach, posing up to a 1 in 50 cancer risk among tribal people. Based on this extraordinary risk, how can you assure us that additional waste disposed at the Site will not contribute to an increased risk to tribal members and aquatic organisms given the previously stated facts?

Consultation needs to be initiated with the Yakama Nation regarding what issues should be part of the National Environmental Policy Act analysis. Hopefully, our governments can reach a mutual agreement on the acceptability of actions consistent with federal and tribal laws and policies and the doctrine of Trust Responsibility. For the Yakama Nation decisions must protect the resources to which the Yakama Nation has specific aboriginal and Treaty reserved rights, protect the unique culture and worldview and enable continued practice of the tribal religion.

Given the significance of these issues, the Yakama Nation respectfully declines the offer to be a cooperating agency on the Hanford Site Solid Waste Program EIS. Please contact me in the near future to arrange a meeting to discuss these concerns. I may be reached at 509/452-2502.

Sincerely,



Russell Jim, Manager  
Environmental Restoration/Waste Management Program

Tom Fitzsimmons, Director, Washington Department of Ecology  
John Iani, Region X Administrator, USEPA  
Michael Collins, USDOE-RL

**RL COMMITMENT  
CONTROL  
MAR 03 2003  
RICHLAND  
OPERATIONS OFFICE**

---

<sup>1</sup> U.S. Environmental Protection Agency, Region X, Seattle, Washington, 98101, "Columbia River Basin Fish Contaminant Survey, 1996-1998, EPA 910-R-02-006, July 2002



## Attachment 9 (contd)

### YAKAMA NATION ERWM PROGRAM Specific comments on the draft Solid Waste Program EIS

- 1). The purpose and need statement needs to include pre-1970 TRU waste because it was managed as LLW before the definition of TRU was developed in 1970 and since solid LLW is already part of the proposed action.
- 2). Existing conditions at the low-level burial grounds have been ignored in the analysis. Two prime examples of this are; leaks under the burial grounds, (USDOE) presentation material) and subsidence (collapse of the surface of the burial grounds).
- 3). The pre-1970 TRU waste is being ignored and moved into other DOE-EM categories through a process that violates the federal cleanup agreement currently in existence.
- 4). Previous studies conducted for the USDOE indicate that high-level waste has been disposed of in the low-level burial grounds, and this omission is of serious concern.
- 5). The total inventory buried in the low-level burial grounds needs to be defined and presented in order to establish a factual basis for any decision made in this NEPA Under the alternatives, neither a liner is mentioned in the construction of the new LLBG trenches nor an analysis of risk performed for the life of the contaminants that would be placed in the trenches beyond the year 2046.analysis.
- 6). Any new trenches must contain liners even if the law does not require one. This would assist in preventing the movement of waste to the vadose zone/ ground water during the period that these contaminants pose a threat to the environment and human health.
- 7). A borrow site has been identified south of highway 240 on the Arid Lands Ecology Reserve. Full use of this area would result in the destruction of 926 hectares (2287 acres) of shrub\*steppe habitat. In addition, the proposed borrow site would impact cultural resources, aesthetic views, e.g. vision quests from sacred religious sites atop Rattlesnake and Gable Mountain, pose transportation hazards along highway 240and impact the Hanford Reach National Monument since the project abuts the National Monument boundary. USDOE anticipates only impacting 81 hectares (200 acres) for capping material. This appears to be the lower bounding limit since the soil/basalt volume calculations are based on construction of a modified RCRA C barrier, which requires less material than a Hanford barrier. It also does not include the cumulative needs from other projects that will require geological resources from this site.

The Yakama Nation has never been consulted by USDOE-RL on the location of this borrow site which will have significant adverse impacts on the resources mentioned in the previous paragraph. The Yakama Nation was not consulted on the *Use of Existing Borrow Areas*, DOE/EA-1403 (EA) October 2001 nor consulted on the development of the *Industrial Mineral Resources Management Plan and Aesthetic and Visual Resources Management Plan*, which requires a NEPA analysis. From a cursory review of DOE/EA-1403, we found major deficiencies in the NEPA analysis that should have led USDOE-



## Attachment 9 (contd)

RL to a determination to prepare an environmental impact statement. In addition, the EA failed to fully bound the impacts for geologic materials needed for capping material as document on page 1.24 of this EIS where USDOE states, “Although the total quantities of material necessary for final closure of the 200 LLBGs were not included in this EA [referring to DOE/EA-1403, October 2001] the locations evaluated included likely sources for these materials for the foreseeable future”. Therefore, USDOE needs to perform another NEPA analysis (preferably an EIS) for capping material and other uses. USDOE will need to consult the Yakama Nation closely on this issue so that our governments may reach a mutual agreement on geologic source sites for barrier construction and other needs.

8). The cumulative impacts analysis fails to consider past, present and future impacts to the environment including contaminant load and ground water.

Multiple past projects have had an impact on the shrub steppe habitat along with natural/human induced events, such as, the 2000 range fire which destroyed all mitigation for these past projects. No contingency plans have been initiated for the loss of these mitigation projects since the fire. Under USDOE’s management, the quality of the Hanford Site’s biological and cultural resources continues to degrade. USDOE has a fiduciary trust responsibility to ensure the protection of Treaty reserved resources such as foods and medicinal plants. Therefore, corrective actions are required for impacts from this proposed action.

9). USDOE-RL identified resources, i.e. 178 ha (440 acres) of land, that will be declared Irreversible and Irrecoverable because of this proposed action. USDOE-RL has a fiduciary responsibility to the Yakama Nation and as part of that responsibility, USDOE needs to fully mitigate for impacts prior to declaring the resources I&I. The mitigation hierarchy, as defined under 40 CFR § 1508.20, includes compensation. USDOE-RL will need to compensate the Yakama Nation for the loss of this land, if the waste cannot be disposed of off-site, because the action is occurring on Yakama ceded land. The Yakama Nation has not agreed to the creation of a sacrifice zone. USDOE-RL needs to consult the Yakama Nation on this matter and come to a mutual agreement before issuance of the final document and Record of Decision.

10). This proposed action could potentially impact up to 133 hectares (329 acres) of land in the 200 Areas plus an additional 81 hectare (200 acres) at the borrow site. These impacts will occur on Yakama Nation ceded land and impact reserved Treaty resources and rights. Therefore, USDOE must include mitigation measures (avoid, minimize, rectify, and compensate) in the final document and record of decision. USDOE-RL needs to consult the Yakama Nation to cooperatively develop a formal agreement on appropriate mitigation measures for this proposed action before issuance of the final document and Record of Decision.

11). Under section 4.7.1, language needs to be inserted that recognizes the Hanford Site as wintering grounds for the Yakama people and that they fished, hunted and gathered roots and medicinal plants in the area.

**Attachment 9 (contd)**

12). Under section 6.13 Treaties, Statutes, and Policies Relating to Native Americans, USDOE-RL asserts that they interact and consult regularly and directly with the three federally recognized tribes. No government-to-government consultation has occurred between the Yakama Nation and the Secretary of Energy on this proposed action.