



ERCOT Concept Paper on Distributed Energy Resources in the ERCOT Region

Submitted to the Distributed Resource Energy & Ancillaries
Market (DREAM) Task Force on August 19, 2015.

Document Revisions

| Date | Version | Description | Author(s) |
|-----------|---------|--|-------------|
| 8/18/2015 | 1.0 | Initial draft for DREAM TF review/discussion | ERCOT Staff |

Table of Contents

| | | |
|-------|---|----|
| 1 | Executive Summary | 5 |
| 2 | Introduction | 8 |
| 3 | Other Reference Materials..... | 12 |
| 4 | Definitions and Citations | 13 |
| 4.1 | Public Utility Regulatory Act (PURA)..... | 13 |
| 4.2 | Public Utility Commission Rules | 13 |
| 4.3 | ERCOT Definitions and Citations..... | 14 |
| 4.4 | Examples of Other Definitions of DER..... | 17 |
| 4.5 | Other Current ERCOT Requirements..... | 18 |
| 4.6 | Draft ERCOT DER Definition | 18 |
| 5 | DER Modelling and Data Requirements | 19 |
| 5.1 | Background..... | 19 |
| 5.2 | DER Impacts on Grid Reliability | 20 |
| 5.3 | Future Data Needs | 22 |
| 5.3.1 | Background..... | 22 |
| 5.3.2 | Data Submitted to ERCOT by TDSPs | 23 |
| 5.3.3 | Interim or Transition Phase..... | 25 |
| 5.3.4 | Distribution-Level Switching Implications..... | 26 |
| 5.3.5 | DER Heavy Settlement Point Issues..... | 26 |
| 5.3.6 | DER Heavy Outage Reporting | 27 |
| 5.3.7 | Data Aggregation by ERCOT and Public Posting..... | 27 |
| 5.3.8 | Potential New Requirements for Profile Codes and Resource IDs | 27 |
| 6 | Forecasting Tools | 29 |
| 6.1 | Background..... | 29 |
| 6.2 | Future Need for Distributed Solar Forecasting Tool | 29 |
| 7 | Interconnection Standards..... | 31 |
| 7.1 | Background..... | 31 |
| 7.2 | Benefits of Consistency across TDSPs..... | 31 |
| 8 | DER Market Options..... | 33 |
| 8.1 | Background..... | 33 |
| 8.2 | DER Minimal | 34 |
| 8.2.1 | Background | 34 |
| 8.3 | DER Light | 36 |
| 8.3.1 | Background | 36 |
| 8.3.2 | New Operational Requirements | 37 |
| 8.4 | DER Heavy | 39 |
| 8.4.1 | Background | 39 |
| 8.4.2 | New Operational Requirements | 41 |
| 8.5 | Other Market Implications for DER Heavy | 43 |
| 8.6 | DER Heavy with Demand Response | 43 |
| 9 | Metering Requirements | 44 |
| 9.1 | Background..... | 44 |
| 9.2 | Metering Configurations relative to DER Participation | 45 |
| 10 | Settlement Mechanisms..... | 47 |
| 10.1 | Background..... | 47 |
| 10.2 | DER Light/DER Heavy Settlement | 48 |
| 10.3 | Wholesale Storage Load Treatment for Distribution-connected Storage | 48 |
| 11 | Compliance Issues..... | 50 |

11.1 Background50

11.2 Compliance Issues for DER Light51

11.3 Compliance Issues for DER Heavy52

12 Non-Opt-In Entity (NOIE)-Specific Issues 53

12.1 Background53

12.2 NOIE TDSP Static Data Submission for DERs54

12.3 NOIE Meter Data Submission Processes for DER Light and DER Heavy55

12.4 NOIE DER Light and DER Heavy Metering55

12.5 Competitive QSE Participation in NOIE Territories56

13 Next Steps 57

Appendix A – Distributed Generation Profile Segment Assignment 58

1 Executive Summary

Electric systems and markets worldwide are dealing with dramatic change, and a major focus of the future will be on Distributed Energy Resources (DERs). This concept paper is intended to serve as a catalyst for development of new Protocols and other market rules affecting DERs in the ERCOT region and ERCOT wholesale markets, centered around two primary goals:

- Collection of data that ERCOT anticipates it will need, as the Independent System Operator (ISO) for the region, to ensure grid reliability as DER penetration increases in the grid of the future; and
- Development of a market framework that can better accommodate DERs and enable effective, efficient market participation.

This document contains the following recommendations:

Collection of DER-related data: This includes:

- 1) More detailed collection of static DER data from Transmission & Distribution Service Providers (TDSPs), in order to support various ERCOT grid reliability functions. Mapping of all DER sites to the appropriate modeled transmission loads on the ERCOT Common Information Model (CIM) will eventually be necessary to support effective reliability studies. Because TDSPs do not currently have processes in place to map DERs to CIM Loads, ERCOT proposes a transition phase in which TDSPs provide the mapping for all DERs to the appropriate transmission substation. However, mapping DERs to CIM Loads — via a process involving the Resource Entity, the TDSP and ERCOT — will be mandatory in the near term for settlement of DERs opting to be settled at a local (Nodal) energy price.
- 2) More frequent and detailed compilation and public posting by ERCOT of appropriate and non-confidential DER data, to assist operators, planners, and market participants in their decision-making processes.

New settlement options for DERs: This paper contemplates three categories of DER participation/settlement in the ERCOT markets:

- 1) DER Minimal, which would be settled at Load Zone Settlement Point Prices (LZ SPPs), essentially unchanged from current practice;
- 2) DER Light (either single site or aggregations), which would participate passively in the energy market while settled at Nodal prices via mapping of the DER location(s) to their appropriate CIM Load point(s); and

- 3) DER Heavy (either single site or aggregations), which would participate actively in the energy and Ancillary Services markets while settled at Nodal prices via mapping of the DER location(s) to their appropriate CIM Load point(s). In many respects, DER Heavy would be treated similarly to Generation Resources in the current market construct. A key feature of a DER Heavy is the assignment of a Logical Resource Node Settlement Point, and a Settlement Point on the transmission grid.

Treatment of Storage: Storage devices in a DER Light or DER Heavy seeking to receive Wholesale Storage Load (WSL) treatment will need to have well-defined metering configurations so that the electrical energy used to charge the storage device (settled at a Nodal price) can be measured separately from native and auxiliary Load (settled at the LZ SPP). The concepts presented in this document assume that WSL treatment for both DER Light and DER Heavy would be allowed under PUC Subst. Rule §25.501(m),¹ assuming metering requirements are met.

Treatment of Demand Response: Public Utility Commission (PUC) of Texas Substantive Rule §25.501 (h) requires Load to be settled at LZ SPPs. Absent a change or clarification to the Rule, this concept document assumes that demand response (DR) cannot be part of the performance of a DER Heavy or DER Light being settled at a Nodal price.

New metering configurations: ERCOT's proposal would not require any metering changes, unless DER's Resource Entity chooses to seek DER Light or DER Heavy status in order to attain Nodal pricing. In those cases, in order to maintain compliance with the aforementioned Rule, DERs Light and Heavy would require a type of metering configuration not currently in place in many ERCOT TDSP footprints, including the investor-owned TDSP service territories. Dual metering — separate measurement of gross generation and gross native Load — at DER Light and DER Heavy sites will be necessary to ensure that Load at the same Service Delivery Point continues to be settled at the LZ SPP while the on-site generation is settled at the Nodal price. This dual metering concept will likely require clarification by the PUC that Subst. Rule §25.213, which requires TDSPs to offer customers a net metering option, does not prohibit a dual metering option as described in this paper.

Information exchanged between Resource Entities representing DERs Light and Heavy, and ERCOT: Similar to how distribution-connected Load Resources are mapped to CIM Loads today, Resource Entities will need to work with TDSPs and ERCOT to provide accurate mapping of DERs Light and Heavy to their appropriate CIM Loads.

¹ See citation in Section 4.1.

Information exchanged between Qualified Scheduling Entities (QSEs) representing DERs and ERCOT: In order to support market participation by DERs Light and Heavy, QSEs representing these resources would need to provide ERCOT with appropriate data, including status and MW output in real-time or near real-time, via ICCP telemetry or another communications medium agreed upon by stakeholders. A DER Light, which otherwise would participate passively, should be required to respond to ERCOT instructions under emergency conditions. For DER Heavy, the information provided and the required response to ERCOT instructions — e.g., Base Points from Security Constrained Economic Dispatch (SCED) — should mimic the expected performance of conventional Resources.

As the ISO for its region, ERCOT has jurisdiction limited to the operation of the electric system at transmission (≥ 60 kV) voltage. Responsibility for operation of the distribution grid resides with the Distribution Service Providers (DSPs). ERCOT does not propose to alter this structure; rather, ERCOT proposes only to enhance visibility into the distribution system for the ISO and market participants, and to create a market environment that provides appropriate market signals for DERs.

2 Introduction

Traditional ways of generating and delivering electricity to customers are transitioning to a new paradigm. The spotlight is shifting to the distribution system and Distributed Energy Resources (DERs) are poised to take center stage. By most accounts, the future of electricity will involve a much greater level of distribution voltage level connected generation, driven by declining costs of small-scale generation, especially renewables, and the rise of new technologies such as distribution-level storage devices. Markets and grid operations are finding it necessary to adapt, some very quickly. Regions including Germany, Hawaii and California have seen rapid adoption of DERs, forcing them to build operational tools and market frameworks to accommodate DERs in a pressure environment.

Thus far, the influx of DERs has come more slowly in the ERCOT Region. Several factors are responsible for this, including relatively low-cost electricity and a regulatory environment that is different from other regions where DER adoption is promoted through policies such as feed-in tariffs. But the market forces behind DER growth are unmistakable, and all signs point to accelerated adoption worldwide, including Texas.

This has large implications not just for consumers, but also for the business functions of traditional generators, power marketers, Load-Serving Entities, TDSPs, and the ERCOT Independent System Operator (ISO).

A proposed ERCOT definition of Distributed Energy Resource (DER):

Generation or energy storage technology, or a combination of generation and/or energy storage technologies, that is interconnected at or below 60 kV, operates in parallel with the distribution system, and is capable of injecting electrical energy onto the distribution system.

Over time, DERs can bring numerous societal benefits to the electrical system, especially when deployed on distribution circuits close to load pockets. These benefits include:

- 1) Reduced transmission losses;
- 2) Reduced capital costs for high voltage interconnection facilities; and
- 3) Increased resiliency of distribution circuits to transmission failure events.

However, there are technical and structural barriers to realizing benefits of such a changed paradigm. These barriers include:

- 1) Lack of control mechanisms to manage the output of large numbers of DERs and avoid over/under-generation and potential damage to transmission/distribution facilities;

- 2) Lack of a robust monitoring infrastructure to know what impact these facilities are having on the electrical system in real-time;
- 3) Lack of consistent mechanisms, study processes and tariffs for interconnecting DER facilities across different TDSP service areas;
- 4) Lack of a mechanism to directly equate DER activity with reduced T&D costs, which could enhance the DER business case; and
- 5) Lack of a mechanism to incorporate DERs into Nodal price formation.

Under current ERCOT rules, distributed generators participate “passively” in the energy market. They effectively “chase” Load Zone Settlement Point Prices (LZ SPPs) via either “controlled passive response” from fossil fuel facilities or renewable facilities combined with storage; or via “uncontrolled passive response” from renewables that produce only when the sun is shining or the wind is blowing.

ERCOT is unable to deploy these resources, and the information ERCOT currently has regarding DER location, capacity, and real-time status will prove insufficient at some point in the future. DER penetration is already non-uniform across the grid, and this trend can be expected to continue, potentially creating impacts on transmission reliability studies.

Further, DER pricing at the Zonal level often dilutes incentives that could otherwise provide significant benefits to the grid and the market. Transmission-constrained areas such as the Rio Grande Valley and the Odessa oil fields are real-world examples of where strategically-located DERs could have positively impacted grid operations and mitigated local price spikes in recent months. DERs in those areas received no incentives to participate, because the prices they were exposed to were blunted by cheaper power elsewhere in the Load Zones.

The ERCOT Nodal market design launched in December 2010 has brought greater market efficiency and more appropriate price formation for all Resources. But as DER penetration increases and energy from the distribution system commands a greater share of the overall resource mix, the absence of Nodal pricing for DERs will result in a correspondingly greater share of generation in the market being settled zonally. Such a scenario could be viewed as constituting a retreat from the philosophy of the Nodal market design.

Enabling DERs to be settled on Nodal pricing could better align their decisions to generate power with grid conditions and thus enhance grid reliability. Higher Nodal prices are an indication of local scarcity, and could provide valuable signals to DERs in the area to generate if they are capable of doing so. In a similar way, lower Nodal prices related to local congestion would be an indication to reduce output, and such price signals are also valuable. To enable this, DER sites that choose to do so will need to be mapped to their appropriate transmission-level electrical bus(es), and settled at the Nodal price associated with that electrical bus (or some average of multiple buses).

This will require a new process of mapping DERs to their appropriate ERCOT CIM Loads, involving TDSPs, Resource Entities and ERCOT.

This concept paper assumes that exposure to Nodal prices should be optional for each DER; i.e., that the default settlement mechanism should be the status quo (Zonal). Policymakers and/or stakeholders will need to establish rules regarding how often a DER can change its settlement options between Nodal and Zonal. This can be expected to be an economic decision for the DER entity, as locational pricing will require the DER to meet additional requirements, including telemetry or some other type of real-time or near-real-time communication to the ISO (active power, status, etc.), and revenue-quality dual metering that measures DER gross output separate from the gross native Load behind the Service Delivery Point. This dual metering approach is a critical component of the framework enabling DERs to be settled at Nodal prices, but it potentially has broader implications for the ERCOT region.

Consider the current paradigm in ERCOT's competitive choice areas, where DER activity — including native Load and any exports to the grid — is measured by a single, bi-directional meter at the Service Delivery Point. In this case, the DER generation is offsetting native Load at the full *retail* rate, saving retail energy charges to the customer on a 1:1 basis per kWh and also reducing the customer's T&D charges proportionally. Over time, with significant DER penetration, the system-wide cost of transmission & distribution facilities are pushed to non-DER sites. (In other areas such as the Salt River Project utility in Arizona, this has prompted regulators to impose substantial monthly tariffs on DER premises — effectively, a DER surcharge — resulting in steep declines in DER installations.) Meanwhile, the Retail Electric Provider (REP) and its QSE serving the customer are responsible only for *net* Load and any associated charges based on Load Ratio Share, including Ancillary Service (AS) obligations, losses, and T&D charges. The REP/QSE hedges only for net load, and any demand charges (if applicable to the customer) are measured against net load. Assuming increases in the penetration of DERs with intermittent generation will result in increased system-wide AS requirements, assignments of AS obligations will also be borne inequitably by customers without DER.

Dual metering — measuring gross generation and gross native load — could provide an alternative to this spiral. Under dual metering, the QSE would be compensated at wholesale LMP for any exported generation, and all *gross* native Load, including Load served by the on-site DER, would be charged at the LZ SPP. The REP/QSE would be responsible for all costs (AS obligation, losses, T&D, etc.) associated with gross native Load; the REP/QSE would need to hedge against its gross native load; and demand charges (if applicable) would be assessed against gross native load. This paradigm could limit the scale of inequitable shifts in the DER cost burden across customers, and may not require changes to T&D tariffs as DER penetration increases.

The ability to separately meter gross native load and gross generation could enhance retail competition by opening up potential new business models for REPs. This could benefit end-use customers, especially if and when electricity prices trend upward.

3 Other Reference Materials

The following references may be helpful in developing the ERCOT approach to DERs:

California ISO DER Final Proposal

http://www.caiso.com/Documents/DraftFinalProposal_ExpandedMetering_TelemetryOptionsPhase2_DistributedEnergyResourceProvider.pdf

California Public Utilities Commission DG Interconnection Rule 21

<http://www.cpuc.ca.gov/PUC/energy/rule21.htm>

IEEE 1547 Standard for Interconnecting Distributed Resources with Electric Power Systems

http://grouper.ieee.org/groups/scc21/1547/1547_index.html

“A Review of Distributed Energy Resources” for the New York ISO, by DNV GL

(http://www.nyiso.com/public/webdocs/media_room/publications_presentations/Other_Reports/Other_Reports/A_Review_of_Distributed_Energy_Resources_September_2014.pdf)

Resources for New York Reforming the Energy Vision (REV)

<http://www3.dps.ny.gov/W/PSCWeb.nsf/All/CC4F2EFA3A23551585257DEA007DCFE2?OpenDocument>

4 Definitions and Citations

4.1 Public Utility Regulatory Act (PURA)

Sections § 39.914 and § 39.916 in the governing statute are relevant to this document:

- <https://www.puc.texas.gov/agency/rulesnlaws/statutes/Pura11.pdf>

4.2 Public Utility Commission Rules

See the following Substantive Rules:

- § 25.211 Interconnection of On-Site Distributed Generation
<http://www.puc.texas.gov/agency/rulesnlaws/subrules/electric/25.211/25.211.pdf>
- § 25.212 Technical Requirements for Interconnection and Parallel Operation of On-Site Distributed Generation
<http://www.puc.texas.gov/agency/rulesnlaws/subrules/electric/25.212/25.212.pdf>
- § 25.213 Metering for Distributed Renewable Generation and Certain Qualifying Facilities
<http://www.puc.texas.gov/agency/rulesnlaws/subrules/electric/25.213/25.213.pdf>
- § 25.217 Distributed Renewable Generation
<http://www.puc.texas.gov/agency/rulesnlaws/subrules/electric/25.217/25.217.pdf>
- § 25.501 Wholesale Market Design for the Electric Reliability Council of Texas
<http://www.puc.texas.gov/agency/rulesnlaws/subrules/electric/25.501/25.501.pdf>

The following excerpts from § 25.501 are of particular relevance to this document:

- (f) **Nodal energy prices for resources.** ERCOT shall use nodal energy prices for resources. Nodal energy prices for resources shall be the locational marginal prices, consistent with subsection (e) of this section, resulting from security-constrained, economic dispatch.
- ...
- (h) **Zonal energy prices for loads.** ERCOT shall use zonal energy prices for loads that consist of an aggregation of either the individual load node energy prices within each zone or the individual resource node energy prices within each zone. Individual load node or resource node energy prices shall be the locational marginal prices, consistent with subsection

(e) of this section, resulting from security-constrained, economic dispatch. ERCOT shall maintain stable zones and shall notify market participants in advance of zonal boundary changes in order that the market participants will have an appropriate amount of time to adjust to the changes.

...

(m) **Energy Storage.**

- (1) For a storage facility that has more than one delivery point, ERCOT shall net the impact of those delivery points on the ERCOT system for settlement purposes.
- (2) Wholesale storage occurs when electricity is used to charge a storage facility; the storage facility is separately metered from all other facilities including auxiliary facilities; and energy from the electricity is stored in the storage facility and subsequently re-generated and sold at wholesale as energy or ancillary services. Wholesale storage is wholesale load and ERCOT shall settle it accordingly, except that ERCOT shall settle wholesale storage using the nodal energy price at the electrical bus that connects the storage facility to the transmission system, or if the storage facility is connected at distribution voltage, the nodal price of the nearest electrical bus that connects to the transmission system. Wholesale storage is not subject to retail tariffs, rates, and charges or fees assessed in conjunction with the retail purchase of electricity. Wholesale storage shall not be subject to ERCOT charges and credits associated with ancillary service obligations or other load ratio share or per megawatt-hour based charges and allocations. The owner or operator of electric storage equipment or facilities shall not make purchases of electricity for storage during a system emergency declared by ERCOT unless ERCOT directs that such purchases occur.

4.3 ERCOT Definitions and Citations

Nodal Protocol Section 1.2, Functions of ERCOT

- (1) ERCOT is the Independent Organization certified by the Public Utility Commission of Texas (PUCT) for the ERCOT Region. The major functions of ERCOT, as the Independent Organization, are to:
 - (a) Ensure access to the ERCOT Transmission Grid and distribution systems for all buyers and sellers of electricity on nondiscriminatory terms;
 - (b) Ensure the reliability and adequacy of the ERCOT Transmission Grid;

- (c) Ensure that information relating to a Customer's choice of Retail Electric Provider (REP) in Texas is conveyed in a timely manner to the persons who need that information; and
- (d) Ensure that electricity production and delivery are accurately accounted for among the All-Inclusive Generation Resources and wholesale buyers and sellers, and Transmission Service Providers (TSPs) and Distribution Service Providers (DSPs), in the ERCOT Region.

Distribution System

That portion of an electric delivery system operating under 60 kV that provides electric service to Customers or Wholesale Customers.

Customer: An Entity that purchases electricity for its consumption

Wholesale Customer: A NOIE receiving service at wholesale points of delivery from an LSE other than itself

Entity: Any natural person, partnership, municipal corporation, cooperative corporation, association, governmental subdivision, or public or private organization.

Distributed Generation (DG)

An electrical generating facility located at a Customer's point of delivery (point of common coupling) ten megawatts (MW) or less and connected at a voltage less than or equal to 60 kilovolts (kV) which may be connected in parallel operation to the utility system.

Distributed Renewable Generation (DRG)

Electric generation with a capacity of not more than 2,000 kW provided by a renewable energy technology that is installed on a retail electric Customer's side of the meter.

Generation Resource

A generator capable of providing energy or Ancillary Service to the ERCOT System and is registered with ERCOT as a Generation Resource. The term "Generation Resource" used by itself in these Protocols does not include a Non-Modeled Generator.

Aggregate Generation Resource (AGR)

A Generation Resource that is an aggregation of non-wind generators, each of which is less than 10 MW in output, which share identical operational characteristics and are interconnected at the same POI and located behind the same Generator Step-Up (GSU) transformer (with a high-side voltage greater than 60 kV).

Intermittent Renewable Resource (IRR)

A Generation Resource that can only produce energy from variable, uncontrollable Resources, such as wind, solar, or run-of-the-river hydroelectricity.

Load

The amount of energy in MWh delivered at any specified point or points on a system.

Load Resource

A Load capable of providing Ancillary Service to the ERCOT System and/or energy in the form of Demand response and registered with ERCOT as a Load Resource.

Aggregate Load Resource (ALR)

A Load Resource that is an aggregation of individual metered sites, each of which has less than ten MW of Demand response capability and all of which are located within a single Load Zone.

Controllable Load Resource

A Load Resource capable of controllably reducing or increasing consumption under dispatch control by ERCOT.

Non-Modeled Generator

A generator that is:

- (a) Capable of providing net output of energy to the ERCOT System;
- (b) Ten MW or less in size; or greater than ten MW and registered with the PUCT according to P.U.C. SUBST. R. 25.109, Registration of Power Generation Companies and Self-Generators, as a self-generator; and
- (c) Registered with ERCOT as a Non-Modeled Generator, which means that the generator may not participate in the Ancillary Service or energy markets, RUC, or SCED.

Premise

A Service Delivery Point or combination of Service Delivery Points that is assigned a single ESI ID for Settlement and registration.

Service Delivery Point

The specific point on the system where electricity flows from the TSP or DSP to a Customer.

Wholesale Storage Load (WSL)

Energy that is separately metered from all other Facilities to charge a technology that is capable of storing energy and releasing that energy at a later time to generate electric energy. WSL includes losses for the energy conversion process that are captured by the WSL EPS Meter. WSL is limited to the following technologies: batteries, flywheels, compressed air energy storage, pumped hydro-electric power, electro chemical capacitors, and thermal energy storage associated with turbine inlet chilling.

[PIR003: ERCOT Protocol Interpretation of Wholesale Storage Load (WSL):²

On June 11, 2013, ERCOT issued a Protocol Interpretation on the definition of Wholesale Storage Load (WSL) – providing guidance on which facilities are eligible for Settlement treatment under WSL. See Market Notice M-A061113-1, Protocol Interpretation Request – Wholesale Storage Load, at http://www.ercot.com/mktrules/nprotocols/pir_process.html for full details of the Protocol Interpretation of WSL.

4.4 Examples of Other Definitions of DER

Electric Power Research Institute (EPRI): “....smaller power sources that can be aggregated to provide power necessary to meet regular demand.”

New York Independent System Operator (from DNV GL report): “....behind-the-meter power generation and storage resources typically located on an end-use customer’s premises and operated for the purpose of supplying all or a portion of the customer’s electric load.”

National Renewable Energy Laboratory (NREL): “....a variety of small, modular electricity-generating or storage technologies that are located close to the load they serve.”

² The ERCOT Protocols currently do not include a definition for storage resources, and there is no category for storage resources in the Network Operations Model (CIM). This concept paper does not recommend expanding the CIM to make it capable of recognizing and honoring the constraints and capabilities of storage facilities. However, ERCOT acknowledges that as storage devices begin to achieve significant penetration on the System, a modification to the CIM may be required.

4.5 Other Current ERCOT Requirements

Distributed Generation is required to register³ with ERCOT if its generating capacity exceeds the 1 MW registration threshold. This applies when the generation is expected to exceed the on-site Load and thus export to the grid, regardless of whether the DG unit is located in a competitive choice TDSP area or a NOIE area. Net energy exported from a Service Delivery Point associated with registered DG is accounted for in ERCOT Settlements via direct payment to the QSE representing the DG asset, paid at the LZ SPP.

For DG with capacity equal to or below 1 MW, registration with ERCOT is permitted but not required. Power exported to the grid from unregistered DG is accounted for in the load aggregation process for Settlements — effectively treated as “negative Load” where the QSE representing the co-located Load is credited via Real-time Energy Imbalance, also at the LZ SPP.

4.6 Draft ERCOT DER Definition

Distributed Energy Resource

A generation or energy storage technology, or combination of generation and/or energy storage technologies, that is interconnected at or below 60 kV, operates in parallel with the distribution system, and is capable of injecting electrical energy onto the distribution system.

³ The registration process for DG is a modified version of the Resource Asset Registration Form (RARF) required for Generation and Load Resources, with fewer parameters and data points required.

5 DER Modelling and Data Requirements

5.1 Background

Data Submitted to the PUC. Competitive choice TDSPs are required by PUC Subst. Rule 25.211 to submit annual reports (by March 31 of each year covering the prior calendar year) to the PUC, and the reports are available to the public on the PUC website. These reports include the following data:

- 1) Facility number;
- 2) Feeder number;
- 3) Capacity (kW);
- 4) Fuel type; and
- 5) Technology.

The reports include all DG installed in each competitive-choice TDSP footprint during the prior calendar year, while reporting the prior year installations separately. The 2014 reports may be accessed under PUC Project No. 44023.

Data provided to ERCOT. When a competitive-choice TDSP executes a DG interconnection agreement with a customer for an Advanced Metering System (AMS)-metered DG unit, the TDSP is required to submit a Profile type change to ERCOT, assigning the Electric Service Identifier (ESI ID) to a DG Load Profile type — for photovoltaic (PV), wind (WD) or other DG (DG). If the DG unit is metered with an Interval Data Recorder (IDR) Meter⁴, the TDSP establishes a Resource ID (RID) for the corresponding ESI ID at that site.

In competitive choice areas of ERCOT, unregistered DG kWh outflows (only that energy injected onto the grid) by DG units are submitted to ERCOT by the TDSP through the Texas SET retail transaction process, using either AMS interval data (LSE File) or a Non-IDR 867 TX SET transaction. ERCOT reports on unregistered DG greater than 50 kW, by Load Zone, on a quarterly basis. The Distributed Generation Profile Segment Assignment details may be viewed in Appendix A of this concept paper.

⁴ IDR Meters and AMS Meters both collect 15-minute interval energy consumption data for settlement, and both may be configured to provide bi-directional data if DG is present.

5.2 DER Impacts on Grid Reliability

Public Utility Commission of Texas Substantive Rule §25.361⁵ assigns the following responsibilities to ERCOT:

- (b) ERCOT shall perform the functions of an independent organization under the Public Utility Regulatory Act (PURA) §39.151 to ensure access to the transmission and distribution systems for all buyers and sellers of electricity on nondiscriminatory terms; ensure the reliability and adequacy of the regional electrical network; ensure that information relating to a customer's choice of retail electric provider is conveyed in a timely manner to the persons who need that information; and ensure that electricity production and delivery are accurately accounted for among the generators and wholesale buyers and sellers in the region. ERCOT shall:
 - (1) administer, on a daily basis, the operational and market functions of the ERCOT system, including procuring and deploying ancillary services, scheduling resources and loads, and managing transmission congestion, as set forth in this chapter, commission orders, and ERCOT rules;
 - (2) administer settlement and billing for services provided by ERCOT, including assessing creditworthiness of market participants and establishing and enforcing reasonable security requirements in relation to their responsibilities under ERCOT rules;
 - (3) serve as the single point of contact for the initiation of transmission services;
 - (4) maintain the reliability and security of the ERCOT region's electrical network, including the instantaneous balancing of ERCOT generation and load and monitoring the adequacy of resources to meet demand;
 - (5) provide for non-discriminatory access to the transmission system, consistent with this chapter, commission orders, and ERCOT rules;
 - (6) accept and supervise the processing of all requests for interconnection to the ERCOT transmission system from owners of new generating facilities;
 - (7) coordinate and schedule planned transmission facility outages;
 - (8) perform system screening security studies, with the assistance of affected TSPs;
 - (9) plan the ERCOT transmission system, in accordance with this section;
 - (10) establish and administer procedures for the registration of market participants;
 - (11) manage and operate the customer registration system;
 - (12) administer the renewable energy program, unless the commission designates a different person to administer the program;
 - (13) monitor generation planned outages;
 - (14) disseminate information relating to market operations, market prices, and the availability of services, in accordance with this chapter, commission orders, and the ERCOT rules;

⁵ <http://www.puc.texas.gov/agency/rulesnlaws/subrules/electric/25.361/25.361.pdf>

- (15) operate an electronic transmission information network; and
- (16) perform any additional duties required under this chapter, commission orders, and ERCOT rules.

To perform the duties specified in items (1), (4) (5) (6) (9) and (13) it is necessary for ERCOT to forecast the expected load of the ERCOT grid, forecast what generation resources will be available to serve this load, and administer functions to balance the two. ERCOT is charged with these duties over short, medium and long-term horizons.

ERCOT must also study the impact of contingencies on the electrical network, to assure reliability. To perform steady state analysis of the electrical grid and determine what elements are at risk of overload in the normal and post-contingency scenarios, ERCOT must create reasonable scenarios or power flow cases describing the points of injection and withdrawal of electricity from the grid. Very small additions of DER will not have a significant impact on these scenarios; however, larger or concentrated additions at individual substations could make these studies inaccurate and lead to failure to build sufficient facilities to maintain a reliable grid.

This need to build cases representing the behavior of the grid is probably even more sensitive for “dynamics” study cases. Power engineering “dynamics” studies typically conducted by ERCOT use arrays of differential equations describing the millisecond by millisecond changes in electrical output of resources, alternating with solutions to power flow equations to analyze time-dependent stability of the power grid. These studies are highly sensitive to topology changes and additional electrical injections. ERCOT expects that the results of these studies are likely to be very sensitive to DER injections.

Reliability Unit Commitment (RUC) as well as the Day-Ahead Market (DAM) and Congestion Revenue Rights (CRR) uses Load Distribution Factors to appropriately assign the Weather Zone Load Forecast (for RUC) or the Load Zone Bids (PTP Source/Sink for DAM and CRR, DAM Energy Only Offer/Bid) to individual CIM Loads. The use of these Load Distribution Factors to appropriately assign reasonable MW values to the CIM Loads for performing Power Flow and contingency analysis is impacted if DER injections at the CIM Load level are not properly accounted for (e.g. voltage violations could be misleading under contingency). These inaccuracies may be unacceptable as DER penetration becomes significant.

In addition, the Annual Load Data Request (ALDR) process needs to be revisited to ensure accurate and uniform reporting of DER data, so that DER penetration is accounted for consistently across all TDSPs, both competitive and NOIE.

For these reasons, ERCOT will eventually require additional and more granular information related to DERs, including the location of these sources and data describing their time-dependent interaction with the larger electric grid.

5.3 Future Data Needs

5.3.1 Background

The ERCOT Real-Time Market produces approximately 11,500 Locational Marginal Prices (LMPs) every five minutes, of which, approximately 4,000 LMPs correspond to the electrical buses associated with CIM Loads. The ERCOT Network Model Management System (NMMS) models the electric grid down to the high side of load-serving substation transformers. An ERCOT CIM Load is a modeling construct, determined by each TDSP, and modeled in the NMMS. Typically, an ERCOT CIM Load represents the load on an individual substation transformer. However, NMMS Load modeling is subject to TSP discretion and may be more or less discrete depending on both the load being modeled and the TSP practice. Substations with both NOIE Load and Competitive Load or with multiple NOIE Loads need to have those Loads modeled separately. Each CIM Load is connected to an Electrical Bus. Approximately half of all substations contain a single CIM Load; the others contain multiple CIM Loads, which may or may not be owned by the same TSP.

The following table provides a breakdown of CIM Loads per substation in the ERCOT CIM (as of the date of publication):

| CIM Loads per Substation | Number of Substations |
|---------------------------------|------------------------------|
| 1 | 1,151 |
| 2 | 853 |
| 3 | 171 |
| 4 | 66 |
| 5 | 15 |
| 6 | 8 |
| 7 | 5 |
| Total: | 2,269 |

The following diagram represents a typical configuration of a substation with multiple CIM Loads:

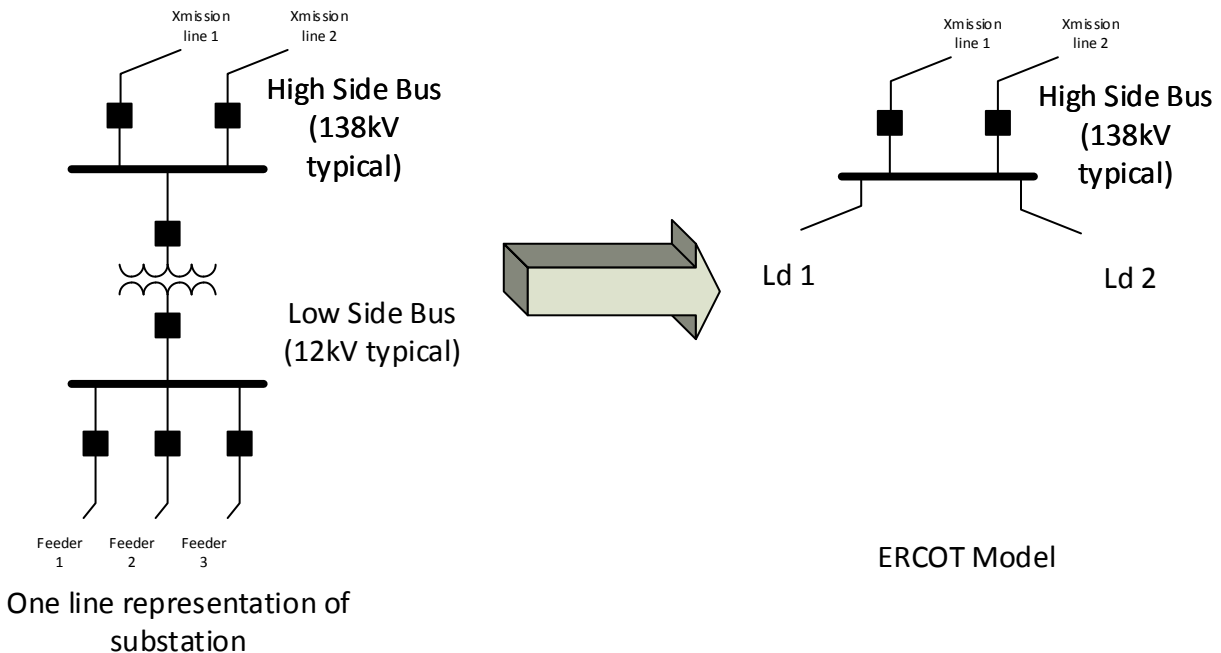

5.3.2 Data Submitted to ERCOT by TDSPs

The table below represents ERCOT’s initial recommendation for static data requirements to be submitted to ERCOT by competitive choice and NOIE TDSPs for DERs behind a revenue quality meter — either an ESI ID in a competitive choice area or a Unique Meter ID in a NOIE area. ERCOT encourages stakeholder discussions to develop consensus on appropriate additions and deletions to the proposed list.

The data in the table below includes data that is already submitted by competitive choice TDSPs when an ESI ID is assigned a Profile Code associated with DG. Rows are added to indicate the need for future data related to distributed storage and other DER combinations. It is assumed that the meter required is capable of recording energy consumption or generation on a 15 minute Settlement Interval (AMS or IDR or EPS) basis. In the table shown below, data related to Fuel Source, Stored Energy and the mapping of the DER to the ERCOT CIM Load(s) are not currently provided to ERCOT when there is a change to the Profile Code assignment. Also, ERCOT is proposing changes to the format of the current data provided to ERCOT to account for potential new DER technologies.

Table: Example of data from a DER behind a given ESI ID or Unique Meter ID.

| ESI ID or Unique Meter ID | Generation Technology (Type) | Interconnection Agreement Effective Date | Generation Capacity in KW DC or KW AC as applicable | Fuel Source | Stored Energy | Invertor Capacity in KW AC? (if applicable) | Inverter's published peak efficiency rating | ERCOT CIM Load(s) |
|---------------------------|------------------------------|--|---|-------------|---------------|---|---|-------------------|
| XYZ-1 | | | | | | | | LD-ABC |
| | PV | 1/1/2022 | 6 KW DC | Solar | | 7 KW | 95% | |
| | Storage | 9/15/2018 | 2 KW DC | Grid | 1 KWh | 2.5 KW | 90% | |
| XYZ-2 | | | | | | | | LD-DEF |
| | Fossil | 4/23/2012 | 3000 KW AC | Diesel | 50,000 gal | NA | NA | |
| | Wind | 10/9/2020 | 200 KW AC | Wind | | 210 KW | 97% | |
| | Integrated PV+Storage | 4/4/2017 | 20 KW DC | Solar | | 23 KW | 93% | |
| | | | 2 KW DC | Grid | 1 KWh | | | |
| XYZ-3 | Fuel Cell | 3/22/2016 | 2 KW DC | Nat. Gas | Piped | 22 KW | 98% | LD-ABC |

5.3.3 Interim or Transition Phase

ERCOT recommends that an interim or transition phase be put in place while DER penetration is relatively low, to allow competitive choice and NOIE TDSPs and ERCOT sufficient lead time to implement processes to support the data submissions that will eventually be required. During the transition phase, TDSPs will provide mapping of all DER installations to the ERCOT CIM Substation and not the CIM Load(s).

5.3.3.1 Interim Phase: Data submitted to ERCOT by TDSPs

| ESI ID or Unique Meter ID | Generation Technology (Type) | Interconnection Agreement Effective Date | Generation Capacity in KW DC or KW AC as applicable | Fuel Source | Stored Energy | Inverter Capacity in KW AC? (if applicable) | Inverter's published peak efficiency rating | ERCOT model Substation |
|---------------------------|------------------------------|--|---|-------------|---------------|---|---|------------------------|
| XYZ-1 | | | | | | | | ST-ABC |
| | PV | 1/1/2022 | 6 KW DC | Solar | | 7 KW | 95% | |
| | Storage | 9/15/2018 | 2 KW DC | Grid | 1 KWh | 2.5 KW | 90% | |
| XYZ-2 | | | | | | | | ST-DEF |
| | Fossil | 4/23/2012 | 3000 KW AC | Diesel | 50,000 gal | NA | NA | |
| | Wind | 10/9/2020 | 200 KW AC | Wind | | 210 KW | 97% | |
| | Integrated PV+Storage | 4/4/2017 | 20 KW DC | Solar | | 23 KW | 93% | |
| | | | 2 KW DC | Grid | 1 KWh | | | |
| XYZ-3 | Fuel Cell | 3/22/2016 | 2 KW DC | Nat. Gas | Piped | 22 KW | 98% | ST-ABC |

5.3.3.2 Interim Phase: Data submitted to ERCOT by Resource Entities registering DER Light and DER Heavy

A Resource Entity registering a DER Light or DER Heavy would need to provide the following new data in addition to other existing data requirements for the DER. The Resource Entity would also be responsible for maintaining the validity of this submitted data to ERCOT on an ongoing basis. The list below summarizes the first cut of the proposed data required to be submitted to ERCOT by the Resource Entity when registering a DER Light or DER Heavy:

- 1) ESI ID(s) or Unique Meter ID(s) that comprise a DER Light or DER Heavy. (Either a single ESI ID or Unique Meter ID for a single-site DER, or a list of same in the case of an Aggregated DER.)
- 2) For each ESI ID or Unique Meter ID, mapping to the appropriate ERCOT CIM Load.
- 3) Affirmation by the Resource Entity that each of the ESI IDs or Unique Meter IDs does not serve any native ERCOT Load or storage auxiliary Load behind the meter. Energy used to charge storage at a facility that has qualified for WSL Treatment is the only Load allowed to be settled at a Nodal price.

Rules and procedures will need to be developed to validate the list of ESI IDs and Unique Meter IDs on an ongoing basis. The process will involve coordination between the TDSP, Resource Entity and ERCOT. Such a process could mimic the methodology already in place for maintenance of populations within Aggregate Load Resources⁶.

5.3.4 Distribution-Level Switching Implications

The mapping of DERs (Light and Heavy) to CIM Loads in order to enable Nodal pricing is assumed to be static — that is, a static relationship will be established by the DSP/TSP between a DER (or more likely, depending on the TDSP, the distribution feeder associated with the DER) and its CIM Load(s) (typically 1:1 mapping). Distribution system facilities are primarily radial and are therefore subject to switching by the DSP in order to allow for necessary maintenance. At any given time, a small percentage — typically less than 5% — of a distribution system's Load will be switched to different feeders for this purpose. This could result in inappropriate Nodal price signals being provided to DERs Light and Heavy. However, given the technological challenges and associated expense of creating a system that permits dynamic switching of distribution feeders (or DERs) to CIM Loads, a certain level of inaccuracy in price formation may be tolerable at relatively low DER penetration levels. To ensure modeling accuracy as DER penetration increases, this issue should be revisited periodically by stakeholders and if required, analyze and develop enhancements to the mapping of DERs to applicable CIM Loads.

5.3.5 DER Heavy Settlement Point Issues

The DER Heavy concept is envisioned to be similar to a Combined Cycle Resource, which has a Logical Resource Node (based on mapping to appropriate transmission-level electrical buses) at which Resource-specific Three-Part Offers are settled. (Ancillary Service Offer settlement does not require a Settlement Point). In order to facilitate hedging — Congestion Revenue Rights (CRRs), Point-to-Point Options and

⁶ See Other Binding Document entitled "Requirements for Aggregate Load Resource Participation in the ERCOT Markets," at this link: <http://www.ercot.com/mktrules/obd/obdlist>

Obligations (PTPs), and Day-Ahead Market (DAM) energy-only Offers and Bids — a Settlement Point or Settlement Points will need to be established and modeled on the transmission grid, separate from the DER Heavy's Logical Resource Node. Development of this concept will require rules for establishing the(se) Settlement Point(s), especially in the more complex case of an Aggregated DER Heavy. The electrical connectivity path from the DER to the ERCOT Transmission System is not included in the ERCOT CIM.

5.3.6 DER Heavy Outage Reporting

Similar to requirements for Generation and Load Resources, the QSE representing a DER Heavy bears the responsibility for reporting outages that make the DER Heavy unavailable, for example due to planned maintenance outage of the DER. In the case of a DER Heavy, the QSE will also bear the responsibility of reporting DER unavailability due to outages in the distribution system. The Resource Entity for the DER Heavy must make arrangements or have provisions in its interconnection agreement/contract with the DSP to be provided timely information on distribution system outages that impact the operation of the DER Heavy.

5.3.7 Data Aggregation by ERCOT and Public Posting

Various stakeholders have voiced support for more frequent and more detailed reporting of data associated with interconnected DG in the ERCOT Region, and ERCOT generally agrees that current reporting mechanisms (as described in Section 5.1 above) will prove insufficient in the future. Eventually, ERCOT desires to collect all of the data described in the tables shown in this Section for each DER installation in the region, and to post publicly data that is permitted under Section 1 of the ERCOT Protocols. ERCOT acknowledges that TDSPs, NOIEs and other market participants may not currently have sufficient internal processes in place to support the long-term goal at this time, and commits to working with the market to develop a timeline for meeting these long-term goals for data collection and dissemination.

5.3.8 Potential New Requirements for Profile Codes and Resource IDs

Currently, an IDR-metered ESI ID in the distribution system with on-site DG does not have a directly applicable Profile Code (e.g., "IDRRQ-DG"). However, IDR-metered ESI IDs can be expected to have a Resource ID (RID) associated with any on-site DG, in order to enable the REP/QSE to receive the settlement benefits of any net generation as measured by the meter. RID information is accessible by ERCOT. Under current rules, an RID can be established only at IDR-Metered sites.

The existing list of Profile Codes and their associated data will eventually prove insufficient to accurately account for new DER technologies/configurations. ERCOT recommends that stakeholders consider whether new Profile Codes should be created for ESI IDs with DERs that include storage technologies, and combinations of DG and storage technologies. Additionally, ERCOT encourages stakeholders to consider allowing RIDs to be established at sites with AMS Metering.

6 Forecasting Tools

6.1 Background

ERCOT, anticipating a tripling of grid-scale solar installations over the next two years, is currently evaluating proposals for a utility-scale solar forecasting system. A decision to select the vendor is expected by the end of 2015.

6.2 Future Need for Distributed Solar Forecasting Tool

DER forecasting can be split into two separate categories: meteorological and non-meteorological. Technologies such as solar photovoltaic (PV) and wind turbines are highly dependent on meteorological conditions and as such would be forecasted based on weather conditions. However, other technologies such as combined heat and power (CHP) or cogeneration systems, microgrids, micro turbines, back-up generators and energy storage technologies typically operate to reduce overall demand at peak periods or respond during severe weather conditions to provide continuity of service for loads that they serve.

ERCOT has not yet initiated a project to select a forecasting tool for solar DERs. However, such a project is under active discussion at the ISO. For meteorological (solar PV and wind turbine Resources) DER forecasting, the information that would be necessary to forecast accurately would be to capture manufacturer information related to the nameplate design. Electrical characteristics are expected to be within 10 percent of measured values at Standard Test Conditions of: 1000 W/m², 25°C cell temperature and solar spectral irradiance per ASTM E 892 or irradiation of AM 1.5 spectrum. As Solar PV DER penetration increases, it may be necessary to know if the panels are fixed or if they are tracking, etc. in order to have a more accurate forecast of their output. The location of the DER would be used to develop a weather based forecast along with these other characteristics. Meter data from the output of solar PV and wind DERs will be necessary to validate and improve the accuracy of the forecasting tool. The approach would be to use the solar density for an area in order to represent the potential solar production. This would also apply for wind facilities on the distribution system. The final forecast would then be produced by using meteorological information and translate the solar/wind forecast into a solar and wind “expected” production contribution. After the fact, we would then compare the test facility meter data to the forecast and correct any inaccuracies through forecast model training.

For near term forecast between 24 and 168 hours ahead, the forecast tools are designed to provide a forecast that would be better than typical persistence forecast. Beyond a 168-hour window, persistence forecasts are considered to be the best approach. If weather models are developed for longer periods, then the persistence models may become obsolete but for now 168 ahead appears to be the break point for using and improving solar and wind forecast.

The non-meteorological DER forecast would be similar in scope to the meteorological forecast by having watts-per-area mapped in high concentration areas. However, in the case of these dispatchable types of resource they would be triggered by market mechanisms for peak shaving. High concentrations of non-dispatchable resources would also be forecasted based on historical response (such as a measured response during large storms that could be anticipated under those conditions should they return). Over the long term, estimates for non-meteorological DER would be based on their typical response during high load conditions.

The overall approach for both of these forecasts would be to offset the ERCOT load forecast. Each forecast is done separately and then summed together so that an overall demand forecast is produced which accounts for load and the DER impacts on load.

7 Interconnection Standards

7.1 Background

PUC Substantive Rule §25.211 (Interconnection of On-Site Distributed Generation)⁷, which applies to TDSPs in competitive choice areas of ERCOT, includes a pro forma Agreement for Interconnection and Parallel Operation, which is required to be executed between the DSP and the customer at the time of a DG installation⁸. The agreement primarily deals with legal issues including, among numerous others, ownership, right of access, and disconnection procedures. It also affirms the following:

“Customer agrees that it shall ensure that the Facilities are constructed in accordance with specifications equal to or greater than the greater of those provided by the National Electrical Safety Code, approved by the American National Standards Institute, and the National Electrical Code, approved by the National Fire Protection Association in effect at the time of construction”

The form also collects basic data about the DG unit, some of which is reported by the TSP/DSP to the Commission annually per Substantive Rule §25.211. The interconnection agreement clarifies roles and responsibilities, and ensures customer protection rules are followed.

The scope of the Rule and the agreement do not extend to collecting the type and amount of data that would provide the ISO and stakeholders with information needed for monitoring high levels of DER activity on the system, nor does it extend to enabling participation by DERs in the ERCOT markets as is contemplated in this concept paper.

7.2 Benefits of Consistency across TDSPs

Other regions that have already experienced high DER penetration have found it necessary to adopt a common set of interconnection requirements. This provides a level of consistency that could provide value to DER entities, TDSPs, and the ISO.

⁷ This Rule is currently subject to a Rulemaking proceeding at the PUC, under project 42532.

⁸ Rule §25.211 including the language in the interconnection agreement are currently under review in PUC Rulemaking Project No. 42352. See: http://interchange.puc.state.tx.us/WebApp/Interchange/application/dbapps/filings/pgControl.asp?TXT_UTILTY_TYPE=A&TXT_CNTRL_NO=42532&TXT_ITEM_MATCH=1&TXT_ITEM_NO=&TXT_N_UTILTY=&TXT_N_FILE_PARTY=&TXT_DOC_TYPE=ALL&TXT_D_FROM=&TXT_D_TO=&TXT_NEW=true

Germany, Hawaii, and California — all of which are managing rapid growth in DER penetration — have either adopted or are in the process of adopting a common set of technical requirements for distributed PV, particularly requirements for smart inverters for PV. Based on the experience of these regions, particularly including California's Rule 21 (see Section 3), requirements for a DER installation could include:

- 1) Two-way communication/control between DER and remote entity (TDSP, QSE if applicable);
- 2) Anti-Islanding Protection;
- 3) Low and High Voltage Ride-Through;
- 4) Low and High Frequency Ride-Through;
- 5) Dynamic Volt-Var Operation;
- 6) Ramp Rates;
- 7) Fixed Power Factor; and
- 8) Soft Start Reconnection.

ERCOT encourages stakeholders to consider whether a common set of DER interconnection requirements in the ERCOT Region could be adopted by competitive choice and NOIE DSPs, and whether the requirements would provide value to all stakeholders and grid operations.

8 DER Market Options

8.1 Background

To date, ERCOT settlements in the distribution system — both injections and withdrawals — are at the LZ SPP. Currently, any injection as measured at the settlement meter for a given 15-minute Settlement Interval is settled as “negative load treatment” at the LZ SPP, or the DER’s QSE is paid the applicable LZ SPP, depending on whether the DG is unregistered or registered, respectively. This approach is sufficient provided that the penetration of DERs is negligible in the big picture of price formation and grid reliability. However, if DER penetration trends accelerate, and policymakers and stakeholders agree that DERs should be incorporated into market mechanisms, then this approach should be revisited.

Transmission Congestion. ERCOT manages congestion in the modeled transmission network (≥ 60 kV). With significant penetration of DER within a Load Zone, congestion management on the transmission grid could benefit greatly if the DER were settled on prices that were in sync with their impact on congestion. If an “offline” DER is capable of generating energy to help relieve congestion in the network, a locational price signal (which could go significantly high) would provide the proper price incentive for the DER to produce as much energy as it can. The converse of high prices would also apply. If a DER producing energy is contributing to congestion in the ERCOT modeled transmission network, then an appropriate low (or negative) Nodal price signal could provide the right price incentive for the DER to curtail its generation.

This proposal for DER pricing mechanisms assumes that ERCOT will not model the distribution network. The proposal for DER pricing mechanisms addresses three categories of DER:

- 1) DER Minimal: Energy settled at the LZ SPP, with ESI IDs or Unique Meter IDs mapped to the applicable transmission Substation;
- 2) DER Light: Energy settled at a Nodal price associated with the applicable local electrical bus(es), with ESI IDs or Unique Meter IDs mapped to the appropriate CIM Load(s); and
- 3) DER Heavy: Energy settled at the applicable Settlement Point (a Logical Resource Node consisting of a combination of local electrical bus(es)), with ESI IDs or Unique Meter IDs are mapped to the appropriate CIM Load(s).

The table below summarizes the features of the three market options proposed for a DER:

| Features | DER Minimal | DER Light | DER Heavy |
|---|--|---|---|
| Energy Settled at: | Load Zone SPP | Price at Local electrical bus(es) | Logical Resource Node (price at Local electrical bus(es)) |
| Energy Market Participation | Self-responding | Self-responding | SCED-dispatched |
| Ancillary Service Market Participation | Not eligible | Not eligible | Eligible |
| Aggregation Allowed? | N/A | Yes | Yes |
| Metering Required | Single meter OK (15-minute revenue quality) at POI | Separate (dual) metering for Generation and native Load | Separate (dual) metering for Generation and native Load |
| Telemetry or telemetry-light to and from ERCOT | Not required | Real-time or near real-time with multiple attributes | Real-time or near real-time with multiple attributes |
| COP, Outage Schedule, Offers/Bids, etc. | N/A | Possible "light" version required | Required |
| CRR/PTP Implications | None | None | Yes |

8.2 DER Minimal

8.2.1 Background

The concept of DER Minimal is effectively what exists today — that is, a single meter at a single Service Delivery Point collects both net generation and net Load data for both the native Load and any DER generation behind the meter. Any storage device behind this type of configuration would be ineligible for WSL treatment. Both net consumption and net generation for a given 15-minute Settlement Interval are settled at the applicable LZ SPP. Distributed Generation at a DER Minimal could be either registered or unregistered; settlement methodologies would differ but in either case the ultimate settlement outcomes from the QSE's perspective would be the same.

An example of DER Minimal is a residence with a rooftop solar panel installation behind the settlement meter. In these cases in competitive choice areas, where bi-directional

metering is required, the only usage data available to ERCOT is the “net” generation to the grid (any kWh injected after serving the native Load) and the “net” Load served by the ERCOT grid (above what is served by the solar installation), on a per-interval basis. ERCOT does have access to other information via the Load Profile codes⁹, including fuel type and, nameplate capacity rating.

This diagram represents the DER Minimal configuration and metering Setup:

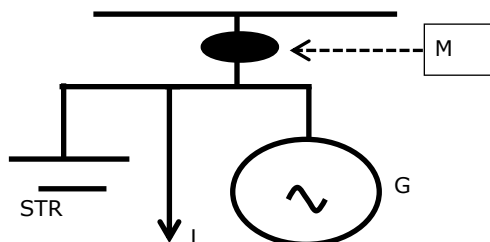

Participation as a DER Minimal would fall into two categories: those with registered Distributed Generation (DG) and those without registered DG. The following characteristics apply to DER Minimal:

- 1) If the DER Minimal is not formally registered with ERCOT as DG (i.e., its capacity is at or below the 1 MW registration threshold and its owner has elected not to register the DG with ERCOT), then its net energy injections in any 15 minute Settlement Interval, as measured by the “generation” channel of the settlement meter, are settled at the LZ SPP, benefitting its QSE in the form of “negative Load.” For this type of DER Minimal in a competitive choice area, the TDSP is required to submit a Profile Type change flagging this site as having onsite DG, to allow ERCOT to account for net generation as measured at the meter in Settlements.
- 2) If the DER Minimal is formally registered with ERCOT as Distributed Generation, then its QSE is paid directly for net energy injections in any 15-minute Settlement Interval, settled at the LZ SPP. For this type of DER Minimal, an RID is assigned for Settlement purposes.
- 3) In both cases, the QSE is effectively a price taker, and the DER Minimal does not actively participate in the ERCOT market.
- 4) ERCOT does not receive any Real-Time or near-real-time communication (e.g., telemetry) from the DER Minimal.
- 5) There are no requirements for submission of operational data such as COP, Bids/Offers, or Outage information for DER Minimal.

⁹ See ERCOT Load Profiling Guides, Appendix D:
<http://www.ercot.com/mktrules/guides/loadprofiling/current>

- 6) There are no ERCOT performance metrics or compliance requirements for DER Minimal.
- 7) DER Minimal cannot be dispatched by ERCOT.
- 8) The typical meter arrangement, as shown in the diagram, is such that the generation and/or storage cannot be registered with ERCOT as “market/reliability” Resources (capital “R”). They are either unregistered DG or registered with ERCOT as DG, or what is referred to as “Non-Modeled Generation.”

At this time ERCOT does not recommend any additional requirements for DER Minimal, apart from what is required as described in Section 5. However, stakeholders should consider the likelihood of eventual high penetration of DER Minimal — for example, 400,000 residential premises with Solar that are unregistered with ERCOT — and their potential impact on markets and reliability.

DERs could also impact congestion management at both the transmission and distribution levels. Stakeholders should consider whether uniform standards should be developed to enable TDSPs or ERCOT to have the ability to curtail their energy injections to the grid. Such a mechanism could be developed as part of a standard set of interconnection requirements; similar standards have already been adopted in Germany.

8.3 DER Light

8.3.1 Background

The concept of DER Light is to permit DERs to elect to have their generation settled at a Nodal price on a passive basis — meaning they would be exposed to Nodal prices and their associated incentives and disincentives, but not actively dispatched by ERCOT. The DER Light concept is new and will require significant stakeholder input and rules development.

DER Light without Storage, or with Storage that is not seeking WSL treatment: A site where DER Light is present would require metering that measures the site’s gross native Load and gross generation separately for each 15-minute Settlement Interval. The DER site’s gross native Load would be charged at the applicable LZ SPP, while the QSE would be paid for gross Generation at the applicable locational price.

DER Light that includes Storage seeking WSL treatment: If an on-site storage device is a component of the DER Light, in order for the storage device to receive WSL treatment, the metering configuration would need to measure the Load charging the storage device separately from other native and auxiliary Load. In such a case, the QSE would be paid for gross Generation at the applicable locational price, the energy used to charge the

storage device would be charged at the same applicable locational price, and other native and auxiliary Load would be charged at the applicable LZ SPP.

DER Light participation would require some real-time or near real-time communication of various data points to ERCOT, potentially via ICCP telemetry.

8.3.2 New Operational Requirements

ERCOT recommends that DER Light status should require interconnection, registration, qualification, telemetry, data submission and compliance requirements that are more rigorous than for DER Minimal, but less rigorous than for traditional Resources.

Metering Setup 1: DER Light with No Storage, or with Storage not seeking WSL Treatment

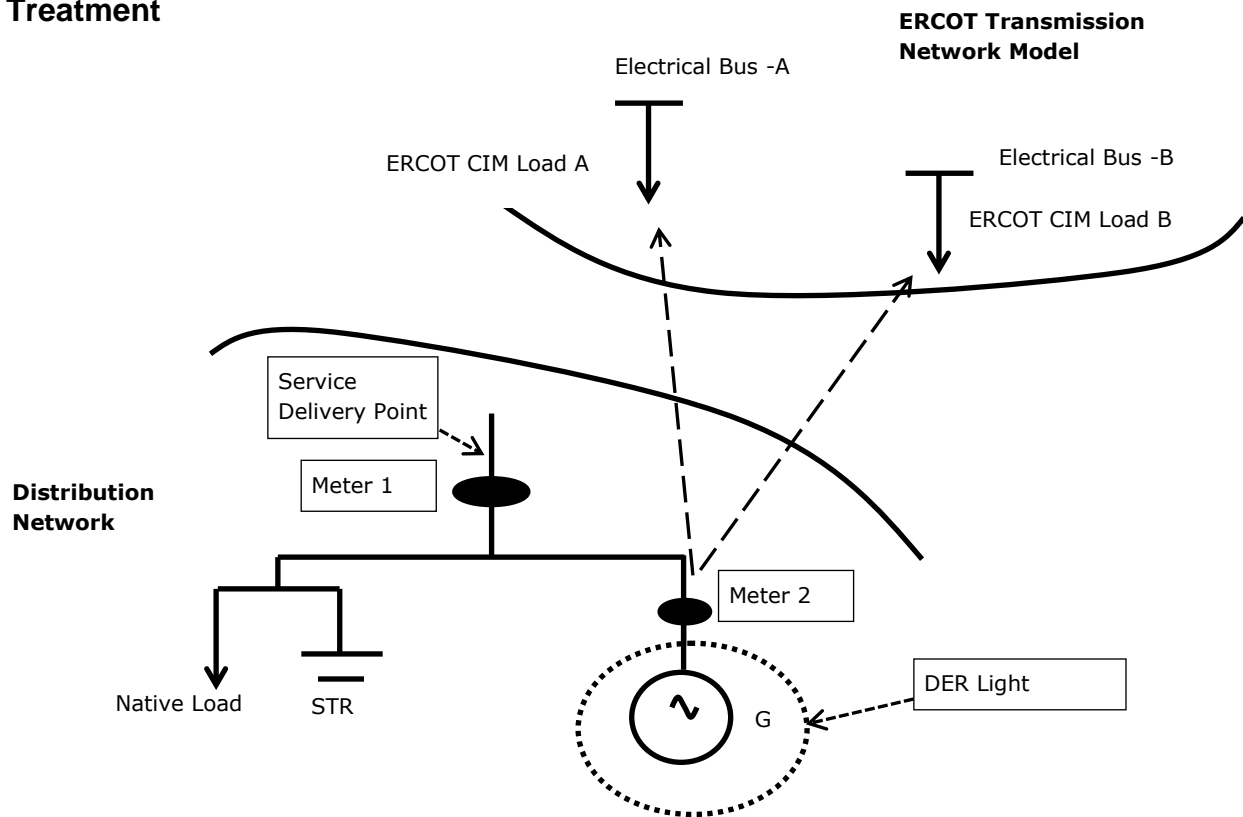

Metering Setup 2: DER Light with Storage seeking WSL treatment

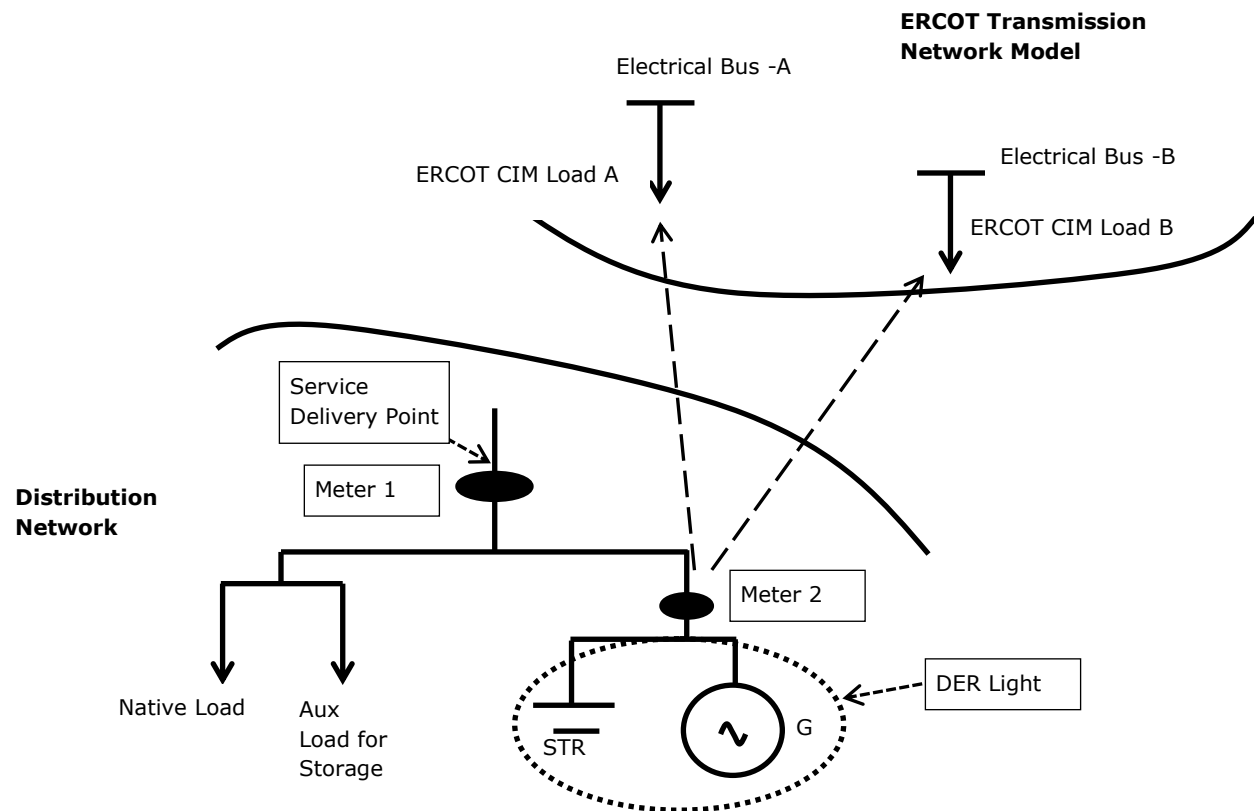

- 1) There is NO ERCOT load behind the DER meter (Meter 2 above). If there is a small station or auxiliary load then that station or auxiliary load must be SEPARATELY metered (Meter 1 above).
- 2) A DER Light would be a price taker and would not actively participate in the ERCOT energy or Ancillary Services markets. A DER Light would be paid a locational price for energy generated over a 15-minute Settlement Interval, as measured by the “generation” channel of the settlement meter (Meter 2 above).
- 3) The locational price for a DER Light shall not require establishing a Settlement Point. The purpose of this pricing point is solely to determine the price for energy injected in real-time by these Resources.
- 4) A DER Light could be single site or an aggregation, as long as the metering requirements are fulfilled.
- 5) A DER Light must have 15-minute settlement quality metering (AMS, or IDR).
- 6) ERCOT proposes to receive limited operational data via Real-Time or near-Real-Time telemetry from the DER Light, and may also receive a “light” version of a Current Operating Plan. A DER Light seeking WSL treatment will have a more

traditional Real-Time Telemetry requirement for the output (positive or negative) as measured at the meter (Meter 2 above). This is required in order to calculate the meter price used in Settlements.

- a) Stakeholder input will be required to determine additional DER Light requirements, such as the ability to commit a DER Light under Reliability Unit Commitment (RUC), with RUC's associated make-whole payment; and/or planned and forced outage information submitted to ERCOT.
- 7) The QSE representing the DER Light should be able to receive ERCOT instructions (potentially via ICCP, XML, or VDI/phone) during emergency conditions, and be able to have the DER respond to such instructions, either by curtailing generation or bringing generation online, depending on system conditions.
- 8) In order to ensure proper wholesale price formation, a SCED pricing run could be considered for any DER Light with non-zero marginal cost.
- 9) Real-Time or near-real-time data communication to ERCOT (potentially ICCP telemetry), measured at the meter point, should include at least the following:
 - a) Current Net MW output as measured at Meter 2 above
 - b) Status (Online, Offline-available, Out)
 - c) Net High Sustained Limit (HSL) as measured at Meter 2 above
- 10) ERCOT-to-QSE communications (via ICCP telemetry, XML, and/or phone/VDI) during emergency conditions, as determined by the ERCOT Operator, could have the ability to require a DER Light to:
 - a) Come online, similar to a RUC instruction; or
 - b) Curtail energy injections as measured at Meter 2 above

ERCOT recommends that stakeholders discuss the implications of this proposal in detail, including compliance implications and the possibility of "make-whole" compensation for DER Light emergency deployments.

8.4 DER Heavy

8.4.1 Background

The concept of DER Heavy is essentially the same as that of a traditional Resource, with the main difference being that it is connected at distribution voltage and the path from the resource to the ERCOT Transmission System is not in the ERCOT CIM. A DER Heavy would be eligible to participate actively in the ERCOT energy and Ancillary Services markets, and would have equivalent levels and metrics for registration,

qualification, performance, and compliance as traditional Resources, including but not limited to:

- 1) Submission of a Resource Asset Registration Form (could be the same as a Generation Resource, or a combination of Generation Resource/Controllable Load Resource, depending on whether storage is present);
- 2) Establishing a Resource Entity;
- 3) Establishing a QSE relationship;
- 4) Mapping to appropriate CIM Load(s) in the Network Model Management System;
- 5) Association with a new Resource Node for settlements;
- 6) Setup and certification of ICCP telemetry;
- 7) Qualification testing for SCED dispatch and any desired Ancillary Services; and
- 8) Qualification for WSL treatment, if applicable.

DER Heavy without Storage, or with Storage that is not seeking WSL treatment: A site where DER Heavy is present would require metering that measures the site's gross native Load and gross generation separately for each 15-minute Settlement Interval. The DER site's gross native Load would be charged at the applicable LZ SPP, while the QSE would be paid for gross Generation at the applicable locational price.

DER Heavy that includes Storage seeking WSL treatment: If an on-site storage device is a component of the DER Heavy, in order for the storage device to receive WSL treatment, the metering configuration would need to measure the Load charging the storage device separately from other native and auxiliary Load. In such a case, the QSE would be paid for gross Generation at the applicable locational price, the energy used to charge the storage device would be charged at the same applicable locational price, and other native and auxiliary Load would be charged at the applicable LZ SPP.

8.4.2 New Operational Requirements

A DER Heavy would participate in the ERCOT markets by providing data at an equivalent level of detail as a traditional Resource connected to the ERCOT transmission grid. The following DER Heavy configurations are contemplated:

Metering Setup 1: DER Heavy with No Storage, or with Storage not seeking WSL Treatment

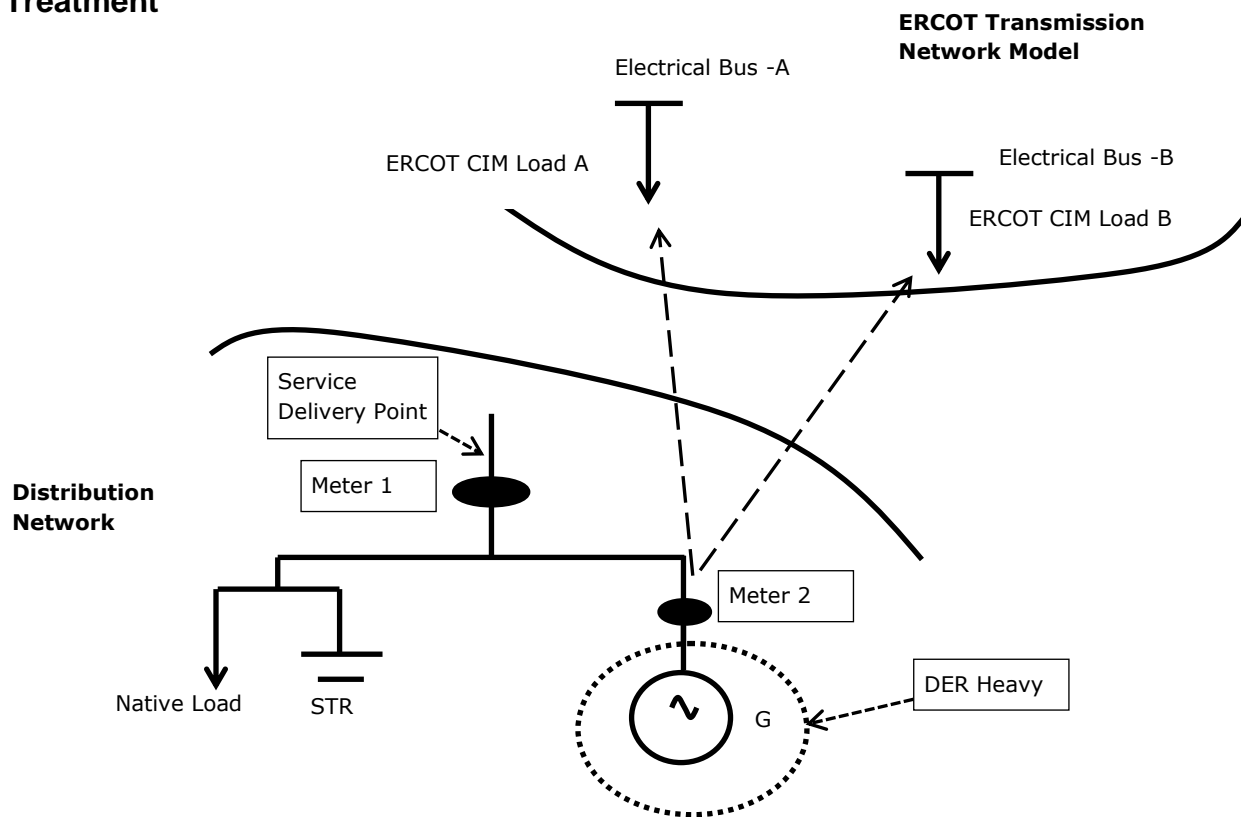

Metering Setup 2: DER Heavy with Storage seeking WSL Treatment

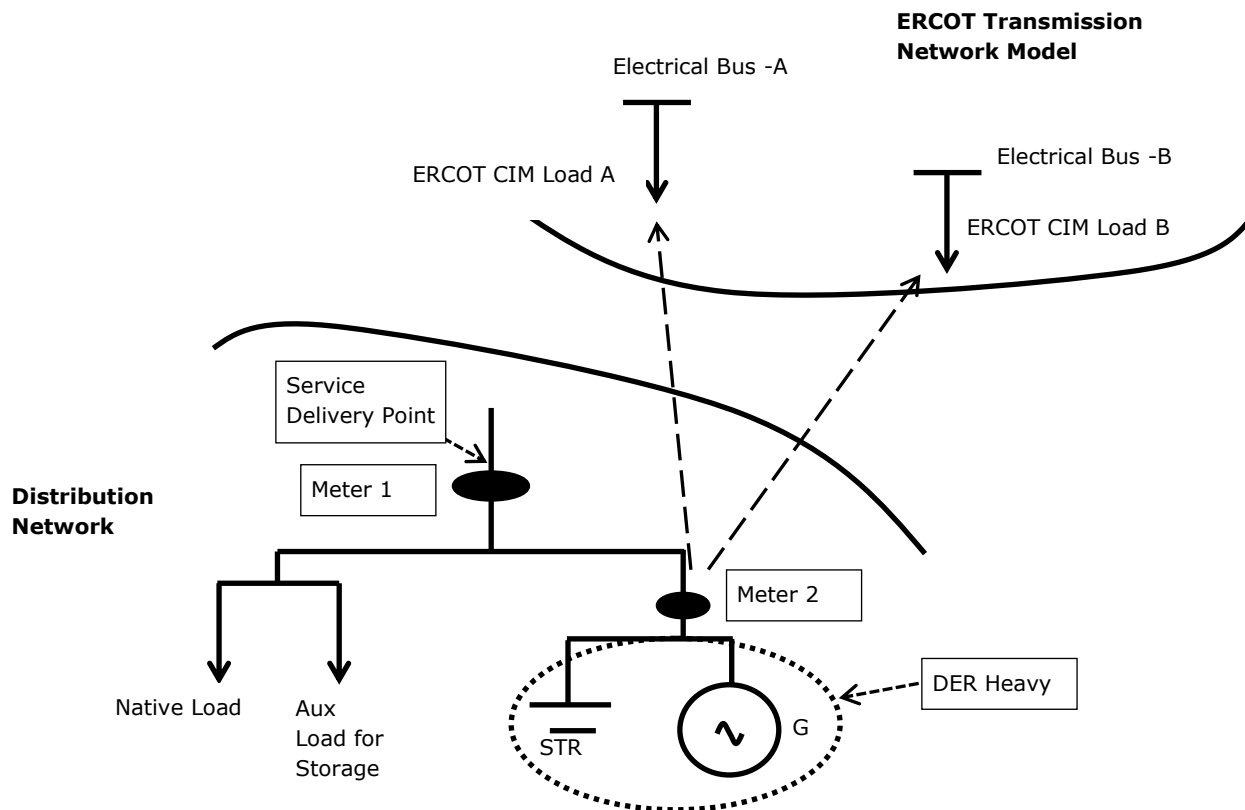

- 1) There is NO ERCOT load behind the DER meter (Meter 2 above). If there is a small station or aux load then that station or aux load must be SEPARATELY metered (Meter 1 above)
- 2) DER Heavy is qualified and registered with ERCOT.
- 3) DER Heavy is assigned a LOGICAL Resource Node (LRN) that is MAPPED to one or more electrical buses in the ERCOT network model. The LRN SCED LMP (nominally every 5 minutes) is the average of the individual electrical bus LMPs that make up the LRN. The 15 minute LRN Settlement Point Price is the energy weighted (Base Point) average of the SCED LMPs that was computed for a given 15 minute Settlement Interval.
- 4) For an aggregation, the LRN is DER Heavy capacity weighted for each electrical bus LMP that comprises the LRN. This LRN calculation methodology is similar to how combined-cycle Generation Resources are treated in Settlements today. (Aggregate Load Resources are not settled on LRNs but rather on LZ SPPs.)
- 5) Note that CRRs, PTPs, DAM energy-only Offers and Bids and QSE to QSE trades cannot be submitted at this LRN. The purpose of this LRN is solely for Resource Specific Offers.

- 6) DER Heavy can participate in energy market with an offer to sell energy with an Energy Offer Curve (EOC) or Three Part Offer (TPO).
- 7) For congestion management, this DER Heavy is assigned the applicable LRN Shift factor.
- 8) DER Heavy can offer to sell into AS market if qualified.
- 9) DER Heavy can be single site or an aggregation as long as the metering requirements are fulfilled (separate meter.)
- 10) MUST have 15 minute settlement quality AMI/IDR/EPS meter.
- 11) MUST have the telemetry for DER Heavy correspond to injection/withdrawal grid as measured at DER Heavy meter (Meter 2 above.)
- 12) Must adhere to all applicable rules (compliance TRE/NERC and market rules) for DER (e.g. COP, telemetry, Bids/Offers, outage etc.)

8.5 Other Market Implications for DER Heavy

For hedging purposes, as noted earlier DER Heavy Settlement Points (separate from the Logical Resource Node) on the ERCOT Transmission Model should be made available for CRRs, PTP Options and Obligations, and DAM energy-only Offers and Bids. Further stakeholder discussion will be required to develop procedures and rules for placement of these Settlement Points, especially for the more complex case of an Aggregated DER Heavy. An important note is that the Electrically Similar Settlement Point restrictions will need to be enhanced to prevent gaming.

8.6 DER Heavy with Demand Response

ERCOT at this time is not presenting a detailed proposal for the concept of DER Heavy with Zonal Settlement, a.k.a. “DER Heavy-Z.” This concept, which has been discussed briefly at the Emerging Technologies Working Group, could theoretically accommodate DERs in which demand response (DR) is contributing to the DER’s performance — for example, as part of a control system working in conjunction with generation and/or storage. This DER type is under active consideration in other regions, including some in which Nodal settlement for Loads is not disallowed by Rule as it is in the ERCOT Region. As noted earlier, ERCOT has not recommended that DERs Light and Heavy, which would be settled at a Nodal price, be permitted to include DR, absent a change or clarification of the requirement for Zonal settlement for Loads prescribed by PUC Subst. R. §25.501.

“DER Heavy-Z” market participation could in some ways mimic what ERCOT has developed for Load participation in SCED (NPRR 555) — that is, settlement at LZ SPPs and SCED dispatch based on Load Zone shift factors. ERCOT acknowledges that a prohibition on DR participation in DER Heavy could be interpreted as an unlevel playing

field for Load participation in the market, and is therefore open to further discussion of the “DER Heavy-Z” concept.

9 Metering Requirements

9.1 Background

For nearly all ESI IDs in the competitive choice areas, ERCOT receives 15-minute data representing net energy consumed or net energy injected into the transmission or distribution grid, as measured at the meter location. For ESI IDs with executed DG interconnection agreements, TDSPs are responsible for reporting bi-directional energy flows to ERCOT as separate channel reads — “generation/injection” channel and “load/consumption” channel.

Meter types currently in place in the competitive choice areas of ERCOT are detailed below (NOIE metering standards and requirements are unique to each NOIE):

| Meter Type | Description | Notes |
|-------------------------------------|---|---|
| Non-IDR | Load meter read by TDSP, measuring total kWh consumption over the billing period and, in the case of commercial accounts subject to demand charges, a peak demand value for the billing period. | A small fraction of the total number of ESI IDs are still metered this way. ESI IDs with Non-IDR metering are settled based on Load Profiles. This type of metering is disallowed for DERs Light and Heavy. |
| Advanced Metering System (AMS) | Meter read remotely by TDSP, collecting kWh data for each 15-minute ERCOT Settlement (clock) interval. May be configured as bi-directional for DERs (see below). | AMS meter data is uploaded within 48 hours via LSE file to ERCOT for settlement purposes. ESI IDs with AMS metering are settled on their 15-minute usage. |
| Interval Data Recorder (IDR) Meter | Meter read by TDSP, collecting kWh data for each 15-minute ERCOT Settlement (clock) interval, and potentially other values as agreed upon by TDSP and customer. IDR metering is required for customers with ≥ 700 kW of peak demand. | IDR meter data is typically submitted to ERCOT for settlement by the TDSPs via TX SET 867 transactions on a monthly basis. IDR Meters are also required for NOIE TDSP read boundary metering. |
| ERCOT Polled Settlement (EPS) Meter | Meter polled daily by ERCOT for use in settlement. | Required for Generation Resources in the ERCOT markets. |

Rules relevant to metering constitute Subchapter F of Chapter 25 of the PUCT Substantive Rules. TDSP requirements for DG metering in competitive choice areas are contained in Substantive Rules §25.211, §25.212 and §25.213.¹⁰

Currently, metering requirements for registered DG (required for all DG greater than 1 MW) in ERCOT are established by agreement between the TDSP and the Resource Entity representing the DG unit, and may be either EPS or IDR Meters.

9.2 Metering Configurations relative to DER Participation

Metering scenarios relevant to the DER discussion are described in the following table:

| Metering Type | Description | Notes |
|--------------------------|--|---|
| Unidirectional | Measures Load (consumption) only. | If DG is present, it is not accounted for in this type of metering. |
| Traditional Net Metering | Single-channel non-directional. Single data point representing net Load minus net on-site generation over a billing period, typically monthly (could be a negative number). | Disallowed in competitive choice areas of ERCOT by PUC Rule §25.213. |
| Bi-Directional | Two data points for each 15-minute interval: measures net in-flow to the Service Delivery Point (i.e., may be reduced by on-site DG), and net exports to the grid from the Service Delivery Point. | Required by PUC Rule §25.213 for competitive choice areas. Suitable for DER Minimal. |
| Dual Metering | Two bi-directional meters, two data points for each 15-minute interval, configured to measure gross native Load and gross generation behind the Service Delivery Point. This is a new concept in competitive choice areas. | Would enable DER Light and DER Heavy by allowing Load to be settled at LZ SPP and generation to be settled at Nodal price. Also could allow DSP to bill customer based on gross consumption (assuming permitted by tariff) and would enable LSE/REP to pay customer for gross generation. This metering scenario is in place for customers with DG in at least one NOIE territory in ERCOT. |

¹⁰ See <http://www.puc.texas.gov/agency/rulesnlaws/subrules/electric/Electric.aspx>

Existing DG settlement in the competitive choice areas is enabled by the bi-directional metering requirement. In order for generation data to be loaded by ERCOT for use in settlements (credit to be applied for the net generation recorded), the TDSP must activate the “generation” channel by assigning a WD, PV, or DG profile code.

An example of current DG settlement: assume a premise with rooftop solar experiences a fast-moving cloud, and for the first 7 minutes of a 15-minute Settlement Interval the site has net energy consumption (from the grid) of 2 kWh; then the cloud moves past the premise and for the next 8 minutes the site has net generation injection to the grid of 1 kWh. In this case the bi-directional meter will capture both the inflow and the outflow, and record 2 kWh of Load and 1 kWh of generation.

From the diagram below, for a given 15-minute Settlement Interval X, the two meters will each provide net outflow and inflow readings.

- 1) Meter 1 reads:
 - a) A for net outflows and,
 - b) B for net inflows
- 2) Meter 2 reads:
 - a) C for net outflows and,
 - b) D for net inflows
- 3) For a given 15-minute Settlement Interval X:
 - a) Energy consumption by Native Load +Aux Load = $B+C-(A+D)$
 - b) Energy generated by DER = C
 - c) Energy consumed for charging storage = D

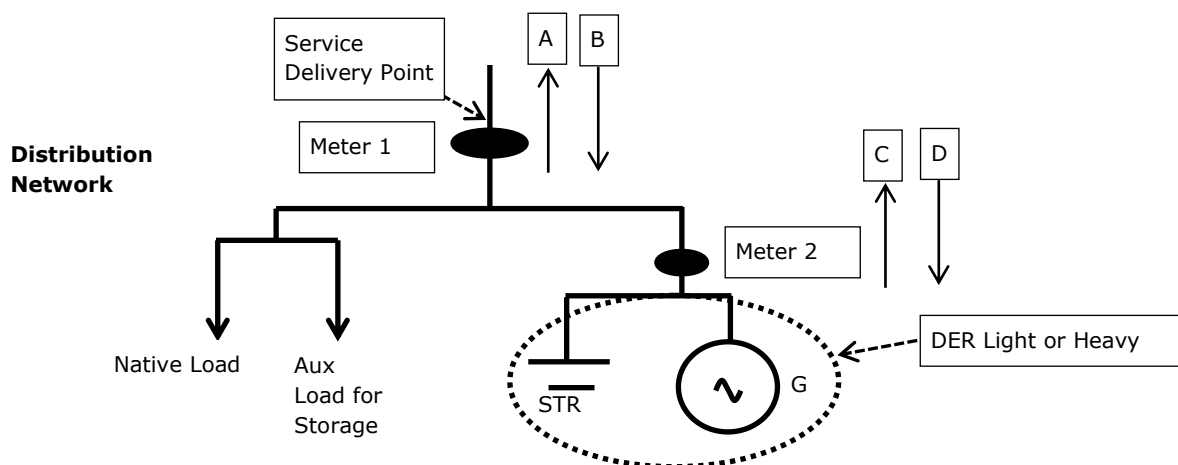

10 Settlement Mechanisms

10.1 Background

Currently, there are three configurations for DG Settlement in the competitive choice areas of ERCOT. These would continue to apply to DER Minimal.

- 1) The DG is unregistered. In this case, the DG capacity is equal to or less than 1 MW and there is a 1:1:1 relationship between the DG and its associated Load, and its REP, and the REP QSE. Any net energy outflow to the grid is captured by the generation channel of the bi-directional meter on a settlement interval basis. This energy is settled as “negative Load” — the QSE benefits from reduced Load, and is therefore effectively compensated at LZ SPP. (Meanwhile, the net Load is measured by the Load channel of the meter and the QSE is charged the LZ SPP for each interval.) Any energy payments to the customer must be covered in a bilateral contract between the customer and the REP.
- 2) The DG is registered and the generation is represented by the same QSE serving the Load. In this case, both a Resource ID and an ESI ID will be present at the Service Delivery Point, and there is a 1:1:1 relationship between the DG and its associated Load, and its REP, and the REP QSE. Any energy net outflow to the grid is captured by the generation channel of the bi-directional meter on a settlement interval basis, and the QSE is paid directly for the energy at the LZ SPP. (Meanwhile, the net Load is measured by the Load channel of the meter and the QSE is charged the LZ SPP for each interval.) Any energy payments to the customer must be covered in a bilateral contract between the customer and the REP/QSE.
- 3) The DG is registered and the generation is represented by a different QSE than the QSE serving the Load. In this case, both a Resource ID and an ESI ID will be present at the Service Delivery Point, there is a 1:1 relationship between the DG and its QSE (DG QSE), and a separate 1:1:1 relationship between the associated Load, its REP, and the REP QSE. Any net energy outflow to the grid is captured by the generation channel of the bi-directional meter on a settlement interval basis, and the DG QSE is paid directly for the energy at the LZ SPP. (Meanwhile, the net Load is measured by the Load channel of the meter and the REP QSE is charged the LZ SPP for each interval.) Any energy payments to the customer must be covered in a bilateral contract between the customer and the DG QSE.

10.2 DER Light/DER Heavy Settlement

A DER Light or Heavy would need to be registered with ERCOT as a new type of resource, different from current registered DG.

Under the proposed concepts for DER Light and DER Heavy, dual metering will be required in order to isolate gross generation from gross native Load. Absent a rule change or clarification to PUC Rule PUC Subst. R. §25.501 (h), ERCOT believes that Nodal settlement for a DER can only be rule-compliant if the generation and Load are metered and settled separately.

In the case of both DER Light and DER Heavy with either no storage devices, or with storage devices not seeking WSL treatment, ERCOT would pay the DG QSE (Resource ID) for energy injected to the grid at the Nodal price, and would charge the gross native Load (ESI ID) for its consumption at the LZ SPP.

10.3 Wholesale Storage Load Treatment for Distribution-connected Storage

Pursuant to PUC Subst. Rule 25.501 (m), which sets forth the rules relating to WSL, the Nodal price for energy that is consumed for purposes of charging a storage facility is calculated at the same location that the Nodal price paid for energy injected to the grid by the storage facility.¹¹

The PUC Rule contemplates equal treatment for the ability of storage facilities to be eligible to receive WSL treatment regardless of whether they are connected at transmission or distribution voltage. For a DER Light or Heavy that includes a storage device seeking WSL treatment, the following would apply:

- 1) The storage device would need to be qualified for WSL treatment, meaning that the DER is metered in such a way that the Load used to charge the storage device can be isolated from other native and auxiliary Load. Additional WSL qualification requirements may apply.
 - a) A DER Light or DER Heavy (either single site or aggregation) may include storage devices along with other generation technologies such as PV, all located behind the same bi-directional meter(s), which measure both the combined generation output and the Load used to charge the storage device(s). Such

¹¹ See full citation of 25.501 (m) in Section 4.1 of this document.

configurations could be eligible for WSL treatment, provided that all native and other auxiliary Load is separately metered.

- 2) Pursuant to the Rule, WSL is exempt from “retail tariffs, rates, and charges or fees assessed in conjunction with the retail purchase of electricity,” and is not subject to “ERCOT charges and credits associated with ancillary service obligations, or other load ratio share or per megawatt-hour based charges and allocations.” This includes the following charges:
 - a) Transmission and distribution (wires) charges;
 - b) Transmission and/or Distribution losses;
 - c) Ancillary Service charges; and
 - d) Any other normally uplifted charges or fees.

Under current ERCOT Protocols, Resources receiving WSL treatment are required to have an ERCOT Polled Settlement (EPS) meter. EPS Metering may be prohibitively expensive for distribution-level storage technologies. ERCOT encourages stakeholders to consider whether a Protocol change allowing AMS metering for DERs seeking WSL treatment is appropriate.

11 Compliance Issues

11.1 Background

Existing Generation Resources including Intermittent Renewable Resources, as well as Controllable Load Resources qualified to participate in SCED, are subject to numerous compliance metrics. Failure to meet the relevant performance criteria can lead to Protocol violations, compliance reports to the Texas Reliability Entity, and potential fines from the PUC Oversight and Enforcement Division. These compliance metrics include but are not limited to the following:

- 1) Base Point Deviation Charges¹²: These are charges assessed when the telemetered performance of a Generation Resource or Controllable Load Resource in SCED falls outside of certain defined tolerances. These charges are assigned to the QSE representing the Resource as part of the normal Settlement process.
- 2) Generation Resource Energy Deployment Performance (GREDP) and Controllable Load Resource Energy Deployment Performance (CLREDP)¹³. These are values computed monthly based on the cumulative SCED performance of Resources. Performance values that fall outside of prescribed parameters are subject to review by TAC, and subject to Protocol violation enforcement actions by ERCOT Compliance, the Texas Reliability Entity, and the PUC's Oversight and Enforcement Division.
- 3) Generation Resources are required to provide Primary Frequency Response and Reactive Power within prescribed parameters any time they are telemetering a status of "On."
- 4) Generation Resources are required to submit an Outage report to the ERCOT Outage Scheduler any time a unit is taken offline, either for planned maintenance or due to a forced outage.
- 5) The accuracy of Generation Resources' telemetry data is subject to validation and review by ERCOT Operations.

¹² See ERCOT Protocols Section 6.6.5.1.1, General Generation Resource and Controllable Load Resource Base Point Deviation Charge

¹³ See ERCOT Protocols Section 8.1.1.4.1, Regulation Service and Generation Resource/Controllable Load Resource Energy Deployment Performance

11.2 Compliance Issues for DER Light

DER Light participation in the market would be passive — that is, self-deployed and not under ERCOT dispatch control. Accordingly, the economic benefits or consequences of any actions undertaken by a DER Light in response to Nodal prices should be borne by the Resource and its QSE. For example, a DER Light that continues to inject power onto the system during a period when its Nodal price is below its marginal cost would bear the associated cost.

Beyond these direct economic incentives and consequences, ERCOT contemplates two areas where stakeholders should consider developing compliance metrics for DER Light:

- 1) *Validation of Telemetry or near-real-time data communication.* ERCOT recommends that DER Light be required to communicate certain data in real-time or near-real-time to ERCOT. The primary purpose of this data is to enable the Real-Time Market to better accommodate DER Light activity, primarily in the form of a separate SCED pricing run. Because a DER Light's passive response to Nodal prices would occur outside of SCED, it could lead to improper real-time price formation. The pricing run — envisioned to be similar to that implemented via NPRR 626 — could mitigate such distortion. For this reason, stakeholders should consider developing metrics for validating the real-time or near-real-time data being communicated to ERCOT. Such validation could rely on periodic comparisons of the telemetry (or near-real-time data communications) to physical meter reads at the Service Delivery Point(s).¹⁴
- 2) *Response to ERCOT Instructions during Emergency Conditions.* As discussed earlier, ERCOT recommends that stakeholders consider requiring a QSE representing a DER Light to be able to receive ERCOT instructions (potentially via ICCP, XML, or VDI/phone) during emergency conditions, and be able to have the DER respond to such instructions, either by curtailing generation or bringing generation online, depending on system conditions. If such a requirement is included in the eventual market rules related to DER Light participation, because the DER Light's action in response to the instruction could impact grid reliability, it will be necessary to prescribe compliance criteria and metrics around the DER Light's response to such an instruction.

¹⁴ A precedent for telemetry validation can be reviewed at the Other Binding Document entitled "Requirements for Aggregate Load Resource Participation in the ERCOT Markets," here: <http://www.ercot.com/services/programs/load/laar/index>

11.3 Compliance Issues for DER Heavy

DER Heavy participation in the markets would be active — that is, dispatched by ERCOT and similar in nearly every respect to participation by Resources in the Ancillary Services and Energy markets. Failure to perform by a DER Heavy would have impacts on grid reliability that are proportional to a performance failure by a Generation Resource or Load Resource. ERCOT recommends that performance criteria and compliance metrics should be developed for DER Heavy that closely mimic existing metrics for Resources — including Base Point Deviation Charges, GREDP/CLREDP performance scores, and other associated performance standards.

12 Non-Opt-In Entity (NOIE)-Specific Issues

12.1 Background

Non-Opt In Entities (NOIEs), consisting of municipally-owned utilities and electric cooperatives that have not opted into competitive choice, are subject to different treatment in ERCOT operations and markets. NOIEs are active participants in the ERCOT wholesale markets, and NOIE Transmission Service Providers (TSPs) are required to maintain their portion of the Network Operations Model just as competitive choice TDSPs must do. However, NOIEs differ from other TDSPs and market participants in various ways that will have impacts on DER data collection and market participation.

- 1) NOIEs are not subject to many PUC Rules, especially including rules pertaining to distributed generation interconnections and metering.
- 2) The only existing requirements for NOIEs to submit unregistered DG-related data to ERCOT are contained in the Commercial Operations Market Guide, Section 10.3.3¹⁵, as follows:
 - a) Within 30 days after the end of each quarter, ERCOT shall publish the Unregistered Distributed Generation Report on the Market Information System (MIS) Public area. This report shall include the aggregated data compiled for NOIE and competitive areas. This report at a minimum shall include the total unregistered DG above 50 kW and equal to or below the current DG registration threshold by the following groupings:
 - i) Technology Type;
 - (1) Renewable; or
 - (2) Non-renewable;
 - ii) Primary Fuel Type;
 - (1) Solar;
 - (2) Wind; or
 - (3) Other;
 - iii) Name Plate Rating MW; and

¹⁵ As of the initial publication date of this paper, this section of the COPMG is the subject of a Revision Request which could modify the reporting requirements.

- iv) Load Zone
- b) The report shall also include:
 - i) Annual kWh exported to the grid during the prior 12 months for each grouping; and
 - ii) New proposed DG threshold for registration as defined in Protocol Section 16.5, Registration of a Resource Entity.

NOIE premise-level meter data for unregistered DG is not submitted to ERCOT for settlements as it is for competitive choice Loads. NOIE settlements occur at the boundary meter level.

While the larger NOIEs that own and operate transmission facilities and Generation Resources (G&T NOIEs) are active in the ERCOT stakeholder process, most of the smaller NOIEs are Distribution Service Providers (DSPs) only and are not active at ERCOT.

The breakdown of NOIE TSPs and DSPs¹⁶ in ERCOT, as of July 2015, is as follows:

- 1) There are 14 NOIE TSPs who serve few if any end-use customers. The customers of these DSPs are wholesale customers, primarily NOIE DSPs; and
- 2) There are 105 NOIE DSPs, defined as DSPs that do not own transmission facilities beyond substation equipment. These are municipally-owned utilities and electric cooperatives that serve end-use customer Load. Many of these NOIE DSPs are small and rural, and do not regularly participate in the ERCOT stakeholder process.

12.2 NOIE TDSP Static Data Submission for DERs

NOIEs wanting to retain their current approach to DG would be allowed to do so. However, as described in Section 5, ERCOT proposes that NOIE TDSPs should be required to provide mapping of all DER sites to the appropriate transmission substation during the transition phase, and eventually to their appropriate CIM Loads. Resource Entities representing DERs Light and Heavy would work with NOIE TDSPs and ERCOT to map DER Light and Heavy sites to their appropriate CIM Load.

¹⁶ For reference, there are 10 investor-owned Transmission Service Providers, including six TSPs that also serve distribution-level Load (i.e., TDSPs). The other four TSPs own and operate transmission-level facilities only. There are a total of 300 registered Load-Serving entities in ERCOT; the LSEs that are not NOIEs are Competitive Retailers.

12.3 NOIE Meter Data Submission Processes for DER Light and DER Heavy

Premise-level NOIE Load is not settled at ERCOT, and NOIE TDSPs are not required to submit premise-level interval meter data to ERCOT. NOIEs are not required to participate in the Texas Standard Electronic Transaction (TX SET) system used for retail market transactions including IDR Meter data submittal in the competitive choice areas, and NOIEs similarly do not submit premise-level meter data to ERCOT via the AMS meter data submittal process.

Participation by DERs Light and Heavy in a NOIE territory will require a meter data submission process by the NOIE DSPs to ERCOT that replicates the data ERCOT receives from competitive choice areas. Such a process could be similar to the methodology developed by ERCOT as part of the enablement of Aggregate Load Resources to participate in SCED.¹⁷ Under this methodology, NOIEs would transfer encrypted meter data via internet to the ERCOT server which is consistent with North American Energy Standards Board (NAESB) standards. The submission process would require each NOIE DSP to become compliant with the transport mechanism and the server interface, but would not require TX SET compliance. This process would also need to take into account the need for SSAE16 audit controls/compliance for any meter data used in energy settlements.

12.4 NOIE DER Light and DER Heavy Metering

In order to support market participation by DERs Light and Heavy in NOIE territories, NOIEs would need to adopt metering policies and tariffs that support the contemplated DER configurations as described in prior sections:

- 1) DER Light or Heavy without storage, or with storage that is not seeking WSL treatment (dual metering, separating gross generation from gross Load); and
- 2) DER Light or Heavy with storage that is seeking WSL treatment (a metering configuration that isolates native and auxiliary Load from the Load charging the storage device, and separate metering for the generation).

Because NOIE premises are not assigned ESI IDs as they are in competitive choice areas, for DERs Light and Heavy the NOIE DSP should submit meter data using unique meter identifiers. These unique identification numbers should preferably be established

¹⁷ See the Other Binding Document entitled “Requirements for Aggregate Load Resource Participation in the ERCOT Markets,” at this link: <http://www.ercot.com/mktrules/obd/obdlist>

using ESI ID-style nomenclature, in which the NOIE TDSP Department of Energy (DOE) code comprises the first digits of the identifier. The unique meter identifier must remain constant in perpetuity at the Premise.

12.5 Competitive QSE Participation in NOIE Territories

ERCOT Protocols¹⁸ currently require QSEs offering competitive services in a NOIE service territory to first obtain written authorization from the NOIE and submit such authorization to ERCOT.

¹⁸ See Protocols Section 16.2.3, Remaining Steps for Qualified Scheduling Entity Registration

13

Next Steps

The concepts presented here are numerous and complex, and could take considerable time and effort to develop and implement. However, components of the proposal are capable of being implemented independently. ERCOT has already received several real-world inquiries related to DER Heavy interconnection and market participation. Therefore, ERCOT recommends that stakeholders in the DREAM TF focus initial attention on enablement of the DER Heavy concept.

Additionally, some issues may be out of scope for the ERCOT stakeholder process and may require action or clarification by the PUC. These may include but are not limited to the following:

- 1) Evaluate Customer Protection Rules to see if appropriate data related to DERs is being communicated on customer billing.
- 2) Clarify which party is responsible for paying for dual metering for DER Light and DER Heavy.
- 3) Determine whether TDSPs should own the responsibility for submitting all meter data to ERCOT from a DER Light or Heavy where dual metering is present, including data from the generation meter which may be “behind” the Service Delivery Point.

If the Commission determines that reading a meter behind the existing Service Delivery Point is out of a TDSP’s jurisdiction due to current statutes or Rules, meter data supporting DER Light or Heavy settlement must still be provided to ERCOT and must have the same level of integrity as that read by a TDSP.
- 4) Clarify whether DER Light and Heavy, especially the former, would be eligible to receive WSL treatment.
- 5) Clarify whether PUC Subst. Rule §25.213, which requires TDSPs to offer customers a net metering option, prohibits a dual metering option for DER Light or DER Heavy.

Appendix A – Distributed Generation Profile Segment Assignment

Excerpts from Appendix D of the Load Profiling Guide:
<http://www.ercot.com/mktrules/guides/loadprofiling/current>

For ESI IDs that have a Distributed Generation (DG) capacity less than or equal to the DG registration threshold, have signed an interconnection agreement with the TDSP, and are not otherwise required to be assigned the IDRRQ Profile Segment, the TDSP is required to provide ERCOT (ERCOTLoadProfilingDepartment@ercot.com) with documentation, either electronic (preferred) or hard copy, of the following for each applicable ESI ID:

1. Affirmation from the TDSP that the Customer has signed an approved Interconnection Agreement with the TDSP
2. Information as requested on the ERCOT approved form to include:
 - a. ESI ID
 - b. Generation type, e.g., PV, wind, other (specify)
 - c. Interconnection Agreement effective date
 - d. Total inverter capacity (if applicable and available)
 - e. The inverter's published peak efficiency rating (if applicable and available)
 - f. If PV generation is present:
 - Total PV generation capacity in kW (DC)
 - g. If wind generation is present:
 - Total wind generation capacity in kW (DC)
 - h. If generation other than PV or wind is present:
 - I. Type(s) of units
 - II. Total generation capacity in kW (DC)

TDSPs are welcome to submit relevant information to supplement any of the above.

If the generator produces DC power, the AC capacity is defined as the sum of the DC nameplate capacity ratings of the modules installed, multiplied by the inverters' published peak efficiency rating if available, otherwise 95%.

TDSPs shall submit appropriate documentation (as listed above) to ERCOT to initiate a change to the Profile ID assignment. ERCOT shall provide a summary of its review of the requests to the TDSPs within five (5) business days of receiving the documentation. For each approved ESI ID, ERCOT shall then request (via e-mail or other mutually acceptable means) that the TDSP change the Profile ID to reflect the appropriate Distributed Generation Profile Segment for the specified ESI ID, via the normal Texas SET process.

DG Profile Segment assignments shall not change due to a switch in CRs.

If a REP of record discovers that a previously approved ESI ID has become ineligible to be served under a DG Profile Segment, the REP of record shall notify the TDSP and ERCOT that a Profile Segment change is required. If a TDSP discovers that a previously approved ESI ID has become ineligible to be served under a DG Profile Segment, the TDSP of record shall notify ERCOT and also change the Profile Segment to the appropriate default Profile Segment as if the ESI ID represented a new premise without DG. TDSPs shall make reasonable effort to effect the change using the appropriate Texas SET process as soon as possible after they become aware that the premise is no longer eligible to be served under a DG Profile Segment.