

# IMPROVEMENT OF DESIGN CODES TO ACCOUNT FOR ACCIDENT THERMAL EFFECTS ON SEISMIC PERFORMANCE

Amit H. Varma, Kadir Sener, Saahas Bhardwaj  
Purdue University

Andrew Whittaker: Univ. of Buffalo



# INTRODUCTION

- ◆ Project focuses on the effects of accident thermal conditions on the seismic performance of:
  - a) Innovative steel-plate composite SC walls, and
  - b) Conventional reinforced concrete RC walls.

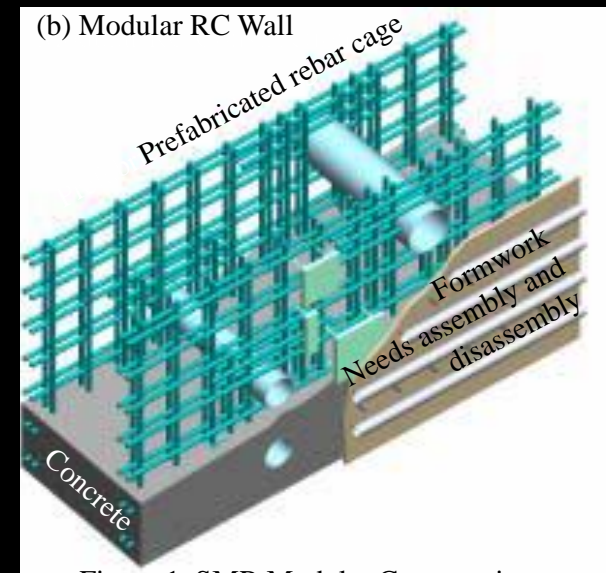
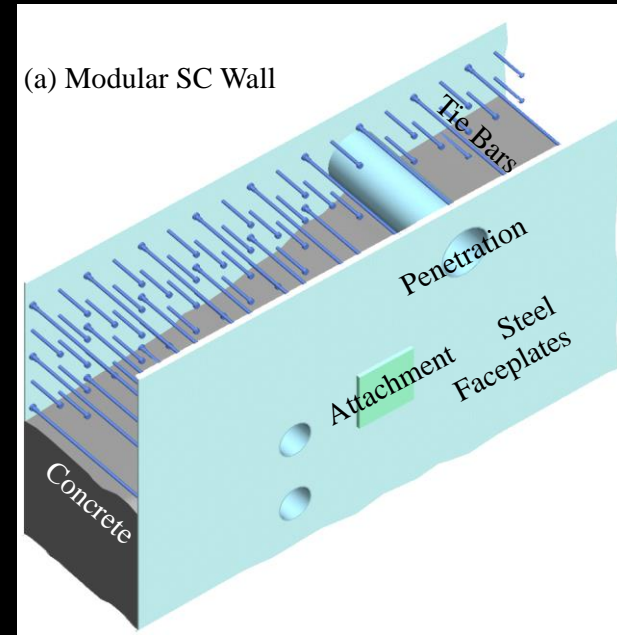

Figure 1. SMP Modular Construction

# MOTIVATION

- ◆ Steel faceplates are directly exposed to elevated temperatures resulting from accident thermal conditions. The resulting differential temperatures and nonlinear thermal gradients lead to concrete cracking
- ◆ Potential overstressing of the steel faceplates (primary reinforcement) during seismic events. Need to address the effects of accident thermal loading on seismic performance.
- ◆ ACI 349 for safety-related RC structures also does not address the effects of accident thermal loading on seismic performance of RC walls.
- ◆ Guidance is needed for regulators, designers, utilities and NSSS vendors.



# PROJECT OBJECTIVES

- ◆ Evaluate the seismic performance of structural walls subjected to accident thermal loading. Parameters:
  - (i) Wall type: SC and RC,
  - (ii) Maximum accident temperature,
  - (iii) Duration of the accident thermal loading before seismic
  - (iv) Details like reinforcement ratio, clear cover, etc.
- ◆ Develop and benchmark numerical models for predicting the seismic performance of structural walls subjected to accident thermal loading
- ◆ Conduct analytical parametric studies to evaluate effects of wide range of material, geometric, structural detailing, thermal loading, and seismic loading parameters including those identified in 1.

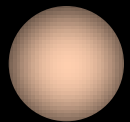

## PROJECT OBJECTIVES (CONT'D)

- ◆ Develop design guidelines and recommendations for accident thermal + seismic loading
  - (i) Recommendations for calculating design demands, and
  - (ii) Calculating the strength and post-peak response
  
- ◆ To disseminate this knowledge and information, and update upcoming design and analysis codes particularly
  - ◆ ACI 349 App. E
  - ◆ ACI 349.1R
  - ◆ AISC N690
  - ◆ ASCE 4 and ASCE 43 to include research findings and guidelines.



# PROJECT TASKS

- ◆ Task 1 – Review and Finalization of Parameters
  - ◆ Industry Partners: Westinghouse Electric, AECOM, Bechtel
  - ◆ Status – Complete
  
- ◆ Task 2 – Accident Thermal Loading and History
  - ◆ Industry Partners, and Review of DCDs, Public NRC documents for AP1000, US-APWR, SMRs etc.
  - ◆ Status – Complete
  
- ◆ Task 3 – Experimental Investigations of SC and RC Walls
  - ◆ Bowen Laboratory using Specialized Heating and Hydraulic Equipment
  - ◆ Status – Ongoing



# PROJECT TASKS

- ◆ Task 4: Development & Benchmarking of Models
  - ◆ Using LS-DYNA, ABAQUS, and other software
  - ◆ Status – Ongoing rigorously
  
- ◆ Task 5 – Analytical Parametric Studies
  - ◆ Using Parameters from Task 1, and Models from Task 4
  - ◆ Status – Ongoing
  
- ◆ Task 6 – Dissemination to Codes / Standards
  - ◆ ACI 349.1R, AISC N690, ASCE 4/43, etc.
  - ◆ Status - Ongoing



# PROJECT SCHEDULE

- ◆ Project progressing as planned
- ◆ No significant deviations or issues so far



|                               | Year 1 |    |    |    | Year 2 |    |    |    | Year 3 |     |     |     |
|-------------------------------|--------|----|----|----|--------|----|----|----|--------|-----|-----|-----|
|                               | Q1     | Q2 | Q3 | Q4 | Q5     | Q6 | Q7 | Q8 | Q9     | Q10 | Q11 | Q12 |
| Task 1: Finalize parameters   | █      | █  |    |    |        |    |    |    |        |     |     |     |
| Task 2: Finalize Accident T-t |        | █  | █  |    |        |    |    |    |        |     |     |     |
| Task 3: Experimental Inv.     |        |    | █  | █  | █      | █  | █  | █  |        |     |     |     |
| Task 4: Numerical Models      |        |    | █  | █  |        |    |    |    |        |     |     |     |
| Task 5: Parametric Studies    |        |    |    |    |        |    | █  | █  | █      | █   |     |     |
| Task 6: Design Guidelines     |        |    |    |    |        |    |    | █  | █      | █   |     |     |



# SIGNIFICANT FINDINGS / OUTCOMES

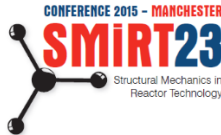

*Transactions, SMiRT-23*  
 Manchester, United Kingdom - August 10-14, 2015  
 Division X



## ACCIDENT THERMAL LOADING EFFECTS ON SEISMIC BEHAVIOUR OF SAFETY-RELATED NUCLEAR STRUCTURES

**Kadir C. Sener<sup>1</sup>, Amit H. Varma<sup>2</sup> and Saahastaranshu R. Bhardwaj<sup>3</sup>**

<sup>1</sup> Research Engineer, Lyles School of Civil Engineering, Purdue University, West Lafayette, IN, USA

<sup>2</sup> Professor, Lyles School of Civil Engineering, Purdue University, West Lafayette, IN, USA

<sup>3</sup> Ph.D. student, Lyles School of Civil Engineering, Purdue University, West Lafayette, IN 47906, USA

### ABSTRACT

The Fukushima event of 2011 has highlighted the importance of designing safety-related nuclear facilities for accident thermal scenarios combined with design basis (safe shutdown) earthquake. While the probability of both events occurring simultaneously is low, severe environmental conditions may trigger accident thermal loading, and subsequent aftershocks, potentially as intense as the main shock, may occur during the accident thermal event. Current design codes and standards in the United States and abroad provide little-to-no guidance for including the effects of accident thermal loading on seismic behaviour (stiffness, strength, ductility or reserve margin) of structures. Prior research has focused on seismic behaviour or accident thermal loading but not both in combination. This is valid for both existing conventional reinforced concrete (RC) and modern steel-plate composite (SC) structures.

The authors have initiated a research project focussing on the effects of accident thermal scenarios on the in-plane shear behaviour (stiffness and strength) of SC and RC wall structures. This paper presents the initial findings from the project including: (i) typical temperature-time ( $T-t$ ) curves for containment internal structures in pressurized water reactors, (ii) thermal gradient histories that develop through the concrete thickness, (iii) concrete cracking due to the severe gradient and internal restraint, (iv) in-plane shear behaviour of the wall after concrete cracking, and (v) effects of external restraints on the in-plane shear behaviour. The paper presents these findings related to both RC and SC walls, which are being used to develop the test matrix and parameters to be included in the experimental investigations that will be conducted in the next phase of the project.



# ACCIDENT THERMAL LOADING

- ◆ Typical accident temperature-time histories for the CIS of nuclear power plants (NPPs) are identified using envelopes of T-t histories from publicly available Design Control Documents (AP1000, US-APWR).

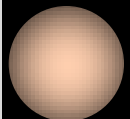
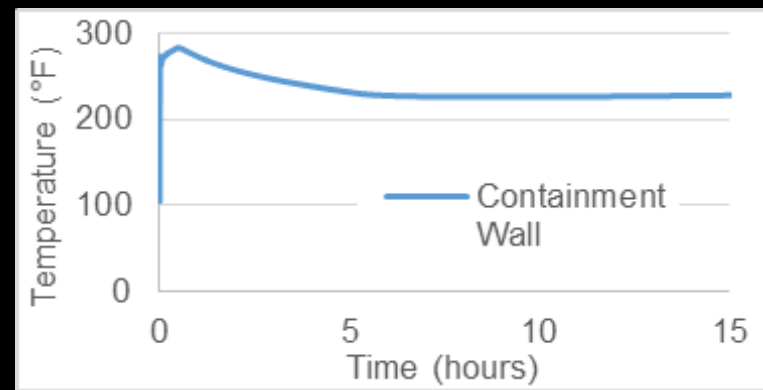
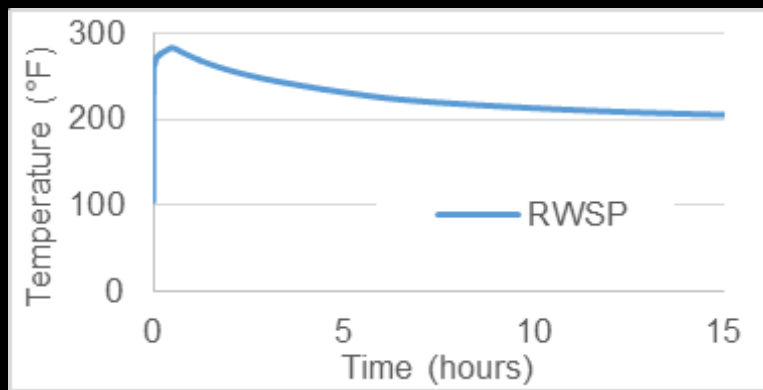
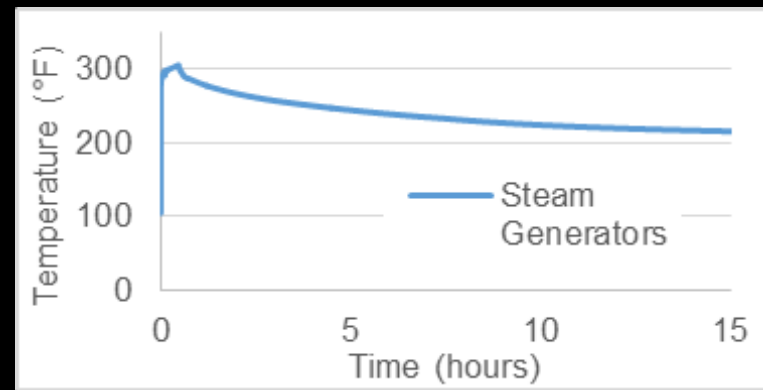
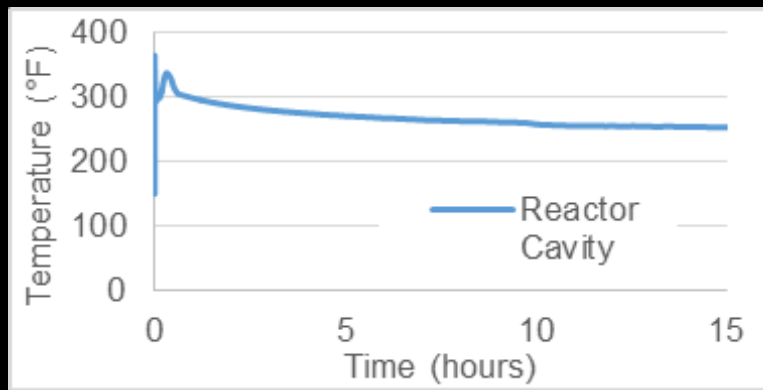

# BENCHMARKING OF PRELIMINARY MODELS

- ◆ Finite element models were benchmarked using results from SC wall experiments conducted in Japan by Ozaki et al. (2004).
  - ◆ Three unheated specimens: **S200NN**, **S300NN** ( $\rho=3.2\%$ ), and **S400NN**
  - ◆ Two heated specimens: **S200TH** ( $\rho=2.3\%$ ) and **S400TH** ( $\rho=4.5\%$ )
  - ◆ Same overall dimensions (47.2 in. x 47.2 in. x 7.87 in.)

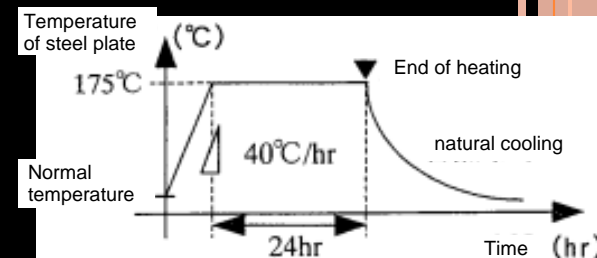
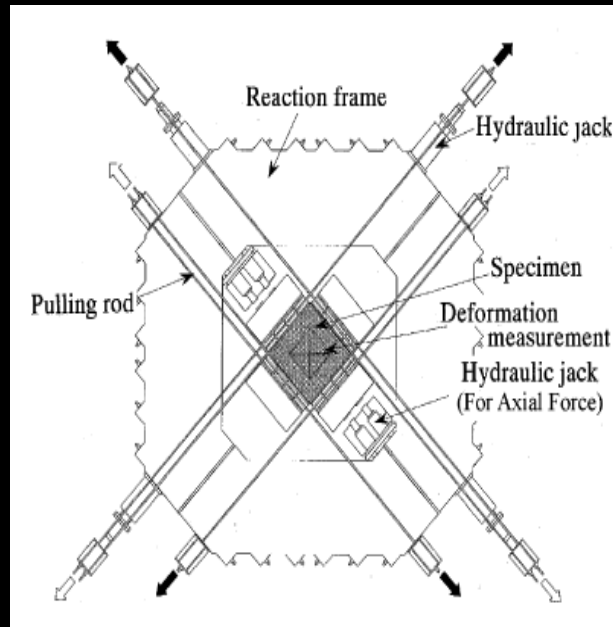
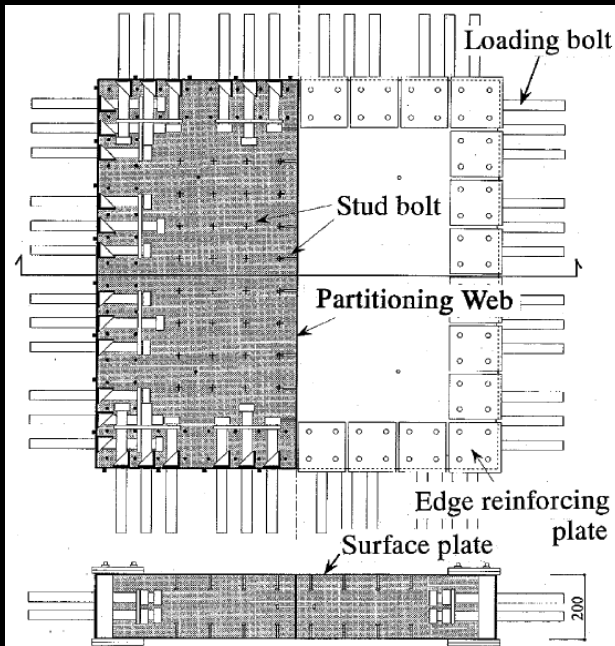

# BENCHMARKING OF PRELIMINARY MODELS

- ◆ Layered shell finite element models were used to benchmark the numerical models.
  - ◆ Sequentially coupled thermal-mechanical analysis

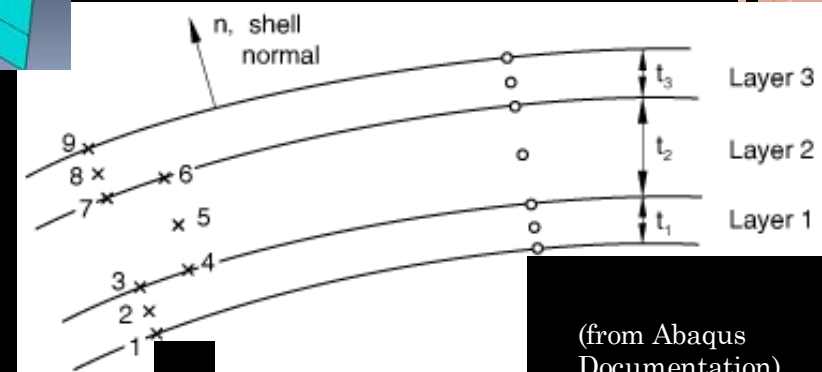
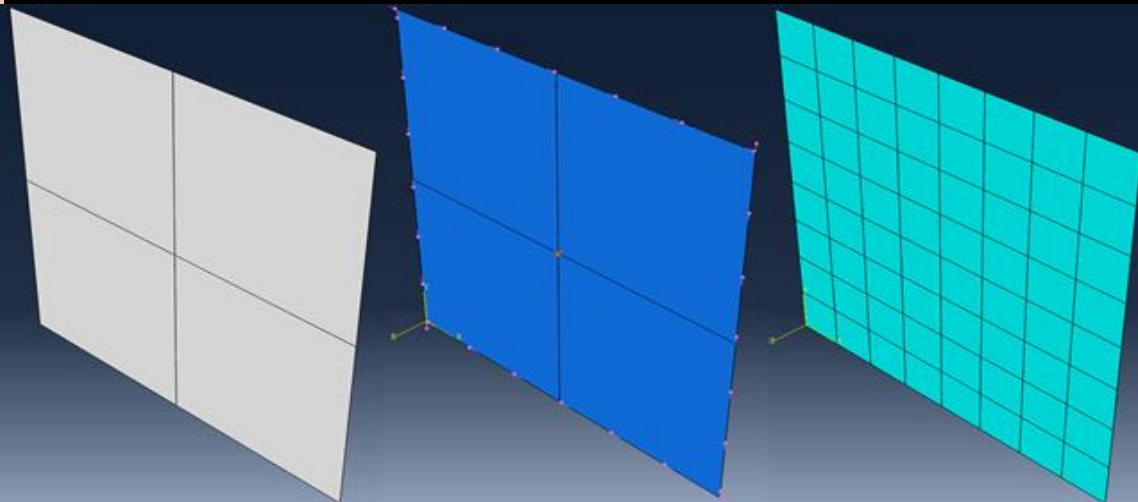

(from Abaqus Documentation)

## BENCHMARKING OF PRELIMINARY MODELS

- ◆ Steel behavior was modeled using multi-axial plasticity theory
  - ◆ Von Mises yield surface
  - ◆ Associated flow rule
  - ◆ Isotropic hardening
  - ◆ Thermal properties and temperature dependent stress-strain curves according to the Euro code (CEN, 2001)
- ◆ Concrete behavior was modeled using smeared crack theory
  - ◆ Linear Drucker-Prager compression yield surface with associated flow rule in compression
  - ◆ Crack detection using Rankine criterion
  - ◆ Post cracking behavior was based on fracture energy and empirical models using CEB-FIB (1990)
  - ◆ Temperature dependent elastic modulus of concrete in accordance with NIST and Eurocode recommendations (Phan et al. 2010)

# BENCHMARKING OF PRELIMINARY MODELS

- ◆ Force vs. shear strain comparisons with test results

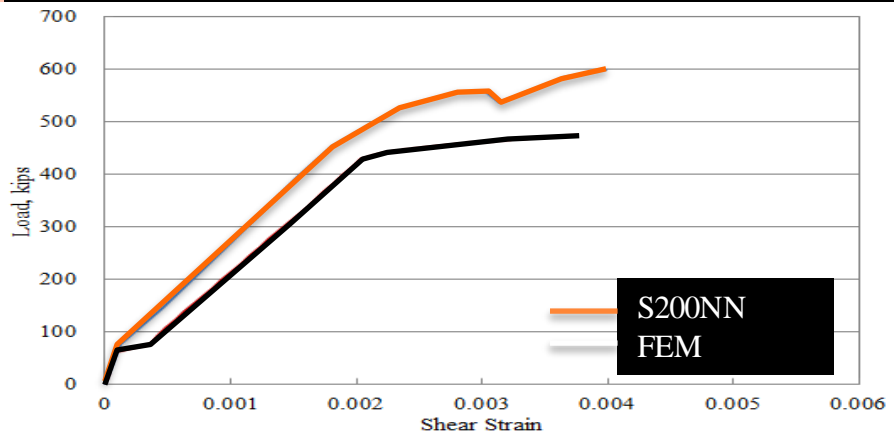

S200NN

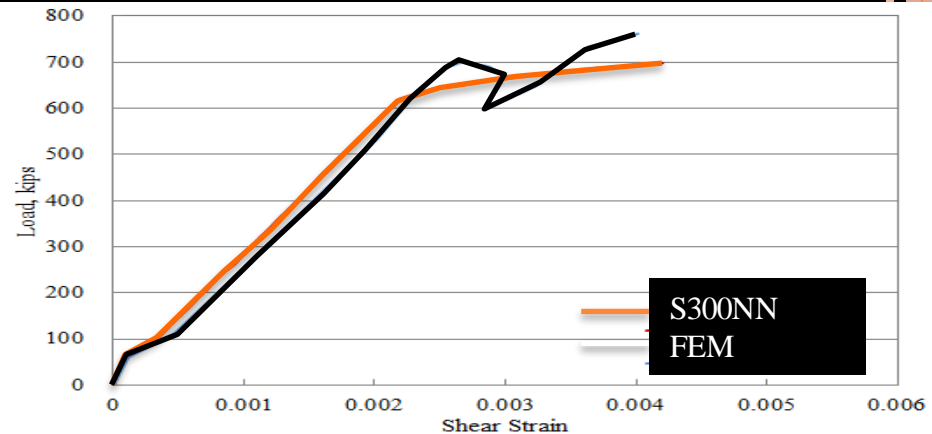

S300NN

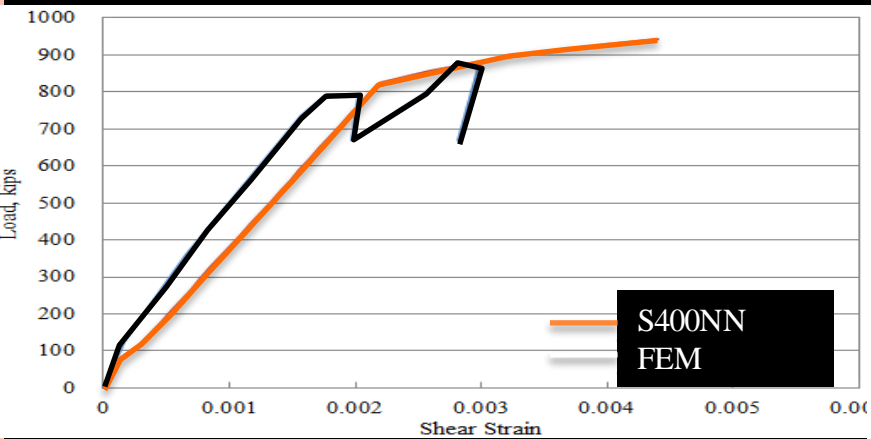

S400NN

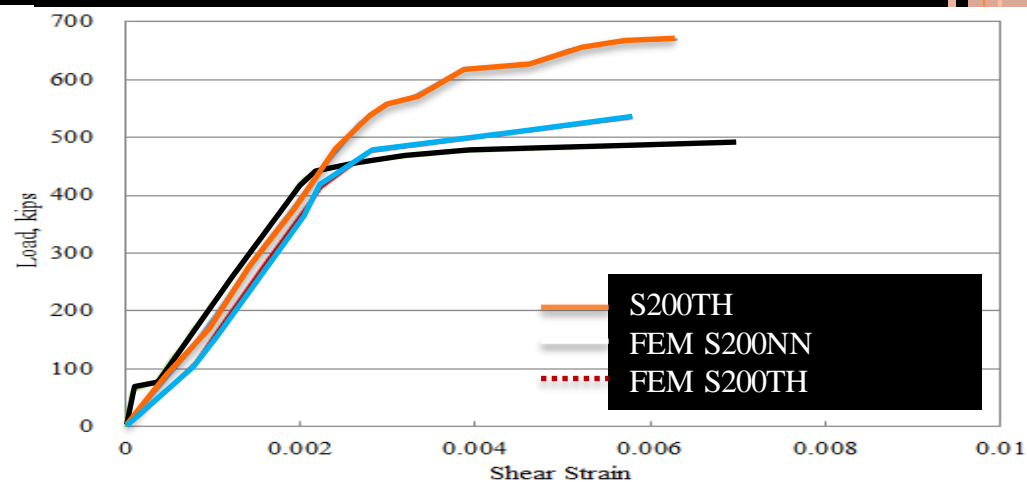

S200TH

# ANALYTICAL PARAMETRIC STUDY

- ◆ Benchmarked models were used for a combined in-plane shear + thermal loading scenario.
  - ◆ Four different reinforcement ratio ( $\rho=1.5\%$ ,  $2\%$ ,  $3\%$ , and  $4\%$ )
  - ◆ Three temperature amplitudes ( $T=150, 300, 450$  F)
  - ◆ Rectangular panel of 8 ft. x 8 ft. in height and width, and 4 ft. thick.

Loading-Time History

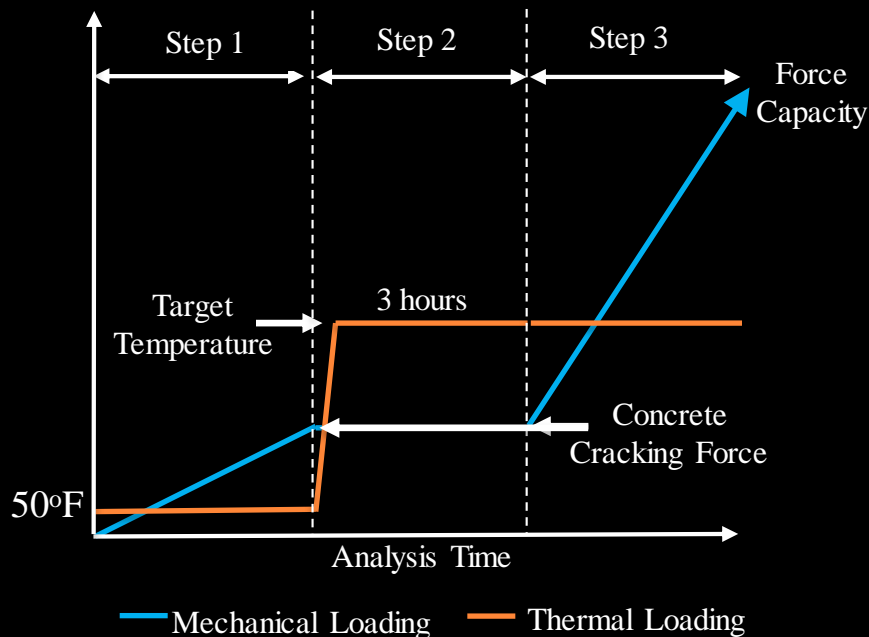

Thru-thickness temperature variation

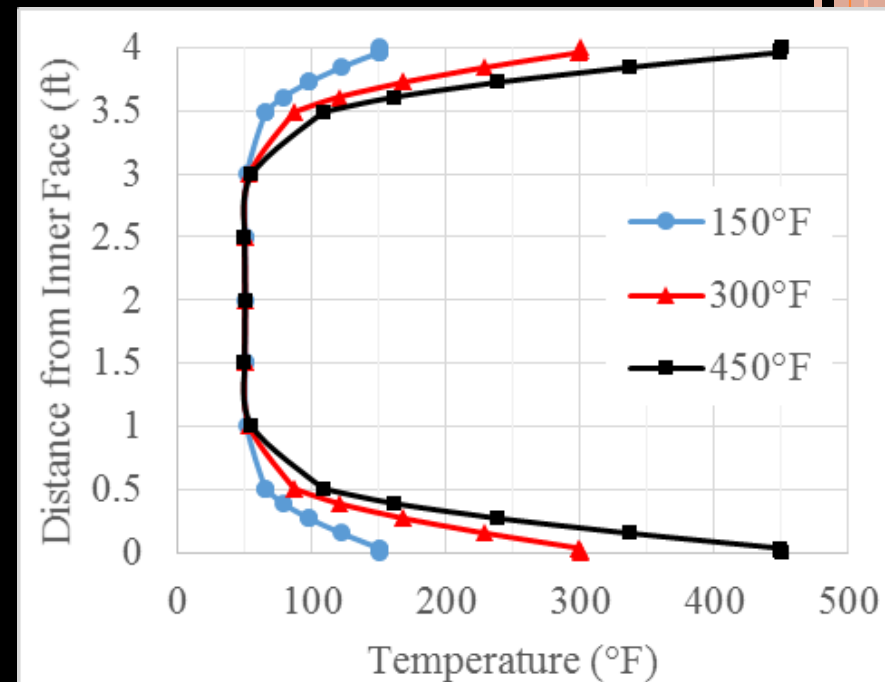

# MECHANICS BASED THEORY

- The in-plane shear strength of SC composite walls can be estimated as the tri-linear shear force – strain curve.

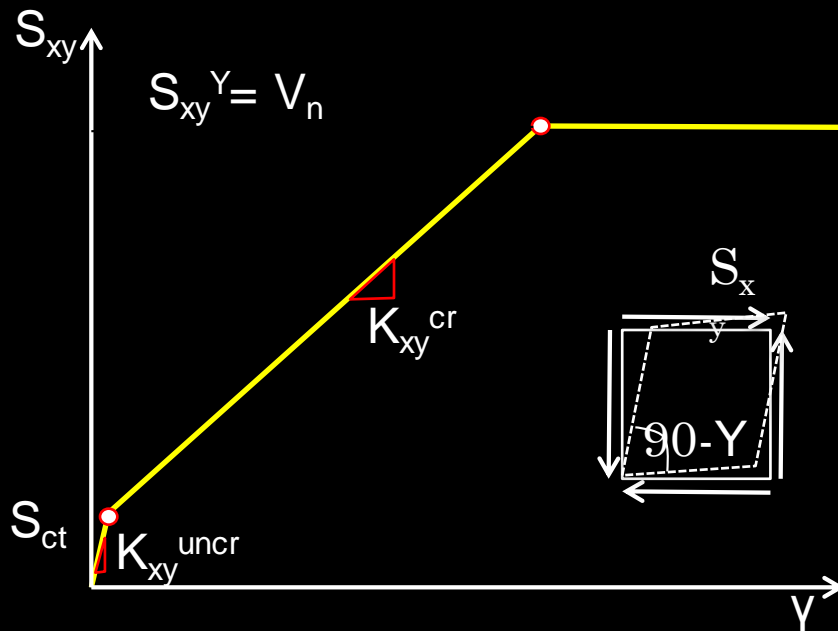

$$K_{xy}^{uncr} = G_s A_s + G_c A_c \quad \text{Equation 1}$$

$$S_{ct} = \frac{2\sqrt{f'_c}}{1000} \left( \frac{E_c A_c + E_s A_s}{E_c} \right) \quad \text{Equation 2}$$

$$K_{xy}^{cr} = K_{sc} + K_s = \frac{1}{\frac{4}{0.7E_c A_c} + \frac{2(1-n_s)}{E_s A_s}} + G_s A_s \quad \text{Equation 3}$$

$$S_{xy}^Y = V_n^{in} = \frac{K_s + K_{sc}}{\sqrt{3K_s^2 + K_{sc}^2}} \times A_s F_y \quad \text{Equation 4}$$



# ANALYTICAL PARAMETRIC STUDY

◆ Representative analysis results.  $\rho = 2\%$

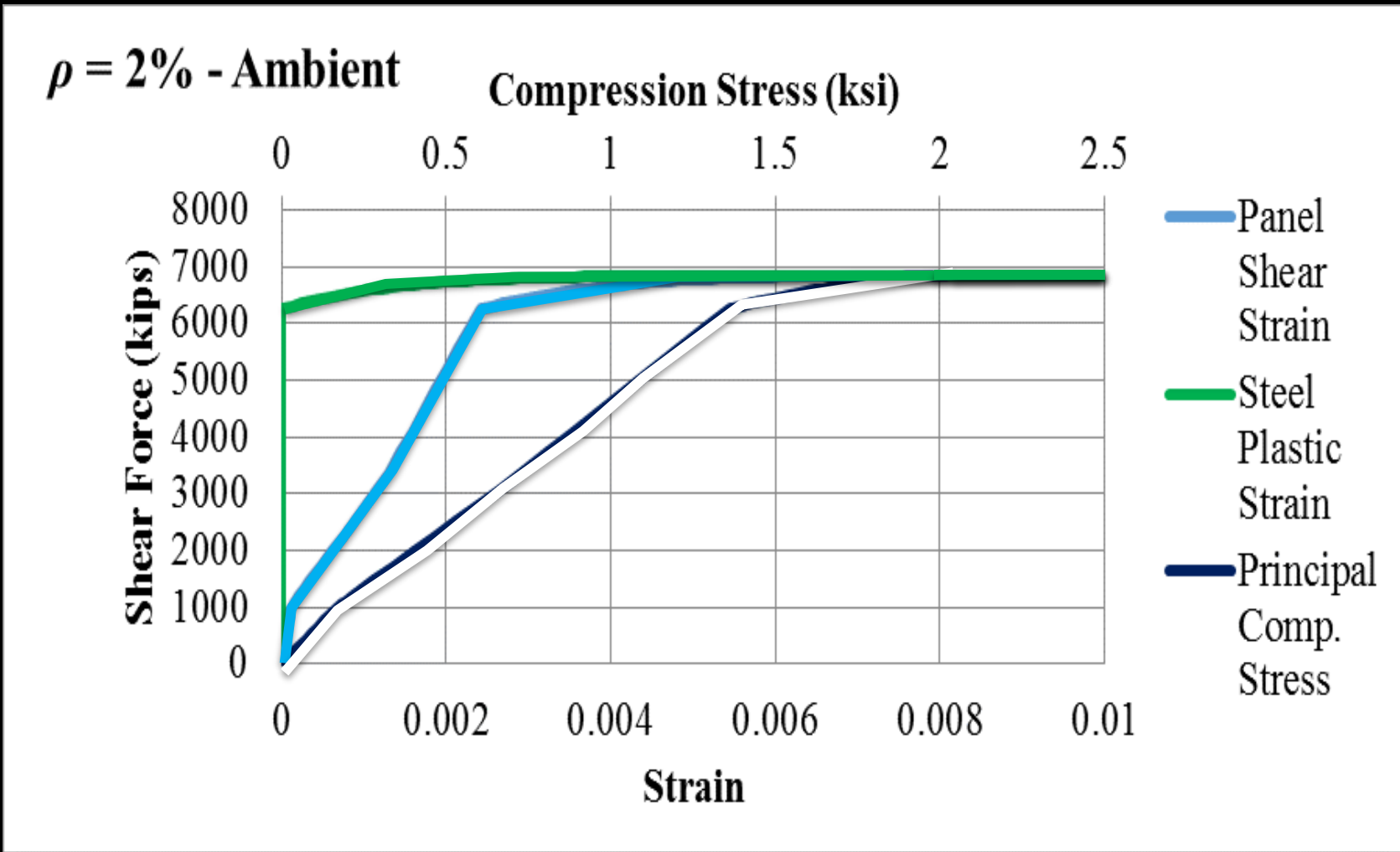

# ANALYTICAL PARAMETRIC STUDY

◆ Representative analysis results.  $\rho = 2\%$

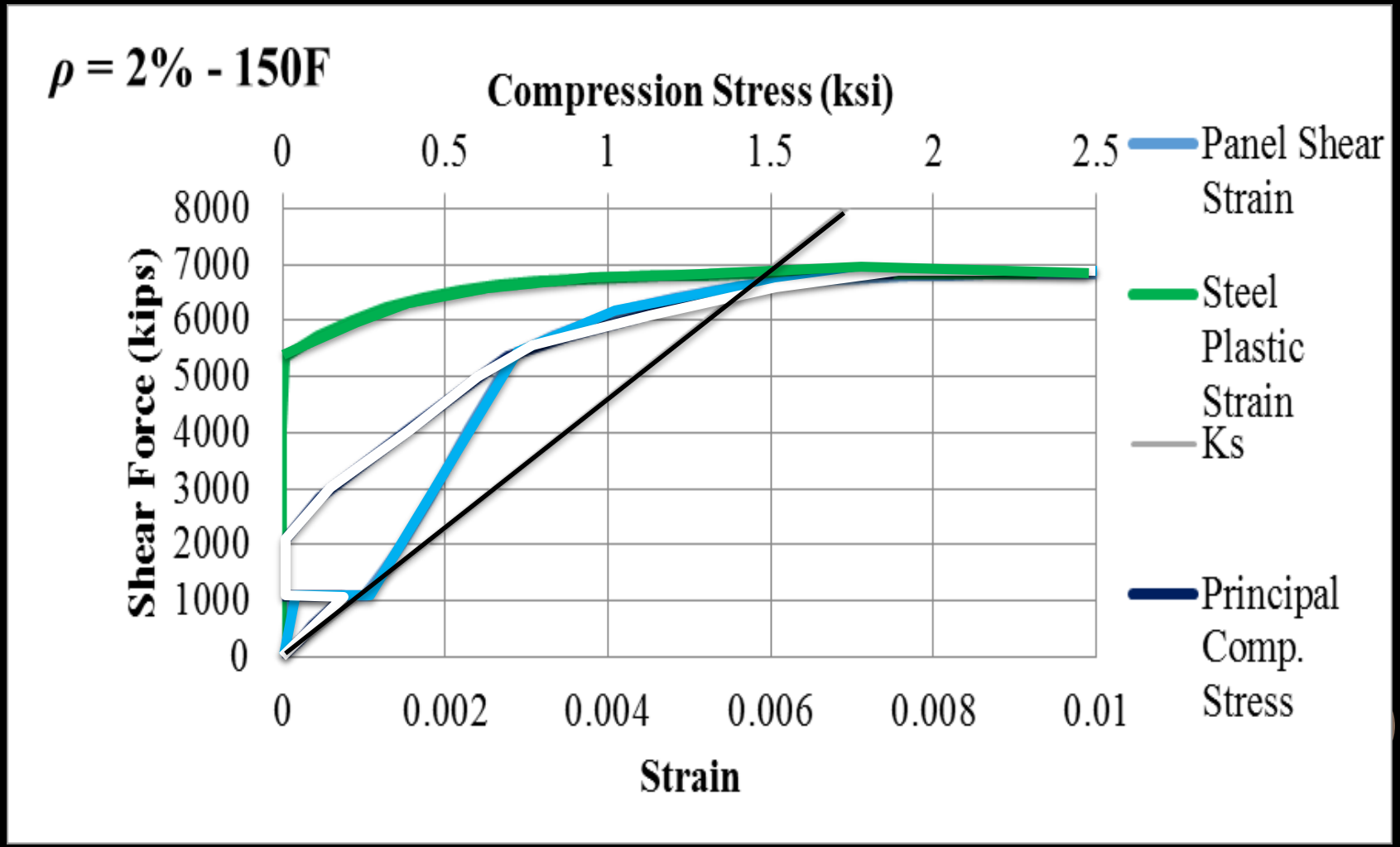

# ANALYTICAL PARAMETRIC STUDY

◆ Representative analysis results.  $\rho = 2\%$

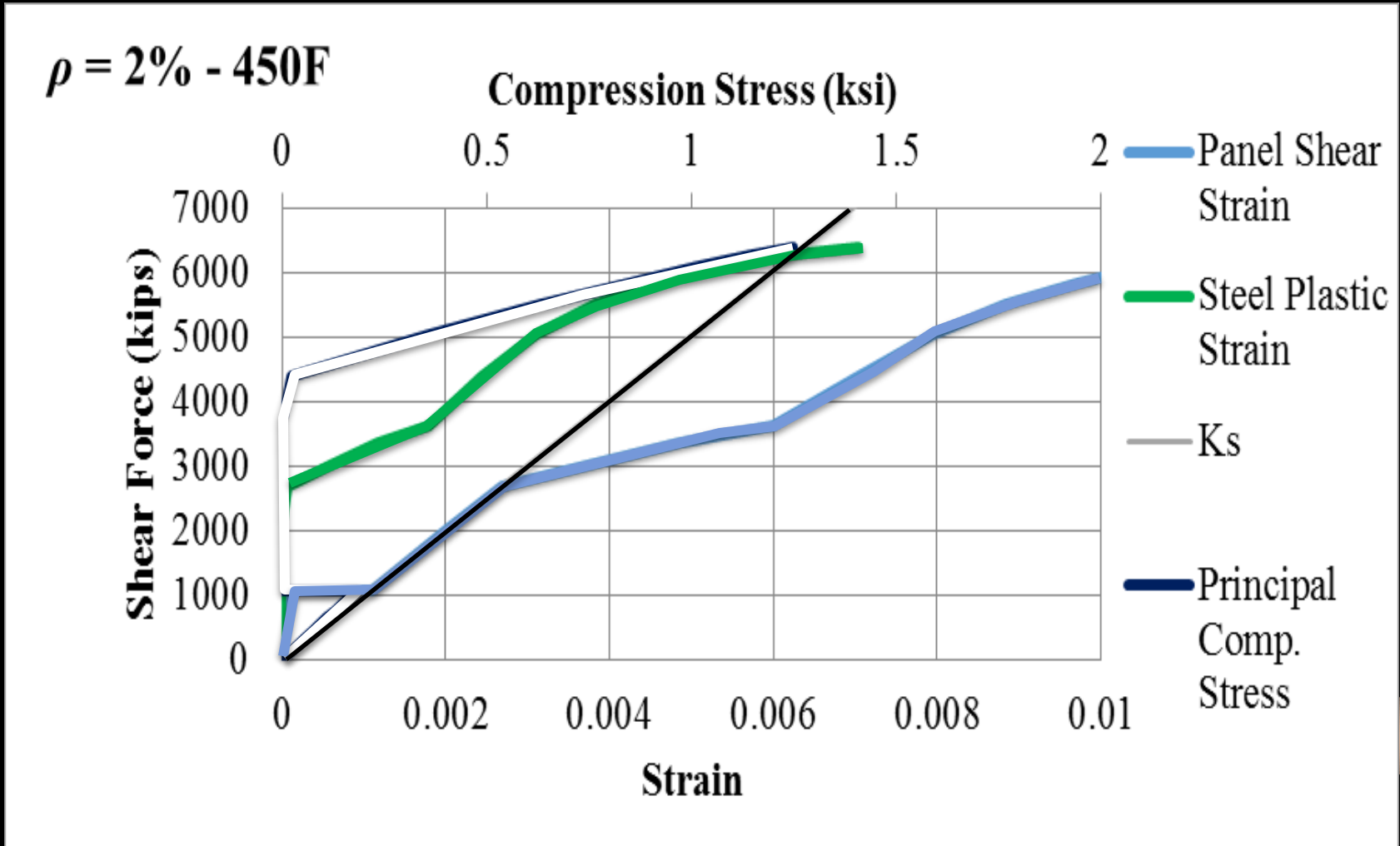

# ANALYTICAL PARAMETRIC STUDY

- ◆ Implementation of restrain condition.

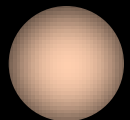
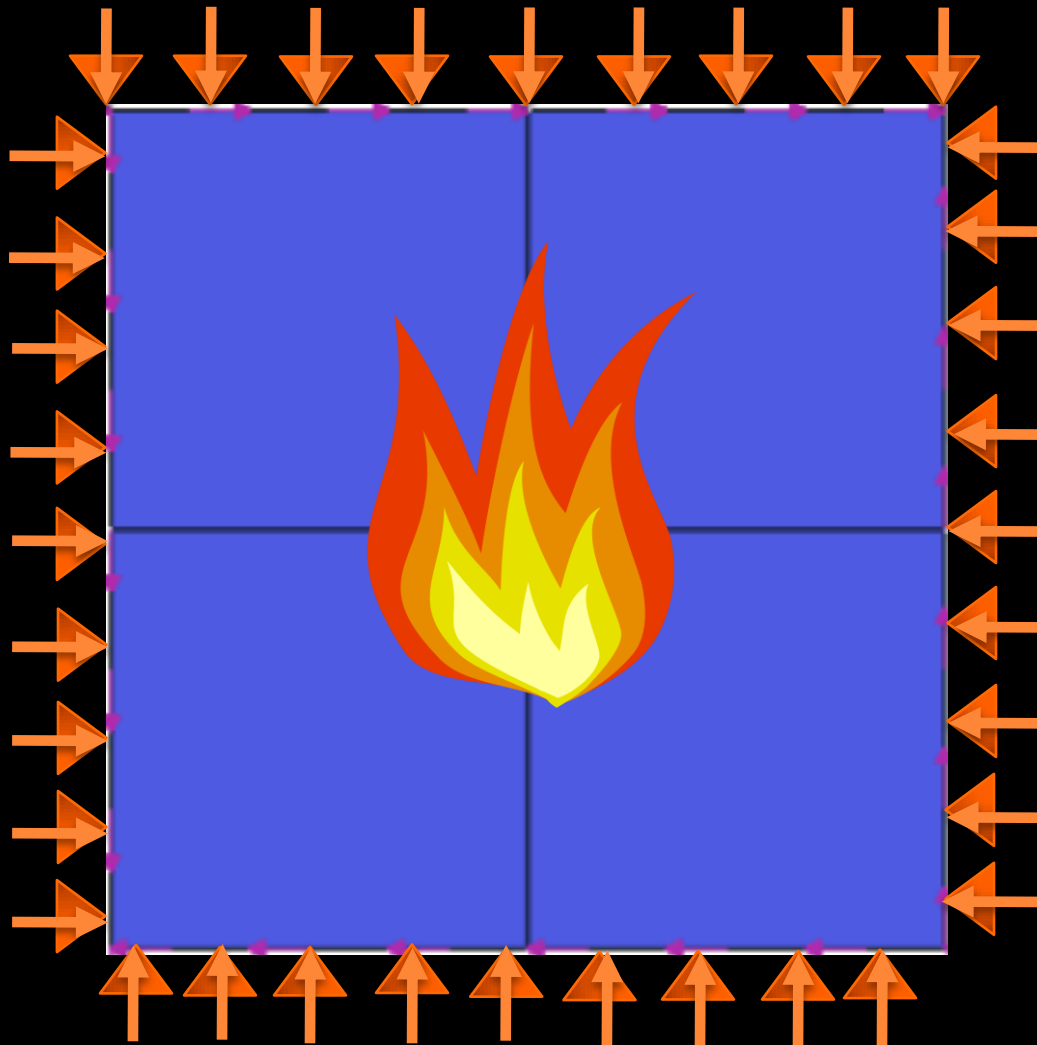

# ANALYTICAL PARAMETRIC STUDY

- ◆ Representative analysis results for restrained condition.

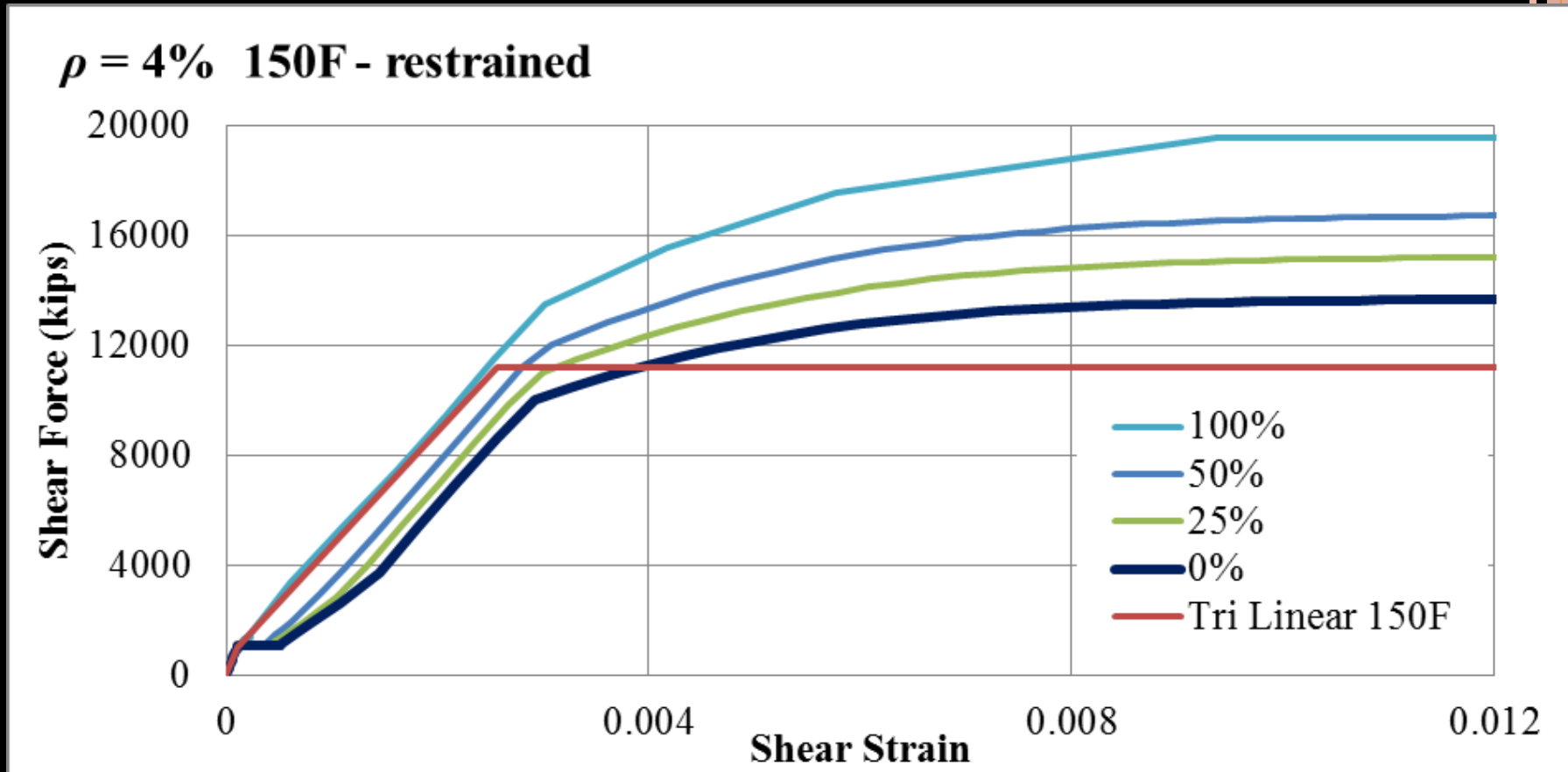

# ANALYTICAL PARAMETRIC STUDY

## ◆ Strength comparisons

| $V_{max}^{\rho=1.5\%}$ / Eq. 4 |       |       |       | $V_{max}^{\rho=2\%}$ / Eq. 4 |       |       |       | $V_{max}^{\rho=3\%}$ / Eq. 4 |       |       |       | $V_{max}^{\rho=4\%}$ / Eq. 4 |       |       |       |
|--------------------------------|-------|-------|-------|------------------------------|-------|-------|-------|------------------------------|-------|-------|-------|------------------------------|-------|-------|-------|
| Amb.                           | 150°F | 300°F | 450°F | Amb.                         | 150°F | 300°F | 450°F | Amb.                         | 150°F | 300°F | 450°F | Amb.                         | 150°F | 300°F | 450°F |
| 1.09                           | 1.01  | 0.95  | 0.54  | 1.12                         | 1.09  | 0.91  | 0.61  | 1.16                         | 1.12  | 0.94  | 0.66  | 1.20                         | 1.14  | 0.96  | 0.63  |

$$K_{xy}^{uncr} = G_s A_s + G_c A_c \quad (1)$$

$$S_{ct} = \frac{2\sqrt{f'_c}}{1000} \left( \frac{E_c A_c + E_s A_s}{E_c} \right) (psi) \quad (2)$$

$$K_{xy}^{cr} = \frac{1}{\frac{4}{0.7E_c A_c} + \frac{2(1-\nu_s)}{E_s A_s}} + G_s A_s \quad (3)$$

$$S_{xy}^y = \frac{K_s + K_{sc}}{\sqrt{3K_s^2 + K_{sc}^2}} \times A_s F_y \quad (4)$$

# SUMMARY & CONCLUSIONS

- ❖ Typical temperature-time (T-t) curves for containment internal structures in pressurized water reactors are identified.
- ❖ The in-plane shear stiffness and strength of SC walls increased with increasing reinforcement ratio. The pre-cracking branch was almost identical for all reinforcement levels.
- ❖ The analysis results of this study show that the reinforcement ratio and temperature amplitude have remarkable influence on the behavior of SC walls

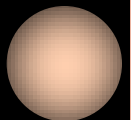

- ❖ Both shear stiffness and shear strength are reduced at elevated temperature and this becomes more significant at high temperature amplitudes (300°F and 450°F).
- ❖ The shear stiffness comparisons indicate that the 25% and 50% restraint cases result in similar stiffness as the unrestrained case, but with strength increases of about 20% to 40%.
- ❖ The tri-linear approach by Varma et al. (2011) can be used to predict the behavior of SC walls subjected to combined thermal + in-plane shear loading for most of the SC wall panel model cases.



# FLANGED SC WALL TESTS IN LITERATURE

- ◆ Recent work by Japanese Researchers (Kitajima et al. 2015).
- ◆ 1/7 scale SC walls with flange plates tested under accident thermal loading.
  - ◆  $t_{SC} = 285 \text{ mm (11.2 in.)}$ ,  $t_p = 2.3 \text{ mm (0.09 in.)}$ ,  $t_{p.end\_plate} = 22 \text{ mm (0.87 in.)}$
- ◆ Test program included six specimens having test parameters of max temperature, heating duration, initial membrane force and cyclic loading hysteresis.

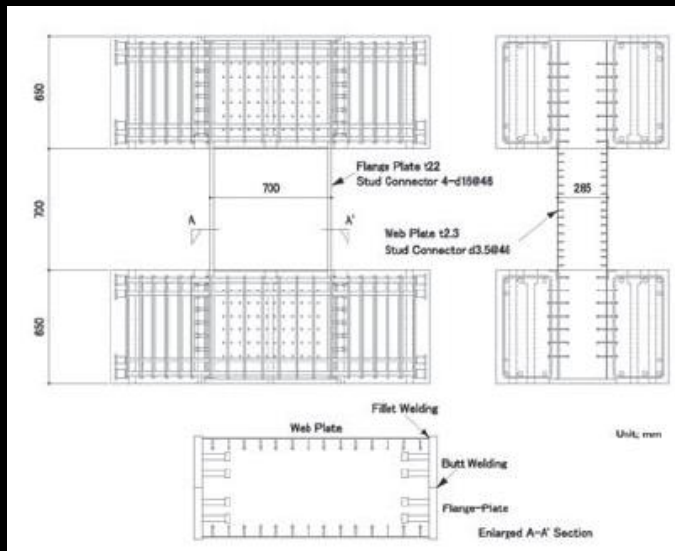

700 mm x 700 mm  
 (27.6 in x 27.6 in)  
 $H/L = 0.5$

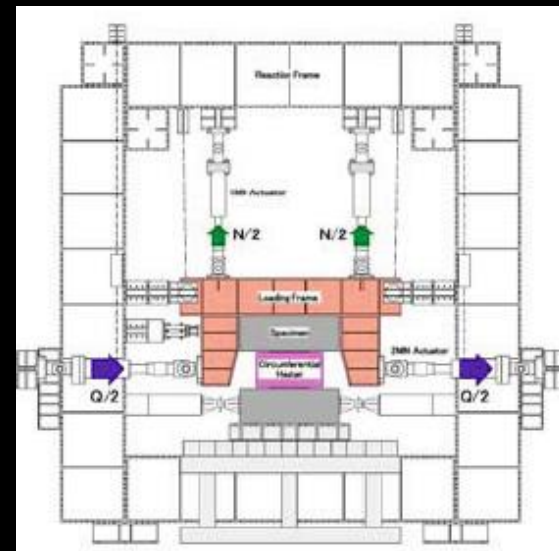

# FLANGED SC WALL TESTS IN LITERATURE

- Recent work by Japanese Researchers (Kitajima et al. 2015).

| No. | Temperature and heating duration | Membrane force | Loading hysteresis |                          |
|-----|----------------------------------|----------------|--------------------|--------------------------|
| 1   | Room temperature                 | 1600 kN        | Monotonic          | Operating time + seismic |
| 2   | Room temperature                 | None           | Monotonic          | Effect of axial tension  |
| 3   | 145 °C for 30 days               | None           | Monotonic          | DBA + seismic            |
| 4   | 145 °C for 30 days               | None </tr      |                    |                          |

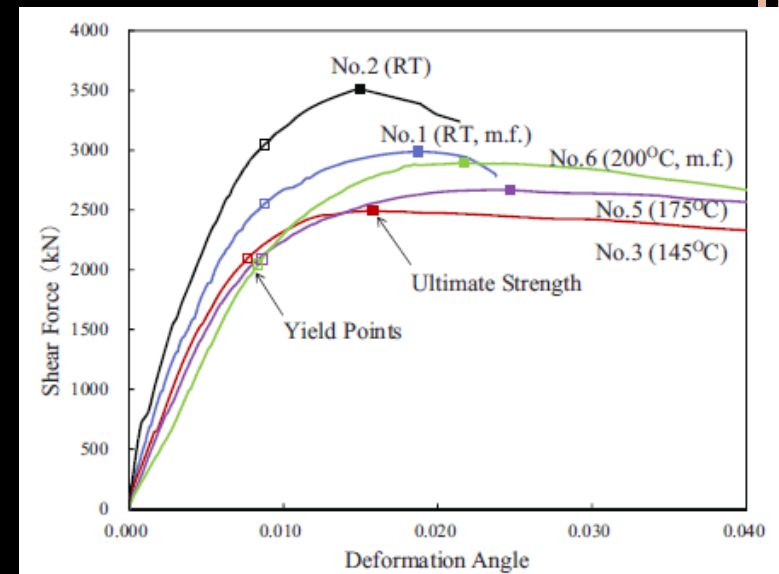

- Test results showed that the ultimate strength reduced by 25% due to the thermal loading. Also significant reduction (50%) in the initial stiffness.



# FLANGED SC WALL TESTS IN LITERATURE

- ◆ Numerical Analysis of tests by Kitajima et al. (2015).

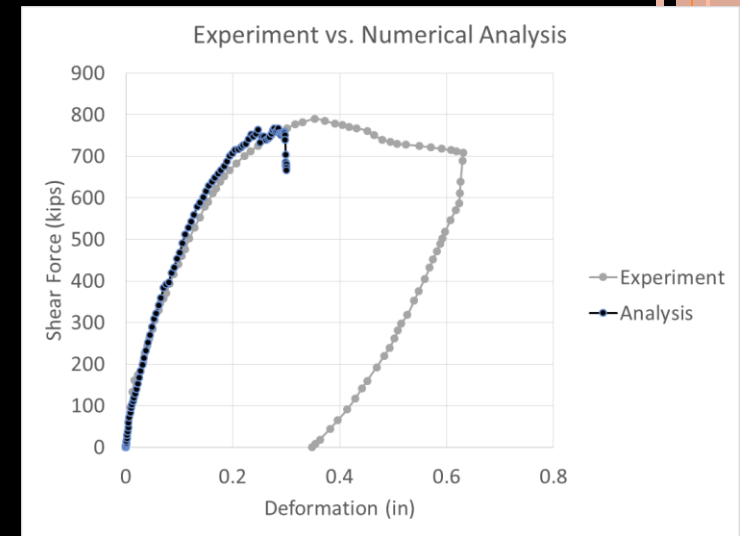
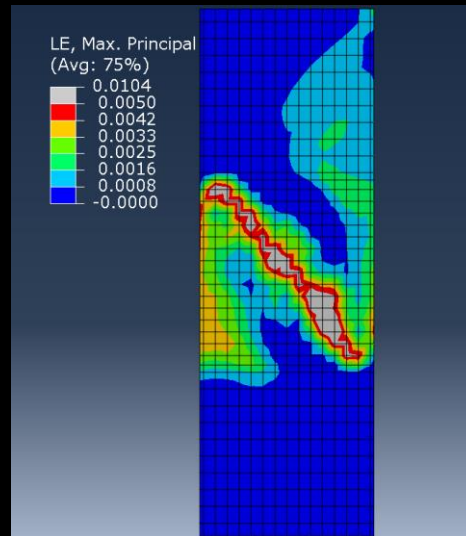
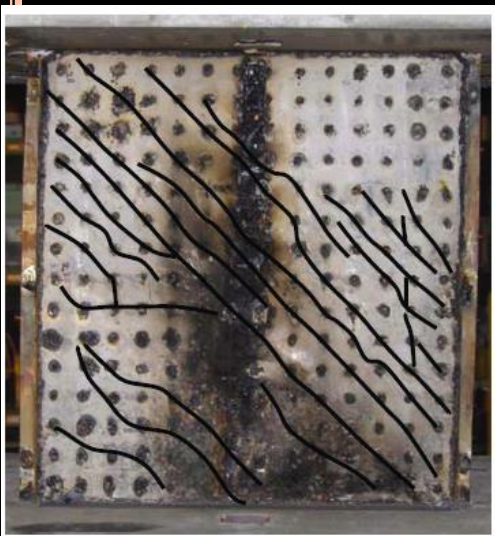

- ◆ Stiffness, strength and crack patterns of the tested specimen (No. 2) is captured accurately by numerical modeling.
- ◆ These benchmarked models are used to verify the behavior of designed specimens



# CONCEPTUAL DESIGN OF PROPOSED SPECIMENS

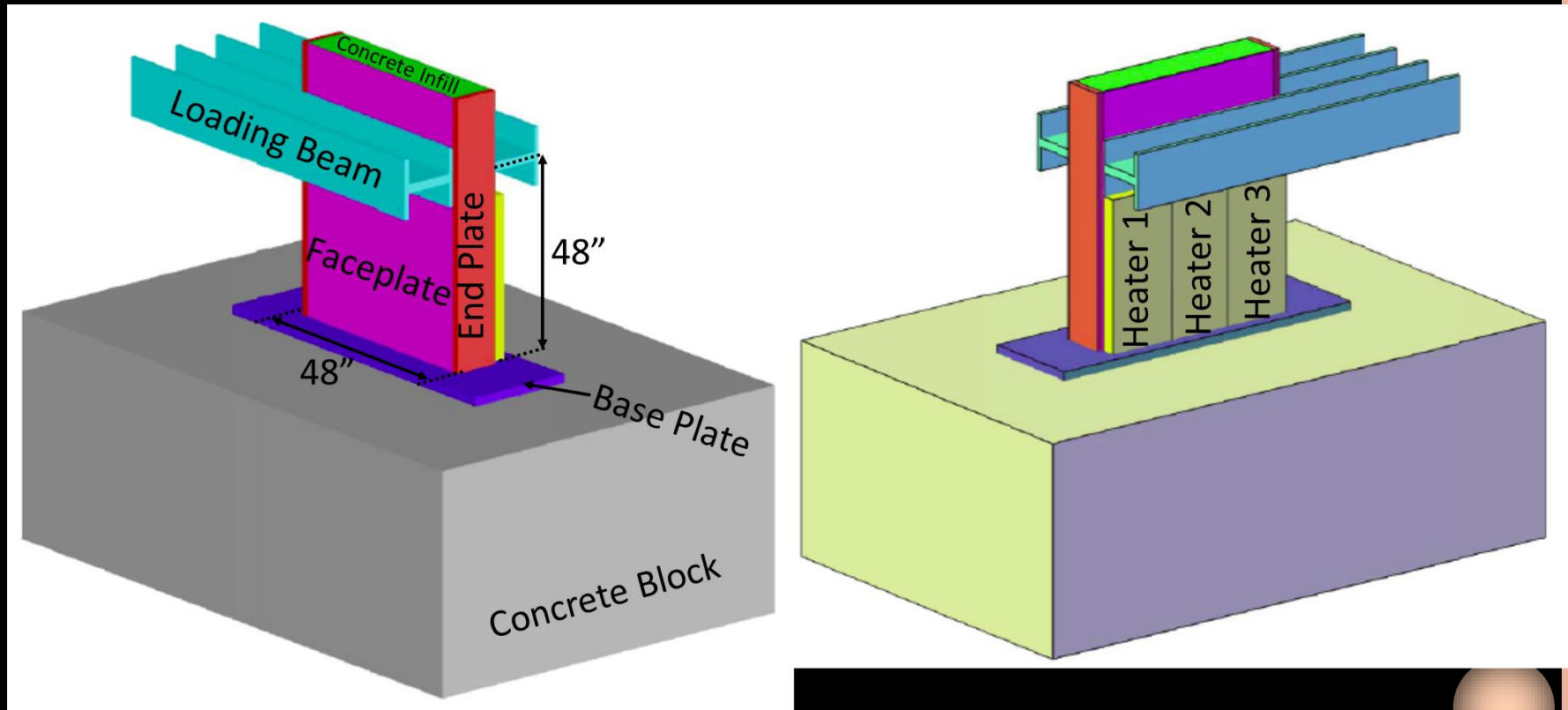

# PROPOSED EXPERIMENTAL ACTIVITY

- ◆ Six flanged SC and RC specimens to be tested.

| Specimen ID  | Wall thick. (T) | Plate thick. (t <sub>p</sub> ) | Reinf. ratio % | Tie spacing (S) | Shear stud s/t <sub>p</sub> ratio | End plate thick. (t <sub>p, end, pl</sub> ) | Max. temp. | Heating duration | Comment             |
|--------------|-----------------|--------------------------------|----------------|-----------------|-----------------------------------|---|------------|------------------|---------------------|
| S-2.1-A-0    | 10 in.          | 0.1046 in (12ga)               | 2.1%           | 5 in.           | 24                                | 1 in.                                       | Amb.       | -NA-             | Control Specimen    |
| S-2.1-300-1  | 10 in.          | 0.1046 in (12ga)               | 2.1%           | 5 in.           | 24                                | 1 in.                                       | 300°F      | 1 hour           | Effect of heating   |
| S-2.1-300-3  | 10 in.          | 0.1046 in (12ga)               | 2.1%           | 5 in.           | 24                                | 1 in.                                       | 300°F      | 3 hour           | Duration of heating |
| S-2.1-450-3  | 10 in.          | 0.1046 in (12ga)               | 2.1%           | 5 in.           | 24                                | 1 in.                                       | 450°F      | 3 hour           | Max. temperature    |
| S-3.8-450-3  | 10 in.          | 0.1875 in (3/16")              | 3.8%           | 9 in.           | 24                                | 1 in.                                       | 450°F      | 3 hour           | Reinforcement ratio |
| S-3.8-300-24 | 10 in.          | 0.1875 in (3/16")              | 3.8%           | 9 in.           | 24                                | 1 in.                                       | 300°F      | 24 hour          | Long term heating   |

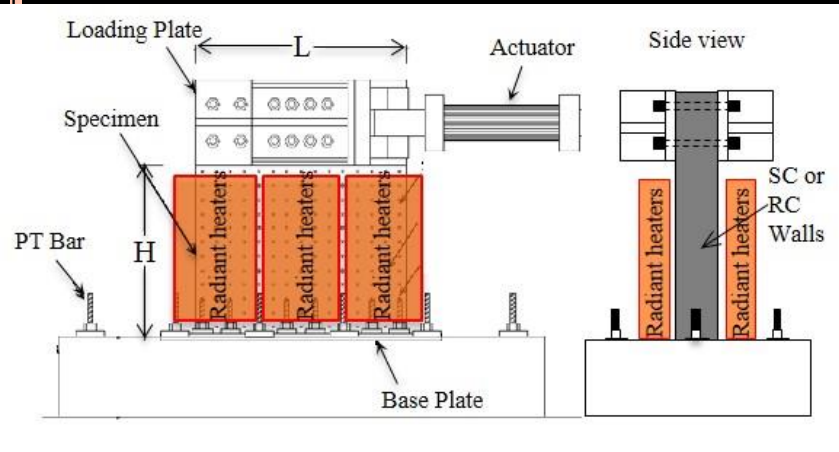

| Specimen ID    | Wall thick. (T) | Rebar size & spacing | Reinf. ratio % | Stirrup spacing (S) | Clear cover (in.) | Max. temp. | Heating duration | Comment             |
|----------------|-----------------|----------------------|----------------|---------------------|-------------------|------------|------------------|---------------------|
| R-1.4-A-0-1    | 10 in.          | #6@4in.              | 2.2%           | #3@8in              | 1 in.             | Amb.       | -NA-             | Control Specimen    |
| R-1.4-300-1-1  | 10 in.          | #6@4in.              | 2.2%           | #3@8in              | 1 in.             | 300°F      | 1 hour           | Effect of heating   |
| R-1.4-300-3-1  | 10 in.          | #6@4in.              | 2.2%           | #3@8in              | 1 in.             | 300°F      | 3 hour           | Duration of heating |
| R-1.4-450-3-2  | 10 in.          | #6@4in.              | 2.2%           | #3@8in              | 2 in.             | 450°F      | 3 hour           | Max. temperature    |
| R-1.4-450-3-2  | 10 in.          | #6@4in.              | 2.2%           | #3@8in              | 2 in.             | 450°F      | 3 hour           | Clear Cover         |
| R-1.4-300-24-1 | 10 in.          | #6@4in.              | 2.2%           | #3@8in              | 1 in.             | 300°F      | 24 hour          | Long term heating   |

# SIGNIFICANT FINDINGS / OUTCOME



*Transactions, SMiRT-23*  
Manchester, United Kingdom - August 10-14, 2015  
Division X

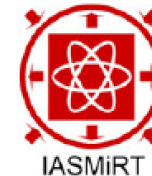

## ON THE CALCULATION OF DESIGN DEMANDS FOR ACCIDENT THERMAL LOADING COMBINATION

Saahastaranshu R. Bhardwaj<sup>1</sup>, Amit H. Varma<sup>2</sup>, Kadir C. Sener<sup>3</sup>

<sup>1</sup> Ph.D. student, Lyles School of Civil Engineering, Purdue University, West Lafayette, IN 47906, USA

<sup>2</sup> Professor, Lyles School of Civil Engineering, Purdue University, West Lafayette, IN, USA

<sup>3</sup> Research Engineer, Lyles School of Civil Engineering, Purdue University, West Lafayette, IN, USA

### ABSTRACT

Reinforced concrete walls and slabs in safety-related nuclear facilities are required to be designed for abnormal load combinations. This paper evaluates the design force demands on safety-related nuclear structures due to accident thermal loads. Thermal loading conditions and effects of thermal loads and restraints on structural behavior are discussed. Idealized possible structure geometries for nuclear facilities are analyzed and the modeling and analysis parameters are briefly discussed. Selected structures are subject to LEFE and NIFE analysis for idealized accident thermal loads. The demands from LEFE and NIFE analysis are compared to predict the effectiveness of simple LEFE analysis. The demand to capacity ratio (DCR) for individual demands are also calculated. Additionally, the paper delves into the effectiveness of concrete clear cover in reducing the magnitude of stresses due to thermal loads.

## OBJECTIVE

- ◆ The objective of this research (and paper) is to propose a consistent methodology that can be used with LEFE analysis to calculate the reduced design force demands in typical RC structures subjected to accident thermal loading

## APPROACH

- ◆ Consider typical thermal loads and scenarios in design, and understand the sources of cracking, yielding etc.
- ◆ Posit a methodology for calculating the design force demands using LEFE analysis, reduced stiffness due to cracking, and linear (or uniform) thermal gradient through the cross-section
- ◆ Consider a range of typical but simple NPP structures subjected to realistic accident thermal loads



# APPROACH

- ◆ Develop NIFE models of these simple NPP structures, while accounting for concrete cracking, steel yielding etc. and calculate the associate demands
- ◆ Develop LEFE models of these structures, and use the posited methodology to calculate the associated demands
- ◆ Fine tune the parameters / recommendations for the posited method so that the design demands are conservative with respect to the NIFE demands
- ◆ Contrast the demand-to-capacity ratios for the structure from the NIFE and LEFE analyses
- ◆ DETAILS ARE IN THE PAPER, and this presentation is a brief summary to excite interest and curiosity about the work

# STRUCTURE GEOMETRY

- ◆ FE analysis performed for three idealized geometries

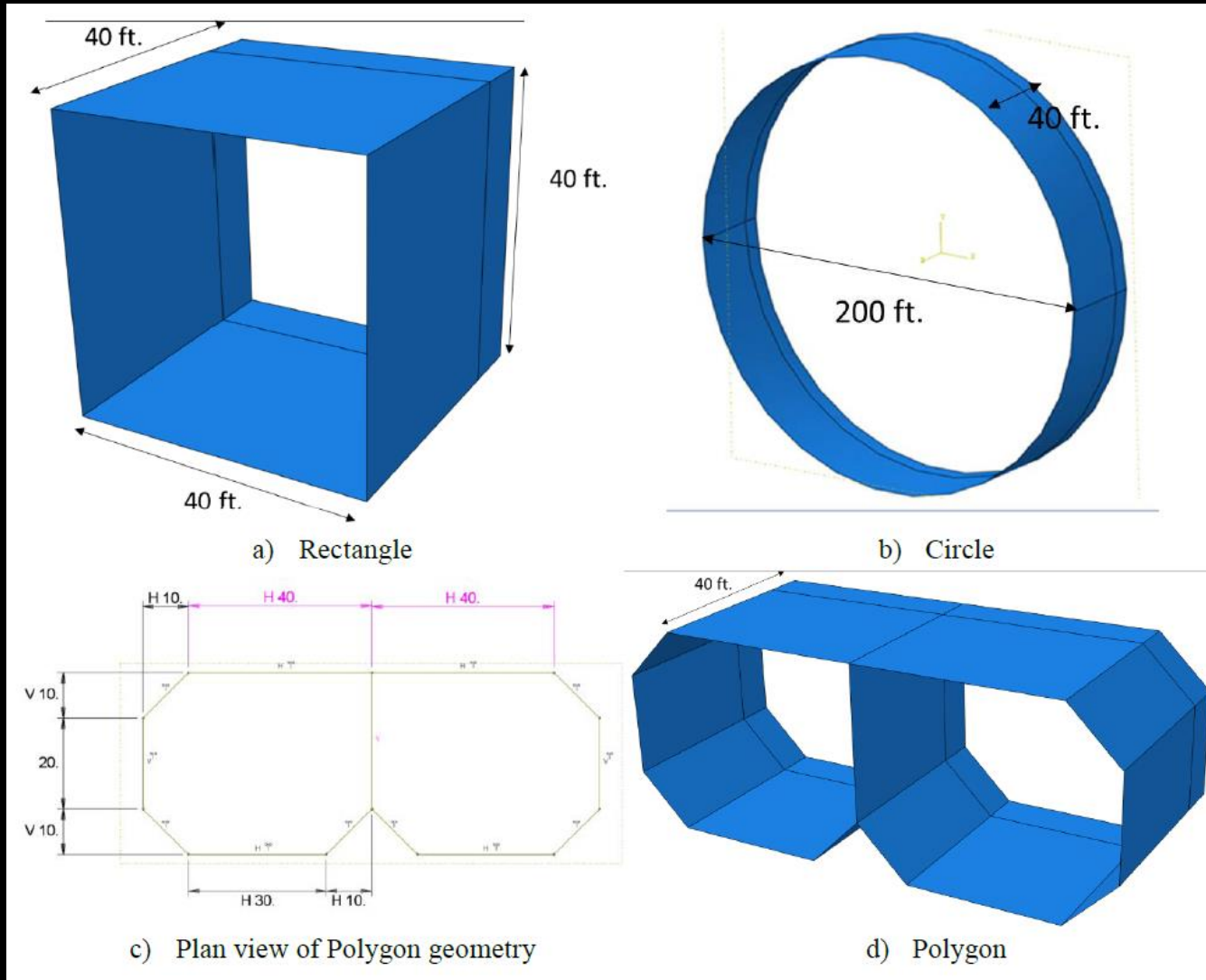

# SIGNIFICANT OUTCOME

- ◆ The results from this study and paper have been used to develop a draft for the next revision of ACI 349.1R (Design for Thermal Loading).
- ◆ The document is being balloted by the committee, and we have a long way to go...
- ◆ But, the work will directly benefit the entire industry for the challenging design situation involving accident thermal loading

