

Building America Case Study

Measure Guideline: Guidance on Taped Insulating Sheathing Drainage Planes

PROJECT INFORMATION

Construction: New and retrofit

Type: Residential

Climate Zones: All

TEAM MEMBERS

Building Science Corporation,
buildingscience.com

BASF, basf.com

The Dow Chemical Company, dow.com

Dupont, dupont.com

CODE COMPLIANCE

International Code Council Evaluation
Service

AC71—Acceptance Criteria for Foam
Plastic Sheathing Panels Used as
Water-Resistive Barriers

The energy efficiency-based financial benefits of adding exterior insulation are well accepted by the building industry, and using exterior insulation as the drainage plane is the next logical step. This case study focuses on the field implementation of taped board insulation as the drainage plane in both new and retrofit residential applications.

To bring together a vast amount of experience, the U.S. Department of Energy Building America team Building Science Corporation interviewed six homebuilders who collectively built more than 27,000 homes in 2011. Most of the contractors and builders agreed that the window, door, and penetration flashing methods and details are already available, and that using the right material and maintaining trade training and supervision were all that was required for success.

Builders have been taping and sealing joints in insulating sheathing for more than two decades. During that time, homebuilders and researchers have developed best practices to tape the remaining joints in the insulating sheathing to create a simple, long-term, and durable drainage plane.

The following are best practice and product recommendations from the interviewed contractors and homebuilders, who identified three significant strategies for successfully using taped insulating sheathing as the drainage plane:

- Limit or eliminate horizontal joints wherever possible.
- Where a horizontal joint exists, use superior materials.
- Require frequent installation inspection and regular trade training to ensure proper installation.

Recommended Taped Sheathing Practices

GOOD — 3–4 in. acrylic tape

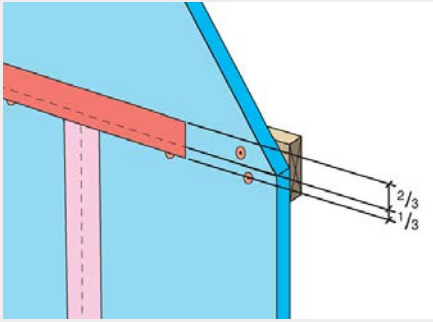

BETTER — 4–6 in. wide butyl tape with 2 in. acrylic termination tape

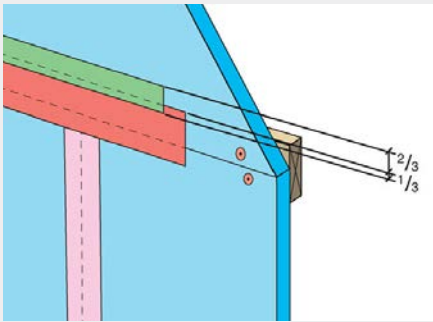

BEST — Butyl Z-flashing with 2 in. acrylic termination tape

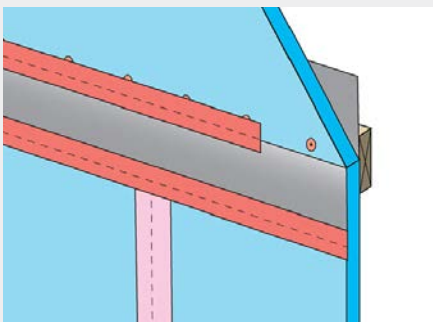

For more Information, see the Building America report, *Measure Guideline: Guidance on Taped Insulating Sheathing Drainage Planes*, at: buildingamerica.gov

Image credit: All images were created by the BSC team.

Progression Summary

Install extruded polystyrene or foil-faced polyisocyanurate insulation following manufacturer's installation instructions.

- 1 Install sill flashings on windows and doors. Sill pan flashings are necessary to ensure proper water redirection to the drainage plane.
- 2 Install flashings on all penetrations. These flashings are necessary to ensure water does not bypass the drainage plane and enter the assembly.
- 3 Install windows and doors. Proper gravity/shingle lapping of the flashing tape around a window installation is important to ensure water does not enter the assembly and that water can get out of the assembly.
- 4 Tape the exterior insulation as the drainage plane, following the tape manufacturer's instructions and the procedures in this document. See drawings at left (Recommended Taped Sheathing Practices).
- 5 Install the exterior cladding of choice according to the manufacturer's recommendations.

Recommendations From the Field

- Drainage planes must be smooth or not significantly textured, clean, dust free, and ideally warm.
- Superior thin tapes are acrylic based, 3–4 in. wide, and should be applied clean, dust free, and ideally warm.
- Superior flashing tapes are butyl based, 4–9 in. wide, 20 mil thick, have a compatible facer, and should be applied clean, dust free, and ideally warm.
- Z-flashings should be used on any high-risk horizontal joint:
 - Butyl-based flashing tapes 6–9 in. wide are preferred
 - No contractor recommends using polyethylene sheet as a Z-flashing.
- Where thick tapes (20-30 mil) are installed horizontally, a termination strip of thin acrylic tape should always be used.
- On horizontal joints, the tape should be offset high; two-thirds of the tape should be on the top board and one-third lapped over the bottom board.
- Backup wood blocking should be installed behind horizontal joint locations to:
 - Provide a backup and stiffness during and after construction
 - Allow the perimeter of the sheet to be fastened properly
 - Provide support during tape installation.
- Vertical joints should be on framing members and be taped with 3–4 in. wide thin tape and gravity lapped with the horizontal joint.