

# SunShot Initiative

## 2014 Peer Review Report

August 2014



## Message from the Director

In 2011, the U.S. Department of Energy (DOE) launched the SunShot Initiative to drive down the costs of solar power to \$0.06 per kilowatt hour by 2020 so that solar can compete with traditional energy generation. To achieve these goals SunShot continually challenges the solar community to develop innovative projects, new solutions, and pursue aggressive research and development targets.

Since its inception, the SunShot Initiative has relied on the expertise of the leaders in industry, academia, and the national laboratories. Before awards are made, the program enlists the help of experts to select projects through a competitive merit review process and then after awards are made for a biannual peer review to assess each project's progress towards the SunShot goals. During both of these times, we rely on experts in the field to provide independent feedback, which is critical to the success of the program.

To independently review the entire SunShot portfolio, the SunShot Initiative held a Peer Review on May 19-22, 2014 in Anaheim, California. The reviewers included leaders in the solar field, members of the National Academy of Sciences, and National Academy of Engineering, as well as senior leaders from Fortune 500 Companies. The reviewers independently reviewed each project to assess how the projects work together to achieve SunShot goals. To ensure the highest level of integrity, the review was conducted independent of program influence, and a third party collected the results for analysis.

I am pleased to share this report, which contains the review results. As you will see in this document, projects focus on different areas of the SunShot mission, and each project plays an important role in achieving that mission. Each project's review scores are consolidated into a summary for each of the five focus areas that make up the SunShot Initiative.

Finally, I would like to extend a very special thank you to each reviewer, awardee, and researcher who participated in the 2014 SunShot Peer Review. This review would not have been possible without everyone's participation.

Thank you,



*Director*

**Solar Energy Technologies Office, SunShot Initiative**  
U.S. Department of Energy

## EXECUTIVE SUMMARY

DOE's Solar Energy Technologies Office (SETO) works to accelerate the market competitiveness of solar energy by targeting cost reductions and supporting increased solar deployment. In 2011, DOE announced the department-wide SunShot Initiative—a collaborative national effort that aggressively drives innovation to make solar energy fully cost competitive (subsidy-free) with traditional energy sources before 2020. In support of this crucial goal, the SETO pivoted its focus to fulfilling the SunShot vision and began continuously evaluating opportunities to further support cost reductions. Through SunShot, DOE supports efforts by private companies, universities, and national laboratories to drive down the cost of utility-scale solar electricity to about \$0.06 per kilowatt hour (kWh) and distribute solar electricity to at or below retail rates.

In May 2014, the SunShot Initiative held a peer review to receive unbiased expertise from industry, government agencies, nonprofit organizations, utilities, and consultants on how each program (Balance of System, Concentrated Solar Power, Photovoltaics, Systems Integration, and Technology to Market) is performing, as well as the SunShot Initiative as a whole. Participating reviewers analyzed, scored, and provided feedback on 251 projects within the SunShot portfolio. These reviewers considered the following questions and directives when evaluating a project:

1. Rate the project's relevance to Program goals.
2. Rate this project's impact to relevant Program goals.
3. How appropriate is the project's funding level compared to the goals of the project?
4. Rate this project's approach(es) to achieve project goals.
5. What are the project's main strengths and weaknesses?

After completing project evaluations, the reviewers divided into groups by program to discuss how projects within their assigned area were performing. A separate group, referred to as the Steering Committee, evaluated

the SunShot Initiative in totality. Specifically, both the separate review groups and the Steering Committee discussed the following questions:

1. How would you rate the quality and impact of the portfolio as a whole for this review area? What are the portfolio's strongest and weakest aspects?
2. Is the portfolio funding properly proportioned relative to the program goals? What areas are not funded sufficiently (if any)? What areas have received too much funding (if any)?
3. How should the portfolio direction or composition shift in the next 2-5 years to continue to lead and advance the field?

All comments from the reviewers and Steering Committee were compiled and then released without attribution in this report. These comments begin on page 14. Each project was ranked on a 1–5 scale, with “5” being the highest possible score for a category and “1” being the lowest possible score. The overall average rating for SunShot's reviewed projects was 3.70, which indicates that the program as a whole is funding projects that wisely use taxpayer dollars and are likely to be successful. The Systems Integration program achieved the highest project rating with a mean of 4.19. The reviewers commended the projects' abilities to fulfill objectives. Conversely, the Photovoltaics and Technology to Market programs had the lowest project averages, with both programs having an average score of 3.47. Both programs are performing above average, but a few low-scoring projects are bringing down the entire average. The Balance of System and Concentrated Solar Power programs had project rating averages of 3.72 and 3.74, respectively. The projects of these two programs are on track to meet their goals and identify paths forward to make them more impactful.

In general, the Steering Committee found that, on the part of Primary Investigators and DOE staff, the motivation exists to achieve the \$0.06 per kWh for utility-scale photovoltaic power and distributed solar electricity to be at or below retail rate goals. Funding is generally well balanced; however, slightly more funding is required for soft costs and public education activities.



---

Steven Bohn, an engineer at SunEdison oversees SunEdison’s testing facility at SolarTAC in Aurora, Colorado. SunEdison is an Original Founding Member of SolarTAC. SolarTAC is an integrated, world-class test facility where the solar industry will test, validate, and demonstrate near-market solar technologies.

# TABLE OF CONTENTS

<b>Message from the Director</b> .....	<b>i</b>
<b>Executive Summary</b> .....	<b>ii</b>
<b>Table of Contents</b> .....	<b>iv</b>
<b>Peer Review Process</b> .....	<b>1</b>
<i>2014 SunShot Peer Review</i> .....	1
<i>Review Questions and Evaluation Criteria</i> .....	3
<b>Overview of the SunShot Initiative</b> .....	<b>5</b>
SunShot Mission and Goals .....	5
<i>Budget</i> .....	6
<i>Programs and Projects</i> .....	6
SunShot Portfolio Review Average, Range, and Standard Deviation .....	7
Steering Committee Report.....	8
<b>Concentrating Solar Power</b> .....	<b>11</b>
CSP Overview.....	12
CSP Portfolio Review Average, Range, and Standard Deviation .....	15
CSP Portfolio Reviewer Report .....	16
<i>Quality and Impact of the Portfolio</i> .....	16
<i>Appropriateness of Funding Relative to Program Goals</i> .....	16
<i>Future Direction and Composition of Portfolio</i> .....	17
<b>Photovoltaics</b> .....	<b>65</b>
PV Overview .....	65
PV Portfolio Review Average, Range, and Standard Deviation .....	68
PV Portfolio Reviewer Report .....	69
<i>Quality and Impact of the Portfolio</i> .....	69
<i>Appropriateness of Funding Relative to Program Goals</i> .....	70
<i>Future Direction and Composition of Portfolio</i> .....	70
<i>Project Description</i> .....	155
<b>Systems Integration</b> .....	<b>159</b>
SI Overview.....	160
Grid Performance and Reliability.....	160
Dispatchability .....	161
Power Electronics .....	161
SI Portfolio Review Average, Range, and Standard Deviation.....	162
SI Portfolio Reviewer Report .....	163
<i>Quality and Impact of the Portfolio</i> .....	163
<i>Appropriateness of Funding Relative to Program Goals</i> .....	163
<i>Future Direction and Composition of Portfolio</i> .....	164

<b>Technology to Market .....</b>	<b>217</b>
T2M Overview.....	217
T2M Portfolio Review Average, Range, and Standard Deviation.....	219
T2M Portfolio Reviewer Report .....	220
<i>Quality and Impact of the Portfolio</i> .....	220
<i>Appropriateness of Funding Relative to Program Goals</i> .....	221
<i>Future Direction and Composition of Portfolio</i> .....	221
<b>Balance of Systems/Soft Costs .....</b>	<b>277</b>
BOS Overview .....	278
Empowering State and Local Leaders.....	279
Harnessing Big Data Analysis and Technical Solutions.....	279
Training a Strong Solar Workforce .....	280
Developing Solar Finance and Business Solutions.....	280
BOS Portfolio Reviewer Report.....	282
<i>Quality and Impact of the Portfolio</i> .....	282
<i>Appropriateness of Funding Relative to Program Goals</i> .....	282
<i>Future Direction and Composition of Portfolio</i> .....	282
<b>Conclusion .....</b>	<b>333</b>
<b>Appendix A: SunShot Initiative Staff.....</b>	<b>335</b>
<b>Appendix B: List of Acronyms.....</b>	<b>337</b>
<b>Appendix C: Endnotes .....</b>	<b>338</b>

---

NREL Senior Scientist Kai Zhu, prepares a dye-sensitized perovskite cell in his lab, using a precursor solution that converts from a liquid base to an absorber in a device.

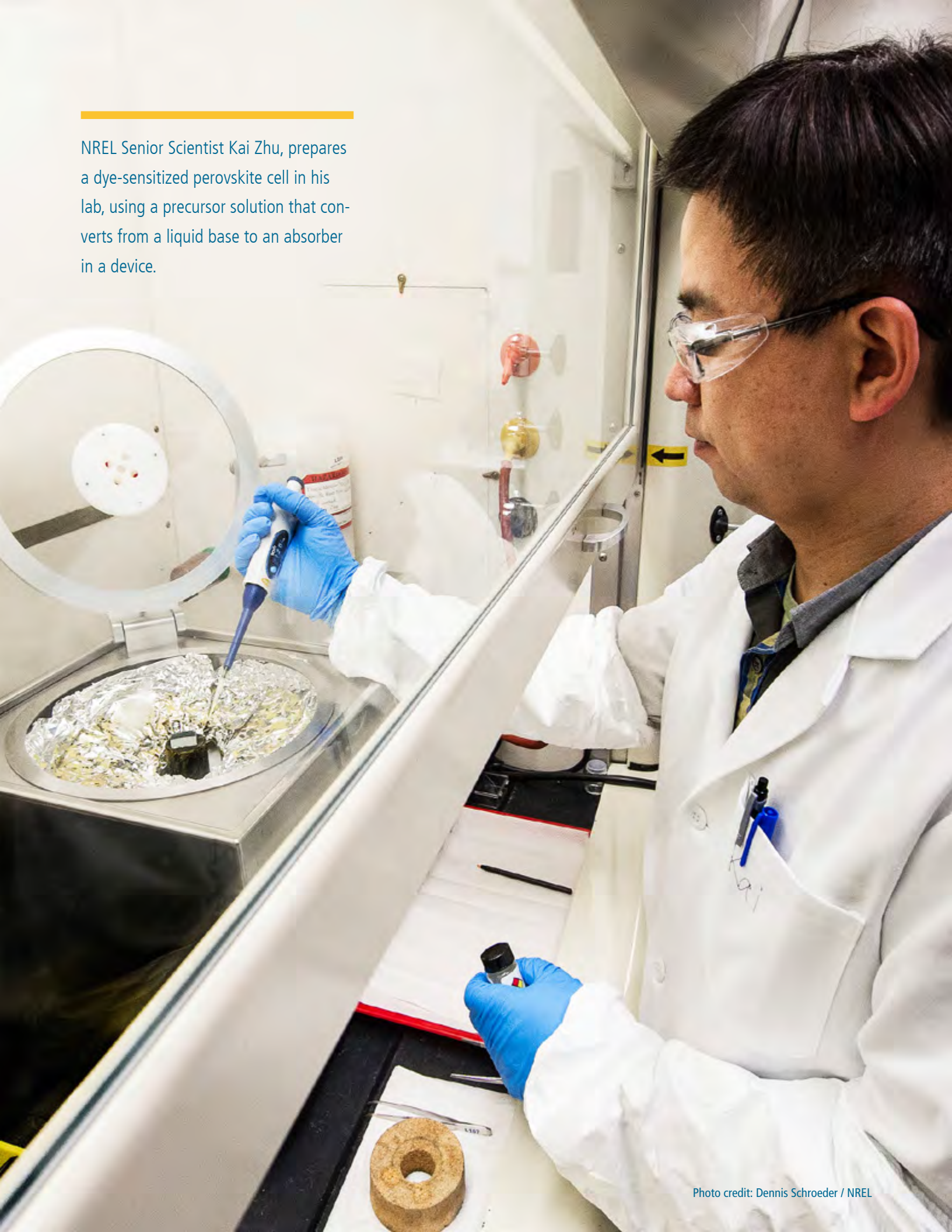



## PEER REVIEW PROCESS

DOE's Office of Energy Efficiency and Renewable Energy (EERE) requires that all offices within EERE participate in program peer reviews approximately every two years. According to EERE, a peer review is a "rigorous, formal, and documented evaluation process using objective criteria and qualified and independent reviewers to make a judgment of the technical/scientific/business merit, the actual or anticipated results, and the productivity and management effectiveness of programs and/or projects."<sup>1</sup> Therefore, it is important that each office within EERE participate in these biannual reviews, as information from these reviews can be used to inform management activities and future merit review processes given the quality and robustness of the feedback provided by a reviewer on an office and its programs.

### 2014 SunShot Peer Review

Conducting a formal peer review is an important process because it informs government agencies of how their programs are performing and whether or not their programs are making effective use of taxpayer money. A peer review also recommends how to make each program more impactful. In May 2014, the SunShot Initiative held a peer review of its project portfolio in Anaheim, California. This peer review was held in conjunction with the SunShot Initiative's *SunShot*

*Grand Challenge Summit*, which highlights successes and sparks meaningful discussion on how to make solar energy fully cost competitive with traditional forms of energy (e.g., coal) by 2020.

The peer review provided an objective third party assessment of SunShot-funded projects to determine their efficacy and impact. Subject matter expert reviewers analyzed, rated, and provided feedback on the 251 projects. This report provides an overview of each reviewed project and contains feedback from the reviewers.

The following table (Table 1) contains a list of reviewers who participated in the 2014 SunShot Peer Review. The first part of the table provides the names and affiliations of the three-person Steering Committee: Elsa Garmire, Bob Schafrik, and Dick Swanson. The Steering Committee was critical to the peer review's success because it collectively provided an objective overview of the entire SunShot Initiative. The second portion of the table includes the reviewers who analyzed individual program portfolios, such as Photovoltaics or Technology to Market. These reviewers represented a variety of domestic and international organizations, including academia (23%) government agencies (10%), consultants (18%), industry (34%), nonprofit organizations (10%), and utilities (5%).

Table 1: 2014 SunShot Peer Reviewers and Institutional Affiliations

Reviewer	Institution
<b>Steering Committee</b>	
Elsa Garmire	Dartmouth College
Robert Schafrik	GE Aviation (Retired)
Richard Swanson	SunPower Corporation (Retired)
<b>Portfolio Reviewers</b>	
Paul Basore	PV Specialist Services
Mariana Bertoni	Arizona State University
Jeff Cotter	Arizona State University
Peter Cousins	SunPower Corporation
Ravi Dixit	Dow Chemical Company
Anne Dougherty	Illume Advising LLC

**Table 1: 2014 SunShot Peer Reviewers and Institutional Affiliations**

<b>Reviewer</b>	<b>Institution</b>
Chris Eberspacher	Independent Consultant
Ed Feo	Coronal Management, LLC
Stephen Forrest	University of Michigan
Charlie Gay	Greenstar Solar Community Center
Markus Gloeckler	First Solar
Ethan Good	SunEdison
William Gould	SolarReserve, LLC
Allen Hefner	National Institute of Standards and Technology
David Hill	Vermont Energy Investment Corporation
Anne Hoskins	Maryland Public Service Commission
Rick Huibregtse	eSolar
Donald Jaworske	National Aeronautics and Space Administration
Terry Jester	Silicor Materials
Anand Kamannavar	Applied Materials
Danny Kennedy	Sungevity
Matt Law	University of California, Irvine
Leslie Libby	Austin Energy
Robert Magnusson	University of Texas at Arlington
Jeff Marqusee	Noblis
Scott Murtishaw	California Public Utilities Commission
Thomas Ortmeyer	Clarkson University
Josh Posamentier	Prelude Ventures
Ryne Raffaele	Rochester Institute of Technology
Veera Rajendran	Rolls-Royce
MJ Shiao	GTM Research
David Sun	Alstom
Rao Surampudi	Jet Propulsion Laboratory
Tom Tibbits	Fraunhofer Institute for Solar Energy Systems
Hamid Toliyat	Texas A&M University
Ray Viskanta	Purdue University
Haiyan Wang	National Science Foundation
Aliza Wasserman	National Governors Association
Claudia Wentworth	Quick Mount PV

## Review Questions and Evaluation Criteria

### *Portfolio Reviewers*

Each portfolio reviewer was assigned about 20 projects to thoughtfully evaluate within his/her respective area of expertise. The format of the review process was as follows:

First, the reviewers received technical summaries and posters for each project two weeks before the review. These documents provided the reviewers with pertinent project information, including project title, organization of prime awardee, project description (background, approach, objectives, milestones, key findings, outcomes, and next steps), and funding levels. The reviewers were encouraged to read this information before the in-person peer review.

During the review, the Principle Investigator (PI) for each project provided a 15-minute presentation on his/her SunShot-funded activity. Each presentation allowed reviewers to ask questions that originated during their initial review of the technical summary and poster, as well as those that arose during the presentation.

The reviewers then scored the projects and provided a qualitative justification for their ratings. They responded to the following questions and directives:

1. Please rate the project's relevance to Program goals (1–5 scale with 3 being average, 1 least and 5 most relevant).
2. Please rate this project's impact to relevant Program goals (1–5 scale with 3 being average, 1 least impact, and 5 greatest impact).
3. How appropriate is the project's funding level compared to project goals? (1–5 scale with 3 being average, 1 least appropriate, and 5 most appropriate)
4. Please rate this project's approach (es) to achieve the goals of the project (1–5 scale with 3 being average, 1 least effective, and 5 most effective).
5. What are the main strengths and weaknesses of this project? (qualitative)

Each of the first four questions and directives were weighted evenly (25%). In this report, the author edited reviewers' inputs for grammar and context the comments regarding Question 5 on project strengths and weaknesses.

After meeting with the PIs for their assigned projects, the portfolio reviewers met in their groups (Balance of System, Concentrated Solar Power, Photovoltaics, Systems Integration, or Technology to Market) to collectively answer the following qualitative questions:

1. How would you rate the quality and impact of the portfolio, as a whole, for this review area? What are the strongest and weakest aspects of the portfolio?
2. Is the portfolio funding properly proportioned relative to the program goals? What areas are not funded sufficiently (if any)? What areas have received too much funding (if any)?
3. How should the portfolio direction or composition shift in the next 2-5 years to continue to lead and advance the field?

The responses for these questions can be found in the respective portfolio areas.

### *Steering Committee*

In order for the Steering Committee to provide an evaluation of the SunShot Program, each reviewer was given access to all of the project summaries and posters. Additionally, each reviewer was given the freedom to speak with individual PIs and project partners during the Technology Forum and Poster Session. The Steering Committee was then asked to collectively answer the same qualitative questions as above. The Steering Committee's response is presented in the following Steering Committee Report section.



---

Alamosa Solar Generating Project is the largest high concentrating solar photovoltaic power generation system in the world. Alamosa Solar consists of over 500 dual-axis, pedestal mounted tracker assemblies, each producing 60 kW. Each tracker assembly is 70 ft. wide by 50 ft. high and contains 7,560 fresnel lenses that concentrate sunlight by a multiple of 500 onto multi junction cells.

## OVERVIEW OF THE SUNSHOT INITIATIVE

Widespread solar energy deployment can strengthen U.S. economic competitiveness in the global clean energy race, help cut carbon pollution to combat climate change, and secure America's energy future. The United States has enormous potential to get its energy from the sun; photovoltaic (PV) panels on just 0.6% of the nation's total land area could supply enough electricity to power the entire United States.<sup>1</sup> PV can also be installed on rooftops with essentially no land-use impacts. Seven southwestern states have the technical potential and identified land area to site enough concentrating solar power (CSP) to supply more than four times the current U.S. annual demand.<sup>2</sup> Further, as a domestic energy source, solar supports broader national priorities, including national security, economic growth, and job creation.

Energy captured from the sun is more affordable, accessible, and prevalent in the United States than ever before. In 2012, rooftop solar PV panels cost about 1% of what they did 35 years ago. Since the beginning of 2010, the average cost of solar PV panels has dropped more than 60%, and the cost of a solar electric system has dropped by about 50%. Markets for solar energy are maturing rapidly around the country, and solar electricity is now economically competitive with traditional energy sources in several states, including California, Hawaii, and Minnesota. Moreover, the solar industry is a proven incubator for job growth throughout the nation. Solar jobs have increased by nearly 20% since the fall of 2012, which is 10 times the national average job growth rate. There are more than 142,000 solar workers in the United States, and each day the solar industry creates 56 new jobs across the country.<sup>3</sup>

In 2013, solar energy reached a significant milestone: more than 1% (13 gigawatts) of the nation's electricity generating capacity is now powered from the sun. This is a vast increase from 2008, when solar generation was less than 0.1% of the nation's electricity capacity.<sup>4</sup> Yet significant work remains before solar achieves grid parity and realizes its full potential throughout the country. Solar hardware costs have fallen dramatically, but market barriers and grid integration challenges continue to hinder greater deployment. Non-hardware solar "soft

costs"—such as permitting, financing, and customer acquisition—are becoming an increasingly larger fraction of the total cost of solar and now constitute up to 64% of the cost of a residential system.<sup>5</sup> Technological advances and innovative solutions are needed to increase module and process efficiencies, drive down costs, and enable utilities to rely on solar for baseload power.

The SunShot Initiative is designed to establish American technological and market leadership in solar energy, diversify the nation's electricity supply, reduce the environmental impacts of electricity generation, strengthen U.S. manufacturing competitiveness, train the next generation of the solar workforce, and catalyze domestic economic growth. The SunShot Vision Study, a guiding document for the Initiative's work, estimates that meeting SunShot cost reduction goals would allow solar to scale rapidly and potentially generate up to 14% of the nation's total electricity demand by 2030 and 27% by 2050.<sup>6</sup>

### SunShot Mission and Goals

Through game-changing innovations, SunShot's nearly \$900 million in investments over the last 3 years are transforming how solar systems are conceived, designed, manufactured, and installed in order to make it faster, easier, and cheaper to deploy solar. SunShot has funded hundreds of projects that are making solar more affordable and accessible—from streamlining panel manufacturing processes to reducing the red tape involved with permitting a residential solar energy system.

Only 3 years into DOE's decade-long SunShot Initiative, the solar industry is already more than 60% of the way to achieving SunShot's cost target of \$0.06 per kilowatt-hour (kWh) for utility-scale PV (based on 2010 baseline figures),<sup>7</sup> and more than halfway to CSP cost targets.<sup>8</sup> Since SunShot's inception, the average price per kWh of a utility-scale PV project has dropped to \$0.11 from about \$0.21, the levelized cost of electricity for CSP has decreased to \$0.13 from about \$0.21,<sup>9</sup> and solar jobs have grown by 53%.<sup>10</sup>

SunShot's success is a shining example of how government and industry can partner to move markets and grow our economy. SunShot's investments are paying dividends for domestic clean energy, while helping to prevent carbon emissions. Today, as a result of the U.S.

Department of Energy's (DOE's) SunShot Initiative investments and the industry's accelerated pace to meet SunShot goals, the cost of going solar continues to drop, and more solar is being added to our nation's energy mix.

While the solar industry has made significant progress only 3 years into the SunShot Initiative, grand challenges remain. The final 40% cost reduction to achieve the SunShot goal will require the most game-changing ideas and cutting-edge technological developments—from harnessing the power of big data, to developing innovative financing mechanisms and more streamlined and efficient manufacturing processes. As SunShot continues to support innovative technical and market solutions to reduce the costs of solar, the Initiative will help to enable a world where homes, workplaces, and communities are powered by clean, renewable energy; utilities can count on solar to provide baseload power; and ubiquitous and cost-effective solar energy helps cut carbon pollution and fight climate change.

## Budget

SunShot funding programs target technical and market barriers for solar energy. To develop new funding programs, SunShot holds idea development sessions across teams to ensure cross-pollination between program focus areas and support the development of holistic approaches to tackling major challenges. The most promising topics are identified through internal debate and rigorous review by all SunShot program managers. SunShot also gathers industry experts at technical workshops to provide feedback on targeted barriers and potential solution pathways; the Initiative also solicits broad input from stakeholders. Based on stakeholder feedback, some of the ideas discussed at workshops may eventually be incorporated into funding programs, while others may not. As part of the rigorous review for new funding programs, SunShot staff debate and refine potential topics and justify new programs with a set of criteria issued by the Office of Energy Efficiency and Renewable Energy (EERE).

Once a funding program is created, a solicitation or funding opportunity announcement (FOA) is publicly issued to the stakeholder community to solicit applications. Each application is subjected to a rigorous review process, including evaluation by an external peer review

panel consisting of distinguished scientists, engineers, and practitioners from academia, industry, and national laboratories across the nation. Based on the rigorous technical review process, the alignment of the application to SunShot goals, and the availability of funding, awards are made to the top few applications in any given funding program.

Once awards are made, SunShot team members actively manage projects through the length of the award agreement to ensure awardees meet agreed-upon project objectives, deliver on milestones, and yield valuable results. Post-award workshops and other SunShot events, including the biennial SunShot Grand Challenge Summit and Peer Review, connect awardees and other leaders doing innovative work in solar energy—furthering the spread of ideas and the spread of ideas and best practices within the SunShot community.

## Programs and Projects

Modeled after President John F. Kennedy's Moonshot goal to place a man on the moon in the space of a decade, SunShot is an aggressive, goal-driven national initiative. SunShot targets call for solar cost reductions of 75% relative to 2010 baseline levels. As such, the SunShot approach targets significant technological and market advancements that are needed to achieve grid parity by 2020. SunShot promotes market competitiveness with cost-based metrics, aiding the spread of technology and process innovations and enabling rapid growth in solar energy deployment.

Within SunShot, dedicated teams work on each of the Initiative's five focus areas: PV, CSP, systems integration, technology to market, and soft costs.

- **PV and CSP:** SunShot funding supports transformative PV and CSP technology research and development (R&D) with the potential to yield significant cost reductions, efficiency improvements, and improved reliability standards. SunShot also supports the development of next-generation PV technologies to carry innovation in solar energy beyond 2020, as well as CSP thermal energy storage technologies that can provide dispatchable power generation and enable greater deployment of other renewable energy sources.

- **Systems Integration:** Systems integration funding supports strategies to dramatically increase solar penetration in the nation’s electrical grid and enable safe, reliable, cost-effective, and widespread solar deployment.
- **Technology to Market:** Technology to market funding supports commercialization, market readiness, and domestic manufacturing supply chains. Small solar businesses selected to participate in SunShot’s competitive Incubator program have earned more than \$18 in follow-on funding for every \$1 in government investment. The success of this program has spurred similar efforts throughout EERE.
- **Soft Costs:** While recent technological advances have drastically reduced the cost of solar hardware, making soft costs a greater share of the overall cost of solar, SunShot soft costs funding supports market transparency, workforce training, local solutions, and process improvements to make solar deployment faster, easier, and cheaper.

Since 1978, DOE has supported the research, development, and deployment of a diverse array of energy technologies. These efforts have reduced the cost of these technologies and helped to improve the safety and reliability of the electrical grid. Within the Department, SunShot’s work supports applied projects that target cost effective solutions to technological and market barriers, filling an important niche. SunShot coordinates its activities with the DOE Office of Science and the Advanced Research Projects Agency–Energy (ARPA–E) to

prevent duplication of efforts while maximizing department-wide impact on solar energy. SunShot supports the Department’s broader Clean Energy Manufacturing Initiative to increase the efficiency of the U.S. manufacturing sector and ensure that clean energy technologies continue to be made in America. SunShot also supports foundational research that is crucial to the advancement of solar energy technologies at the national laboratories and at user facilities that provide critical capabilities to the American solar industry.

## SunShot Portfolio Review Average, Range, and Standard Deviation

The scores from all 251 projects reviewed during the 2014 SunShot Peer Review were tabulated and analyzed

to provide the following information on the overall SunShot Portfolio. Projects were ranked on a 1–5 scale, with “1” being the lowest possible score for a category and “5” being the highest score. For the entire SunShot portfolio, the overall average rating was 3.70. Of the 251 projects, 136 were performing above the mean, while 115 achieved scores that were lower than the 3.70 average. The range of overall scores was 3.00, with a median of 3.75, mode of 4.00, and standard deviation of 0.51. This information is presented in Table 2 and Figure 1. Overall, the data have a skewness of -.57 and are skewed to the left, as the mean is smaller than the median, and the median is smaller than the mode.

Table 2: SunShot Portfolio Review Average, Range, and Standard Deviation

	Average	Range		Standard Deviation
Relevance	4.06	2.00	5.00	0.65
Impact	3.53	1.33	5.00	0.66
Funding	3.54	1.67	4.67	0.59
Approach	3.67	1.67	5.00	0.66
Overall	3.70	1.84	4.84	0.51

Figure 1: Frequency of project rating for SunShot portfolio

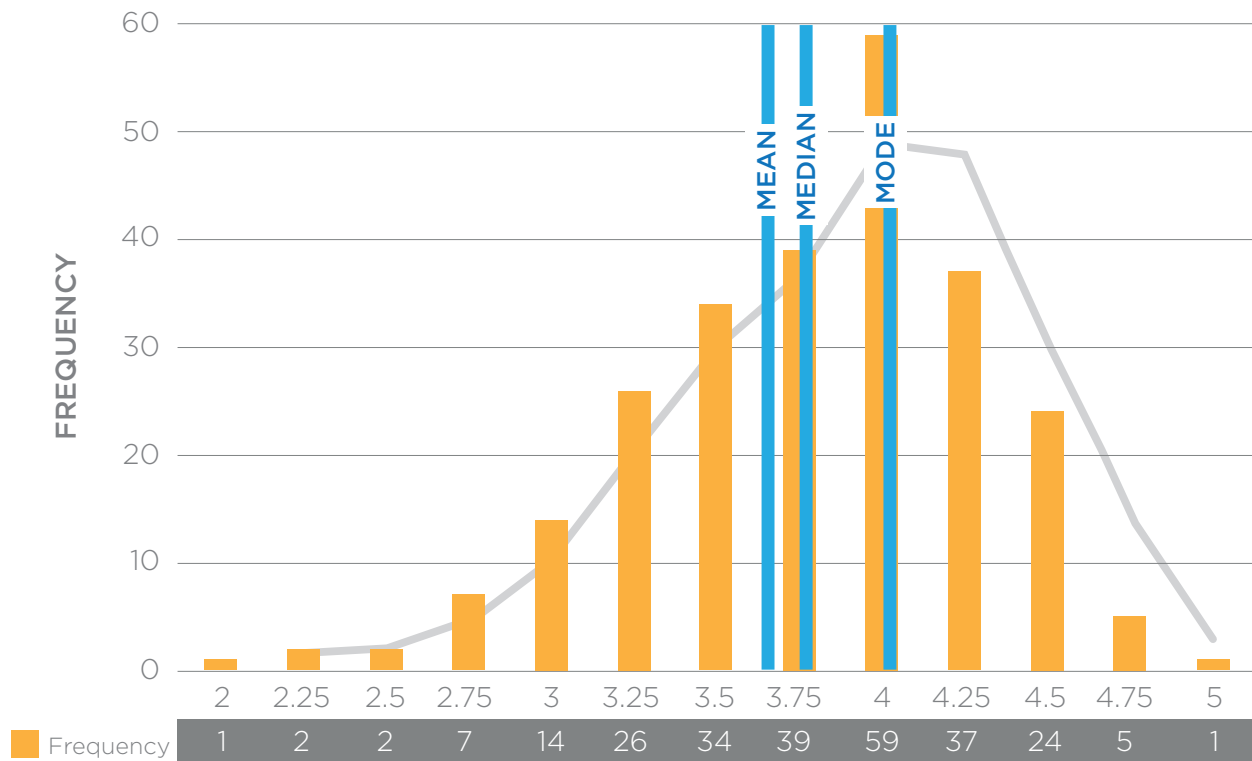

## Steering Committee Report

The following section contains the evaluation of the overall SunShot portfolio, as analyzed by the Steering Committee. To preserve the integrity of the Committee’s response, the analysis is provided almost verbatim, with minor edits for grammar.

### How would you rate the quality and impact of the portfolio as a whole for this review area? What are the strongest and weakest aspects of the portfolio?

First, we would like to say that the energy level, enthusiasm of the DOE team, and focus of nearly all the projects on the twin goals of initial cost at \$0.06 per kWh and 30-year life are really impressive. The management seems to be highly involved in program development and monitoring. From our perspective, it is very impressive how the program has pivoted beyond just PV modules to include soft costs, tech-to-market issues, and CSP. These are hugely important to the industry. What makes this all the more impressive is that it initially may not have been obvious or clear how DOE could contribute in these areas. The new programs have responded by being wonderfully innovative and dynamic (a really impressive shift).

The legacy of poor PV support since 1984 means that university programs have an uphill climb to reach full productivity. The recently renewed support for university programs will pay dividends over time as groups get more experience with industry needs. Continuity of research support is important, both to enable Ph.D. students to finish their research and for the impacts of research results to be fully recognized.

We would reduce (not eliminate) the emphasis, however, on funding start-up companies and increase support for the existing market players. This is because of the long, difficult road ahead in commercializing energy infrastructure. In this regard, the new SolarMat program is welcome.

### Is the portfolio funding properly proportioned relative to the program goals? What areas are not funded sufficiently (if any)? What areas have received too much funding (if any)?

We find the portfolio well balanced among CSP, PV, Soft Costs, and Market Development. It is also well balanced within PV between crystalline silicon, thin films, and



emerging materials. If any correction is warranted, it would be to increase the soft cost and public education activities. In addition, more attention should be given to the architectural attractiveness of PV systems (specifically residential), varieties in materials and processes that affect material durability, and having a strategy to work with the science base to support engineering reliability assessments and development of meaningful component acceptance tests. The crucial importance of battery development is understood; while it may not be in the SunShot program, continuing close contact with research in this area is required and can be facilitated by joint funding of some programs.

### How should the portfolio direction or composition shift in the next 2–5 years to continue to lead and advance the field?

We believe that DOE needs to wrestle with the following topics and issues:

- What should be the relative emphasis in the portfolio on breakthroughs and fundamentals versus incremental improvements? This must take cognizance of the fact that energy technologies are inherently capital and infrastructure intensive and hence change slowly. Thus, most breakthroughs take long to have a market impact. This is particularly true since, at present, no PV material stands out as clearly the optimum choice. Somehow the program needs to find the right balance, somewhere between incremental improvements that may best be left to industry and blue sky innovation that will not have impact for decades, which is better left to the science funding agencies. The U.S. government laboratories will be most valuable where they have unique capabilities to offer that do not reside in universities or industry. Collaborations between all three sectors are likely to have the largest impact.
- For manufacturing, the issues in bringing it to the United States are largely societal and industrial policy driven, such as taxes, capital availability, trained workforce, local market size, and the like. Not many of these levers are available to DOE. While it is clear that DOE must represent the U.S. taxpayers, too much emphasis on U.S. manufacturing at the expense of developing a local PV market with its inherently local non-module job creation, will be counterproductive. It doesn't resonate well with global companies in our current market envi-

ronment. There will likely be a substantial role for U.S.-designed integrated PV power systems, where a considerable amount of work continues to be required to solve the multitude of unresolved issues as PV continues to penetrate power systems.

- The issue of reducing CapEx is very important to the future of the PV industry, as it limits manufacturing growth. We are not sure how SunShot can best address that, but some emphasis on innovation in manufacturing equipment would be welcome. This aspect also plays into improved prospects for U.S. manufacturing if the tool knowhow is located in the United States.
- Since the major technical issues in PV relate to reducing cost, we suggest better integration of the NREL cost analyses into the proposal announcements and submission requirements so that principal investigators are induced to wrestle with the cost-reduction potential of their proposed research.
- We suggest better linking of results from the high-penetration studies to provide input and direction for program design.
- While the \$1/W goal is intuitive and catchy, we suggest having additional sub-goals, including leveled cost of energy (LCOE) and renewable penetration (which is after all the overall desire).
- Along those lines, it may be time to create a renewable roadmap that includes cost and penetration goals.
- SunShot should consider sponsoring a workshop on reliability. The workshop would focus on pre-competitive issues that affect durability and reliability over the projected 30-year lifespan of CSP and PV systems. A key goal would be development of standards based on science as opposed to screening tests that may or may not be related to key underlying degradation modes but exist for historical reasons. A workshop under joint DOE and National Institute of Standards and Technology sponsorship would be ideal.

Beyond these programmatic issues, we see a need for broad education of general public on the existential threat to our way of life in order to create broad public support for renewables, as was done with the original Moonshot. This could include more on how to evaluate locally the monetary value of investing in PV over the long term, to encourage further market penetration.



REC Solar employees Brian Webster, left and Mario Richard, right, install PV modules on a Englewood, Colorado home participating in the Solar Benefits Colorado program.

Photo credit: Dennis Schroeder / NREL

## CONCENTRATING SOLAR POWER

The solar field comprises up to 40% of the total system costs for CSP technologies. The SunShot CSP program seeks to dramatically reduce the cost of the solar field while improving optical accuracy and ensuring durability. In order to accomplish these goals, SunShot supports R&D efforts to develop high optical accuracy reflectors; reduce collector structure weight and material; develop lean and rapid methods for manufacturing, assembly, and installation; develop highly efficient tracking and control methods, as well as accurate metrology tools; and reduce collector soiling and the water required for operations and maintenance.

SunShot technical targets for the solar field:

- Cost <\$75/m<sup>2</sup>
- Optical error <3 mrad
- Sustain wind speed >85 mph
- Lifetime >30 years

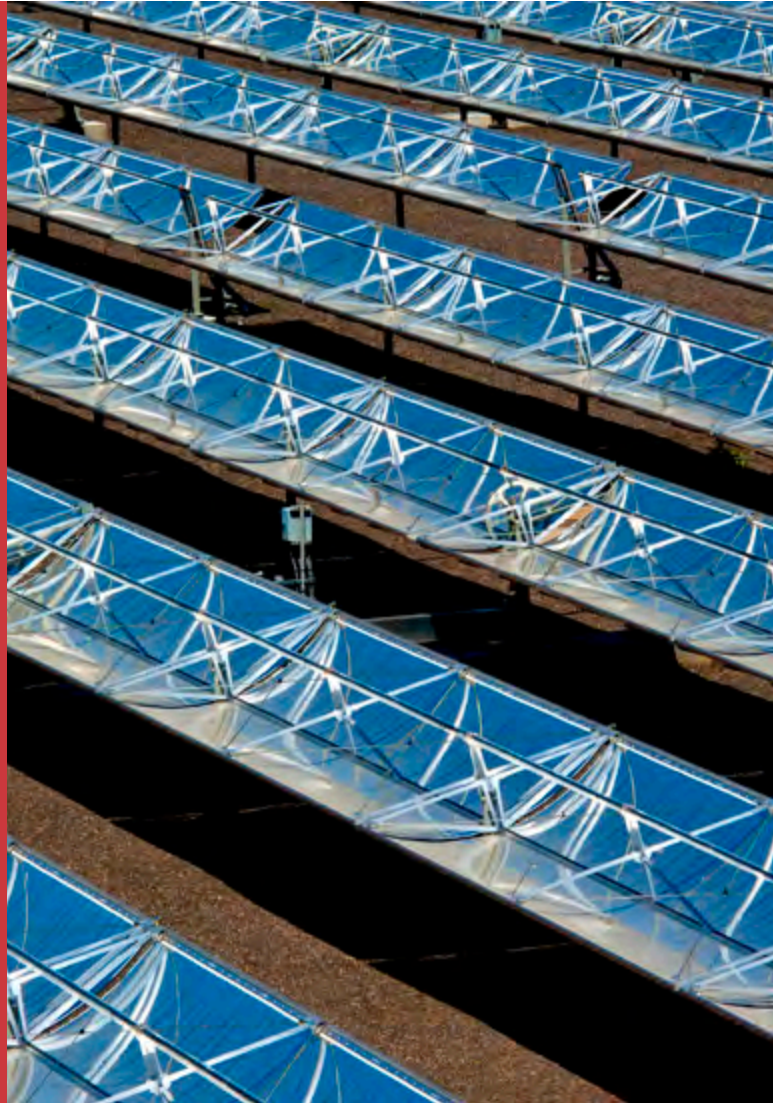

The Red Oak Park a neighborhood in Boulder, Colorado features renewable energy design.

Photo credit: Dennis Schroeder / NREL

CSP technologies use mirrors to focus and concentrate sunlight onto a receiver, from which a heat transfer fluid carries the intense thermal energy to a power block to generate electricity. A distinguishing feature of CSP is its ability to incorporate simple, efficient, and cost-effective thermal energy storage by virtue of converting sunlight to heat as an intermediate step to generating electricity. In addition to providing dispatchable power generation,

CSP with thermal energy storage can also enable greater incorporation of other variable generation sources, such as PV and wind on the grid. Furthermore, CSP systems can synergistically integrate with fossil-fueled power plants to offset fuel use and reduce carbon footprints. CSP, therefore, presents unique opportunities for the renewable energy space and is a key enabling technology in the nation's all-of-the-above energy strategy.

Figure 2: SunShot Initiative 2020 goal for concentrating solar power and the cost reductions achieved from 2010–2013

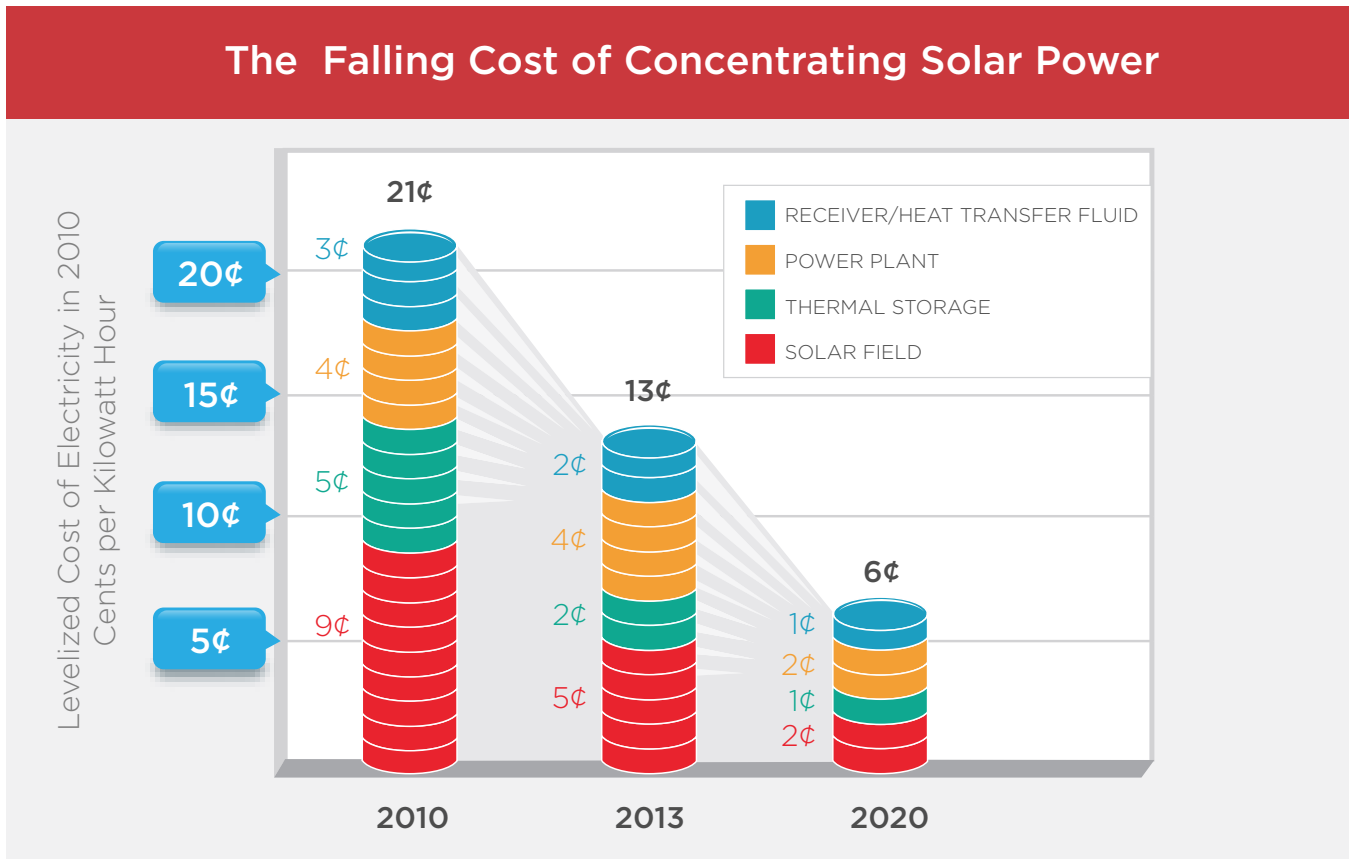

## CSP Overview

CSP technologies are deployed primarily in four system configurations: parabolic trough, linear Fresnel, dish engine, and power tower. Parabolic trough and linear Fresnel systems focus sunlight onto a linear receiver, whereas dish engine and power towers focus sunlight

onto a single central receiver. These system configurations include collectors (solar field), receivers, power block (power plant), and thermal energy storage subsystems. The SunShot Initiative goal for CSP translates to achieving a subsidy-free LCOE of \$0.06/kWh or less by the end of the decade.

Figure 3: Technical metrics and cost targets for CSP subsystems to achieve an LCOE of \$.06/kWh, and the subsystems addressed by the funding opportunity announcements released

## Deconstructing 6¢/kWh

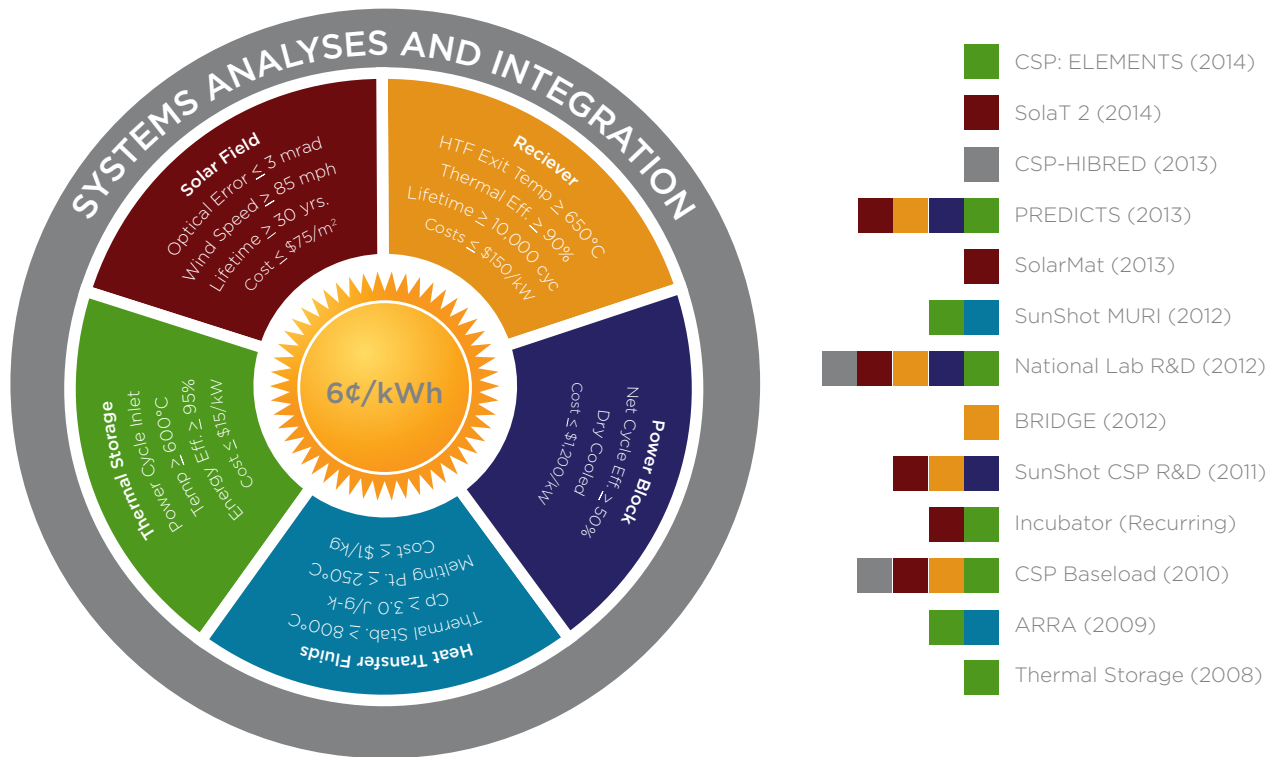

Toward this objective, Figure 2 shows the cost reductions that are targeted in the various subsystems relative to their costs at the beginning of the decade. It is evident that these reductions represent an aggressive challenge that calls for significant technical advancements in performance and efficiency. The LCOE target of \$.06/kWh may be mapped using a technoeconomic analysis to the performance and cost targets for each of the subsystems, as depicted in Figure 3. In general, the targets require higher temperature operation at higher

efficiency, longer lifetime, and lower cost. These target metrics are the basis for the competitive funding opportunity announcements of the SunShot CSP program. The program provides funding—all through competitive awards—to industry, national laboratories, and universities (Figure 4) to develop component technologies and systems solutions to achieve the technoeconomic goals of the SunShot Initiative. Since the launch of the Initiative in 2011, about \$145 million has been committed for developing CSP technologies to meet SunShot goals.

Figure 4: CSP R&D portfolio funding distribution among industry, national laboratories, and universities in fiscal year 2013

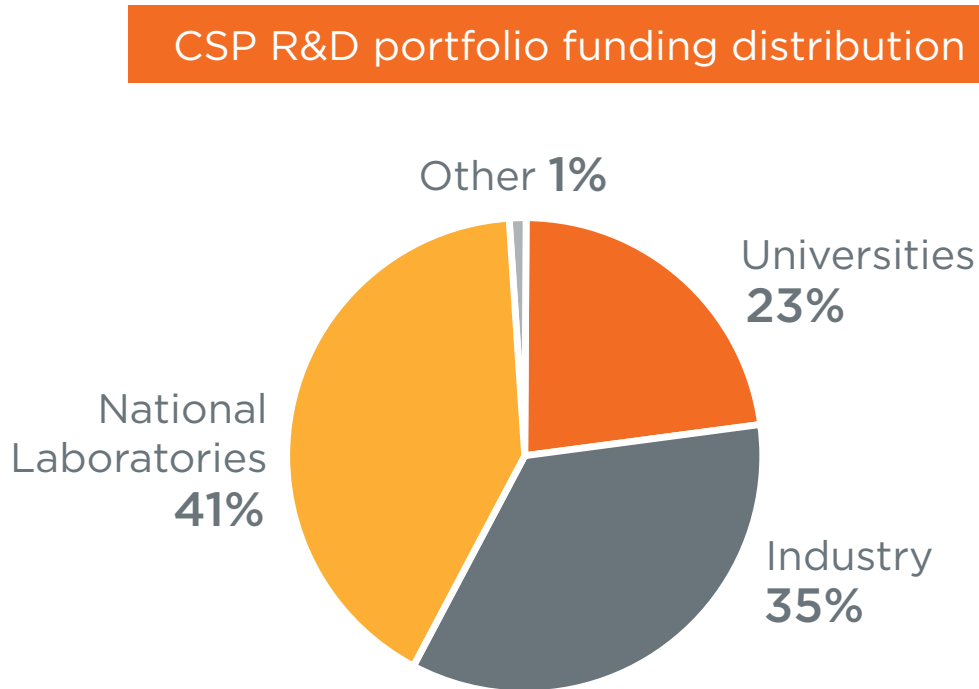

Awarded projects are selected through a rigorous peer review process and are actively managed with defined quantitative and measurable milestones, deliverables, and periodic stage gates with go/no-go criteria. Much emphasis is placed on understanding the fundamentals to drive innovation and technological advances at the component and system levels, with a steadfast focus on driving down costs.

The current portfolio of projects includes investments with near-term to long-term horizons that span all of the various CSP technologies. Ongoing R&D efforts aim to deliver transformative technologies within the next three to five years. These include highly efficient reflector materials integrated with low-cost collector structures, lean solar field manufacturing and assembly approaches, self-aligning and tracking controls, self-cleaning mirrors, novel receiver designs, solar selective coatings for enhanced collection efficiency, corrosion-resistant materials and coatings, viable heat transfer fluids to carry the heat from the receivers for

high-temperature operation, and cost-effective thermal energy and thermochemical energy storage technologies. High-temperature, higher-efficiency power cycles such as the supercritical carbon dioxide Brayton cycle demonstrated at the 1–10 MW scales, as well as the solar integrated air Brayton cycle, will also be very significant. These next-generation power cycle technologies have broader relevance beyond the solar industry to the nuclear, fossil, and geothermal industries, among others. In addition, an award as part of the CSP-HIBRED (Heat Integration for Baseload Renewable Energy Development) funding opportunity seeks to catalyze near-term demonstration of hybrid power systems that integrate CSP with fossil-powered plants.

Just two years into the SunShot Initiative, DOE’s investments at the national laboratories, industry, and universities are beginning to pay off. Based on 2013 figures, the LCOE for CSP is \$0.08/kWh less than what it was in 2010 (Figure 2)—that is over the halfway mark in the reductions needed toward the SunShot target. While the

initial reduction is impressive, much remains to be done as we continue to work toward the goal of subsidy-free cost parity of CSP-generated electricity on the grid.



**Dr. Ranga Pitchumani**

*Chief Scientist and  
Program Manager*  
Solar Energy  
Technologies Office  
U.S. Department of Energy

### Team Members

Christine Bing, Technical Project Officer

Edward Hoegg, SunShot Fellow

Levi Irwin, SETA

Mark Lausten, SETA

Candace Pfefferkorn, AAAS Fellow

Andru Prescod, SETA

Tommy Rueckert, Technical Project Officer

Avi Shultz, SunShot Fellow

## CSP Portfolio Review Average, Range, and Standard Deviation

Of the 251 projects in the SunShot Portfolio, 44 projects were reviewed as part of the CSP portfolio review. Each reviewed project is listed on Table 4. Projects were ranked on a 1–5 scale, with “1” being the lowest possible score for a category and “5” being the highest score. Reviewers provided overall ratings on each project’s relevance to the SunShot and CSP portfolio mission and goals, overall impact, level of funding, and approach taken.

For the CSP portfolio, the overall average rating for a project was 3.74. Of the 44 projects, 25 were performing above the mean, while 19 achieved scores that were lower than the 3.74 average. The range of overall scores was 1.25, with a median of 3.83, mode of 4.09, and standard deviation of 0.35. This information is presented in Table 3 and Figure 5. The reviewers’ comments on the program as a whole are provided in the following sections. Overall, the data have a skewness of  $-.57$  and are skewed to the left, as the mean is smaller than the median and the median is smaller than the mode.

**Table 3: CSP Portfolio Review Average, Range, and Standard Deviation**

	Average	Range		Standard Deviation
Relevance	4.25	3.00	5.00	0.64
Impact	3.43	2.00	4.00	0.46
Funding	3.70	2.67	4.33	0.49
Approach	3.57	2.67	4.33	0.43
Overall	3.74	3.00	4.25	0.35

Figure 5: Frequency of overall project rating for CSP portfolio

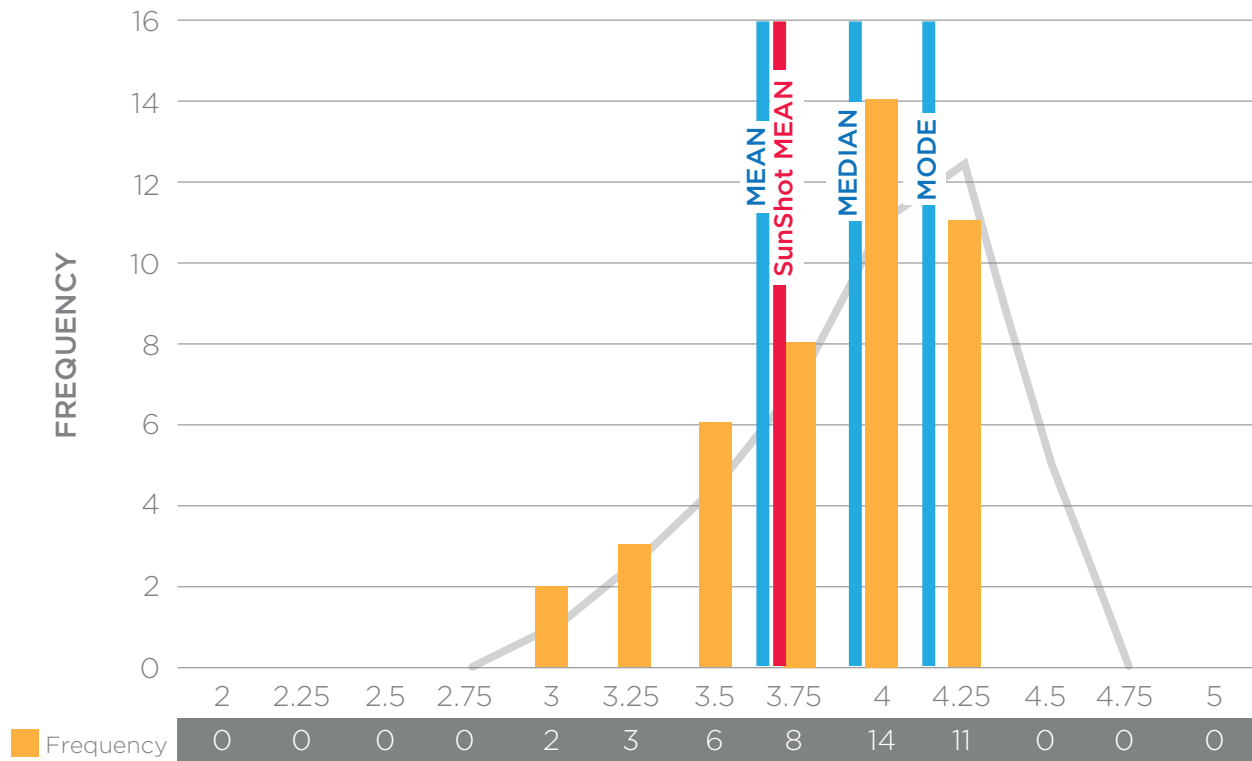

## CSP Portfolio Reviewer Report

The following section contains the evaluation of the Concentrating Solar Power portfolio, as analyzed by the reviewers assigned to the CSP portfolio. To preserve the integrity of the reviewer’s responses, the analysis is provided almost verbatim, with minor edits for grammar.

### Quality and Impact of the Portfolio

The overall quality of the technical work in the CSP portfolio is very strong, though the potential for impacts in the near-term perspective (identified as the 2014–2020 timeframe) is inadequate to achieve the goals of the SunShot Initiative and CSP portfolio. The long-term impact of the activities in the CSP portfolio (identified as the 2024 timeframe and beyond), however, are very strong; this can be attributed to several longer-term projects that focus on R&D activities.

It is important to note that some of the project teams in the CSP portfolio may not have sufficient technical expertise to accomplish their project goals. DOE needs to be sensitive to this issue and ensure that all project

teams have sufficient technical expertise as necessary and expected.

### Appropriateness of Funding Relative to Program Goals

General comments and opinions on the appropriateness of funding relative to the CSP portfolio goals were not documented, but noted that the following project areas are not funded sufficiently in the current project portfolio:

- Electrical power and networking
- Land preparation and civil work for CSP in-field hardware
- In-field cleaning of solar equipment (the actual cleaning process as opposed to films or reduction)
- Component and subcomponent design (e.g., heat exchangers or compressors)
- Systems integration for CSP plant hybridization (e.g., fossil, biomass, or thermoelectric storage)
- Part and sub-system standardization.



Conversely, two areas were identified as likely receiving too much funding: (1) the development of manufacturing equipment for specific reflector designs and (2) thermochemical storage and recovery. In terms of thermo-electric storage, concerns on overfunding were partially mitigated given sensitivity on the behalf of the reviewers to the importance of thermal energy storage for achieving CSP program goals.

## Future Direction and Composition of Portfolio

The portfolio will be better balanced with the inclusion of additional or more substantial work by building on to the areas previously identified as being underfunded. This includes the development of improved electrical power and networking infrastructure, expertise in land

preparation, civil engineering work in CSP, in-field hardware assembly and maintenance, cleaning processes to support in-field cleaning of solar equipment, standardization of parts and sub-systems, improved and innovative design of component and subcomponent technologies, the development of systems integration methods, the demonstration of results beyond models by scalable prototypes and pilot systems, and expertise for CSP plant hybridization.

Finally, separate groups that are working on common technologies, subsystems, and systems could benefit from more robust coordination (e.g., falling particle receivers, supercritical CO<sub>2</sub> power cycle, heat transfer fluids and corrosion, and thermochemical reactor designs).

Table 4: Projects Reviewed under Concentrating Solar Power Program

Award Number	Project Name	Project Organization
772	SMUD CSP HIBRED Project	Sacramento Municipal Utility District
1533	Engineering a Novel High-Temperature Metal Hydride Thermochemical Storage	Pacific Northwest National Laboratory
1541	High-Performance Reduction/Oxidation Metal Oxides for Thermochemical Energy Storage (PROMOTES)	Sandia National Laboratories
1554	Predictive Physico-Chemical Modeling of Intrinsic Degradation Mechanisms for Advanced Reflector Materials	National Renewable Energy Laboratory
1558	High-Temperature Falling Particle Receiver	Sandia National Laboratories
1586	Near-Blackbody, Enclosed Particle Receiver Integrated with Fluidized-Bed Heat Exchanger	National Renewable Energy Laboratory
1612	Low-Cost, Lightweight Solar Concentrators	Jet Propulsion Laboratory
1664	Integrated Solar Thermochemical Reaction System for the High Efficiency Production of Electricity	Pacific Northwest National Laboratory
1681	Nx-TEC: Next-Generation Thermionic Solar Energy Conversion	SLAC National Accelerator Laboratory
3588	Sulfur-Based Thermochemical Heat Storage for Based Load Concentrated Solar Power Generation	General Atomics
3596	Advanced Nitrate Salt Central Receiver Power Plant	Abengoa Solar
4008	Computational Analysis of Nanoparticles-Molten Salt Thermal Energy Storage for Concentrated Solar Power Systems	University of Texas at El Paso
5792	Flexible Assembly Solar Technology	BrightSource
5794	Self-Cleaning CSP Collectors	Boston University
5796	Advanced Manufacture of Reflectors	University of Arizona
5798	Scattering Solar Thermal Concentrators	Pennsylvania State University

**Table 4: Projects Reviewed under Concentrating Solar Power Program**

Award Number	Project Name	Project Organization
5799	High-Efficiency Receivers for Supercritical Carbon Dioxide Cycles	Brayton Energy
5800	A Small Particle Solar Receiver for High-Temperature Brayton Power Cycles	San Diego State University
5801	High Flux Microchannel Receiver Development with Adaptive Flow Control	Oregon State University
5802	Low-Cost, High-Performance Nanostructured Spectrally Selective Coating	University of California
5804	Development of a High-Efficiency Hot Gas Turbo-Expander and Low-Cost Heat Exchangers for Optimized CSP Supercritical CO <sub>2</sub> Operation	Southwest Research Institute
5805	Optimizing the CSP Tower Air Brayton Cycle System to Meet the SunShot Objectives	Southwest Research Institute
5806	Concentrated Solar Thermoelectric Power	Massachusetts Institute of Technology
5941	High-Operating-Temperature Heat Transfer Fluids for Solar Thermal Power Generation	University of California
5942	Halide and Oxy-Halide Eutectic Systems for High-Performance, High-Temperature Heat Transfer Fluids	University of Arizona
5954	Using Solid Particles as Heat Transfer Fluid for Use in CSP Plants	University of Colorado
6345	Physics-Based Reliability Models for Supercritical-CO <sub>2</sub> Turbomachinery Components	GE Global Research
6357	Improved Large Aperture Collector Manufacturing	Abengoa
6534	Carbon Dioxide Shuttling Thermochemical Storage Using Strontium Carbonate	University of Florida
6535	Regenerative Carbonate- and Silicate-Based Thermochemical Energy Storage System for CSP	Southern Research Institute
6536	Thermochemical Storage with Anhydrous Ammonia: Optimizing the Synthesis Reactor for Direct Production of Supercritical Steam	University of California, Los Angeles
6537	High-Temperature Thermochemical Storage with Redox-Stable Perovskites for CSP	Colorado School of Mines
25682	High-Efficiency Thermal Energy Storage System for CSP	Argonne National Laboratory
25683	Fundamental Corrosion Studies in High-Temperature Molten Salt Systems for Next-Generation Concentrated Solar Power Systems	Savannah River National Laboratory
25745	Low-Cost, Self-Cleaning Reflector Coatings for CSP Collectors	Oak Ridge National Laboratory
25828	High-Temperature Thermal Array for Next-Generation Solar Thermal Power Production	Los Alamos National Laboratory
25829	Degradation Mechanisms and Development of Protective Coatings for TES and HTF Containment Materials	National Renewable Energy Laboratory
25830	Low-Cost Heliostat for Modular Systems	National Renewable Energy Laboratory
25831	SAM Enhancements for CSP	National Renewable Energy Laboratory
25832	Direct S-CO <sub>2</sub> Receiver Development	National Renewable Energy Laboratory
25834	Dish Stirling High-Performance Thermal Storage	Sandia National Laboratories
25835	Low-Cost Metal Hydride Thermal Energy Storage System for CSP Systems	Savannah River National Laboratory
25837	The DOE National Solar Thermal Test Facility	Sandia National Laboratories
25838	High-Temperature Solar Selective Coating Development for Power Tower Receivers	Sandia National Laboratories

## PROJECT: 772 SACRAMENTO MUNICIPAL UTILITY DISTRICT

### SMUD CSP HIBRED Project

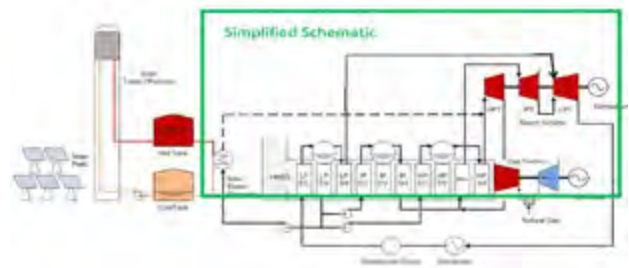

**FUNDING INFORMATION** \$10.0M | Heat Integration for Baseload Renewable Energy Development | 10/2012–12/2014

### Project Description

The Sacramento Municipal Utility District (SMUD) will design, develop, and demonstrate through commercial operation an advanced hybrid concentrating solar power (CSP) technology that will be integrated at an existing natural gas-fueled combined cycle power plant at SMUD. The CSP system will provide 45 megawatts thermal (MWt) peak solar collection and 32 MWt extended on-peak delivery to the power plant using stored energy for a net minimum reliable capacity increase of greater than 10 megawatts electrical solar generating capacity. The thermal energy input temperature to the thermal-to-electric conversion system's working fluid will be at or above 500°C. The CSP system will include high temperature thermal energy storage that will optimize reliable hybrid plant production during the summer afternoon peak and super peak dispatch hours.

### Individual Reviewer Comments

- The HiBRED project aims to demonstrate the economic feasibility of combining solar energy with a conventional (existing) combined cycle gas turbine electricity generating plant by adding solar heat (stored energy) to a heat recovery steam generator. This is probably the most effective way to demonstrate feasibility of the hybrid approach to pave the way for adoption of CSP/solar energy in combination with existing energy infrastructure.

- The project is a valid demonstration of technical capability on a plant scale and may require additional funding. There is potentially a large expenditure versus the shared value to industry, but this is a very good integration project. More projects like this one are needed.
- The path forward is not well-defined. The project may also get jammed up on DOE versus regulatory and permitting timeline complications, but that is okay.

Though all aspects for an optimal hybrid system (gas turbine combined cycle with solar heat addition) seem to be addressed, environmental and technological issues of integrating with an existing power plant need to be addressed. It is assumed these challenges can be overcome.

## PROJECT: 1533 PACIFIC NORTHWEST NATIONAL LABORATORY

### *Engineering a Novel High-Temperature Metal Hydride Thermochemical Storage*



**FUNDING INFORMATION** \$3.5M | Efficiently Leveraging Equilibrium Mechanisms for Engineering New Thermochemical Storage | 05/2014–04/2017

### Project Description

The project team will develop a concept for high energy density thermochemical energy storage for concentrating solar power (CSP), which is projected to meet SunShot energy and exergy efficiency targets. The full system will be designed, fabricated, and evaluated to culminate in on-sun testing with a solar dish to validate the projected efficiencies and full-scale performance. The technical concept is based on a system that consists of a high-temperature metal hydride bed for heat storage operating at greater than or equal to 650°C and 2.4 bar pressure connected to a second metal hydride bed operating at low temperature, which is used to store hydrogen near ambient temperature.

### Individual Reviewer Comments

- The overall plan is logical and has a high probability of meeting its objectives. The project uses hydrides, which have higher energy density, an appropriate temperature range, and high exergetic efficiency.
- This is a novel concept for a metal hydride thermochemical energy storage system for CSP. It is a near-term development (design, fabrication, and evaluation) project intended to meet the SunShot energy efficiency targets for 2020. Both the engine and the storage system will be tested with a solar dish to validate the projected efficiencies. The research and testing plan appears to be reasonable. In addition, the bench test demonstration was a plus; though, it was unclear whether the bench test is a cycle demo involving both low- and high-temperature reactors.
- Design of the high-temperature metal hydride reactor vessel will be important in maximizing heat transfer to the metal hydride bed. However, scale-up of the high-temperature metal hydride bed may require expertise from another discipline, such as chemical engineering.
- The process schematic shows liquid sodium as heat transfer fluid. This may have to be replaced by another heat transfer fluid, or it can be leveraged from another project.
- Because the project approach used hydrides, a need to take care of the hydrogen loop arises. In addition, a loop for a separate heat transfer fluid is used, transferring in and out of the metal hydride reactors. This mode increases the number of fluid loops, which increases the complexity of the system. For each one of the loops, components need to be designed and maintained (e.g., material interactions, corrosion, or reactivity).

## PROJECT: 1541 SANDIA NATIONAL LABORATORIES

### *High-Performance Reduction/ Oxidation Metal Oxides for Thermochemical Energy Storage (PROMOTES)*



**FUNDING INFORMATION** \$3.0M | Efficiently Leveraging Equilibrium Mechanisms for Engineering New Thermochemical Storage | 05/2014–04/2017

### Project Description

Sandia will systematically design, develop, characterize, and demonstrate a robust and innovative storage cycle based on novel metal oxides with mixed ionic-electronic conductivity (MIEC). Thermal energy is stored as chemical potential in these materials through a reversible reduction-oxidation reaction; thermal energy from concentrated sunlight drives a highly endothermic reduction reaction that liberates lattice oxygen from the oxide to form O<sub>2</sub> gas, leaving an energy-rich, oxygen-depleted solid. When desired, the heat is recovered as the MIEC is re-oxidized in an exothermic reaction upon exposure to air. The system is highly integrated with an air Brayton power cycle. The compressor of the Brayton engine delivers the heated, compressed air to the re-oxidizer reactor, which then drives the turbine of the Brayton engine; expansion of the air turns the turbine and generator, thus efficiently producing electric power.

### Individual Reviewer Comments

- This proposal leverages the experience and knowledge of novel metal oxides with MIEC at Sandia National Laboratories. Metal oxides show promise as air can be used as the working fluid, eliminating the need for other fluids (such as carbon dioxide) released from the chemical reaction. The innovative design of the reactor is noted.
- There is significant experience at Sandia on solar particle receiver design and operation. Direct solar irradiation leads to more efficient energy transfer to the particles.
- The research team will study an innovative and technologically challenging thermochemical energy storage (TCES) system. This includes the falling particle receiver.
- The overall system considered by the team (including collaborating partners) is highly innovative; however, at the same time, the project appears to be extremely risky. Owing to the large number of technological challenges that need to be overcome, the TCES is not likely to advance the SunShot CSP goals by 2020.
- It is unclear if the team is familiar with the work done by Japanese researchers (in the 1960–1980 time frame) on attempting to design and develop the high-temperature gas-particle nuclear reactor. Those researchers encountered a number of practical technological difficulties associated with the concept, and they eventually had to give up on developing the reactor. This past work by the Japanese may be relevant to the team, and they should become familiar with it.
- Repeated thermal cycling of particles may lead to particle attrition and creation of fines. Fine particles may have to be continuously removed from the system to avoid build up. Repeated cycling may also lead to material degradation.
- The re-oxidation reactor, as shown in the schematic, is likely to encounter operational problems. Common problems, such as repeatability of chemical reactions over numerous cycles and reaction speed, need to be studied further.

- For systems that use thermochemical means of endothermic absorption and exothermic release, these are still significant issues/challenges. If the  $O_2$  generated in the “evaporator” portion (reduction reaction) is not

stored, then more airflow is needed in the regeneration cycle (generate heat) during the “recombining” reaction. It is unclear why  $O_2$  is stored and reused, but appears to be released into the atmosphere. It is also unclear what the “cost” of not utilizing  $O_2$  studied would be.

## PROJECT: 1554 NATIONAL RENEWABLE ENERGY LABORATORY

### *Predictive Physico-Chemical Modeling of Intrinsic Degradation Mechanisms for Advanced Reflector Materials*

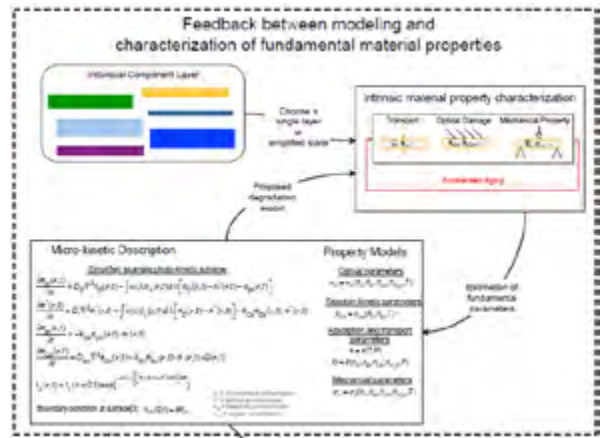

**FUNDING INFORMATION** \$2.1M | Physics of Reliability: Evaluating Design Innovations for Component Technologies in Solar | 01/2014–12/2016

### Project Description

The National Renewable Energy Laboratory (NREL) seeks to develop the capability to predict measurable characteristics from models of fundamental physico-chemical processes driving intrinsic degradation and failure mechanisms of advanced materials and coatings targeted for use in concentrating solar power (CSP) systems. The team will use novel physics- and chemistry-based modeling techniques to predict the time evolution of reflector properties under both controlled and real-world conditions. This prediction will be possible through the creation and application of validated, predictive models that use the measured behavior of individual materials to provide predictions for lifetimes of complete multilayer reflectors.

### Individual Reviewer Comments

- Degradation mechanisms are important in CSP plant lifetime predictions. An attempt to model these is proposed.
- Strengths of this project include addressing the important feature of the 30-year lifetime via predictive tools and the use of modeling that relates to fundamentals, such as Fick's Law and Maxwell's equations.
- The impact of this project may be significant, given the need to predict lifetimes. The basis of the modeling seems sound. Relevance is directly related to the prediction of 30-year lifetimes. Optical error, wind loading, and cost are not specifically highlighted. Funding is adequate.

- The project appears to be utilizing best practices for the modeling work, and it seems to be incorporating experimental results as well. There are many uncertain boundary conditions and processes in play. It will be a challenge for the model to beat accelerated aging tests in reliability estimation for real systems.
- The modeling looks very strong in the theoretical materials science area, but the practical aging (heat, UV, mechanical stresses, and cleaning abrasion) might be significant factors, and the models need to be heavily compared empirically.
- This is an interesting project, but it might be a lower direct SunShot impact as the approach/topic evolves.
- The project approach is good. However, the impact cost-wise seems to be loosely defined in terms of how this particular modeling tool might affect the SunShot Pareto chart for costs. In addition, it is unclear that this approach has been contemplated adequately to be adopted, but might shed light on the science behind the problem.

## PROJECT: 1558 SANDIA NATIONAL LABORATORIES

### *High-Temperature Falling Particle Receiver*

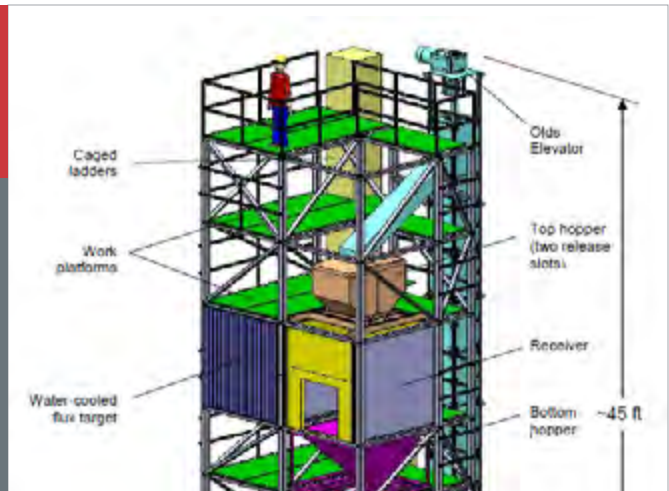

**FUNDING INFORMATION** \$4.5M | SunShot Concentrated Solar Power Research and Development | 10/2012–09/2015

### Project Description

The objective of this project is to make revolutionary advancements in falling particle receivers for concentrating solar power applications that will enable higher temperatures and greater efficiencies at lower cost. Technical innovations will be pursued through a combination of modeling, systems analysis, design, testing, and optimization. These include: (1) advances in receiver design with consideration of particle recirculation, air recirculation, and interconnected porous structures; (2) advances in particle materials to increase solar absorptivity, energy storage, and durability; and (3) advances in other areas, such as thermal storage, heat exchange, and particle conveyance.

### Individual Reviewer Comments

- This project has an innovative method to increase the operating temperature of solar plants and lower energy storage costs. The method has the potential to raise the temperature of heat transfer fluids to 1,000°C. Good progress has been made thus far. This is a potential complementary technology that must be evaluated.
- Strengths of this project include a plan that addresses all four goals of the receivers and heat transfer fluids area; a sound approach that incorporates design, particles, and balance of plant; and the build of a prototype demonstration system. The use of particle stock that is already round is noted. A best approach appears to be utilized, first studying tower design, then particles for use, and finally balance of plant. The design and build of a demonstration tower is a significant step toward demonstrating the technology.

- The effort appears attractive for all 4 technical targets, amply exceeding 650°C and on track for efficiency above 90%. Given the use of solid materials and an Olds elevator, a lifetime of 30 years may be very reasonable, and cost should be attractive.
- Project funding is adequate. An increase to study particle durability/longevity might be in order. The impact toward CSP goals is in high-temperature particle storage, heat exchange, and particle conveying. The durability of the optical properties of the particles over time is a concern, as erosion may cause particle fragmentation and rounding.
- Relevant area and wide-ranging approach across this subsystem. The cost impact of the development on receiver and storage elements is needed, as well as the integration aspect, so the impact is scored lower. The technical direction on materials and heat capacity is good, but again, it is hard to translate this into the cost and life aspects of related system impact.
- Management and transport of particles within systems seems rather awkward.



## PROJECT: 1586 NATIONAL RENEWABLE ENERGY LABORATORY

### *Near-Blackbody, Enclosed Particle Receiver Integrated with Fluidized-Bed Heat Exchanger*

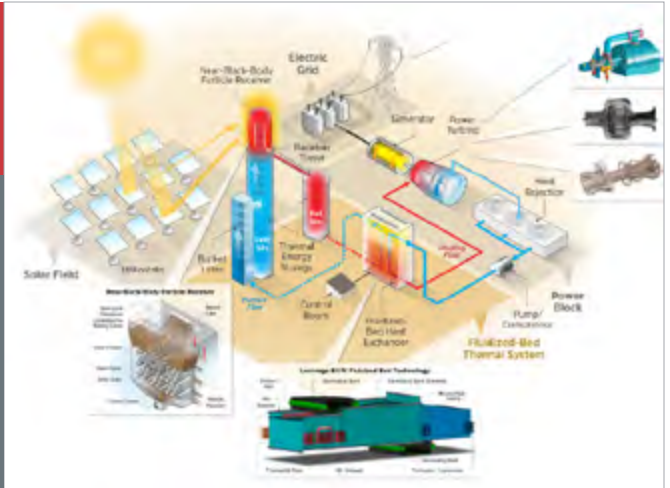

**FUNDING INFORMATION** \$3.7M | SunShot Concentrated Solar Power Research and Development | 10/2012–08/2015

### Project Description

The National Renewable Energy Laboratory (NREL) will design, develop, and test a prototype high-temperature particle receiver and heat exchanger system. Many existing receiver designs are limited by an upper operating temperature of 650°C due to the use of nitrate salt as the heat transfer fluid and the limitation of available high-temperature coatings for high-receiver efficiency. To overcome these limitations, NREL will develop an innovative receiver design with near-blackbody absorptive performance and select materials that can withstand temperatures of greater than 1,000°C. The concept uses low-cost stable materials, a ceramic solar receiver, and storage containers with refractory liners. These liners can accommodate temperatures much higher than oil/salt and ordinary metals or metal alloys at a fraction of the cost, thereby resulting in a low-cost, high-performance concentrating solar power system with thermal energy storage capability for baseload solar power.

### Individual Reviewer Comments

- An interesting alternative technology is being developed/tested as part of this project.
- Strengths of this project include a sound approach based on modeling, characterization, and prototype development. A pathway to cost and lifetime targets is noteworthy.
- This is a very good system impact and approach, considering all first-order aspects. Relevance includes high operating temperatures, adequate thermal efficiency, and a receiver that aims at a 30-year service life. The cost objectives are attractive and funding is appropriate.

- Best approaches include utilizing ray-tracing, FLUENT modeling, and building of a particle-flow/heat transfer test setup to characterize the process. The prototype will be verified in on-sun testing for validating design methodology.
- The project might be thin on the cost awareness of the particle handling, thermochemical energy storage, and related equipment. Additional development detail on the blackbody receiver is needed to better evaluate the project.
- Silica sand is used as absorbing particles, called “adequate.” It is unclear if there are more effective particle systems in view or under study.

## PROJECT: 1612 JET PROPULSION LABORATORY

*Low-Cost, Lightweight Solar Concentrators*

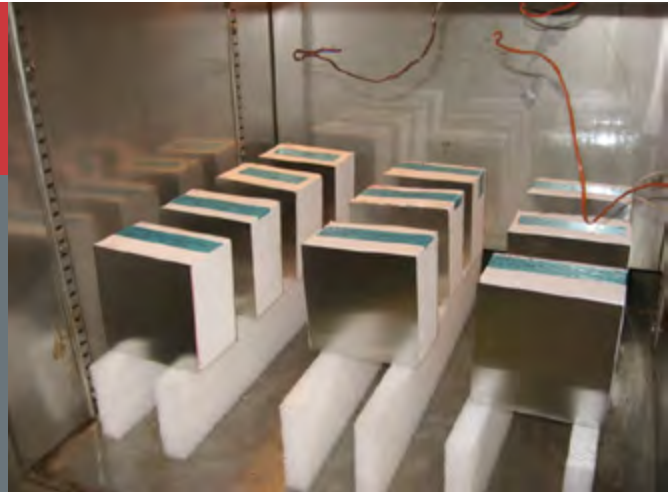

**FUNDING INFORMATION** \$2.3M | SunShot Concentrated Solar Power Research and Development | 10/2012–09/2015

### Project Description

The Jet Propulsion Laboratory is designing an optimized solar thermal collector structure using a lightweight collector capable of lowering structural costs and simplifying installation to reach mass manufacture. The specific project objectives are to design and develop a mirror module using an inexpensive reflective film bonded onto a lightweight structural rigid foam support; design and develop a low-cost, non-traditional mirror-module support structure; select low-cost drive components and associated control system; design, integrate, and test a low-cost concentrator; and analyze the system's cost to demonstrate achievement of the \$75/square meter (m<sup>2</sup>) collector system target.

### Individual Reviewer Comments

- Strengths of this project include a comprehensive approach that includes all parts of the concentrator cost, an optical error budget that seems reasonable for an initial concentrator, use of a film applique that has optimal optical properties, and coupon testing that was a reasonable first start.
- Good progress has been made on prototypes that perform well. The lightweight aspect is important for many reasons, as explained. Best practices include costs being estimated utilizing vendor-based estimates, surface quality (static) is reasonable, mechanical structures successfully analyzed, and facet dimensions successfully optimized. The funding level seems appropriate for the project. Use of a phased approach implies additional funding will be required in the future.

- The team is taking an “all elements of the concentrator” approach to the design optimization, suggesting a successful approach to achieving the solar field technical targets. The project has had impact by demonstrating a lightweight, low-cost rigid foam sandwich structure equipped with a reflective film. Initial costs are estimated at \$95–\$115/m<sup>2</sup>. Optical error is reasonable (for the static case); lifetime is only suggested by coupon testing. The wind speed determination is partial, up to 27 miles per hour.
- This proposal lacks structure in terms of spend and expected results. Costs are the key in the collector subsystem, including materials, reflector frame assembly, and field impact over life. In addition, the poster would have benefited from connecting the coupon testing results to a years-long durability value in order to gather a metric on the 30-year lifetime.
- Some questions remain in terms of wind versus performance (pointing), along with manufacturing of the array to control canting and wind loads.
- The wind loading is a significant factor at the unit and system level that may be underrepresented here. Integration at the assembled level for durability is a concern. The canting aspect is not adequate and is a major player in the root mean square pointing error. Film-based reflectors are of interest, but need all these factors considered to be more valuable. The cost aspects need to include labor, equipment, and related install costs.
- The cost target is still not met and does not seem to be reachable with the methods applied. More effort is needed to achieve this.

## 1664 PACIFIC NORTHWEST NATIONAL LABORATORY

### *Integrated Solar Thermochemical Reaction System for the High Efficiency Production of Electricity*

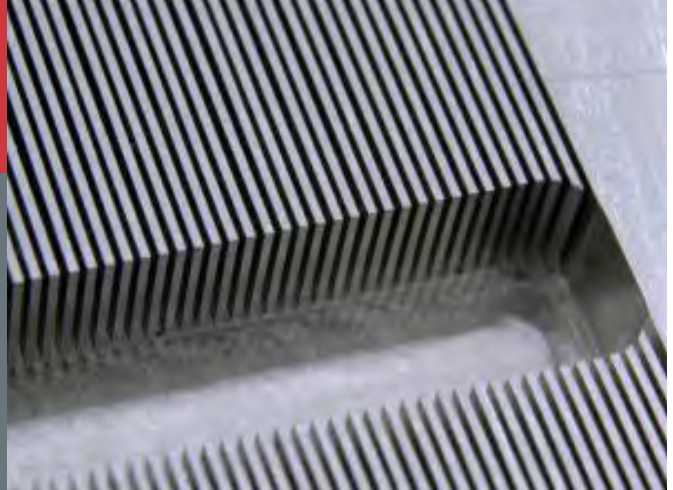

**FUNDING INFORMATION** \$3.5M | SunShot Concentrated Solar Power Research and Development | 10/2012–09/2015

### Project Description

Pacific Northwest National Laboratory (PNNL) seeks to advance the technology of solar thermochemical reaction systems from Technology Readiness Level (TRL) 3 to TRL 6. To accomplish this, PNNL will improve the performance of the system and establish the design and manufacturing methods that enable solar power generation at a levelized cost of energy of no more than \$0.06/kilowatt hour by 2020. Specific project goals include improving the performance of the solar thermochemical reaction system, improving the solar-to-chemical energy conversion efficiency from 63% to about 75%, increasing the solar thermochemical augment from about 20% to as much as 28%, reducing the manufacturing costs, and establishing a validated baseline for capital costs of solar thermochemical systems.

### Individual Reviewer Comments

- This is an innovative project. It builds on previous work and is probably one of the few PNNL projects that may have some impact on achieving the SunShot concentrating solar power (CSP) electric power generation goals for 2020. This is one of the best projects in the entire SunShot CSP portfolio! Research and demonstration of integrated systems, integrating “solar boost” to a convention power system such as a gas turbine system are important to incremental adoption of solar energy. Incorporation of micro- and meso-channel heat exchangers will also be very helpful.
- The use of micro- and meso-channel process technology is a novel feature and makes scale-up relatively easy. Micro- and meso-channel reactors will enhance heat and mass transfer.
- The catalyst is not expected to deactivate. This avoids all problems associated with catalyst regeneration and/or loading and unloading of a catalyst.
- The project is not without some risks. The micro- and meso-chemical process technology represents a novel feature, but the scale-up—while challenging—may be manageable. The path forward needs some clarification.
- It is unclear if methane reforming requires water, as the equation shows  $H_2O$ . As in solar environments, water is a pricey commodity.
- Though micro- and meso-channel hydrogen halides were mentioned, no progress report was presented. Details of the on-sun tests showing 69% solar-to-chemical conversion efficiency need to provide more details. The system needs to address the common issue faced by chemical energy systems: reversible chemical reaction systems (fast reactions, repeatability of chemical reactions over numerous cycles).

## PROJECT: 1681 SLAC NATIONAL ACCELERATOR LABORATORY

### *Nx-TEC: Next-Generation Thermionic Solar Energy Conversion*



**FUNDING INFORMATION** \$0.8M | SunShot Concentrated Solar Power Research and Development | 10/2012–12/2014

### Project Description

This research will create a new solid-state energy conversion technology based on microfabricated and photon-enhanced thermionic energy converters (PTECs), which—when used as a topping cycle in concentrating solar power (CSP) systems—will enable system efficiencies in excess of 50%. Using device and system modeling, the team will design thermally isolated, thermionic arrays and microelectromechanical-based wafer-stack technologies for their fabrication, culminating in the demonstration of devices with greater than 5% power conversion efficiency. In parallel, the team will fabricate heterostructure semiconductor cathodes based on active layer absorbers, such as GaAs and similar materials, with the addition of band engineered passivating layers, such as GaN, to demonstrate high quantum efficiency Photon-Enhanced Thermionic Emitters (PETE). The resulting Nx-TEC device will achieve a stand-alone laboratory efficiency of more than 15%; a significant intermediate step toward a stand-alone goal of more than 30%, which is needed to achieve the more than 50% system efficiency target.

### Individual Reviewer Comments

- The project has put forth a new idea to enhance thermionic emission by photons and top with a CSP plant via residual leftover heat. The project is well-published, and reasonable progress has been made. Best approaches appear to be utilized, including use of GaInP and similar materials. Overall, this is an interesting alternative deserving research for sure.

- PETE is difficult to evaluate against the technology targets, but the comprehensive explanation of the PETE devices is a strength.
- The idea of harvesting electrons and utilizing the waste heat in a bottoming cycle is fair. Funding is also fair.
- There are many integration issues to apply to solar thermal to assess the system cost impact. That said, the project has merit and is great fundamental research.
- The team has taken a key research-level approach. However, there is no indication of cost feasibility or project outlined at this point. It will probably go to non-CSP markets first. It might be early to think about scale-up cost, but the team could at least make a model of what can be allowed in cost increase versus value of efficiency. Project impact and relevance are unclear.
- The heterostructure architecture required to improve conversion efficiency may not be practical in the field. It is not addressed in the report.

## PROJECT: 3588 GENERAL ATOMICS

### *Sulfur-Based Thermochemical Heat Storage for Based Load Concentrated Solar Power Generation*



**FUNDING INFORMATION** \$2.0M | Baseload | 09/2010–11/2014

### Project Description

The goal of the project is to demonstrate the engineering feasibility of using a sulfur-based thermochemical cycle (TC) to store heat from a concentrating solar power (CSP) plant and support baseload power generation. The team will study the sulfur-generating disproportionation reaction and develop it into a practical engineering process step. The team will also carry out preliminary process components design and experimental validation. The engineering data will be used for process integration between the CSP plant, the sulfur processing and storage plant, and the electricity generation unit. Through this project, the team will demonstrate the economics and safety of a CSP plant integrated with sulfur storage.

### Individual Reviewer Comments

- The goal of this project is to demonstrate the engineering feasibility of using sulfur-based TC to store heat from a CSP plant and to support baseload power generation. The TC based on sulfur does not produce any waste effluent and does not emit any greenhouse gases.
- According to the project summary, no technical barriers remain, and the next step is to design, build, and then test a 300-kilowatt (kW) demonstration testing system. In addition, the technology seems to be at a higher readiness level. It is encouraging to note a 300-kW system demo in progress with a subsystem tested Onsun.
- Though it is unclear from the documentation provided what part of the work is being done by which partner, it appears that the team has made satisfactory progress during the last three years in meeting the overall project objectives.
- The sulfur acid decomposition and sulfur dioxide disproportionation reactions appear to be well in hand, and the sulfur combustion study is ongoing. The project has a sound experimental plan to study the disproportionation reaction. In addition, sulfuric acid manufacturing has been around for many decades and there is wealth of information in the literature. Topics such as handling, storage, and environmental issues have been solved and could be leveraged in this study.
- Reported research on using a heterogeneous catalyst for disproportionation, if available, would greatly simplify the reactor design and avoid the problems with separating and recycling homogeneous catalyst.
- The TC uses very corrosive chemicals, and hence, selection of appropriate material of construction for the disproportionation reactors on commercial scale will be critical.
- The material of construction will negatively impact the economics. In addition, the process to recover dissolved iodine catalyst is complex, and low recovery will negatively affect economics. Plus, dissolved iodine will make the system more corrosive.
  - The proposed system involves a three-step process with catalyst involved, making it a fairly complex system. There are significant issues around storing sulfur and sulfuric acid. Sulfur, as the working fluid, is not very attractive with many attendant issues, including: identification of which byproducts are created in a sulfur combustor, how the byproducts relate to emission regulations, and the potential fluid handling issues for these corrosive chemicals (valves, pumps, seals, etc.).
- The system involves generally environmentally unfriendly and corrosive materials. The proposed system for baseload application seems to be a stretch.

**PROJECT: 3596**  
**ABENGOA SOLAR**

*Advanced Nitrate Salt Central Receiver Power Plant*



**FUNDING INFORMATION** \$4.5M | Concentrated Solar Power Baseload | 09/2010–06/2014

### Project Description

Abengoa will demonstrate a 100-megawatt central receiver plant using nitrate salt as the receiver coolant, thermal storage medium, and heat transport fluid in the steam generator. The plan is to operate the plant at full load for 6,400 hours each year using only solar energy. Key components include a new high-temperature molten salt receiver based on a fossil boiler and heat exchanger design that will be more robust and more manufacturable; a cermet, high-temperature, low-emissivity selective coating for central receivers that is stable when exposed to air; an optimized surround heliostat field; and an optimized thermal storage, steam generator, and power cycle configuration based on dry cooling.

- Funding levels were mixed by reviewers, as one reported it as “fair” and another noted that the specific efforts outlined seem incremental in nature as opposed to the outlined cost, which resulted in a lower funding score.
- The key weakness is that this project focuses on improvements on existing technology rather than new concepts.

### Individual Reviewer Comments

- The project has a clever use of the yield curve after a short number of thermal cycles. The effort offers the weakness of utilizing temperature-limiting molten salt. Good test work on salt breakdown temperatures. The project has made much progress in meeting the goals of the original proposal.
- The project’s relevance, impact, and best approaches are fair. The project is relevant because it is not exceeding the technical target of 650°C; although, suggesting longevity of operations even though there are insufficient data available to really assess the impact projected on cost. Impact is fair given thorough studies completed on optimum baseload operations having a thermal storage capacity of six hours as ideal. The best approaches also appear fair, including a detailed cost analysis and plant design.

## PROJECT: 4008 UNIVERSITY OF TEXAS AT EL PASO

### *Computational Analysis of Nanoparticles-Molten Salt Thermal Energy Storage for Concentrated Solar Power Systems*

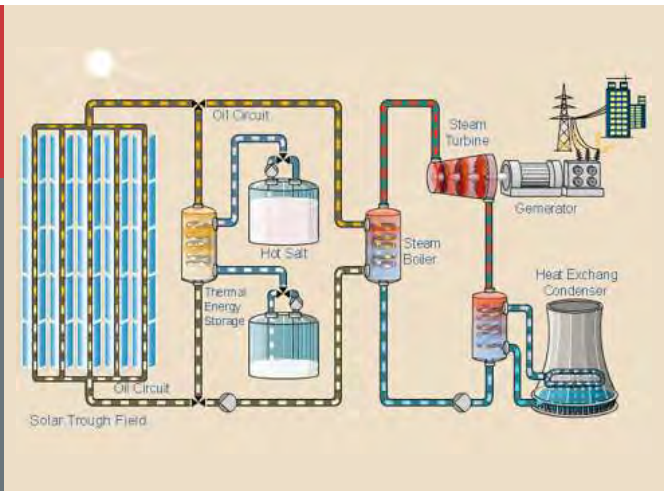

**FUNDING INFORMATION** \$0.27M | Minority University Research Associates | 09/2010–09/2014

### Project Description

The research goal of this project is to perform computational analysis for designing an efficient and cost-effective thermal energy storage (TES) system for CSP using nano-fluidized molten salt as the storage medium. An efficient TES system contributes to reaching the SunShot goal of making solar electricity cost competitive with conventional sources. The educational efforts include an interdisciplinary course designed specifically for students with different backgrounds who share a common interest in renewable energy, a targeted solar energy workshop at the University of Texas at El Paso, and student and faculty visits and summer research at the National Renewable Energy Laboratory and Sandia National Laboratories.

### Individual Reviewer Comments

- Development of human capital to partake in the future is important to the workforce in solar energy. It is inexpensive given that there are many trainees. The development of human capital and efforts in science, technology, engineering, and math (i.e., STEM) education are the major strengths of the project.
- The funding requested is relatively modest, and the proposed visits to the National Renewable Energy Laboratory and Sandia National Laboratories should provide the principal investigator and the student an opportunity to interact with the researchers at those laboratories.
- The presence of nanoparticles in molten salts does not appear to provide sufficiently significant advantage in thermophysical properties to justify their serious consideration in single tank TES. The project is not sufficiently innovative, and the computational modeling effort is relatively routine.
- The weakness of the effort is in investing in molten salts with limited upper temperature capability. There have been minimal improvements achieved by doping the molten salt with nanoparticles at approximately 5%.
- Even if the proposed project is satisfactorily completed, the potential payoff is not expected to advance the SunShot CSP technology goals.

**PROJECT: 5792  
BRIGHTSOURCE**

*Flexible Assembly  
Solar Technology*

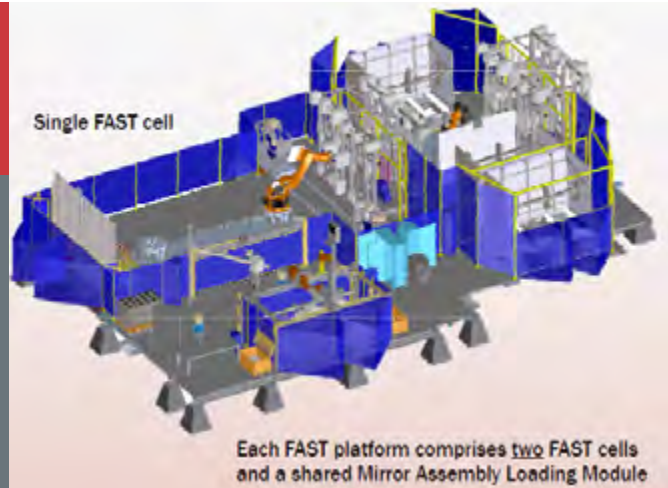

**FUNDING INFORMATION** \$4.8M | SunShot Concentrated Solar Power Research and Development | 08/2012–04/2014

**Project Description**

BrightSource Energy is designing and deploying an automated collector assembly platform and a more efficient installation process that has the potential to drastically reduce construction time and cost for utility-scale concentrating solar power facilities. This Flexible Assembly Solar Technology (FAST) system accelerates the heliostat assembly and field installation processes by combining elements of both on a single platform with direct access to the solar collector field. The system incorporates preliminary, partial assembly of the mirror units at a centralized offsite facility capable of supplying multiple CSP projects; an automated, transportable FAST platform for assembly completion; and delivery of the fully completed assemblies into the solar field for final installation.

**Individual Reviewer Comments**

- The project offers a common-sense approach to solar plant construction at a centralized facility. The impact is in the merit of having a centralized facility capable of supplying multiple CSP projects, onsite assembly, and service to multiple installation locations. The transportation cost is a plus.
- Relevance is in the area of achieving one technical target for the solar field: cost. The mobile platform can achieve assembly to design specifications.
- One of the project’s strengths is the 50% reduction in labor costs, which indicates that the approach is fair.

Multiple heliostat sizes are a plus. The heliostat assembly cost problem is a real challenge for industry. That said, with this fairly large project funding, additional details beyond 50% reduction of cost should be outlined.

- The project is derived from operational lessons learned in the logistics and assembly deployment as opposed to the research and development category. It is a good direction of cost reduction, but seems like incremental change in nature.
- A weakness is a poor discussion of all costs now and all costs with the 50% reduction in labor in order to indicate that the \$75/square meter goal could be achieved.
- This is an expensive project, and the level of innovation is rather low. Minimal detail was provided on what the project accomplished and, as a whole, this was a somewhat sketchy, repetitive report with a missing section.



## PROJECT: 5794 BOSTON UNIVERSITY

### *Self-Cleaning CSP Collectors*



**FUNDING INFORMATION** \$0.7M | SunShot Concentrated Solar Power Research and Development | 08/2012–01/2015

### Project Description

Boston University is developing a new method to keep solar collectors dirt- and dust-free to help maintain high optical efficiency. This project aims to develop large-scale prototypes and cost-effective manufacturing processes, and to commercialize the technology in large-scale concentrating solar power (CSP) devices for applications in semi-arid and desert climates. Specific objectives include establishing proof-of-concept of the application of the electrodynamic screen (EDS) for self-cleaning solar concentrators; producing and evaluating laboratory-scale prototypes of self-cleaning solar collectors, including flat mirrors and curved mirrors; and testing the EDS-incorporated collectors for optical efficiency of sunlight, dust removal efficiency, power requirements, and durability.

### Individual Reviewer Comments

- The project has an interesting concept: electrical grid driving contaminants off panels (three-phase voltage needed).
- Strengths of the project include robust testing and modeling efforts. Observed specular reflection efficiency greater than 90% is also a strength. Efforts to quantify cost savings (estimated to be 50% of the water budget) are noteworthy.
- Relevance is cost-specific, derived from a reduction in long-term maintenance savings. Optical error improvements and wind survivability are not addressed. Lifetime of operation information is implied. Funding is appropriate. The impact is in the area of new technology investment, utilizing a minimum amount of power per cleaning cycle, and maintaining greater than 90% reflection.
- The use of best approaches is indicated through investments in coupon testing, instrument development, and modeling. Development of a cleaning cost model is noted.
- The team should consider combining technology with the hydrophobic coating research by Hunter at Oak Ridge National Laboratory.
- The project does not have a logical approach to solving the net cost problem to a stated goal. This is an interesting technical challenge, but this project seems to be way out of balance in the goal of reducing capital expenditure and operational expenditure cost.
- The research and development aspect of this project seems like a big disconnect in terms of strong SunShot goal linkage. Substantial work needs to occur to comprehend how the SunShot goals would be impacted. During review, there was inadequate explanation of how this would be addressed.
- No cost estimates were given, but were listed as “under development.” No project funding data or duration was provided. Some competing concepts, such as self-cleaning coatings, are more likely to be cost effective in the long run.

**PROJECT: 5796**  
**UNIVERSITY OF ARIZONA**

*Advanced Manufacture of Reflectors*



**FUNDING INFORMATION** \$1.5M | SunShot Concentrated Solar Power Research and Development | 08/2012–04/2014

## Project Description

The University of Arizona is developing technology to improve the optical accuracy and reflectivity of the self-supporting glass mirrors used in concentrating solar power collectors. The research team is working to optimize and validate a novel glass-molding technique that creates very precise mirrors in a variety of shapes. The focus is on developing a novel hot glass molding process that could be used for high-speed production at low cost and be easily integrated into a production line. In parallel, the research team is developing a novel way to boost second-surface silver reflectivity and inhibit soiling. The goals of the project are to develop new methods for rapidly shaping glass mirrors and coating them for higher reflectivity and soil resistance, include both point-focus and line-focus mirror designs, improve mirror optical accuracy, and reduce the cost of the solar trough mirrors made in very high volume by about 40%.

## Individual Reviewer Comments

- Strengths of the project include the use of a rapid hot-shaping cycle and the use of metrology to determine accuracy. Collaboration with a business entity is noted. This project also has an experienced team consisting of university and industry partners. Professor Angel is a true pioneer in the field.

- Novel method gravity slumping deserves research and verification. The team has also demonstrated accuracy of fabrication with laser methods.
- Relevance to program goals includes a promising optical error budget leading toward the technical target of 3 milliradians. Cost analyses suggest \$20/m<sup>2</sup> (though a wind speed analysis is missing). The lifetime is potentially attractive. The project also appears to be utilizing best approaches, including a make and test approach and demonstrated repeatability.
- Glass shaped by gravity slump method is conducive to manufacturing on a large scale. The glass offers a drawback in that hoped-for improvements to reach 95% reflectivity were not successful due to the oxidation state of iron in the glass.
- While interesting, the effort is not setting goals as a system at a sufficiently aggressive level. The \$20/square meter goal is not low enough given that this development does not appear to remove enough cost from other component or system-level areas. Examples include structures, attachment, and in-field temperature effects. Significant cost is expended without taking this larger view into consideration; I would suggest that these be considered as part of this subsystem. Otherwise, this is a very interesting research and development and process activity.

**PROJECT: 5798 PENNSYLVANIA STATE UNIVERSITY**

*Scattering Solar Thermal Concentrators*

Impact of cosine projection loss:

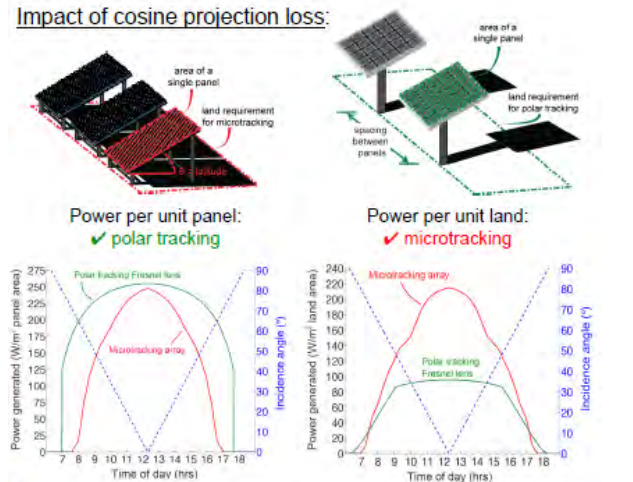

**FUNDING INFORMATION** \$0.2M | SunShot Concentrated Solar Power Research and Development | 08/2012–10/2014

**Project Description**

Penn State is designing and testing a novel solar collector system that relies on stationary optics and avoids the need for mirror movement. The system is capable of achieving optical performance equal to state-of-the-art parabolic trough systems, but at a lower cost. The research team is working to demonstrate a scattering solar concentrator with optical performance equal to existing designs of state-of-the-art parabolic troughs, but with the added benefits of immunity to wind load tracking error, more efficient land use, and elimination of movable heat transfer elements. The goals of the project are to demonstrate a small-scale, fully functioning prototype and test its performance outdoors, attain break-even optical performance compared against existing parabolic troughs, and improve the overall performance and reliability of the collector field.

- This is a good research and development effort to prove out concentrating solar power (CSP), but, as noted, concentrated photovoltaics (CPV) does appear to be more fertile.
- The project needs more structure on cost expectations and how the project expects to change the status quo on alternative CSP and CPV methods. The absolute cost, however, in terms of energy and size and component cost rough estimates are a big question on impact here.
- This project will not work for CSP, but it may be useful in photovoltaic microcell installations.

**Individual Reviewer Comments**

- This project has an interesting concept to solar panel motion: local scattering and waveguiding. Good progress has been made, land-use optimization is a plus, and the funding has been fair.
- The relevance to technical targets is obscure. The impact is also minor, but there may be merit for photovoltaic applications.

**PROJECT: 5799**  
**BRAYTON ENERGY**

*High-Efficiency Receivers for Supercritical Carbon Dioxide Cycles*

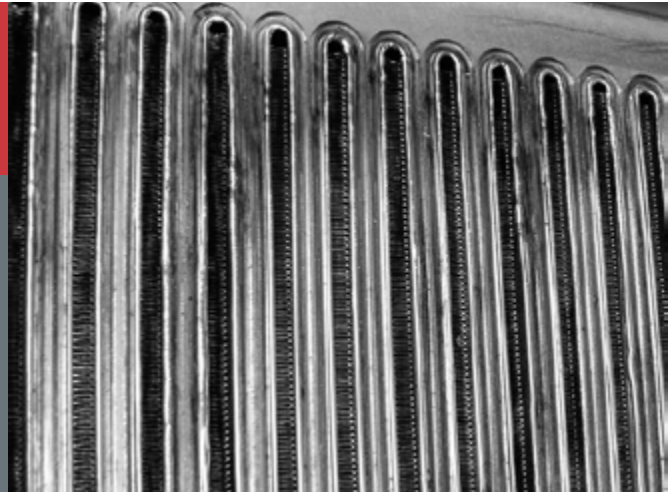

**FUNDING INFORMATION** \$1.6M | SunShot Concentrated Solar Power Research and Development | 09/2012–08/2015

**Project Description**

Brayton is building and testing a new solar receiver that uses supercritical carbon dioxide (s-CO<sub>2</sub>) as the heat transfer fluid. The research team is designing the receiver to withstand higher operating temperatures and pressures than state-of-the-art technology so that the device can enable higher-efficiency systems. The primary objectives of this project include achieving an outlet temperature for the receiver working fluid (s-CO<sub>2</sub>) that is greater than or equal to 750°C, maintaining high receiver efficiency, retaining durability over the lifetime of the concentrating solar power plant, and significantly reducing the cost as compared to baseline receivers. To satisfy these objectives, the team is performing a combination of analytical modeling and hardware testing. The use of s-CO<sub>2</sub> in the power cycle is also being explored.

**Individual Reviewer Comments**

- This is a well-argued and well-documented project. It looks like a very good potential solution, and it deserves a thorough study and the funding granted.
- Strengths of the project include being on track for achieving technical targets, a sound approach that includes a combination of component testing, and a cost estimate that seems reasonable.
- Project relevance is high, given that the effort will achieve all 4 technology targets, 750°C outlet temperature, greater than 92% thermal efficiency, creep life suggesting 10,000 cycles, and a reasonable cost estimate.

- The project impact is high, given the direction of utilizing s-CO<sub>2</sub> as a working fluid. A robust receiver capable of operating under ultrahigh pressure will be needed for this application.
- Best practices appear to be utilized, including low-cost materials, component testing, and on-sun testing. Additional testing includes burst, creep, fatigue, and thermo-hydraulic performance testing.
- Funding is reasonable for this project. There are also good relevance and impact areas, but it is hard to tell on spending breakdown and specific metrics to be tied into SunShot goal impact. That work is planned, but the framework should be started now on this.
- The power cycle subarea is not clear in the documents in terms of whether that work funded really includes a time scale. The team should see if there is applicability to other fluids.
- Multi-part finned structures may have increased failure rates in field use.

## PROJECT: 5800 SAN DIEGO STATE UNIVERSITY

### *A Small Particle Solar Receiver for High-Temperature Brayton Power Cycles*



**FUNDING INFORMATION** \$3.1M | SunShot Concentrated Solar Power Research and Development | 09/2012–08/2016

### Project Description

The objective of this project is to design, construct, and test a revolutionary high-temperature solar receiver in the multi-megawatt range that can be used to drive a gas turbine to generate low-cost electricity. A secondary goal is demonstrating, for the first time, a pressurized solar receiver with a window greater than 1 meter in diameter. The proposed use for the receiver is to drive a gas turbine, but such a receiver can also be used for process heat applications and solar processing of fuels and chemicals. The capability of the receiver to generate pressurized (0.5 megapascal) and high temperature (approximately 1,000°C) air at high efficiency (approximately 90%) will be demonstrated at the multi-megawatt level via prototype testing at the National Solar Thermal Test Facility at Sandia National Laboratories.

### Individual Reviewer Comments

- This is an innovative project that could prove practical. Good progress had been made so far. Strengths include an effort successfully addressing all four technical targets, a sound modeling suite, and successful particle generator operation enabling suitable demonstration of the technology. Funding is exceptional, as an exceptional value is being received for the investment.
- Many masters' theses have been produced, and more are ongoing from the team. The team has made a good contribution to development of human capital for the concentrating solar power field.
- Relevance is ideal, where efficiency is improved above 650°C operation and a combined gas-turbine and steam-generating system. The volumetric receiver offers the potential for a 10,000 cycle lifetime. Cost should be minimal based on simplicity of the design. Use of natural gas is noted. Impact is also high. The use of absorbing the solar flux in a volume as opposed to a wall has impact. Particles are oxidized leaving high-pressure gas to operate the gas turbine.
- Best approaches include a suitable suite of modeling, successful prototype particle generator operation, and receiver window design.
- The team has made good recognition of heavy loss on quartz window.
- The project is unclear in terms of the cost and cost per watt metrics in this phase. It looks like the effort might show a functioning system, but it would expect additional detail on efficiency, life, and these cost metrics to round out the effort. The team needs to come up with rough cost benchmarks at this point to compare to SunShot goals. More of this assessment is needed to sort out viability to the next phase.
- The project has mostly consisted of simulations at this point. The project needs to emphasize the experimental part in the second half. It is unclear what happens to the oxidized nanoparticles.
- Dependence on a source of natural gas is a weakness of the project

**PROJECT: 5801**  
**OREGON STATE UNIVERSITY**

*High Flux Microchannel Receiver Development with Adaptive Flow Control*

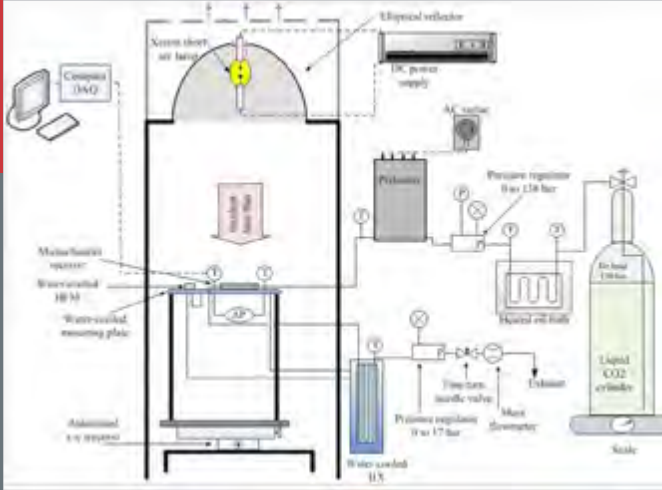

**FUNDING INFORMATION** \$0.8M | SunShot Concentrated Solar Power Research and Development | 08/2012–02/2015

### Project Description

Oregon State University (OSU) seeks to reduce the size, weight, and thermal losses from high-temperature solar receivers by applying microchannel heat transfer technology to solar receiver design. OSU’s objective is to design a supercritical carbon dioxide (CO<sub>2</sub>) microchannel receiver operating at a fluid exit temperature of 650°C and absorbing an average flux of 100 W/cm<sup>2</sup> with a receiver efficiency of 90% or greater. OSU plans to develop two microchannel solar receiver designs, one for liquid cooled microchannel receivers and one for gas cooling. Metrics were determined using one-dimensional heat transfer calculations to estimate the maximum flux that could be absorbed on a microchannel solar receiver as a function of channel characteristics. Metrics for the supercritical CO<sub>2</sub> receiver will be based on “on-sun” experimental results. Metrics for the other design will be based on laboratory test results, modeling, and simulation.

### Individual Reviewer Comments

- The project offers an innovative means to increase heat flux for key fluids. Strengths include a clear demonstration of the technical feasibility of the microchannel design, significant progress in machining and testing of microchannel concepts useful for both molten salt and supercritical CO<sub>2</sub>, and successful work toward a full scale 1 square meter (m<sup>2</sup>) panel suitable for use in a tower.

- Detailed, multilevel quantitative results were shown. The poster provided an excellent summary. The project’s impact is significant in that the optimal microchannel design was successfully manufactured and tested, yielding credible and appropriate heat flux results.
- Relevance is indicated via the basic physics of heat transfer, as optimized for microchannels, and the process of designing for both a molten salt and supercritical CO<sub>2</sub> conditions. Technical feasibility was demonstrated, and the needed flux values were obtained, along with heat transfer exit temperatures and thermal efficiencies.
- The approach is sound for designing, machining, and initial testing. The work toward a preliminary design based on 1 m<sup>2</sup> panels is noted. Funding also seems adequate.
- The expected scaled-up impact to the receiver net cost per thermal rating was not identified. The project might change cost versus thermal capacity of the receiver system, but it is hard to tell from the information provided.
- Although this is a seedling project, the cost-focus earlier in a project can be more effective in guiding otherwise heavy reinvention that will occur later.
- Complex modules may have high failure rates and should be addressed.

## PROJECT: 5802 UNIVERSITY OF CALIFORNIA

### *Low-Cost, High-Performance Nanostructured Spectrally Selective Coating*

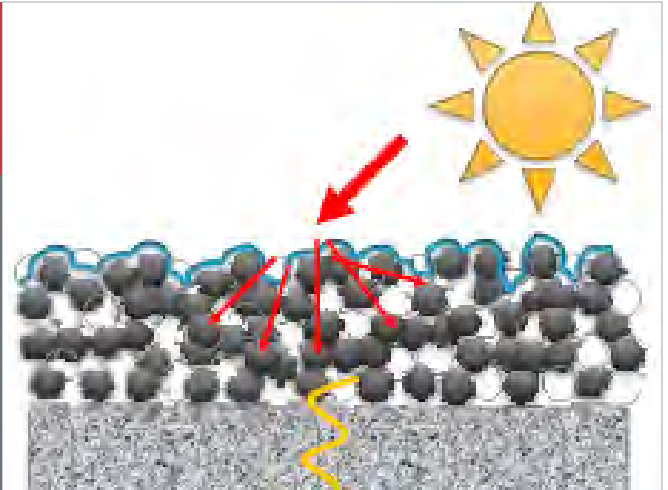

**FUNDING INFORMATION** \$0.9M | SunShot Concentrated Solar Power Research and Development | 08/2012–03/2015

### Project Description

The University of California, San Diego will employ a highly scalable process to fabricate and coat nanoparticles onto solar absorber surfaces to achieve ultrahigh spectral selectivity. Refractory protected and unprotected semiconductor nanoparticles will be fabricated by spark erosion and coated onto absorber metal surfaces by spray coating. The material composition, size distribution, and morphology of the nanoparticles will be guided by numeric modeling, as well as optimized by design of experiment tests. Optical and thermal properties, such as solar absorptance and infrared emittance, will be modeled and measured. High temperature durability will be achieved by using modified semiconductors, refractory nanoparticles, ceramic matrix nanocomposites, and high temperature annealing. The proposed spectrally selective coatings will achieve solar absorptance of greater than 94% and infrared emittance of lower than 7% at 750°C. This will enable higher thermal conversion efficiency (greater than 90%) and operating temperature of heat transfer fluids (greater than or equal to 650°C) in order to achieve lower operations and maintenance costs.

### Individual Reviewer Comments

- An important problem is being addressed by this project: high-temperature effective absorbers are essential in concentrating solar power. The project has a sound approach to making and depositing particles with a good prospect for scale-up, suggesting cost containment.
- Life and field reapplication considerations at end of life in the Figure of Merit structure were covered as part of the review. These aspects continue to be key for value analysis of coatings.
- The impact of the project is fair. The spraying feature, utilizing particles of a particular size, is the most important aspect to driving down costs. The thermal cycling feature is a modest start toward 10,000 cycles. Particle durability remains uncertain. Funding is also adequate.
- The project approach is sound. Manganese zinc ferrites and other types of black oxides were made into nanoparticles. Testing has shown that they have been found to possess excellent high-temperature stability at 750°C. The sunlight absorption figure of merit reaches the desired value of 90%. At least initial coupon testing suggests satisfactory mechanical durability of the coating on Inconel. Modeling for particle size is noted.
- The expected cost impact to SunShot key goals and how to compare to the current state is unclear. The project also does not address cost estimates, though a spray technique is conducive to low-cost operations.
- After 10 thermal cycles, the coating is beginning to fail under scotch-tape test. This does not bode well for practical deployment under long-term harsh conditions.

## PROJECT: 5804 SOUTHWEST RESEARCH INSTITUTE

*Development of a High-Efficiency, Hot Gas Turbo-Expander and Low-Cost Heat Exchangers for Optimized CSP Supercritical CO<sub>2</sub> Operation*



**FUNDING INFORMATION** \$6.8M | SunShot Concentrated Solar Power Research and Development | 09/2012–07/2015

### Project Description

The Southwest Research Institute aims to develop a novel, high-efficiency supercritical carbon dioxide (s-CO<sub>2</sub>) hot gas turbo-expander optimized for concentrating solar power (CSP) applications, which have highly transient duty cycles. A secondary objective is to optimize novel printed circuit heat exchangers for s-CO<sub>2</sub> applications to drastically reduce their manufacturing costs. The s-CO<sub>2</sub> turbo-expander and novel s-CO<sub>2</sub> heat exchanger will be tested in a 1-MWe s-CO<sub>2</sub> test loop and fabricated to demonstrate performance of the components and the optimized s-CO<sub>2</sub> Brayton cycle over a wide range of part load conditions and during representative transient operations. The scalable s-CO<sub>2</sub> expander design and improved heat exchanger address and close two critical technology gaps required for an optimized CSP s-CO<sub>2</sub> power plant.

### Individual Reviewer Comments

- Two fabrication methods were selected for heat exchangers and prototypes were pressure tested. Novel turbo machinery was designed. The team has a good plan for test loop design based on piping simulations.
- The turbo-expander is a critical part of the s-CO<sub>2</sub> system, so it is appropriate to develop relevant technology aimed at lower-cost, higher-efficiency turbine (similarly for lower-cost heat exchangers).
- This is a novel component development project intended for s-CO<sub>2</sub> hot gas turbo-expander, specifically

intended for CSP applications. In parallel, low-cost heat exchangers for s-CO<sub>2</sub> operation are also being designed and developed.

- A test loop intended for the test of the components has been designed and integrated in the Southwest Research Institute infrastructure. The planned tests bolster the research program.
- The project appears to be addressing critical component technology needs required for operation of a s-CO<sub>2</sub> CSP electric power generation plant. Satisfactory progress appears to have been also made in the thermodynamic-economic cycle evaluation for a future CSP plant.
- It is not clear how the large-scale turbo-expander and test loop will be integrated into existing infrastructure.
- The project deals with only two aspects of the system (turbo expander and heat exchangers). The cost aspect would still be significant. Close clearances due to high pressures will still be needed to achieve the turbo expander efficiencies in the high 80s.
- Significant activity is compressed into Phase 2 and Phase 3 (spanning approximately two years).
- “Novel printed circuit” HX - DMLS and laser welding are two areas that have been worked at for the last several years, and key challenges still remain. More cost analysis and modeling needs to be done to evaluate other manufacturing technologies.



## PROJECT: 5805 SOUTHWEST RESEARCH INSTITUTE

### *Optimizing the CSP Tower Air Brayton Cycle System to Meet the SunShot Objectives*



**FUNDING INFORMATION** \$3.1M | SunShot Concentrated Solar Power Research and Development | 09/2012–01/2015

### Project Description

The objective of the project is to increase the concentrating solar power (CSP) tower air receiver and gas turbine temperature capabilities to 1,000°C by the development of a novel combustor, which can eventually be integrated into a commonly used gas turbine. The 1,000°C temperature target significantly exceeds the 650°C combustor inlet temperatures demonstrated in current Air Brayton CSP projects. The team proposes to achieve this at a reduced scale with emphasis on effects of thermal cycling on hardware and with extremely low emissions.

### Individual Reviewer Comments

- Integrating CSP heat to conventional systems (such as power gas turbines) is a commendable idea. Such demonstrations can pave the way for faster adoption of CSP/solar energy. Combustor is an important part of the hybrid, natural gas/solar system. New combustor design to tackle the very high (1,000°C) inlet air is a technological challenge, as performance and emissions need to be balanced. Use of a novel injector design and combustor design are strengths of the project.
- The project is one among the few being reviewed that might contribute to the SunShot CSP electric power generation goals by 2020.
- This is more like a design/optimization and not a research project. Insufficient details are provided about how the computational fluid dynamic models are to be validated.

- During sun down, only a few burners will be needed. It is not clear what strategy will be implemented to change the number of burners that are online.
- There are other ways of integrating CSP heat with an existing gas turbine power plant (the HiBRED project is one example) by way of thermal storage and inputting the heat at the bottoming cycle. Using the CSP heat input (1,000°C/1,800°F source) for the bottoming (Rankine) cycle seems to be more appropriate. This method eliminates the combustor challenges (high NOx, etc.). In that case, the gas turbine (Brayton) cycle need not be modified. Combustor design is art/science, and to design a combustor for 1,000°C inlet air that meets all other (emission/efficiency/pressure drop) regulations is likely to take long time, as evidenced by the experience of the aviation/power gas turbine industry.

**PROJECT: 5806 MASSACHUSETTS INSTITUTE OF TECHNOLOGY**

*Concentrated Solar Thermoelectric Power*

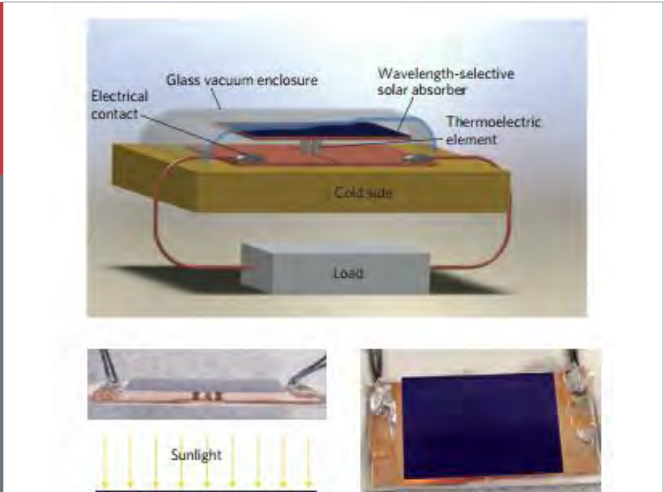

**FUNDING INFORMATION** \$1.0M | SunShot Concentrated Solar Power Research and Development | 09/2012–02/2015

### Project Description

The objectives of this project are to demonstrate concentrating solar thermoelectric generators (CSTEGs) with greater than 10% solar-to-electrical energy conversion efficiency that are capable of 24-hour operation. These objectives will be achieved through developing and demonstrating key components of the envisioned system, including (1) achieving a greater than 10% solar-to-electricity energy conversion efficiency, (2) limiting optical concentration to less than 10x and potentially less than 4x, and (3) demonstrating 24-hour potential through use of phase-change materials. This project builds on existing thermoelectric materials, leverages work conducted through an Advanced Research Projects Agency-Energy (ARPA-E) program on thermal storage materials, and focuses on system demonstration.

### Individual Reviewer Comments

- The project has well-defined goals. In addition, direct conversion holds much promise in terms of simplicity of design, reliability, and modularity.
- The STEG thermoelectric generator concept is highly innovative, but it is also very ambitious—particularly in trying to achieve efficiency greater than 10% for a 24-hour cycle. From a more fundamental standpoint, the project is likely to contribute to the technology base of the country.

- At this point, only model predictions show higher unconcentrated STEG efficiency of 5% or more, which is yet to be validated by experiments. Recent measurements by other researchers have yet to support high-efficiency predictions. The measured results quoted are also for concentrated STEG (“It is predicted that the cavity with our selective surface will achieve 70% receiver efficiency at 500°C with only 19x optical concentration”). The current progress is encouraging.
- The demonstration project has a large number of scientific/technical/economic challenges, including optical design and degradation of optical components with time, radiation properties of materials at high temperature, etc. In view of these challenges, the research project is very risky and is not likely to contribute to the SunShot CSP goal by 2020.
- Achieving efficiencies of greater than 10.0% is challenging, as only 4.6% has been demonstrated.

**PROJECT: 5941**  
**UNIVERSITY OF CALIFORNIA**

*High-Operating-Temperature  
 Heat Transfer Fluids for Solar  
 Thermal Power Generation*



**FUNDING INFORMATION** \$5.0M | Multidisciplinary University Research Initiative: High Operating Temperature Fluids | 10/2012–12/2017

## Project Description

The goal of this project is to develop liquid metals with thermophysical and corrosion properties suitable for use as heat transfer fluids at temperatures above 800°C. The team will employ combinatorial material synthesis and high-throughput characterization techniques together with advanced thermochemical modeling to efficiently identify compositions that are intrinsically less corrosive, or where corrosion can be mitigated through the formation of passivation layers. Scaled flow loop tests will be performed to confirm the effective prevention or mitigation of corrosion. Heat transfer experiments will also be conducted to directly determine the convective heat transfer coefficients as a function of flow parameters and develop engineering models to facilitate optimal design of compact heat exchangers.

## Individual Reviewer Comments

- The plan for achieving performance targets is well-defined. The experimental and theoretical methodologies employed in the project are state-of-the-art. In addition, the use of combinatorial material synthesis, high-throughput characterization, and thermochemical modeling is a unique strength of this proposal.
- The ability to screen a wide range of heat transfer fluids will be very helpful. A comprehensive program is in place to assess heat transfer fluids for various criteria.
- The overall goal of the Multidisciplinary University Research Initiative (MURI)—which includes the University of California, Los Angeles with the University of California, Berkeley and Yale—is to identify/develop liquid metals as high-temperature (up to 800°C) heat transfer fluids for solar-thermal power generation applications. The focus of the project is on thermochemical modeling of molten metal alloy systems, corrosion modeling, testing of candidate systems, and flow loop design and construction. The last task is intended to design and construct a flow loop to measure the convective heat transfer coefficients as function of flow parameters needed for optimal design of compact heat exchangers.
- The specific tasks to be carried out by the collaborating institutions are not identified. For example, it is apparent to this reviewer which investigators have the needed experience and qualifications to perform the convective heat transfer coefficient measurement experiments in liquid metals at high temperatures.
- Accuracy of high-throughput characterization may be limited.
- The screening methodology seems to be the only unique contribution from the project. It is not clear whether the methodology yielded promising candidates so far. If yes, it is important to know how the new material combinations stack up to the leading materials of the day.

## PROJECT: 5942 UNIVERSITY OF ARIZONA

### *Halide and Oxy-Halide Eutectic Systems for High-Performance, High-Temperature Heat Transfer Fluids*



**FUNDING INFORMATION** \$5.5M | Multidisciplinary University Research Initiative: High Operating Temperature Fluids | 10/2012–09/2017

### Project Description

This project seeks to optimize the ternary and quaternary compositions of alkali halides (ionic salts) and metal halides (covalent salts) in an eutectic system in order to develop a high-temperature heat transfer fluid that has a low melting point (250°C), high-temperature (800°C) thermal stability, and favorable thermal and transport properties. Oxy-Lewis acid/base and network-forming additives will be added into the system to reduce the vapor pressure and corrosion, and also to fine tune the thermal and transport properties.

### Individual Reviewer Comments

- The project team has developed a good overall plan of formulation and testing. The key physical and chemical properties are measured.
- Molten Chloride salts are used for heat transfer fluid, as well as storage medium. The work done so far is encouraging. Zinc chloride ( $\text{ZnCl}_2$ ) seems to be the most promising chemical; though, further tests are required.
- The specific objective of this Multidisciplinary University Research Initiative project is to identify proper mixtures of molten salts as heat transfer fluids to meet the target temperatures of up to 800°C for concentrating solar power generating plants.
- The experimental and theoretical methodology employed by the team is state-of-the-art, but it is not clear from the proposal which institution is performing what work.  $\text{ZnCl}_2$  has been identified as a desirable heat transfer fluid because of its acceptable corrosion resistance characteristics. Unfortunately, the thermal conductivity of this fluid is decreasing slightly with temperature, and this is undesirable. It is unclear what the physical reason for this trend is, and what causes the thermal conductivity to decrease with temperature.
- The cost of the project appears to be on the high side, and the criteria for material selection are not clearly defined.
- The project still seems to be in a low Technology Readiness Level as screening studies are ongoing and thermal and other characteristics of selected chemicals need to be fully characterized. Chlorine handling needs to be studied and plans outlined.

## PROJECT: 5954 UNIVERSITY OF COLORADO

### *Using Solid Particles as Heat Transfer Fluid for Use in CSP Plants*

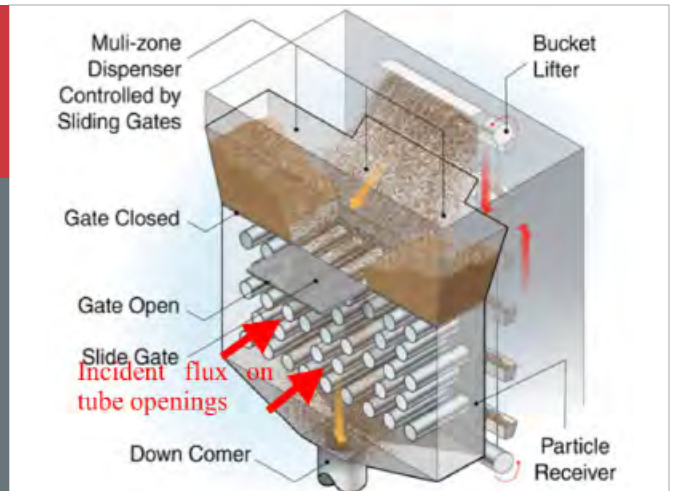

**FUNDING INFORMATION** \$0.5M | Bridging Research Interactions through Collaborative Development Grants in Energy | 02/2013–01/2016

### Project Description

As part of an ultimate goal of developing a commercially viable, transformative method for the design of next-generation concentrating solar power (CSP) plants based on granular media as the heat transfer fluid, the objective of this project is to develop, verify, and validate a first principles modeling tool for use in the optimization, scale-up, and design of a near-blackbody (NBB) receiver. The continuum model will be implemented into the Multiphase Flow with Interphase eXchanges software framework, which is an open-source, cost-free computational fluid dynamics solver for multiphase systems. It will be validated using existing experimental data and discrete-element-method simulations carried out as part of the current effort. Once validated, the model will be used to assist in designing the NBB receiver to achieve the SunShot goal of \$0.06/kilowatt hour.

### Individual Reviewer Comments

- The project features simulations of efficacy of particle-based heat transfer in CSP. Some good preliminary results were shown. The ability of the continuum model relative to the time-intensive discrete model is encouraging. Strengths include a high relevance with excellent prospects of meeting all four technology targets, meaningful impact by utilizing fluid dynamics modeling for solid-gas-wall interactions relevant to the effort, and a meaningful approach to modeling and observing. The funding level is more than appropriate, yielding a significant return on investment.
- Relevance is high, with excellent prospects of heating media to exit temperature above 650°C, at efficiencies greater than 90%, and with a lifetime greater than 30 years. Cost is not addressed; however, the mechanical conveyer of particles and gravity feed through cascading particles offers a good approach to minimizing cost.
- The best approaches include modeling and observing particle flow in the vicinity of round and hexagonal tubes, comparison of hydrodynamics and hydrodynamic instabilities, and the meaningful observation that transfer to solids is more efficient at high flow rates where the packing limit is avoided.
- The project has impact by utilizing fluid dynamics for modeling solid-gas-wall interactions. Utilizing a basic principles approach is sound. However, the project is early-stage work that is hard to assess in terms of any impact to SunShot goals in the timing period. That is why the impact score is lower. Also, applicability in future systems is unclear relative to experiments.

**PROJECT:6345**  
**GE GLOBAL RESEARCH**

*Physics-Based Reliability Models for Supercritical-CO<sub>2</sub> Turbomachinery Components*

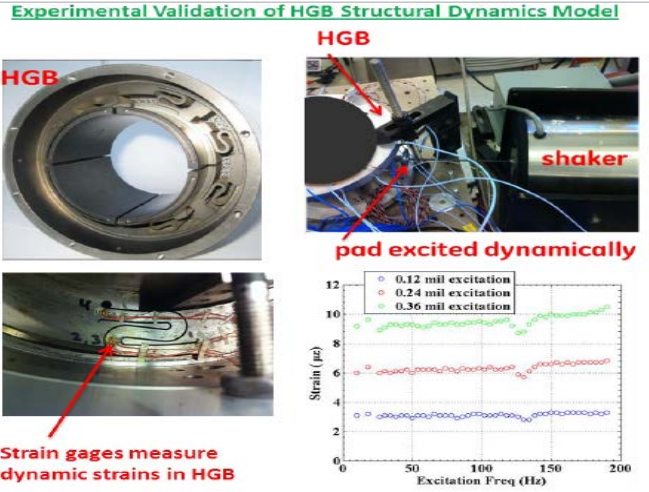

**FUNDING INFORMATION** \$1.9M | Physics of Reliability: Evaluating Design Innovations for Component Technologies in Solar | 10/2013–09/2016

### Project Description

GE seeks to develop a physics-based life prediction and reliability model for hybrid gas bearing (HGB) and dry gas seal (DGS) components. Coupled multi-physics models for performance prediction of these components during a typical supercritical carbon dioxide (s-CO<sub>2</sub>) cycle will be developed in order to generate a loading history that serves as an input to the physics-based lifing model. The coupon-level fatigue and corrosion experiments under a controlled CO<sub>2</sub> environment will be carried out and will provide critical validation of the performance prediction models and provide data that serves as input to the life prediction model. DGS test in a 1 megawatt electrical s-CO<sub>2</sub> loop will validate the performance prediction models and provide key data that serves as input to the life prediction model. A probabilistic framework will be developed to quantify statistical uncertainty and to calibrate and validate the physics-based life model.

### Individual Reviewer Comments

- The project goals and objectives are well-defined. Life prediction models are always a key part of developing reliable engineering systems. However, it is not clear how the physics-based models will be validated.
- The proposed technology developments address only a few issues narrowly for the objectives stated at the outset (compact, tower-mounted s-CO<sub>2</sub> systems). Though the technology developments proposed, such as developing reliability models for HGB and DGS, marginally helps improve the state of technology, it is not resolving key issues for concentrating solar power.

## PROJECT: 6357 ABENGOA

### *Improved Large Aperture Collector Manufacturing*



**FUNDING INFORMATION** \$1.9M | Solar Manufacturing Technology | 09/2013–09/2015

### Project Description

Abengoa Solar will demonstrate new manufacturing and assembly technologies for use in concentrating solar power parabolic trough systems to achieve cost reduction and enable innovative technology to quickly enter the market. This project will focus on highly automated manufacture of trough components, onsite assembly of the troughs at the solar field, and improved quality control using automated inspection.

### Individual Reviewer Comments

- Strengths of the project include an automated approach to fabrication and a lean approach to installation. The concept of a redeployable assembly factory is noted.
- As the industry grows and the economics improve, it is a common sense move to make manufacturing more streamlined, minimizing cost. This project takes good steps toward this goal. As a natural part of progress, financial considerations would drive this forward independent of government funding.
- Best approaches are being utilized in the areas of high-rate fabrication techniques and close-tolerance dimensional accuracy. In addition, eliminating overhead hardware and use of data from previous commercial projects are strengths, and funding is adequate.
- The project is a good continuous improvement effort as opposed to research and development. Funding is rather large, as this is a commercial plant project versus base, shared technology. That said, the project has shown good improvements.
- The effort does not address items such as wind speed durability of the as-produced structures.

**PROJECT: 6534**  
**UNIVERSITY OF FLORIDA**

*Carbon Dioxide Shuttling  
Thermochemical Storage Using  
Strontium Carbonate*

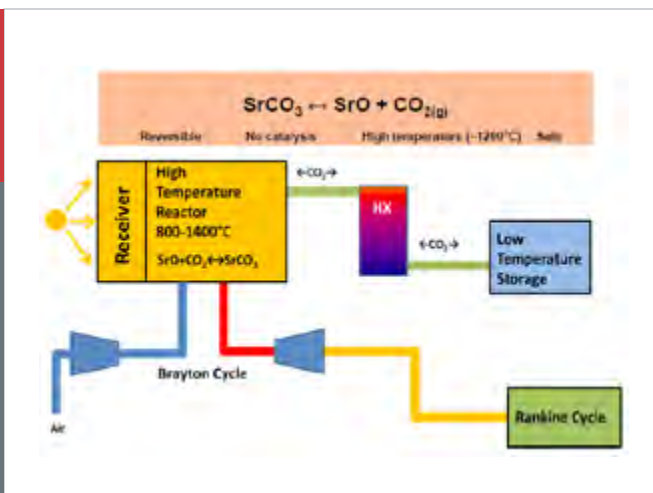

**FUNDING INFORMATION** \$1.0M | Efficiently Leveraging Equilibrium Mechanisms for Engineering New Thermochemical Storage | 05/2014–04/2017

**Project Description**

The objective of this project is to find an economical thermochemical storage solution for concentrating solar power by means of inexpensive, safe, and non-corrosive chemicals. Using a previously unconsidered reaction, chemical bonds are broken using high-temperature, concentrated sunlight. During off-sun periods, the reaction is reversed to release heat at temperatures previously unachievable in other thermochemical, latent, or sensible energy storage schemes. The energy is absorbed by a working fluid such as air and sent to a combine cycle power plant. The laws of thermodynamics dictate that the greater the temperature of a working fluid in a power block, the greater the efficiency of the cycle, making this technology a prime candidate for transformative change.

**Individual Reviewer Comments**

- Project performance targets and deliverables are well-defined. The project has demonstrated a cyclic operation with strontium carbonate with minimal loss of reactivity for 50 cycles. This is quite encouraging as repeatable cycle operation is key to achieving a thermochemical-based carbon dioxide system.
- The thermochemical energy storage concept using strontium carbonate appears to be highly innovative and to have potential of charging and discharging thermal energy at temperatures up to 1,200°C. However, the process dynamics first need to be better assessed and demonstrated.

- The project poster does not provide sufficient information/details concerning opportunities and challenges. For example, it is helpful to know what pore- and macroscopic-level modeling of gas flow and heat/mass transfer are going to be used at high temperatures. It is important to know if there are sufficient experimental data available to do this in a realistic and believable manner.
- It is not clear what the current status of the project is, and the path forward is not defined clearly. In addition, the design of high- and low-temperature reactors would need chemical engineering expertise. It is not clear if the project team has this expertise.
- There are still challenges surrounding reactivity. Repeatability of chemical reactions over numerous cycles remains and has been for similar systems. Though 50 cycles have been demonstrated, repeatability needs to be shown for longer periods. Design of reactors will be a key challenge (dry type or slurry). Fluid handling (e.g., valves) will be a challenge as well.



## PROJECT: 6535 SOUTHERN RESEARCH INSTITUTE

### *Regenerative Carbonate- and Silicate-Based Thermochemical Energy Storage System for CSP*

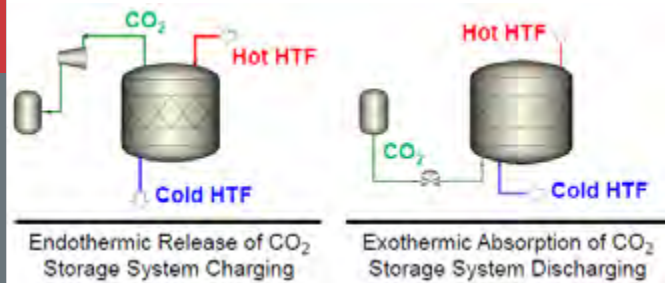

**FUNDING INFORMATION** \$0.9M | Efficiently Leveraging Equilibrium Mechanisms for Engineering New Thermochemical Storage | 05/2014–04/2017

### Project Description

This project seeks to develop thermochemical energy storage (TCES) systems for concentrating solar power (CSP) based on endothermic-exothermic gas-solid reaction cycles at temperatures greater than 650°C. The 24-month project will develop and demonstrate regenerative carbonate and silicate sorbent-based process in a simulated TCES system at bench scale. The project will advance the proposed TCES system from Technology Readiness Level (TRL) 2 to TRL 4 by demonstrating the system's key advantages, its high exergetic and energetic efficiencies, and its potential to meet a cost target of \$15/kilowatt hours of heat.

### Individual Reviewer Comments

- Project goals and plans are well-defined. The project will use relatively cheap and abundant materials that will undergo carbonation/calcination reactions with no side reactions. Kinetics of endothermic and exothermic reactions will be determined experimentally. The key to overall success will be proper design of the calcium carbonate and calcium oxide reactors.
- The concept is relatively simple and has no moving parts. This is an innovative thermochemical energy storage project, but it appears to be quite risky as chemical kinetics, heat, and mass transfer processes at temperatures up to 900°C are not fully understood. The heat transfer fluid to be used is not clearly identified in the documentation.
- The materials to be used are rather common, and so the costs should be modest, but degradation of the materials may be an issue.
- It is unclear as to what is likely to occur after 10,000 cycles. This appears to be a major unknown and will have to be answered by the research team. Thermal cycling may also lead to sintering or particle attrition.
- If oxide particles in form of pellets are used, the reactors may have multiple tubed with fixed bed of particles. The team can benefit from knowledge and expertise of a chemical engineer skilled in reaction kinetics and fixed-bed reactor design.
- As is common in chemical reactions-based energy systems, reactivity and repeatability of chemical reactions over numerous cycles are big challenges. Additionally, design challenges of a solid-gas chemical reaction system also need to be resolved. Both “wet” and “dry” designs carry their own challenges and advantages. Fluid handling of reactants and carbon dioxide (e.g., valves/pumps) will also need to be solved.

**PROJECT: 6536 UNIVERSITY OF CALIFORNIA, LOS ANGELES**

*Thermochemical Storage with Anhydrous Ammonia: Optimizing the Synthesis Reactor for Direct Production of Supercritical Steam*

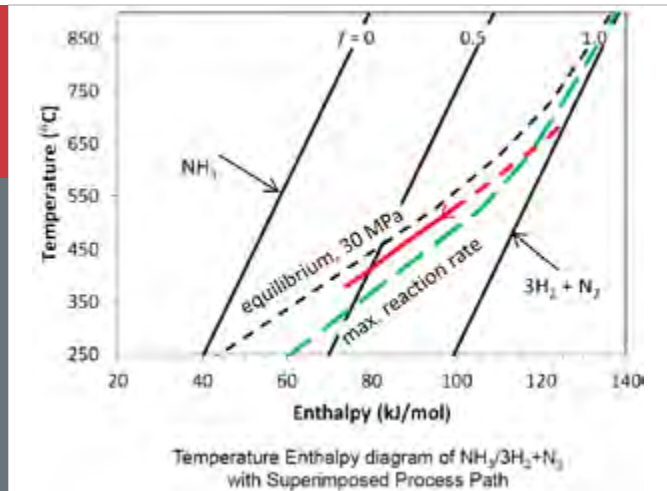

**FUNDING INFORMATION** \$1.2M | Efficiently Leveraging Equilibrium Mechanisms for Engineering New Thermochemical Storage | 05/2014–04/2017

**Project Description**

The team will design and build an ammonia synthesis reactor that is optimized for the direct production of supercritical steam and perform analysis that shows that storage of the energy-rich gas mixture in adapted gas-well systems can deliver the target cost of \$15/kilowatt hour thermal. The proposed research will make significant contributions toward the viability of the ammonia thermochemical energy storage concept and solar thermochemical storage more broadly. By careful optimization of the synthesis reactor and associated heat exchanger, it will demonstrate supercritical steam production at 650°C, a feat which has not yet been achieved for ammonia synthesis. In addition, a cost-effective storage solution for gaseous components will be investigated that could have far-reaching impact for other candidate reactions given the importance of gas storage for a multitude of applications.

**Individual Reviewer Comments**

- The project provides a simpler arrangement for energy conversion. In this proposal, the project team—consisting of the University of California, Los Angeles; IT Power; and Australian National University—will design, build, and test an ammonia synthesis reactor optimized for direct production of supercritical steam at 650°C. The project will also analyze the feasibility of underground storage of hydrogen and nitrogen.

- The production of supercritical steam at 650°C with the ammonia synthesis reactor appears to be the major technological challenge needing to be overcome. This will improve the overall efficiency and minimize energy losses.
- If successfully completed, the project may contribute to the SunShot concentrating solar power generation goals for 2020. It is a high-risk project, but it should be seriously considered for funding.
- Both modeling and experiments will be used to optimally design a pilot-scale synthesis reactor.
- Ammonia dissociation reaction is one of the most studied thermochemical energy systems. Thermodynamics and reaction kinetics are well-known.
- The project approach includes developing a detail reactor model and doing experimental work. However, it is not clear from the poster which part of the work will be performed at the University of California, Los Angeles and which by the two collaborating organizations.
- There is a possibility of tube-to-tube variations in multi-tubular packed bed ammonia synthesis reactor. This may lead to hot/cold spots in the reactor, thus affecting reaction conversion.
- Temperature in the synthesis reactor is the most important variable. Achieving 650°C is critical to overall heat recovery as direct superheated steam. In addition,

commercial catalysts for ammonia synthesis have been known to be stable up to 550°C. Catalyst deactivation and/or sintering at about 650°C may become important and is not addressed.

- The team lacks expertise in chemical engineering. The design of high-temperature synthesis reactor would benefit from a chemical engineer with expertise in reaction kinetics and fixed-bed reactor design.
- Though chemically feasible, ammonia cycle has many issues in handling the working fluid. Just like other chemical systems, reactivity, repeatability of chemical reactions over numerous cycles are issues/challenges, and handling ammonia means design challenges for the components. Safety hazards and environmental issues need to be addressed.

**PROJECT: 6537**  
**COLORADO SCHOOL OF MINES**

*High-Temperature Thermochemical Storage with Redox-Stable Perovskites for CSP*

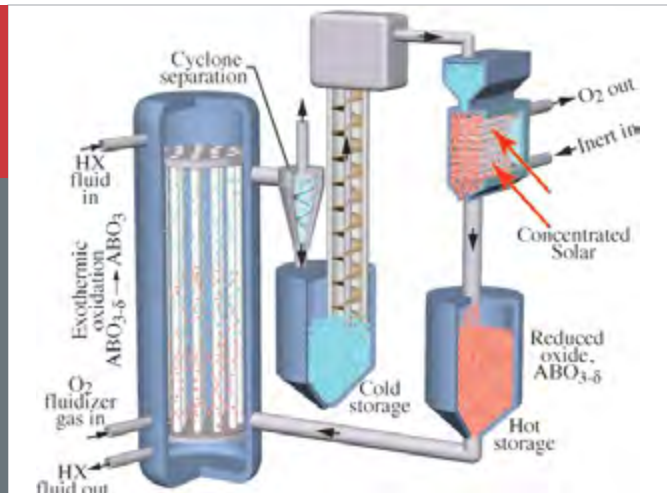

**FUNDING INFORMATION** \$1.0M | Efficiently Leveraging Equilibrium Mechanisms for Engineering New Thermochemical Storage | 05/2014–04/2017

**Project Description**

This project will explore the techno-economic feasibility of redox cycles with low-cost, perovskite oxides for high-temperature thermochemical energy storage (TCES) in a concentrating solar plant. Perovskites (chemical structure  $ABO_{3-\delta}$ ) can undergo endothermic reduction to store energy at temperatures as high as  $900^{\circ}\text{C}$ . The stored energy can be released by exothermic re-oxidation to provide high-temperature heat exchange to drive high-efficiency power cycles, such as supercritical carbon dioxide. Combined thermochemical and sensible energy in the partially reduced perovskites already identified can provide storage of 750 kilojoule/kilogram or more (with 60% coming from TCES) such that less than 1.5 cubic meters of particles can be re-oxidized to produce 1 megawatt hour of electricity for a 50% power cycle.

**Individual Reviewer Comments**

- Although this project is just getting started, program objectives and deliverables are well-defined. One advantage is that the project team is collaborating with the National Renewable Energy Laboratory’s (NREL’s) near-blackbody receiver. The team can leverage NREL’s results, thereby avoiding duplication of effort.
- The study is to investigate Perovskites for higher density and better operating range for TCES. Oxides have inherent advantage, as the working fluid is oxygen.

- The screw conveyor lifting cold particles to the falling particle receiver is likely to have operational problems. The research group should look for alternatives to moving the particles up. In addition, the challenges associated with chemical kinetics, heat, and mass transfer issues in porous materials at high temperature do not appear to be fully recognized by the research team.
- This is a highly innovative TCES project, but the risks do not appear to have been fully identified by the project team. Even if completed to the extent planned, the research findings are not likely to contribute to the SunShot Concentrating Solar Power electric power generation goals by 2020. In addition, demonstrating multiple redox cycles with stable performance will be key to success.
- Released oxygen from the endothermic (heat absorption) phase is not stored and reused for exothermic reaction (combining with the reduced Perovskites) to release heat energy as air is used for the exothermic reaction. Has the additional “costs” of using air instead of oxygen that was generated studied in detail as more air has to be used and higher-power fluid handling equipment is necessary? Chemical characterization, reactions, and reactor design are at an early stage.

## PROJECT: 25682 ARGONNE NATIONAL LABORATORY

### *High-Efficiency Thermal Energy Storage System for CSP*

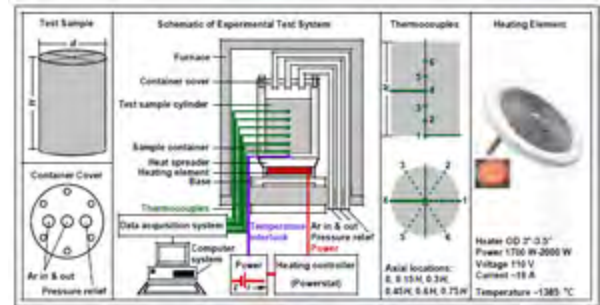

**FUNDING INFORMATION** \$2.2M | National Laboratory Research and Development | 10/2012–09/2015

### Project Description

The goal of this proof-of-concept project is to develop an efficient, high-temperature, laboratory-scale thermal energy storage (TES) prototype by utilizing advanced phase change materials (PCMs) in combination with new, high-conductivity graphite foams. The laboratory-scale prototype TES system will be built and tested with the purpose of gathering performance data (e.g., transport properties, system durability, and thermal cycling) regarding a combination of PCM mixtures and foam types and densities. In addition, associated technologies needed for scale-up and practical implementation will also be developed. These include the process to infiltrate the foams, coating the foams for strength and environmental (oxidation/corrosion) durability enhancements, and joining techniques for system integration.

### Individual Reviewer Comments

- This is a proof-of-concept technology development project. The focus is not on fundamental understanding of engineering/technology concepts, but on validation of the PCMs based latent heat energy storage system. At the same time, the principal investigators are addressing practical implementation, joining techniques, challenges, etc.
- Use of highly porous metal foams filled with PCMs is a unique feature of this project. More capable energy storage materials are key to improving the state of energy storage technology, which is currently done with molten salts. A detailed study of PCM candidates has been started.
- The project team uses state-of-the-art experimental and theoretical methodologies to obtain data needed to demonstrate the latent heat TES performance and design/develop a prototype system. One of the very important thermophysical properties that strongly influences the charging and discharging characteristics of the system is the thermal conductivity of the graphite foam impregnated with the PCM. Unfortunately, the thermal conductivity is seen to decrease with temperature, and this is not desirable. It is unclear if the research team has sufficient physical understanding of the heat conduction and radiation (at high temperature) phenomena in the graphite-impregnated foam at high temperature to design/model the system.
- The team is trying to address a large number of technologically challenging issues at the same time; however, maybe the time frame imposed by the SunShot Concentrating Solar Power program forces this approach on them.
- It is not clear how the various models will be validated. In addition, repeated thermal cycling may alter the porosity of the foam or may lead to separation of PCM from the voids.
- It is unclear how the combination of graphite foam plus magnesium chloride were arrived at and what process was used to screen potential candidates. Many technology barriers exist and are outlined in the summary. At this point, the technology is at a low Technology Readiness Level. However, the progress so far is encouraging.

# PROJECT: 25683 SAVANNAH RIVER NATIONAL LABORATORY

*Fundamental Corrosion Studies in High-Temperature Molten Salt Systems for Next-Generation Concentrated Solar Power Systems*

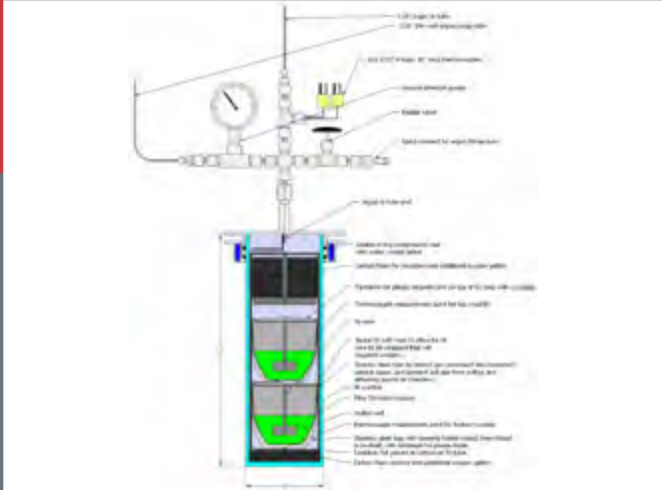

**FUNDING INFORMATION** \$3.8M | National Laboratory Research and Development | 10/2012–09/2015

## Project Description

Savannah River National Laboratory seeks to improve materials durability in concentrating solar power (CSP) systems in the presence of high operating temperature (HOT) heat transfer fluids (HTFs) for use in advanced power production processes. Improvements in materials durability will be achieved via an integrated experimental and numerical approach that will identify optimal combinations of HOT HTFs with materials of construction and corrosion protection schemes that maintain the HTFs good heat transfer properties, achieve low corrosion rates, and indicate good performance in CSP system simulations. This objective will be achieved by combining (1) experimental determination of corrosion rates in model HOT HTF systems and identification of critical parameters of corrosion mechanisms, (2) thermodynamic property modeling for HOT HTFs, (3) risk-mitigation methods for the identified corrosion mechanisms, (4) demonstration of the effectiveness of corrosion mitigation methods, and (5) modeling of corrosion in heat transfer systems.

## Individual Reviewer Comments

- The project aims to improve material durability by reducing corrosion due to next-generation HOT HTFs. This is key to durability and reliability of CSP systems.

- This is a fundamental corrosion study intended to gain understanding of heat transfer systems at temperatures above 850°C using molten salt HTFs. The primary objective is to identify corrosion-resistant materials and to improve their durability in CSP systems. The overall plan of integrating experimental research and using a numerical approach has a good chance of identifying the appropriate HOT HTFs.
- The project is to be carried out at Savannah River National Laboratory with the collaboration of the faculty members from the University of Alabama and the University of South Carolina. This project would benefit if the team members interacted with other groups dealing with corrosion and molten salt systems.
- It is not clear how the fluid flow and thermal gradients computational fluid dynamic models will be validated.
- The effort is very important to mitigate corrosion due to HOT HTF, but at the same token, as materials are being developed for HOT HTF, it is difficult to study all potential combinations. The team needs to identify fundamental mechanisms that contribute to corrosion and need a quick screening methodology to come up with potential coating materials/cathodic protection or other mitigation techniques. Certain key combinations were studied, which is a good start.

## PROJECT: 25745 OAK RIDGE NATIONAL LABORATORY

### *Low-Cost, Self-Cleaning Reflector Coatings for CSP Collectors*



**FUNDING INFORMATION** \$2.3M | National Laboratory Research and Development | 10/2012–09/2014

### Project Description

Oak Ridge National Laboratory is developing self-cleaning, optically transparent coatings that can be applied to the surfaces of heliostats and collector mirrors in concentrating solar power (CSP) systems. The goal is to reduce the time and costs associated with cleaning collector and heliostat mirror surfaces and increase the reliability and efficiency of CSP systems. The research team has developed optically transparent superhydrophobic (SH) materials and coatings based on nanostructured silica surfaces that can address soiling and maintenance issues associated with CSP systems. The team is investigating and optimizing the adhesion, transmittance, and water- and dirt-repellent properties of these multifunctional, nanostructured surface coatings, and is using a suspension of SH silica nanoparticles, polymeric binders, and solvents that can be applied to large area surfaces using simple, low-cost spray coating techniques developed by the commercial paint industry.

### Individual Reviewer Comments

- This is an important, cost-saving coating technology being developed. The team demonstrated good results on self-cleaning and antireflection properties, and commercialization is being considered. Strengths of the project include observed improvement in abrasion/coating durability; compliance with volatile organic compounds; a scalable, semi-automated spray coating system; and establishment of a manufacturing partner. Use of design of experiments is noted. Use of a contemporary clearcoat matrix with automotive heritage is a plus.
- There are two solar field goals: reduced cost and reduced soiling. Figure 1A demonstrates a 20–100 fold improvement in abrasion resistance. An improvement of 2%–3% in transparency is a plus.
- Best approaches appear to be utilized to a great extent—e.g., scanning electron microscope (SEM), profilometry, and salt fog and accelerated UVA testing. Uniform particle size is noted in SEM photographs. Single abrasion passes are used as a metric. Funding is also adequate.
- This is a continuing key research area. However, most projects do not objectively calculate the resultant costs of still needing a cleaning protocol, equipment, and (reduced) frequency to model the initial and ongoing cost as the coating wears out. Industry needs to address the basic technology challenge nonetheless.
- The project needs additional initial costs of application. There is good research activity, but there needs to be some guidance on total cost: material, equipment, and labor. This is really the figure of merit versus the operating cost in the leveled cost of energy equation. For some experiments, multilayers were used. These tend to have issues under long-term thermal cycling.
- The abrasion duration improvements are not tied to a 30+-year lifetime prediction, and the accelerated UV exposures are not tied to a 30+-year lifetime prediction.

**PROJECT: 25828 LOS ALAMOS NATIONAL LABORATORY**

*High-Temperature Thermal Array for Next-Generation Solar Thermal Power Production*

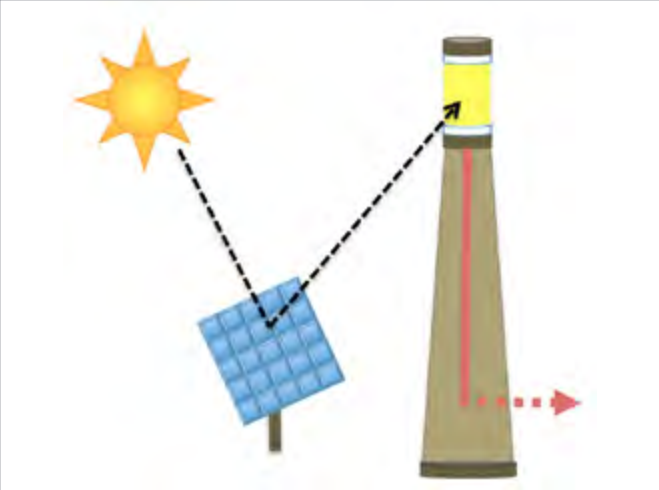

**FUNDING INFORMATION** \$2.0M | National Laboratory Research and Development | 12/2012–11/2015

### Project Description

Los Alamos National Laboratory is developing a megawatt-scale heat pipe-based technology designed to bridge the heliostat reflector field and the power cycle by replacing both the solar receiver and the heat transfer fluid system used in existing concentrating solar power (CSP) systems. Major technical aspects of this work are focused on cost-effective wick composition, thermal array fabrication methods, counter gravity physics, heat pipe start-up and thermal cycling protocols, and system testing and scaling for large-scale deployment.

### Individual Reviewer Comments

- This project is to develop a heat pipe system that combines solar energy receiver and heat energy transport (eliminating heat transfer fluid transfer system), thus enabling lower costs. This is a significant departure from the conventional CSP system and brings its own reward commensurate with the risk. The technology development plan is well-defined. Use of heat pipes is also a novel feature of this proposal.
- This is a highly innovative extension (and utilization) of an old heat pipe technology concept for CSP power generation to towers operating up to 1,200°C. While it is not a fundamental technology development project, it is quite challenging. The project involves developing scaling relationships (from 1 megawatt [MW], to 10 MW, to 100 MW) for very long (up to 300 feet) countergradient heat pipe (HiTTA) array.

- This is an innovative but high-risk project. If confirmed, the HiTTA array may make a significant impact in meeting the SunShot CSP power generation goals, but not by the envisioned 2020 time frame.
- The test bed system design and operation is not only highly desirable, but essential to confirm/validate the HiTTA array expectations before proceeding further with the project.
- Heat pipe is a technology that has been around for a while, but which continues to have significant technical challenges (evaporation, wicking, and condensing). Large-scale (300 feet) heat pipes bring additional challenges. The progress made so far is encouraging, but still much work needs to be done. In addition, the path forward is not defined.



## PROJECT: 25829 NATIONAL RENEWABLE ENERGY LABORATORY

### *Degradation Mechanisms and Development of Protective Coatings for TES and HTF Containment Materials*

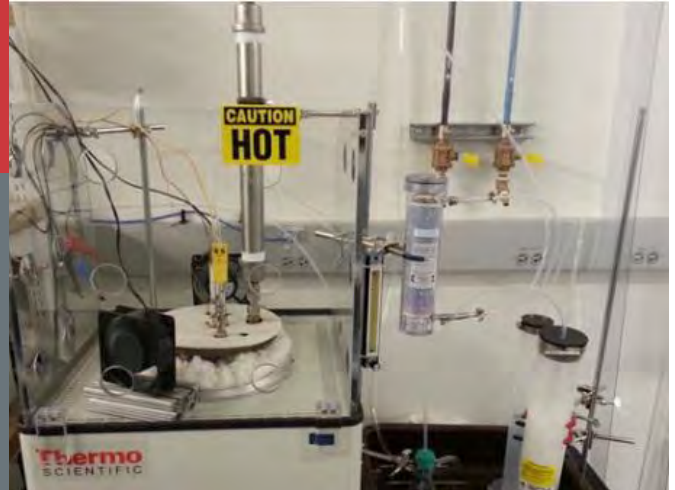

**FUNDING INFORMATION** \$3.2M | National Laboratory Research and Development | 10/2012–12/2015

### Project Description

The National Renewable Energy Laboratory is working to extend the lifetime of containment materials and reduce the capital and maintenance costs of future solar power plants. Advanced protective coatings and surface modification techniques will be developed and evaluated to yield degradation rates lower than 30 microns per year. The objective is to develop and validate material systems and protective conditions that increase the lifetime of heat transfer fluids (HTFs) and thermal energy storage (TES) systems containing materials at temperatures of 600°C to 900°C. For molten salts, electrochemical techniques will be employed to understand and control the corrosion mechanisms; while for liquid metal alloys, immersion degradation will be evaluated. For supercritical carbon dioxide (s-CO<sub>2</sub>) attack, autoclave and flow tests will be used. Coatings containing nanomaterials like graphite and alumina will be evaluated for this purpose.

### Individual Reviewer Comments

- The evaluation and testing of materials systems is one of the strengths of this proposal. The plan includes use of electrochemical techniques to understand corrosion, autoclaves for s-CO<sub>2</sub>, and use of density functional theory calculations to provide microscopic understanding.
- This is a detailed study of protective coatings against corrosion and other degradation for potential working fluids (s-CO<sub>2</sub>, molten salts) in CSP systems. Corrosion resistance is a very important aspect for the reliable operation of any such energy system. Candidate materials for molten salts and corrosion in s-CO<sub>2</sub> are studied.
- If molten salts and s-CO<sub>2</sub> are to be used as TES media and HTFs, respectively, understanding of the degradation of materials used in TES and HTFs is essential. The researchers use accepted/proven methodologies to study coatings and corrosion of materials in molten salts and s-CO<sub>2</sub>.
- Physical vapor deposition and plasma spray techniques may result in non-uniform thickness of coatings. This will make the selection of the appropriate materials more difficult.
- Economic feasibility, including method of manufacturing, ease of application, and availability of the coating materials, are all key to successfully implement the material systems selected. The team needs to make a preliminary investigation with respect to this aspect. In addition, though this is a valuable, long-range materials development project, it is not likely to have a significant impact on SunShot 2020 Concentrating Solar Power cost goals.

## PROJECT: 25830 NATIONAL RENEWABLE ENERGY LABORATORY

*Low-Cost Heliostat for Modular  
Systems*

**FUNDING INFORMATION** \$2.2M | National Laboratory Research and Development | 10/2012–06/2014

### Project Description

The National Renewable Energy Laboratory seeks to develop a novel collector design and heliostat field technologies that reach the SunShot Initiative cost and performance targets. This includes optimization of an efficient low-profile rigid collector design, implementation of inexpensive wireless communication and control devices to reduce field wiring, and development of an automated optical tracking/calibration technique that enables the use of lower-cost motor and drive components through improved error correction. This design will be optimized, prototyped, tested, and transferred to industry during the three-year period of performance.

- Wiring costs are driven by power levels, so the communication and drive power should be modeled together.
- Weaknesses include a basic premise of upfront savings with the risk of network difficulties later during the operational phase and the use of a probabilistic cost model.
- The project outline covers drive error correction, but the documents do not seem to be of that aspect. In addition, there are many fluctuating parameters in the cost basis. These designs are probably more precisely estimated in the plant design phase; hard to formulate—the results show large ranges of optimal groupings.

### Individual Reviewer Comments

- Heliostat field control issues are addressed with the view toward wireless versus wired and is a practical concern for future systems. The solar field goal addressed is efficient tracking and control methods via a shared-node control, leading to reduced installation costs.
- Strengths of the project include a straightforward approach to identify installation cost utilizing material and labor; a concept that is most relevant for power (communication benefits are marginal); and the project’s impact is in reduced costs obtained at the time of installation (which may be offset by network difficulties later during the operational phase).
- The project covers a key area in collector field cost. In addition, the level of funding is fair, as power was considered in overall cost. The best approaches being used include a fair approach to estimating costs by estimating labor and materials and cost modeling.

## PROJECT: 25831 NATIONAL RENEWABLE ENERGY LABORATORY

### *SAM Enhancements for CSP*

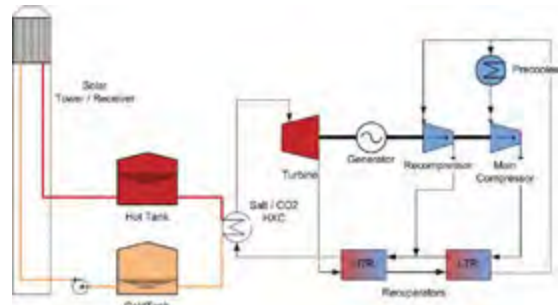

**FUNDING INFORMATION** \$0.6M | SunShot Concentrated Solar Power Research and Development | 10/2012–09/2015

### Project Description

This project will leverage recent System Advisor Model (SAM) kernel improvements by developing a robust tool specifically designed for concentrating solar power (CSP) systems. This work will enable simulations of more complex plant control algorithms and receiver, field, and storage models optimization codes while providing a standardized interface to streamline modeling efforts. The team will also develop and validate detailed high-temporal-resolution models. These models will support CSP grid integration simulation and analysis efforts performed by other centers at the National Renewable Energy Laboratory. They will also help inform optimal plant operation strategies and aid in the analysis of material thermal cycling. Finally, the team will develop models for advanced power cycles and hybrid plant designs that have been proposed for CSP systems. These innovative power cycles are potentially higher-efficiency and lower-cost alternatives to current CSP cycles.

### Individual Reviewer Comments

- This project has some useful power delivery predictive functions. The project has a good funding balance versus benefits. The team might need to explore additional hybridization models and modular configurations near term. Overall, this is a good project.
- Best approaches seem to be utilized, including new functionality for an integrated solar combined cycle, solar field optimization, the supercritical carbon dioxide power cycle, and a customer performance feature. Not included is an effort on particle-based media.
- This project is also a good upfront investment for predicting system performance, yielding cost reductions in the long run. The effort is not specifically relevant to optical error analysis, wind speed, or 30-year lifetime.
- The effort has impact to costs via system-level performance. Funding is also adequate.

## PROJECT: 25832 NATIONAL RENEWABLE ENERGY LABORATORY

### *Direct S-CO<sub>2</sub> Receiver Development*

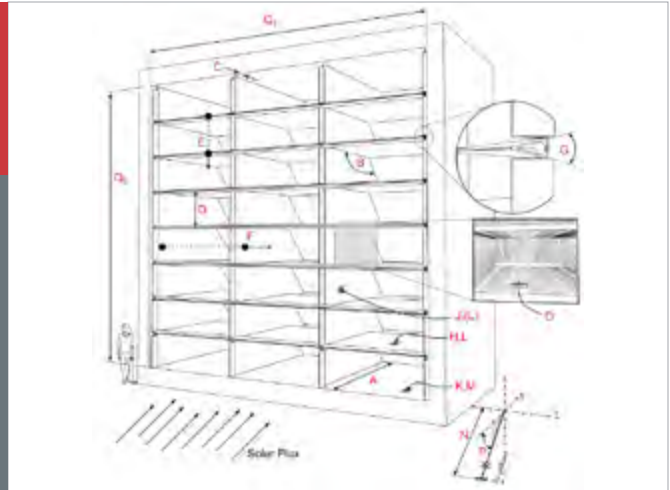

**FUNDING INFORMATION** \$2.6M | National Laboratory Research and Development | 10/2012–8/2015

### Project Description

The National Renewable Energy Laboratory seeks to develop, characterize, and experimentally demonstrate a novel high-temperature receiver technology using supercritical carbon dioxide (s-CO<sub>2</sub>) directly as the heat transfer fluid. To be considered successful, the commercial technology must achieve the SunShot receiver targets of greater than 90% thermal efficiency while heating the CO<sub>2</sub> to 650°C. The commercial receiver will also be able to withstand 10,000 thermal cycles before mean-time-to-failure and have an expected commercial cost of less than \$150/kilowatt thermal. A prototype receiver system will be constructed and tested to validate the performance model that will be used to develop the commercial receiver design. They will also characterize multiple direct receiver concepts, disseminate the results to industry, and produce a set of modeling tools and methodologies that can be used by other parties to deploy direct receiver technologies for s-CO<sub>2</sub> systems.

### Individual Reviewer Comments

- This is an important project with high relevance to solar energy development. Strengths include an indication that currently available engineering materials and a novel geometric approach meets or exceeds goals of exit temperature, thermal efficiency, and lifetime.
- The project offers three clear strengths in relevance: (1) suitable laboratory-scale studies, (2) an on-sun prototype, and (3) performance modeling—all leading to objectives common with the receiver and heat transfer

fluids technical targets. The project also offers substantial impact to Concentrating Solar Power goals, with every indication of successfully reaching exit temperature, thermal efficiency, and lifetime cycle target values.

- Best approaches are being utilized, as indicated by initial model-based prediction of concept feasibility. The funding level is ideal, and the team is making excellent progress.
- The team has a good approach and cost reduction versus other s-CO<sub>2</sub> is likely, but it would be good to see some estimates on cost in absolute terms.
- There is a good absorption efficiency tradeoff.
- It is hard to assess project phase impact in terms of what was really expected from this phase versus statements that it would meet those goals from the write-up. The poster file could not be opened ahead of time. Similar scoring for approach in that the write-up states that model and proto receiver design will be built, but it is hard to determine where that will place the project along the path toward SunShot goals versus the funding identified. Cost remains uncertain.
- Minimal quantitative performance data were given.

## PROJECT: 25834 SANDIA NATIONAL LABORATORIES

### *Dish Stirling High-Performance Thermal Storage*



**FUNDING INFORMATION** \$2.4M | National Laboratory Research and Development | 10/2012–09/2015

### Project Description

This objective of this project is to demonstrate the key components of a thermal storage system for dish Stirling power generation. The thermal storage system features latent heat transport and latent heat storage, which is an optimal combination with the isothermal input of Stirling engines. This combination minimizes thermodynamic energy and exergy losses. The resulting subscale demonstration should be sufficient to interest partners in the manufacture of dish Stirling systems with storage. This system will provide up to 6 hours of storage on a 25-kilowatts electrical Stirling system. The storage and the engine are both moved to the rear of the dish. This placement provides an optimum balance of the dish system, reduces cantilevered weight, and allows closing of the “pedestal gap,” leading to efficient structural designs. The size and duration of the proposed embodiment will enable sufficient storage on utility-scale dish Stirling deployments.

### Individual Reviewer Comments

- The partnership between Sandia National Laboratories, the National Renewable Laboratory (NREL), and the University of Connecticut (UCONN) is one strength of this proposal. Sandia will perform heat pipe testing, NREL will characterize high-temperature phase change materials (PCMs), and UCONN will provide modeling of freeze-thaw cycles.
- PCM (storage subsystem) design is a critical aspect of improving the Dish-Stirling engine performance to meet SunShot goals. A detailed study of PCM system has been started.
- This is a more near-term project that could impact the SunShot Concentrating Solar Power target performance goals by 2020.
- The key findings have been clearly summarized, and future work has been identified. This includes both coating development and demonstration of both key components, as well as on the system level.
- Testing with potential shell materials indicated acute interactions between the PCMs and containment. This may potentially affect the economics.
- Though one of the greatest strengths of a standalone Stirling engine is its modularity as energy transport is localized, efficient energy conversion and storage are contained in a single Dish-Stirling system, the same could be a weakness as all subsystems need to work together, which creates multiple points of failure. Robust design and reliability studies need to be conducted to overcome such concerns.

## PROJECT: 25835 SAVANNAH RIVER NATIONAL LABORATORY

### Low-Cost Metal Hydride Thermal Energy Storage System for CSP Systems

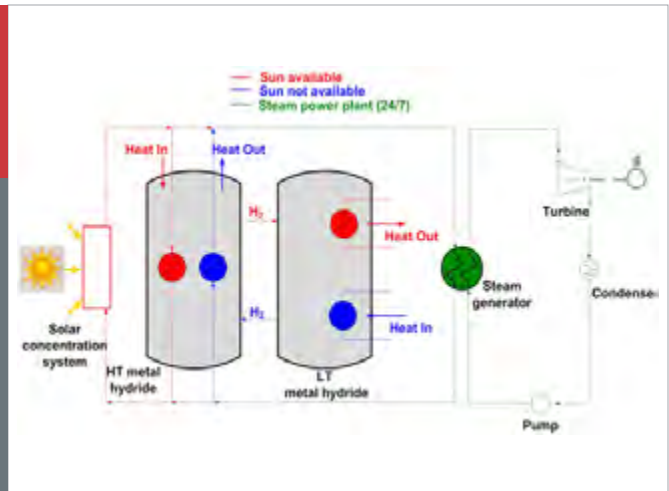

**FUNDING INFORMATION** \$2.5M | National Laboratory Research and Development | 10/2012–09/2015

### Project Description

The objective of this research is to evaluate and demonstrate a metal hydride-based thermal energy storage (TES) system for use with a concentrating solar power (CSP) system. The team's unique approach makes use of a hierarchical modeling methodology that combines modeling experience and material knowledge to screen several promising metal hydride candidate materials and select the best candidates for more thorough evaluation through experiments and more detailed models. During the second year, material optimization, bench-scale testing, and more detailed component and system models will lead to a proof-of-concept demonstration and a preliminary system design. The culmination of this proposed research will be the design, fabrication, and evaluation of a prototype metal hydride energy storage system that aims to meet SunShot cost and performance targets for TES systems.

### Individual Reviewer Comments

- TES is one of the critical elements of CSP, and the present research is to identify high-temperature TES materials. Project objectives and cost targets are well-defined. There is also good integration of modeling and materials development efforts.
- This is not a highly innovative project, but it is reasonably well-defined. It involves integration of modeling and materials development, but the risks do not appear to be fully recognized.

- The effective thermal conductivity is an important thermophysical property, but the project team does not appear to have a good handle of this property at high temperature.
- Even if successfully completed, the research findings are not likely to contribute to the CSP electric power generation goals by 2020.
- If scale-up to the commercial scale is required, the team does not have this expertise. The project would benefit from someone who is skilled in reaction kinetics and reactor design like a chemical engineer.
- As is common to chemical systems working on endothermic heat absorption and exothermic heat release, material reactivity, repeatability of chemical reactions over thousands of cycles, kinematic speeds are significant issues and challenges.
- Reactor design and working prototype are at an early stage. A working prototype with high- and low-temperature reactors is needed to fully assess the repeatability of the cycles.
- There are additional challenges for hydrogen as a working fluid (design of components, leak proofing, etc.) that need to be assessed against the cost. Progress so far is encouraging.

## PROJECT: 25837 SANDIA NATIONAL LABORATORIES

### *The DOE National Solar Thermal Test Facility*



**FUNDING INFORMATION** \$2.5M | National Laboratory Research and Development | 10/2012–09/2015

### Project Description

This funding ensures that capabilities at the National Solar Thermal Test Facility (NSTTF) are maintained, operational, and safe for researchers and industrial partners to utilize to achieve their scientific and business goals. The facility enables researchers in their study and benchmarking of subsystem performance on-sun at high flux, power, and thermal levels in the pursuit of U.S. Department of Energy (DOE) SunShot goals. Activities at the NSTTF include the testing of novel, high-temperature solar receivers up to 6 megawatt thermal using the newly refurbished heliostat field; testing of prototype solar central receivers and associated components, such as heat shields; evaluation of individual heliostat reflected beams with a Beam Characterization System (BCS); and evaluation of low-flux beams from customer-provided heliostats, which will help reduce the cost of the heliostats—the most expensive part of a concentrating solar power (CSP) plant.

- The proposed plan is sound. The project is a clear asset to moving CSP/solar energy technology forward.
- Details on what has been accomplished are very limited. This project seems to be under-funded. More money should be allocated to this project, as it will be used by many projects. As it stands, replacement cost is prohibitive.
- As NSTTF is an old facility, it requires a lot of upkeep. It is not clear how much users/partners are bringing to the table to validate their technologies. The team needs a strategic plan tailored to take advantage of the true strengths of the facility.

### Individual Reviewer Comments

- DOE's NSTTF provides a state-of-the-art platform for government laboratories and industry and a large-scale environment for testing photovoltaic and CSP technologies. Its key partners include a large number of U.S. government organizations, universities, nonprofit organizations, laboratories, and foreign entities. The NSTTF is an essential national resource and needs to be supported.

## PROJECT: 25838 SANDIA NATIONAL LABORATORIES

### *High-Temperature Solar Selective Coating Development for Power Tower Receivers*

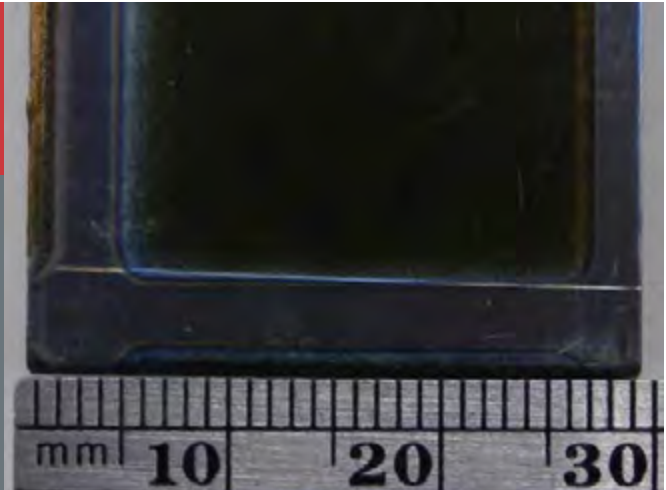

**FUNDING INFORMATION** \$2.6M | National Laboratory Research and Development | 10/2012–11/2015

### Project Description

Sandia National Laboratories will develop solar selective coatings for next-generation power tower applications that exhibit high absorptance with low thermal emittance, surpassing the performance of the current benchmark material, Pyromark. These materials will be stable at high temperature (greater than or equal to 700°C) in air, have high thermal conductivity, and be nonvolatile. The team will develop deposition methods that can be scaled-up to practical sizes. The team will also conduct durability testing of promising materials deposited on receiver metal substrates in conventional thermal furnaces, solar simulators, and on-sun to understand the degradation mechanisms and improve stability under realistic simulated environments.

### Individual Reviewer Comments

- This project is a very good study of the balance between absorbance and emittance, especially at high temperatures. It is a challenging task. Strengths include a careful deposition and characterization of coatings, stability of coatings to the use environment, and a fair approach for minimizing costs. Best approaches include sound laboratory work leading to careful deposition and characterization of coatings, and producing coatings that are stable at the desired temperatures.

- The impact of the project is in the methodical approach for developing state-of-the-art solar selective coatings, including compatible target materials, thermal spray for scale-up, and careful control over thicknesses. Funding is appropriate.
- The project has a good approach and impact relative to combination of effects defined. However, the emphasis on life and re-coating is a concern and should be better explored, as noted in the review, given its significant cost impact over time.
- Cost elements are not readily identifiable for a \$2.5 million project and could be better outlined to help determine funding effectiveness. Overall, cost tradeoff numbers at the system-level would be helpful.
- Weaknesses include a challenge to demonstrate longevity at operating temperatures and the thermal cycling environment. In addition, multilayer stacks are prone to delamination on thermal cycling.



## PHOTOVOLTAICS

This activity area encompasses research that has the potential to dramatically lower costs and/or increase efficiencies of PV modules beyond the SunShot targets of \$0.50/W and 20%, respectively. It includes early stage, applied research on new materials and device structures funded through the Next-Generation Photovoltaics 2 (NextGen 2) and BRIDGE programs, as well as national laboratory R&D. The research supported by these programs will facilitate the entry of novel competitive technologies into the PV marketplace.



Steven Bohn, an engineer at SunEdison oversees SunEdison's testing facility at SolarTAC in Aurora, Colorado. SunEdison is an Original Founding Member of SolarTAC.

Photo credit: Dennis Schroeder / NREL

The Photovoltaics (PV) program funds research and development that is critical to continued advances in solar cell and module technology. These advances enable lower costs, increased efficiency, and improved reliability to support the widespread deployment of electricity produced directly from sunlight ("photovoltaics"). The PV portfolio includes research directed toward the SunShot Initiative goals, as well as critical challenges beyond SunShot.

### PV Overview

To meet the SunShot Initiative goal of an unsubsidized utility scale PV system cost of \$1/W and to attain a levelized cost of energy (LCOE) of \$0.06/kWh by 2020, the PV program has the following targets for modules with a 30-year lifetime:

- Module cost of \$0.50/W (including margin)
- Module efficiency of 20%.

While module costs have decreased dramatically since the start of the SunShot Initiative, an additional one-third cost reduction is necessary. Increases in module efficiency enable decreases in the BOS costs (Figure 6).

As the goals of the SunShot Initiative come within sight, the PV program aims to address the next generation of challenges to support increased PV deployment, including further reductions in the cost of PV electricity, as well as reliability and life-cycle sustainability. We also support the development of a skilled and diverse workforce of researchers prepared to address current and future challenges in the PV field. Accordingly, the PV portfolio spans work from early stage solar cell research until the point of commercialization. It includes work on materials, processes, and device structure and characterization techniques. Just a few examples of our

Figure 6: Evolution of the component costs of a PV system over time, also showing the SunShot targets and future reductions beyond SunShot

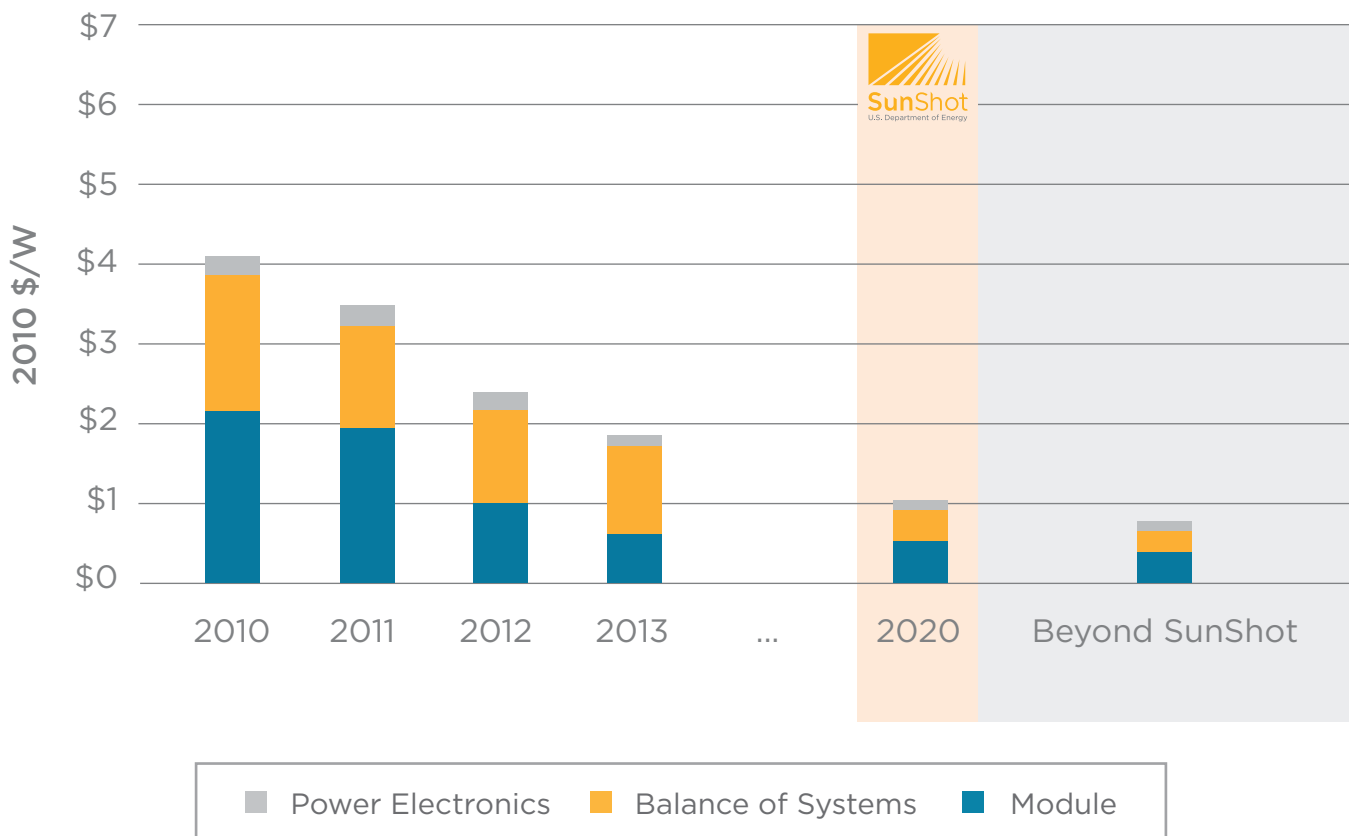

projects include a combinatorial approach to find new earth abundant absorber materials, new silicon solar cell structures using organic and metal oxide heterojunctions, high efficiency III-V on Si multijunction solar cells, the development of a two-photon

photoluminescence technique to separate bulk and surface lifetimes in thin films, and model systems for Cadmium telluride (CdTe) and Copper zinc tin sulfide (CZTS) solar cells to probe fundamental efficiency limits.

The PV program helps to maintain U.S. leadership in PV R&D, with a strong record of impact over the past several decades. For example, over one-half of the solar cell efficiency records on the National Renewable Ener-

gy Laboratory’s (NREL’s) chart (Figure 7) were supported by the PV program and its predecessors.

The projects in the portfolio currently represent nearly \$200 million of investment (Figure 8), made over periods from 2 to 5 years. About half of the funding is national laboratory R&D through laboratory proposal development process agreements to NREL. This funding to NREL represents a sustained commitment to high-impact research and expertise across PV technologies, including thin films, silicon, III-V materials, performance testing, characterization, organic photovoltaics, and new material development.

The remaining funding in the PV portfolio is primarily awarded through our competitive funding opportunity

Figure 7: Record solar efficiencies of different technologies over the past several decades

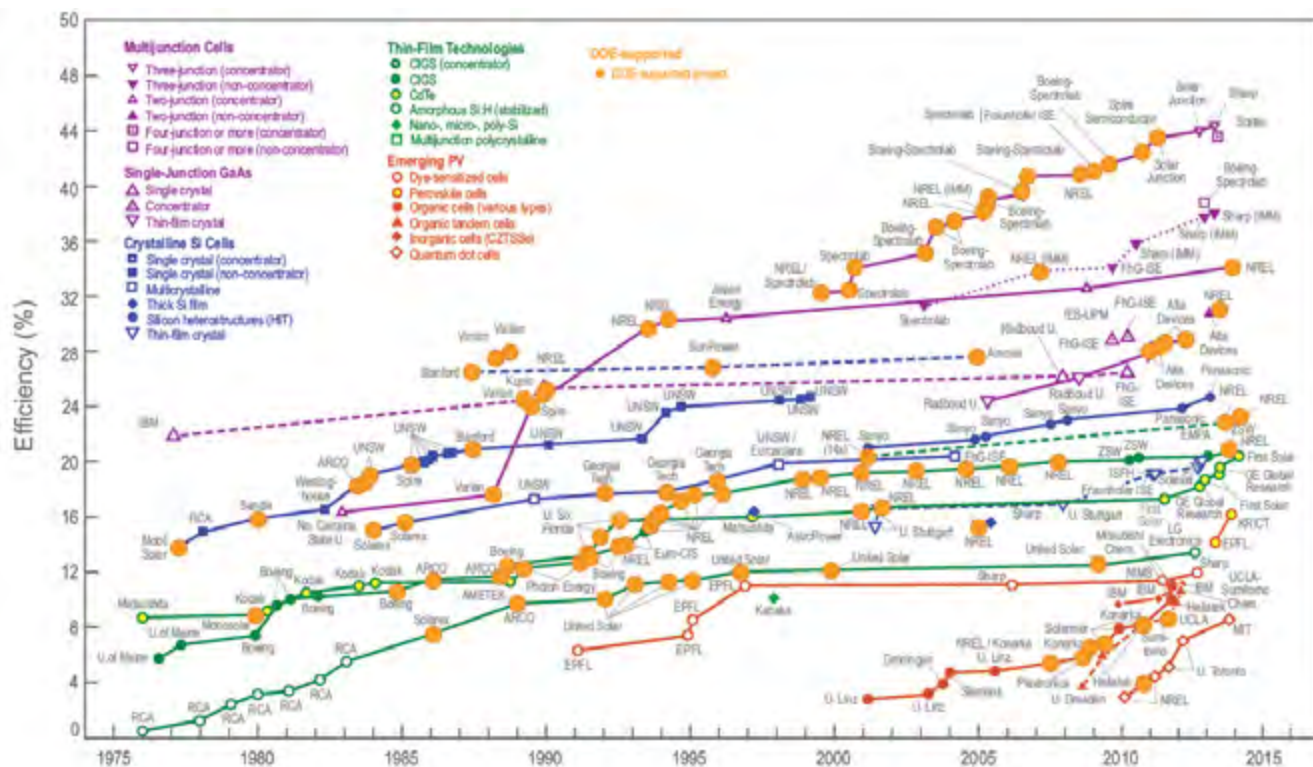

announcement (FOA) process to universities, national laboratories, and industry. We currently have 10 active funding programs. Next-Generation Photovoltaic Technologies (NextGen) 2 funds the development of early stage, transformational PV technologies. The Foundational Program to Advance Cell Efficiency (F-PACE) 1 funds, in partnership with National Science Foundation (NSF), significant advancements in existing solar cell technologies. F-PACE 2 focuses on the development of model systems to understand and overcome barriers to increasing efficiency in Si and thin film solar cells. The Bridging Research Interactions through collaborative Development Grants in Energy (BRIDGE) program supports collaborative research teams using DOE Office of Science research facilities to reduce the cost of solar electricity. We help to build a diverse and talented workforce of solar researchers through the Minority

University Research Associates (MURA) and Diversity in Science and Technology Advances National Clean Energy in Solar (DISTANCE) programs, which fund solar research at minority education institutions, and the SunShot Postdoctoral Research Awards, which fund recent Ph.D. graduates across the country. The Physics of Reliability: Evaluating Design Insights for Component Technologies in Solar (PREDICTS) program works to improve reliability by funding the development of physics-based models for PV degradation mechanisms. In addition, we have a partnership with NSF to fund the Quantum Energy and Sustainable Solar Technologies (QESST) center at Arizona State University and a partnership with DOE's Office of Science to fund Solar Energy Research for India and the United States (SERIUS).

Figure 8: Distribution of funding in the PV portfolio by recipient type, including both FOAs and national laboratory R&D

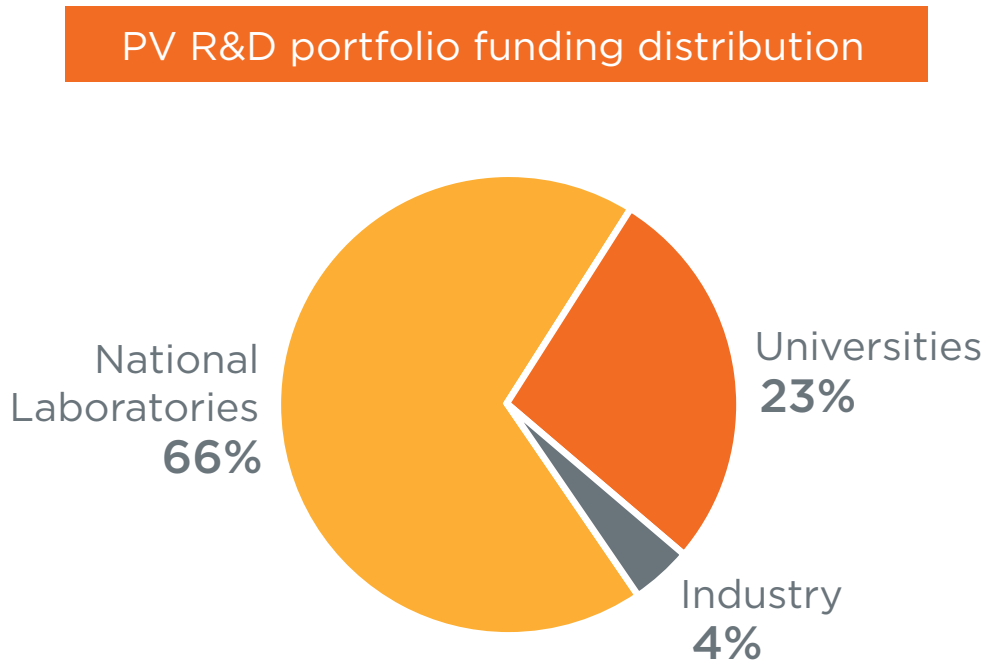

The activity areas of our portfolio are Next-Generation Photovoltaics, Training Next-Generation Researchers, Advancing Photovoltaic Efficiency, and Cross-Cutting Photovoltaic Efforts, each of which are detailed herein.



**Dr. Becca Jones-Albertus**  
*Photovoltaics Program Manager*  
 Solar Energy  
 Technologies Office  
 U.S. Department of Energy

**Team Members**

- Shubhra Bansal, SETA
- Susan Huang, SETA
- Marie Mapes, Technology Manager
- Lenny Tinker, Physical Scientist

**PV Portfolio Review Average, Range, and Standard Deviation**

Of the 251 projects in the SunShot Portfolio, 69 projects were reviewed as part of the Photovoltaics portfolio review. Each reviewed project is listed in Table 6. Projects were ranked on a 1–5 scale, with “1” being the lowest possible score for a category and “5” being the highest score. Reviewers provided overall ratings on each project’s relevance to the SunShot and PV portfolio mission and goals, overall impact, level of funding, and approach taken.

For the PV portfolio, the overall average rating for a project was 3.47. Of the 69 projects, 38 were performing above the mean, while 31 achieved scores that were lower than the 3.47 average. The range of overall scores was 2.58, with a median of 3.50, mode of 3.58, and standard deviation of 0.52, where each project’s score was an average of the individual reviewers’ scores. This information is presented in Table 5 and Figure 9. The reviewers’ comments on the program as a whole are provided in the following sections.

Table 5: PV Portfolio Review Average, Range, and Standard Deviation

	Average	Range	Standard Deviation
Relevance	3.69	2.00 – 5.00	0.65
Impact	3.22	1.67 – 4.33	0.60
Funding	3.52	1.67 – 4.67	0.67
Approach	3.43	1.67 – 4.67	0.71
Overall	3.47	1.84 – 4.42	0.52

Figure 9: Frequency of Overall Project Rating for PV Portfolio

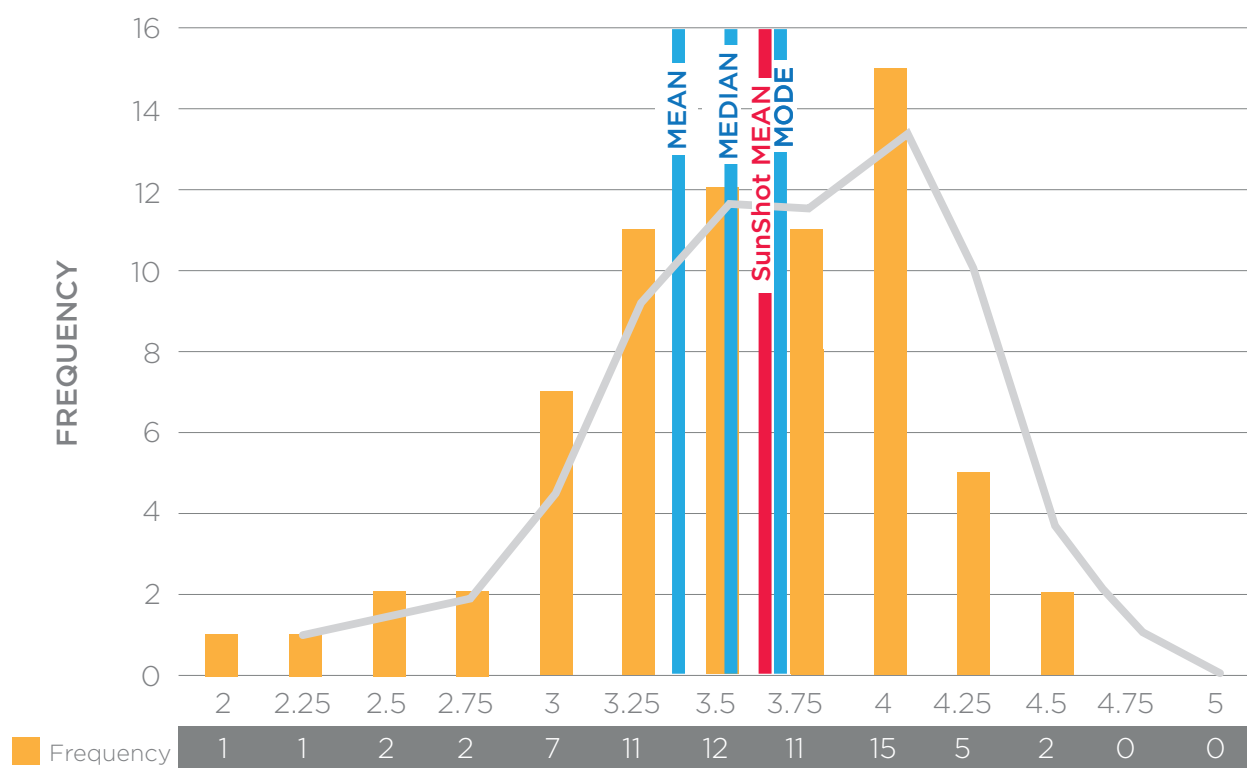

## PV Portfolio Reviewer Report

The following section contains the evaluation of the PV portfolio, as analyzed by the reviewers assigned to the PV Portfolio. To preserve the integrity of the reviewer's responses, the analysis is provided almost verbatim, with minor edits for grammar.

### Quality and Impact of the Portfolio

The overall portfolio is comprised of projects that are delivering results and are funded appropriately, such as

the work conducted by the Minority University Research Associates. However, there are a few underperforming projects that do not appear to add value to the Photovoltaics portfolio or SunShot Initiative as a whole. A strategy must be applied consistently across the portfolio to ensure success of projects.

The overall three-year management approach for projects does not work for all areas—DOE should consider different management approaches and tailor them for each specific area. Some projects may require a longer

timeframe to deliver meaningful results. At the same time, approximately 20%–30% of funds are directed to small programs, while a majority of funds are directed into traditional technology programs requiring that funding distribution to be reevaluated. In particular, the product output on the part of NREL was not commensurate with the high level of funding allocated to the laboratory. The PV portfolio budget is sliced too thin to enable big breakthroughs and required milestones at three month intervals also could present a problem in forging innovation.

To make the portfolio more impactful, there needs to be more industry involvement, collaboration between universities and other institutions, a modified approach copper indium gallium selenide solar cell (CIGS) development to avoid duplication of funding, and a greater focus on modules, encapsulants, metallization, hydrogenation in Silicon, and process tool development.

### Appropriateness of Funding Relative to Program Goals

Allocated funding is sliced too thin in this portfolio, and the portfolio is too broad. There is not enough funding on areas like energy production or packaging, but perhaps too much funding on absorber projects. For example, there is too much of the Photovoltaic portfolio funding directed to NREL, which is seemingly not being held to the same level of accountability as other projects in the portfolio. Better justification for allocating high

level funding to NREL is needed, and perhaps all funding should be allocated through the FOA process. There is also too much funding for *Solar Energy Research Institute for India and the United States (SERIIUS)*, which is a collaboration between the United States and India that has no apparent leadership, goals, or value to the program. Money allocated for that project would be better allocated elsewhere as the stakeholders of that project are not actually PV manufacturers in India.

### Future Direction and Composition of Portfolio

The future direction and composition of the portfolio must continue to examine new technologies, packaging, panel reliability, and industry involvement, as well as to develop analytic tools sets. Such efforts can enable future understanding and establish the foundation for breakthroughs. For PREDICTS projects, it is important to determine what the barriers are to making more reliable photovoltaic systems and determine that the focus needs to be on fundamental mechanisms. In terms of F-PACE, it is commendable that the projects focus on fundamental physics and that even more projects should focus on them. For BRIDGE projects, collaborations have been key to the success of that portfolio area and are helping those projects look to the future.

DOE might reconsider U.S. citizen rules for post-doctoral candidates as there is a need to involve the best and brightest people in R&D programs regardless of their country of origin.

Table 6: Projects Reviewed under Photovoltaics Program

Award Number	Project Name	Project Organization
2365	Quantum Energy and Sustainable Solar Technologies Engineering Research Center (QESST ERC)	Arizona State University and Partners
2366	Magnetically Guided Nano-Micro Shaping and Slicing of Silicon	Postdoctoral Fellowship
2367	New Nanostructured Materials for Efficient Photon Upconversion	Postdoctoral Fellowship
2368	Boosting Solar Voltage Output by Efficient Extraction of Auger Electrons	Postdoctoral Fellowship
2369	Stoichiometry, Interfaces, and Defects in Cu <sub>2</sub> S Photovoltaics: A Model System for Attaining Stability	Postdoctoral Fellowship
4002	Cost Effective Polymer Solar Cells Research And Education	Norfolk State University
4003	Production And Characterization Of Novel Photovoltaic Materials	North Carolina Central University

Table 6: Projects Reviewed under Photovoltaics Program

Award Number	Project Name	Project Organization
4004	Creating Green Talent in the Southwest: A Comprehensive Research and Education Program in Solar-Cell Technology at the University of New Mexico for Hispanic and Native-American Baccalaureate Students	University of New Mexico
5310	Transforming Organic Photovoltaics Into a Fully Practical Energy Solution	Regents of the University of Michigan
5312	Solution Processed PV Absorbers Based on Colloidal Nanocrystals Linked with Metal Chalcogenide Ligands	The University of Chicago
5314	Low Cost Back Contact Heterojunction Solar Cells on Thin C-Si Wafers: Integrating Laser and Thin Film Processing for Improved Manufacturability	University of Delaware
5315	Hole-Blocking Layers For Silicon/Organic Heterojunctions: a New Class of High-Efficiency Low-Cost PV	Trustees of Princeton University
5316	Single-Crystalline InGaAs/InP Dense Micro-Pillar Forest on Poly-Silicon Substrates for Low-Cost High-Efficiency Solar Cells	Regents of the University of California
5317	Reduced Cu(InGa)Se <sub>2</sub> Thickness In Solar Cells Using a Superstrate Configuration	University of Delaware
5318	Development Of Low-Cost, High Efficiency, Commercial Ready, Advanced Silicon Solar Cells	Georgia Institute of Technology
5319	New Materials For Implementing Tandem CIGS	Regents of the University of Minnesota
5321	Combinatorial Platform for Discovery of Nanocrystal-Ink Based Earth Abundant Element PV with Efficiency Greater than 20%	University of Washington
5322	Cvd-Based Valence-Mending Passivation For Crystalline-Si Solar Cells	Arizona State University
5324	Pyrite Iron Sulfide Solar Cells Made from Solution	University of California, Irvine
5325	Development of III-Sb Quantum Dot Systems for High Efficiency Intermediate Band Solar Cells	University of California, Los Angeles
5326	Hot Carrier Collection In Thin Film Silicon With Tailored Nanocrystalline/Amorphous Structure	Trustees of the Colorado School of Mines
5327	Beyond the Lambertian Limit—Novel Low-Symmetry Gratings for Ultimate Light Trapping Enhancement in Next-Generation Photovoltaics	University of Delaware
5329	Next Generation Sulfide Materials: Optimizing CZTS and Developing SnS by Systematic Defect Engineering	Massachusetts Institute of Technology
5331	Solar Upconversion With Metal-Enhanced Bimolecular Complexes	The Leland Stanford Junior University
5398	III-V/Active-Si Integration for Low-Cost High-Performance Concentrator Photovoltaics	The Ohio State University
5399	High Efficiency Commercial-Ready CdTe Solar Cells	Colorado State University
5400	High Throughput CIGS Solar Cell Fabrication via Ultra-Thin Absorber Layer with Optical Confinement and (Cd, CBD)-free Heterojunction Partner	Old Dominion University Research Foundation
5401	Development of High Electronic Quality CdTe Films Required For 1 Volt Open-Circuit Voltage CdTe Cell	University of South Florida
5402	Understanding the Effect of Na in Improving the Performance of CuInSe <sub>2</sub> Based Photovoltaics	University of Delaware
5403	Technology Enabling Ultra High Concentration Multi-Junction Cells	North Carolina State University

Table 6: Projects Reviewed under Photovoltaics Program

Award Number	Project Name	Project Organization
5405	Novel Contact Materials for Improved Performance CdTe Solar Cells	University of Illinois
5407	Advanced Precursor Reaction Processing for Cu(InGa)(SeS) <sub>2</sub> Solar Cells	University of Delaware
5948	In-situ X-ray Nanocharacterization of Defect Kinetics in Chalcogenide Solar Cells	Arizona State University
5951	In-Situ X-Ray Analysis of Rapid Thermal Processing for Thin-Film Solar Cells: Closing the Gap between Production and Laboratory Efficiency	SLAC- Leland Stanford Junior University
5953	Three-Dimensional Minority Carrier Lifetime Mapping of Thin Film Semiconductors for Solar Cell Applications	Plant PV, Inc.
5956	How Grain Boundaries Affect the Efficiency of Poly-CdTe Solar Cells: A Fundamental Atomic-scale Study of Grain Boundary Dislocation Cores Using CdTe bi-crystal Thin Films	University of Illinois
5957	Vapor Transport Deposition for III-V Photovoltaics	University of Oregon
5958	Collaborative Atomic-scale Design, Analysis, and Nanofabrication for Record Breaking, Single-crystal Zn <sub>x</sub> Cd <sub>1-x</sub> Te Solar Cell Arrays	University of Texas at El Paso
5959	Novel Photon Management for Thin-Film Photovoltaics	University of Utah
5960	In-situ Roll-to-Roll Printing of Highly Efficient Organic Solar Cells	SLAC National Accelerator Laboratory
6322	High Efficiency Thin Film Fe <sub>2</sub> SiS <sub>4</sub> and Fe <sub>2</sub> GeS <sub>4</sub> -based Cells Prepared from Low-Cost Solution Precursors	Delaware State University
6334	Driving CZTS to the SQ Limit: Solving the Open Circuit Voltage Problem	IBM
6335	Thin Silicon Solar Cells: A Path to 35% Shockley-Queisser Limits	Arizona State University
6336	Overcoming the Fundamental Bottlenecks to a New World-record Silicon Solar Cell	Georgia Institute of Technology
6343	Coupled Thermo-mechanical and Photo-chemical Degradation Mechanisms that Determine Reliability and Operational Lifetimes for CPV Technologies	Stanford University
6344	Unified Numerical Solver for Device Metastabilities in CdTe Thin-film PV	Arizona State University
24616	Improving V <sub>oc</sub> of CdTe Thin Film Solar Cells: Understanding and Taming the Grain Boundaries	Oak Ridge National Laboratory
24618	High Temperature, Roll-to-Roll CdTe Superstrate Devices Using Flexible Glass	National Renewable Energy Laboratory
24619	Accelerating CPV Efficiencies to Create a Sustainable Terrawatt Platform	National Renewable Energy Laboratory
24620	Enabling the CIGS Thin-Film PV Technology to Meet the DOE Goal of \$0.50/W Module Price	National Renewable Energy Laboratory
25774	Cell and Module Performance	National Renewable Energy Laboratory
25775	High Efficiency III-V Multi-junction Solar Cells	National Renewable Energy Laboratory
25776	Multifunctional Transparent Conducting Oxides	National Renewable Energy Laboratory
25777	Overcoming Spatial, Energy, and Temporal Limits in Characterization of the Electrical, Optical, and Structural Properties of PV Materials	National Renewable Energy Laboratory

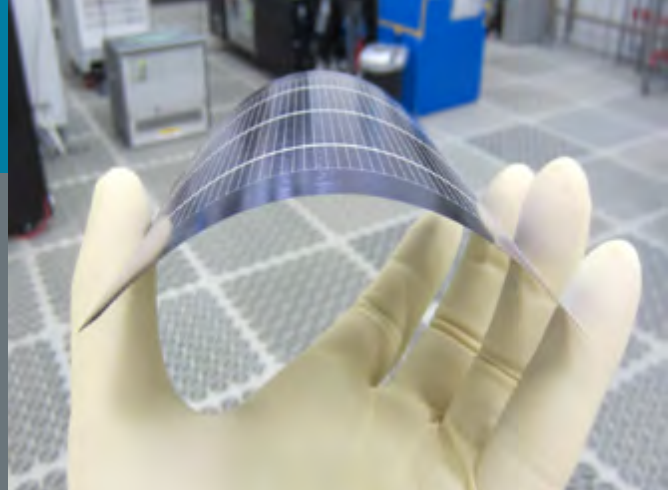

Table 6: Projects Reviewed under Photovoltaics Program

Award Number	Project Name	Project Organization
25778	CdTe Technology: Understanding How Defects in CdTe Limit the Performance of Solar Cells	National Renewable Energy Laboratory
25779	CIGS Thin Film Technology: Overcoming Barriers to Increase Efficiencies and Reduce Cost	National Renewable Energy Laboratory
25780	An Integrated Approach to Organic Photovoltaics	National Renewable Energy Laboratory
25781	Low-cost, High-efficiency, One-sun Hydride Vapor Phase Epitaxy III-V Solar Cells	National Renewable Energy Laboratory
25782	Next-Generation Earth-abundant Thin Film CZTS Photovoltaics	National Renewable Energy Laboratory
25783	Next-Generation Silicon Photovoltaics	National Renewable Energy Laboratory
25784	PV Partnering and Business Development Agreement	National Renewable Energy Laboratory
25785	Rapid Development of Earth-abundant Thin Film Solar Cells Using Inverse Design	National Renewable Energy Laboratory
25786	NCPV Director's Initiative and PV Capital Reserve	National Renewable Energy Laboratory
25853	Rational Design of Wide Bandgap Buffer Layers for High-Efficiency Thin-Film PV	Lawrence Livermore National Laboratory
25859	Developing Spectroscopic Photoemission Electron Microscopy for Imaging Nanoscale Variations in the Chemical and Electronic Structure of Thin Film Materials	Sandia National Laboratories
25860	Developing a Transparent Emitter Layer for CIGS Solar Cells through Synchrotron Investigations	National Renewable Energy Laboratory
26191	National Center for Photovoltaics Core R&D Support	National Renewable Energy Laboratory
27388	Approaching the Shockley-Queisser Limit with Epitaxial CdTe	National Renewable Energy Laboratory
28308	Solar Energy Research Institute for India and the United States (SERIIUS)	National Renewable Energy Laboratory

## PROJECT: 2365 ARIZONA STATE UNIVERSITY AND PARTNERS

*Quantum Energy and Sustainable Solar Technologies Engineering Research Center (QESST ERC)*



**FUNDING INFORMATION** \$6.0M | Crosscutting | 05/2011–05/2016

### Project Description

U.S. Department of Energy and the National Science Foundation's (NSF's) joint research center, QESST, is committed to research that spans the three leading commercial photovoltaic technologies: silicon, thin films, and tandem devices, while blurring the traditional lines between technologies by recognizing and exploiting their commonalities. This research is organized into three complementary thrusts—Terawatt Manufacturing, Moore's Law Devices, and Advanced Enablers—and two demonstrative testbeds—Student-Led Pilot Line and Integration, and Modules and Power Management. In addition, two themes—Sustainability and Education Research—permeate all areas of QESST research. QESST has 10 academic partners in the United States and around the world, along with 48 industrial partners that span the manufacturing, materials, production and installation of solar technologies.

### Individual Reviewer Comments

- The project has shown excellent outreach and partnerships.
- The project is very hard to review, given its two combined, yet unrelated efforts. In general, QESST research appears to be high-quality basic R&D, but it is diffuse. Additionally, it is not clear how this many institutions actually led to something worth funding, such as a center. The India activity has no information, and although it may have a legitimate political goal, there is no evidence that it supports the SunShot goal.
- The materials submitted appear to be incomplete. It is unclear what the focus of these various programs are or that they are making any progress.

## PROJECT: 2366 POSTDOCTORAL FELLOWSHIP

### *Magnetically Guided Nano-Micro Shaping and Slicing of Silicon*



**FUNDING INFORMATION** \$0.2M | SunShot Postdoctoral Research Awards | 10/2012–09/2014

### Project Description

This research effort has enabled the first successful direction-guided, nano/microshaping of silicon. The technique, utilizing a narrow array of Au/Fe/Au trilayer etch lines, is particularly effective in producing only micrometer-thick silicon sheets by rapid and inexpensive means with 20 microns ( $\mu\text{m}$ ) level slicing loss of silicon material, thus greatly reducing the waste of silicon material compared to the approximately 200  $\mu\text{m}$  kerf loss per slicing in the typical saw-cut silicon solar cell preparation. Such nano/microshaping may enable a whole new family of novel silicon geometries and exciting applications. Micrometer-thin, massively parallel silicon sheets, very tall silicon microneedles, zigzag-bent silicon nanowires, and tunnel drilling into silicon substrates have already been demonstrated.

### Individual Reviewer Comments

- The project addresses the primary photovoltaic (PV) technology and the major cost of cells. Although the cell cost is almost at its desired goal, the up and down in silicon markets can change it rapidly in the future, so this project is an important hedge against that. The goal of reducing silicon kerf loss during the mechanical dicing process is also likely to be achieved. The principal investigator (PI) and his advisor have strong capability and expertise in this area.
- The primary focus of the “Training Next Generation Researchers” program is to develop research talent that is required for the future challenges of solar research and development. It funds a postdoctoral student

working on novel methods of silicon wafer slicing—an area of investigation that is of great importance to silicon PV. The investigators are correct in that a large amount of silicon is lost in the manufacturing of silicon wafers. This is a practical problem, and novel techniques need to be brought to bear on this challenge. It is a good learning ground for new talent in the solar field!

- The magnetically guided chemical etching is a unique tool. The team made significant progress in this area, as evidenced by the previous publications and work that were presented in the poster.
- An important aspect of being a good researcher is to understand the problem you are trying to solve, have an awareness of the alternative pathways to a solution, and use this information to inform your research. Therefore, the researcher should visit a sawing operation to understand what would be important in an alternative pathway to a solution.
- The researcher is encouraged to investigate other activities in this space (e.g., kerf recycling) and develop a trade-off matrix. The technical merits of this program are less important to the successful training of a good researcher; however, there are clearly many practical limitations with the wafer sawing approach. For example, etch time for a standard-size wafer would be impractical; the cost structure would be uncompetitive due to the use of Ag/Au/Pt, chemical consumption, capital requirements, facilitization costs, and electricity for magnets and waste streams.

- The project focuses on the development of a new magnetically guided chemical etching method for etching silicon nanostructures, with the goal to reduce the silicon kerf loss from 200 micrometer to 20  $\mu\text{m}$ . The project is relevant, but it has no direct impact on silicon-based solar cell efficiency progress.
- Funding is relatively low for a two-year project.
- The work is mainly based on the published results from the previous record (all six journal publications that were cited are from 2004 to 2011). There is no clear indication as to when the new results/efforts were made during the funded project period and how this effort will be implemented with industry practice in silicon cutting. The speed of the etching method is also unclear. If the rate is significantly low, it is highly unlikely that industry will adopt this chemical etching method.
- The project has no chance of contributing to the solution and there appears to have been little thought regarding the needs and constraints (both time and costs) for such an industrial process. It is unlikely to yield anything of value.

## PROJECT: 2367 POSTDOCTORAL FELLOWSHIP

### *New Nanostructured Materials for Efficient Photon Upconversion*

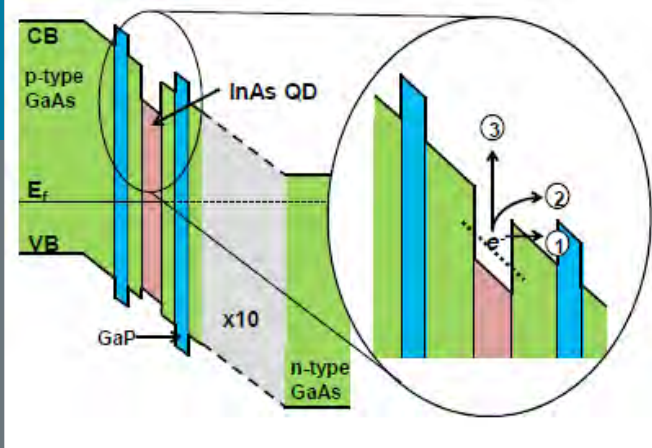

**FUNDING INFORMATION** \$0.2M | SunShot Postdoctoral Research Awards | 10/2012–09/2014

### Project Description

In this research effort, new designs are being developed for nanostructured materials that maximize upconversion efficiency and can be easily integrated with existing photovoltaic devices. The three objectives for this project are: (1) use well-controlled model systems to develop a fundamental understanding of the photophysical processes impacting upconversion efficiency, (2) develop new nanostructured devices with high upconversion efficiency and minimal energy sacrifice, and (3) develop implementations of this design that can be produced and processed at commercially relevant scales.

### Individual Reviewer Comments

- Upconversion is a potentially revolutionary approach to improving efficiency above the Shockley-Queisser (SQ) limit, but it relies on big breakthroughs in Upconversion Quantum Efficiency (UQE). It could have a tremendous impact on many different solar cell technologies. The project's focus on band engineering in nanoscale multilayer systems is promising for boosting UQE.
- The strengths of this project are the combination of modeling and experimental demonstration. Success is "to be able to measure something." The experimental plan seems to be logical and the approach to using multilayer particles is clever and very appropriate.
- The experimental plan seems to be sound, with both a model system and a system geared toward practical use as a bolt-on to existing single-junction cells. The approach may work if nonradiative recombination at the many interfaces, as well as geminate recombination, can be made negligible.
- The project is pursuing an opportunity that may be coupled with a range of PV technologies in a later stage; however, the potential benefits have to be considered very far forward looking. A combination of utilizing model systems and models (more needs to be done here), along with some practical demonstration is beneficial.
- The approach does not mention how it will deal with recombination at the interfaces, which, experimentally, will be a major problem.
- The downside of this project is that it needs a lot of individual breakthroughs to become a reality. It may need to become a larger project with more funding for the researchers to be able "to measure something."
- The approach's potential is difficult to evaluate; no UQE is reported for any of the structures because the project is in its early stages. Without a breakthrough UQE, this approach is not useful. The justification for using InAlBiAs as the funnel is unclear. Such a complicated graded layer will result in substantial non-radiative recombination.
- An efficient charge separation in indium phosphide (InP) and cadmium sulfide (CdS) quantum dots (QDs) is claimed, but the evidence for this on the poster is unclear.
- The project has a very challenging technical problem and a much larger effort would be required to produce any experimental success.
- The desire to produce a compatible mass production demonstration seems rather premature. Much more understanding is required on many core questions.

## PROJECT: 2368 POSTDOCTORAL FELLOWSHIP

### *Boosting Solar Voltage Output by Efficient Extraction of Auger Electrons*

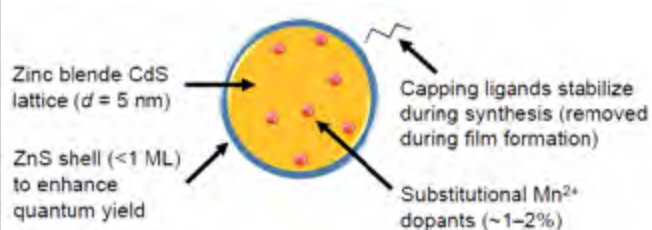

**FUNDING INFORMATION** \$0.2M | SunShot Postdoctoral Research Awards | 10/2012–09/2014

### Project Description

This project is a concept for increasing voltage in solar cell devices is proposed using non-radiative (Auger) de-excitation of metastable excited states of dopant ions. This hot carrier capture via interfacial electron transfer could be used to augment both photovoltaic and photoelectrochemical devices. The test case uses photoexcitation of cadmium selenide (CdS) nanocrystals, followed by efficient picosecond energy transfer to manganese (Mn<sup>2+</sup>), with a long-lived (ms) excited state lifetime. Electrons injected into the CdS then capture this energy via Auger de-excitation, generating hot electrons to be extracted at a higher potential.

### Individual Reviewer Comments

- This project looks at the fundamental processes involved in thermalizing the conduction band edges and finding a novel way of using those carriers to boost voltage. This project is important to understanding the fundamental options.
- While the project has not fabricated a solar cell so far (except for test devices that were designed to test the proof of concept), the result from the doped CdS QDs are impressive. It would appear that the energy transfer from the Mn<sup>2+</sup> ion to the band edge carrier is real and reasonably efficient in the test devices made so far; such an approach is promising.
- The relevance and impact are high, because if this approach works and is applicable to other material systems, it could redefine the concept of Auger recombination.
- The funding is appropriate for a postdoctoral fellow, but very small for the implications that this project could have.
- The approach could be revolutionary, transferring the energy to the manganese atom, and, in particular, to a spin up/down transition, which could change the way we look at thermalization.
- This project is seeking to significantly reduce one of the main thermodynamic losses within current semiconductor junction-based photovoltaic devices; namely, that of carrier thermalization, which arises when a carrier relaxes to the band edge after having been excited by a photon with energy far in excess of the bandgap energy. By doing so, significant efficiency enhancements are possible. Many schemes have been explored over the years with limited success because the material requirements and physical attributes of the absorber are stringent and difficult to achieve. However, if successful, this approach has revolutionary potential. Therefore, the relevance and impact are high.
- The ideal bandgaps for such a solar cell are somewhat different to the regime being investigated, so in the real world, device efficiency enhancement may be limited. However, the general physical principles may be transferable to other systems, resulting in better solar cells. Additionally, steps should be taken to ensure that the research continues to be useful, or used, after the completion of the project.

## PROJECT: 2369 POSTDOCTORAL FELLOWSHIP

### *Stoichiometry, Interfaces, and Defects in $\text{Cu}_2\text{S}$ Photovoltaics: A Model System for Attaining Stability*

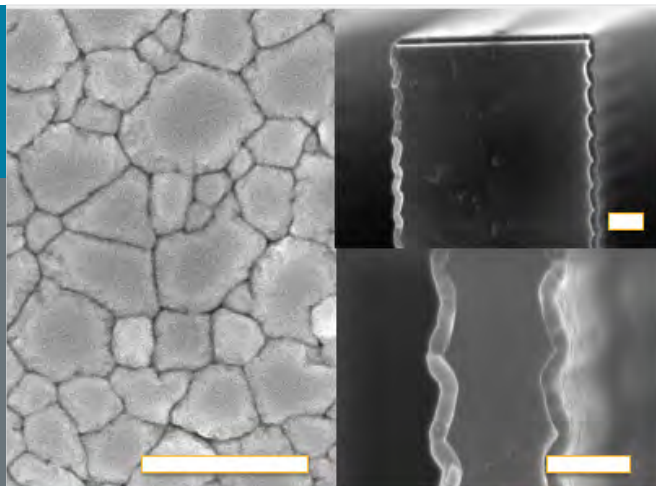

**FUNDING INFORMATION** \$0.2M | SunShot Postdoctoral Research Awards | 10/2012–09/2014

### Project Description

This research aims to synthesize copper sulfide ( $\text{Cu}_2\text{S}$ ) photovoltaic (PV) “model systems” by atomic layer deposition (ALD). Precisely defined ALD model systems will enable a fundamental understanding of the optoelectronic stability in  $\text{Cu}_2\text{S}$ -based devices. An in-depth look into the photophysical properties of such devices will further shed light on the importance of interfaces in thin-film PV devices. The potential impact of these studies will provide the grounds to understand why theoretical device efficiencies are rarely obtained in large-scale fabrication.

### Individual Reviewer Comments

- This project uses new tools to look into a material that was abandoned a while back:  $\text{Cu}_2\text{S}$ . Even if the project fails to solve the  $\text{Cu}_2\text{S}$  dilemma, the observations regarding Cu diffusion and device degradation are very current and applicable to other technologies. Basic Schottky and p-n junction device stacks have been made, demonstrating rectification, yet there is no photoresponse thus far.
- Thirty years of technological innovation may provide new means to addressing the issues that led to the abandoning of this technology. The project is quite comprehensive given the limited amount of funding it received. It has a good team that is well equipped to carry out the work.
- The team has shown significant accomplishments, including the growth of stable  $\text{Cu}_2\text{S}$  films by ALD, along with the discovery that one cycle of ALD alumina stops oxidation-induced Cu loss for at least one week.
- Understanding the effects of non-stoichiometry as it relates to interfaces and structural defects is fundamental to the engineering of earth-abundant devices.
- The approach needs to focus a bit more on the most pressing issues. The devices show no promise for this material, and even though the small carrier lifetimes may explain the lack of photoactivity, the energetics of the band alignments need to be revisited (especially since the  $\text{Cu}_2\text{S}$  that was achieved during this process is a high chalcocite and remains in the hexagonal phase). It would be interesting to see many of the degradation experiments done in comparison with grain growth-related parameters.
- Cu diffusion across the  $\text{Cu}_2\text{S}/\text{CdS}$  junction is the primary problem for this technology. It is unclear whether the approaches used in this project can address the Cu diffusion and degradation of this buried interface. ALD is a slow method that is probably unsuitable for a commercial technology. The question is whether the lessons/capabilities of ALD material translate into material that is made by a more practical technique. It is unclear how it is known that the starting films are stoichiometric  $\text{Cu}_2\text{S}$ .
- The very short carrier lifetime is not a good sign for ALD  $\text{Cu}_2\text{S}$ . Initial device results on ALD-grown structures are not encouraging. An exploration of alternative methods to form  $\text{Cu}_2\text{S}$  may be needed; however, funding may be insufficient to make significant progress.
- Greater clarity about the opportunity could be provided. Improving or demonstrating that the material can be stabilized only qualifies it to be considered for PV application and does not make it naturally a good choice.

## PROJECT: 4002 NORFOLK STATE UNIVERSITY

### *Cost Effective Polymer Solar Cells Research and Education*

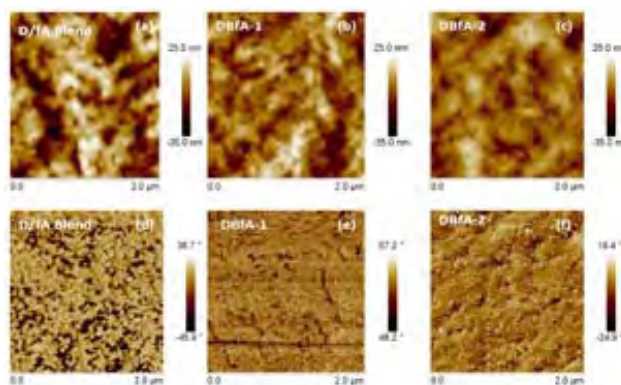

**FUNDING INFORMATION** \$0.3M | Minority University Research Associates | 09/2010–08/2014

### Project Description

The research objective is to investigate and develop polymer-based solar cells for potential cost-competitive, durable, lightweight, flexible, and high-efficiency solar energy conversion applications. A donor/acceptor bicontinuously ordered nanostructure-type solid-state morphology is targeted. The educational objectives of this project include training the next generation of young scholars, scientists, and/or technical workers to work on solar energy technology.

### Individual Reviewer Comments

- The project seems to be directed at developing nanoscale donor-acceptor networks of controlled morphology for Organic Photovoltaics (OPV). Improving domain size and spatial order is indeed a promising route to increasing OPV efficiency. The project has resulted in a great deal of basic characterization of the block copolymer active layer. Preliminary data that show 100 times higher efficiency for the self-assembled block copolymer relative to a blend of the same two polymers suggests that the approach is promising.
- The use of thermally annealed block copolymer film as opposed to an ordinary D/fa blend may hold some real benefit.
- Manipulating the chemical structure of polymers for improved exciton dissociation is one of many aspects that are needed to achieve high efficiency. In the absence of investigating all properties (recombination kinetics, heterojunction morphology, diffusion length, charge mobility, etc.) the probability of making a breakthrough is small. This is evidenced by the poor performance that has been reported to date. There is neither a clear concept for connecting structure to performance nor the governing factors that lead to better materials.
- The description of the project goals and approach is very general and unclear. The motivation for and potential advantages of using such block copolymers relative to other strategies is unclear. Additionally, the conclusions generated from some of the experimental results are somewhat speculative. The demonstrated efficiency results do not suggest a large impact on the field.
- Efficiency is low for OPV (0.22%), and the pathway to high efficiency is not convincing, especially with these large  $E_g$  materials.



## PROJECT: 4003 NORTH CAROLINA CENTRAL UNIVERSITY

### *Production and Characterization of Novel Photovoltaic Materials*

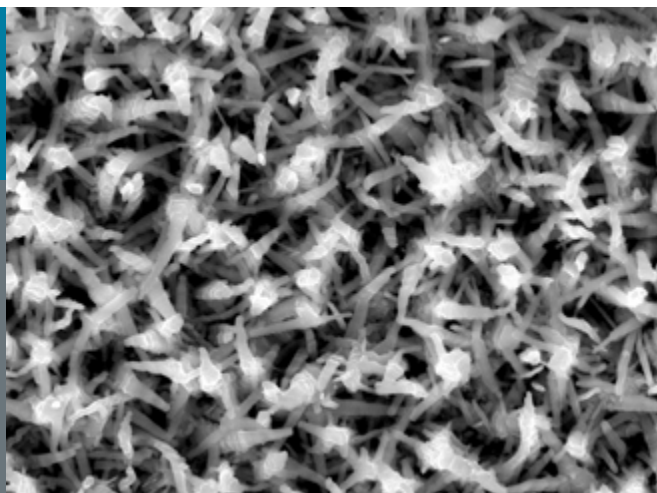

**FUNDING INFORMATION** \$0.3M | Minority University Research Associates | 09/2010–09/2014

### Project Description

This project enhances photovoltaic (PV) research and training efforts at North Carolina Central University that are focused on the development of novel nanoscale materials for PV applications. A unique ultrafast pulsed laser deposition and pulsed electron deposition facility is used to systematically study complex ternary and quaternary III-V, chalcopyrite semiconductor Quantum Dots (QDs), and nanowires that are anticipated to play an important role in the development of advanced PV cells. Theoretical modeling of the electronic structure and carrier dynamics of QDs and nanowires will complement the experimental research.

- The project is relevant to science, technology, engineering, and math (STEM) education.
- There are some interesting fundamental physics of the tunneling and growth of novel semiconductor nanostructures; however, it is doubtful that this project will have any substantive impact on future PV materials or devices.

### Individual Reviewer Comments

- The purpose of this project is to educate and train underrepresented (minority) students in this field. Given this goal, the students have been quite successful.
- The participation of two fully funded Ph.D. students and multiple high school students is impressive. This is cost effective for the scope of work.

## PROJECT: 4004 UNIVERSITY OF NEW MEXICO

*Creating Green Talent in the Southwest: A Comprehensive Research and Education Program in Solar-Cell Technology at the University of New Mexico for Hispanic and Native-American Baccalaureate Students*

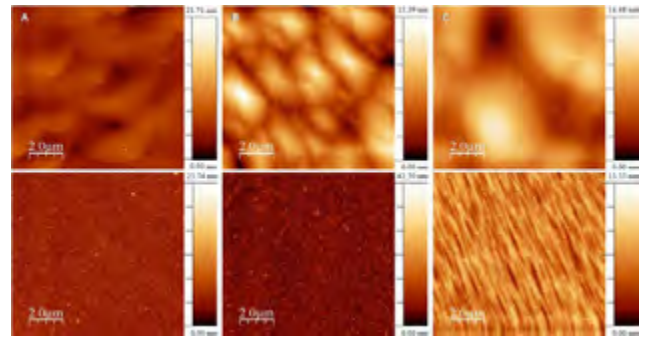

**FUNDING INFORMATION** \$0.3M | Minority University Research Associates | 09/2010–09/2014

### Project Description

This project establishes a third-generation PV laboratory at the Center for High Technology Materials where undergraduates will be exposed to research in nanotechnology-based PVs and ultra-high concentration solar cells, as well as a research effort in the Electrical and Computer Engineering (ECE) department on smart grids for future power distribution. Additionally, new core ECE courses are being developed for all undergraduates, which will introduce them to PVs from both a device and a power systems perspective.

### Individual Reviewer Comments

- The project is important for future generations.
- This is a modestly funded effort with many different goals. It is unclear if this project—which is focused on science, technology, engineering, and math (STEM) for Native Americans and Hispanics—is relevant to the PV industry or interested in R&D on Generation II materials. It is also unclear if the project is interested in Smart Grid or PV. The project is too diffuse and has no obvious impact.

- The synergy between third-generation PV, a pipeline for underrepresented groups in PV, and Smart Grid seems a bit tenuous.
- The smart grid effort appears to be unrelated to STEM goals and is not relevant for SunShot. It is also far behind the service-oriented architecture.

## PROJECT: 5310 REGENTS OF THE UNIVERSITY OF MICHIGAN

### *Transforming Organic Photovoltaics into a Fully Practical Energy Solution*

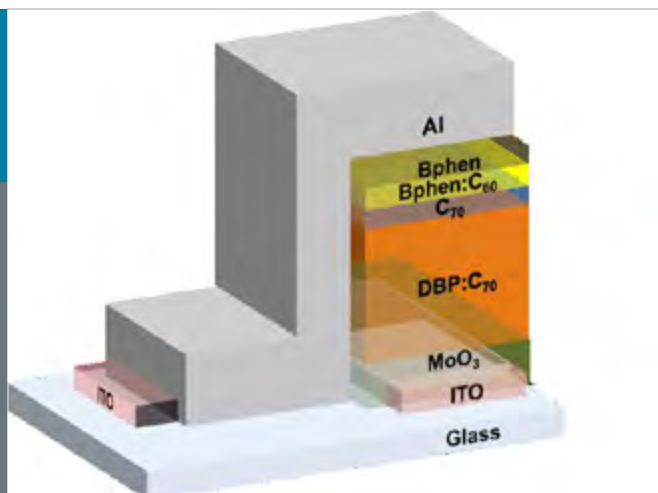

FUNDING INFORMATION \$1.5M | NextGen 2 | 09/2011–10/2015

### Project Description

This research effort addresses efficiency, reliability, cost, and scalability issues that must be resolved to transform organic photovoltaics (OPVs) into a competitively viable product. Small molecular-weight, organic nanocrystalline cells are stacked to form a high-efficiency tandem architecture. The research team is using low-cost, light in-coupling schemes to enhance efficiency; exploring liquid phase and organic vapor phase deposition; and subjecting prototype devices to reliability testing.

### Individual Reviewer Comments

- The project aims to make organic vapor phase deposition (OVPD)s competitive by achieving high efficiency and stability, and by moving toward scalability by using several “proprietary technologies” for small-molecule organics. The project has demonstrated some real progress toward the development, reliability, and manufacturability of multi-junction OPV devices. Its funding appears to be reasonable for the effort.
- The successes appear to be found in the development of the snow cleaning and organic vapor phase deposition (OVPD) processes, which shows it is possible to grow complete, active layers in approximately one minute at high uniformity.
- OPVs have the potential to attain scalable, low-cost PV devices. The caveat is that keeping the devices free of oxygen and water is essential to the long lifetime. This is as important of a component to the cost equation as efficiency and production costs.
- The target efficiency of 15% is less than the SunShot cost target, but if a sufficiently low cost is obtained, then the technology will make a contribution. However, balance of system costs are unlikely to be impacted by low efficiencies.
- The project offers a comprehensive approach (including modeling) based on the PI’s longstanding activities in OPV. There is also a demonstrated record efficiency quad-junction OPV of 12.6% efficiency. However, it is unknown if the 12.6% device is certified.
- Approximately 7% of single-junction devices demonstrated using snow cleaning and OVPD, which are techniques that may enable high-volume batch or roll-to-roll production. OVPD seems to be superior to vacuum thermal evaporation in most respects.
- Multi-junction approaches are required for higher efficiencies, requiring advanced cell interconnection development and different absorber materials. The approach here is correct. Recent efficiency advances from the maturity of stacked junctions show that the concept is working; however, the lifetime of these devices is still quite short. Understanding the degradation mechanisms and developing workarounds remain critical for the success of the project. It is not obvious from the reliability work that has been performed so far what the potential lifetime of this technology will be.
- Progress in improving stability is unclear. Encapsulated devices still show substantial degradation under operating conditions after just one week. The strategies being used to battle this (possible new buffer layers) are also unclear.
- The major thrusts of the project seem to be uncoupled. For example, reliability and scalability studies have not been done for the high-efficiency devices. It is not apparent why these have not been completed and what impact this is expected to have on the prospects of this project to produce high-efficiency OPV that lasts and is much cheaper to make.

## PROJECT: 5312 THE UNIVERSITY OF CHICAGO

### *Solution Processed PV Absorbers Based On Colloidal Nanocrystals Linked with Metal Chalcogenide Ligands*

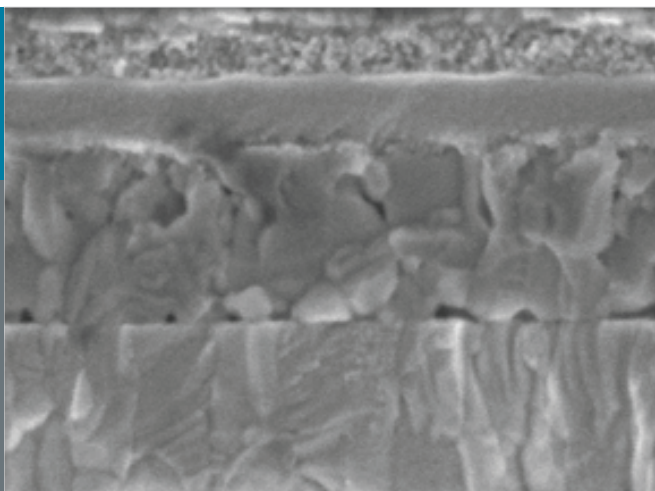

**FUNDING INFORMATION** \$1.5M | NextGen 2 | 09/2011–10/2015

### Project Description

The researchers of this project are developing solution-processed, all-inorganic photovoltaic (PV) absorber layers composed of colloidal nanocrystals. These are being electronically coupled through novel molecular metal chalcogenide ligands, which provide band-like carrier transport while preserving quantum confinement effects. At the end of the project, the research team plans to deliver a 20% efficient tandem cell composed of cadmium telluride (CdTe) nanocrystals for the top junction and lead sulfide (PbS) for the bottom junction.

### Individual Reviewer Comments

- The project focuses on developing tandem PV based on CdTe and PbS NC layers that are deposited from a solution and then sintered. The plan is to develop low-cost solution processable tandems that reach greater than 20% efficiency. This idea—which is similar to ongoing efforts in copper indium gallium selenide (CIGS) and copper zinc tin sulfide (CZTS)—is worth exploring.
- The project has a strong, appropriate team and there is good use of time-resolved spectroscopy at National Renewable Energy Laboratory.
- A major accomplishment is the discovery of new cadmium and lead chalcogenide anions for ligand exchange. Lifetime and diffusion length have been studied using time-resolved microwave conductivity, showing best values for sintered Na<sub>2</sub>Te-treated and sintered layers.
- A 12.3% sintered CdTe device with high short-circuit current density was demonstrated. A scanning electron microscope (SEM) image of a CdTe/PbS tandem was shown, but no performance data was presented.
- Solution-based PV is highly relevant to the Next Generation Photovoltaics program. The development of an all-solution-based, low T cell would be a breakthrough for the PV community. If successful, the proposed work could lead to nanocrystalline colloidal crystals for high-efficiency PVs. The budget is also reasonable for a six-person team.
- By combining PV devices using PbS and CdTe nanocrystal layers, the team designed and fabricated tandem cells with the top cell made of quantum-confined CdTe nanocrystals ( $E_g=1.6-1.7$  electron volts (eV)) and the bottom cell made of quantum confined PbS nanocrystals ( $E_g=1.0-1.1$  eV), thereby meeting the goals of DOE program.
- The project has shown some interesting progress to date; however, the Next Generation program should be more focused on the fundamentals that will enable high efficiency. Looking into the origins of these curious light-soaking phenomena seems fundamental to understanding the interfaces that result from these films, but it has been set aside. The analysis of the existing devices needs to be more thorough as there is a great deal of data that has already been collected in the effort to achieve the promised 24-25% efficient cells.

- The initial demonstration of the colloidal NC linked by metal chalcogenide ligands is new and unique and could lead to low-cost, high-efficiency PVs. However, the overall idea has a fundamental issue when the sintering of CdTe nanocrystals is implemented. How this sintering step could still maintain the nanocrystalline nature and characteristics in the cell is unclear. As evidenced by the SEM image in the poster of the CdTe layer, it has clearly been recrystallized to much larger grains with approximately 100 nanometers or more in diameter. It is unclear if this absorber layer still retains the original quantum efficiency as its nanocrystal form.
- The approach that entails the nanocrystals be dipped in cadmium chloride and sintered does not embody the overall objective of this project, which is to find a “solution-processed absorber.” In addition, the CdTe

device is sintered at 350°C, so the cell is no longer a QD cell but rather a small-grain polycrystalline cell without confinement. Charge transport is likely very similar to conventional CdTe. The fact that the sintered CdTe cell has a bulk CdTe bandgap (1.44 eV) presents two problems: First, the bandgaps are no longer optimal for a tandem. Second, relatively small-gap PbS nanocrystals must be used, and this relatively large amount of PbS has not made good solar cells thus far; therefore, it may be very difficult to produce decent tandem devices using this approach. It is unknown how unsintered devices with existing CdTe nanocrystals perform, along with what may be happening to the cells during the light soaking process.

## PROJECT: 5314 UNIVERSITY OF DELAWARE

*Low Cost Back Contact Heterojunction Solar Cells on Thin C-Si Wafers: Integrating Laser and Thin Film Processing for Improved Manufacturability*

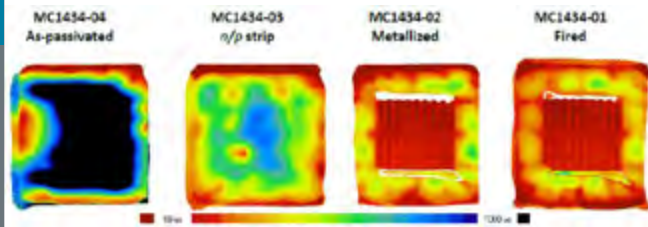

**FUNDING INFORMATION** \$3.8M | Foundational Program to Advance Cell Efficiency 1 | 09/2011–12/2014

### Project Description

This project aims to provide a pathway to \$0.50/Watt-peak (Wp) modules using thin, kerfless, back-contacted, heterojunction silicon solar cells (IBC-SHJ). The proposed IBC-SHJ approach offers advantages over other high-efficiency silicon cell architectures, including compatibility with thin silicon wafers (less than 50 micrometers [ $\mu\text{m}$ ]), by using low-temperature fabrication processes and a simplified laser-based manufacturing process that reduces the number of processing steps. By collaborating with IPG Photonics for laser processing and the Massachusetts Institute of Technology for defect impact minimization, this award aims to fabricate a greater than 20% efficient IBC-SHJ cell.

### Individual Reviewer Comments

- The primary focus of the “Advancing Photovoltaic Efficiency” program is to address technical barriers that are preventing the future advancement of cell performance. This project targets a credible pathway for achieving the objective of a \$0.50/Wp at 20% efficiency.
- Deposited wafers are a tantalizing potential cost saver and promise to deliver high-quality material at substantially lower costs. Including a cheaper approach to high-quality silicon—which is needed for achieving the \$0.50/Wp and the 20% efficiency goal—is a strength of this project.
- The inclusion of a strong industry partner, Crystal Solar, is a benefit to the program. It is noted that this report deals with the practicalities of epitaxial wafers at arm’s

length, and is more focused on cell processing. This is a missed opportunity, since much can be learned from a closer collaboration. This arm’s length practicalities were validated during the review session with the team and should be addressed to maximize learning.

- By far, the biggest weakness of this program is the lack of a stable heterojunction baseline from which to build the targeted process improvements. Industry leaders have demonstrated 25.6% efficiency and greater than 740 millivolts (mV) using IBC HJ on 100  $\mu\text{m}$  wafers. When comparing this to the best devices with 19% efficiency and an open-circuit voltage ( $V_{oc}$ ) of 665 mV, it can be immediately deduced that much effort will be spent on baseline development in this program. Gaps appear in the baseline integration; this weak baseline will hamper any major result during process simplification.
- It is positive that the project team is considering stability/reliability as a key area for investigation. The degradation of their passivation films in air after 100 days is clearly a key technical challenge. The team should dig a little into the mechanisms, as this will influence the development of a solution. An extension of this work that considers real-world field conditions would have strong benefits for everyone working on heterojunction with intrinsic thin-layer (HIT) structures. The performance of epitaxial silicon is limited by more than just light trapping, and what is limiting the performance has not been identified. The lifetime is reported as greater than 800  $\mu\text{m}$ , so it should not be limiting.
- Given the project objective of high efficiency on thin wafers, it will be worthwhile to run some “thinned”

wafers in order to enable a focus on the thin wafer problem rather than the epitaxial problems. The cell process flows being investigated may not provide the cost structures that are required to be competitive in a silicon solar marketplace five years from now. Many new 20-21% process flows are targeted to enter the marketplace. These will most likely be able to utilize the same epitaxial silicon wafer supply. It would be good to know what will differentiate this approach in the future.

- In the mainstream of cost-reduction opportunities, this is a significant evolutionary pathway for the University of Delaware's Institute of Energy Conversion, but it is missing a confirmed industrial partner (although Crystal Solar is referenced).
- The project has made progress on the front layer and laser contacting; whether this is an effective pathway will depend on whether the performance metric can

be further improved. The weak interaction with the commercial partner may be a concern in achieving higher efficiency.

- High-efficiency, low-cost silicon PV is the mainstream of corporate R&D. It must be understood that in order to provide significant contribution to the field, substantial investments and critical mass are necessary to stabilize a high-efficiency baseline (greater than 23%) from which new opportunities can be explored. This may require higher investment and a sustained effort. Given the significant effort in corporate R&D, active commercial partners would be desirable to strengthen the significance of the cost argument.

## PROJECT: 5315 TRUSTEES OF PRINCETON UNIVERSITY

### *Hole-Blocking Layers For Silicon/Organic Heterojunctions: a New Class of High-Efficiency Low-Cost PV*



**FUNDING INFORMATION** \$1.4M | NextGen 2 | 10/2011–10/2015

### Project Description

The aim of this project is to develop silicon/organic heterojunctions (SOH) and silicon/metal oxide heterojunctions (SMOH) as a new class of high-efficiency, low-cost photovoltaic (PV) technology. Instead of a conventional p-n junction, a silicon/organic heterojunction is used to separate carriers, and a silicon/metal oxide interface provides a hole-blocking layer. These devices are fabricated by spin-coating or spraying a thin layer of an organic semiconductor on silicon. This low-cost, room-temperature process eliminates the need for the high-temperature diffusion steps that are typically used to fabricate p-n junctions.

### Individual Reviewer Comments

- The primary focus of the Next Generation Photovoltaics program is to develop dramatically lower cost and/or improved efficiency to enable PV to achieve targets beyond SunShot. This program investigates the development of organic silicon solar cells to achieve this objective. The program promises a plausible pathway toward low-cost, high-performance solar cells. It is interesting, in this regard, to consider what cost elements this approach eliminates when compared to mainstream silicon solar cells. The silicon wafer cost and the need for metallization to carry the current are identical. The cost saving that is delivered by this approach is the junction formation and silicon passivation. These are not large cost elements within the process; hence, the large benefit of this overall approach must relate to the lower temperature processing, robustness of the process, and scalability (e.g., capital expenditures). The complexity added to the approach by the “hole blocker” continues

to degrade these potential gains (e.g., metalorganic vapour phase epitaxy [MOCVD]). More work is required to make this solution a compelling cost case versus baseline PV road map. This is a good university initiative that is potentially effective at reducing costs.

- The focus on developing a “hole-blocker” contact is a strength of the program. If this type of contact were successful, it could conceivably be considered an in for other silicon solar cell architectures—particularly those requiring low-temperature processing. The program should pivot to focus more heavily on these elements.
- The team’s focus on stability during the design phase of the program is excellent. This enabled them to include these dimensions in any of their design decisions. It would be worthwhile to take the testing to a broader set of screenings to include moisture, thermal, cycle, and other standard reliability tests.
- The project explores the novel idea of forming hole-blocking layers utilizing SOH or SMOH. Only one material prior to the present time has been explored due to its quick success. In strategizing whether the team should screen a range of materials versus optimizing one material, the prior is recommended over the latter. Such fundamental component demonstration could be useful and ultimately applied in either the perceived or alternative ways. Whether this idea has been deeply vetted as a true cost-reduction opportunity is not clear from the provided information. Additionally, it is only viable if the performance is matched to common approaches.



- The field reliability of an organic front passivation is questionable. In examining the limitations of the Si/organic architecture, work in this area should be a priority.
- The project is university based with a good educational impact. The materials that were presented focus on its status rather than the path that was taken to achieve it. Given the project's limited information and funding level, the results are not very rich.
- Considering that the project is in the middle of its third year, it is unfortunate that no devices have been fabricated to date. An alternative approach that would have utilized a highly effective n-blocker (e.g., a half of a HIT-like structure or any other high-efficiency baseline) would have been less "pure" toward low-temperature processing, yet it would be a faster and more reliable method for benchmarking the effectiveness of the hole blocker. At this point, relying on other metrics increases the risk associated with the success of the program. What if the determined band alignment is 0.1 eV in error? This is well within the experimental uncertainty of the program and could eliminate opportunity.

## PROJECT: 5316 REGENTS OF THE UNIVERSITY OF CALIFORNIA

*Single-Crystalline InGaAs/InP Dense Micro-Pillar Forest on Poly-Silicon Substrates for Low-Cost High-Efficiency Solar Cells*

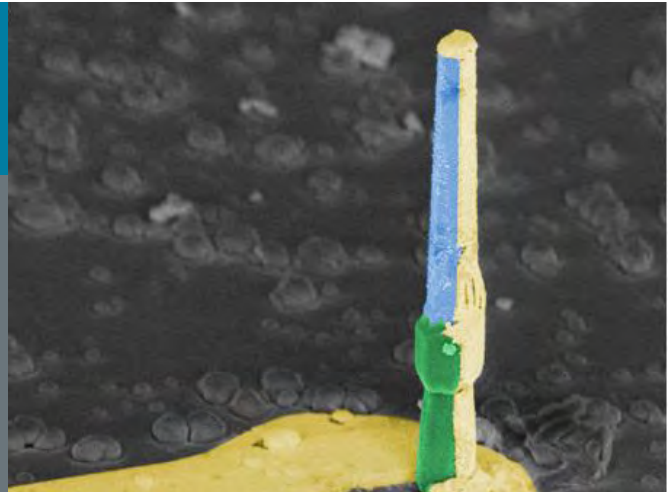

**FUNDING INFORMATION** \$1.5M | NextGen 2 | 09/2011–12/2015

### Project Description

The researchers of this project are developing a unique method to grow defect-free, III-V micro-pillar structures on single- and poly-crystalline silicon substrates. This approach combines the high-conversion efficiencies of compound semiconductor materials with the low costs and scalability of silicon-based materials. The dense forest of micron-sized indium gallium arsenide/indium phosphide (InGaAs/InP) pillars provides omnidirectional, broadband light trapping and reduces the amount of rare earth materials that are required.

### Individual Reviewer Comments

- The project focuses on decreasing the cost of III-V photovoltaic (PV), which is an important topic. The project has a good team that is using an integrated modeling/experimental approach. The team has created an impressive microscale device.
- The team has put forth some very interesting work on trying to get around III-V substrate costs, while using

SI and III-V nanostructured antennas. There has been some beneficial preliminary work on the behavior of such structures, leading one to believe that perhaps an efficient device could be achievable someday. The suggestion that the high short-circuit current density is due to a nanoantenna effect seems to be a bit premature.

- $V_{oc}$  is substantially less than the target value (of  $>0.7$  V in year 2 and  $>0.9$  V in year 3), perhaps due to doping limitations. It is important to know if these can be overcome. The existing contacting method shades half of the device with Ti/Au, and probably must be changed in order to make a good wire array PV. Major arraying and scale-up challenges still need to be tackled. Based on SEM data, the quality of wire arrays must be improved.
- The use of micropillar arrays is being widely explored by several laboratories. Here, the growth of III-V micropillars on Si substrates is advanced as a means for achieving low cost and high efficiency. However, the method of measuring and reporting efficiency seems to be inaccurate, since the area of the micropillar is not the area of the cell.

## PROJECT: 5317 UNIVERSITY OF DELAWARE

### *Reduced Cu(InGa)Se<sub>2</sub> Thickness In Solar Cells Using a Superstrate Configuration*

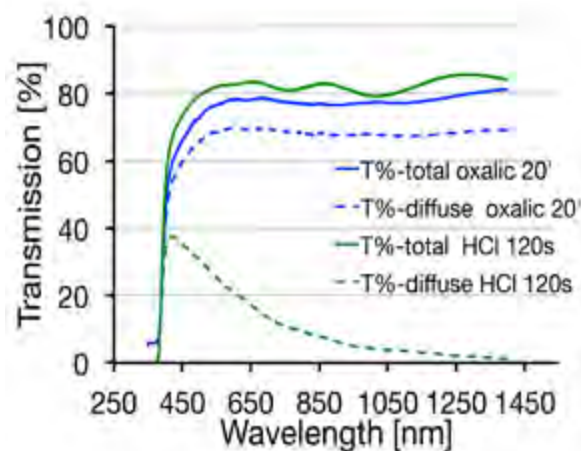

**FUNDING INFORMATION** \$1.1M | Foundational Program to Advance Cell Efficiency 1 | 09/2011–11/2014

## Project Description

To reduce the cost of Cu(InGa)Se<sub>2</sub> manufacturing, the research team is halving the thickness of the absorber layer. Project efforts include developing the technology and underlying science for using a superstrate cell configuration, which is essentially an upside-down version of the conventional Cu(InGa)Se<sub>2</sub> configuration. The anticipated outcome of the project is a copper indium gallium selenide (CIGS) solar cell with 0.7 micrometers thickness and 17% efficiency.

## Individual Reviewer Comments

- The project aims to reduce the materials costs, and, concurrently, improve the cell performance of CIGS. One of the project's strengths is its focus on fundamentally understanding the interface/materials interaction with the process parameters through careful characterization and theory. The understanding of the GaxOy formation by interdiffusion is an example of this.
- Overall, the cell has achieved better performance using the new cell designs. The team has been very productive, which is evidenced by six journal articles in 2013 and 2014. Additionally, the funding is considered reasonable for a four-person team.
- The development of an improved texturing for the transparent conductive oxide (TCO) process is of general interest and could be leveraged in other solar cell technologies. Across the board, light management is of critical importance to PV, and several technologies utilize TCOs. This new approach could provide a new building block for other device architectures in addition to CIGS.
- A weakness of the program is the low baseline performance of CIGS compared to leading institutions and industry. This capability gap will challenge the project's ability to validate any breakthrough results in performance and make the pathway to the targeted 17% significantly more challenging. One could consider looking for partners in the project to overcome this limitation and accelerate the learning curve.
- Combining a change in thickness with that of a new light-trapping scheme and new materials confound the analysis of the results for the device. The inclusion of new materials and new architectures indicate that the reliability of the device needs to be reconsidered. It is a weakness of this program that the device reliability is not considered to be a key feedback parameter—along with efficiency—in the research phase. The program team mentions the inclusion of several new materials to enable the thinner CIGS layers. Given that the thinner CIGS layers are driven by the desire to achieve a lower processing cost, the team should consider estimating the cost balance as new materials and process steps are added to the sequence. However, the project is not highly leveraging to cost reduction.
- Overall, this is a successful program. It would be beneficial to know the minimum thickness for this project design and to identify the path forward to achieve 20% efficiency.

## PROJECT: 5318 GEORGIA INSTITUTE OF TECHNOLOGY

*Development of Low-Cost, High Efficiency, Commercial Ready, Advanced Silicon Solar Cells*

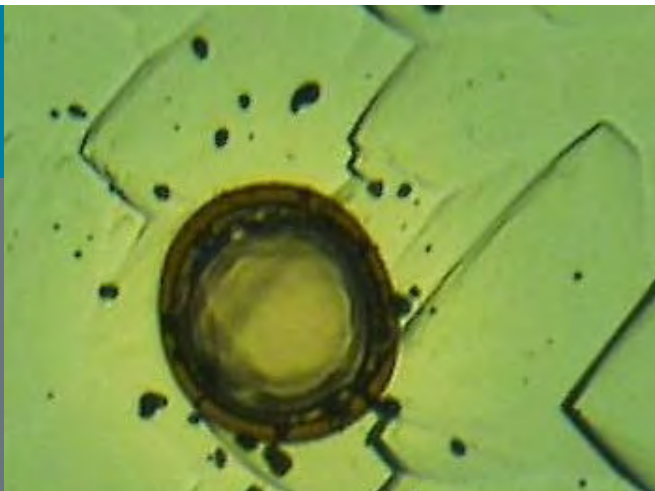

**FUNDING INFORMATION** \$1.5M | Foundational Program to Advance Cell Efficiency 1 | 09/2011–12/2014

### Project Description

The objective of this project is to raise the efficiency of three promising silicon technologies beyond 20%: conventional p-type crystalline silicon (Czochralski and monocrystalline), n-type CZ, and approximately 50 micrometers ( $\mu\text{m}$ )-thick-thick epitaxial silicon. Efficiency gains will happen through four technology innovations: (1) fine-line printing to reduce shadow losses; (2) reduced contact losses to increase fill factor; (3) improved surface passivation to lower surface recombination velocity; and (4) improved back surface reflectance. These innovations will be addressed with industrially-relevant technologies, reducing time between bench-top validation and factory implementation.

### Individual Reviewer Comments

- This program targets improving present-day industrial cell processes to enable lower cost and higher efficiency through the application of new wafers, cold-isostatic pressing of existing features, and introduction of passivated emitter and rear cell architecture. The partners that are participating in this program provide a good set of capabilities to enable delivery of the finer printing objective.
- The update indicates that the project team is working with an industrial partner on fine-line printing and ink manufacturing on refined pastes. It would be worthwhile to consider the capabilities of the project team to deliver the other objectives; for example, 50  $\mu\text{m}$  epitaxial wafers and industrially relevant process integration.

Similar partnerships to bring the correct capabilities to bear on these problems might be beneficial as well.

- The project tackles several critical efficiency limitation issues. If successful, a combined high solar cell efficiency can be achieved. The project focuses on the most widely applied Si-based solar cell systems; therefore, the industrial impacts are high. Additionally, funding is considered to be reasonable for a team of five to six people.
- The project scope touches on tabbing and interconnection as an area of investigation. This appears to be critical for the success of ultra-thin front contact cells. It is worthwhile to consider the capabilities that current players in the program can bring to this investigation. Without a viable module process, thin wafers will not be useful.
- Generally, the focus on incrementally advancing the performance of silicon solar cells is a worthwhile initiative; however, it is unlikely that an objective of 20% cell performance on high-quality CZ wafers will be sufficient given the marketplace competition. There are already many companies heading to pilot production with 21%–22% cell architectures using similar silicon and potentially similar (or simpler) cell processing complexity. An increased target efficiency would be required to ensure the commercial relevance of CZ results. The challenges of a stable boron emitter are critical to this approach.

- Some focus on further maturing this building block would be highly valuable. For example, the complexity represented by boron-rich layer removal needs to be addressed. Similarly, the program would benefit by considering the field reliability of these new architectures (e.g. Will the boron emitter suffer from light-induced degradation? What will be the impact of humid environments over time?). The results of the epitaxial wafer with a back surface field showed a back surface reflector of 80% compared to 95% for standard silicon solar cells. No explanation for the difference is provided, but given that epitaxial is a key pathway towards lower costs, it is a result worth repeating in order to uncover the root causes of the difference. This could result in some key developments that may enable higher performance for thin epitaxial cells.
- The role of Georgia Tech is not to function as a manufacturer, but to serve as a test bed for new cell ideas and to preserve the 30-year history of experience.
- The project's main weakness lies in the lack of uniqueness of its technical approaches. The four different approaches discussed in the summary are actually all the major approaches that the field has been focused on for a while. It is not clear how far this team can move beyond the current status of the research. The performance enhancement seems to be referenced by the team's previous record. It is not clear how this record compares with the state-of-the-art solar cell efficiency record.

**PROJECT: 5319 REGENTS OF THE UNIVERSITY OF MINNESOTA**

*New Materials for Implementing Tandem CIGS*

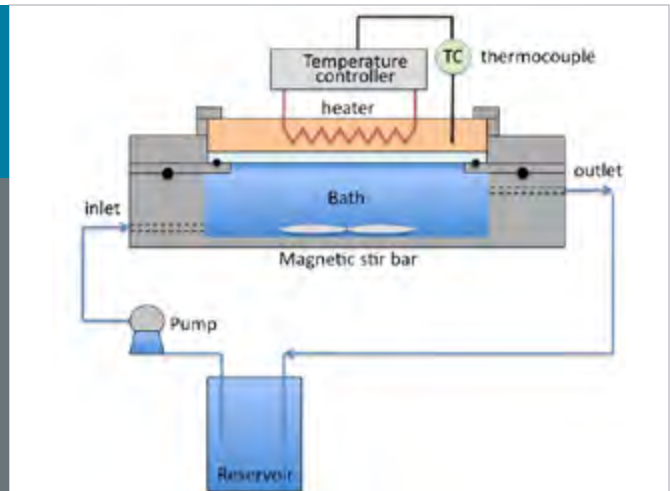

**FUNDING INFORMATION** \$1.5M | NextGen 2 | 09/2011–12/2015

**Project Description**

The researchers of this project are aiming to demonstrate the first functional copper indium aluminum gallium diselenide/ copper indium gallium diselenide (CIAGS/CIGS) tandem solar cell. The researchers are combining aluminum with both gallium and indium to form a wide bandgap absorber and developing a novel tunnel junction using thermal and air-stable oxides. Finally, they are introducing a graded  $CdxZn_{1-x}S$  layer using a novel continuous flow chemical bath deposition system which can better control process conditions and reduce particle loading.

**Individual Reviewer Comments**

- The project has a well-thought-out approach and worthwhile goal of trying to develop multi-junction CIGS. The team has made remarkable progress with good, broad insights. The impact on next-generation systems with high module costs could be significant.
- The team appears to be making real progress toward the realization of an efficient tandem based upon CIGS. They have demonstrated an effective wide bandgap CIGS device utilizing aluminum. They have also identified and produced a suitable material for a tunnel junction.

## PROJECT: 5321 UNIVERSITY OF WASHINGTON

*Combinatorial Platform for  
Discovery of Nanocrystal-Ink  
Based Earth Abundant Element  
PV with Efficiency Greater than  
20%*



**FUNDING INFORMATION** \$0.49M | NextGen 2 | 09/2011–12/2015

### Project Description

The University of Washington research team is employing solution-phase chemistry methods used for copper zinc tin sulfur selenium (CZTSSe) device fabrication to conduct high-throughput experiments with a novel combinatorial deposition platform. This approach allows for the discovery of alloying and doping strategies that produce a back surface field and defect passivation strategies that can dramatically decrease recombination and increase the minority carrier lifetime. By using photoluminescence, current-voltage, capacitance-voltage, and external quantum efficiency analysis, the researchers hope to rapidly converge on practical routes to high-efficiency CZTSSe-based solar cells.

### Individual Reviewer Comments

- This project addresses crucial basic challenges of CZTSSe composition, doping, and Voc control. It offers a combination of modeling, photoluminescence (PL), and electrical testing. Basic PL methodology is benchmarked and seems to work. Achieving a 10.5% efficient device by adding an alkali based on combinatorics results shows promise. The combinatorial approach for fast screening on defects and composition is considered to be innovative.
- It is a beautiful machine for CZTSSe combinatorics. This powerful model models PL response and extracts quasi-Fermi levels. This project addresses important points in the development of CZTS and is also in line with the goals of the Next Generation program.
- The project's main strengths lie in its unique combinatorial thin-film screening/synthesis approach as well as its exploration of fundamental efficiency mechanisms on the defects and composition tuning that uses a cost-effective, solution-based method with an ultrasonic spray coater.
- It has a great setup for combinatorial approaches and a strong correlation between PL characterization and electrical testing.
- The funding budget seems to be way too small for the goals and objectives of the project.
- It has a low-cost, high-throughput screening method for exploring the impact of its composition and defects on the overall cell performance. It presents a complete suite of synthesis, optical characterization, and solar cell testing. If successful, it could assist in the rapid design/testing of thin-film solar cells using CZSSe as the light absorbers. Similar concepts can be used for GaAs, CIGSe and other compounds.
- Over the past three years, the project has shown no sign of significant efficiency improvements. Its publication and patent record is relatively low.
- It is unclear how doping is corroborated and the structural and compositional characterization is performed.
- It is uncertain if this study is general enough to have a broader influence; e.g., how industry might adopt the findings and other thin-film processing methods. Additionally, it is not very clear what the targeted goal is for efficiency improvements.
- It is also unclear whether the combinatorial deposition method results in homogeneous material. What structural and phase characterization is performed? How is doping confirmed and distinguished from phase separation? Looking solely at PL is probably misleading.

## PROJECT: 5322 ARIZONA STATE UNIVERSITY

### *Cvd-Based Valence-Mending Passivation for Crystalline-Si Solar Cells*

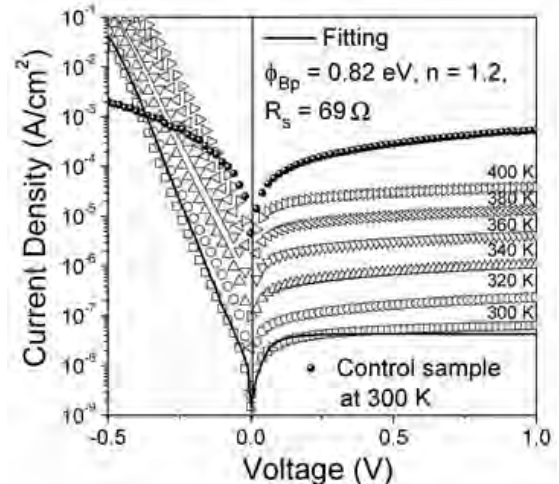

**FUNDING INFORMATION** \$1.5M | Foundational Program to Advance Cell Efficiency 1 | 09/2011–12/2014

## Project Description

This project combines innovative silicon surface passivation and all aluminum contacts to create a new processing path toward cost-effective, greater than 20% efficient crystalline silicon solar cells. The surface passivation enables lower contact resistance between the metal and silicon, allowing for less metal to be used. Cost would be further reduced by replacing silver with aluminum. Silver is the typical contact material in silicon solar cells and the second most expensive input material in the cell. Additionally, the surface passivation of grains in multi-crystalline silicon will be explored in the hopes of increasing the efficiency of cells that are made on this substrate.

## Individual Reviewer Comments

- This program focuses on a few new building blocks for silicon solar cells, aluminum/sulfur metal contacts, and aluminum plating. Overall, these are worthwhile objectives that further the leveled cost of energy performance of present day cells.
- The strength of the proposal lies in resolving the fundamental surface dangling bond issues that limit the silicon-based solar cell process and performance. The pathway outlined in this project is of interest to diffusion-based silicon solar cells, but it is less applicable to advanced heterojunction or passivated contact structures.
- With the valence-mending passivation method developed, the Principle Investigator (PI) and his team demonstrated record high and low Schottky barriers on silicon (100) surface for low-cost, high-efficiency crystalline-silicon solar cells.

- The PI and his team targeted a critical problem in crystalline silicon solar cells; e.g., surface passivation to resolve the surface dangling bonds issue on silicon surfaces. With such an approach, Schottky barrier height can be reduced for n-type silicon surface; therefore, aluminum contact can be used for silicon contacts. However, a smaller area of the contact is needed; consequently, efficiency can be increased.
- The relevance of electroplated aluminum to cost reduction, along with the role of Heraeus if plating is planned, is unclear. Additionally, for three years, funding is high for a two-PI project.
- The results so far are suggestive, but not demonstrative. At this point in the program, one might expect that a side-by-side cell performance would have been shown (e.g., baseline process with silver contacts versus a cell with aluminum/sulfur passivated contacts) and benefits would be evident given the fundamentally better contacts results that were measured. It would be worthwhile to separate this from the aluminum plating approach. The cost structure of aluminum processing needs to be included in the consideration of the statement, “Aluminum metallization is cheaper than Ag.” The associated auxiliary costs are non-trivial and could easily neutralize material cost savings. Given the partnership with Heraeus, it is unclear if it is possible to include the Al/S benefits into a printable aluminum paste. The shift from a silver grid to an aluminum metallization grid is non-trivial from a reliability point of view. Overlooking the reliability aspects of an aluminum metallization scheme is a major weakness of this project.
- After two and a half years, there are no major journal publications that resulted from this work, and the patent status is unknown. The cell performance results show very minimal improvement after introducing an S-terminated surface; thus, the benefit of such a process is not very clear.



## PROJECT: 5324 UNIVERSITY OF CALIFORNIA, IRVINE

### *Pyrite Iron Sulfide Solar Cells Made from Solution*

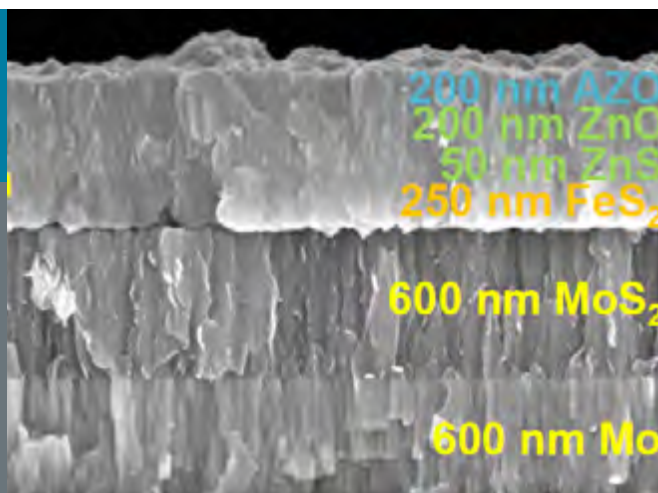

**FUNDING INFORMATION** \$1.2M | NextGen 2 | 09/2011–12/2015

### Project Description

The goal of this project is to build a prototype solar cell made from nontoxic, inexpensive, and earth-abundant iron pyrite (FeS<sub>2</sub>) (also known as Fool's Gold) with an efficiency of 10% or greater. The research team is developing a stable p-n heterojunction, using innovative solution-phase pyrite growth and defect passivation techniques. A pyrite-based device offers a pathway to meeting SunShot's cost targets, 20% module efficiency, and terawatt scalability using a proven, manufacturable geometry that is suitable for rapid scale-up by a U.S. thin-film photovoltaic (PV) industrial partner.

### Individual Reviewer Comments

- FeS<sub>2</sub> has been an eternal talent among prospective photovoltaic materials for decades. The idea of the present project is based on the authors' surprising discovery, which might shed a considerable amount of light on the problems of the past. The authors have figured out certain strategies on how to overcome these problems. Up until now, their assumptions have not been proven wrong, but rather, they have obtained important results.
- This project offers an earth-abundant material choice for low-cost thin-film PV. It displays a scientific breadth in its reporting, and its use of first principle calculations and model systems to accelerate learning is laudable.
- High-efficiency, earth-abundant materials for thin-film absorbers are highly relevant to the Next Generation program. Achieving conversion efficiencies of around 10% in pyrite will have an impact beyond the SunShot program. The project has a clear structure and is very ambitious, thereby fulfilling perfectly the requirements of a "next generation" materials project and clearly implying high-risk but also high-reward perspectives.
- The project funding is appropriate for the tasks that are delineated in the project, and the money appears to be very well spent. The project is dissected into three clear components: fundamental studies of electronic transport, surface passivation of pyrite, and the optimization of pyrite p-n heterojunction solar cells. The tasks that were proposed to tackle these issues follow a clean and logical path that builds upon the lessons learned from the previous step.
- Pyrite has been studied for many years. After hearing of its use, the first impression is typically, "oh god, pyrite again"; however, the project's publication record shows that this project team may have a new approach to bring to the table.
- The project's weakness is that this drop-in approach of replacing CIGS/CdTe with pyrite overlooks the appropriate optimization of the other layers of the stack. However, this is beyond what can be done in a four-year project. Additionally, it could be an interesting engineering problem should the efficiencies move closer to 10%.
- The project team should tackle the narrow-gap surface layer first.
- It is unclear why the project's focus is on solution-grown absorber materials. This may be inappropriate and limit performance at this stage of the project. Given that the material bandgap is sub-optimal, other material systems may be of higher interest. Establishing an alloy with desirable optical properties and film qualities should be an early step.

## PROJECT: 5325 UNIVERSITY OF CALIFORNIA, LOS ANGELES

### *Development of III-Sb Quantum Dot Systems for High Efficiency Intermediate Band Solar Cells*

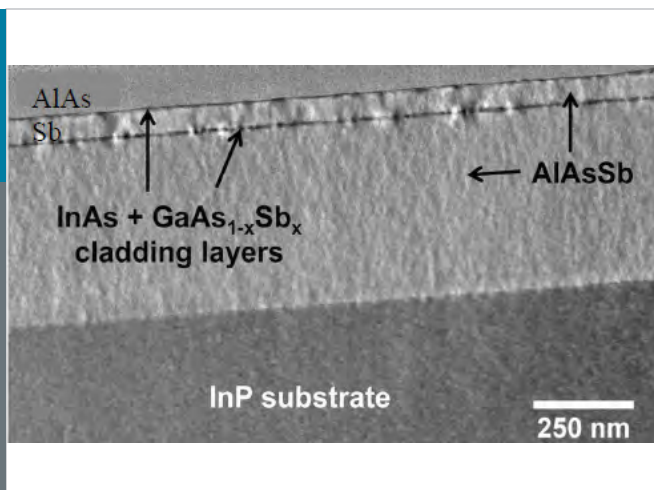

FUNDING INFORMATION \$0.9M | NextGen 2 | 09/2011–12/2015

### Project Description

The primary objective of this project is to identify and develop a III-Sb quantum dot (QD)-absorbing medium for intermediate band solar cells (IBSCs) via thorough experimental analysis that is supported by sophisticated band structure modeling. This is of interest because the theoretical efficiency limit of IBSCs is on par with triple-junction solar cells. The team is working on band structure calculations, QD solar cell device design, materials development, and in-depth experimental analysis of the QD superlattice properties using transmission electron microscopy, quantum efficiency, and two-photon absorption experiments. The team will be targeting the demonstration of a 20% IBSC with no open-circuit voltage loss.

### Individual Reviewer Comments

- The PI and her team members from the Rochester Institute of Technology and National Renewable Energy Laboratory are exploring the InAsSb QDs in AlAsSb p-i-n solar cells as IBSCs to increase solar cell efficiency. In the past three years, they have made progress in the processing, characterization, and solar cell testing of their samples. The additional strengths of this project include a set of innovative materials, control of materials fabrication, and photoactive intermediate band states.
- The team has also demonstrated 30% efficiency—though that measurement was not located in the poster. If successful, it could demonstrate high-efficiency QD-based solar cell structures.
- The project's relevance to SunShot's 2020 goals is moderate, because commercial QD photovoltaic (PV) is unlikely to play a significant PV market role within that time frame, and the United States does not have particular

advantages in QD-manufacturing technologies. The impact is moderate, as this is fundamental exploratory work. Funding at \$1.5 million per every 4 years is also moderate, yet reasonable.

- The QD approach is very unique and could potentially lead to high efficiency compared to other competition technologies. The approaches are reasonable, but progress has only been indicative of functionality—not advantage. For example, the proposed concepts work, but it is uncertain that they work better than previous concepts.
- The weaknesses of the project include a lack of significant device efficiency and broad-reaching technology know-how gains for QD PV.
- IBSC is relevant to the next generation of materials and devices. However, a fundamental problem that needs to be overcome before working on intermediate band cells is the fact that a new method needs to be developed to unequivocally be able to conclude that the observed transitions are indeed from the intermediate band. There is no real path for upscaling this technology. By using photoluminescence, it is unclear what the team is actually measuring (from what has been reported, the transitions that they think are from the valence band to the intermediate band can easily be intraband transitions in the conduction band). The concept of creating special contacts to extract the extra carriers is not even mentioned, which defeats the purpose of having an intermediate band material. Therefore, a tunnel layer should be considered.
- Molecular beam epitaxy growth of multilayer stacks of QD heterostructures could be very challenging and it is difficult to apply it to industrial processing; thus, the impact could be limited. It is neither obvious how to resolve the thickness limitation nor naturally bottleneck for high efficiency.

## PROJECT: 5326 TRUSTEES OF THE COLORADO SCHOOL OF MINES

### *Hot Carrier Collection in Thin Film Silicon with Tailored Nanocrystalline/Amorphous Structure*

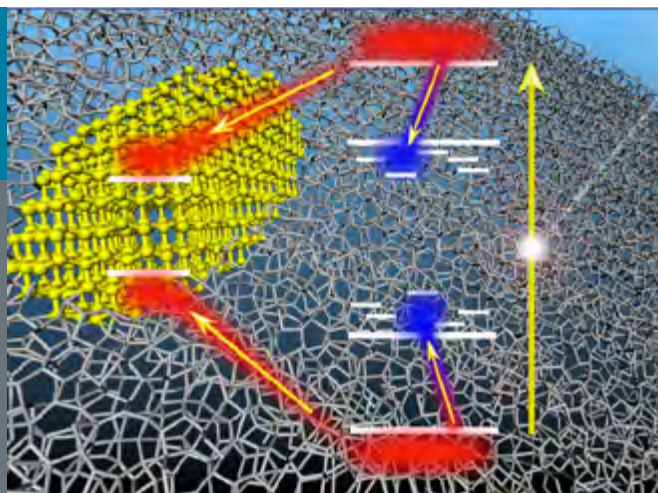

FUNDING INFORMATION \$1.4M | NextGen 2 | 09/2011–12/2015

### Project Description

The researchers of this project are developing a new approach to the synthesis of hydrogenated nanocrystalline silicon (nc-Si:H), which exploits hot carrier collection as a way of boosting conversion. By using a novel gas phase plasma process, the research team is creating engineered films that incorporate quantum-confined silicon nanocrystals with tailored surface termination. These engineered composites of amorphous and nanocrystalline silicon have the potential to dramatically increase the efficiency of single junction and multi-junction thin-film silicon solar cells by mitigating photo-induced degradation, increasing absorption, and offering the possibility of hot carrier devices.

### Individual Reviewer Comments

- Given the relative importance of c-Si heterojunctions with hydrogenated silicon, potentially applicable insights will emerge from this project.
- The strengths of this project lie in its multi-disciplinary approach to solving the problem at hand: the optimization and development of an all-silicon solar cell (perhaps multi-junction) that uses the combined novel quantum properties of nanoscale crystallites and amorphous silicon to produce a solar cell with strong absorption, minimized material use, and a high-operating voltage.
- There is much to accomplish in the time that is available. The elegance of the poster does not do justice to the sheer volume and scale of work that has been necessary to carry out this project. However, the project's relevance to the SunShot Initiative cannot be put into question. Such solar cells have the potential to deliver the low-cost, high-efficiency devices that SunShot requires. Unfortunately, there is still a long way to go; however, the Principle Investigator is optimistic that there will be progress in this area soon.
- The funding for this program is around \$350,000 per year, which, for a project with such a wide scope, seems surprisingly small (particularly where hardware development [here, a custom plasma-enhanced chemical vapor deposition tool with novel features decoupling the two main processes taking place] is concerned).
- The project approach is sensible, and the theoretical progress that has been made for the system is substantial, though only a little bit of the poster is devoted to results. There has been significant experimental effort so far; the data on the poster show good progress with materials characterization. However, the initial cell results of less than 1% efficiency are disappointing. It appears as though significant effort will be required in order to optimize the process parameters and device characteristics.
- The project is relevant to the Next Generation program, but its impact is really questionable, especially when thinking about the potential for scalability. The team takes the system idea from the University of Minnesota and plugs it into a plasma-enhanced chemical vapor deposition. The group is very interdisciplinary, and a great deal of significant work has been done, so it is hard to believe that with all of the National Renewable Energy Laboratory's know-how and expertise, they have achieved only 1% efficiency devices. It would be good to know why the team has not worked on surface defects and substrate quality before getting to this point. At this point, the milestone achievement of 12% efficiency seems unrealistic.

## PROJECT: 5327 UNIVERSITY OF DELAWARE

*Beyond the Lambertian Limit—  
Novel Low-Symmetry Gratings  
for Ultimate Light Trapping  
Enhancement in Next-Generation  
Photovoltaics*

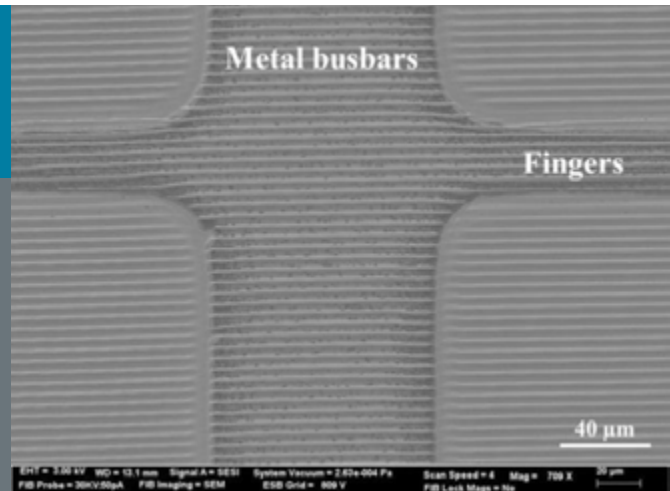

FUNDING INFORMATION \$1.2M | NextGen 2 | 09/2011–12/2015

### Project Description

This project is addressing the efficiency limit and high-fabrication cost of current light-trapping methods by developing novel low-symmetry gratings (LSG) for next-generation thin crystalline silicon (c-Si) and copper indium gallium selenide (CIGS) photovoltaic (PV) solar cells. The LSG design achieves light-trapping enhancement that exceeds the  $4n^2$  Lambertian limit within a specified range of photon wavelengths, and can be fabricated using a low-cost, single-step nano-imprint/molding technique.

### Individual Reviewer Comments

- This project seeks to enhance the absorption of solar cells which are optically thin—a requirement to meet the cost target of less than \$1/watt (through material reduction). In this manner, the project's relevance to the SunShot program is granted.
- The potential enhancement from these light-trapping schemes, even from the simulations carried out during this project, is relatively small, amounting to only a few percent. Every little bit helps when optimizing mature technologies, such as c-Si solar cells. Furthermore, the potential enhancement shown thus far is relevant, but it remains to be seen if such technologies can be implemented into the wider production environment of already mature products, while delivering a cost-benefit advantage.
- The program addresses a fundamental limitation for many areas of PV: light management in thin silicon solar cells. This is already critical for thin-film solar cells, and will become more critical for mainstream silicon solar cells as they use thinner wafers. The method presented could conceivably be scaled into mass production; however, the results up until now have been underwhelming. It would be useful to see more on this aspect of the project, because the results that were presented do not suggest that any enhancement was seen as a result of the addition of a grating.
- There are some useful dimensions worth considering, including reliability of these materials in real-world conditions, interactions with encapsulant materials, and an overall cost-benefit analysis compared to a “no film” case. Additionally, one may ask the question, what is the impact of these new materials and processes on the underlying cell reliability? It is worth considering real-world performance in determining the utility of this approach? For example, depending upon mounting configuration, the angular and specular content of the light that is absorbed into a solar panel changes throughout the day and throughout the year. How does this modify the optimal light-trapping solution? Furthermore, encapsulation into a module changes the optical system. These elements are worth considering in the initial modeling and design phase. This project appears to be

underperforming at generating interesting insights and useful enhancements to cell current through backside reflectance. It also lacks a cost analysis of an essentially small incremental efficiency enhancement. There is minor fundamental science happening here.

- The solar cell material in modern panels is often only a small fraction of the module cost (encapsulants, module boundaries, and manufacturing costs contribute significant fractions of the cost).
- Asymmetric gratings offer higher potential than the conventional state-of-the-art gratings, but after looking at normal incidence optimization, the approach in this project may be, perhaps, misjudged. Overall, there has been slow progress given the level of funding.
- The project uses nano imprint technology to demonstrate low-symmetry gratings to increase light coupling with c-Si PV. The concept is, in itself, incremental, yet very little has been done to successfully demonstrate the concept. Indeed, most of the results show a marginal improvement and understanding of best approaches. The PIs do not seem to have a full appreciation for the impacts and directions of their work. Given that we are quite advanced in the program cycle, more progress is expected.

## PROJECT: 5329 MASSACHUSETTS INSTITUTE OF TECHNOLOGY

*Next Generation Sulfide Materials: Optimizing CZTS and Developing SnS by Systematic Defect Engineering*

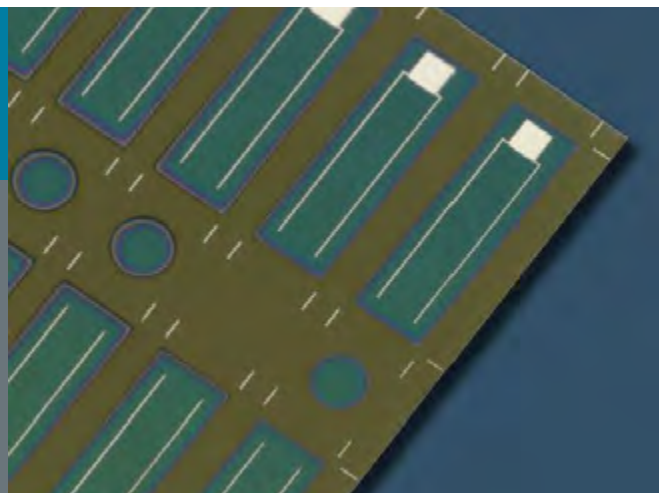

**FUNDING INFORMATION** \$1.5M | NextGen 2 | 09/2011–12/2015

### Project Description

The Massachusetts Institute of Technology is using systematic defect engineering to advance thin-film photovoltaic (PV) cells based on tin sulfide (SnS), which offers high optical absorption and high carrier mobilities. Because tin and sulfur are earth-abundant materials and require processing temperatures below 400°C, the use of these materials in thin-film PV cells has the potential to lead to low-cost fabrication. A rapid ramp-up of efficiency is also possible by leveraging the decades of developing similar thin-film materials.

### Individual Reviewer Comments

- The project's systematic approach is a strength. The objectives of the program are well structured to explore the basic elements that are required to make better solar cells. Good progress has been reported, and it is encouraging to see the buffer Zn(S,O) study deliver results that are consistent with expectations. In view of the project's progress, the funding seems to be appropriate and very well spent.
- The search for novel, nontoxic and earth-abundant photovoltaic absorber materials is a major subject of research for "next-generation" photovoltaic approaches all over the world. The choice of material in the present project is well motivated. Considerable progress in terms of achieved efficiencies has been demonstrated.
- Approaches are good, including a balance of theory, multi-faceted materials formation methods, and full-spectrum materials and device measurements and

analyses. The project's relevance to SunShot is moderate, as SnS cells are, at best, likely to become commercial far into future.

- The strategy of the project appears to be well structured, though it is not clear from the available material which bottlenecks the team will have to overcome in order to reach the final milestone. A detailed loss analysis of the present devices is necessary to identify those bottlenecks.
- SnS has a low bandgap; for a range of reasons, wider gap materials would be better suited for PV applications.
- The impact of the project is moderate, as the direct return on effort is likely low. There is, however, merit in a project participants' observation that careful systematic work in this field can be useful even in the absence of achieving full targeted results with this specific material.
- The weaknesses of the project include inherent materials science difficulties and low starting points for materials quality and device performance. It is a long road ahead. Additionally, disruptive progress in material quality will be required to achieve useful efficiency; it is completely unclear at this point whether this is achievable. The project team may run into a no-go situation, at which point efforts will end or need to be redirected. It is not clear from the project scope whether such a potential outcome has been considered in the layout of the project plan.

## PROJECT: 5331 THE LELAND STANFORD JUNIOR UNIVERSITY

### *Solar Upconversion with Metal-Enhanced Bimolecular Complexes*

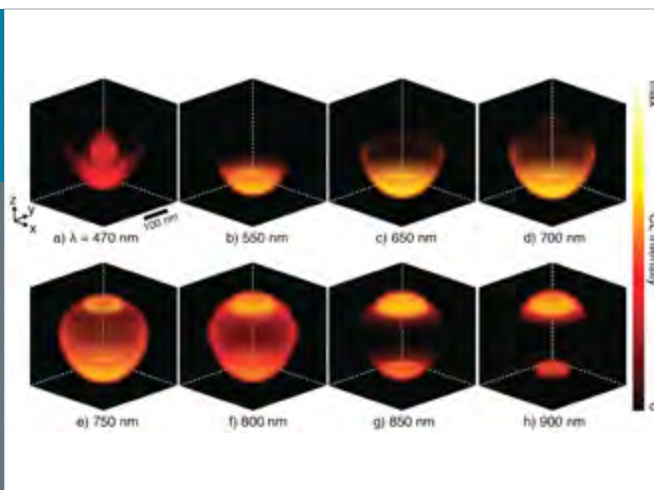

FUNDING INFORMATION \$1.3M | NextGen 2 | 09/2011–12/2015

### Project Description

This effort aims to develop an efficient medium capable of using plasmonic materials and processes to convert low-energy transmitted photons to higher-energy photons, which can then be absorbed by any type of commercial solar cell. The research team is using electrodynamic simulations and *ab initio* quantum computations to optimize existing upconversion processes and design new molecular complexes for high-efficiency photovoltaic (PV) upconversion in a solution-processable, scalable platform.

### Individual Reviewer Comments

- This project focuses on developing better upconversion materials by using biomolecular systems and lanthanide ions as two model systems. The goal is to make an upconverter that increases cell efficiency by 1% absolute (the current record is 0.014%).
- Overall, the project has a strong approach that combines modeling with fabrication. The fabrication strategy relies on using plasmonic nanocrescent antenna to enhance the absorption/emission of molecular upconverters.
- The project benefits from the involvement of industry partner, Bosch Solar. Its main achievements include devising electromagnetic models of upconverters and Bosch cells that show that approximately a 5% efficiency increase is possible with better quantum efficiency (upconverters; making plasmonic nanocrescents for increasing upconverter efficiency by an expected factor of 2; screening 25 biomolecular sensitizers to improve the absorption of sub-gap light; and using strain engineering to increase the radiative rate of lanthanide solids by 2 times.
- The project correctly seeks to study materials that have the potential to upconvert with an efficiency of at least 20%, with reasonable absorption bandwidth. Lanthanides and polymers make good candidates. The project has made great progress trying to put to the test the polymers in the solid phase. However, it is disappointing that the connection between the absorber and the emitter blueshifted the absorber.
- With regards to its impact, the success of the project would have implications for almost all PV technologies; it need not be only silicon cells that benefit from an upconversion boost. However, plasmonic particle manufacturing and integration with efficient upconverters still remains a project goal rather than an outcome. It would be difficult to manufacture it in volume at low cost at this stage.
- While the project makes no mention of any potential additional costs of its PV technologies, a 1% absolute increase in cell efficiency enabled through upconversion seems to be realistic, as 5% is difficult to achieve.
- The funding spans almost five years, which is realistic when attempting such fundamental materials research. The project's approach is well thought out, with a strong emphasis on fundamental materials understanding.
- To date, the results have been largely theoretical and speculative. Novel strategies, new plasmonic absorption enhancement, and novel 3D characterization techniques would be more appreciated if they yielded better physical demonstration of upconversion and PV efficiency enhancement.

- The project scope is very ambitious given the amount of funding. Combined, these strategies seem to promise only a factor of 4 or so improvement in upconverter efficiency, which seems to be insufficient to meet the 1% absolute goal.
- Biomolecular species seem to be more promising; however, no indication of improved quantum efficiency with covalent linkage strategy was demonstrated.
- The choice of upconverter materials may be insufficiently “outside the box” to achieving the necessary quantum efficiency improvements. The long-term stability of biomolecular upconverters is a concern. Additionally, an increase in lanthanide quantum efficiency is too small for practical use.



## PROJECT: 5398 THE OHIO STATE UNIVERSITY

### *III-V/Active-Si Integration for Low-Cost High-Performance Concentrator Photovoltaics*

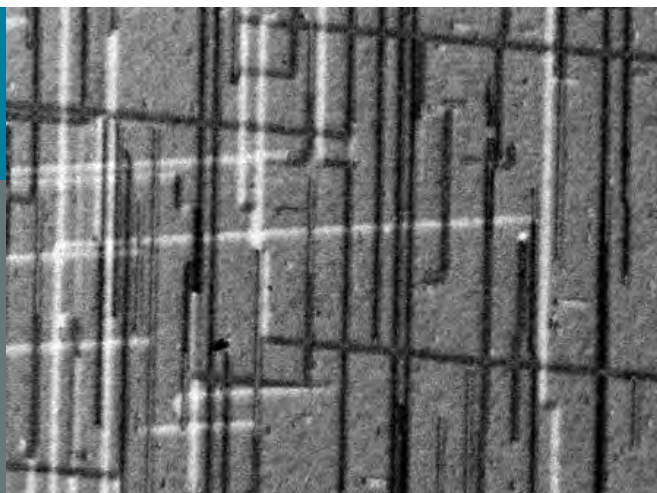

**FUNDING INFORMATION** \$1.2M | Foundational Program to Advance Cell Efficiency 1 | 09/2011–11/2014

### Project Description

This project works toward a paradigm shift for concentrated photovoltaic (CPV) technology, which is currently constrained by germanium (Ge) and gallium arsenide (GaAs) substrates in terms of cost and efficiency barriers. The project integrates GaAsP and Ga-rich GaInP-based subcells with a Si substrate to achieve high efficiencies with a roughly 100-time reduction in substrate cost per area. This yields a path to achieve panels at \$0.50/watt and provides access to the economies of scale afforded by a Si wafer-based manufacturing infrastructure.

### Individual Reviewer Comments

- This project shows a very strong materials science-based approach to integrating active Si and III-V cells in a multi-junction stack. The work is thorough, interesting, and has a good chance of achieving its important goals.
- The migration from expensive growth templates, such as GaAs, Ge, and indium phosphide (InP) for III-V multi-junction cells to silicon has been an obvious target within the community for some time. Of course, incorporating the silicon as an active junction makes further use of the material. Therefore, the project's relevance to the SunShot Initiative is high if the predicted efficiencies can be obtained.
- The development of electron channeling contrast imaging as a defect characterization tool not requiring transmission electron microscopy sample preparation and the associated cycle time is highly significant. This alone gives significant justification for the success of the project.
- A strength of this program is that it focuses on the development of III-V multi-junctions on silicon substrates. Presently, the cost of the substrates limits the application of this style of device to lower concentrations (e.g., larger substrates). The success of the project would provide a new pathway toward a larger range of system-level solutions and enable access to a larger available marketplace.
- The team is correctly focused on defect control and interface management. Their focus on test structures, modeling, and the use of approach characterization techniques is a strong approach to the resolution of this multiple trade-off problem. Moreover, their approach has been logical with various obstacles—such as tunnel junctions—being successfully overcome.
- The funding is commensurate with the project—even a little low, given the number of participants.
- So far the project has demonstrated relatively low efficiency numbers. It is not clear from the objectives what the ultimate goal might be other than to say that solar cells with appropriate bandgaps will be developed both above (III-V) and below (SiGe) the active silicon substrate.
- The impact will remain low unless efficiency can be addressed. In highly concentrated photovoltaic systems, such a technology is unlikely to become competitive—considering the properties of silicon (thermal voltage dependence and Auger recombination)—however, in low or medium CPV systems, a cell with more than 30% efficiency would be a significant improvement.

- Little, if anything, is said about the one potential stumbling block for monolithic integration of III-V with silicon: the significant mismatch of thermal expansion coefficients between the materials. Unless ultra-low temperature fabrication techniques can or have been developed, it is unclear how this project tackles this problem.
- Time to information is critical in the rapid resolution of these complex problems. The team was commended for developing new characterization techniques to speed up time to information. It would be worth asking the

questions, which other characterization techniques are bottlenecks, and could similar improvements be found? A weakness of the program is its focus on efficiency as the only measure of success. It fails to take into account real-world performance. It would be useful for the team to consider the sensitivity of their architectures to real-world spectral and thermal conditions in their optimizations. This is particularly relevant when they are considering triple-junction versus quad-junction cells.

- Overall, progress has been positive, but many challenges still lie ahead for this project.

## PROJECT: 5399 COLORADO STATE UNIVERSITY

### *High Efficiency Commercial-Ready CdTe Solar Cells*

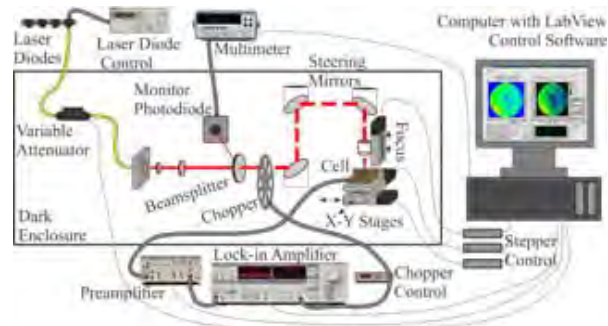

**FUNDING INFORMATION** \$1.5M | Foundational Program to Advance Cell Efficiency 1 | 09/2011–12/2014

### Project Description

The goal of this research is to improve the relative efficiency of cadmium telluride (CdTe) solar cells that are used in commercial modules by about 30% without increasing manufacturing costs. This is being accomplished by modifying the basic cell structure for higher voltage and fill factor, and incorporating plasma processes for final substrate cleaning and modification of the cadmium selenide (CdS) window for increased bandgap (higher current). Combined with modest decreases in production costs and anticipated advances elsewhere, this effort contributes to a reduction of the reported \$0.75/watt (W) module cost to the \$0.50/W target.

### Individual Reviewer Comments

- Fundamental work that could enable efficiency increases in industry settings is very relevant to the Foundational Program to Advance Cell Efficiency (FPACE). This project has two major components, which, if materialized and put together, could push CdTe performance beyond 18%. The relevance of the project is also high given the United States' position in CdTe photovoltaic (PV) manufacturing.
- The strengths of the project include a focus on impactful changes; e.g., higher  $V_{oc}$  with minority carrier preservation and higher photocurrents with a more transparent interfacial layer. The team is very productive at disseminating their research findings through journal publications and conference presentations. The project's impact, however, depends upon its long-term transferability to high-volume manufacturing (HVM) products (e.g., CdS:O stability, cost-effective HRT buffer between TCO and CdS:O, CdMgTe utility after Cl-based post-processing, etc.).
- The project aims to implement two changes to CdS/CdTe solar cells. These two changes are an electron reflector of CdMgTe (CMT) to increase voltage and a more transparent window layer to increase current. The team has made quite a substantial effort over the past three years; significant progress has been made with the electron reflector layer implementation, which increased cell efficiency from 13% to 19%.
- The project's two major efficiency improvements are the incorporation of an electron reflector of CdMgTe layer and a transparent window, which was achieved through oxygen deposition control (an increase oxygen pressure) during the growth of the CdS layer. These approaches are quite unique and effective, as evidenced by the efficiency enhancement. They are also promising, in that they are likely to be adaptable as HVM add-ons.
- The project offers unique approaches in efficiency improvement. This is a strong team effort because it focuses on two major approaches for efficiency enhancement and has made clear progress over the past three years in all three of its main tasks. Additionally, funding is seems to be appropriate, if not low.
- The third part of the project—the so-called “characterization” section—is a bit odd and out of place relative to the other two well-organized tasks. Clear progress has been shown thus far, but it is unclear what the final outcome will look like.
- The ultimate project goal is vague. For example, the goal might be to achieve ultimate solar efficiency and address the possible limiting factors in the last year of the program. Additionally, its weaknesses include uncertainties about the work's transferability to HVM.

**PROJECT: 5400 OLD DOMINION UNIVERSITY RESEARCH FOUNDATION**

*High Throughput CIGS Solar Cell Fabrication via Ultra-Thin Absorber Layer with Optical Confinement and (Cd, CBD)-free Heterojunction Partner*

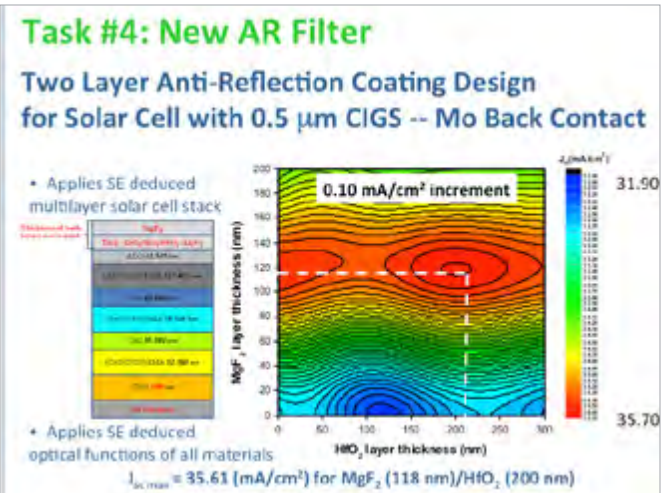

**FUNDING INFORMATION** \$1.1M | Foundational Program to Advance Cell Efficiency 1 | 09/2011–03/2015

## Project Description

Old Dominion University, in collaboration with The University of Toledo and the University of Illinois at Urbana-Champaign, is developing a high-throughput, high-efficiency copper indium gallium selenide (CIGS) solar cell fabrication process via the use of an ultra-thin absorber layer, optical confinement, and a heterojunction partner without cadmium (Cd) or the use of chemical bath deposition (CBD). These new designs and processes aim to reduce CIGS material costs by a factor of 10, multiply throughput production by at least a factor of 5, and achieve module costs of less than \$0.44/watt with efficiencies higher than 20%.

## Individual Reviewer Comments

- The project targets important areas of cost reduction for CIGS, including using much thinner absorber layers, reducing the time needed to make the devices, and improving the uniformity (which are not easy to do at the same time). The team has a strong approach of combining optical modeling with in-situ spectroscopic ellipsometry metrology of the film characteristics during processing. The team managed to make a 10.1% efficient cell with a 0.5 micrometer active layer. Proper attention was paid to light management in this thin CIGS stack (with back contact design and front anti-reflective [AR] filter).
- The cell with an atomic layer deposition (ALD) zinc sulfide (ZnS) window shows promising performance. The team has also produced a large number of presentations and publications. Additionally, the group has made progress on a number of fronts (e.g., back contact reflector, reduced absorber thickness, CBD elimination, and anti-reflective filtering).

- The project focuses on the reduction of absorber thickness in CIGS solar modules, primarily to reduce the usage of rare indium. To achieve this task, a series of measures are necessary, such as enhancing the reflectivity of the back contact, growing thinner absorbers with the same material quality as the usual ones, and developing non-CdS buffer layers to improve the blue response of the devices. This list corresponds to project Tasks 1 through 3. Task 4, the development of AR filters on the non-encapsulated cells, is a subject of minor relevance.
- Up to the present stage, some promising results have been achieved in the direction of the final project goal. However, a clear strategy regarding how to overcome the identified difficulties that arise from thinning the CIGS absorber material—especially how to achieve efficiencies of greater than 16% and how to maintain industrial process stability in view of the more critical process—is missing.
- Most of these ideas have already been explored in the past, so it would be helpful to know what is new this time around. Additionally, none of the developments have demonstrated obvious promise that would justify their inclusion in commercial systems.
- Project data show that device efficiency steadily falls with decreasing CIGS thickness (from 16% at 2  $\mu\text{m}$  to 8% at 250 nm), so it is unclear whether high-efficiency extremely thin absorber cells are possible or practical. It was difficult to determine what progress has been made on several project goals, including enhancing uniformity and cell throughput.
- Substituting one slow process for another (ALD for CBD) has questionable throughput advantages. The use of ZnS rather than CdS is not itself new.

## PROJECT: 5401 UNIVERSITY OF SOUTH FLORIDA

*Development of High Electronic Quality CdTe Films Required For 1 Volt Open-Circuit Voltage CdTe Cell*

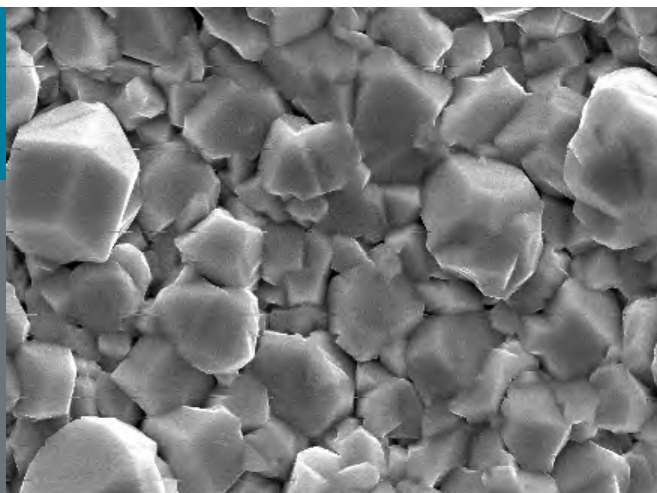

**FUNDING INFORMATION** \$0.99M | Foundational Program to Advance Cell Efficiency 1 | 09/2011–01/2015

### Project Description

Thin-film cadmium telluride (CdTe) is today's lowest cost photovoltaic technology, but the open-circuit voltage of these solar cells has stayed at 0.85 volt (V) for nearly 20 years. In order to reach the practical potential of thin-film CdTe cells, the open-circuit voltage of the cell must increase to about 1 V. The main goal of this project is to demonstrate that CdTe films with doping concentrations greater than  $10^{16} \text{ cm}^{-3}$  and lifetimes in the range of 1–10 nanoseconds (ns) can be prepared, which is consistent with a  $V_{oc}$  of 1 V. Increasing the  $V_{oc}$  to this level paves the way toward reaching 20% cell and 17% module efficiencies.

### Individual Reviewer Comments

- The Project seeks to increase the Voc of CdTe above 1 V by increasing the carrier density above  $10^{16}$  and the lifetime above 2 ns using doping by copper (Cu) or chlorine (Cl). A better understanding of doping and defect control is important for increasing the efficiency of CdTe devices. Achievements include using the Cd/Te ratio to tune the carrier type and conductivity.
- Raising the open-circuit voltage of CdTe closer to its theoretical potential is extremely relevant to the SunShot goals and will go a very long way toward helping achieve \$1/watt. A better fundamental understanding of the roles of Cu and Cl is required for CdTe cells to reach their full potential.
- Funding appears to be reasonable for a three-year program at \$400,000 per year. It is assumed that the overheads on sample production are relatively high, and that a large number of samples are being produced. In addition, the approach is highly experimental in nature. Perhaps it would benefit from a more theoretical overview; at the moment, most of the results are being compared to (unreferenced) models in the literature.
- This project also addresses its relevance to SunShot program goals by looking closely at a specific deposition process (elemental vapor transport [EVT]) for the fabrication of CdTe thin films. It is clear to the reviewer that such an approach will not yield devices approaching 20% at a cost level that is required. The potential impact, if successful, is significant, with approximately a 10% increase in the predicted Voc (assuming that there is no loss of short-circuit current density or fill factor). However, the kind of experimental “parameter space survey” is the incorrect approach. CdTe crystals, grain boundaries, and extrinsic dopant incorporation would benefit strongly from a theoretical modelling approach and a more systematic approach to dopant solubility and incorporation (e.g., in understanding the 3 order-of-magnitude difference between active and inactive antimony [Sb] incorporation).
- It is uncertain how changing Cd/Te ratios represents progress toward the 1 V Voc goal. No indication was given that the methods have yielded improvements in lifetime or desired changes in carrier density.
- Unfortunately, the results thus far seem quite inconclusive. It is not exactly clear what is causing the variation and the lack of clearly defined trends with Cd/Te ratios or dopant concentrations. It was not made explicit if this is an artifact of the EVT process, and exactly how the EVT process that is being used differs from the conventional close-spaced sublimation system. The other possibility is that there are too many variables being altered at once to see any predictable behavior. It appears as though the project could use additional fundamental characterization or theoretical support to help guide its experimental work.

## PROJECT: 5402 UNIVERSITY OF DELAWARE

### *Understanding the Effect of Na in Improving the Performance of $\text{CuInGaSe}_2$ Based Photovoltaics*

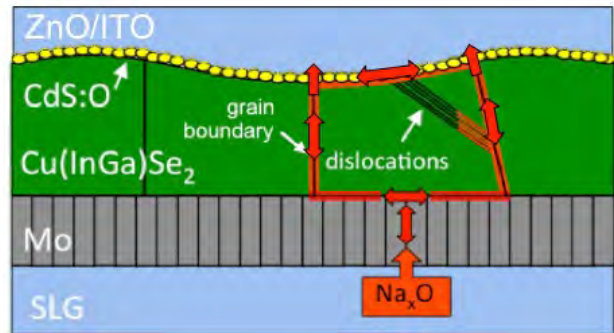

**FUNDING INFORMATION** \$0.96M | Foundational Program to Advance Cell Efficiency 1 | 09/2011–11/2014

## Project Description

The University of Delaware, together with the University of Illinois at Urbana-Champaign, strive to find the pathways through which sodium (Na) improves the performance of copper indium gallium selenide (CIGS)-based PV devices. The researchers are growing CIGS films with different amounts of Na for full characterization. They are also fabricating devices to highlight correlations of operation, Na dosage, and the method of incorporation. This investigation helps provide a basic scientific and engineering understanding of the role of Na in CIGS photovoltaics (PV) that is needed for advancement toward the \$0.50/watt module manufacturing goal.

## Individual Reviewer Comments

- Such a fundamental mechanism study is important and could lead to better PV designs by implementing the sodium dopings. The project's strengths include a variety of experiments and materials.
- The origin and effects of sodium in CIGS absorbers need to be understood in order to find optimal processing conditions and substrates and/or buffer layers that can boost performance. This can also shed light on the character of the grain boundaries, which, ultimately, seem to be responsible for the high saturation currents of these films.
- The recent publication from the American Institute for Chemical Engineers presents some interesting results on the diffusion of sodium through molybdenum; however, it is nothing that can help engineer the sodium content in CIGS absorbers.
- This project focuses on a fundamental understanding of how sodium impacts the properties of CIGS thin films, irrespective of their processing methods. The goals

are to identify the pathways through which sodium improves CIGS devices and to demonstrate a sodium incorporation scheme that gives equivalent performance levels for different substrates from CIGS films deposited in prototype manufacturing tools, such as roll-to-roll physical vapor deposition and precursor selenization. The project is relevant, but most CIGS processes have empirical sodium processes of one kind or another; this project has yet to determine sufficient fundamentals to create better pathways or processes.

- The views on funding were mixed, as reviewers thought the funding amount was either a good value, appropriate, or high.
- The project's impact is limited; its data seem to repeat and convey already known effects. Alternately, the potential impact of this project could be very high. However, the approach is convoluted, not insightful, and is nothing new to what has been attempted and known for many years. The publication record of this project is a reflection of that.
- Such a fundamental study could lead to an understanding of sodium doping in CIGS cells, along with their originality. However, it is not clear how such findings will be implemented into solar cell designs and processing, thereby achieving the ultimate high-efficiency PVs through this fundamental mechanism study.
- Its weaknesses include lack of innovation (vis-a-vis methods or concepts) or predictive data/models. Moreover, the title of this project is deceiving; a reviewer might expect to learn from the difference in the diffusivity of the sodium and grain boundaries, a comparison of different CIGS films, and grain cores. Sodium has neither been mapped nor studied in CIGS, but rather, only through molybdenum.

## PROJECT: 5403 NORTH CAROLINA STATE UNIVERSITY

### *Technology Enabling Ultra High Concentration Multi-Junction Solar Cell*

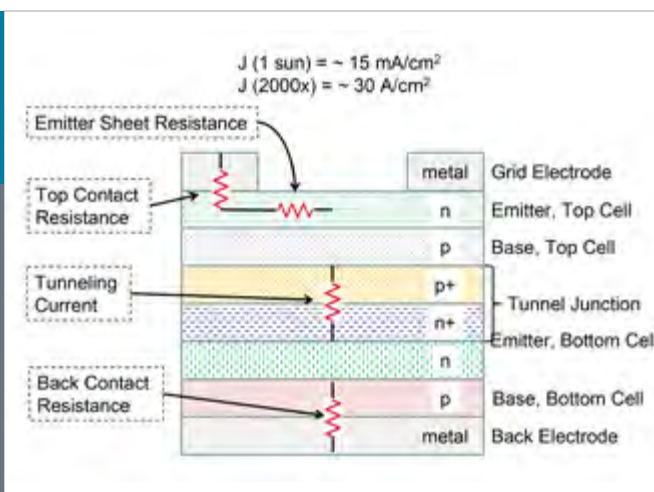

**FUNDING INFORMATION** \$1.0M | Foundational Program to Advance Cell Efficiency 1 | 09/2011–11/2014

### Project Description

A major opportunity for improving cost efficiency in concentrated PV (CPV) systems lies in operating at higher solar energy concentrations. In collaboration with Spectrolab, this project is designing a tunnel junction between the top and middle cells of an indium gallium phosphide/gallium arsenide/germanium (InGaP/GaAs/Ge) triple-junction structure that is functional at a concentration of 2,000 suns. The researchers are growing the tunnel junction from aluminum gallium arsenide (AlGaAs) and InGaP while using very thin AlGaAs layers to inhibit diffusion.

### Individual Reviewer Comments

- The evaluation of the idea of reducing the cost of solar modules by using high solar concentration and high-efficiency multi-junction solar cells is in line with the program; however, it would be interesting to see the targeted values in order to assess the impact of the peak current results that were obtained. The fact that technology transfer happens to a company is also very much aligned with the interest and relevance of the program. Additionally, the funding seems to be appropriate for a three-year project.
- The approach is clear and the results that have been obtained thus far are interesting; however, it all seems a bit dated. This work tackles a small part of the optimization for multi-junction solar cells puzzle. A further reduction of parasitic resistance loss is important where concentration factors are expected to rise; however, when seen from an industry perspective, it

seems unlikely that concentration factors above 1,000 times will become prevalent in refractive CPV systems. Reflective or heliostat CPV configurations may require a higher concentration factor sooner.

- The project has successfully enhanced the peak tunneling current of standard AlGaAs/GaInP tunnel junctions with the insertion of a thin GaAs layer to aid tunneling of both electrons and holes across the junction.
- One useful piece of information that is missing from the work is a comparison of the transmissivity of the standard and quantum well-enhanced tunnel junction. The quantum well absorption is expected to be very small, but as the optical design of these cells progresses, parasitic absorption losses of luminescent coupling photons will also become important. The second task of the project—which is concerned with the optimization of the front window and emitter layers of the top junction to reduce sheet resistance to a target of 250 ohms per square while retaining high-quantum efficiency at short wavelengths—is almost unrepresented on the poster and paper. However, the technology transfer to industry partner, Spectrolab, appears to be underway, so more concrete results may be expected soon. Given its participation, the contribution from Spectrolab has been unimpressive. Its contribution appears to have been very small; few results have been reported.
- This project incrementally improved III-V solar cells and probably carried this out better than industry alone.
- The high concentration has minor applicability to cost reduction, especially in distributed generation.

## PROJECT: 5405 UNIVERSITY OF ILLINOIS

### *Novel Contact Materials for Improved Performance CdTe Solar Cells*

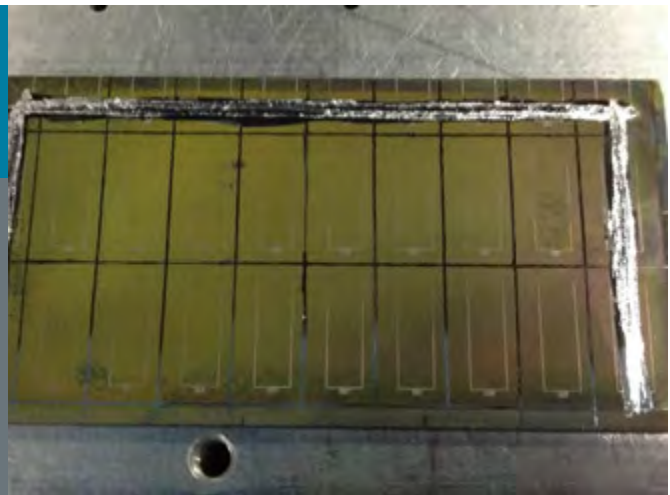

**FUNDING INFORMATION** \$1.1M | Foundational Program to Advance Cell Efficiency 1 | 09/2011–11/2014

## Project Description

This project is developing new materials for front and back contacts used in cadmium telluride (CdTe) photovoltaic (PV) cells. The new materials will reduce the back-contact barrier to zero and produce an ohmic contact, which increases the current flow, and, thus, the efficiency of the PV cell. These advances are expected to increase device performance and process flexibility, providing lowered costs and greater yields.

## Individual Reviewer Comments

- The project features a strong team. The team initially explored a large number of materials (with large work functions) as potential ohmic back contacts (N-doped copper indium gallium selenide [CIGS], hydrogenated amorphous silicon [a-Si:H], and transition metal nitrides), then focused only on those that gave promising results (N-doped CIGS, zirconium nitride [ZrN], and ion-implanted CdTe).
- The project aims to improve CdTe PV efficiency by producing a better back contact (e.g., eliminate the Schottky barrier). Device redesigns (e.g., substrate stacks) are also under study. While most of the contacts were not promising, a few potentially promising alternatives have been discovered.
- The team has generated some positive results investigating a variety of new contact materials and dopants. However, to date, the results have been very inconsistent.
- This project appears to be tackling the problem of improving the p-type contact to CdTe solar cells by attempting to choose materials which would be well suited to forming an ohmic contact to the valence band of CdTe. How the materials are chosen appears to be somewhat arbitrary, with almost an air of, “if it is in the laboratory we can try it.” The two tasks of the project seem to be producing mixed results. The development of p-type contact materials has been partially successful, but with variability in the results suggesting that not all critical process parameters are being sufficiently controlled.
- While it is undeniably an experimental study, it seems that some additional effort on the simulation of the materials and the material interfaces may shed light on the reasons why seemingly promising material combinations are turning out to be suboptimal (and worse than the current standard techniques). For the experiment that tests novel transition metal nitrides, it would also be useful to identify reasons why the materials ought to work before the experimental efforts show a persistent Schottky contact. Given the known, yet often unexplained behavior of CdTe grain boundaries, it would seem sensible to approach this problem by examining how the materials may be acting at the contact interface at the microscopic level.
- One obvious measurement (temperature-dependent IV characteristics) appears not to have been performed, thus locking out potential high-value information from the samples for the Principle Investigator. The reviewer wonders about the funding level, since, apparently, the cryostat/low-temperature apparatus has been defective for some time.
- CdTe back contact exploration/optimization is a mature area. The fact that the project has not developed an improved contact may suggest that contact formation on CdTe is, unsurprisingly, a complex phenomenon (due to Fermi pinning, diffusion, interlayers, etc.). There is a good chance that none of the selected materials will work, and, unfortunately, the project seems unlikely to determine the reasons why a given contact underperforms (thus giving little conceptual insight to the community). Redesign as a substrate geometry seems like a “Hail Mary” and is, perhaps, not possible within the time frame of the project.



## PROJECT: 5407 UNIVERSITY OF DELAWARE

### *Advanced Precursor Reaction Processing for $\text{Cu(InGa)(SeS)}_2$ Solar Cells*

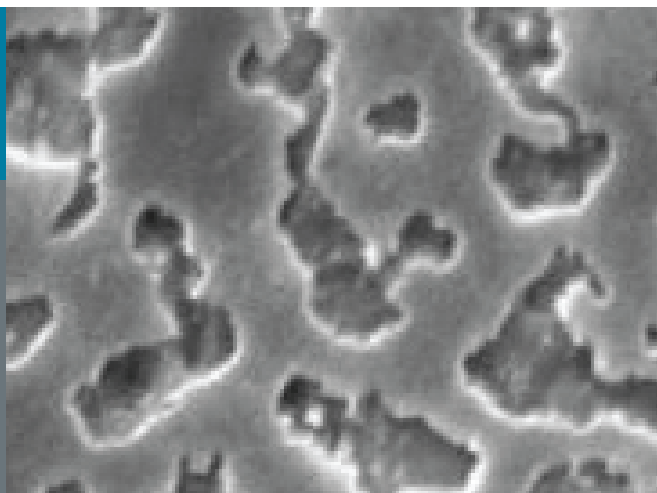

**FUNDING INFORMATION** \$1.0M | Foundational Program to Advance Cell Efficiency 1 | 09/2011–11/2014

### Project Description

This project seeks to improve the manufacturability of copper indium gallium selenide (CIGS)-based photovoltaic (PV) modules by advancing the precursor reaction approach currently employed by a number of commercial entities. In partnership with the University of Florida, the researchers are investigating pathways to improved module performance and yield by modifying the interface between the CIGS absorber layer and molybdenum (Mo) back contact, and increased throughput by studying precursor structures for rapid (less than 5 minute) processing. This approach can also allow for the omission of toxic hydrogen selenide ( $\text{H}_2\text{Se}$ ) gas from the manufacturing process.

### Individual Reviewer Comments

- Adhesion, void formation, elemental segregation, and impurity phase separation are important practical problems for CIGS devices. The project has clear goals and offers a multi-pronged approach to dealing with several of these problems, including investigating selenium capping and annealing, silver alloying, and the use of interlayers at the Mo surface.
- There has been good progress on adhesion, gallium accumulation, reducing voids, sidestepping  $\text{H}_2\text{Se}$ , and reducing annealing times to five minutes, along with a credible route to further improvements.
- Efforts to use other elements to reduce voids, improve adhesion, improve the open-circuit voltage and reduce the seleno/sulfurization times are very relevant to making CIGS a competitive technology in the PV landscape.
- High quality experimental investigations of the effects of a variety of elemental substitutions—especially silver—have been performed. Additionally, positive results regarding void reduction, adhesion, and processing times have been demonstrated.
- The project is very well designed, connecting the needs for improving industrial processes with profound scientific approaches. The objectives were carefully chosen and important results were obtained. Fast processing, as it was investigated in the project, is the major issue in the industrial manufacturing of CIGS modules.
- Of further importance is the question of adhesion. The project investigates this topic very seriously. Whether or not the approach of using silver alloying is the most obvious approach, one should be clarified of this in the discussions. The balance between the amount of funding and the quantity of results is very favorable.
- The degree to which this project is hypothesis-driven is unclear. The criteria for selecting the interlayers and choosing silver alloying were not shared. The experimental approach is reasonable, but may not provide the detailed insights needed to deeply understand the changes in adhesion, elemental separation, and device performance. No efficiency improvements have been demonstrated yet.

**PROJECT: 5948**  
**ARIZONA STATE UNIVERSITY**

*In-situ X-ray  
 Nanocharacterization of Defect  
 Kinetics in Solar Cell Materials*

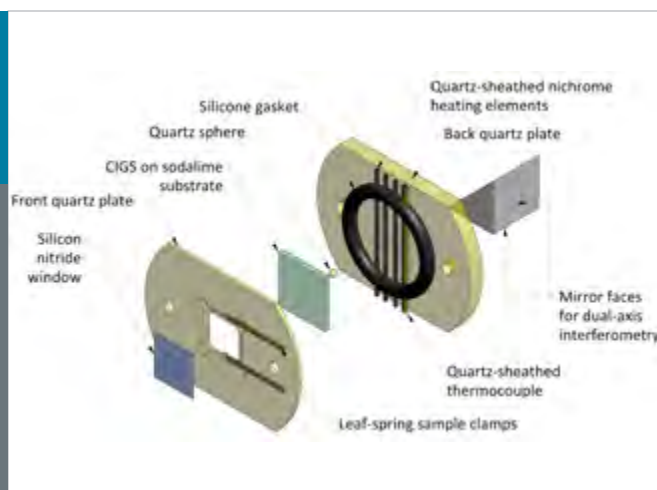

**FUNDING INFORMATION** \$0.85M | Bridging Research Interactions through Collaborative Development Grants in Energy | 12/2012–12/2015

## Project Description

This collaborative research team is addressing the non-radiative recombination that limits the open-circuit voltage of Cu(In,Ga)Se<sub>2</sub> copper indium gallium selenide (CIGS). The team is utilizing in-situ synchrotron-based nano-X-ray fluorescence microscopy (nano-XRF) and x-ray absorption nanospectroscopy (nano-XAS), coupled with nano-x-ray beam induced current (nano-XBIC), to understand the mechanisms that govern the electronic activity at grain boundaries and dislocations in CIGS absorber layers under operating, processing, and growth conditions.

## Individual Reviewer Comments

- This is a very well thought out research and development project that addresses a critical knowledge gap for the development of high-efficiency CIGS and similar photovoltaic. To date, progress has been excellent. The project is cost effective and has very good teaming.

- The team has developed what appears to be an effective tool for elemental characterization at the nanoscale, which can be used to interrogate the spatial effects of defects on the performance of polycrystalline thin-film materials. There are some suggested findings that could lead to the improvement of a CIGS device, though at this point, it is mostly speculation.
- The team provides useful insights at the small scale that are important to any thin film, particularly compound semiconductors. This could be relevant beyond CIGS.
- The project clearly cannot be addressed by industry, and without government support, it will not progress. A funding-related concern is that the work will most likely reveal multiple questions that will require additional R&D on the technique developed in this project.

## PROJECT: 5951 SLAC- THE LELAND STANFORD JUNIOR UNIVERSITY

### *In-Situ X-Ray Analysis of Rapid Thermal Processing for Thin-Film Solar Cells: Closing the Gap between Production and Laboratory Efficiency*

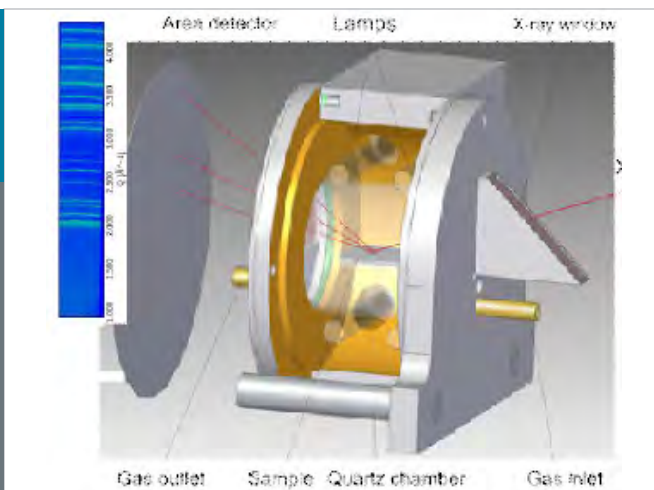

**FUNDING INFORMATION** \$0.9M | Bridging Research Interactions through Collaborative Development Grants in Energy | 11/2012–11/2015

### Project Description

This project seeks to develop a rapid-thermal-processing/X-ray-diffraction and fluorescence facility (RTP/XRD-F) for in-situ, real-time investigations of the structural and chemical evolution of photovoltaic (PV) materials from the initial precursors to final products. It will enable better processing steps to yield higher efficiency, less expensive devices, and will be used for copper indium gallium selenide (CIGS),  $\text{Cu}_2\text{ZnSnS}_4$  (CZTS), indium-free transparent conducting oxides, and metal contacts to silicon cells.

### Individual Reviewer Comments

- This project is very relevant to “bridging” basic research and industrially relevant PV technologies. The concept is challenging; however, understanding phase changes during growth conditions is fundamental to tuning processes and optimizing devices. The approach of using X-ray diffraction seems appropriate to follow compositional and phase changes during growth; however, it’s hard to envision how successful this project will be since all the testing thus far has been on the contact formation of silver on silicon. Moreover, there will be innumerable challenges when trying to move to CIGS/CZTS.
- The main strength of this project is a capability that not many beams count with: a rapid thermal processing (RTP) stage capable of ramping  $100^\circ\text{C}/\text{second}$  to a maximum temperature of  $1,200^\circ\text{C}$  with a time resolution of less than 100 milliseconds (ms).
- The project corresponds well to the bridging of fundamental science and the real-world challenges of PV technology approach with regard to its use of in-situ X-ray spectroscopy, which has been proven in the past to be an important experimental tool to optimize real-world

growth processes of photovoltaic absorber materials.

Thus, the project is based on effective ideas from the past, and is on a learning curve in so far that lessons learned are implemented in its strategy. The project appears to be on track; however, the most difficult step—the design of the second chamber—has yet to be done. If successful, the project money will have been very well spent. It is especially appreciated that processes other than thin-film growth are also investigated with the same setup.

- The basic premise of the project is the development of a capability for material science studies. The common thin-film materials are well suited to such a study. Generally, the capability may find a broader applicability. In regard to RTP processing of thin-film materials, it is not really clear what the required capabilities are to effectively study crystallization processes, so it is difficult to argue whether or not this new capability is essential or sufficient in its specification.
- The funding level is appropriate for the project’s proposed goals. However, the next phase of this project should be considered exploratory. Only the results will tell whether the increased understanding derived from studies of thin films will lead to increases in efficiency and decreases in cost.
- On the downside, this is an averaging technique. The spot size of BL 7.2 is 0.5 millimeters, so the development of a fluorescence capability on the second part of the project for CIGS and CZTS seems pointless. Questions regarding Se/S implementation need to be addressed. If all works out, its influence on the thin-film community could be high; however, it is hard to assess the challenges with a test specimen so dissimilar to the proposed quaternary systems.

## PROJECT: 5953 PLANT PV, INC.

### *Three-Dimensional Minority Carrier Lifetime Mapping of Thin Film Semiconductors for Solar Cell Applications*

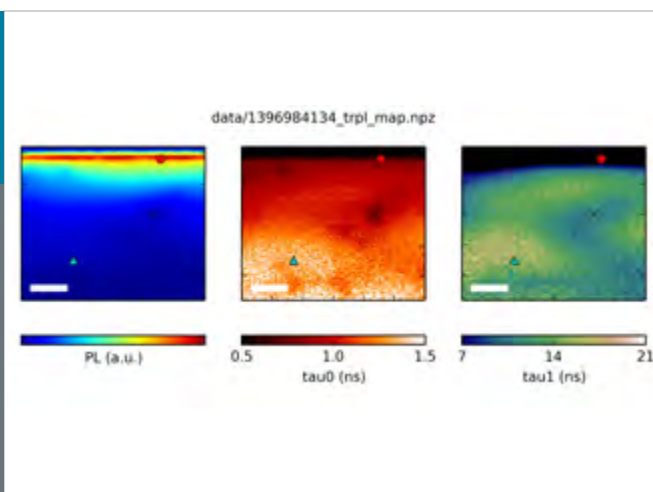

**FUNDING INFORMATION** \$0.45M | Bridging Research Interactions through Collaborative Development Grants in Energy | 11/2012–11/2015

## Project Description

This project seeks to address the difficulty of accurately measuring bulk minority carrier lifetimes in novel semiconductor materials for thin-film photovoltaic (PV) cells. Plant PV is developing a two-photon lifetime tomography technique to separate bulk minority carrier lifetime from surface recombination effects. This technique will enable the rapid screening of PV materials by avoiding the need to construct full devices. This project will also develop three-dimensional minority carrier lifetime and charge collection efficiency maps that will be useful in identifying efficiency bottlenecks for new and conventional (e.g., cadmium telluride, copper indium gallium selenide) thin-film PV materials.

## Individual Reviewer Comments

- The team has developed a technique to directly measure bulk lifetime that is not limited by surface effects like traditional time-resolved photoluminescence. Presumably, this technique can be used to perform 3D profiling of material carrier lifetime. This project is technically interesting and has high-quality work, but it does not meet the understanding of BRIDGE.
- This is a collaboration between two research and development institutions (one is private); the U.S. Department of Energy primarily funds both.
- Additional characterization and validation of real solar cell materials, as well as a correlation with subsequent devices, is needed.

## PROJECT: 5956 UNIVERSITY OF ILLINOIS

*How Grain Boundaries Affect the Efficiency of Poly-CdTe Solar Cells: A Fundamental Atomic-scale Study of Grain Boundary Dislocation Cores Using CdTe bi-crystal Thin Films*

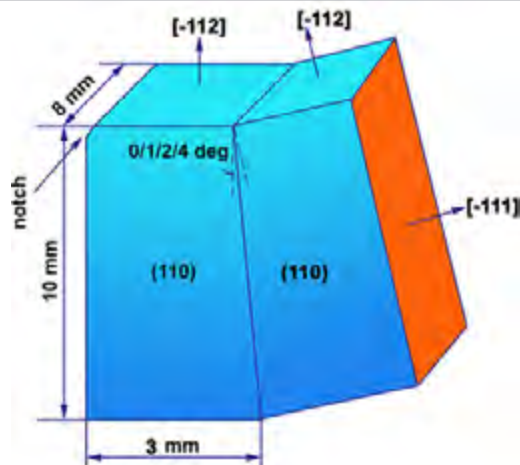

**FUNDING INFORMATION** \$0.90M | Bridging Research Interactions through Collaborative Development Grants in Energy | 11/2012–11/2015

### Project Description

This team is developing a fundamental understanding of the role of grain boundaries on the minority carrier lifetime and  $V_{oc}$  in cadmium telluride (CdTe) thin films by: (1) fabricating epitaxial CdTe thin films on b-crystal substrates with well-defined grain boundary structures; (2) studying the atomic and electronic structures of the grain boundary dislocation cores and interfacial transport properties; and (3) performing first-principles calculations to determine the density of mid-gap states and find potential passivants.

### Individual Reviewer Comments

- An atomic scale understanding of defects in any thin-film material is of utmost importance to design defect engineering techniques and defect resistant device architectures. This is also very relevant to the BRIDGE program goals. The approach is excellent and ambitious, producing CdTe bi-crystal substrates by molecular beam epitaxy (MBE) and characterizing them by scanning transmission electron microscopy (STEM) should shed light on the fundamental correlation between point defects, structural defects, and electronic transport measurements.
- This project has a complex, but fundamentally clean approach to studying engineered grain boundaries. The program is well structured and covers the bases of theory, characterization, and fabrication.
- The one arguable point of the project is how representative these bicrystals are of the performance of real polycrystalline films and how much statistical representation can be acquired using STEM approaches. The team is well qualified to put many of the different pieces together; however, it is questionable how representative the finding will be when it is compared to poly-CdTe.
- The project aims at a very specific goal; namely, the preparation of specific grain boundaries of CdTe via MBE growth on by-crystals. Similar approaches have been successfully used to investigate grain boundaries in other materials. Whether or not such an approach is appropriate to create a useful model system for polycrystalline CdTe films is arguable. The project should consider more explicit results that are independently gained from grain boundaries in polycrystalline films to cross-check the relevance of their approach. However, if the project leads to results that can be transferred from the model system to the real device material, the money is well spent.
- CdTe grain boundaries have a long experimental history of being electrically active, which makes them a good subject of study. Any result is likely positive in regards to understanding grain boundaries in CdTe.
- Translation from these model grain boundaries to actual poly-crystalline films will not be straightforward; they will very likely be beyond the project's scope.

## PROJECT: 5957 UNIVERSITY OF OREGON

### *Vapor Transport Deposition for III-V Photovoltaics*



**FUNDING INFORMATION** \$0.45M | Bridging Research Interactions through Collaborative Development Grants in Energy | 11/2012–11/2015

### Project Description

Scientists at the University of Oregon are researching vapor transport deposition technology for III-V solar materials. Using photoelectrochemical test cells, they have shown that n-doped Gallium Arsenide (n-GaAs) deposited in a simple close-space vapor transport reactor has diffusion lengths of  $1.5\ \mu\text{m}$ -1 even when deposited at rates of approximately  $0.5\ \mu\text{m min}^{-1}$ . Device physics simulations show that by controlling doping and forming solid-state junctions, AM1.5G (air mass global) efficiencies of greater than 24% should be attainable.

### Individual Reviewer Comments

- Overall, this is a good project that tackles a fundamental area of III-V deposition rates. This project shows a very promising start to a new deposition technique for GaAs, as it aims to increase precursor usage efficiency and GaAs growth rates when compared with traditional metal organic chemical vapor deposition techniques. With sufficiently high growth rates and the ease of manufactured and material quality, the promise of III-V materials as cost-effective one-sun PV devices comes closer to reality. Funding at \$150,000 per year for 3 years seems to be a very good monetary value given the results.
- A strength of the program is its novel technique to remove the gas-based precursors from the formation of GaAs films, increased deposition rates, and source utilization. The project has been able to demonstrate film

deposition and doping, with measured film properties reported to enable 25% efficiency; however, these films have not yet translated this into functioning solar cells. It is unclear if the program has the required capabilities to do this.

- Thus far, the project has been successful in demonstrating high-quality material, doping control, and growth rates—though not in a real solar cell device. A thorough investigation of the material properties of the grown films has shown positive results.
- The approach is novel. If solar cells can be manufactured like this, then the impact of the project will be rated highly against the goals of the SunShot program.
- This project uses vapor transport as a potentially low-cost means of growing III-V films for PV applications. It appears to have great potential; however, more information is needed regarding the growth methods in order to assess its promise. Nevertheless, good progress in materials growth has been reported.
- It is doubtful that growth processes taking place at  $850^\circ\text{C}$  will be compatible with using silicon as a substrate or even an active subcell in a multi-junction stack. However, the work is not finished, as it will be important to develop passivation layers and other components of potential future multi-junction designs.
- It became apparent during the review session that the other films that are required for the full manufacturing

of a GaAs cell using this technique are very challenging. This is something that would need to be resolved to unlock any benefit from this approach. The key parameters that might amount to a breakthrough in this new approach would be cost and/or film properties.

- The project has focused on film properties, but it has not provided any details on cost or scalability as a key

parameter of this new technique. If, for example, a high-quality substrate is required to seed the deposition, then the new technique does not resolve the cost barrier. It is unclear from the provided information how the growth on silicon will provide a workable solution for the beyond SunShot objectives. Application aside, it does not seem that this approach is dependent on closed-space vapor transport; therefore, it could utilize any GaAs deposition technique.

## PROJECT: 5958 UNIVERSITY OF TEXAS AT EL PASO

*Collaborative Atomic-scale Design, Analysis, and Nanofabrication for Record Breaking, Single-crystal  $Zn_xCd_{1-x}Te$  Solar Cell Arrays*

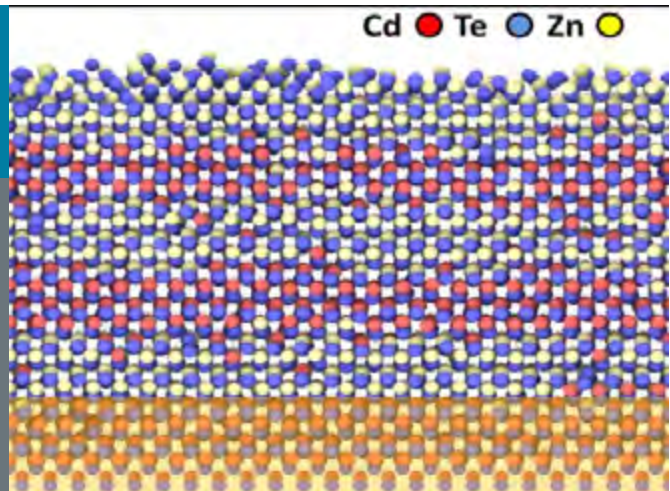

**FUNDING INFORMATION** \$0.9M | Bridging Research Interactions through Collaborative Development Grants in Energy | 11/2012–11/2015

### Project Description

The goal of this project is to create a new collaborative capability to work around fundamental barriers to achieving high open-circuit voltages ( $V_{oc} \geq 1.0$  volt [V]) in cadmium telluride (CdTe)/CdS solar cells. The project will create a patterned thin-film design, deposition, and analysis capability to create uniform  $Zn_xCd_{1-x}Te$ /CdS solar cell arrays that will reduce the defect-density from  $10^{14}$  to  $10^{12}$  cubic meters and increase the  $V_{oc}$  from 0.85 V to 1.0 V.

### Individual Reviewer Comments

- The project idea is based on the nanopatterning of substrates for the growth of epitaxial CdTe. This approach allows for the growth of individual micro-grains with potentially better crystalline quality. The project idea appears to be somewhat exotic and too far away from real-world application. A clear strategy for how expected results might fit into a road map for improving CdTe modules is not clear.
- The understanding of defects and interfaces in thin-film materials is of high relevance to the BRIDGE program; however, it is hard to identify what this particular project wants to achieve. Addressing the efficiency barriers that are associated with both of the interfaces and the spatial/morphological non-uniformity of polycrystalline CdTe/cadmium selenide (CdS) solar cells is ambitious, because there has to be a clear path to deconvolute the device behavior that originates from each of them (this

may have been explained in the full proposal; however, the reviewer has no access to it).

- The project motivation hypothesizes that CdS/CdTe lattice mismatch is a primary source of voltage shortfall in CdTe devices. There is no clear identification of the root cause of the voltage shortfall in CdTe devices; however, low doping, difficulties forming appropriate contacts, absorber lifetime, and hetero-interfaces are typically considered just as important.
- In the proposed approach, the choice of zinc telluride (ZnTe) as a buffer layer between CdS and CdTe may be troublesome. If the ZnTe layer is made thick, then the proposed device configuration will simply reflect a CdS/ZnTe device and no conclusion can be reached regarding the influence of CdS/CdTe lattice mismatch on device performance. In this structure, a high voltage may be achievable, but through a loss of current. If the zinc introduction is graded, then this type of enlarging of the bandgap to the junction, which is known as “front grading,” will likely be detrimental to the device performance. This will prevent effective carrier collection and further impair the fill factor of the structure. Furthermore, the presence of CdS will make it difficult to achieve high-current density and the target goal of 25% efficiency.
- This different way of studying model systems invites a host of new problems into the process flow. The substrate is nano-crystalline, and although the grains



will be controlled at a small size, the grain surface still needs to be passivated. The introduction of zinc into the system further decreases the likelihood of learning anything of particular significance to poly-crystalline traditional.

- From the information given, the reviewer gathers that the defects in question in this project are mainly dislocations. While assessing the dislocation recombination strength is very important, it is very possible that the effect of dislocations is completely washed away by the effect of grain boundaries, which have been shown to be the cause of the low  $V_{oc}$  in many thin-film

systems. The growth of zinc-rich films in between stubs of silicon dioxide does not seem to be well thought out. Zinc towards the back is better for lattice matching, but it widens the gap, making carrier generation happen at the front mostly. The main problem with this is that the IV measured with this structure—which barely shows diode behavior—now has a third dimension to it.

- The quality of the epitaxial films grown on nanocrystalline CdS is questionable, as is the representativeness of the dislocation content to a real device. Furthermore, the character of the dislocations is never mentioned in the approach.

## PROJECT: 5959 UNIVERSITY OF UTAH

### *Novel Photon Management for Thin-Film Photovoltaics*

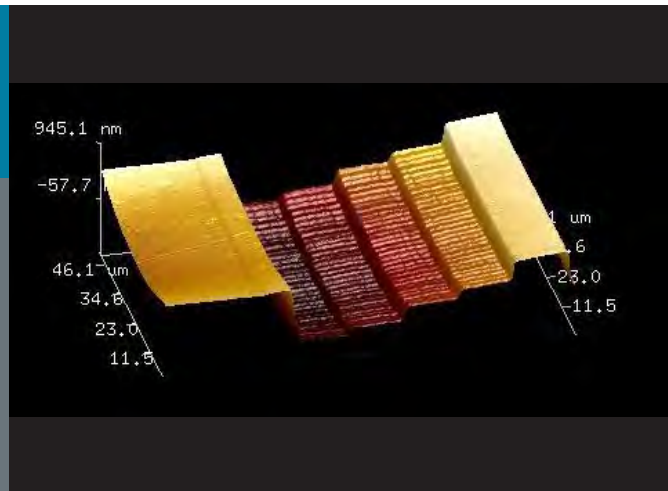

**FUNDING INFORMATION** \$0.45M | Bridging Research Interactions through Collaborative Development Grants in Energy | 11/2012–11/2015

### Project Description

The objective of this project is to enable commercially viable thin-film photovoltaics (PV) with efficiencies greater than 20% using a novel optical spectral-separation technique at costs below current technologies. The team is developing processes for cost-effective manufacturing of integrated arrays of PV cells for manufacturing polychromats in glass and for packaging the entire device.

### Individual Reviewer Comments

- Photon management—particularly, splitting the solar spectrum into different parts according to different absorber materials—is an important issue. The proposed concept appears interesting though somewhat exotic. Some important questions, such as the dependence of the device output on the direction of the incident light, are not clear from the report. The importance of the results could be clarified through a comparison of the present figure of merits to alternative approaches of spectral splitting.
- The project offers an innovative, easily-made spectrum splitter concept. The approach is innovative and easy if it is efficacious. Due to the originality of this approach, the relatively modest funding level is appropriate provided that at the end of the project, a prototype device is presented and the advantages and disadvantages of this device are properly evaluated in comparison to standard approaches.
- The project presents an alternative approach to traditionally straightforward and expensive multi-junction cell design. It has done terrific work on the optical optimization of the elements. Unfortunately, similar complex analysis may be required to understand whether this approach has economic merit. The basic merit of this approach for spectral splitting to be a clear path to success is unclear. Only through a discussion with the Principle Investigator during Q&A did it become apparent that a thin-film fabrication thrust is tied to this effort. Reviewers were unable to review this at any depth.
- The relevance of the project is low, given that few cells are available in commercial quantities and sizes that are well suited to spectrum splitting. Given that its experimental results have been disappointing, its impact is also low. Functional viability is another concern.

## PROJECT: 5960 SLAC NATIONAL ACCELERATOR LABORATORY

### *In-situ Roll-to-Roll Printing of Highly Efficient Organic Solar Cells*

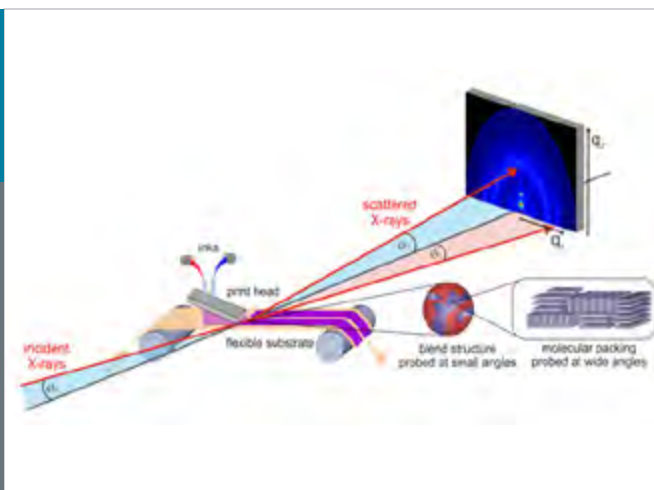

**FUNDING INFORMATION** \$0.88M | Bridging Research Interactions through Collaborative Development Grants in Energy | 11/2012–11/2015

### Project Description

The objective of this project is to develop a roll-to-roll printing setup for organic solar cells that will capture important aspects of existing industrial printing methods will allow the printing process to be studied in-situ with both small- and wide-angle X-ray scattering. This novel ability will enable a more rapid rate of improvement in solar cell performance by allowing the team to directly tune the printing conditions and the ink formulations based on the feedback from the scattering experiments.

### Individual Reviewer Comments

- The project focuses on an important area of organic photovoltaics (OPV) (improving the efficiency of rapidly-printed OPV relative to spun OPV, which is a higher-cost, batch process). The investigated solution-shearing approach seems to access different microstructures than does spin coating (e.g., smaller domain sizes and chain orientation in all-polymer cells) that show some efficiency enhancement (albeit at low efficiencies of approximately 4%). The ability to make high-resolution movies of film ordering during the deposition process could have wide utility for several different PV technologies (e.g., OPV and quantum dot PV).
- The team has developed the system and has generated preliminary results on OPV films that would indicate real utility in OPV manufacturing. This project analyzes the microstructure of solution shear-processed

poly-3-hexylthiophene/phenyl-C61-butyric acid methyl ester (P3HT/PCBM) bulk heterojunction solar cells using in situ X-ray diffraction. It is a unique approach with considerable power for diagnosing and potentially controlling film deposition in a roll-to-roll context.

- The approach appears to be thorough, high-quality materials science. It remains to be seen if these techniques will come together in such a way that significantly improves OPV performance when deposited on rolls of substrates.
- The characterized films have such low efficiency—even for OPV—that they would still invite considerable skepticism as to the real impact that this approach could have down the road.
- The proof-of-principle demonstration that selected P3HT/PCBM is perhaps not a good example of the power of this in-situ technique, considering that the detail of the provided information is overkill (simple ex-situ checks would give the same printing speed-morphology results with much less work). However, this technique could be uniquely insightful for other systems.
- Cell efficiencies are low; a route toward 20% is not demonstrated.

## PROJECT: 6322 DELAWARE STATE UNIVERSITY

### *High Efficiency Thin Film Fe<sub>2</sub>SiS<sub>4</sub> and Fe<sub>2</sub>GeS<sub>4</sub>-based Cells Prepared from Low-Cost Solution Precursors*

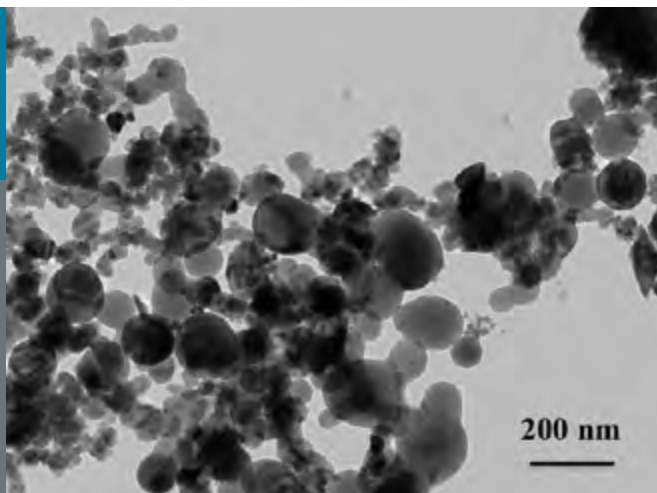

**FUNDING INFORMATION** \$0.33M | Diversity in Science and Technology Advances

### Project Description

The objectives of this project are to introduce a solar course at Delaware State University and initiate a solar research program to debut with the development of a novel thin-film photovoltaic (PV) technology using solution nano-precursors to Fe<sub>2</sub>SiS<sub>4</sub> and Fe<sub>2</sub>GeS<sub>4</sub>-based absorber layers in solar devices. This technology aims to create low-cost solar cells by using the solution processing of sustainable, inexpensive materials, coupled with reduced installation costs by enabling the use of lightweight, flexible substrates. The solar cell devices target an efficiency of at least 5%.

### Individual Reviewer Comments

- Based on theory, Fe<sub>2</sub>SiS<sub>4</sub> and Fe<sub>2</sub>GeS<sub>4</sub> have strong potential as PV absorbers, but almost zero experimental work has explored them for PV. Although the project started just several months ago, a few routes to making the films have been explored (sintering of amorphous material to make Fe<sub>2</sub>GeS<sub>4</sub> and sintering of mixed-phase silicon and FeS<sub>2</sub> nanoparticles to make Fe<sub>2</sub>SiS<sub>4</sub>). Preliminary device stacks have also been created.
- The project has a good educational component, including a new PV course planned for fall 2014. The educational component is important and relevant, but it is too early to assess its success or implementation since the project started only a couple of months back.
- The goal of greater than 7% efficiency is ambitious, given that no one has explored this system for PV applications. The idea of “if CZTS can do it, so can we” is a bit optimistic for this system.
- The project is relevant to the Distance program but the funding is way too low for a three-year project. The project is in its very early stage and the impact of the overall work is not yet evident.
- The major approach in this work is to synthesize high-efficiency Fe<sub>2</sub>SiS<sub>4</sub> and Fe<sub>2</sub>GeS<sub>4</sub>-based solar cells using a solution-based process. However, it is not very clear why this system is selected and if the solution-based technique can produce high-quality cells with high efficiency. The phase and morphology of the films look less than promising, but this project just started.
- Nanoparticles have been synthesized and ready for the Fe<sub>2</sub>SiS<sub>4</sub> and Fe<sub>2</sub>GeS<sub>4</sub> layer deposition. Progress has been made in the past half year. The concerns of the project are that the quality of the solution-based Fe<sub>2</sub>GeS<sub>4</sub> film and the efficiency could be difficult to compare with other solar cell technology. The solar cell efficiency demonstrated thus far is unclear.
- The justification for using nanoparticle deposition rather than evaporation or another method to make the films is uncertain. Film quality has been low thus far, including grain size and phase impurity problems. Plans to troubleshoot morphology and electrical behavior of the films and device stacks were not described.

## PROJECT: 6334 IBM

### *Driving CZTS to the SQ Limit: Solving the Open Circuit Voltage Problem*

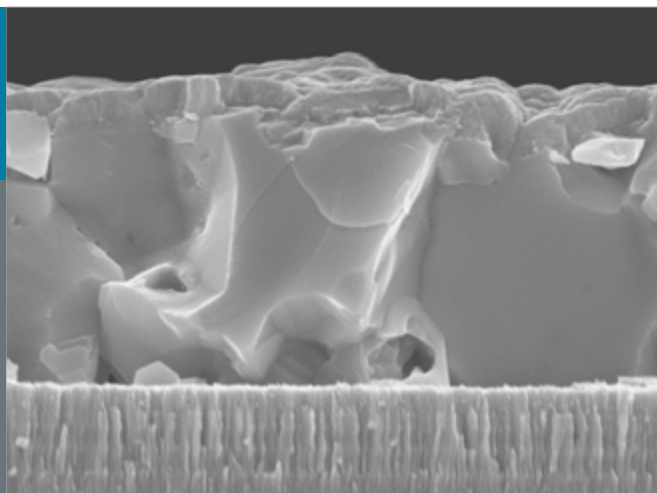

**FUNDING INFORMATION** \$4.4M | Foundational Program to Advance Cell Efficiency 2 | 09/2013–09/2016

### Project Description

IBM is collaborating with the University of Delaware, the University of California in Santa Barbara, and Harvard University to address the open-circuit voltage deficit of copper zinc tin sulfide (CZTS) technology through a single model crystal-based approach. This work will drive voltage and efficiency improvements toward the Shockley-Queisser (SQ) limit with targeted device efficiencies exceeding 18%. Achieving the goals of this project would enable a system that uses relatively abundant material inputs with high performance and potentially low cost.

### Individual Reviewer Comments

- The project's approach to the problem seems thorough and well laid out, covering the most pressing needs toward a single crystal (SX) device demonstration for CZTS. The project also has a strong team that consists of a world-record holder, which gives it an optimal opportunity to transfer previously gained knowledge. Other strengths of the project include a good mix of/access to surface and bulk characterization tools as well as a focus on HVM-compatible CZTS deposition processes.
- The development of the quaternary CZTS material system for photovoltaic absorbers is an unprecedented challenge in terms of materials and device complexity. The project is a cornerstone for furthering the development of this technology, which is thought to replace the CIGS technology in the future in order to save the rare element, indium. The project is well equilibrated between fundamental and technology-related experiments.
- With the use of relatively small amounts of funding, an impressive spectrum of well-balanced actions is planned. The project makes good use of prior knowledge on CIGS absorbers, and represents a clever combination of experiments, theory, and modelling.
- The project's relevance is high, given that CZTS is one of the United States' best shots at intercepting high-volume manufacturing copper indium gallium selenide photovoltaic (PV) industry. Its impact is moderate, as half of the tasks are based on single-crystal and epitaxial materials that may not be representative of PV films. The funding amount of \$4.5 million every 3 years plus a \$1.5 million cost share is good given its multiple participants. Moreover, the approach appears heavily weighted to single-crystal and epitaxial materials and does not directly intersect commercial-style multi-epitaxial thin films.
- Project weaknesses include the heavy weighting of single-crystal and epitaxial materials, a seemingly secondary investigation of surface effects, and a minimal investigation of grain boundaries. Epitaxial quality of growth on silicon seems rather poor with a full width at half maximum of 0.5. More improvement may be required to achieve meaningful SX devices.
- Polycrystalline (Px) CZTS efficiency is only at roughly one third of its SQ entitlement. While model systems can play a significant role in answering key questions for a technology, their use comes at a great price. Hence, it is questionable whether CZTS has reached the state where progress through empiricism is slower than progress through the use of model systems.

## PROJECT: 6335 ARIZONA STATE UNIVERSITY

### *Thin Silicon Solar Cells: A Path to 35% Shockley-Queisser Limits*

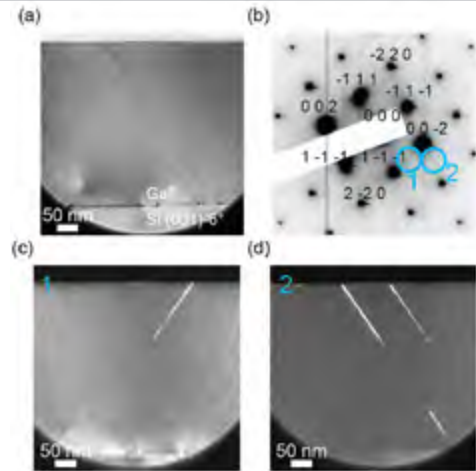

**FUNDING INFORMATION** \$3.4M | Foundational Program to Advance Cell Efficiency 2 | 09/2013–09/2016

## Project Description

Arizona State University is leading a collaborative effort with the Massachusetts Institute of Technology, the California Institute of Technology, the University of New South Wales, and the Swiss Federal Institute of Technology to fabricate a novel device structure for ultra-thin crystalline silicon (c-Si) solar cells based on carrier selective contacts. A series of optical and material innovations will be developed that result in novel ultra-thin silicon solar cells with targeted efficiencies of 29%. If successful, such a cell using carrier selective contacts could approach the Shockley–Queisser (SQ) limit for silicon using a potentially commercializable device structure.

## Individual Reviewer Comments

- The primary focus of the Advancing Photovoltaic (PV) Efficiency program is to address technical barriers that are preventing the future advancement of cell performance. This project is perfectly aligned with this objective, as it focuses on how to break through the present-day practical limits for silicon solar cells. The proposed work could lead to high efficiency silicon-based solar cells approaching the SQ limit of 35%. The impact could be very high if it is successful and priorities are well placed.
- The success of this objective would take the leading solar cell designs—now at 25%-26%—towards 30%. A primary strength of this approach is that once it is demonstrated, these results could conceivably be attached to many of the existing ultra-high-efficiency silicon solar cell structures, and manufacturing process

flows. Improving the efficiency of these devices by an extra 2-3% absolute would provide significant reductions in the cost of energy. Moreover, in combination with other manufacturing cost reduction activities, it would provide a plausible pathway to satisfying the beyond SunShot objectives.

- The large collaborative group that is working on this program enables the team to leverage the background knowledge and facilities of various institutions. This is a strong advantage for a program that is targeting such a fundamental building block.
- The budget is reasonable for a nine-person team. Additionally, the proposed approach is innovative, yet highly challenging and with high risk. Its path to success is unclear. It is certainly beneficial to approach the goal by implementing these approaches to reduce all possible losses; however, it is not clear how all of these approaches can be implemented together to achieve the ultimate goal. It has been a long-term challenge to increase silicon-based PV efficiency.
- Implementing III-V-based heterojunctions on silicon will significantly increase the cost of the cells, which could even approach the cost of a tandem cell. The cost effectiveness of silicon PVs is reduced.
- The project tantalizes with the promise of record solar cells at 27%; however, the challenges in finding a new contacting material should not be underestimated.

- The team is presently focused on passivation parameters; however, for a successful solar cell, the other constraints of optical properties—electrical conductivity, reliability, and process sensitivity—must not be overlooked.
- The practicality of researching across three time zones and five locations must be problematic for rapid cycles of learning (e.g., utilizing previous results for the next steps) and the intellectual sharing of information and thoughts. This somewhat offsets the potential leveraging factor.
- None of the participants have an active solar cell baseline process that approaches current records; hence, it will be challenging to achieve a record within the program timeline. The current focus of the program is to identify an appropriate material; however, the deposition techniques currently under investigation would not be practical for industrial solar cell manufacturing. Some consideration should be given to this roadmap.

## PROJECT: 6336 GEORGIA INSTITUTE OF TECHNOLOGY

### *Overcoming the Fundamental Bottlenecks to a New World-record Silicon Solar Cell*

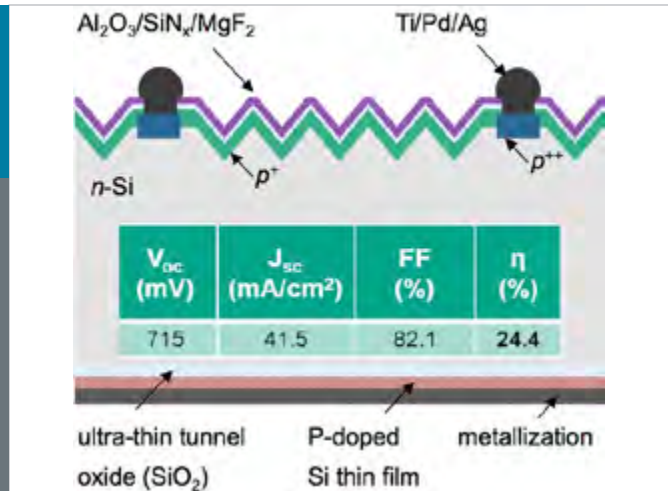

**FUNDING INFORMATION** \$3.5M | Foundational Program to Advance Cell Efficiency 2 | 09/2013–09/2016

### Project Description

The Georgia Institute of Technology has partnered with the National Renewable Energy Laboratory and Fraunhofer Institute for Solar Energy Systems (ISE) to drive crystalline silicon (c-Si) solar cell efficiency past 26.5% through a fundamental and applied research program. The team's approach includes strategies of passivated contacts via tunnel dielectrics, emitter optimization, and enhanced light trapping through the development of photonic crystals and a plasmonic backside reflector. These improvements will help realize efficiency improvements that could be incorporated into the existing silicon photovoltaic (PV) technologies that represent the majority of the current PV market.

### Individual Reviewer Comments

- If successful, this project could lead to high-efficiency silicon-based PVs approaching the theoretical limit of 29% for silicon PVs. The team has made a very clear path way towards a new world record of silicon PV efficiency. Several unique approaches have been proposed to achieve such high efficiency.
- Based on their past performance and the record of silicon-based PV efficiency, the team is very strong. They will be able to carry out this project as planned. Additionally, the partnership with the Institute for Solar Energy Research Hamelin (ISFH) is useful to the objective. ISFH is recognized as one of the leading research institutions for silicon solar cells; hence, much can be learned through this collaboration.
- The funding level is reasonable for a 16-person team. Such an enormous financial and labor commitment has been made to this project in order to achieve this world-record efficiency of silicon PV.
- The project is likely to improve the baseline capabilities of U.S. institutions that are involved in the production of ultra-high efficiency silicon technologies. This program aims to demonstrate world-record cells through a primary strategy of integrating known high-efficiency building blocks—both industrial and laboratory—into a front contact cell. Recent announcements of leaders in cell performance have furthered the efficiency of large area (greater than 130 centimeters squared) silicon solar cells to 25.6%, making the assignment of achieving a world record more challenging. Given the competition, it is unlikely that this program will deliver a world record with the structure that is shown in the timeline of the program.
- The light-trapping scheme illustrated in the report is of interest and could potentially provide a new building block for high efficiency solar cells. Some consideration of how this scheme will perform in real-world conditions could be interesting (e.g., spectrum changes and off-angle light).
- Keeping industrial relevance in mind is important in this program, given that the focus on process integration and the near-term implementation of targeting a world record is a game of learning rates and fundamental building blocks. Generally, the push to thinner



wafers will increase importance of light trapping and new schemes, since this will be relevant. This program should focus more on the development of new building blocks—like this one—other than the integration of known techniques.

- Examining the elements used in this program show several common “laboratory” tricks (e.g., Float Zone wafers, magnesium fluoride double layer antireflection coatings, aperture measurements, and photolithography). This is problematic for the overarching goal of enabling a lower cost of energy in the real world. Should the program successfully demonstrate high efficiency, it will still not provide the guiding light that is needed for industrial implementation.
- The concern is over meeting major challenges and deliverables. Consequently, contingency plans should be considered. Additionally, the absence of an industrial partner is evident in the approach; the project team should take this into consideration. Furthermore, the responsibility of Glunz and the Fraunhofer ISE Systems is not obvious.
- Given that the program will be focusing on performance, it is a weakness of the program not to include any work on the reliability and/or longevity of the resulting devices. Degradation in field conditions is of critical importance for achieving the low cost of energy.

## PROJECT: 6343 STANFORD UNIVERSITY

### *Coupled Thermo-mechanical and Photo-chemical Degradation Mechanisms that Determine Reliability and Operational Lifetimes for CPV Technologies*

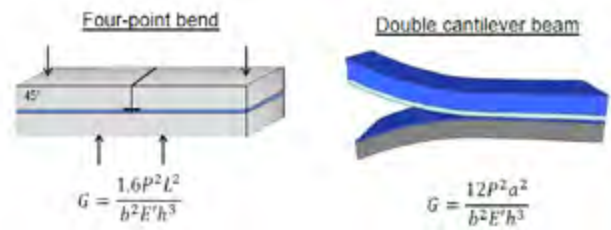

**FUNDING INFORMATION** \$1.1M | Physics of Reliability: Evaluating Design Innovations for Component Technologies in Solar | 09/2013–09/2016

## Project Description

Stanford, in collaboration with the National Renewable Energy Laboratory and Spectrolab, is investigating coupled intrinsic thermo-mechanical and photochemical degradation mechanisms that determine the reliability and operational lifetimes for concentrated photovoltaic (CPV) technologies. The research approach will result in quantitative metrologies to characterize degradation processes during PV operation, detailed kinetic models of degradation mechanisms, and reliability benchmarking of materials and interfaces in CPV devices and modules. The approach is based on fundamental materials science, reliability physics, and the development of accelerated testing protocols for more accurate lifetime predictions.

## Individual Reviewer Comments

- This project focuses on the reliability of CPV, specifically for understanding the key mechanisms of degradation. The objectives of the program are spot-on, focusing on developing models and an understanding of the fundamental degradation modes in CPV. This project is relevant to the SunShot project goals by enabling the further adoption of the highest efficiency CPV technologies—which offer significant reductions in the balance-of-system costs per megawatt-peak—and the lifetime-limiting degradation mechanisms of CPV modules and cells to be measured and quantified.
- The lifetime of any solar technology is intrinsic to the final cost that the technology delivers in the field. The project can also contribute to the wider questions of fundamental degradation processes, which are applicable across many technologies.
- The project's impact on the SunShot goals is positive; the work enhances the community understanding of the degradation mechanisms and impacts, thereby directly reducing the risk and cost of implementing CPV systems.

Fundamental mechanistic studies like this are useful and important.

- Funding seems to be appropriate for the large-scale and long-term testing that is required to carry out the investigation. The approach is reasonable, though it may be potentially skewed by survey data that was received from the parties who the project had approached for input and feedback. Furthermore, experimental design on materials such as silicon, which have very different thermal and chemical properties from the III-V semiconductor family, is questionable. Nevertheless, real devices will also be tested. Of the 12 pathways that were identified as potential reliability risks, it seems that only 1 or 2 have been selected for further investigation. The selected paths may be the most commonly seen failures, but this should not exclude the other degradation or failure mechanisms of this relatively immature technology. However, industry participation and guidance solicitation should be generally encouraged and viewed favorably.
- The promise of kinetic models, benchmarks, characterization, and the development of new test methods are the right areas of emphasis. The collection of partners that is working on this project is appropriate for the objective, as it brings together a collection of needed capabilities. Considering that the program has just started, commenting on the process is difficult; however, it is encouraging that the project team has reached out to a wide range of industry participants. This can ensure that they are working on industry-relevant areas.
- The methodologies and identification of the problem (including polling industry for most frequent failure modes) are appropriate and have the potential to significantly impact the field. The generality of the work is questionable; the PI is focusing on one or two interfaces in specific devices, so it is unclear whether the methods and findings will have broad applicability. The PI should endeavor to answer this.

## PROJECT: 6344 ARIZONA STATE UNIVERSITY

### *Unified Numerical Solver for Device Metastabilities in CdTe Thin-film PV*

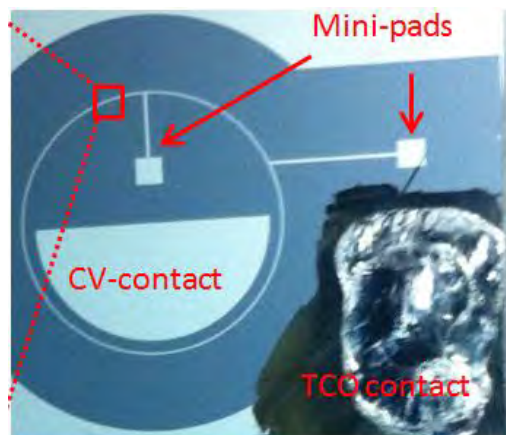

**FUNDING INFORMATION** \$1.4M | Physics of Reliability: Evaluating Design Innovations for Component Technologies in Solar | 09/2013–09/2016

### Project Description

Arizona State University, in collaboration with First Solar, Colorado State University, and National Renewable Energy Laboratory, is developing a tool to study the fundamentals behind the performance and metastabilities of cadmium telluride (CdTe) thin-film photovoltaics (PVs). The core of the solution will be a multi-level solver that combines macroscopic diffusion-reaction equations that describe subsystems of point defects, combined with the global Poisson equation. This will form a closed system that can be solved in time domain and quasi-3D space utilizing cylindrical grains.

### Individual Reviewer Comments

- The subject of performance (degradation) of solar modules and, more specifically, of the intrinsic stability of solar cell absorber materials is most relevant. Taking into account the 100-gigawatt worldwide installed capacity, it is obvious that not enough has been done on this topic. Therefore, the relevance of the project is as high as it can be. Relevance is high given the United States' position in CdTe PV manufacturing and the project's focus on the fundamental understanding of CdTe PV materials that reasonably correspond to HVM reality.
- In the case of CdTe, the fundamental defect physics of the material is thought to play an important role. The combination of expert scientists from the field of reliability and of fundamental materials physics is

highly attractive. The first step envisaged in the project—namely, the combination of conventional device simulator with the atomistic dynamics of defects—is an extremely important attempt. One might ask whether the intended project goal of a 3D simulator is somewhat overambitious in view of the limited funding amount and complex process of comparing experimental data from the laboratory to data outside of the simulation results. Instead, different length and time scales could be well covered by separate programs.

- The approach is promising, but it seems extremely difficult to confirm the linkage between the calculated result and materials reality. Additionally, the project's impact depends on whether a quasi-first-principles model can accurately reflect actual materials and devices (e.g., multi-crystalline films with various purposeful and incidental impurities excluding non-homogeneous processing).
- There is uncertainty about the degree to which calculated results will correlate to materials and device realities. However, in view of the complexity of the subject combined with the importance of the issue, the project appears to be substantially underfunded. Outside data analysis should be included in the project scope in order to make a link between recorded performance degradation and the results of simulations.

- The work focuses on tackling the complex degradation mechanisms of CdTe cells under temporal changes in device performance using mathematical algorithms to build theoretical models. With such a model, it is possible to understand the mechanisms better under time, temperature, and other conditions. The overall impact of several factors (e.g., copper diffusion) on cell band structure and cell performance is considered. Alternately, the budget is considered to be reasonable for a five-person team, but relatively high for such a narrow working scope.
- This project focuses on the development of a theoretical model in predicting the degradation mechanisms in CdTe-based PVs. This is clearly a necessary effort in the overall designing of high-efficiency CdTe with reduced degradations under working environments. It is not clear how this model will be tested through experiments and how it can benefit the overall cell design and processing to optimize the cell structures for minimum degradations.

## PROJECT: 24616 OAK RIDGE NATIONAL LABORATORY

### *Improving $V_{oc}$ of CdTe Thin Film Solar Cells: Understanding and Taming the Grain Boundaries*

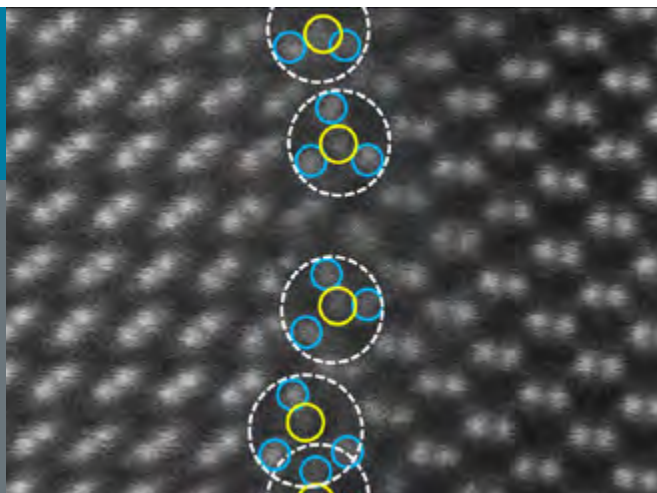

**FUNDING INFORMATION** \$1.0M | Foundational Program to Advance Cell Efficiency 1 | 09/2011–11/2014

### Project Description

This effort aims to develop technologies that can overcome the open-circuit voltage ( $V_{oc}$ ) limitations in cadmium telluride solar cells by understanding and controlling the grain boundaries (e.g., the bounding surface between crystals). The research team is working to improve minority carrier lifetimes from less than a few nanoseconds (ns) to more than 10 ns, which would lead the enhancement of  $V_{oc}$  from 840 millivolts to more than 1 volt.

### Individual Reviewer Comments

- Understanding the mechanism(s) of efficiency enhancement of cadmium telluride (CdTe) photovoltaic by cadmium chloride (CdCl<sub>2</sub>) and copper treatments is an important long-standing challenge that could result in substantial performance improvements. This project combines high-resolution transmission electron microscope imaging (TEM)/spectroscopy/electron beam-induced current (EBIC)/cathodoluminescence with similar scanning electron microscopy (SEM)-based techniques to observe the structure, composition, and activity of grain boundaries, bulk defects, and the CdTe/CdS interface.
- This is a very strong suite of experimental techniques, plus density functional theory, that are used to aid interpretation. There have been several significant results, including an observation that chlorine enrichment likely causes p-n-p junctions at the grain boundaries that assist charge separation. Additionally, sulfur diffusion into CdTe drives the junction some 10 nanometers inside the CdTe.
- The mystery of grain boundaries in CdTe—their plentiful occurrence, yet proportionally reduced detrimental effect on cell efficiency—is certainly an area that merits investigation. The studies performed here are comprehensive and relate to commonly used processes of fabricating CdTe solar cells, which have an enviable market history of low cost. Understanding the role of chlorine- and copper-based treatments in modifying grain boundaries is crucial to the improvement of these solar cells.
- The techniques developed here—while not novel—represent a thorough and systematic investigation of the problem at hand. Therefore, the project's relevance to the program as a whole is positive, as thin-film technologies are widely seen as strong candidates for achieving the low dollar/Watt cost requirement, which was a result of the comparatively small amount of material required to fabricate high-efficiency cells. This is a well-planned, thought-out, and executed project.
- After seeing the improvement in the current collection of CdTe cells, the impact of the project is obvious. Nevertheless, the best result on the poster is almost 16% efficient, so its advancement to 20% requires further device optimization. Even so, the wider impact on the community of the understanding of the processes that passivate the grain boundaries and improve the bulk material is huge. This project is a good example of SunShot doing basic science in collaboration with national facilities to produce outstanding science.

- The funding for the project is also reasonable for the goals of the program. The overhead of sample preparation and analysis using relatively low throughput vacuum-based techniques requires a certain level of funding to be viable.
- The approach of fundamental material understanding in relation to the modelling and analysis performed here is completely correct. There is a clear relationship between the grain boundary recombination mechanisms (and mitigating them) and the subsequent improvement of device performance. There have also been strong publications from the project.
- Through a combination of spectroscopic techniques, the team has identified some very interesting behavior, along with the fundamental structure of grain boundaries in CdTe. These insights have the potential to redefine some of the way we look at this particular material system, and may lead to substantial performance improvement. Unfortunately, this is primarily speculation based on the results to date.
- If CdCl<sub>2</sub> treatment creates p-n junctions at the grain boundaries, why does the SEM-EBIC data show that the CdCl<sub>2</sub> treatment is responsible for improving photoactivity at the CdTe/cadmium selenide interface? How are these claims reconciled? P-n-p hypothesis seems to be based on density functional theory, but does any experimental evidence support inversion at the grain boundaries? It is unclear how the insights from TEM/SEM studies will be translated into performance improvements in CdTe PV. Little is said about the mechanism of copper treatment.

## PROJECT: 24618 NATIONAL RENEWABLE ENERGY LABORATORY

*High Temperature, Roll-to-Roll CdTe Superstrate Devices Using Flexible Glass*

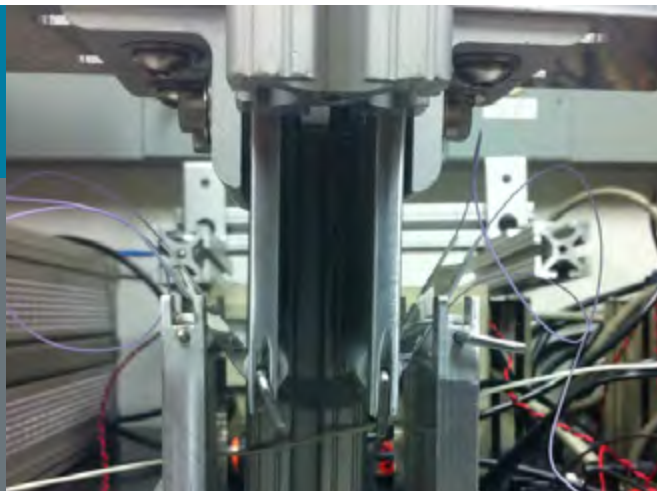

**FUNDING INFORMATION** \$1.5M | Foundational Program to Advance Cell Efficiency 1 | 09/2011–11/2014

### Project Description

The National Renewable Energy Laboratory (NREL), Corning, Inc., and the Colorado School of Mines are developing highly efficient cadmium telluride (CdTe) devices on flexible glass superstrates using high-temperature roll-to-roll processing. This approach combines the high deposition rates that are available in the existing CdTe manufacturing technologies with the throughput and capital equipment cost reductions offered by roll-to-roll processing and the balance-of-system savings enabled by flexible photovoltaics (PVs). The processing techniques explored here have the potential for efficiencies up to 18% and module costs below \$0.50/watt (W).

### Individual Reviewer Comments

- This project provides a technology demonstration of high-temperature-grown flex substrate CdTe PV. Given its ability to leverage established infrastructure and processes at NREL, the project was executed efficiently. The study of the flexibility of high temperature and transparent conductive oxides may find application in other industries or technologies. Having funded three postdoctoral students, it provides a good educational impact.
- All aspects for successful development are systematically considered in the project. Significant progress has already been achieved and the project seems to be well on track. A roadmap exists that enables the transfer of the results to industry. This project can already be considered very successful in view of the relatively low funding that was necessary to enable this development.
- This project is a good example of integrating basic research and development at a national laboratory (or

university), trying a new idea that can have a market impact, and deploying it into a pipeline where companies can engineer and re-engineer the process. A project that can propose a cost reduction of more than \$0.3/W is very much relevant to the Foundational Program to Advance Cell Efficiency program. Additionally, the results are promising, and if they are complemented with an understanding of what the new processing/growth-parameter space (a glass that can withstand 600°C) can buy, it could have a tremendous impact.

- The possibility of producing flexible solar modules is a unique selling point for thin-film PV. The project provides a comprehensive and well-balanced approach to develop and improve such a technology based on CdTe absorber material. The use of thin, flexible glass provides a good compromise between full flexibility and the established production processes on rigid glass.
- The questionable point is how inexpensive the flexible glass will have to be in order to achieve \$0.30/W cost reductions. A holistic cost model may be challenged to conclude an upside to cost—specialty glasses and sputtered transparent conducting oxides are cost adders, the roll-to-roll processing advantage is unknown, and an integrated module may still require glass as a support element. A successful product derived from this product would cater to a specialized market of flex PV. The baseline efficiency of the process is low compared to today's CdTe record efficiency; this eases the demonstration of the transition to flexible glass, but reduces relevance. The fundamental technical problem is not very disruptive. Assuming that one overcomes the technical challenge of handling flexible glass, an established process can be utilized.

## PROJECT: 24619 NATIONAL RENEWABLE ENERGY LABORATORY

*Accelerating CPV Efficiencies to Create a Sustainable Terrawatt Platform*

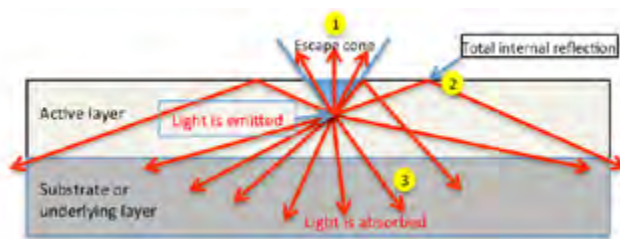

**FUNDING INFORMATION** \$3.5M | Foundational Program to Advance Cell Efficiency 1 | 09/2011–09/2014

### Project Description

A partnership between the National Renewable Energy Laboratory (NREL), Spectrolab, and the University of California, Berkeley is working to reduce the cost of concentrating photovoltaics (CPV) modules by increasing the CPV cell efficiency. This project team aims to increase cell efficiencies to 48% by inserting selective reflectors between the junctions of the multi-junction solar cells, thereby increasing the photovoltage. The work will strive to define the fundamental physics in parallel with implementing the concept.

### Individual Reviewer Comments

- This project has the potential to significantly increase the efficiency of III-V multi-junction cells, principally by addressing the significant issue of voltage enhancement through optical design. Current enhancement is no longer a possibility for most high-quality III-V solar cells, so improving the operating voltage represents the best chance to improve upon current state-of-the-art technology for a fixed number of junctions.
- This project has delivered impressive results with record-level efficiencies for dual junction cells at 1 sun. The potential to reach the project's stated aim of 48% seems promising. By doing so, and ensuring the costs associated with the optical design are carefully managed, the project will contribute to the U.S. Department of Energy's goals of increasing the efficiency, thus reducing the cost and balance of the systems requirement of CPV systems. The technology could also find application at the one-sun level, and is generally appropriate to all solar cells of the type that is based on semiconductor junctions.
- Approaching the thermo limit based on an understanding of fundamental physics is essential to the progress of solar cell development. This project provides cutting-edge approaches to this problem by understanding the limits and then applying that knowledge to improved cell performance.
- A strength of the program is that it focuses on both the theoretical modeling as well as practical demonstration/validation. Recent results demonstrate good progress. It would be interesting to extend the modeling process of this program to include real-world spectral and intensity situations. This might provide insights into the practical limitations, and/or spark new concepts for demonstration/validation.
- The project is an example of good fundamental work, which can be easily transferred without reaching world record efficiencies first. This project aims to improve the performance of multi-junction cells utilizing photo-recycling and concepts demonstrated in single-junctions (but not multi-junctions). The partners that assembled for this program are appropriate and provide the correct capabilities for its success.
- It would be useful for the community to also find out why this technology and design change works—something which is not clear at the moment (and is, perhaps, not a goal of the project). It would also be useful to have an explanation for how this project will be adapted to multi-junction cells.



## PROJECT: 24620 NATIONAL RENEWABLE ENERGY LABORATORY

*Enabling the CIGS Thin-Film PV Technology to Meet the DOE Goal of \$0.50/W Module Price*

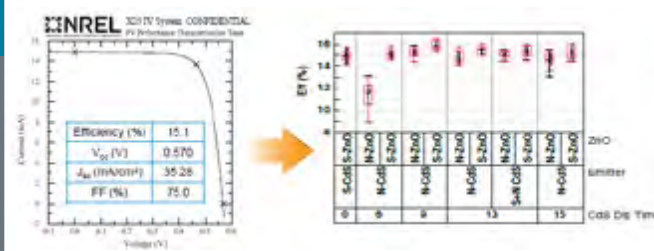

**FUNDING INFORMATION** \$6.2M | Foundational Program to Advance Cell Efficiency 1 | 09/2011–11/2014

### Project Description

This effort is providing near- and mid-term research to advance thin-film competitiveness via improved module performance and reliability of thin-film photovoltaic technologies. The project is enhancing the buffer and transparent conducting oxide layers and broadening the approach to processing copper indium gallium diselenide (CIGS) cells. Successful completion of this project would include demonstration by the industry partners of a greater than 16% efficient commercial module and a \$0.23/watt reduction in the cost of module manufacturing through efficiency improvements.

### Individual Reviewer Comments

- The project deals with some key challenges in CIGS technology, especially in collaboration with an industrial partner. The different efforts that were undertaken have been proven to be very successful. The scientific spectrum of the participants covering a wide range of methods and expertise is also impressive. The project money is very well spent.
- The stated objectives of high-efficiency cells, which is fundamentally in harmony with the scope of the Foundational Program to Advance Cell Efficiency (FPACE), all seem to overlap with the Annual Operating Plan, while the reported progress mostly focuses on the industry transfer activities.
- The program will make progress toward higher efficiency, given the substantially higher funding amount that the Annual Operating Plan provided. In the end, it may be challenging to provide details of its impact on cell efficiency. There is immediate and tangible benefit to the participating industry member. The activities of the project are very appropriate for a national laboratory to support—this aspect of the work will not lead to higher record cell efficiency or lower cost, but rather, to potentially more viable commercial players.
- Promising results on the gap tuning and widening with silver have been demonstrated. It would be interesting to understand the limitations of this approach, considering that the kinetics of silver can fundamentally affect the overall device performance. If, for example, the silver-rich phase diffuses towards the back of the device, it defeats the purpose of widening the gap.
- It is questionable how many of the tasks that are engineering optimizations should be led by a national laboratory and universities. They are, of course, valuable, but may be under a different framework. The funding level is in line with the aforementioned engineering work, which should probably be picked up in good part by a company's research and development.
- The project strategy is not clear. Additionally, this project looks into a lot of incremental gains based on the modification of the absorber, buffer layer, and emitter. Its main strength is the transfer of knowledge to industry. The project's relevance to the FPACE program is unclear. The hunt for efficiency is there, but the foundational part of FPACE is lacking. It looks like many different topics and approaches put together and tried on different samples, yet with no cohesion among them.
- The transfer activities are solving adoption problems, which are very common development activities for private enterprises. Consequently, much of the progress report focuses on the troubleshooting of the commercial processes, which provides little scientific insight or transferable learning. Other arrangements between the national laboratory and industry partners may be more appropriate to support such an activity.

## PROJECT: 25774 NATIONAL RENEWABLE ENERGY LABORATORY

### Cell and Module Performance

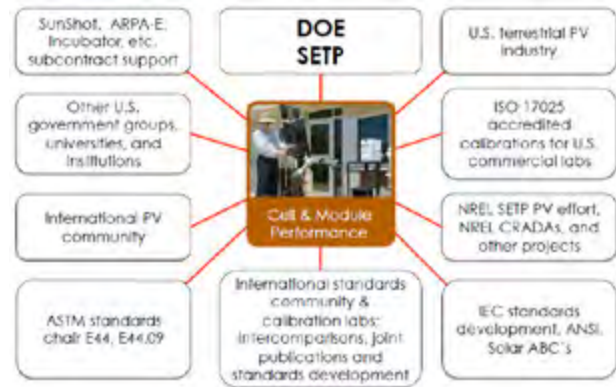

**FUNDING INFORMATION** \$8.1M | National Laboratory Research and Development | 10/2012–09/2015

### Project Description

This agreement supports the independent evaluation of cell and module contract deliverables, providing the United States photovoltaic (PV) industry with accurate and independent efficiency measurements and calibrations for all PV technologies and material systems. This partnership allows the U.S. Department of Energy Solar Energy Technologies Office to fairly evaluate atypical cells in cases when the data are impacted by artifacts such as metastability, spurious photocurrents, bias rate, nonlinearity, and other issues, such as contacting and area definitions. The National Renewable Energy Laboratory (NREL) team supports commercial testing and module qualification labs by providing required ISO 17025-accredited calibrations. The team also supports domestic and international PV cell and module standards development.

### Individual Reviewer Comments

- This project is like no other in the SunShot Initiative. Delivery of independent, high accuracy, and, of course, high speed to match the demands of cutting-edge research, PV calibration data is challenging and requires significant effort. Therefore, the project's relevance to the SunShot program is high, as many of the researcher's measurements can be independently verified. This is important to maintaining the trust in both scientific and commercial developments. It is very much the "go-to" center for PV cell calibration in the United States, and a critical resource to allow research and industry to accurately measure performance.
- This is an excellent group, providing a critical service to the field of PV. The price tag seems high, but there is no question that this group is the "gold standard" of PV certification. Additionally, the volume of work is very high and appears to yield a cost-effective approach.

- The historical uncertainty in determining the efficiency of solar devices is also being tackled in the project, with a significant list of publications so far.
- Without the services of the NREL calibration laboratory, many of the current accepted truths about device efficiency would be challenged more frequently, and the overall standard of measurement quality and accuracy would most likely lower so high an impact.
- The funding appears to be high in simple dollar terms, but the breadth of the program's impact across all activities in SunShot should not be underestimated. Aside from this, the cost of carrying out high-accuracy measurements on solar devices, ranging from small concentrated photovoltaic (CPV) cells to large-area flat plate modules, with all sorts of differing requirements should not be underestimated. A simple cost of a device that was measured (total cost of program × proportion of time elapsed in project ÷ number of devices or modules calibrated so far) indicated a cost of around \$6,700 per device. This compares favorably with the cost of calibration at other similar calibration laboratories.
- The approach of the project is reasonable. It seems that NREL still needs to cross-calibrate its own procedures with other laboratories around the world, thereby maintaining the quality (as well as delivery timescales) expected of it. However, the Primary Investigator's (PI) robust defense of the program suggested that many hundreds of cells or modules are calibrated on a monthly basis. Even so, this does not seem correct. The PI also takes a fairly unilateral approach to defining the correct measurement metrics in the case of CPV cell characterization. He may well be correct, but it is important to make sure that the entire metrology community is taken with him.
- The drive for reducing uncertainty in measurements was not clear.

## PROJECT: 25775 NATIONAL RENEWABLE ENERGY LABORATORY

### *High Efficiency III-V Multi-junction Solar Cells*

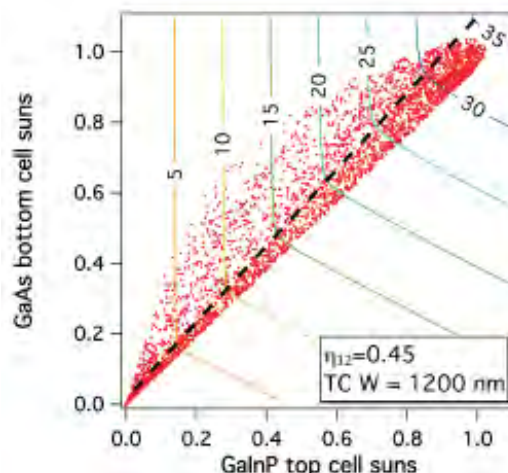

**FUNDING INFORMATION** \$6.9M | National Laboratory Research and Development | 10/2012–09/2015

### Project Description

This agreement integrates 3 parallel thrusts to create a 48% efficient quad-junction solar cell. First, process optimization will reduce electrically-active defects and create a conductive buffer to the fourth junction. Second, degradation rates and the radiative interaction between junctions will be analyzed and quantified. Third, the fourth junction will be optimized for efficiency.

### Individual Reviewer Comments

- This is well structured, technically well performed research and development on III-V cells for concentrated photovoltaic (CPV) application. CPV offers very high efficiencies; therefore, provided that sufficiently high cell efficiency and low cost are met, CPV can significantly outperform other PV technologies in areas of high direct normal irradiance and ambient temperature.
- The approach of fundamental materials understanding with respect to the growth of metamorphic buffers and threading dislocation density formation limitation forms a critical cornerstone to the development of this technology. The authors should be commended for their efforts in this area. The authors also alluded to their next step, which will be reducing the thickness (and increasing the growth rate) of the metamorphic graded buffers; this is critical to keeping the costs under control for a real product. The active layers of a III-V multi-junction cell can be comparatively thin when compared to the required buffer thicknesses; thus, the buffers can form a significant part of the cost.
- The group is well published, but this is a large amount of funding. The expected value and the need for continued public laboratory work in this area is concerning. The goal of this effort is to push efficiency from 42% to 48%. Already last fall, industry (Soitec) developed a 45% cell. The reviewer is skeptical of the value and ever-increasing efforts to make small improvements. The cost effectiveness is really tied into issues related to the manufacturing and design of cells, along with the manufacturing of modules trackers.
- The funding for the project seems high, but given the national laboratory status of the National Renewable Energy Laboratory (NREL) and the high overhead associated with metalorganic vapor phase epitaxy research, it is not too unreasonable.
- The quad-junction cell approach is being followed to increase record multifunction efficiencies to 48%. Careful materials science is being done to quantify and control threading dislocations in the fourth cell. A 0.7eV cell has been demonstrated with high quantum efficiency. The work is impressive, but not at the edge of groundbreaking. Given the exceedingly large budget of this program, it is reasonable to ask if this can be more effectively and inexpensively accomplished by other groups.
- Issues of temperature sensitivity and heat flux design are also present. An analysis is needed to show that this change of a few percentages will yield impact on the levelized cost of energy.
- If the authors are successful in achieving 48% conversion efficiency—especially with a much reduced spectral dependence through high luminescent coupling efficiency—then the impact will deserve a very high rating, yet it would seem that many commercial players are already doing exactly the same type of research.
- It seems as though there are three (III-V) NREL projects that are all extremely similar and would probably be better just as one project.

## PROJECT: 25776 NATIONAL RENEWABLE ENERGY LABORATORY

### *Multifunctional Transparent Conducting Oxides*

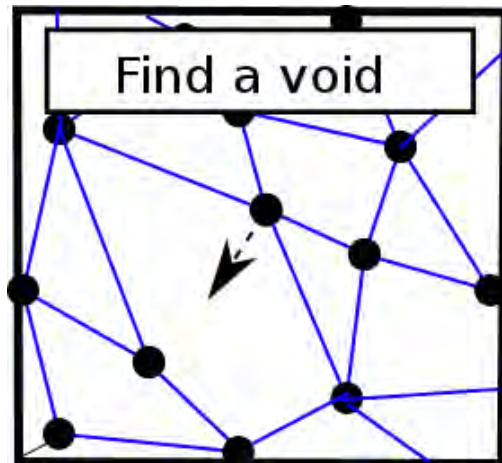

**FUNDING INFORMATION** \$1.5M | National Laboratory Research and Development | 10/2012–09/2015

### Project Description

This agreement pursues the development of promising transparent conducting oxides (TCO) for use in photovoltaic (PV) cells. The first goal is to demonstrate earth-abundant TCOs using industrially-compatible processing conditions with material parameters comparable to TCOs commonly used today. The second goal is to model and demonstrate the deposition of amorphous TCOs with tunable material properties that are flexible and/or cost effective. By furthering basic theory, demonstrating new materials, and optimizing processing, improved contacts can be created for multiple PV technologies.

### Individual Reviewer Comments

- This work continues the efforts of the group to improve the cost effectiveness and performance of metal oxides for contacts in PV. The project's strengths include a breadth of processes and material sets. Work seems to be substantive, and the project team features well-known researchers in the field. TCOs are important for PV, yet there are no explicit goals that are tied to the issues of importance for PV. It is hard to believe that TCOs are a price driver for anticipated improvements in first-generation PV modules. The project needs to tie this into the type of PV that needs this.
- The relevance of the project is moderate, given its multiple applications of materials. Its impact depends on finding cheap, easy, stable materials with manageable tools and processes. Thus far, the results are interesting, but not game changing.
- The project's approaches are multifold, varied, and leveraging. However, there is no information on future plans or approaches for the project. The documents that were provided do not indicate how significant strides will be made to improve the quality from past work. No results from the current program (nor its start and end dates) are provided.
- There seems to be a disconnect between the claim of producing low-cost and low-temperature work on indium-based materials, which are discussed in the white paper, but not mentioned on the project's poster.
- It would be valuable to place this basic material research and development in the context of very large industrial needs for these materials in the display industry.
- The PI states that "better results will come from trying harder" and improving process control. This leaves the impression of an incremental approach. The silver nanowire mesh is one approach that shows some promise. It is an innovative approach; however, it is still too early and difficult to see how the full promise of this effort will be realized.
- The funding of \$1.4 million over 3 years is relatively low. One of the project's weaknesses is its lack of breakthrough concepts. It is unclear where work on p-type interlayers is and whether or not hybrid work is new or unique.

## PROJECT: 25777 NATIONAL RENEWABLE ENERGY LABORATORY

*Overcoming Spatial, Energy, and Temporal Limits in Characterization of the Electrical, Optical, and Structural Properties of PV Materials*

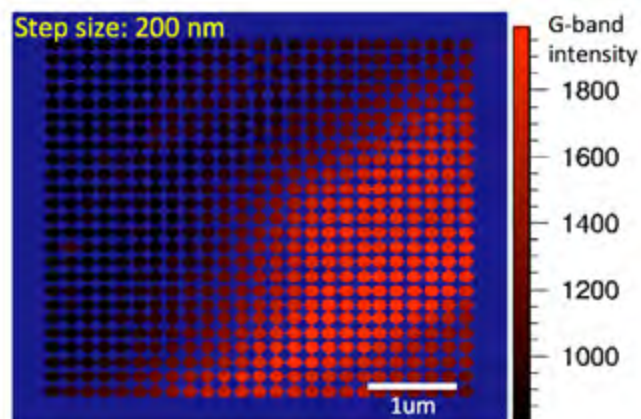

**FUNDING INFORMATION** \$3.5M | National Laboratory Research and Development | 10/2012–09/2015

### Project Description

This agreement pushes the limits of measurement techniques that are useful for photovoltaic (PV) materials. The focus is on two electrical techniques, admittance spectroscopy/deep-level transient spectroscopy (AS/DLTS) and scanning capacitance microscopy, as well as two optical techniques, two-photon time resolved photoluminescence and tip-enhanced Raman scattering. Developing these advanced measurement techniques and capabilities will further the knowledge of how material structure impacts PV device performance.

### Individual Reviewer Comments

- The device development effort is well done, but it is strongly suggested that the development be coupled with hypothesis-driven investigations that call for the information.
- The project's approaches are unique and potentially very leveraging. Its strengths include a variety and utility of tools under development, several of which are operational, or nearly so. The project's relevance is high, as multi-epitaxial thin films are limited by grain, and grain boundary and interface effects are very difficult to segregate at required dimensions. Additionally, the impact is high if and when tools are operational.
- The project is based on a number of assumptions, including the assumptions that efficiency increases are the key to module price goals and that limitations in

high-resolution optical and electrical techniques are the key obstacle.

- The amount of funding is moderate, given the number of tools that are being developed (\$3.6 million over 3 years). A large suite of characterization tools are developed for examining defects and other material properties of thin-film PV materials. It is unclear how this group of projects and tools come together to solve problems that ultimately result in higher PV performance. This connection is missing in the descriptions.
- One of the project's weaknesses includes a potential for "solutions looking for leveraging problems." Only time will tell.

## PROJECT: 25778 NATIONAL RENEWABLE ENERGY LABORATORY

*CdTe Technology: Understanding How Defects in CdTe Limit the Performance of Solar Cells*

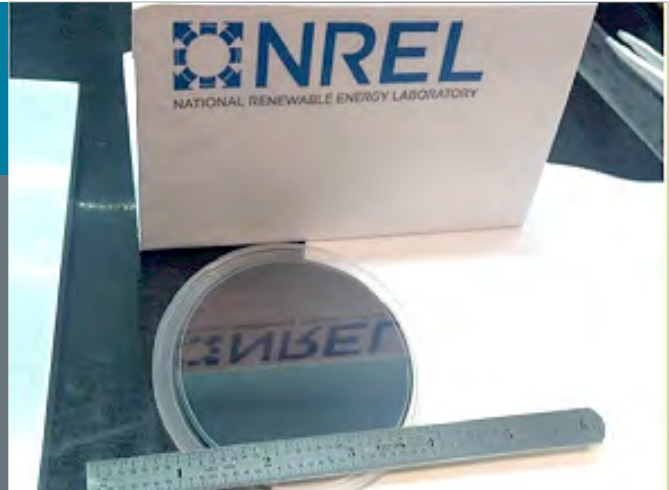

**FUNDING INFORMATION** \$10.0M | National Laboratory Research and Development | 10/2012–09/2015

### Project Description

This project works to increase the open-circuit voltage and fill factor of cadmium telluride (CdTe) solar cells. The approach is to examine single crystals that are grown by molecular beam epitaxy and polycrystalline CdTe films with different grain sizes to understand and increase carrier concentration and lifetime. Stoichiometry and doping are varied to influence lifetime and recombination by the grain boundary type that is being studied.

### Individual Reviewer Comments

- The project is the technological backbone of the development of CdTe solar module technology. It investigates polycrystalline films grown by closed-space sublimation and films grown by molecular beam epitaxy in parallel. The project is very focused on attacking the most challenging aspects of the CdTe material system; namely, doping and lifetime to demonstrate high  $V_{oc}$ . Therefore, its relevance is high, given the United States' position in CdTe photovoltaic manufacturing. Its strengths include a useful blend of theory, modeling, experimental laboratory work, and measurements on both materials and devices.
- The challenges for improving CdTe solar modules have been identified very clearly. The bulk of the work on impurities, doping, and grain boundaries in industrially relevant CdTe absorbers is highly relevant. It remains to be seen whether or not the approach of

obtaining relevant information from molecular beam epitaxy-grown films is successful.

- The three-pronged approach (single crystal, large grain, polycrystalline) seems to be reasonable, sound, and holistic; it should help transfer learning and derive fundamentally correct conclusions. However, this project is neither unique nor a quantum leap. Additionally, the collaboration of the project with other projects dealing with a similar topic remains to be discussed.
- Its impact depends on long-term transferability to high-volume manufacturing (HVM) methods (e.g., do “manufacturable methods” translate to scalable, low-cost methods). In view of the need for a science-based technology platform for CdTe solar module technology, the spending is appropriate because running such a platform is expensive. However, others felt that a funding level of \$10 million for 3 years was expensive.
- A weakness of the project is its uncertainty of transferability to HVM. It is unclear if the principles or specific methods are applicable to HVM factories.
- While the approach mentions to “transfer” the learning, there seems to be no effort or emphasis to improve px cell efficiency in the traditional process flow.
- The model system approach requires capability development and substantial process optimization in its own right—much of which may not be of sustainable usefulness.

## PROJECT: 25779 NATIONAL RENEWABLE ENERGY LABORATORY

### *CIGS Thin Film Technology: Overcoming Barriers to Increase Efficiencies and Reduce Cost*

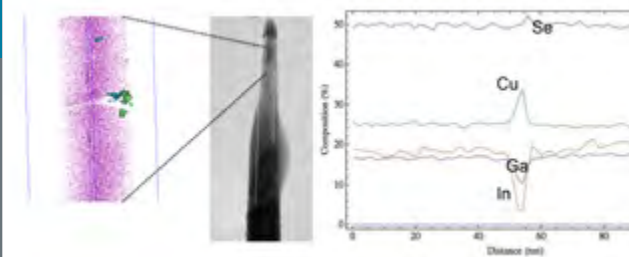

**FUNDING INFORMATION** \$9.0M | National Laboratory Research and Development | 10/2012–09/2015

### Project Description

The research of this project addresses the scientific issues that need to be overcome for copper indium gallium selenide (CIGS) solar cells to be successful in volume manufacturing. To increase cell voltage and efficiency, work is being done on higher bandgap devices (1.15 eV to 1.4 eV) than typically used. To increase the current without compromising junction quality or incurring metastable behavior, cadmium selenide (CdS) is being replaced by more transparent ZnOS. Additionally, absorber processing is being simplified by using a two-step approach where metal precursors are prepared by evaporation and selenized rapidly in selenium vapor at high temperature.

### Individual Reviewer Comments

- A successful outcome will lead to a new record in efficiency for CIGS technologies, and potentially improve prospects for high bandgap energy CIGS for tandem cell applications. The strengths of this effort include a potential for direct transfer to the United States photovoltaic (PV) industry.
- NREL has a long history of making record CIGS efficiencies. Talent and infrastructure are in place to execute state-of-the-art research and development. Additionally, this project covers the key issues for providing the scientific and technological base for a highly efficient CIGS module technology. The awardees have proven in the past that they lead the way in the entire field and that most record efficiencies in the past have been produced in this laboratory.
- Especially acknowledgeable are recent results that are somewhat outside of the standard approach (like high-bandgap materials and non-CdS buffer layers). The project also enables the ability to follow very quickly new and surprising developments in the field (like alkali treatments).
- The program is very well balanced between technology development and fundamental characterization. The funding is also appropriate, considering that it is operational in running the world-leading laboratory that is devoted to this technology. Its relevance, however, is moderate, given the multiple second-tier CIGS PV companies in the United States.
- While characterization is being performed, neither the program outline nor its presented results make a case that there is a structured approach in place to address its specific shortcoming. Much of the work is considered to be Edisonian. Corporate R&D has caught up with this work over the years and currently holds the world record. Further investments in CIGS world-record cells may need to be carefully considered, though more progress will be difficult to achieve (due to cost expenses) and the perceived commercial benefit will be very limited. The same resources could be focused toward more disruptive ideas.
- The impact of the project depends on its innovation and uniqueness (e.g., if it catches up to Solar Frontier) and on transfer to high-volume manufacturers (e.g., SIVA and Stion). Its approaches are good, but neither game changing nor unique.
- The project's weaknesses include a lack of unique innovation or fundamentally new ideas. Additionally, CIGS lacks a commercial demonstration of being a high-volume, low-cost, and manufacturable choice for thin films. However, private investments have been steady over the years.
- The focus in Task 3 toward manufacturable processes appears to be out of place for what the program should be focusing on: higher efficiency.

## PROJECT: 25780 NATIONAL RENEWABLE ENERGY LABORATORY

### *An Integrated Approach to Organic Photovoltaics*

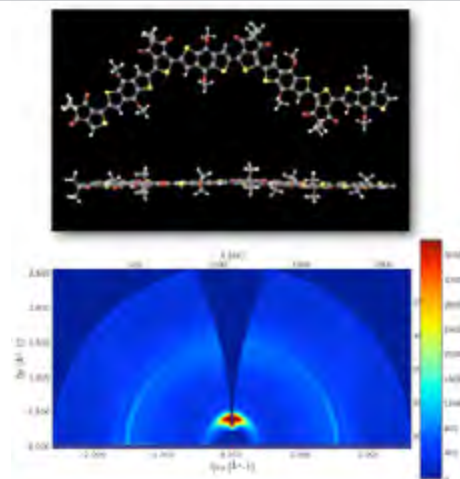

**FUNDING INFORMATION** \$4.4M | National Laboratory Research and Development | 10/2012–09/2015

### Project Description

Organic Photovoltaics (OPVs) could become a low-cost technology amenable to high-throughput fabrication techniques. However, OPVs need to overcome short device lifetimes and low efficiencies. This project integrates theory, computation, and characterization to discover and develop new materials for OPV that advance efficiency and improve lifetime. There are three integrated research tasks: (1) the design and development of new absorber materials through combinatorial computational methods coupled to their direct synthesis, characterization, and device optimization; (2) the development of charge-selective hole and electron contacts that optimize interface properties, performance, and stability for new active layer materials; and (3) the investigation of device and materials degradation mechanisms and mitigation strategies to extend device lifetime.

### Individual Reviewer Comments

- The project's strengths include its development of its portfolio of materials and structure/properties relationships, and its investigation of fundamental degradation mechanisms (e.g., the impact of inverted cell structures). The approaches and objectives to achieve these goals are well defined, effective, and efficient. The value of in silico could be high, and the team's initial work supports this.
- The project is relevant if it can accurately predict material characteristics and device performance. It will be very relevant if it can accurately predict performance boundaries (e.g., likely limits/types of OPV technology).
- The funding amount seems to be the right size for the effort and its reported results. Its funding of \$4.2 million over 3 years for 3 people seems to be well worth the effort if it can make accurate predictions.
- This project has the goal of understanding and developing materials for long-lived, efficient OPV. The approach is primarily computation-based, looking for the best polymer materials combinations leading to both high efficiency and long life. The calculation of frontier orbitals is only a small part of the solution—morphology and other aspects must also be included, which are beyond the scope of this approach. Hence, the results thus far do not “raise the bar” on our understanding of processes or materials. The long lifetime claim is not supported in the data shown, and the efficiencies are very low compared to state-of-the-art technologies. Given the size of the program, the impact is not large.
- It is unclear if the project team understands the key parameters mechanistically well enough to predict them. It is unclear, but the project is an important effort nonetheless.
- The project's impact is limited, given OPV's likely impact on major power markets.



## PROJECT: 25781 NATIONAL RENEWABLE ENERGY LABORATORY

### *Low-cost, High-efficiency, One-sun Hydride Vapor Phase Epitaxy III-V Solar Cells*

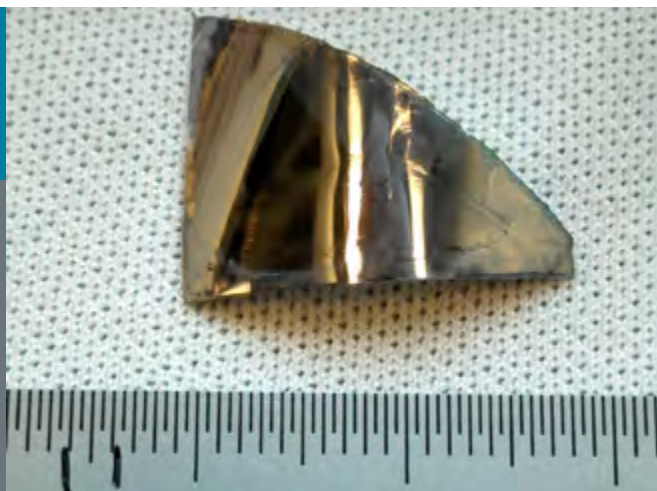

**FUNDING INFORMATION** \$1.5M | National Laboratory Research and Development | 10/2012–09/2015

### Project Description

This project aims to develop a new III-V, one-sun solar cell concept that has the potential to outperform silicon modules in both efficiency and cost. This will be achieved through the growth of III-V materials by hydride vapor phase epitaxy (HVPE) in a revolutionary, in-line reactor, rather than by expensive metallorganic vapor phase epitaxy (MOVPE) in a traditional batch reactor. The many advantages of HVPE include much lower precursor costs (pure metals rather than organometallic engineered molecules, representing a 5–10 times savings), higher deposition rates (1–5 micrometers/minute or 10–50 times faster), significantly increased material utilization (much lower arsine overpressure), and inherent cost savings due to atmospheric-pressure, in-line growth. This technology is expected to reach grid parity cost points, along with favorable balance-of-system efficiencies, by significantly lowering the cost of III-V material growth and by applying a simple, fast layer-transfer process to reuse an epitaxial template wafer.

### Individual Reviewer Comments

- The replacement of MOVPE with a lower cost high-throughput growth technology is essential to the success of III-V solar cell technology. The “reintroduction” of hydride vapor phase epitaxy is a potentially excellent approach to this problem.
- The development and build of a prototype cluster tool for the growth of materials with very promising initial results gives this project the opportunity to make a real impact on the efficiency and cost goals of the SunShot Initiative. The forecasted \$0.7/watt is slightly higher than the stated goal, but the approximately 30% higher cell efficiency compared to state-of-the-art silicon cells means that the balance-of-system costs would be appropriately reduced.
- This project addresses an important issue for concentrated photovoltaic technologies. The only reason it was scored low is that it appears that this effort needs to budget and plan for a follow-on study to yield the results.
- The project would stand alone well just as a HVPE development project. Additionally, the project is showing good initial progress, although, as is often the case, the performance of HVPE material is not as good as MOVPE. Nevertheless, it is a good start with a large potential impact if the project is successful. However, there is skepticism with the use of wafer spalling. This is a diversion, so the program should focus on the more important problem of improving the HVPE growth quality.
- The new HVPE tool has only been online for approximately 3 months, and, already, initial results are greater than 10% efficiency for a completely non-optimized cell structure with no antireflective coatings; this is very promising. The spalling technology—while not novel—is a very convincing way of producing reusable substrates.
- The project promises III-V cell efficiency, which is obtainable for one-sun devices at the right cost. This project has ambitious goals that require the development of (almost) new growth technology—while maintaining or not reducing material quality too far—and the other important factor of substrate reuse.

- No mention is made of the necessary reuse cycles and the required yield to account for the costs in the model. It should be noted that multiple reuses and a high yield are essential to keeping the net substrate cost contribution to a minimum. It is appreciated that the effort initially focused on the HVPE tool development and the initial samples for material quality analysis, but it would be good to see much more information about the spalling technique, such as yields, reuse cycles, impact on surface quality, spall depth control, and gauge R&R, and so on.
- The approach of ultra-high growth rate epitaxy for gallium arsenide 1J cells is sensible and, to some extent, already demonstrated by others in the field (e.g., Alta Devices). The ease with which GaAs lends itself to very high efficiency solar cells is, of course, a boon for the project.
- To ensure its future success, the project should also examine the spalling reuse and yield statistics; the real cost of cell production on the new tool; and fundamental device performance limiting factors, such as interface recombination at hetero- and homo-interfaces, optical design to maximize  $V_{oc}$ , and materials choice to maximize absorption. At this stage, the reviewer is not convinced that the radiative limit for GaAs cells will be achieved with HVPE. However, a 1x module at greater than 20% efficiency remains realistic and potentially low cost.

## PROJECT: 25782 NATIONAL RENEWABLE ENERGY LABORATORY

### *Next-generation Earth-abundant Thin Film CZTS Photovoltaics*

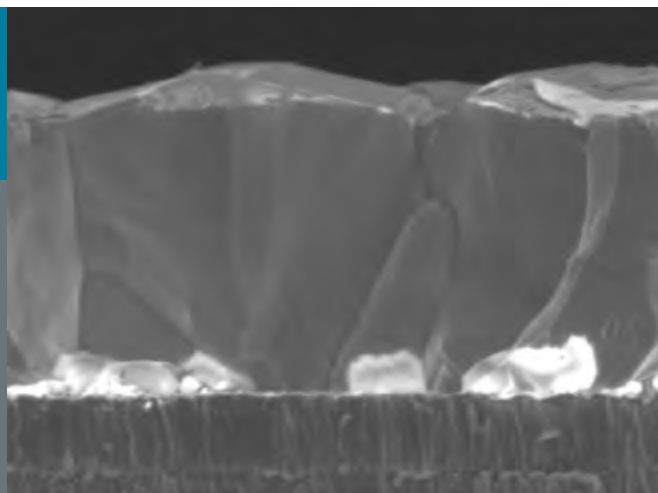

**FUNDING INFORMATION** \$6.9M | National Laboratory Research and Development | 10/2012–09/2015

### Project Description

Kesterites (e.g., “copper zinc tin sulfide [CZTS],”  $\text{Cu}_2\text{ZnSnSxSe}_{4-x}$  and related alloys) can contribute to SunShot goals by providing an earth-abundant, thin-film alternative to copper indium gallium selenide (CIGS) and cadmium telluride. However, a substantial increase in kesterite performance is needed, requiring a greater fundamental understanding of kesterite materials. CZTS work at the National Renewable Energy Laboratory is aimed toward developing this basic understanding of defects and interfaces in the kesterite materials system and how to control them during film processing. Defects and interfaces are studied in a variety of systems, ranging from theoretical models to simplified experimental samples and geometries, and to the best device quality polycrystalline thin films.

### Individual Reviewer Comments

- The project envisages the development of high-efficiency CZTS devices in combination with a sound understanding of the limiting factors. The project is very well balanced between technological development and fundamental understanding. Additionally, the project has a clear road map in terms of its milestones. Its tasks are very well defined. The activities make very good use of scientific expertise that has been developed in the context of other materials, especially CIGS, but also understands that CZTS bears more specific challenges.
- Its strengths include a strong technical team and good experimental cell progress that supports theoretical and analytical work. The project’s relevance is high, given that CIGS photovoltaic (PV) is growing and the United States’ likely best shot at intercepting existing CIGS industry is with lower-cost, scalable kesterite technology. The funding is absolutely appropriate.
- The project targets to improve CZTS efficiency to 15%. This seems like a modest objective, but more importantly, the emphasis on creating a fundamental picture of the defect and interface properties is well chosen. A number of problems have been identified that need to be overcome in order to reach the envisaged milestones.
- The approach is well blended between modeling, analysis, and growth. The epitaxial model system approach may be premature for this technology, given that there is ample opportunity for empirical progress. The approach has a wide scope of integrated experimental and theoretical actions, and has made good specific progress (e.g., 9.8% CZTSe cells).
- The number of publications is impressive. Aside from the selected highlights, the poster, unfortunately, does not give broader insight into the various accomplishments. Some of the milestones and objectives appear overly optimistic; identifying “the killer defects” and eliminating them may pose a greater challenge than a program this size can hope to accomplish in its final year.
- If the program succeeds, it could have a tremendous positive impact on CZTS technology; that is, unless some fundamental limiting mechanism is identified.
- The project’s impact is moderate. The likely impact of its good technical team and technological progress is somewhat offset by a lack of vigorous kesterite PV commercialization activity that is currently underway in the United States.
- A weakness of the project is its lack of vigorous U.S. kesterite commercialization partners.

## PROJECT: 25783 NATIONAL RENEWABLE ENERGY LABORATORY

### *Next Generation Silicon Photovoltaics*

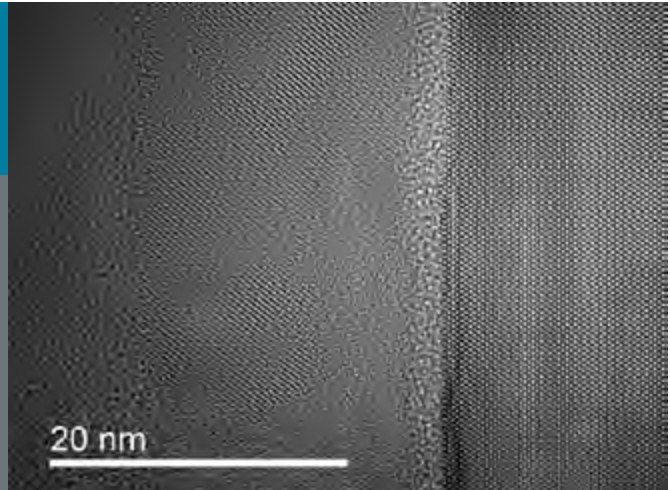

**FUNDING INFORMATION** \$8.6M | National Laboratory Research and Development | 10/2012–09/2015

### Project Description

This project is geared toward producing high-efficiency tandem solar cells based on silicon technology. There are two areas of focus: (1) developing techniques to achieve high-efficiency single-junction silicon solar cells through contact passivation; and (2) modeling and realization of novel III-V materials and processes for producing a 30% efficient silicon tandem solar cell. The production of a tandem silicon solar cell has the possibility of moving towards two junction efficiencies with lowered costs.

### Individual Reviewer Comments

- This project investigates a credible pathway toward record silicon cell performance using a method that conceivably can be scaled at low cost, and, hence, would achieve low-cost energy. A strength of the project is its focus on the development of a solid baseline silicon process of 22% efficiency without being distracted by the push for ultra-high efficiencies on single junctions.
- The project is structured into two deliverables: a National Renewable Laboratory (NREL)-established, high-efficiency sx baseline and an exploration of tandem cell architectures for cell efficiency at greater than 20%. It should be appreciated that the dominant technology in the world is silicon, and the ability to produce low-cost, high-efficiency manufacturable silicon photovoltaic is the primary objective for most, if not all, corporate research and development teams.
- Breaking the program into two tasks enables the focus that is required to develop the silicon baseline; this foundation will be leveraged many times. Secondly, it is good to see that the team has set a realistic goal for this

architecture, so that the team's focus can rightly shift to Task 2 and not get stuck in Task 1.

- NREL has strong competency in multi-junction solar cells. This project strength will enable the program team to “hit the ground running.” NREL does not have strong competency in silicon solar cell technology, just yet; therefore, the inclusion of some collaborative partners that bring this knowledge and experience to the program is useful.
- NREL has a group that is capable of cost modeling; hence, it would be useful to investigate the cost structure of this multi-junction on silicon approach to validate that the added process complexity is overcome by the improved energy production. It is common to assume that an efficiency benefit will pay for such complexity, but with a target of less than \$0.5/watt at 20% efficiency. Additionally, with the inclusion of some expensive materials and techniques, this assumption may not pencil out. At the end of the day, the focus needs to be on the cost of energy production, rather than efficiency. It would be worthwhile to integrate some modeling and/or experimentation of real-world performance.
- The introduction of a second junction has some impact on the cells' spectrum tolerance—hence, energy production in the morning and evening. It may also have some impact on the angle of acceptance. These are some examples of what is meant by energy versus efficiency. The second aspect is reliability. With any new architecture, it is critical to consider its reliability during the research phase. Fundamentally, it is important to know how these architectures will degrade in real-world conditions. The success of the overall program depends

on finding the correct practical materials for the top cell. This will not be an easy assignment; however, should the team be successful, it will provide a very relevant breakthrough in solar cell technology.

- The project's scope is too broad. There is not much leverage in selected tandem.
- The likelihood that an NREL-funded program can impact the course of the technology is rather limited. However, investing in a high-performing cell baseline at NREL is still a sound investment, assuming that this strategic decision is a building block for future technology developments (such as Task 2 activities).
- Task 2 activities are disruptive ideas with a great degree of uncertainty and high risk. The approach to using virtual engineering via density functional theory to identify suitable materials is applaudable; nonetheless, it must be appreciated that there is a very long rocky road ahead for developing new materials that are not only compatible, but also 20% efficient, to forming plausible tandem structures.

## PROJECT: 25784 NATIONAL RENEWABLE ENERGY LABORATORY

### *PV Partnering and Business Development Agreement*



**FUNDING INFORMATION** \$12.0M | National Laboratory Research and Development | 10/2012–09/2015

### Project Description

The primary goal of this agreement is to expand the National Renewable Energy Laboratory's (NREL's) high-impact, collaborative partnerships with industry and academia in activities that exploit complementary capabilities and support the SunShot goals. There are two distinct partnering modes: (1) non-proprietary partnering opportunities, which aim to publish the research outcomes in prominent journals, and (2) proprietary partnering opportunities, which aim to develop intellectual property that will increase the speed of product commercialization and expand the scale of photovoltaic deployment. Additional outreach activities focus on workforce development opportunities for graduate and postdoctoral students.

### Individual Reviewer Comments

- This seems like a valuable program; however, much of the money that is used for facilitating interactions must be funded through other means or allocations; this seems to be a backdoor pathway to funding certain activities.
- The approach seems to be a mixture of general (e.g., outreach) and specific (e.g., Massachusetts Institute of Technology and International Electrotechnical Commission) projects. It is unclear why specific projects are not directly competed with and funded through other channels (e.g., broadly-competed FOAs).
- The limited information that is provided does not allow one to see how the work is relevant or impactful. It also difficult to see what the approach is. It is unclear who pays the non-proprietary partnering opportunity (NPO) partners, what the funding level is for in-house work,

and what the in-house contributions are. The philosophy behind the proprietary partnering opportunities (PPO) is also unclear. Its goal appears to be completely self-serving.

- This project's structure should be rethought. The NPO effort is full of potential conflicts of interest and should be directly managed by U.S. Department of Energy headquarters. It is unclear why this work should not be competed within an a funding opportunity announcement. The PPO work should be funded out of NREL overhead. NREL is incentivized to do this as part of their fee structure, and DOE is paying it to do business development. The reviewer thinks this is inappropriate.
- Little information is provided regarding the large funding for an evaluation of the quality and impact of this project. Of course, collaboration with external partners is important, but aside from a few superficial examples, no details are provided.
- The work and management of this partnership program are good, but there is concern with it being a major funding conduit (the reviewer prefers clearly competed solicitations, or more clearly defined criteria for an "extra" funding of otherwise overlooked and/or delayed activities).

## PROJECT: 25785 NATIONAL RENEWABLE ENERGY LABORATORY

### *Rapid Development of Earth-abundant Thin Film Solar Cells Using Inverse Design*

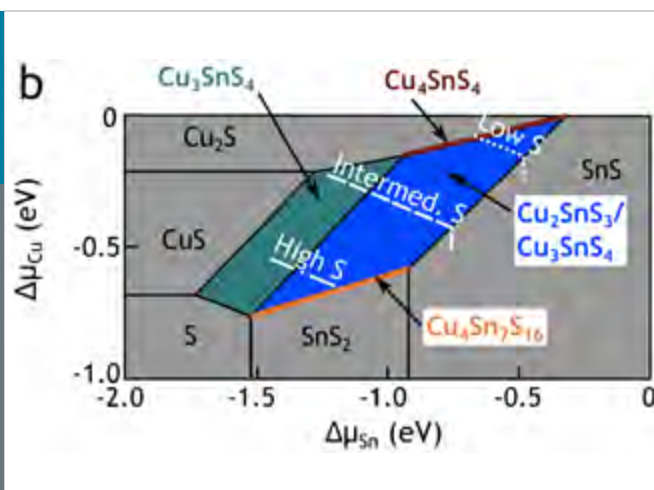

**FUNDING INFORMATION** \$1.5M | National Laboratory Research and Development | 10/2012–09/2015

### Project Description

In order to diversify the materials base for inorganic thin-film solar cells—which may allow for new technologies with reduced costs—an accelerated development technique is being pursued. The approach initially focuses on ternary copper sulfides and iteratively combines predictive first-principles theory and high-throughput experiments. Both individual materials and photovoltaic (PV) device prototypes will be developed using the high-throughput technique to accelerate the development process. The results of this project have the potential to drastically expand the materials options for PVs and produce new earth-abundant thin-film solar cells that are competitive with incumbent technologies.

### Individual Reviewer Comments

- This seed project—which has a strong team—uses fast calculations combined with experiments to evaluate new Cu-Sn-S, Cu-Sb-S, and (Sn,M)O materials for earth-abundant PV. The development of totally new thin-film absorbers is worthwhile in case of a big win. The “materials by design” approach is a good way to tackle otherwise overwhelmingly large parameter space. The combination of materials by inverse design and combi growth approaches can really accelerate the rate of development of earth-abundant thin-film solar cells.
- The combined theory and experimental effort in exploring new materials for PV absorbers is strongly relevant to the program goal. In the past two years, the team has made some progress in the simulation effort with some preliminary thin-film growth of new systems.
- The project’s extensive modeling results have guided its experimental effort to evaluate  $\text{Cu}_2\text{SnS}_3$  and  $\text{CuSbS}_2$

devices. The team succeeded in growing and characterizing these devices, which included showing some doping control in both. The selected materials met the baseline requirements for PV.

- A strength of this project’s approach is its ability to comb through numerous combinations and parameter spaces. However, there is a weakness that lies in there as well. Similar to any other computational approach, it is possible to overlook or dismiss seemingly promising candidates based on calculations that can be overestimating or underestimating certain properties. In this case, the selection of Cu-Sn-S and Cu-Sb-S seems a bit random, especially given the layered structure of the latter and the high hole concentration of the first one.
- A reviewer felt that the funding seemed a bit high for an intensive computational project, though another felt that it was reasonable for a three-person national laboratory effort.
- The poster and summary clearly presented all aspects of the team’s progress. There is no strong evidence that these new materials systems will significantly exceed the state-of-the-art PV performance. The abundance of tin and antimony is 0.00022% and 0.00002%, respectively, compared to gallium, at 0.0019%, indium, at 0.000016%, and selenium, at 0.000005%. Only the replacement of selenium is a significant improvement. It is unclear if it is possible to consider a candidate simply replacing selenium in CIGS cells, if using an earth-abundant element is a critical consideration for this work.
- No device results were shown for any of the materials (it is still too early).  $\text{Cu}_2\text{SnS}_3$  appears to be too highly doped to perform well in PV.

## PROJECT: 25786 NATIONAL RENEWABLE ENERGY LABORATORY

*NCPV Director's Initiative and PV Capital Reserve*



**FUNDING INFORMATION** \$5.2M | National Laboratory Research and Development | 10/2012–09/2015

### Project Description

The National Center for Photovoltaics (NCPV) Director's Initiative was established in fiscal year 2011 as a vehicle for funding small research and development projects, unplanned laboratory equipment purchases, and other PV-related initiatives at the discretion of the NCPV Director. The funds have been used to catalyze high-risk research by making modest enhancements to R&D capabilities through equipment purchases as well as providing seed money for strategic hires. The NCPV Director allocated capital expenditure funds (\$4.5 million) to support the greatest needs of NCPV.

### Individual Reviewer Comments

- The project's relevance is high, as certain high-strategic-value lab projects are not easily funded within other channels. In particular, this "project" seems to underscore the need for explicit capital tool refresh funding for NCPV. Its impact is high, given its targeted nature of investments.
- The approaches are sound; they include a mix of small specific expenditures (e.g., Hydride Vapor Phase Epitaxy components) and one-time strategic expenditures (e.g., rebuilding crystalline silicon PV capability and acquiring perovskite capability). The project's funding is reasonable for much-needed capital tool refresh.
- No poster was available to review and no rationale or process was described regarding the project's use of funding and the value that it has achieved. The information that was provided reads like a slush fund with no strategic planning. This harsh review reflects the materials that were provided.
- Based on the discussion, this is a critical activity that is underfunded and improperly structured. A capital fund should have a long-term plan and not be required to steal from the R&D funds. Close coordination with the National Renewable Energy Laboratory's real capital fund is essential and should not be dependent on ad hoc work. This is not a criticism of what is being funded, but rather, it is a criticism of the U.S. Department of Energy structure/process for providing the funds.
- It is entirely reasonable to provide the laboratory with a reserve to fill gaps where needed. These funds appear to be put to good use. However, this is not a good way to fund capital renewal, as it removes R&D funding to maintain and strengthen lab infrastructure. While this is very important, there ought to be a more effective way than using the current mechanism to acquire these funds.



## PROJECT: 25853 LAWRENCE LIVERMORE NATIONAL LABORATORY

### *Rational Design of Wide Bandgap Buffer Layers for High-Efficiency Thin-Film PV*

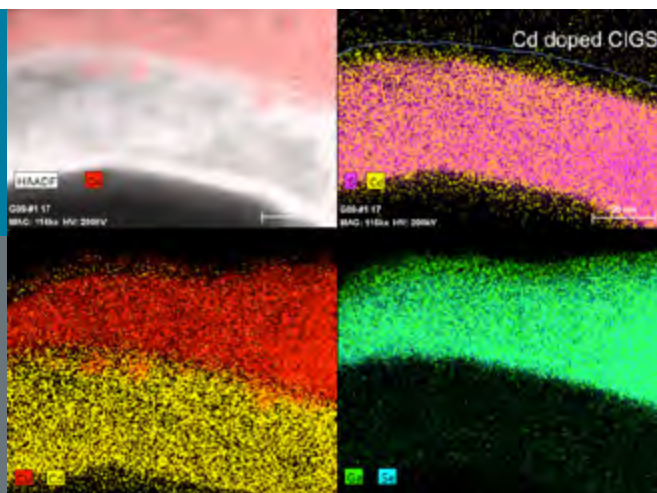

**FUNDING INFORMATION** \$0.31M | Bridging Research Interactions through Collaborative Development Grants in Energy | 11/2012–11/2015

### Project Description

Lawrence Livermore National Laboratory is working in collaboration with the University of Illinois at Urbana-Champaign and industry partners to provide a critical understanding of the role of bulk and interface defects in limiting the performance of buffer layer materials that are necessary for the fabrication of stable, high-efficiency thin-film photovoltaic (PV) devices. This project is innovative in its application of first-principles atomic scale modeling to the design of buffer layer materials for thin-film PV, as well as in coordinating complimentary state-of-the-art computational and experimental efforts to accelerate progress, which expands the breadth of expertise and resources being applied to PV system design.

### Individual Reviewer Comments

- This is a well-designed project that brings to industry unique national laboratory capabilities. The project has a good approach. A strength of this project is its approach of focusing on fundamentally understanding the present limitations of cadmium sulfide (CdS). Its focus on physical mechanisms, process interactions, and material properties provides detailed understanding that will underpin future work in this space. The project utilizes the characterization and process capabilities of the participants in order to develop this picture. This demonstrates that an appropriate set of partners or capabilities are involved in the project. The identification and characterization of oxygen, hydrogen, carbon and nitrogen-related defects is a good example.
- Understanding the nature of the defects in the buffer layer (for example CdS) in thin-film PV is critical to minimizing the absorption in the buffer layer. Through this study, the team will be able to identify the key mechanisms for absorption, and, thus, be able to guide future buffer design.
- Another strength of the project is in its use of modeling to identify likely replacement candidates, which speeds up the screening process. The program needs to pivot from the optimization of the current CdS buffer layer to focusing on the development of newer materials.
- The project budget is reasonable for a large team of nine members.
- There is no solar cell component (synthesis and testing) implemented in the program. Therefore, such a fundamental study will have difficulty correlating with cell performance enhancement. If such a correlation is missing, the defects that are identified by theory and transmission electron microscopy studies might not be the key ones for efficiency reduction. The ultimate goal is to enhance the PV efficiency by conducting a fundamental defects study. However, such a link is relatively weak in this program.

## PROJECT: 25859 SANDIA NATIONAL LABORATORIES

*Developing Spectroscopic Photoemission Electron Microscopy for Imaging Nanoscale Variations in the Chemical and Electronic Structure of Thin Film Materials*

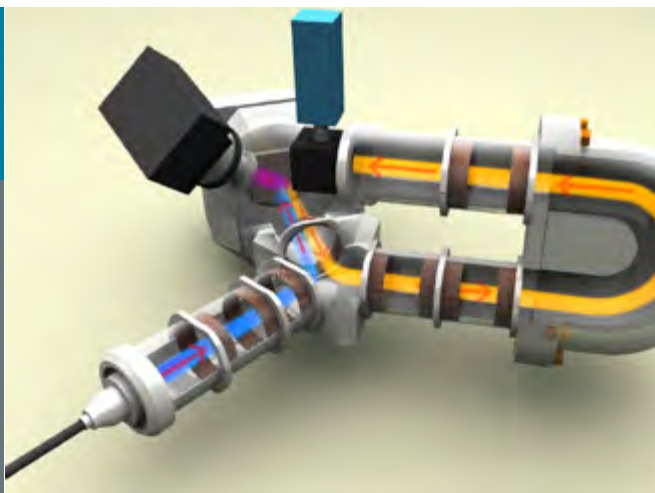

**FUNDING INFORMATION** \$0.3M | Bridging Research Interactions through Collaborative Development Grants in Energy | 11/2012–11/2015

### Project Description

Spectroscopic photoemission electron microscopy (spec-PEEM) enables real-time imaging of photovoltaic (PV) materials and devices with unprecedented nanoscale (5-10 nanometers) sensitivity to chemical and electronic properties. Current microscopes do not have sufficient or concurrent spatial, spectral, temporal or contrast capabilities to image these nanoscale properties.

### Individual Reviewer Comments

- The project is developing a powerful, promising PEEM and low- energy electron microscopy (LEEM) technique for imaging physical and electronic structure of polycrystalline films with sub 100-nm resolution. This has merit and could have a big impact on the understanding of various PV active layers. The project also features strong collaboration.
- The microstructure of the copper indium gallium selenide (CIGS) absorber material—especially at its surface, which later becomes the critical buffer/absorber interface—is of crucial importance for the final device property. The combination of structural and chemical data by combining LEEM and spec-PEEM is an original and promising approach. It is especially appreciated that the project combines such a fundamental scientific approach with film preparation methods that have industrial relevance. The preliminary results are promising and the project money is very well spent.
- Imaging the potential profile across grain boundaries in CIGS is a good start to developing and benchmarking the technique.
- The proof in the true utility of this technique will be to the extent that it identifies materials' properties that cannot be monitored by other techniques, and creates new insights in comparison to other techniques. Although it was shown that the results seem better correlated with  $V_{oc}$ , rather than LEEM, it is not clear that it will enable any breakthroughs.
- It is unclear what is really new about the technique, considering that PEEM/LEEM is already well known. The interpretation of intensity-voltage data seems preliminary. A modeling component would add confidence and help with technique development and acceptance.

## PROJECT: 25860 NATIONAL RENEWABLE ENERGY LABORATORY

### *Developing a Transparent Emitter Layer for CIGS Solar Cells through Synchrotron Investigations*

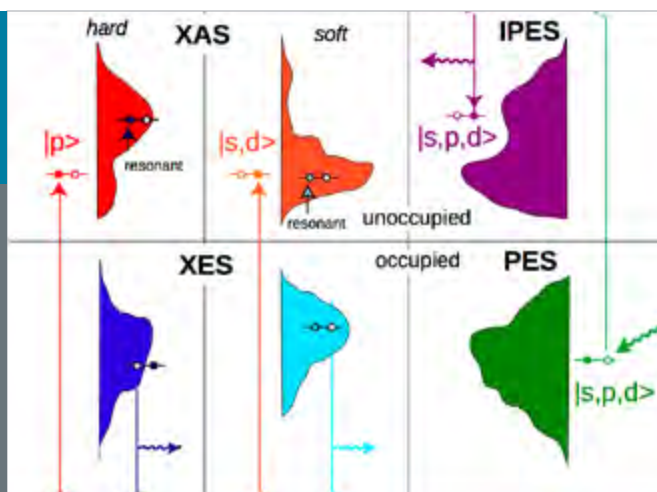

**FUNDING INFORMATION** \$0.3M | Bridging Research Interactions through Collaborative Development Grants in Energy | 11/2012–11/2015

## Project Description

Spectroscopic and diffraction measurements are being used in multiple energy ranges to probe different parts of transparent emitter layers (surface, near surface, and bulk) and interfaces in copper indium gallium selenide (CIGS) thin-film photovoltaic (PV) devices. The National Renewable Energy Laboratory (NREL) is working in collaboration with Stanford Synchrotron Radiation Lightsources to apply synchrotron radiation methods and other tools to support the development of a transparent emitter layer.

## Individual Reviewer Comments

- The program focuses on addressing one particular mystery of CIGS performance. It has taken a good approach of separating the bath/absorber interaction and recreating the CBD-like Cd(S,O) via ALD. The use of characterization techniques that might yield detailed mechanistic information on high-quality junction formation is a strength.
- Progress may significantly impact champion cell efficiency if secret recipes for a transparent emitter layer (TEL) can be identified.
- The replacement of CdS buffer layers by a less toxic and optically more transparent material is a key for further improvement of CIGS-based photovoltaic devices, but also for enhancing their acceptance. The interface chemistry of the CdS buffer/CIGS absorber interface is one important aspect, but not the only one that has to be understood in order to find a replacement for the CdS buffer layer. X-ray absorption spectroscopy (XAS) is an established tool to investigate such interfaces. However, investigations of the interface chemistry should always be complemented by investigations of corresponding devices. Although the outline of the project very concisely describes a line of actions that allows for a comparison of the CdS-related interface to interfaces with alternative materials, there is no perspective that demonstrates the device relevance of present or future results.
- There is opportunity to more clearly couple the reporting of the synchrotron studies to device performance and film properties; this does not seem to be part of the scope.
- The project team should consider optimizing and benchmarking the three splits (CBD, ALD, PE) to understand their influence on absorber and interface properties.
- The relevance of the project is moderate, given the project's status and prospects of CIGS PV manufacturing in the United States. Its approaches are reasonable, though not much value has resulted from them. The impact of the project is low, as it seems that in Year 2 of 3, there is not yet anything of great import from this project.
- The project's funding amount is low at \$0.9 million over 3 years. However, since the subject matter is so close to the NREL Annual Operating Plan project, it is not clear why this was broken out as a separate project.
- The lack of significant advances in the first two years of the three-year program is a weakness.

## PROJECT: 26191 NATIONAL RENEWABLE ENERGY LABORATORY

*National Center for Photovoltaics  
Core R&D Support*



**FUNDING INFORMATION** \$14.2M | National Laboratory Research and Development | 10/2012–09/2015

### Project Description

This agreement provides cross-cutting support required by the core research and development (R&D) agreements that make up the other photovoltaic (PV) laboratory agreements. Specifically, this agreement funds infrastructure support teams (Engineering and Informatics) and basic maintenance and limited enhancement of cross-cutting capabilities (Measurement, Characterization, and Device Processing). The direct funding of these cross-cutting activities through this agreement allows for more efficient management, increased flexibility in response to changes in program needs, and aids in ensuring that these crucial activities and capabilities are sustainably maintained as core competencies within the National Center for Photovoltaics (NCPV).

### Individual Reviewer Comments

- The project's relevance is high as infrastructure affects overall laboratory effectiveness. Its strengths include the availability of flexible, high-value tools (e.g., HVPE and the long-term competitiveness of the laboratories).
- The project's impact is moderate, as example project accomplishments (e.g., data system gains that mostly impact productivity), along with an HVPE tool that has not yet impacted specific R&D programs, are long-term facilitating investments and not high-impact projects themselves.
- Its funding is high; thus, it is important to know if any of these funds are "recovered" in subsequent specific projects. The approaches of the project are reasonable, but need more information on the full range of activities.
- It is difficult to evaluate this project, because it is an umbrella for organizing and supporting multiple subsidiary projects.
- Its weaknesses include very high dollar investments in specific tools and infrastructure that must return multiple years of high-value R&D to be worthwhile.
- There is no justification or description of the approach to decide on what to fund and why. It appears to be an unstructured slush fund. The major activity and result was completely discussed under a directly funded task.
- This is a poor way to allocate and manage funds. Unique capital equipment should be funded and managed under the appropriate project.

## PROJECT: 27388 NATIONAL RENEWABLE ENERGY LABORATORY

### *Approaching the Shockley-Queisser Limit with Epitaxial CdTe*

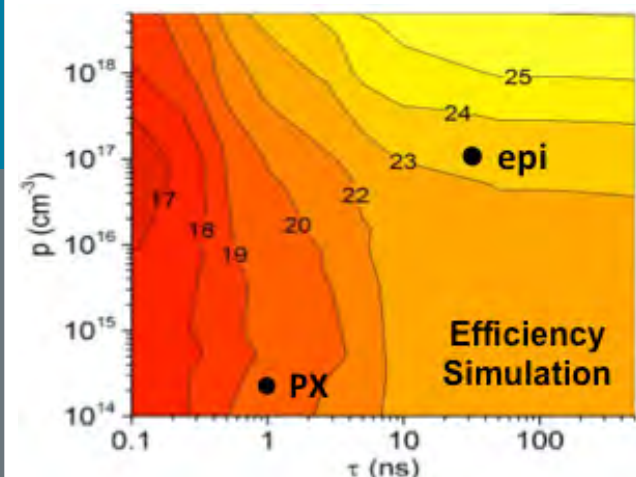

**FUNDING INFORMATION** \$4.5M | Foundational Program to Advance Cell Efficiency 2 | 09/2013–09/2016

### Project Description

The National Renewable Energy Laboratory, in collaboration with First Solar, Texas State University, Colorado State University, the Colorado School of Mines, and Washington State University, is using epitaxial cadmium telluride (CdTe) films that are grown by molecular MBE to reach power conversion efficiencies of greater than 24%. While traditional CdTe cells use a polycrystalline CdTe layer, this project will probe the limits for CdTe photovoltaics (PVs) using epitaxial materials on single-crystal substrates to develop a model CdTe cell. The insight provided in these investigations has the potential to advance the polycrystalline CdTe industry through a better understanding of interfaces, critical defects, surface passivation, and doping strategies for CdTe devices.

### Individual Reviewer Comments

- This project is very focused on attacking the most challenging aspects of the CdTe material system; namely, doping and lifetime to demonstrate high  $V_{oc}$ . The project works to improve the understanding of CdTe as a PV absorber material by using MBE techniques to grow model absorbers, which is not the standard deposition method in industrial processing. The hope is to gain by MBE a material, and finally, devices, that are superior to the materials from industrial processes.
- With a top-down approach, the impact of real world complications—such as grain boundaries, point defects, interfaces, and so on—should be understood in a more profound way. This issue is supported by numerical device modelling. The project carries a high risk in so far that experiences from gallium arsenide, where epitaxial growth delivers the highest material quality, cannot be

transferred to CdTe in a straightforward way. Conversely, there is a high risk that phenomena and problems may occur in MBE-grown material that have little in common with material challenges occurring in industrial thin-film growth.

- The three-pronged approach (sx, large grain, px) appears to be sound and holistic. Additionally, it should help to transfer learning and derive fundamentally correct conclusions. However, if one accepts that the approach is reasonable, the funding is appropriate because the infrastructure and experiments are expensive. This project is cheap because it is twice the price of its funding.
- The project's relevance is high, given the United States' position in CdTe PV manufacturing. However, its impact is limited by the likely transfer to commercial processes.
- The project's collaboration with other projects dealing with a similar topic remains to be discussed. It is also unclear if epitaxial CdTe is predictive or a useful reference for commercial CdTe materials and processes. The early results on surface defect densities underscore a long way to go.
- The budget is very high in terms of the narrow scope of work.
- The Principle Investigators present a comprehensive package to tackle the CdTe system for high-efficiency solar cells. However, the novelties of the approach are missing. It is not clear how high of an efficiency the PIs plan to achieve and what sort of roadmap they have planned for achieving their goal. Each task has about three to four team members. It is not clear why so many co-PIs are involved and what each team member's role is.

## PROJECT: 28308 NATIONAL RENEWABLE ENERGY LABORATORY

*Solar Energy Research Institute for India and the United States*

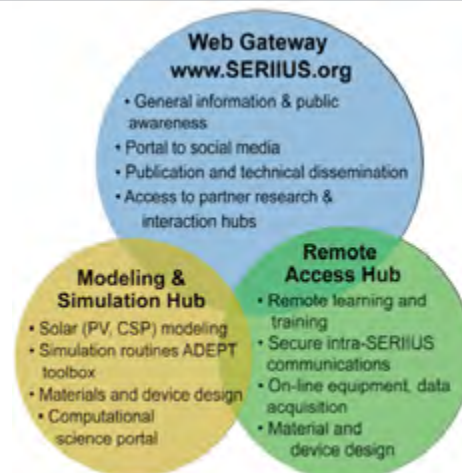

**FUNDING INFORMATION** \$6.7M | Crosscutting | 10/2011–09/2016

### Project Description

The Solar Energy Research Institute for India and the United States (SERIUS) creates a bi-national network for fostering new ideas and collaborations to expedite a sustainable industry. SERIUS is a joint effort between the National Renewable Energy Laboratory and the Indian Institute of Science in Bangalore to address critical barriers for solar energy development in India that intersect the grand challenges for solar energy in the United States. SERIUS has three research thrusts: (1) Sustainable Photovoltaics (PV), which aims to develop next-generation materials, devices, and advanced manufacturing processes tailored to the needs, environment, and resource availability of India and the United States; (2) Multiscale Concentrated Solar Power (CSP), which aims to overcome critical science and engineering challenges for reliable multiscale (including small 25–500 kilowatt) CSP systems; and (3) Solar Energy Integration, which aims to identify and assess key technical, economic, environmental, and policy barriers, enabling a research agenda for technical readiness in India and to benefit the United States.

### Individual Reviewer Comments

- This large team effort is likely to make a significant impact on solar programs in both nations. Evidenced by the teams' strong publication records (20 published and 6 under review [on the website]) and various major highlights in all 3 major thrusts, it is clearly a strong collaborative effort.
- International collaboration between the United States and India is a strength. Industrial partnership for the core projects is essential for the success of the PV program. Due to its large scale, the major outcomes and roles of the team members are difficult to be evaluated.

- The project aims to foster new ideas and collaboration between India and the United States to expedite sustainable industry. There was no evidence of expedited innovation as a result of this collaboration.
- The human resources exchange program is a powerful method of enhancing collaboration. This will generate a lasting relationship between the researchers. It will also foster future collaboration and empathy between collaborations, as each gets firsthand knowledge of the others' limitations, capabilities, and environments.
- The program has a specific focus on the development of economic and bankability computation tools. These are of paramount importance to ensure that research activities within the overall project are targeting relevant areas. These models should provide guidance to the participants on where to focus their activities. The program also includes wider issues, such as grid connection, storage, and integration. Understanding these issues as well as policy issues is critical to achieving the objective of a sustainable industry.
- The funding structure of the core projects focuses on getting industry participation, which is critical for ensuring that outcomes are industry relevant and deployable. The long list of industry partners demonstrates this low-hurdle rate for participation. The involvement of a large range of institutions and universities opens a wide range of capabilities that can be brought to bear on the technical activities; however, the breadth of activities included in the program obscures its focus.
- The project was allocated a large amount of funding relative to the benefits of the program; therefore, the project has too much bureaucracy, too little accountability, and too few key stakeholders.

## SYSTEMS INTEGRATION

SunShot funding is designed to accelerate cost-effective deployment of PVs on the distribution and transmission grids, demonstrate the feasibility of high-penetration PV scenarios under a wide range of system conditions through laboratory and field testing, and advance interconnection and performance standards and codes to enable high levels of PV integration for grid reliability. SunShot supports the development of state-of-the-art utility modeling, simulation, and analysis tools to address technical issues surrounding grid planning, operations, and reliability; advanced grid-friendly PV interconnection technologies; and validated inverter, solar system planning, operations, and feeder models to enhance PV integration analysis techniques. Through its funding programs, SunShot and its awardees engage with industry and stakeholders to inform and receive feedback on PV integration.



NREL engineers Greg Martin and Mariko Shirazi work on data capture for micro-grid synchronization wave forms at the Distributed Energy Resources Test Facility.

Photo credit: Dennis Schroeder / NREL

SunShot technical targets for grid performance and reliability:

- PV generation capacity >100% of peak load on the line segment of distribution feeder circuit
- Adverse effect of inverter conversion efficiency (associated with non-unity power factor) in the LCOE <3%
- Voltage Total Harmonic Distortion effect of PV <5% and individual harmonic <3%
- PV short circuit current contribution <1 per unit
- Interconnection study approval time is based on advance screening methodology <1 week
- Interconnection study cost to customer <\$1000
- Availability of quasi-static-time-series analysis modeling and real-time data analytics tools
- Advanced multi-inverter, anti-islanding schemes and certification tests validated and implemented for high-penetration PV scenarios.

## SI Overview

The Systems Integration (SI) program aims to dramatically increase the penetration level and enable widespread deployment of solar in the nation's electrical power system by addressing the associated technical and regulatory challenges. Considering a penetration scenario of 100 gigawatts of solar interconnected on the na-

tion's grid, the challenges are quantified and addressed in the activity areas of Grid Performance and Reliability, Dispatchability, Power Electronics, Communications, and Plant Performance and Reliability. The program funds projects at the national laboratories, industry, and universities (Figure 11) through competitive funding solicitations that map to the five activity areas and targets, as depicted in Figure 10.

Figure 10: Systems Integration activity areas mapped to funding opportunities

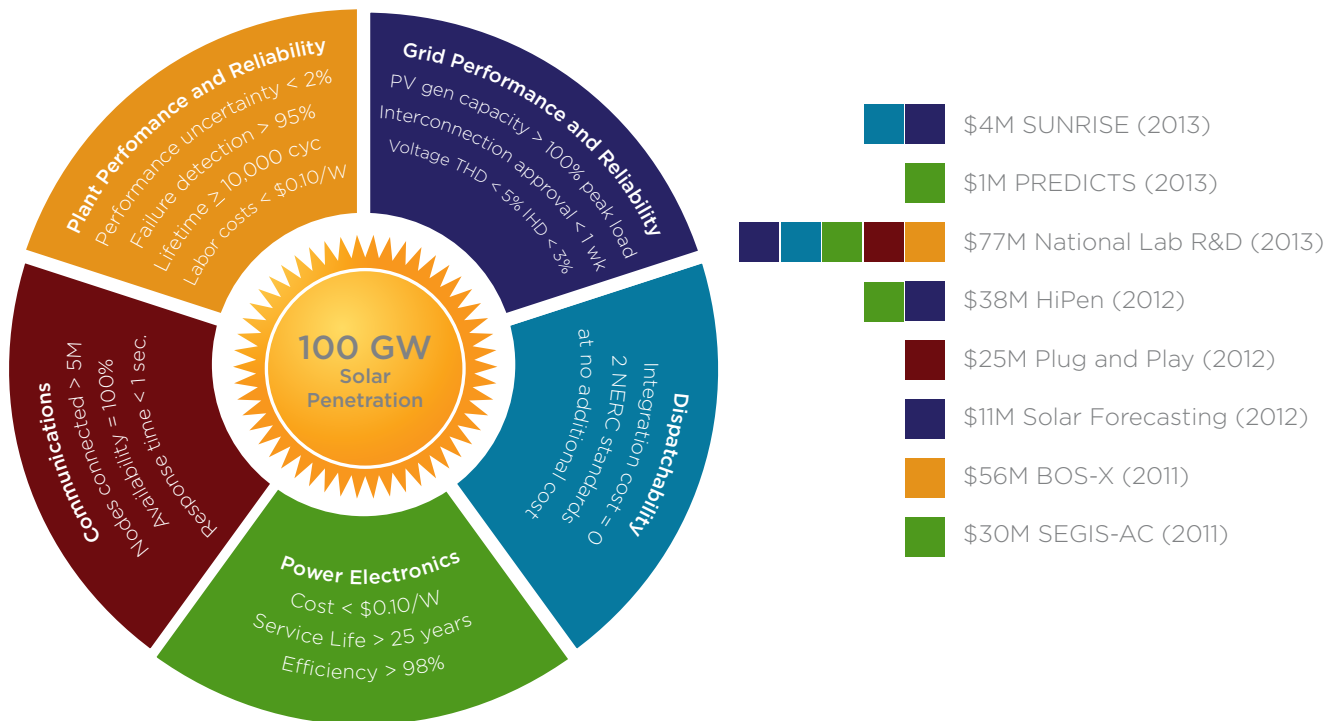

## Grid Performance and Reliability

The current projects in the Grid Performance and Reliability activity area focus on achieving high penetration at the distribution level (<69 kilovolt) and on the transmission grid in a safe, reliable, and cost-effective approach. In order to accomplish these goals, SunShot supports the following:

- Developing state-of-the-art utility modeling, simulation, and analysis tools to address technical issues surrounding grid planning, operations, and reliability
- Developing advanced grid-friendly photovoltaic (PV) interconnection technologies
- Accelerating cost-effective deployment of PV generation on the distribution and transmission grid
- Developing validated inverter, solar system planning, operations, and feeder models to enhance PV integration analysis techniques
- Demonstrating the feasibility of high-penetration PV scenarios under a wide range of system conditions through laboratory and field testing
- Advancing interconnection and performance standards and codes to enable high levels of PV integration for grid reliability
- Engaging with industry and stakeholders to inform and receive feedback on PV integration.



Figure 11: Systems Integration R&D portfolio funding distribution among national laboratories, industry, and universities in fiscal year 2013

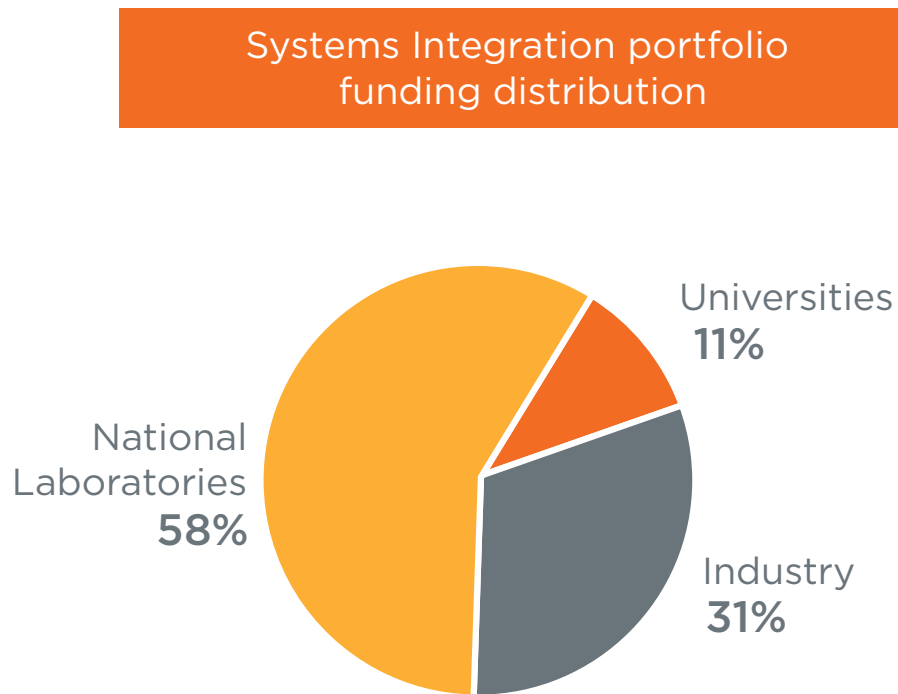

## Dispatchability

The Dispatchability activity area of the portfolio aims to ensure that solar power plants based on PV and concentrated solar power (CSP) technologies at utility and distributed scales are capable of being dispatched in a fashion that is comparable to or better than conventional power plants. SunShot addresses the issue of dispatchability with a two-pronged approach: (1) extensive analyses to understand the impact of the high penetration of solar power plants on the bulk power system and distribution system operations, and (2) research on understanding and enhancing the dispatch capability of PV solar power plants, as well as investigating the value of varying energy storage capabilities for CSP plants. SunShot also supports the development of standardized methods for testing grid performance of PV solar power plants and exploring and demonstrating the value of energy storage.

## Power Electronics

Power Electronics are intelligent devices that can maximize the power output from the PV arrays on the one side and serve as the interfaces to the electric grid (or end-use circuits) on the other, while ensuring overall system safety, reliability, and controllability. A technical challenge for power electronics is the optimal tradeoff among these three design drivers of performance, reliability, and cost. In order to accomplish these goals, SunShot supports cost reductions and efficiency improvements through innovative circuit design; development of advanced components and optimal control; development of power electronics technologies to improve energy yield, while reducing balance of system hardware costs, process costs, and installation time; development and field demonstration of smart inverter functionalities; and development of accelerated life testing methods and physics of failure models to predict faults and improve reliability.

The program also funds five regional test centers across the nation in support of this activity area.

The projects in the program’s portfolio address the goals of the five activity areas (Figure 12) toward the overall SunShot SI vision. The active projects in the five activity areas are briefly described in this volume. Building on the significant strides made so far, the program looks forward to continuing to advance the forefront of technologies toward the SunShot goal.



**Dr. Ranga Pitchumani**

*Chief Scientist and Systems Integration Program Manager*  
Solar Energy Technologies Office  
U.S. Department of Energy

**Team Members**

- Venkat Banunarayanan, SETA
- Michael Cliggett, Technology Manager
- Alvin Razon, SETA
- Guohui Yuan, SETA

**SI Portfolio Review Average, Range, and Standard Deviation**

Of the 251 projects in the SunShot Portfolio, 49 projects were reviewed as part of the Systems Integration portfolio review. Each reviewed project is listed in Table 8. Projects were ranked on a 1–5 scale, with “1” being the lowest possible score for a category and “5” being the highest score. Reviewers provided overall ratings on each project’s relevance to the SunShot and SI portfolio mission and goals, overall impact, level of funding, and approach taken.

For the SI portfolio, the overall average rating for a project was 4.19. Of the 49 projects, 26 were performing above the mean, while 23 achieved scores that were lower than the 4.19 average. The range of overall scores was 1.25, with a median of 4.25, mode of 4.00, and standard deviation of 0.29. This information is presented in

Table 7 and Figure 12. Overall, the data have a skewness of -.29 and are skewed to the left, as the mode is smaller than the mean, and the mean is smaller than the median. The reviewers’ comments on the program as a whole are provided in the following sections.

**Table 7: SI Portfolio Review Average, Range, and Standard Deviation**

	Average	Range		Standard Deviation
Relevance	4.51	4.00	5.00	0.33
Impact	4.15	3.00	5.00	0.40
Funding	3.93	3.00	4.67	0.39
Approach	4.16	3.00	5.00	0.40
Overall	4.19	3.58	4.84	0.29

Figure 12: Frequency of overall project rating for Systems Integration portfolio

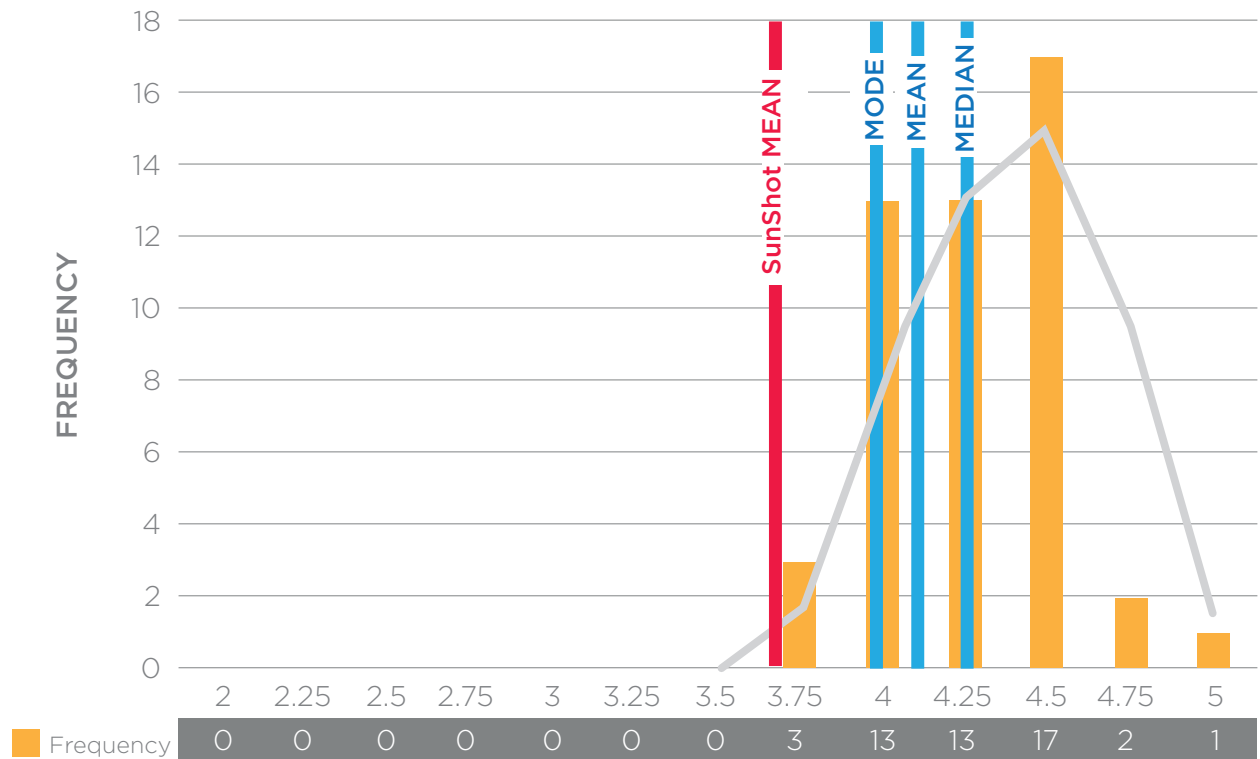

## SI Portfolio Reviewer Report

The following section contains the evaluation of the SI portfolio, as analyzed by the reviewers assigned to the portfolio. To preserve the integrity of the reviewer's responses, the analysis is provided almost verbatim, with minor edits for grammar.

### Quality and Impact of the Portfolio

One of the key strengths of the Systems Integration portfolio is that it is broad. As such, the portfolio covers forecasting, advanced inverters, distribution engineering practices, operating impacts, and experience standards. Reviewed projects were considered above average to superior and instill confidence that they will produce solid results, even subareas that had relatively few projects. The strongest projects were those that funded national laboratories and multiple partners. To keep the portfolio strong, the U.S. Department of Energy should continue to include utilities and grid operators from across the nation.

### Appropriateness of Funding Relative to Program Goals

The following topic areas were identified as being insufficiently funded in the current project portfolio:

- Impact studies on the solar generation, grid stability, and transmission operations
- Projects addressing systems integration of solar energy facilities
- Impact studies on distributed generation on the transmission grid planning and operations
- Analysis on unit commitment and dispatch, controlling ramp rates of scaled PV systems, and the role of energy storage
- Development and demonstration of advanced inverter components and systems
- Standards development activities for solar energy systems, components, and grid connectivity.

In addition, irradiance forecasting activities should reach commercial stage by the end of the current projects, but there may be the need for subsequent research to improve our predictive solar power production capabilities.

### Future Direction and Composition of Portfolio

Analysis conducted to better understand the value of adding energy storage to solar facilities and/or the electric grid would be of great value to the SunShot Initiative and its stakeholders. The analysis should involve various storage capacity thresholds, at different locations in the system and at various levels of market penetration, to support the introduction of intermittent resources. The study should be comprehensive and address nuances specific to the 10 regional transmission organizations operating in North America and should investigate battery and other applicable energy storage technologies, including thermal storage of CSP.

In addition, transmission operations need to be better understood knowing that this portfolio’s goal is to increase PV generation. More attention must be given to how increasing PV generation can be seamlessly incorporated into the grid operations.

The future direction and composition of the SI portfolio should include a value proposition assessment of the full spectrum of PV system services and benefits. The assessment should include complementary technologies such as advanced solar technologies, energy storage systems, and advanced inverters. A market framework that would incentivize the development of advanced solar energy and electric transmission and distribution technology needs to be investigated to support the SunShot Initiative. The full consideration of system and infrastructure advancements to achieve high levels of solar energy penetration into the market should be included in the investigation.

Table 8: Projects Reviewed under Systems Integration Program

Award Number	Project Name	Project Organization
4006	Utilization of Renewable Energy to Meet New National Challenges in Energy and Climate Change	Howard University
4679	Impacts of High Penetration of PV with Energy Storage at Flagstaff, Arizona	Arizona Public Service
4681	High Penetration PV with Advanced Power Conditioning Systems	Virginia Polytechnic Institute and State University
4682	Modeling and Analysis of High Penetration PV in Florida	Florida State University
5337	Smart-Grid Ready PV Inverter With Utility Communication	Electric Power Research Institute
5338	Development and Demonstration of Smart Grid Inverters for High-Penetration PV Applications	University of Hawaii
5340	Transforming PV Installations toward Dispatchable, Schedulable Energy Solutions	Advanced Energy
5341	Integrated Microinverters for Enabling True ACPV Modules	SolarBridge Technologies
5343	Extreme Cost Reductions With Multi-Megawatt Centralized Inverter Systems	Alencon, LLC
5344	Module Embedded Microinverter Smart Grid Ready Residential Solar Electric System	GE Global Research
5436	Development and Productization of High-Efficiency, Low-Cost Building-Integrated Photovoltaic Shingles Using Monocrystalline Silicon Thin Film Solar Cells	Solexel
5437	Deployable Commercial Rooftop Solar Electric System	GE Global Research
5440	Innovative Ballasted Flat Roof Solar PV Racking System	Cascade Engineering

Table 8: Projects Reviewed under Systems Integration Program

Award Number	Project Name	Project Organization
5441	Solar, Install, Mount, Production, Labor, Equipment (SIMPLE) Balance of Systems	Georgia Institute of Technology Applied Research Corporation
6016	A Public-Private-Academic Partnership to Advance Solar Power Forecasting	National Center For Atmospheric Research
6017	Watt-sun: A Multi-scale, Multi-Model, Machine-Learning Solar Forecasting Technology	IBM
6035	Plug and Play Solar PV for American Homes	Fraunhofer Center for Sustainable Energy Systems
6036	Development of an Innovative Plug and Play Photovoltaic Electric System	North Carolina State University
6323	DISTINCT: Diversity in Solar Talent through Innovative Curriculum and Training: An Integrated Research and Education Approach toward Creating Diversity and Advancing Utility-Scale Solar Technology	University of Texas at San Antonio
6326	Operational Simulation Tools and Long Term Strategic Planning for High Penetrations of PV in the Southeastern US	Electric Power Research Institute
6327	Comprehensive Solutions for Integration of Solar Resources into Grid Operations	AWS Truepower
6328	Model-Based Integrated High Penetration Renewables Planning and Control Analysis	PHI Holdings Inc. (PEPCO)
6329	Integration of Behind-the-Meter PV Fleet Forecasts into Utility Grid System Operations	Clean Power Research
6330	Intra-Hour Dispatch and Automatic Generator Control Demonstration with Solar Forecasting	University of California, San Diego
6331	Distributed Resource Energy Analysis and Management System (DREAMS) for Real-time Grid Operations	Hawaiian Electric Power Company
6332	Integrated Simulation Development and Decision Support Tool-Set for Utility Market and Distributed Solar Power Generation	Electric Power Research Institute
6458	Solar Forecast Improvement Project	National Oceanic and Atmospheric Administration
24348	Modeling and Analysis of High Penetration PV in California	National Renewable Energy Laboratory
24371	Regional Test Centers	Sandia National Laboratories and National Renewable Energy Laboratory
25794	Accelerating Development of Advanced Inverters	Sandia National Laboratories
25795	Accelerating Cost-Effective Deployment of Solar Generation on Distribution Grid	Sandia National Laboratories
25796	Advancing Solar Integration on Transmission Systems	Sandia National Laboratories
25798	Increasing Prediction Accuracy	Sandia National Laboratories
25799	Characterizing Emerging Photovoltaic Technologies	Sandia National Laboratories
25800	Advanced Measurement and Analysis of PV Derate Factors	Sandia National Laboratories
25801	PV System Reliability	Sandia National Laboratories
25802	Increasing Distributed PV Penetration Levels	National Renewable Energy Laboratory

Table 8: Projects Reviewed under Systems Integration Program

Award Number	Project Name	Project Organization
25803	Solar Value Analysis and Market Penetration Modeling	National Renewable Energy Laboratory
25805	Transmission and Alternatives Analysis and Strategic Stakeholder Engagement	National Renewable Energy Laboratory
25807	Operational Analyses, Models, and Tools Improvement	National Renewable Energy Laboratory
25808	Core Competencies for Solar Resource Assessment	National Renewable Energy Laboratory
25809	Emerging Technology Characterization	National Renewable Energy Laboratory
25810	Quantifying Risk through Bankability Reports and Standards	National Renewable Energy Laboratory
25811	Improvement and Validation of Solar Systems Modeling Algorithms and Tools	National Renewable Energy Laboratory
25812	Predicting Service Life for PV Modules	National Renewable Energy Laboratory
25813	International Electrotechnical Commission and National Electric Code PV Standards	National Renewable Energy Laboratory
26184	Solar Resource Modeling and Measurement Research	National Renewable Energy Laboratory
27378	Module Level Power Electronics Reliability and Accelerated Testing Standards	Sandia National Laboratories
255797	Advanced Solar Resource Modeling and Analysis	Sandia National Laboratories

## PROJECT: 4006 HOWARD UNIVERSITY

*Utilization of Renewable Energy to Meet New National Challenges in Energy and Climate Change*

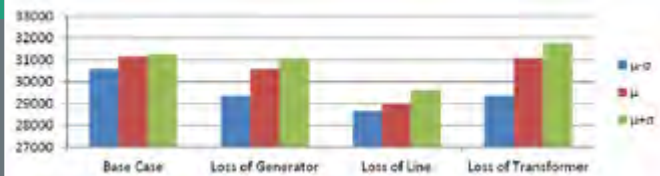

**FUNDING INFORMATION** \$0.3M | Minority University Research Associates | 09/2010–09/2014

### Project Description

This research project models integrated networks of renewable energy resources, and loads and evaluates the generation balance through appropriate storage and control design. As part of the project, design of performance indices will be developed for achieving generation/load balance, frequency control, and power quality and reliability under different disturbances. Education and training in this project includes high school, undergraduate, and graduate students in simulation and hands-on research development of the integrated scheme.

### Individual Reviewer Comments

- This project is an educational research effort geared toward educating high school, undergraduate, and graduate students. Several timely and necessary studies are being conducted by a number of researchers in this field.

- Some students have already published papers; others will be published next year. The Principle Investigator is doing a good job of educating next-generation solar engineers. The project's focus is on the modelling analysis of renewable energy systems.
- The funding amount for the project is on the low side. More funds may be needed to make excellent progress.

**PROJECT: 4679**  
**ARIZONA PUBLIC SERVICE**

*Impacts of High Penetration of PV with Energy Storage at Flagstaff, Arizona*



**FUNDING INFORMATION** \$2.2M | High Penetration | 01/2010–09/2014

### Project Description

The project team will evaluate the impacts of high penetrations of distributed photovoltaic (PV) and energy storage on a dedicated feeder to identify the technical and operational modifications that could be deployed in future feeder designs. Models describing the interactions between operations and weather/PV/feeder equipment are being developed and validated with actual feeder data so that results will be broadly applicable to other utility projects.

### Individual Reviewer Comments

- This project is very relevant to increasing the penetration of distributed solar PV. The findings could help allay utility concerns about much higher penetrations at the feeder level, depending on the configuration of the connected systems behind a given feeder.
- The team designed the project to meet the specific and practical needs of utilities as high penetrations begin to occur on certain circuits.

- The funding amount seems to be appropriate, given the mix of research and demonstration activities.
- The study has included several advanced scenarios, such as feeder reconfiguration, advanced inverter functionality, sizing/location of energy storage and voltage regulators, protection, and harmonics. A clustering study is discussed without any detail. Some of the results of the study have been shared with other utilities. Documents cite that one paper is to be presented, three more papers are under review, and one technical report is underway.



## PROJECT: 4681 VIRGINIA POLYTECHNIC INSTITUTE AND STATE UNIVERSITY

### *High Penetration PV with Advanced Power Conditioning Systems*



**FUNDING INFORMATION** \$2.6M | High Penetration | 04/2011–12/2014

### Project Description

Virginia Tech will develop and commercialize three advanced power conditioning designs that enable high-penetration photovoltaic (PV) systems without adversely impacting utility operation. The team is also establishing guidelines about the PV hosting capacity that a feeder can accommodate depending upon the feeder design, and will validate approaches to mitigate effects.

### Individual Reviewer Comments

- The project focuses on the performance verification and improvement of the 3 power electronics designs, including a 5-kilowatt single-phase string inverter, a 250-Watt (W) microinverter, and a 250-W microconverter. These converters were developed at a high efficiency and low cost. The designs have been performed to limit the use of electrolytic capacitors for reliability purposes. These designs have also been reported in the literature. One patent application has been filed. The development of reliable, low-cost, high-efficiency, high-performance power converters is a topic of importance.
- Microinverter/microconverter technology is an important research and development topic, balancing between reliability and economics (including efficiency). The project appears to be on the right track to achieving technology advances. It also seems well-tailored to achieving the goals of the project.
- This project is largely focused on the technologies that generally aim to lower the cost and/or improve the reliability of various converter and inverter components, thereby meeting several goals of the Power Electronics activity area. The project could potentially contribute to significant cost and reliability improvements. The string inverter technology would improve integration by providing grid support functions.
- The funding seems to be somewhat high compared to other projects in the portfolio.
- Grid connection is a major issue for PV. Other than voltage stability, the project team should be aware of other potential concerns that are facing grid-connecting smart inverters (e.g., islanding or alternate control modes), which may be pertinent to microinverters as well.

## PROJECT: 4682 FLORIDA STATE UNIVERSITY

### *Modeling and Analysis of High-Penetration PV in Florida*



**FUNDING INFORMATION** \$2.0M | High Penetration | 04/2010–10/2014

### Project Description

This project aims to leverage simulation-assisted research and development based on a wide variety of Florida feeders that already incorporate high levels of photovoltaic (PV) power. Working with utilities, the team will evaluate and model the impacts of the effects of high-penetration PV on distribution and transmission. Validated models that include the characterization of the Florida solar resource will be developed for the range of feeder designs. Additionally, power management solutions will be evaluated.

### Individual Reviewer Comments

- The project has pertinent and clearly defined objectives on capturing data and developing methodologies to overcome the challenges with integrating PV on distribution systems. The diverse set of distribution system models and data are valuable sources of information to the industry. The project produced concrete and precise analytical results on feeder voltage behavior, protection settings, and model aggregation for transmission impact analysis.
- The project is highly relevant to SunShot goals, and the team's analysis of PV impacts on both the distribution and transmission systems is a step forward. The research will have a significant impact on helping utilities to better understand the circumstances under which the addition of PV capacity can truly pose threats to power quality.
- The team's approach of modeling a range of values for PV capacity (relative to the feeder minimum and maximum loads, and distances of PV from the feeder) appears to provide very useful results for utility planning.
- To date, significant knowledge has been gained in the specific cases that were studied in the project to identify limits to high-penetration PV. The final set of deliverables will generalize this knowledge, as it is critical to successfully transferring the knowledge to designers conducting high-penetration-level PV studies throughout the United States.
- The funding amount seems to be a little high relative to comparable modeling projects in the portfolio.

## PROJECT: 5337 ELECTRIC POWER RESEARCH INSTITUTE

### *Smart-Grid Ready PV Inverter with Utility Communication*



**FUNDING INFORMATION** \$4.5M | Solar Energy Grid Integration Systems – Advanced Concepts | 09/2011–05/2015

### Project Description

The Electric Power Research Institute will develop, implement, and demonstrate smart grid-ready inverters with grid support functionality and required utility communication and control links to capture the full value of distributed photovoltaics (PVs). The key elements are: (1) head-end communications at the utility operations center through the integration of a distributed energy resource (DER) distribution management system (DMS), (2) back-end DER plant master controller, and (3) smart grid functionality built into inverters. PV inverter grid support functions will be put into practice using the distributed network communication protocol that enables utility operators from the central office-level DMS to interact with the plant. Real-world demonstrations will be carried out in three regions of the United States with four major utilities—each of which have different types of utility operating systems and implementations of utility-scale PV inverters.

### Individual Reviewer Comments

- The objective of the project is to develop, demonstrate, and implement smart grid inverters with grid support functionality; this seems to be a good approach. Thus far, the smart grid inverters have been tested in the laboratory, and the distributed network protocol (DNP3) is working. The project has a very good team that has made excellent progress to date.
- This project is the only project to demonstrate all 10 of the smart inverter functions of International Electrotechnical Commission (IEC) 61850-90-7. It successfully demonstrated all of the IEC 61850-90-7 functions with only a few bugs.
- The system impact analysis is model-based, showing the difference between using and not using smart inverters. It also shows how much higher the penetration level can go by using smart inverter functions. The team is now deploying devices in the field and beginning to do a system impact study on the grid.

## PROJECT: 5338 UNIVERSITY OF HAWAII

### *Development and Demonstration of Smart Grid Inverters for High- Penetration PV Applications*



**FUNDING INFORMATION** \$5.1M | Solar Energy Grid Integration Systems – Advanced Concepts | 09/2012–06/2015

## Project Description

The University of Hawaii will demonstrate the advanced residential photovoltaic (PV) solutions at two widely different utilities. On the island of Maui, smart PV inverters and control and management software will be combined with retrofits to existing PV inverters with the goal to evaluate the ability of the systems to mitigate voltage fluctuations caused by the variability of PV systems, contribute to grid stability during frequency excursions and faults, and report real-time PV output to both the utility and customer. The project team will also install new PV inverters with the goal of enabling higher PV penetration on a secondary distribution network.

## Individual Reviewer Comments

- This project is focused on assessing the use of smart inverters and inverter management control software for PV applications. The team is highly motivated, and has already conducted successful field tests at Maui Electric Company. This field testing is still in progress.
- A detailed distribution circuit model has been constructed in the Distribution Engineering Workstation environment for the Maui distribution circuit, which is targeted for advanced function inverter deployment. The model consists of circuit and equipment information from the substation 69-12-kilovolt transformer down to the single-phase feeders, service transformers, customer loads, and distributed PV systems with advanced function inverters. It seems as though project

volunteer recruitment activities are underway and in parallel with the rest of the activities.

- The project has several inverter vendors, including SMA Solar Technology AG, Hitachi, and Fronius. The team is using International Electrotechnical Commission 61850-90-7 functions and is aiding in developing the SunSpec test protocol for these functions. The lack of a certification process for these functions is the highest priority gap for the industry at this time. This SunShot project is critical to the progress in this area.
- Silver Spring Networks provides communications to the control center. This is not the distribution management system-managed inverter scenario, but rather, it is an autonomous process that monitors the local distribution feeder and uses the smart inverter functions to optimize locally; this is an interesting approach.
- There has been smart inverter deployment in both Maui and Maryland, which are very different types of distribution systems with different challenges. Maryland has been conservative with the penetration levels of distributed energy resources due to backflow limiters that were needed for the mesh network. The smart inverters are being used to help increase penetration levels without causing backflow problems. Power curtailment is a primary function for this application. In both cases, customers have dashboards based on Silver Spring Networks' implementation; however, this is not based on the national Green Button standards.

## PROJECT: 5340 ADVANCED ENERGY

*Transforming PV Installations  
toward Dispatchable,  
Schedulable Energy Solutions*



**FUNDING INFORMATION** \$3.1M | Solar Energy Grid Integration Systems – Advanced Concepts | 09/2011–06/2015

### Project Description

Advanced Energy will address three important needs in the further deployment of photovoltaic (PV) systems: (1) demonstrating and commercializing a new anti-islanding method utilizing phasor measurement units, (2) demonstrating a set of advanced grid support functionalities of power electronics, and (3) demonstrating a novel “ramp rate controller” to enable the control of the downward ramp rate of a PV plant under transient cloud conditions.

### Individual Reviewer Comments

- The major objective of the project is to develop an island detection algorithm to facilitate grid support functions and to improve feeder efficiency and operation through wide-area information and state awareness-leveraging synchrophasors. The team has developed these technologies and tested them at advanced energy laboratories, as well as at Sandia National Laboratories and the National Renewable Energy Laboratory. To date, the team has made good progress.
- The development of an island detection algorithm to facilitate grid support functions while maintaining island detection effectiveness and false-trip immunity has been implemented. Coordination between tap changers and inverter control to support voltage stability of the grid has also been implemented.
- By monitoring the system and knowing the algorithms that tap changes use, they know when the regulator is going to switch. The autonomous inverters use this information to adjust the regulation function accordingly. The result is a reduced number of tap changes, and, hence, better service life for the tap changer equipment.

## PROJECT: 5341 SOLARBRIDGE TECHNOLOGIES

### *Integrated Microinverters for Enabling True ACPV Modules*

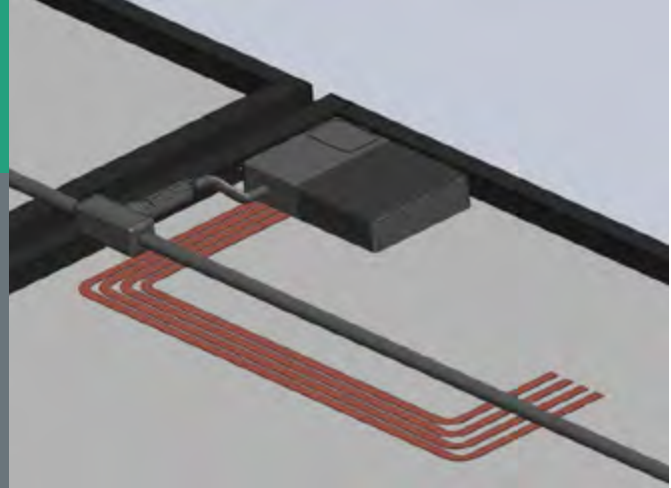

**FUNDING INFORMATION** \$1.7M | Solar Energy Grid Integration Systems – Advanced Concepts | 09/2011–12/2014

### Project Description

SolarBridge will develop a novel residential photovoltaic (PV) system, consisting of a PV module with an integrated “Universal PV-Dock” and a high-reliability, low-cost, high-efficiency microinverter. The collective system forms an alternating current photovoltaic (ACPV) module that simultaneously increases energy harvest and reduces balance-of-systems costs. The proposed system also addresses many practical aspects of the PV installation cost, such as supply chain and inventory management, late (or field) adaptation of products, and communications for data collection and performance monitoring, thereby yielding a substantially lower levelized cost of energy.

### Individual Reviewer Comments

- The project offers a very viable solution for low-cost microinverters. The project is well underway, as a microinverter has been designed and a prototype has been fabricated.
- The focus of the project is to design and develop a 320-watt ACPV module prototype and microinverter architecture. It employs a microinverter at each module and transmits AC power.
- The proposed system aims to reduce cost and improve the efficiency and reliability of the PV system. The design and development of the system is in progress.

## PROJECT: 5343 ALENCON, LLC

### *Extreme Cost Reductions with Multi-Megawatt Centralized Inverter Systems*



**FUNDING INFORMATION** \$3.0M | Solar Energy Grid Integration Systems – Advanced Concepts | 09/2011–12/2014

## Project Description

Alencon will develop and commercialize a new type of transformational power electronic technology to utility-scale photovoltaic (PV) systems based on novel, patent-pending ideas. A 99.1% efficient, centralized inverter with a capacity of up to 100 megawatts (MW) lies at the heart of the Alencon system. Feeding this single inverter is an advanced harvesting network that utilizes string-wise maximum power point tracking and high direct current (DC) voltage (2500 VDC) nodes that are easy to install and maintain.

## Individual Reviewer Comments

- The project focus is to develop, demonstrate, and commercialize a new type of utility-scale PV energy conversion system. This proposed centralized inverter system has capacities up to 100 MW and a high-voltage, string-wise maximum power point tracking harvesting approach. The proposed design appears to be

innovative. Two design iterations were completed for the grid inverter package.

- This project offers a modular solution for solar panels that seems to be viable. The team has fabricated proof-of-concept and pre-production prototypes. The progress that has been made so far is very satisfactory.
- The efficiency of the 0.5-MW current source inverter is about 99%, though the DC to DC inverter efficiency needs to be included.
- The 98%-efficient, \$0.20/W inverter will be competitive for multi-megawatt plants. It would be good to know if the cost can be reduced with this topology.

**PROJECT: 5344**  
**GE GLOBAL RESEARCH**

*Module Embedded Microinverter  
Smart Grid Ready Residential Solar  
Electric System*



**FUNDING INFORMATION** \$1.5M | Solar Energy Grid Integration Systems – Advanced Concepts | 09/2011–04/2015

## Project Description

GE will develop and demonstrate a new microinverter that is functionally integrated with the alternating current (AC) module to reduce packaging and materials cost for both the microinverter and the module laminate. It will also develop a new intelligent circuit breaker that reduces the microinverter cost by offloading duplicate safety and protection functions in an AC module system to a dedicated branch circuit.

## Individual Reviewer Comments

- A novel photovoltaic (PV) system topology was proposed, integrating a high-efficiency microinverter with the PV module and transmitting AC from the PV modules. The proposed design aims to improve

efficiency and reduce cost. The Primary Investigator appears to be highly motivated.

- The team has a good approach, though it is a little bit complicated. The first two phases of the project have been completed. A microinverter topology has been designed that is expected to reduce the cost of the current “best in class” microinverter, providing high efficiency (a target of 96%), a 25-year or more warranty, and reactive power support. Two versions of the converter for both thin film and silicon have been fabricated.
- The 96.4% efficiency is good for low-power levels of microgrid inverters. Getting rid of DC wiring is helpful for quicker installation.



## PROJECT: 5436 SOLEXEL

*Development and Productization of High-Efficiency, Low-Cost Building-Integrated Photovoltaic Shingles Using Monocrystalline Silicon Thin Film Solar Cells*

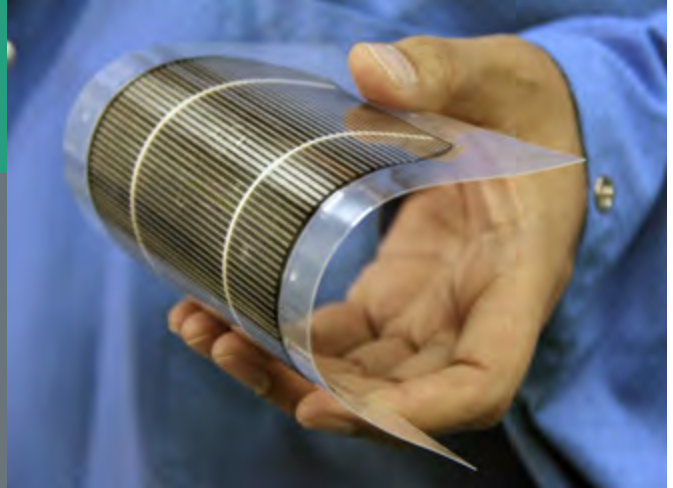

**FUNDING INFORMATION** \$7.2M | BOS-X | 09/2011–07/2014

### Project Description

Solexel is developing a building-integrated photovoltaic (BIPV) solar shingle product that demonstrates a business case for achieving a \$2/watt or less total installed cost residential BIPV system at large scale by 2017. The design is incorporating high-efficiency (>21%), flexible, thin monocrystalline silicon cells, very low-cost distributed power electronics circuitry at the cell level, and integrated microinverters.

### Individual Reviewer Comments

- The project is focused on developing solar shingles and assessing the technology by carrying out field trials. Planar solar shingles have been designed, fabricated, and tested. The design of the curved solar tiles has been completed. Additionally, early prototypes have been fabricated and tested.
- The concept appears to be novel, and the team appears to be committed to producing low-cost PV systems.
- It seems to be a very good approach; however, there was no presentation.

**PROJECT: 5437**  
**GE GLOBAL RESEARCH**

*Deployable Commercial Rooftop  
Solar Electric System*



**FUNDING INFORMATION** \$1.5M | BOS-X | 12/2011–12/2014

## Project Description

GE is developing a lightweight, mechanically interconnected, multi-module solar electric array that can enable total installed costs of less than \$2.50/watt. Its key innovations include an assembly weight of less than 2 pounds/square foot; significant reductions in racking weight, material handling costs, and installation time; an integrated busway; and optimization for project net present value based on higher energy production revenues on size-constrained commercial rooftops.

## Individual Reviewer Comments

- This project has an excellent team with complementary capabilities. The proposed modular solar array designs are highly innovative. The team has made excellent progress, and with the project's good approach, is on track to meeting the objectives of the proposal.

- For now, this system is for flat roofs. It includes rack, mounting, and wiring in the same unit with hinges. The system can be easily loaded and unfolded for installation. It does not require major investment to commercialize it, as it uses existing panel and glue. Considering that it only uses aluminum, it will not burn, thereby reducing the fire rating concerns and cost.
- The completed testing indicates that the project will have a good wind rating.
- The system minimizes roof penetrations because it does not require a special mounting rack of panels. The attachments are designed to fail at the bolt; thus, there is a reduced chance for leakage. The system will pass the testing phase this week and will be ready for installation next spring.

## PROJECT: 5440 CASCADE ENGINEERING

### *Innovative Ballasted Flat Roof Solar PV Racking System*



**FUNDING INFORMATION** \$0.60M | BOS-X | 12/2012–07/2014

### Project Description

Cascade Engineering is incorporating a number of material and labor-savings opportunities into a lightweight, low-cost, injection-molded plastic solar photovoltaic racking system. The goal is to reduce total balance-of-system costs by 25%.

### Individual Reviewer Comments

- The progress that Cascade Engineering has made is excellent; the project team exceeded the project performance cost targets. This project's research and development efforts have led to a current market price of \$0.15/watt for this solar rack product.
- The project seems to offer a simple and robust solution, which is good for its amount of funding; however, it

is limited to only a 5-degree slope of the roof. More funding may be needed to commercialize the product to a wider extent.

- Going forward, the plan is to demonstrate a 2-megawatt installation, which may happen in the near future. The company has confidence that it will last 25 years, since it has experience using the same materials to manufacture trash containers.
- The project already completed wind and fire testing, leaving only the thermal cycling test to perform.

## PROJECT: 5441 GEORGIA INSTITUTE OF TECHNOLOGY APPLIED RESEARCH CORPORATION

*Solar, Install, Mount, Production, Labor, Equipment (SIMPLE) Balance of Systems*

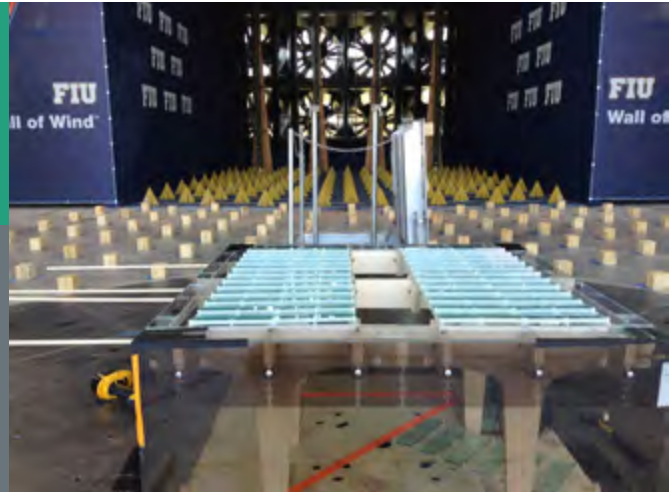

**FUNDING INFORMATION** \$2.8M | BOS-X | 09/2011–01/2015

### Project Description

Georgia Tech is developing residential, commercial, and utility solar photovoltaic racking and mounting systems that reduce hardware and labor costs by 50% over current industry best practices. Design innovations are being pursued across multiple pathways, including reduced part count, standardization, factory assembly, wire management, reduced roof penetrations, tool-less systems, assembly line integration processes, pre-panel assembly, significant material reduction, self-squaring, prefabrication, factory assembly, structural/material efficiencies, and self-stability/ballasting.

### Individual Reviewer Comments

- The proposed array design is novel and facilitates easy assembly. The project team is very good and motivated. Additionally, it educates next-generation solar engineers.

- The team uses computational fluid dynamics modeling and wind tunnel testing as a solution for panel mounting. This solution seems to be reasonable for achieving project objectives.
- The financing for the project has been made less risky by eliminating nuts and bolts that have to be accurately torqued. The system costs \$.08/watt.
- The project developed a system that works for all three applications, including ground mount, sloped roofs, and flat roofs. The rack has the longest span in the solar racking industry, and the team plans to install it with three different customers, along with SolarBridge on campus.

## PROJECT: 6016 NATIONAL CENTER FOR ATMOSPHERIC RESEARCH

*A Public-Private-Academic Partnership to Advance Solar Power Forecasting*

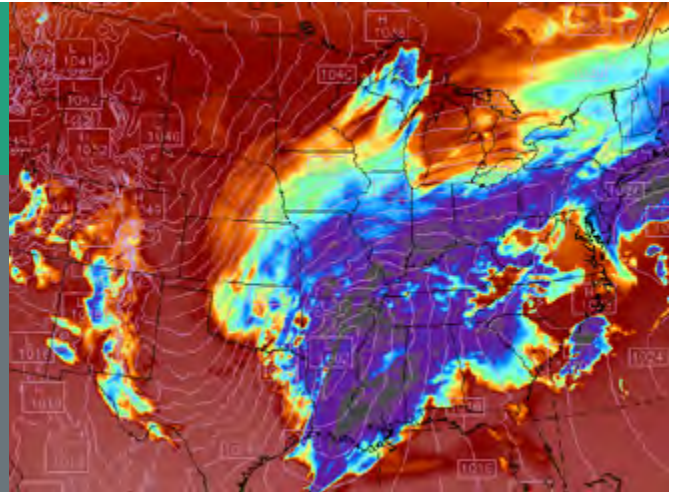

**FUNDING INFORMATION** \$4.1M | Solar Forecasting | 10/2012–09/2015

### Project Description

In this project, a solar power forecasting system will be configured to forecast across a range of temporal and spatial scales. The system technologies will employ solar radiation and cloud measurements, including images from total sky imagers; satellite observations; local meteorological observations; publicly available numerical weather prediction modeling results that includes the High-Resolution Rapid Refresh; Weather Research and Forecasting solar model tuned for cloud prediction and radiative transfer modeling; statistical blending of forecast technologies tuned to prediction times from 15 minutes to 36 hours; irradiance-to-power conversion models; displays tuned to the needs of the end user; and built-in assessment metrics. These technologies will be incorporated into a prototype solar power forecasting system that will be tested in collaboration with utilities and independent system operators (ISOs) in geographically diverse areas, including Long Island, Colorado, coastal California, and Hawaii. Each component will be verified and validated using specially designed evaluation techniques. The system will be deployed in the operational environments of utilities and ISO partners, with the engagement of commercial forecast providers who will tailor their methods to the needs of the deployment. This iterative process will incorporate user feedback. It will also assess the economic value of the forecasts. The results will be widely disseminated through publications, workshops, and software. The result of this effort will be enhanced solar power forecasting that is integrated into utility operations, thereby advancing the penetration of renewable energy.

### Individual Reviewer Comments

- The project focuses on the science of forecasting solar power generation. It has value in advancing the state of this science. The project team also recognizes the need to define performance metrics for solar power forecasting.
- The National Center for Atmospheric Research has assembled a strong and diverse team to collaborate on this project. The objective of the research is particularly well-tailored to the operational needs of utilities and regional transmission organizations/ISOs. The project team appears to have taken a thoughtful approach to systematically developing metrics to measure the accuracy and utility of their SunCast system.
- Given the highly technical nature of the research and the breadth of the project team, the funding level is quite reasonable.
- Examples of individual metric data are included, as well as an example of a Sacramento Municipal Utility District's forecast, which is not fully explained. More information on metrics would have been beneficial.
- The project may also benefit from a more solid understanding of how power system operators will use solar power forecasting, as well as an understanding of the impacts and remedies of forecasting errors. The ISO and local distribution utility have widely different requirements and remedies. Moreover, it is useful to recognize that even with no forecasting errors, PV integration is challenging. Effective metrics can be best developed when we better understand how the forecast will be used.

## PROJECT: 6017

### IBM

### *Watt-Sun: A Multi-scale, Multi-Model, Machine-Learning Solar Forecasting Technology*

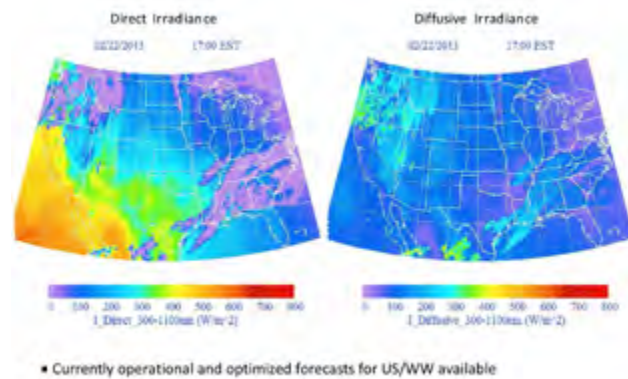

**FUNDING INFORMATION** \$3.9M | Solar Forecasting | 10/2012–09/2015

## Project Description

This work aims to develop a novel approach to solar forecasting, which will not only combine and integrate different prediction models, but also use state-of-the-art machine learning technologies to drastically improve the accuracy of predictions. Similar to the recently demonstrated Watson computer system, the proposed technology will leverage deep machine learning and self-adjusting voting algorithms to decide between various forecasting models and expert systems. The approach will yield the best forecasts, and, more importantly, continuously improve and adjust as the system is operating and evolving. The solar forecasting framework is independent of proprietary weather or solar radiation models and enables the technology to scale and be adopted by solar producers, electrical utilities, independent system operators (ISOs), and other stakeholders. The forecasting will also be validated at multiple sites with significantly different weather patterns. The team will work closely with utilities, solar power producers, and ISOs to integrate the proposed technology and to determine the value of solar forecasting on daily operation, load modeling, optimizing spinning reserve, and day-ahead planning.

## Individual Reviewer Comments

- The project is highly relevant to improving solar forecasting. This project, in particular, appears to have a strong likelihood of having a large impact on improving forecasts due to the machine learning approach and integration of multiple other predictive models.

- The funding is relatively high compared to most of the other projects in the portfolio, but may be appropriate to access the sophisticated computing technology that the project employs. Compared to the other projects, the approach is novel and seems to be capable of producing major advances.
- The project involves developing an advanced model for predicting near-term solar array output. It will take data from a variety of sources and develop a range of forecasts using machine learning algorithms. Improvements in the ability to forecast photovoltaic array output is important.
- The poster does a good job of stating the project's yearly goals. According to promising preliminary results, the project is at the end of Year 1 and is operating according to schedule.
- The gap between the irradiance forecast and the eventual power system operational requirements for solar generation forecast does not appear to be well understood by the project team. This is evident in the comment on how improved solar forecasting can enable solar energy to be a dependable and dispatchable power source. With perfect forecasting, solar power remains highly intermittent, and, thus, not "dispatchable." The challenge is to improve solar forecasting in order to enable power system operators to deal with the intermittent generation in an economic and reliable manner. It would be useful for the project to define forecast performance metrics that are meaningful to the context of power system operators.

## PROJECT: 6035 FRAUNHOFER CENTER FOR SUSTAINABLE ENERGY SYSTEMS

### *Plug and Play Solar PV for American Homes*



**FUNDING INFORMATION** \$8.8M | Plug and Play | 01/2013–01/2016

### Project Description

The Fraunhofer Center for Sustainable Energy Systems will develop a new plug-and-play photovoltaic (PV) system that self-checks for proper installation and safety, and communicates with the local utility and local jurisdiction to request permission to feed power into its smart meter. The utility and locality will remotely grant permission to the system to connect. The PV system will then immediately start to produce power to either consume in-house or feed into the distribution grid. In addition, the team will work with the national codes and standards community to identify hurdles for such a system, propose code changes, and develop technologies that will enable the system to be listed by Underwriters' Laboratories, and, thus, not be subject to local building inspections. The progress of the technology development will be demonstrated yearly with partnering utilities and localities.

### Individual Reviewer Comments

- The objective of this project is to develop a plug-and-play PV system for residential applications. The proposed design consists of microinverters, intelligent wiring harnesses, glassless PV modules, and an adhesive mounting system.

- The team has designed, fabricated, and installed a 2-kilowatt PV plug-and-play module on a sloped asphalt shingle roof. The team is making excellent progress and should be commended for it. The approach might transform how residential systems are being installed and permitted to achieve a residential roof goal of \$150/watt.
- Among the project's milestones are system electronics that are capable of self-testing for the safety of an installed plug-and-play PV system. Moreover, adhesively mounted lightweight PV modules—which pass the Class A fire rating, wind tunnel testing of 110 miles per hour, and key International Electrotechnical Commission 61215 requirements—is another milestone. The design, integration, and demonstration of a complete prototype plug-and-play PV system will be completed in the fall of this year.

## PROJECT: 6036 NORTH CAROLINA STATE UNIVERSITY

### *Development of an Innovative Plug and Play Photovoltaic Electric System*

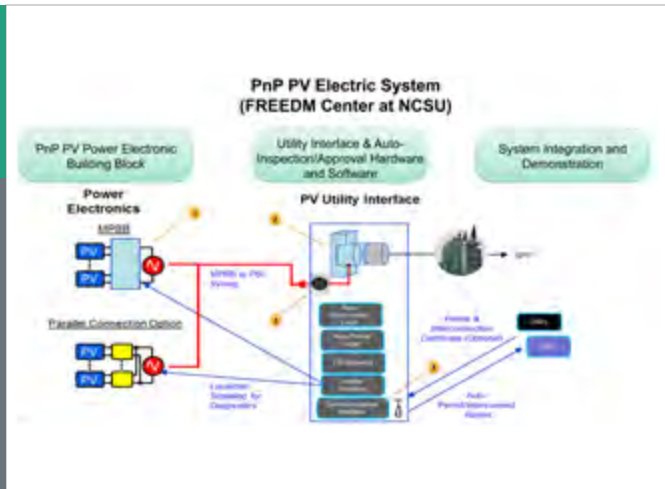

**FUNDING INFORMATION** \$2.2M | Plug and Play | 01/2013–04/2015

### Project Description

North Carolina State University's (NCSU's) Systems Engineering Center will develop a new plug-and-play photovoltaic (PV) technology to improve all aspects of residential solar PV systems through major innovation, refinement, and standardization. The key efforts are: (1) reducing the costs of the structural elements, installation, and mounting components; (2) reducing the cost and improving the performance and reliability of the electrical components; (3) simplifying the integration of the panels into the electrical grid, including communications, control, and safety considerations; and (4) designing for the market.

### Individual Reviewer Comments

- The project is focused on developing a plug-and-play PV system for residential applications. The proposed system employs micrometers (Pnp) for interconnections, multi-port building blocks, and utility-scale PV interface. The design is novel, and the project team collaborates with utilities and authorities that have jurisdiction.

- The project team finalized the plug-and-play system requirements. Additionally, development work is in progress. The team is highly motivated with complementary capabilities.
- Prototype power electronics were designed, a disclosure was filed with NCSU and cost breakdowns were created to measure the progress toward continually reducing the costs of power electronics relative to current market prices. Furthermore, a multi-port building block approach is currently under development.
- The project is developing a multi-port building block that has the benefits of a microinverter from the input side and a string inverter from the output side. The project finished the efficiency model for the multi-port approach, but the hardware has not yet been built. The multi-port has been designed, though multi-port power supplies are not unique to this project. It is unclear if much progress has been made.



## PROJECT: 6323 UNIVERSITY OF TEXAS AT SAN ANTONIO

*DISTINCT: Diversity in Solar Talent through Innovative Curriculum and Training: An Integrated Research and Education Approach toward Creating Diversity and Advancing Utility-Scale Solar Technology*



**FUNDING INFORMATION** \$0.75M | Diversity in Science and Technology Advances National Clean Energy in Solar | 09/2013–09/2016

### Project Description

This research is focused on the concept design and development of an innovative N-port power electronic converter that is modular, compact, and cost effective. The converter will provide a distributed, high-voltage internal electrical architecture with an integrated high-frequency, high-voltage, solid-state transformer. An integral component of this effort is to significantly enhance the “smart” integration of functionalities that go well beyond conventional grid support functions and accommodate solar resource variability due to widespread deployment of solar.

### Individual Reviewer Comments

- The focus of the project is to develop an N-port power converter system, integrated with a solid state transformer for large photovoltaic (PV) plants. The other objective is to train future solar engineers. The project is in its early stages of development and the work has focused on modelling and analysis. The program has good ties with a minority-serving institution, local utility, and Sandia National Laboratories. It may benefit from working with the National Renewable Energy Laboratory as well.
- This seems to be a viable solution for medium power applications. A multi-port power converter system, integrated with a solid-state transformer for large-scale PV plants in simulation, has been developed. The proposed converter is expected to be modular and compact. The proposal is progressing as scheduled.
- There is an educational aspect to this proposal that offers underrepresented communities opportunities for research and learning experiences, coupled with formal education on theory and practices of solar power. There are two Ph.D. students who are currently working on this project and three students with master’s degrees who will be hired to work on it.
- The project seeks to design and build a 13.8-kilovolt solid-state power substation based on 1700-volt silicon. The architecture for this goal is not well thought out; the project will have difficulty with both cost and efficiency due to the number of stages and high frequency transformers that require high voltage standoff.

## PROJECT: 6326 ELECTRIC POWER RESEARCH INSTITUTE

*Operational Simulation Tools and Long Term Strategic Planning for High Penetrations of PV in the Southeastern U.S.*



**FUNDING INFORMATION** \$0.87M | Solar Utility Networks: Replicable Innovations in Solar Energy | 10/2013–09/2015

### Project Description

In collaboration with the Tennessee Valley Authority (TVA), Southern Company, the Sacramento Municipal Utility District, the California Independent System Operator, and other partners, the Electric Power Research Institute will develop high-penetration solar future scenarios in the southeastern United States, distribution grid-feeder clustering and characterization, models for solar generation hosting capacity, and power production simulation. These tools, processes, and studies will be used to assess the full breadth of operational and business impacts posed by high levels of solar generation and formulate associated strategic plans for the southeastern United States that ensure both system reliability and utility financial health. This project will result in an end-to-end strategy and operations project that leverages prior efforts, including U.S. Department of Energy-funded projects, and provides a pathway for successfully integrating large amounts of solar generation. This project will further disseminate analytical results, operational tools, and strategic planning processes to allow for replication that advances photovoltaic (PV) integration beyond simply the traditional “sunny” regions.

### Individual Reviewer Comments

- The project covers several areas that are relevant to the System Integration activity area. By developing new methods for analyzing a large number of feeders, the impact of the project may be significant. The funding level is appropriate for the scope of the analysis.
- The project’s primary objectives are to develop strategic plans for PV integration in the Southeast and demonstrate the tools and data to other utilities. This is largely

an engineering exercise for the participating utilities; generally, it aligns with the goal of increased PV.

- In addition to conducting technical analysis, the fact that the project team will also investigate the ways in which solar deployment can support, rather than undermine, the utility business objectives, may help overcome utility opposition to rapid solar growth. This may be the most important barrier to the high penetration of solar.
- The use of a probabilistic production simulation tool to assess reserve procurement policy is highly encouraged.
- The project will build on several existing analytical tools, which may need to be adapted for the region under study. The resulting strategic plans should have a positive impact on the rate of PV deployment in the Southeast. They should also provide worthwhile information and methods for distribution systems with differing sets of characteristics from many previously studied systems.
- This two-year project will develop strategic plans for implementing high-penetration PV in the Southeastern United States. Both TVA and Southern Company are participating in the project.
- The scope of work covers transmission and distribution; however, there is little mention of a potential correlation and integration of PV models, along with operations considerations, between transmission and distribution. There is a sense of a business-as-usual approach, which may not produce the kind of value that might be expected.

## PROJECT: 6327 AWS TRUEPOWER

### *Comprehensive Solutions for Integration of Solar Resources into Grid Operations*

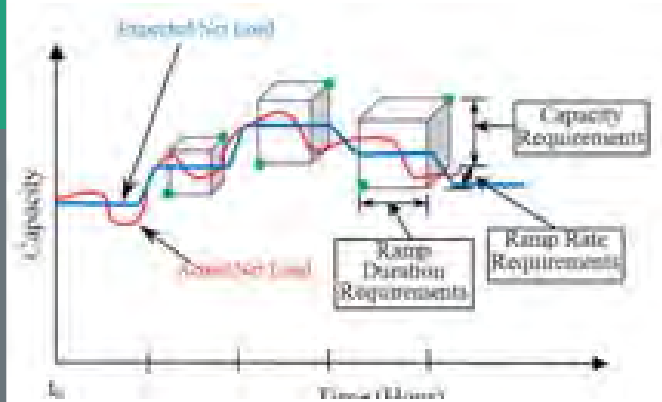

**FUNDING INFORMATION** \$0.39M | Solar Utility Networks: Replicable Innovations in Solar Energy | 10/2013–09/2015

### Project Description

This project primarily looks at the benefits of more cost-effective unit commitment and dispatch, as well as a reduction in balancing reserves due to decreasing uncertainty in solar forecasting. This project will improve the Pacific Northwest National Laboratory's ramp and uncertainty prediction tool by incorporating accurate forecasting of solar generation, and then integrating the tool with the Siemens market applications software that is currently being used by the California Independent System Operator (CAISO) to perform unit commitment and dispatch. This project will utilize probabilistic forecast algorithms for solar energy production in large-scale photovoltaic (PV) plants and rooftop PV installations in order to enable CAISO to incorporate solar generation forecasts directly into their tools that perform power system operations, thereby reducing the uncertainty and costs of integrating solar generation into the bulk power system.

### Individual Reviewer Comments

- The project has well-stated objectives that cover the two critical fronts of improving solar forecasting and PV integration. This is done by taking advantage of the improved forecast. Steps 2, 3, and 4 directly impact PV integration by enhancing operational procedures and tools in the utility/ISO system operation environment. The notion of a “flying brick” is aptly descriptive.
- The project is very relevant to near-term needs. By working directly with the ISO, the project has the potential to have a substantial impact on improving solar integration. The funding level is quite reasonable, given the scope of the project, and the approach seems to be comprehensive and well thought out.
- This project is still in its early stage, with no project results at this point in time. It builds on previous estimates from the investigators. The focus of the work will be on the Western Interconnection, and the proposers are hopeful that at least one of their tools will be integrated into the existing stochastic unit commitment software at CAISO.
- Accurate estimates reduce uncertainty and therefore cost. It is important to quantify the costs of inaccuracies in differing scenarios.
- The notion of “closed-loop” could be a mid- to long-term goal. Human-in-the-loop may be a more easily acceptable intermediate step.

## PROJECT: 6328 PHI HOLDINGS, INC. (PEPCO)

### *Model-Based Integrated High Penetration Renewables Planning and Control Analysis*

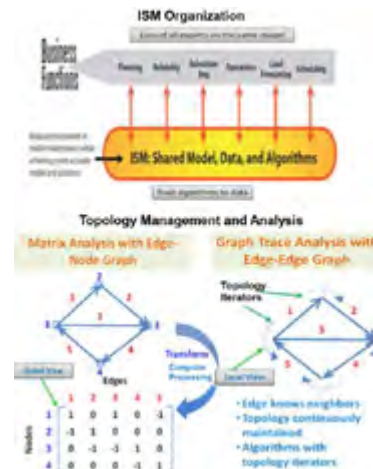

**FUNDING INFORMATION** \$1.0M | Solar Utility Networks: Replicable Innovations in Solar Energy | 10/2013–09/2015

## Project Description

This project will implement integrated transmission and distribution system high-penetration distributed energy resource (DER) interconnection, planning, monitoring and control analysis that will cover PEPCO's entire operating area. This project will quantify individual and combined effects of photovoltaics (PV) and DER, system configuration, equipment and control changes on renewable penetration levels, and system efficiency and reliability. It will also ensure that the common model and model-based algorithms allow same data, data validation, and analysis to be used for all activities. This project is expected to result in a significant increase in solar penetration capacity in the distribution system of 10%-15% beyond where it would be without the proposed project.

## Individual Reviewer Comments

- The objective of the project is to develop, within a utility business environment, a systematic framework, including business process, models, tools, and datasets to foster PV integration into utility operation and planning. This work will be directly relevant to SunShot Initiative objectives.
- Project deliverables will not only impact the hosting utility, but also be leveraged across other utilities. Feeder voltage headroom and distribution volt-VAR control are addressing two of the most pressing problems across the industry.

- The project is highly relevant to facilitating the integration of distributed PV. The project may be effective by helping utilities understand when upgrades are actually necessary and developing lower cost options to prevent the deleterious effects of high PV penetration. The funding level is quite reasonable, and the approach seems to be robust.
- Electrical Distribution Design is a partner of the project and will enhance the capability of the Distribution Engineering Workstation.
- A task of the project includes combining transmission and distribution models to model the interactions between these systems at high PV penetration levels. The successful completion of this task will improve the capability of the participating groups to address increasing levels of PV. It will be important to disseminate the results of this work to others in the industry.
- The team should consider fostering more explicit interaction between distribution and transmission activities associated with increased PV penetration.

## PROJECT: 6329 CLEAN POWER RESEARCH

### *Integration of Behind-the-Meter PV Fleet Forecasts into Utility Grid System Operations*



**FUNDING INFORMATION** \$0.5M | Solar Utility Networks: Replicable Innovations in Solar Energy | 10/2013–09/2015

### Project Description

This project looks at the improvement in the accuracy of load forecasting in California that can be realized from forecasts of behind-the-meter distributed (rooftop) solar photovoltaic (PV) generation. The forecasts that are developed are provided to the California Independent System Operator (CAISO) for incorporation into the Automatic Load Forecasting System whose load forecasts will quantify the influence of the increasing penetration of customer-sited or behind-the-meter PV system power production. Additionally, this project will evaluate distributed solar generation forecasting accuracy and apply further improvements in solar forecasting that the University of California, San Diego (UCSD) developed. Forecasting behind-the-meter distributed PV generation power production within a region will enable grid-balancing authorities to dispatch generation resources more effectively, significantly lowering the need for additional spinning generation reserves and mitigating the impact on existing reserve capacity. This project is expected to reduce the costs of integrating higher penetrations of PV into the grid by incorporating distributed PV generation forecasting into utility planning and operational tools in California, thereby offering a replicable and scalable approach that other areas of the country may follow.

### Individual Reviewer Comments

- The project is highly relevant to facilitating the integration of behind-the-meter PV, and its impact could be substantial. The project is generally aligned with the broad objective of facilitating increased PV penetration and improving utility/ISO operation for PV integration. The funding level is very reasonable, and the approach seems to be robust.
- The premise of this project is to provide CAISO a product that will forecast the amount of customer-owned PV generation, and then integrate this forecast into operational units. While the paper states that there are currently no products that explicitly forecast behind-the-meter PV system output, Clean Power Research provides CAISO with forecasts based on a “five-region designation.” Others are providing PV forecasts as well.
- The project schedule is outlined to collect system data, forecast the solar resource, and then simulate in order to develop the forecast. The poster includes a useful timeline.
- The team is in the early stages of the project. Partner UCSD is running the WRF-SolarCA weather forecasting model and archiving the results for future benchmarking. A secure file transfer protocol site has been developed to move data for future results.
- Relatively little information is new in the proposal, as evidenced by the “Key Findings and Outcomes” section. The work plan does not appear to be well coordinated, as there is no indication of the correlation between Key Finding 1 and 2. Moreover, Key Finding 3 gave little indication of its business insight/innovation, which is evident in the statements that reveal how FleetView, a commercial product, is being used to feed the ISO’s Automated Load Forecasting System for comparison against the results that do not use FleetView.

## PROJECT: 6330 UNIVERSITY OF CALIFORNIA, SAN DIEGO

### *Intra-Hour Dispatch and Automatic Generator Control Demonstration with Solar Forecasting*



**FUNDING INFORMATION** \$0.5M | Solar Utility Networks: Replicable Innovations in Solar Energy | 10/2013–09/2015

### Project Description

This project will demonstrate an operational tool for reducing costs associated with real-time dispatch and automatic generation control for different solar penetration scenarios in the Sacramento region. The innovative features of this project include a clustering analysis of the expected solar variability per region for the Sacramento Municipal Utility District (SMUD) system, day-ahead and real-time load forecasts for the whole-service areas and within clusters, and uncertainty quantification for integrated solar-load for both distributed and central station photovoltaic (PV) generation. This project is expected to reduce power system operation costs by committing appropriate amounts of energy resources and reserves, as well as providing operators a prediction of the generation fleet's behavior in real time for realistic PV penetration scenarios.

### Individual Reviewer Comments

- The project is highly relevant to facilitating the integration of PV. Its impact could be substantial by reducing the operational costs of integrating PV output. The approach that the project team has taken to develop the finer levels of temporal and spatial granularity in forecasting will make a valuable contribution. The funding level is also very reasonable.
- The project has well-stated and relevant objectives in the context of increased PV penetration. They focus on utility integration and consider reliability and economic impact. There is good awareness of the impacts of uncertainties and the intermittency associated with PV.
- This project is a collaboration between the University of California, San Diego and SMUD. The overall focus of the project is to reduce the system-level costs that could arise due to large-penetration PV. In particular, the focus is on real-time dispatch and automatic generator control for the SMUD service region. SMUD appears to be a good case study for this project, because its use of clustering is good.
- The two-year project has just completed its sixth month. The results focus on a geographical clustering study that uses the average daily clear-sky index and the average daily variability index to identify the clusters. The value of this level of clustering is not clear in this particular case. The variability index is based on the magnitude of the sample-to-sample variation. It would be useful to know the time increment of these samples. These will be applied to GHI data from Clean Power Research's Solar AnyWhere dataset from 2009 to 2013. This clustering was applied to the hour-ahead and day-ahead forecasts for the last 3 months of 2013, and the results showed good improvements compared to the present SMUD forecaster. There is a recognized need to improve the capability of hour-ahead and day-ahead PV array output forecasts; therefore, this approach seems to have some merit.
- The project work plan, as described in the second part of the "Objectives" section, does not appear to be consistent with what is described in the "Key Findings and Outcomes" section. Despite what is described in the summary report, as inferred from the poster, it is possible that valuable work has been done.

## PROJECT: 6331 HAWAIIAN ELECTRIC POWER COMPANY

### *Distributed Resource Energy Analysis and Management System (DREAMS) for Real-time Grid Operations*



**FUNDING INFORMATION** \$0.50M | Solar Utility Networks: Replicable Innovations in Solar Energy | 10/2013–09/2015

### Project Description

Hawaii has two different energy management systems (EMS) on the islands of Oahu and Maui, and already has very high solar penetration. This project will design new capabilities for these systems to enable visibility to thousands of uncontrolled, distributed rooftop photovoltaic (PV) resources, as well as factor-advanced, 15-minute, short-term wind and solar forecasting capability for the region and the EMS decision-making process. This project is innovative because it incorporates solar generation forecasts into the operational EMS and works with two major EMS vendors (Siemens and Alstom) to create advanced EMS software. The results of this project will motivate the development of technology to enable operational change under high renewables penetration, thereby reducing the cost and impact of integrating large amounts of solar.

### Individual Reviewer Comments

- This project addresses the integration of variable renewable generation into the power grid. It proposes a user-oriented approach to upgrading energy management systems, using probabilistic forecasts, distributed energy, and variable energy inputs.
- The project appears to be very relevant to near-term utility needs. As a utility-driven project, it has a high likelihood of producing a substantial impact. The funding level is quite reasonable, and the approach is very focused on achieving the pragmatic goals of the project.
- The poster shows preliminary human-machine interfaces; however, there is little information on the slide describing the development of a value-added service at this stage of the project. The discussion revealed significant goals and methods that will be used in the project.

## PROJECT: 6332 ELECTRIC POWER RESEARCH INSTITUTE

*Integrated Simulation Development and Decision Support Tool-Set for Utility Market and Distributed Solar Power Generation*



**FUNDING INFORMATION** \$0.42M | Solar Utility Networks: Replicable Innovations in Solar Energy | 10/2013–09/2015

### Project Description

This project will develop a simulation and decision support toolset that simulates the utility grid in real time. It contains a decision support system for effective integration of centralized and distributed solar power generation. This toolset, which is designed for real-time operations personnel, will be integrated within existing utility procedures. The distribution management system will enable a real-time simulation of distributed solar photovoltaic (PV) generation in the San Diego Gas & Electric (SDG&E) territory. The methodology and enabling software will be available to utilities and their ratepayers across the United States for widespread adoption and cost benefits. This project will further result in improved day-ahead generation commitments and real-time operations, as well as increased reliability and system balancing from improved visibility, enabling more efficient and innovative management of utility assets.

### Individual Reviewer Comments

- The project is highly relevant to solar integration and may be of significant impact. The relevance of the project lies in its explicit focus on utility practices that directly impact and/or are impacted by increased PV penetration. In particular, these are broad spectrum practices, ranging from classical distribution operation to competitive market operation.
- Herein lies the key contribution from the project: identifying the critical requirements for an integration across business activity boundaries and diverse data sources. This is a real challenge facing the utility industry (connecting actionable information across business/information silos).
- This project is intended to provide utilities with strategic planning tools that will allow high-penetration levels of intermittent renewable generation. The team initially identified 20,869 PV installations and 250 service transformers for pilot analysis. The goal is to develop a tool capable of forecasting distributed generation PV at any location on the SDG&E system. The lessons learned from this project include both the complexity and effort that is required to develop detailed circuit information.
- To date, two of six technical tasks have been reported. The first task identifies current levels of PV penetration and considers clustering and advanced metering infrastructure load aggregation. The second task calls for a determination of the impacts and mitigation methods that power system operators need. The remaining tasks will develop simulation and forecasting tools, disseminate generated data, and install enhanced advanced hardware and software. Limited detail was presented on these tasks.
- The funding amount is reasonable, given the scope of the project, and the project's approach is appropriate for reaching its goals.
- Some of the project's actions and objectives are a bit too broad (e.g., "enhance simulation capability").



## PROJECT: 6458 NATIONAL OCEANIC AND ATMOSPHERIC ADMINISTRATION

### *Solar Forecast Improvement Project*



**FUNDING INFORMATION** \$2.0M | Solar Forecasting | 02/2014–01/2017

### Project Description

The U.S. Department of Energy will work with the National Oceanic and Atmospheric Administration (NOAA) as well as the awardees of the Solar Forecasting funding opportunity, which include the National Center for Atmospheric Research (NCAR) and IBM, in order to provide a pathway to publicly disseminate weather model improvements resulting from NCAR's and IBM's research on solar forecasting. This activity falls under the Memorandum of Understanding that the two agencies signed in 2011, in which they agreed to collaborate to advance the science and services needed in support of weather-dependent and oceanic renewable energy. NOAA will consult with IBM and NCAR in areas of NOAA's expertise, including numerical weather prediction (NWP), irradiance forecasting, cloud-tracking algorithms, ground-based measurements, model verification, and metrics. Further, NOAA will provide baseline global horizontal irradiance (and later, direct normal irradiance) forecasts from the 3-kilometer (km) High-Resolution Rapid Refresh (HRRR) and an advanced version of the 13-km Rapid Refresh (RAP) models. NOAA will provide these grids and all other needed model grids, as well as consult the NCAR and IBM teams, as needed, on the use of the model fields. NOAA will also provide a clear pathway for HRRR, RAP, and NWP model assimilation from research into the NOAA operational model suite, thus realizing the goal of operational solar forecasts.

### Individual Reviewer Comments

- The relevance of the project is in its focus on improving solar irradiance forecasting. NOAA and NCAR are known for their expertise and solutions in this area.
- The tasks that are described in the project summary are certainly relevant, and the research that the award funds may have a substantial impact on improving solar forecasting. In this project, NOAA personnel will take data from Geostationary Operational Environmental Satellites to provide frequently updated forecasts to be used for solar power prediction. Fifteen-minute and one-hour updates are mentioned; these may have the potential to improve grid operation. The advances that are mentioned include low cloud building, soil temperature, and irradiance from radiative transfer, among others. The results will be validated from ground stations.
- The funding amount seems to be reasonable for the described tasks; however, the major weakness of the research plan is its lack of specificity regarding the “metrics” and “incorporation in system operations” subtasks. The project summary notes that NOAA's participation in the project is just starting and these subtasks may be more fully elaborated in the future.
- The impacts of “improved” irradiance forecasting on increased photovoltaic deployment deserves more attention. Performance metrics for solar forecasting should reflect the context use case of the power system activities (e.g., Independent System Operator balancing and distribution feeder voltage violations). Experts from NOAA and NCAR need better support from the power industry to guide them in specific areas of improvement (e.g., spatial precision, rate of change of irradiance, uncertainty range, and time frames of interests).

## PROJECT: 24348 NATIONAL RENEWABLE ENERGY LABORATORY

### *Modeling and Analysis of High Penetration PV in California*

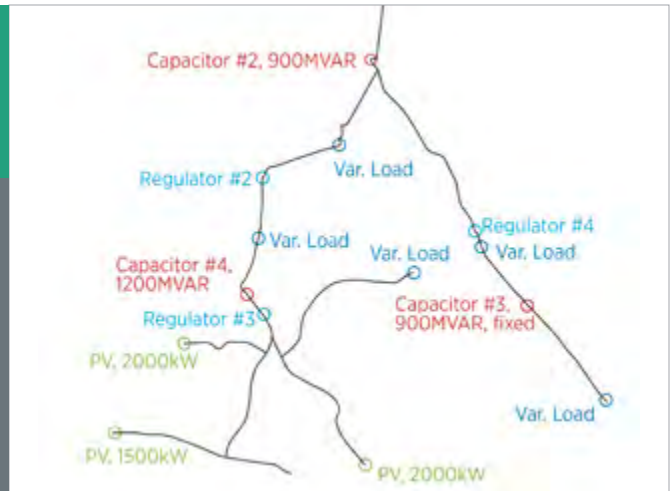

**FUNDING INFORMATION** \$3.3M | High Penetration | 10/2009–09/2014

### Project Description

The project team will utilize field verification to improve the ability to model and understand the impacts of high-penetration photovoltaics (PV) on electric utility systems and develop solutions to ease high-penetration PV deployments. The team will develop and verify advanced modeling and simulation methods for distribution system planning and operations; define the impacts of high-penetration levels of PV on the distribution and transmission grid with high-fidelity simulation tools; develop a handbook of validated models and solutions for the stakeholder community; and provide simulation-assisted evaluation/de-risking of technology solutions to enable successful integration of high levels of PV.

### Individual Reviewer Comments

- The project's high level of relevance and potential impact are based on its strong focus on promoting PV integration onto the utility grid by: (1) analyzing the impacts on distribution system operation, (2) demonstrating that a smart inverter can be effective in mitigating the adverse impacts of PV, and (3) disseminating the know-how through a handbook to practicing it with utility distribution engineers and other interested parties.
- The project is highly relevant to facilitating the uptake of distributed PV. Its impact could be substantial. The approach of conducting an analysis of system impacts, demonstrating advanced inverter technologies, and developing a handbook to disseminate the lessons learned is a comprehensive strategy for addressing the issue and improving industry practice.
- The project will develop a high-penetration PV integration handbook, which will be based on the experience that was gained at Southern California Edison where 50 megawatts (MW) of 1-5 MW PV installations were being installed on distribution feeders. The project results include a flicker evaluation and a mitigation analysis. An analysis of time overcurrent protection impacts is also included. The lessons learned from the installations should be significant, though few details are offered in the materials. It will be worthwhile to develop and disseminate a good handbook.
- The work on smart inverter technology is very important; thus, it is suggested that the lessons learned from Germany should be incorporated into the testing and future specification of smart inverter standards.
- The funding level is somewhat high compared to other projects in the Systems Integration portfolio.

## PROJECT: 24371 SANDIA NATIONAL LABORATORIES AND NATIONAL RENEWABLE ENERGY LABORATORY

### *Regional Test Centers*



**FUNDING INFORMATION** \$12.0M | National Laboratory Research and Development | 10/2011–Ongoing

### Project Description

SunShot established the Regional Test Centers to further develop standards, establish a technical basis for photovoltaic (PV) bankability/economic viability, provide geographically diverse test beds for large-scale system demonstrations, and offer technical assistance and independent validation of PV performance and reliability.

- The program seems to have had good progress. The sites, which were selected in 2011 and 2012, are located mainly in places with severe climates. Each site has already undergone some setup, though more test beds are being installed.

### Individual Reviewer Comments

- The major objective of this project is to establish and operate five regional PV test centers for the validation of performance and reliability in different climates. The team has installed approximately 140 kilowatts (kW) of PV, and the installation of another 293 kW is in progress. This is an essential service to the PV industry and the community.

## PROJECT: 25794 SANDIA NATIONAL LABORATORIES

### *Accelerating Development of Advanced Inverters*

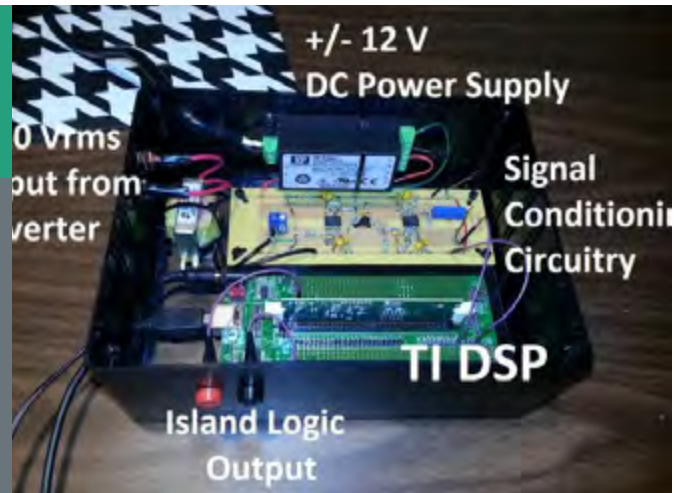

**FUNDING INFORMATION** \$2.6M | National Laboratory Research and Development | 10/2013–09/2015

### Project Description

This project will enable the use of inverter grid support and ride-through functions on distributed generation resources by addressing issues with islanding and the implementation of manufactured inverters through the development of an affordable communications-based anti-islanding scheme; collaborative controls that provide grid support and prevent islanding; and testing procedures that validate function performance.

### Individual Reviewer Comments

- The relevance of this project is in the design of the islanding detection mechanism, which is a relatively narrow focus, but nevertheless important component for interconnecting photovoltaic (PV) devices to the grid.
- This project addresses the medium-term needs of improving inverter performance, allowing PV systems to ride through disturbances. Advanced standards could significantly facilitate higher penetrations of solar PV.
- The funding level is reasonable for the project's scope of the work. The overall approach is also good, as it recognizes the limitations of existing technology and attempts to develop an innovative alternative that makes use of phasor measurement unit and power line carrier technology.
- This project involves using PV array inverters to provide volt-VAR support as well as frequency support for the power grid. The potential advantage of providing voltage support with these inverters is well understood. The potential of these systems to provide frequency support is less clear and could be more fully explained.
- At the current stage of the project, the focus has been on interactions between voltage support and the anti-islanding controls that are required of these inverters. Simulation studies that were performed in the first year of the project have indicated that extended dropout times could occur when voltage support is added to existing inverter controls. The mechanism for this is unclear.
- The project team has proposed and is investigating three alternate schemes for anti-islanding control; two of which involve system-level hardware, while the third, apparently, does not. It appears as though the economics will dictate against one or more of these schemes—this should be considered before extensive prototyping is performed. While it is expected to be a significant issue, the report does not mention the dynamic interactions among tens or hundreds of PV inverters performing voltage regulation.
- The project team should consider closely coordinating with other smart inverter research and development and standardization activities.

## PROJECT: 25795 SANDIA NATIONAL LABORATORIES

### *Accelerating Cost-Effective Deployment of Solar Generation on Distribution Grid*

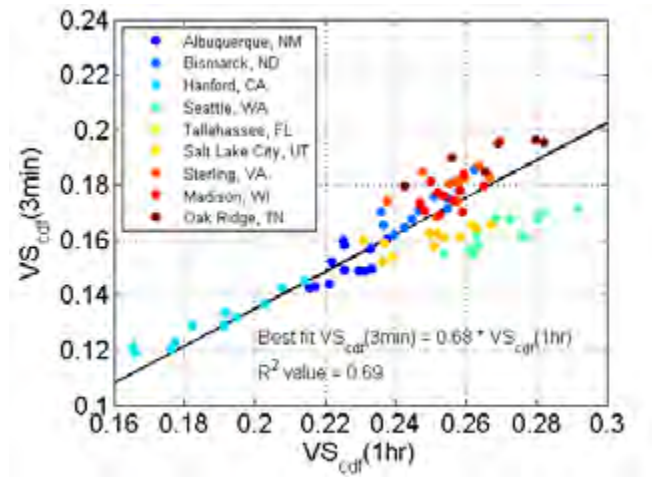

**FUNDING INFORMATION** \$3.3M | National Laboratory Research and Development | 10/2013–09/2015

### Project Description

The goal of this project is to remove grid access barriers, reduce the cost for solar generation, and produce the following outcomes: (1) provide a full and complete data-driven technical foundation that supports revised small generation interconnection procedure (SGIP) screens, (2) develop new ways to use feeder classifications to estimate possible impacts of high-penetration scenarios, (3) develop a tool to create high-resolution solar data for any location on a feeder so that utility planners and university students can use it to conduct impact studies, and (4) develop new screening procedures and implement new SGIP screens nationwide.

### Individual Reviewer Comments

- The project has a major focus on expediting the photovoltaic (PV) connection process, which will facilitate timely PV project execution. This is very relevant and may have a significant impact on increasing PV penetration.
- This project explores methods for improving the interconnection process through a multi-pronged approach of analyzing data from interconnection studies, developing new screening criteria to minimize unnecessary interconnection studies, and better modeling irradiance variability. The development of improved fast-track screening protocols could significantly reduce the time and cost to interconnect, thereby improving the economics of the project.
- This project seeks to improve the cost-effective installation of PV resources on the grid. The primary focus of this discussion is on the need to improve the PV screening process and methods for reducing the rate of unnecessary studies. These are worthwhile goals.
- The funding level is appropriate for the scope of activity, and the approach is grounded in meeting practical and short-term industry needs.
- One of the project's other objectives involves a feasibility analysis of generating representative high-frequency solar output data. It is less clear, however, what the impact is of high-frequency (1-second) solar input on distribution system operation.
- The results focus on analyzing multiple load flow studies on a given feeder for numerous scenarios and reporting on the rate of thermal and voltage violations. It is not clear if the screening tool will be limited to thermal/voltage issues or will later include other issues that need to be considered for a successful screening tool.
- The project addresses the clustering of feeders, the details of which were explained in the session. It also talks about low- and high-frequency variability zones; however, there was little information presented that connected this part of the study to the goal of improving the screening tools.
- As a justification for expedited screening, the project cited that 44% of interconnection studies are non-impact cases. The justification might be more convincing if it could also: (1) ascertain that 56% of those studies that are having an impact would not be missed by the expedited screening, and (2) address the number of filings that did not require interconnection studies.
- Regarding variability modeling, it is not immediately obvious why the annual data would be meaningful for inferring correlation between high- and low-frequency measurements. It would also be useful to justify the cases of business use for high-frequency measurements in distribution system operation.

## PROJECT: 25796 SANDIA NATIONAL LABORATORIES

### *Advancing Solar Integration on Transmission Systems*

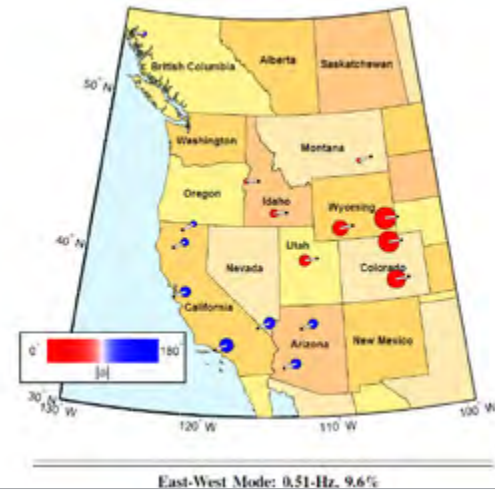

**FUNDING INFORMATION** \$3.1M | National Laboratory Research and Development | 10/2012–09/2015

### Project Description

Sandia's three-year integrated program incorporates elements of each of the SunShot Transmission Grid Integration (TGI) research areas: System Integration Study Template, Models and Tools Improvement, and Transmission Analysis and Transmission Alternatives. Strategic stakeholder engagement and information dissemination are also an integral part of the proposed activities in order to ensure the broadest possible impact. The work plan is organized into four tasks: (1) improve simulation models for solar generation interconnection and grid planning, (2) improve methods and tools for the analysis of high-penetration scenarios, (3) evaluate the technical feasibility of high-penetration solar deployment, and (4) enhance critical stakeholder engagement to disseminate TGI information.

### Individual Reviewer Comments

- This project focuses on PV integration from the perspective of transmission rather than distribution system operation. Even though a majority of photovoltaic (PV) systems will connect to the grid at a medium/low voltage distribution level, their aggregated impacts will necessarily become visible at the bulk transmission level. For this reason, the project is relevant to the SunShot program.
- The project's focus on bulk transmission provides balance to the program's portfolio. Working directly with various utilities, such as the Western Electricity Coordinating Council and North American Electric Reliability Corporation, improves the likelihood that the project will have an impact.

- The list of four specific project objectives can benefit transmission system operation across many regions. The approach is reasonable and practical. Overall, the topic of this work is timely, and the topics and results that were presented are of good quality.
- The other topic that was discussed is an optimal stochastic unit commitment/dispatch methodology, which seems to be in an earlier stage of development.
- The funding level seems to be slightly high compared to the levels of other projects in the portfolio.
- As stated in the "Key Findings and Outcomes" section of the technical summary, the project has observed a number of PV characteristics based on simulated data (e.g., larger plants have a reduced risk of excessive ramping), yet there was no attempt to verify or explain the observations.
- It would be beneficial to explain the PV model, including an explanation of model aggregation from distribution systems that are being developed for transmission analysis (e.g., stability and stochastic analysis).

## PROJECT: 25798 SANDIA NATIONAL LABORATORIES

### *Increasing Prediction Accuracy*



**FUNDING INFORMATION** \$4.2M | National Laboratory Research and Development | 10/2009–09/2014

### Project Description

The goal of this project is to quantify and reduce uncertainties in photovoltaic (PV) system performance models by systematically analyzing, quantifying, and propagating uncertainty using research-quality PV monitoring data in various climates, leading the international Photovoltaic Performance Monitoring Collaborative (PVPMC) to standardize and document existing and emerging modeling algorithms, make targeted model improvements for concentrated photovoltaic (CPV) technologies and systems, and develop new methods for extracting more information from PV monitoring systems and data streams.

### Individual Reviewer Comments

- The project is focused on developing PV performance models for PV plants. The team has made very good progress to date. The excellent team is working with the PV community to educate them on PV modelling. Continued funding is essential for transitioning emerging PV technologies to the marketplace.
- The project seems to have a good approach to increasing prediction accuracy—such as making targeted model improvements for CPV technologies and systems—as it is timely and also necessary for industry practice. These predictions must be as accurate as possible in order to minimize finance charges, produce higher accuracy results, and reduce project risk.
- Sandia-led PVPMC has 1000 members and is the core program for coordinating all worldwide PV performance modeling research. This project also includes tasks for addressing the uncertainty of the modeling and defining better ways to collect data and monitor PV performance in the field.

## PROJECT: 25799 SANDIA NATIONAL LABORATORIES

### *Characterizing Emerging Photovoltaic Technologies*



**FUNDING INFORMATION** \$5.1M | National Laboratory Research and Development | 10/2013–09/2015

### Project Description

The Sandia National Laboratories team will focus on developing, improving, and validating characterization methods for photovoltaic (PV) modules, inverters, and embedded power electronics. Characterization methods are at the heart of technology assessments and provide the basis for accurate modeling of components and systems. Outputs of the project include measurement and analysis procedures that industry can use to better distinguish and understand the performance differences between competing module and inverter products and new component designs and technologies, such as new PV cell designs, inverter topologies, and more.

### Individual Reviewer Comments

- The project is focused on improving existing methods and developing new methods for the characterization of PV systems, including inverters, power electronics, and PV modules. The project is very relevant to U.S. Department of Energy goals, and the technical progress has been excellent to date. Continued funding for this project is essential to maturing PV system technologies.
- The proposal objectives, which require developing procedures for calibrating the Sandia PV Array

Performance Model (SAPM) and validating these procedures with industry partners, have been achieved. These results, along with tools that precisely calibrate single-diode performance models, and model improvements for overcoming systematic model deficiencies, will be provided to industry.

- A particularly interesting task is the development of test methods to characterize alternating current (AC) modules that are composed of microinverters. The objective is to find ways to characterize the direct current (DC) module and AC inverter from the single output without accessing the DC terminals. The project is also considering the downstream usage of the characterization results for AC modules in system performance models.
- This project has several tasks that enhance the characterization and modeling of PV systems for emerging technologies. The project is diverse with many dimensions, so each task is assigned to a sub-Primary Investigator. One of its goals is to rewrite the SAPM tool to make it more useful outside of Sandia. Other goals involve updating characterization and models for new technologies.



## PROJECT: 25800 SANDIA NATIONAL LABORATORIES

### *Advanced Measurement and Analysis of PV Derate Factors*



**FUNDING INFORMATION** \$2.6M | National Laboratory Research and Development | 10/2013–09/2015

### Project Description

This project focuses on improving the accuracy and reducing the uncertainty of photovoltaic (PV) performance model predictions by addressing several common elements of all PV performance models referred to as “derates.” Derates are represented by simple empirical factors that are not tied to underlying physical loss mechanisms. There is a significant amount of uncertainty regarding appropriate values for these factors.

### Individual Reviewer Comments

- The project is focused on (1) determining PV performance losses due to soiling/dusting of the panels and (2) predicting mismatch losses and PV performance due to changes in spectral variations with time and seasons. The team has made very good progress to date. Continued funding is recommended.
- The team uses good analysis techniques to detect losses on panels due to soil coverage and outdoor studies

of deposited composition and accumulation rate at geographically distinct locations.

- PV system and all PV performance models, such as the System Advisor Model, use derate factors. An important aspect of the project is to identify the most important spectral bands to monitor with lower cost sensors based on an understanding of the impact of humidity and dust to determine the spectrum in the field as well as the statistical model for string mismatch.
- A method has been developed that accounts for the effects of solar spectrum on PV performance by utilizing a combination of an improved spectral model with one or more low-cost sensors as inputs to the model.

## PROJECT: 25801 SANDIA NATIONAL LABORATORIES

### *PV System Reliability*



**FUNDING INFORMATION** \$4.6M | National Laboratory Research and Development | 10/2012–09/2015

### Project Description

Sandia will conduct research to address widespread reliability and safety issues in today's photovoltaic (PV) systems. Specifically, the team will investigate PV arc- and ground-fault issues and inverter reliability. Arc-fault research and development efforts will assist with the development of arc-fault detector/circuit interrupter certification standards through Underwriters Laboratories task groups and the International Electrotechnical Commission Technical Committee. Inverter reliability efforts will utilize the electro-thermal modeling tool, piecewise linear electrical circuit stimulation, and laboratory and field testing to evaluate and optimize inverter designs to achieve a 25-year inverter lifetime under realistic usage conditions (including advanced inverter functionality, such as Volt-Ampere Reactive support).

### Individual Reviewer Comments

- The project is focused on detecting and mitigating arcs and ground faults in PV systems and determining the reliability of inverters. This project is essential to developing highly reliable PV systems.
- To date, the team has made excellent progress. Continued funding is recommended.
- The project is a good study of the reliability of the PV system. It aims to improve the ability to detect and mitigate arc and ground faults in PV systems by developing codes and standards, and then transferring them to industry. The work is very interesting so far.
- It is suggested that the project coordinate with the National Renewable Energy Laboratory's vehicle work on field inverter testing.

## PROJECT: 25802 NATIONAL RENEWABLE ENERGY LABORATORY

### *Increasing Distributed PV Penetration Levels*



**FUNDING INFORMATION** \$3.7M | National Laboratory Research and Development | 10/2013–09/2015

### Project Description

This project will improve existing utility modeling tools and develop new conversion tools in an effort to improve interconnection screens and studies to assist utilities, photovoltaic (PV) developers, stakeholders, and regulatory agencies. The team will develop Hardware-in-the-Loop methods, create advanced visualization tools, lead the development of interconnection standards and codes, engage with key industry stakeholders—including the Federal Energy Regulatory Commission (FERC) and state Public Utility Commissions—and develop educational materials for utility personnel.

### Individual Reviewer Comments

- The project is highly relevant to the goals of the program. Its focus on both improving screening methods and developing standards for advanced inverter functions may have a large impact on achieving SunShot goals.
- The approach is well suited to developing and propagating new screening methods and inverter standards.
- The National Renewable Energy Laboratory seeks to improve interconnection processes for distributed PV systems through the development and application of modeling tools, study methods, laboratory research and development, and by engaging stakeholders. Eight initiatives are listed in the paper. The key findings that were presented included simulation studies. These studies provided a greater understanding of PV impacts and will lead to new screening methods; advanced inverters; advanced visualization; online training; participation in the Institute for Electrical and Electronics Engineers (IEEE) 1547, 1547a, and 1547.7 activities; stakeholder engagement; data conversion to OpenDSS, and guidance for FERC. These activities promote important and often behind-the-scenes progress that will promote PV installation.
- The funding level is modest, given the scope of work.

## PROJECT: 25803 NATIONAL RENEWABLE ENERGY LABORATORY

### *Solar Value Analysis and Market Penetration Modeling*

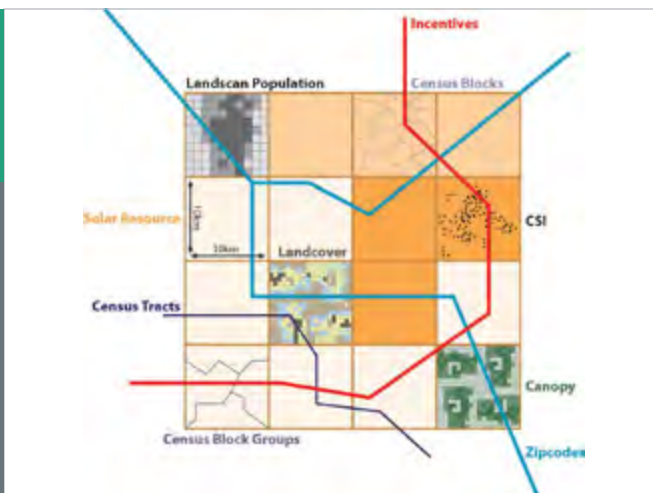

**FUNDING INFORMATION** \$3.4M | National Laboratory Research and Development | 10/2012–09/2015

### Project Description

This project will help implement a comprehensive framework for characterizing solar, technical, and economic potential. It will also represent solar technologies in capacity-expansion models by conducting foundational model development and analysis activities. The results from this project will improve upon existing modeling efforts in both utility-scale (wholesale) markets and distributed (retail) markets. They will also continue to evaluate the interaction between these two market sectors. In the utility sector, the proposed research will further evaluate key drivers of economic competitiveness. These include solar prices, local solar resources, electric-sector market dynamics (e.g., load growth, regional renewable portfolio standards and other policies, the existing mix of conventional generation resources and transmission infrastructure, fuel prices, and retirements of conventional generators), the value of solar generation (e.g., solar capacity value, the impact of solar variability on the need for additional operating reserves, and the change in these factors with increasing solar deployment), project-level investor risk, and several other factors. In the distributed photovoltaic (PV) sector, the proposed research will continue ongoing analysis of the retail value of PV, including, for example, how customers weigh the costs and benefits of PV ownership. Filling this gap will help to inform the development of policies aimed at encouraging the type of solar market growth envisioned under the SunShot Initiative.

### Individual Reviewer Comments

- This project focuses on the modeling and analysis of PV from PV-sector and utility company perspectives in the context of economic competitiveness and financial/business value propositions. It is a good complement to the other technical projects.

- Economic viability is the key to PV development. This project is relevant and can lead to important impacts for utility and non-utility organizations alike. The third party ownership model, for example, is a good scenario that this project examines.
- The project is relevant to several areas, such as improving the modeling of distributed PV, linking the National Renewable Energy Laboratory's (NREL) capacity expansion model to production cost models, and examining the portfolio value of solar in different market structures.
- The project's findings could have an impact on SunShot goals by helping utilities and market participants better understand various technology and market structure scenarios.
- The project's approach seems to be reasonable for its multiple research goals. This project consists of four synergistic research tasks: (1) distributed PV modeling and analysis, (2) utility-scale solar modeling and analysis, (3) solar project risk and portfolio analysis, and (4) general solar analysis. Thirteen publications have been reported for the project in FY 2013 and the first half of FY 2014 in five journal papers and eight NREL reports. The thrusts of the research project are of interest, but the techniques were not always clear. The accurate assessment of the full range of economic implications of high-penetration PV is important.
- The funding level is relatively higher than that of other modeling projects in the Systems Integration portfolio.
- While a majority of PV systems are connected to the distribution system, the benefits of PV are not limited to retail market transactions.

## PROJECT: 25805 NATIONAL RENEWABLE ENERGY LABORATORY

### *Transmission and Alternatives Analysis and Strategic Stakeholder Engagement*

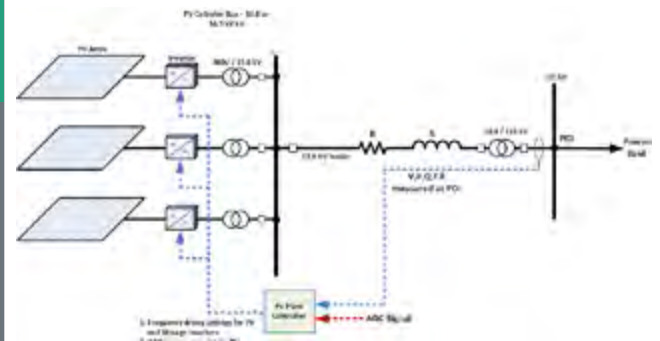

**FUNDING INFORMATION** \$2.1M | National Laboratory Research and Development | 10/2012–09/2014

### Project Description

During this project, the National Renewable Energy Laboratory (NREL) will examine the Western Interconnection large-scale stability and frequency response under high solar and wind penetration. It will also identify the means to mitigate adverse performance impacts via transmission reinforcements, storage, advanced control capabilities, or other alternative means. The second activity is to improve the understanding and better utilization of advanced PV controls through field testing and demonstration on a real utility-scale photovoltaic (PV) plant via a partnership with a collaborating energy industry member. To accomplish this goal, NREL will identify a potential partner(s), establish a technical review committee, develop and implement a detailed scope of work, and test plan for a field project to demonstrate the grid-friendly capabilities of utility-scale PV power plants. The third activity is to create a validated, flexible, three-phase, cycle-bicycle model of PV inverters and PV plants and their associated controls in the Power System Computer Aided Design program, which is both well established and fully supported. The proposed model is generic and open source in nature, easy to modify for different implementations by different manufacturers, and will accommodate future enhancements that are required by the regional reliability organization or local utilities as the solar PV penetration increases. NREL will communicate the tools, methods, and results from grid integration research to targeted stakeholders. The goal is to engage the utilities, regulators, policymakers, and organizations that establish the reliability and operational rules to ensure that they have the tools and data needed to study high solar penetrations

and understand the reliability and balancing impacts of solar. This effort involves a threefold strategy: (1) participation in utility forums and the Utility Variable Generation Integration Group; (2) participation in technical committees; (3) engagement with regulators, policymakers, and other key stakeholders; and (4) provide specific technical support and input to the transmission planning process in the Western Interconnection.

### Individual Reviewer Comments

- This project covers several activities that involve a close working relationship with utility organizations. Collectively, they build technology and business practices to facilitate improved PV integration. The development of a composite model of load and distributed energy resources is a critical function, as it addresses the challenge of transmission and distribution model integration. Going from zonal to balancing area is an important step that highlights the need for an accurate (often more granular) model for distributed energy resources.
- The project's objectives are highly relevant to the System's Integration activity area. The project explores several important lines of research and could have a substantial impact in a number of areas. The approaches for each subtask seem well suited to meeting the project objectives.
- The funding seems to be quite modest, given the ambitious range and depth of activities the project team is pursuing under this award.

- This project involves several initiatives related to utility-scale PV power plants. The poster discusses the Western Wind and Solar Integration (WWSIS) Phase 2 results that were reported in FY 2013, and the WWSIS Phase 3 study that is ongoing. These studies on integrating wind and solar resources on the Western Interconnection are worthwhile.
- Other areas that were reported are the development of a standardized transient model of a PV inverter for use with the Power System Computer Aided Design software and the planning for a utility-scale PV plant demo that will investigate a variety of operating modes that are not currently in use or allowable. These tasks are worthwhile, and the results reported in the WWSIS Phase 2 study are of interest.
- In the PV plant demonstration activity, assuming that the plant is a virtual collection of multiple PVs, it would be beneficial to consider the presence of aggregators. Industry experiences in aggregated demand response operation (e.g., the Electric Reliability Council of Texas and Pennsylvania-Jersey-Maryland) should be leveraged.

## PROJECT: 25807 NATIONAL RENEWABLE ENERGY LABORATORY

*Operational Analyses, Models, and Tools Improvement*



**FUNDING INFORMATION** \$3.5M | National Laboratory Research and Development | 10/2012–09/2015

### Project Description

This project consists of multiple activities conducted by National Renewable Energy Laboratory (NREL). The first activity is a study that analyzes the impact of large-scale deployment of wind and solar in the Eastern Interconnection of the United States. The Eastern Renewable Generation Integration Study analyzes 2 strategies for reaching 30% of the combined wind and solar targets, and informs stakeholders about the operational impacts of these 2 strategies. The second activity analyzes the optimal method for operating reserve requirements with high solar penetrations. The first objective is to improve a software tool that models both the holding and deployment of reserve capacity to be used by a large system operator. The second objective is to understand the nontraditional factors that influence the need for operating reserve and compare how these should contribute to optimal operating reserve requirements for a balancing area. The third activity is to examine in detail the value proposition for concentrated solar power (CSP) technology, focusing on the implementation and use of CSP with thermal energy storage. NREL will evaluate the ability of CSP to provide dispatchable energy, firm system capacity, and ancillary services. Further, the value of CSP will be compared to other sources of system flexibility, especially in enabling higher penetrations of variable generation resources, such as photovoltaics (PV). The final activity in this project is to create a new national solar database with higher temporal and spatial resolution, and provide public access to this data to reduce the costs and risks of integrating solar power systems into the electric power grid.

### Individual Reviewer Comments

- The project has separate components dealing with PV data, modeling, and integration issues. The work on the sub-hourly reserve is particularly important.
- The project covers several activity areas that are relevant to the program's objectives. The project may have a significant impact on improving solar economics by reducing reserve requirements to support renewable integration, making high-resolution irradiance data publicly available, and advancing an understanding of the economic value provided by CSP and thermal energy storage. The team has developed a sound research plan to achieve the project objectives.
- The funding level seems to be modest, given the scope of the project activities.
- The sub-hourly study results conclude that variable renewable generation causes an increase in reserve requirements, and that some current tools may overestimate this increase, while others may underestimate it.
- The solar integration national dataset aims to develop a stochastic predictive model of PV generator output investigating both one-minute and four-second data predictions. The goals of these thrusts seem to be worthwhile, though it is not clear from all of the tasks how these results advance previous knowledge.
- The comments in the "Key Findings and Outcomes" section could be more insightful.

## PROJECT: 25808 NATIONAL RENEWABLE ENERGY LABORATORY

### *Core Competencies for Solar Resource Assessment*



**FUNDING INFORMATION** \$3.3M | National Laboratory Research and Development | 10/2012–09/2015

### Project Description

The Core Competencies for Solar Resource Assessment project aim to improve the tools and methods for measuring solar radiation, thereby reducing uncertainty in predicting solar output and improving the bankability of financing solar projects. This project has three tasks that conduct research on advancing solar resource measurements: Task 1) broadband and spectral calibration and measurement, Task 2) continue developing the National Solar Radiation Data Base, and Task 3) standards and expert committees. Task 1 is focused on reducing spectral and broadband solar measurement uncertainty through improvements in instrumentation, calibration, and cross-comparison. The National Solar Radiation Data Base (NSRDB) is the most widely used public solar radiation database in the United States. In Task 2, the NSRDB will be updated with high-resolution, satellite-based solar radiation datasets that are created using a state-of-the-art physical model, thereby providing users with a lower uncertainty, higher-resolution dataset. Finally, in Task 3, an international consensus on standards in solar measurement and modeling will be developed to represent state-of-the-art knowledge through the continuous formal engagement of various stakeholders (e.g., through the participation of the American Society for Testing Materials International in the development of radiometric standards).

### Individual Reviewer Comments

- The project description shows three major thrusts: solar resource measurement and characterization, development of best practices for solar radiometry, and dissemination of solar resource information. The maintenance of calibration that is traceable to the World Radiometric

Reference is important, as is the program, in order to provide calibration to organizations throughout the United States.

- The program maintains a database of solar radiation that is a widely-used, valuable resource. The measurement and instrumentation scope of the project provides narrow, yet fundamental technology for the program.
- In light of its focus on improving the measurement of total annual irradiance, the project does not seem particularly relevant to the goals described in the “Grid Performance and Reliability” activity area, but could arguably fall within the scope of the “Plant Performance and Reliability” activity area. However, the project could have a substantial impact on improving total annual output estimates.
- The funding level is quite reasonable, given the scope of the project, and the approach seems likely to achieve the stated goals. The United States, including the U.S. government, needs to be well represented in the development of consensus solar radiation standards. It is important that a steady source of funding be found for this work.
- The site would be improved with a concise user’s guide, specifically for photovoltaic farm designers.



## PROJECT: 25809 NATIONAL RENEWABLE ENERGY LABORATORY

### *Emerging Technology Characterization*



**FUNDING INFORMATION** \$3.0M | National Laboratory Research and Development | 10/2013–09/2015

### Project Description

The National Renewable Energy Laboratory will conduct research to remove barriers that are due to the uncertainties associated with the performance of emerging technologies. The emerging technologies that are addressed are thin film and concentrating photovoltaic (CPV) modules. The team will develop procedures to stabilize the performance of thin-film PV modules copper indium gallium selenide and cadmium telluride for measurement of performance at Standard Rating Conditions. The team will also develop and validate testing methods to determine outdoor power ratings of CPV modules and reduce uncertainty from plus or minus 10% to plus or minus 5%.

### Individual Reviewer Comments

- The project is aimed at developing methods to characterize emerging PV technologies, such as thin-film PV modules and CPV modules. In addition, they are developing data that are required for performance modelling. The team has made very good progress to date.
- Continued funding is essential for transitioning emerging PV technologies.
- The project's proposal objective of developing methods to address the meta-stabilities of polycrystalline thin-film PV modules for measuring their peak power with solar simulators has been successfully met.

## PROJECT: 25810 NATIONAL RENEWABLE ENERGY LABORATORY

### *Quantifying Risk through Bankability Reports and Standards*

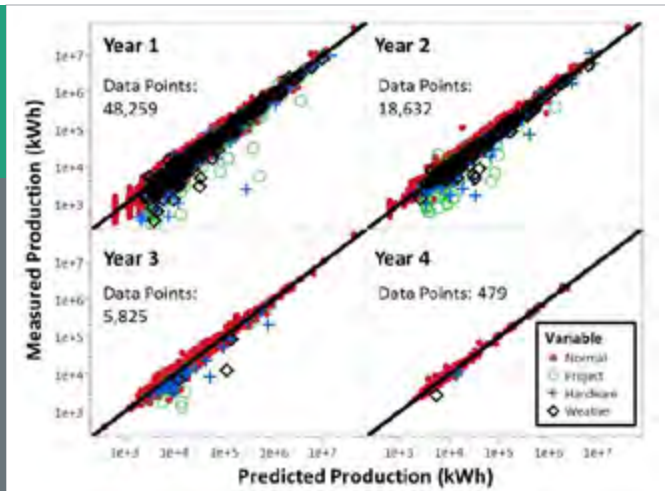

**FUNDING INFORMATION** \$2.8M | National Laboratory Research and Development | 10/2013–09/2015

## Project Description

The National Renewable Energy Laboratory (NREL) is focusing on the technical details of assessing photovoltaic (PV) performance risk with the goal of reducing risk (both actual and predicted) and decreasing the time and cost that are needed to assess this risk. To this end, NREL is developing standards to quantify PV performance, documenting actual PV performance versus predicted performance across large data sets (50,000 or more), and documenting and standardizing the quantification of degradation rates.

## Individual Reviewer Comments

- The objective of the project is to develop tools to characterize the energy that field PV systems produce and establish degradation rates. This work is essential to improving the bankability of the PV systems.
- The Principle Investigator appears to be very knowledgeable and motivated. The project aim is to improve PV performance on a broad scale and develop tools to characterize produced energy as well as module

degradation rates. More specifically, the work is focused on a dataset for nearly 50,000 systems. It is also focused on the development of energy tests for both PV and concentrated PV systems. For example, tests were performed on inverter components, such as insulated-gate bipolar transistors and thin-film capacitors. Their performance was determined and their models were created in Piecewise Linear Electrical Circuit Simulation software. The project's progress has been satisfactory.

- This project is closely coordinated with the other projects.
- The bankability reports address many aspects. Recovery Act data are unique in that they give broad, rather than single, vendor proprietary data. The modules are living up to their expectations.

## PROJECT: 25811 NATIONAL RENEWABLE ENERGY LABORATORY

*Improvement and Validation of Solar Systems Modeling Algorithms and Tools*

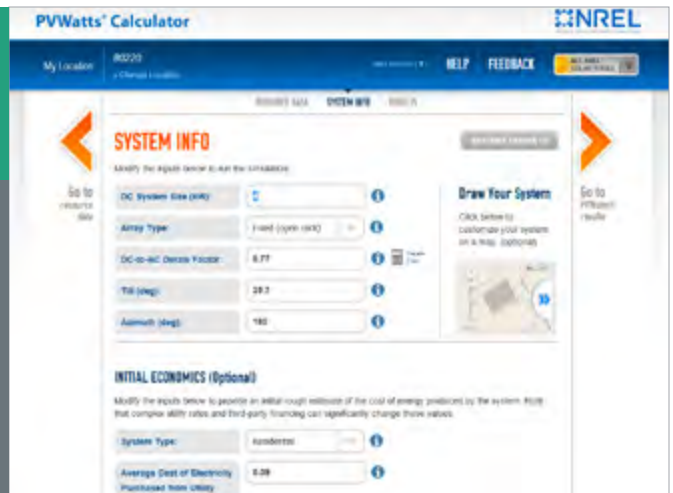

**FUNDING INFORMATION** \$3.1M | National Laboratory Research and Development | 10/2013–09/2015

### Project Description

The project team aims to improve system modeling accuracy and risk assessment by researching improved data and algorithms, making robust models available to the photovoltaic (PV) industry, and improving the characterization of risk and bankability across all markets (residential, commercial, and utility). The project's ongoing value to the community is to enable and accelerate the research and analysis of solar technologies through the development and dissemination of cutting-edge solar and finance modeling through desktop tools, software engines, and web services, such as the System Advisory Model (SAM) and PVWatts.

### Individual Reviewer Comments

- The project is focused on the development of solar array performance and finance modelling tools. The team is making very good progress. This work is very essential for transitioning solar technologies to widespread deployment in the United States.
- This is a necessary software program to predict the system's cost from a financial point of view.
- Proposal objectives are successfully being met.
- The program includes weather data; its outcomes and results are being compared against the test data. SAM planning, including financial aspects, uses standard weather data formatting.

## PROJECT: 25812 NATIONAL RENEWABLE ENERGY LABORATORY

### *Predicting Service Life for PV Modules*



**FUNDING INFORMATION** \$9.9M | National Laboratory Research and Development | 10/2013–09/2015

### **Project Description**

The National Renewable Energy Laboratory (NREL) is developing a set of accelerated stress tests that can provide quantitative predictions of module service life in a variety of climates for different photovoltaic (PV) technologies and applications. The developed accelerated stress tests will be incorporated into a set of standards.

### **Individual Reviewer Comments**

- The major objective of the project is to develop accelerated stress tests that can provide a semi-quantitative prediction of module service life in a variety of climates for different PV technologies. The tests that are being conducted include ultraviolet (UV) tests. This project is essential to guiding the development of long-life and highly reliable PV systems.

- The PI and the team are very knowledgeable and experienced.
- Tests are being performed on modules, and techniques for accelerated testing are being developed. These accelerated tests are mainly geared toward modules. UV, thermal, and discoloration tests are being performed. The NREL team needs to conduct testing for all types of modules.

## PROJECT: 25813 NATIONAL RENEWABLE ENERGY LABORATORY

*International Electrotechnical Commission and National Electric Code PV Standards*



**FUNDING INFORMATION** \$2.0M | National Laboratory Research and Development | 10/2013–09/2015

### Project Description

The National Renewable Energy Laboratory aims to provide technical validation to reduce the uncertainty in predictions of photovoltaic (PV) performance, quality, safety, and product lifetimes in order to differentiate technologies and products and set baselines for product improvement and investment. This is accomplished by continuing U.S. Department of Energy representation and participation in several standards and codes activities to ensure that the best technical work is available in the areas of PV measurements, and that testing is turned into standards and codes. Particular attention is paid to the International Electrotechnical Commission (IEC), the National Electric Code (NEC), and various building codes to support codes that facilitate the growth of PV and avoid codification of requirements that unfairly or inaccurately limit the implementation of PV.

### Individual Reviewer Comments

- The project is highly relevant to the Plant Performance and Reliability activity area. By working directly on setting codes and standards based on the best and most current analysis, the project can have a substantial impact on facilitating the adoption of solar PV.

- Standardization work is essential for PV to mature into viable business. Participation in international standards organizations such as the IEC is important.
- The funding level is suitable to the project's scope, and the approach seems to be focused and well thought out. However, in general, the funding for standards work should be more continual versus competitive.
- This project supports participation in the IEC, NEC, and building and fire codes that are applicable to PV. It is important that appropriate standards keep abreast of technology development. Further, it is important for the United States to be well represented in the development of international standards. There should be a long-term commitment of support for these efforts.

## PROJECT: 26184 NATIONAL RENEWABLE ENERGY LABORATORY

### *Solar Resource Modeling and Measurement Research*

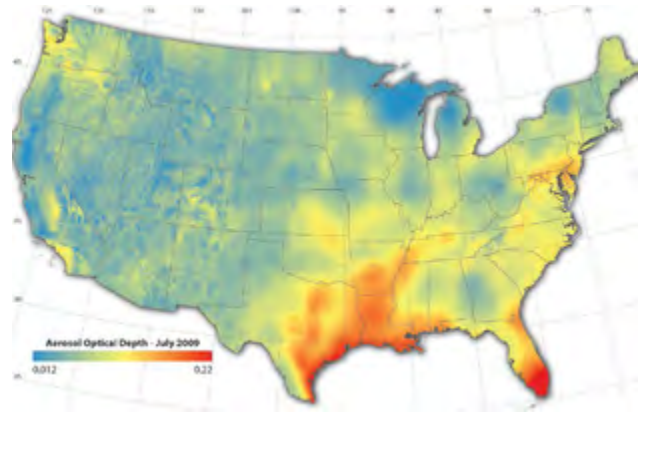

**FUNDING INFORMATION** \$2.3M | National Laboratory Research and Development | 10/2012–09/2015

### Project Description

The Solar Resource Modeling and Measurement Research project aims to improve the tools and methods to measure solar radiation, and, therefore, reduce the uncertainty in predicting solar output and improve the bankability of financing solar projects. This project has two tasks that conduct research on advancing solar resource measurements: Task 1) satellite-based modeling and validation and Task 2) photovoltaic (PV) system-derived data. In the first task, the advanced Geostationary Operational Environmental Satellite Solar Insolation Product Project seeks to advance the state of the art in satellite-based solar resource assessment and reduces the uncertainty of the solar resource data through improvements in the physics of the resource assessment method. The cost associated with conventional measurements of solar radiation using thermopile instruments prevents wide-scale measurement of the solar resource. Therefore, in the second task, the goal is to develop and validate cost-effective instruments and methods for gathering solar radiation data, which will facilitate improved ground-based solar resource data availability.

### Individual Reviewer Comments

- The project has well-defined project objectives. The “bankable” datasets are important, and efforts are well directed toward meeting the project goals.
- Temporal and spatial characterizations are very useful. The funding level seems to be appropriate for the scope of work that is involved. The team’s approach to improving the datasets is suitable for achieving the project goals.

- The project’s research tasks are highly relevant to solar resource modeling. The successful conclusion of the project could provide higher resolution solar data that would facilitate planning for the increased penetration of solar PV.
- The poster discusses the need for accurate and readily available public solar resource datasets and tools. The method under study, here, is to develop a method that uses satellite data to provide these datasets. The validation of the satellite data is underway. If the satellite data can be validated, the gathered data will go into published datasets, such as the National Renewable Energy Laboratory Solar Prospector site.
- The presentation clearly describes what is being done, but it is not always so clear in describing why this needs to be done, apart from the overall goal of improving the data that is used for PV performance studies. It appears as though this dataset will be most useful for site planning studies. It would be useful to clarify why the yearly databases that are currently available are not sufficient for these long-term needs.

## PROJECT: 27378 SANDIA NATIONAL LABORATORIES

### *Module Level Power Electronics Reliability and Accelerated Testing Standards*



**FUNDING INFORMATION** \$1.4M | Physics of Reliability: Evaluating Design Innovations for Component Technologies in Solar | 10/2013–03/2016

### Project Description

Sandia leads the collaborative development and initial implementation of industry-standard tests for module-level power electronics reliability in stand-alone and module-integrated configurations. Test development will utilize a sound, physical understanding of failure mechanisms and degradation modes, with the incorporation of extensive laboratory and field testing to validate the tests and test protocols that are developed, and to ensure broad applicability across the industry.

### Individual Reviewer Comments

- This seems to be an interesting and timely project that focuses on determining the reliability of power electronics at the module level. Inverters that are large (~500 kilowatt), small, and modular, as well as module-level (~200 Watt) power electronics are being tested. Microinverters and direct current power optimizers offer advantages in safety, system operations and maintenance, energy yield, and component lifetime due to their smaller size and lower power; however, they also suffer from array topology. Field and in-house tests were used to generate reliability metrics and standards through working groups.
- The project is focused on developing accelerated life tests for module-level power electronics/microinverters. A working group with 25 members was established to collect data for model development. The team has made good progress to date.
- The team is pushing to move to microinverters for the residential sector. This involves a consortium of microinverter manufacturers. This goes beyond qualification and into reliability.

## 255797 SANDIA NATIONAL LABORATORIES

*Advanced Solar Resource Modeling and Analysis*



**FUNDING INFORMATION** \$1.2M | National Laboratory Research and Development | 10/2012–09/2015

### Project Description

The dominant contribution to uncertainty in projected power and energy from solar arrays arises from uncertainty in the estimated solar resource. Uncertainty in estimated irradiance stems from uncertainty in the models that translate satellite measurements to estimated irradiance; portray the spatial and temporal variation in irradiance over a power plant's footprint or over a fleet of solar power systems; and separate global horizontal irradiance into its beam and diffuse components. This project performs research and development, which leads to improved models that can reduce these uncertainties, and, thus, lead to reduced financial and technical risk to solar power deployment. The key activities for this project are: improve irradiance that is estimated from satellite data through extensive validation of the emerging Global Solar Insolation Project's global horizontal irradiance (GHI) and direct normal irradiance (DNI) estimates; improve upon current methods to represent the geographic smoothing of irradiance over the spatial extent of utility-scale power plants, as well as over fleets of solar power systems; provide guidance for the number of sensors that are required for accurate spatial irradiance measurement; and improve models that estimate DNI direct normal irradiance and plane-of-array (POA) irradiance from the GHI.

### Individual Reviewer Comments

- The topic of the research is both timely and necessary. The research approach is logical and should produce results.
- Improving the modeling of irradiance, especially at greater levels of granularity, is very relevant to the goals of the program. If successful, the project could have a substantial impact on improving the accuracy of predicted output.
- The foci of this project are to improve solar irradiance forecasting through enhancements in irradiance estimates from satellite data, smooth irradiance over geographical locations, and translate irradiance data to DNI and POA. The work is relevant to U.S. Department of Energy program objectives because this project serves a critical link in the efforts to improve solar production forecast.
- In the first year of the project, a new irradiance model was developed and reported. The project is currently assembling a database of ground measurements that will be used for model validation.
- A better understanding of the performance metrics for irradiance forecasting in the context of the power system end users would be helpful.



## TECHNOLOGY TO MARKET

The SunShot Incubator program, which began in 2007, is now in its ninth round. Recipients, who graduate from the program within 12–18 months, have attracted outstanding levels of private follow-on funding relative to federal investment. Tightly formulated commercial and technical deliverables are the cornerstone of the program. The program also boasts breadth and permanence; the solicitation is open to a wide range of topics and recurs annually, subject to appropriations. The Small Business Innovation Research and Small Business Technology Transfer (SBIR/STTR) are congressionally mandated programs that, although not entirely managed from within SunShot, serve the purpose of piloting topics and concepts that complement the rest of the SunShot portfolio. SunShot aims to select and support Incubator and SBIR/STTR recipients whose innovative ideas will continue to benefit the solar market. The program goal is to have at least 50% of recipients and/or their business solutions survive and have impact in the marketplace beyond 2020.

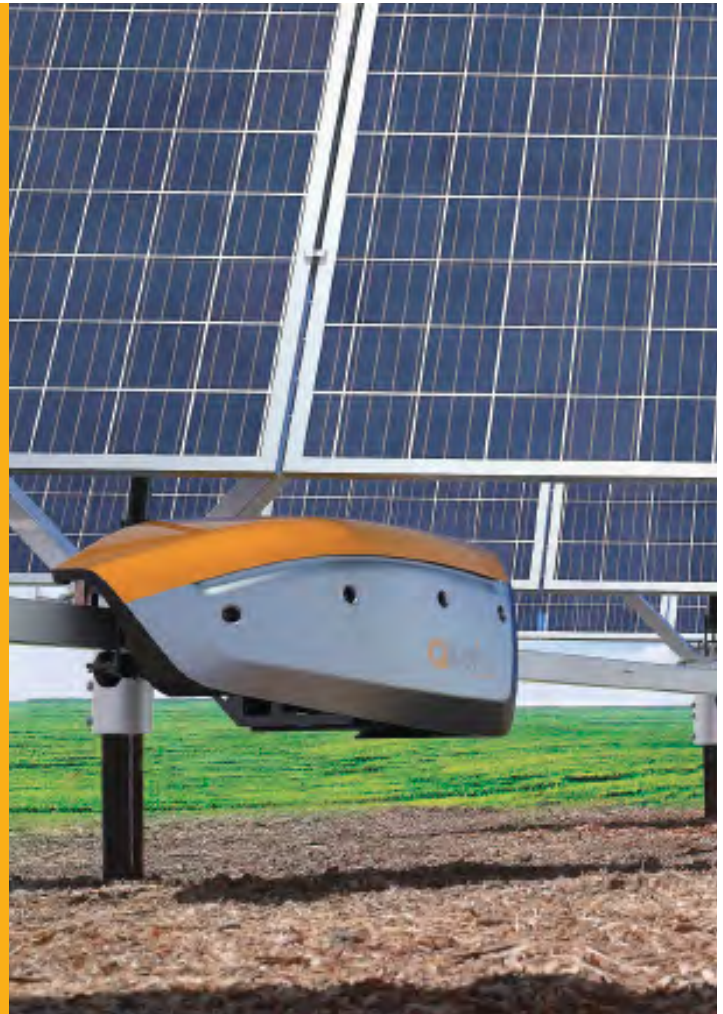

Incubator awardee QBotix has developed a robotic tracking system that increases solar PV power plant production by up to 45% and delivers cost savings up to 20%.

## T2M Overview

Dramatic reductions in the cost of solar will enable the high-penetration deployment of solar energy technologies. It is then essential, but insufficient, to discover new materials, build first-of-a-kind devices, or identify that we must simplify PV interconnection backlogs. To have real impact, we must also transition all of these solutions to the marketplace. As a taxpayer-funded program, the SunShot Initiative also aims to create domes-

tic jobs through commercial activity in the solar sector. The Technology to Market (T2M) program builds on SunShot's record of enabling groundbreaking devices and concepts in earlier stage programs with follow-on funding. Technology to Market targets two known funding gaps in bringing new technologies to market: the ones that occur at the prototype commercialization and commercial scale-up stages, as illustrated in Figure 13.

Figure 13: Commercialization and scale-up funding gaps addressed by SunShot’s Technology to Market program

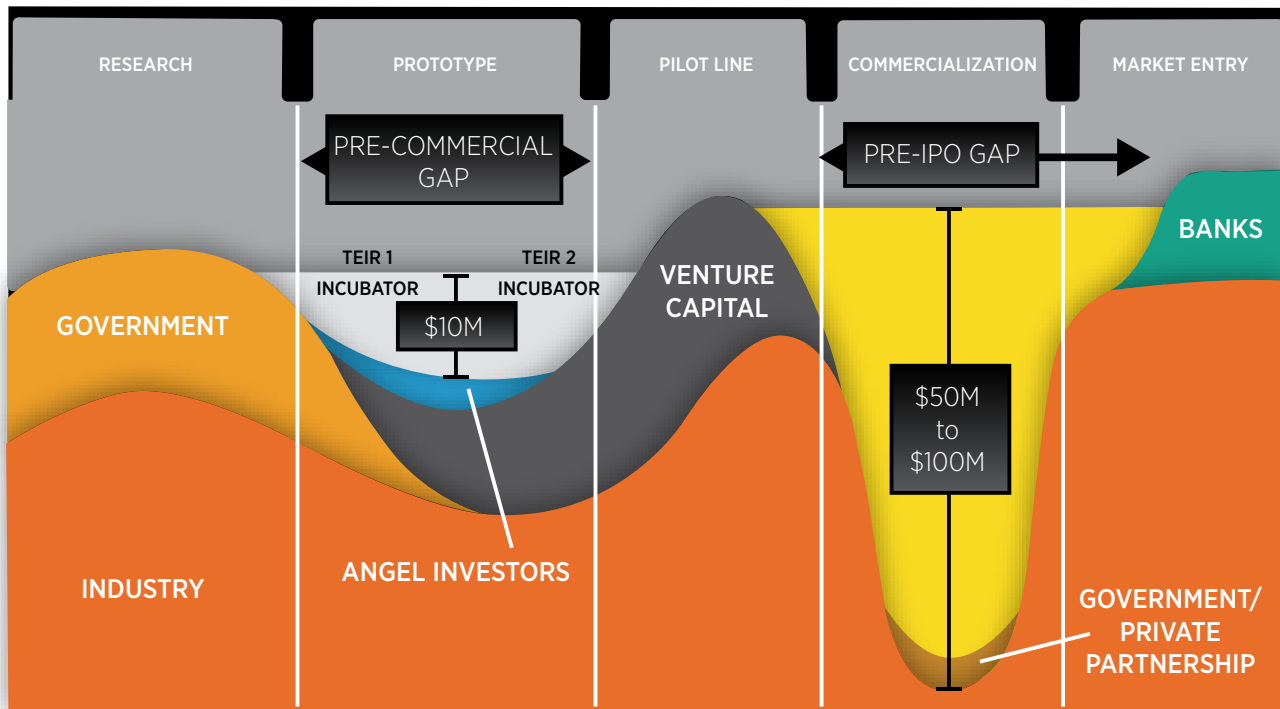

Commercially focused technologies and business solutions in the SunShot portfolio are nurtured across varying stages in both the Incubator program and in the ongoing SBIR/STTR programs. Businesses with later-stage technologies can apply for manufacturing programs such as Solar Manufacturing Technology (SolarMaT) and Scaling

Up Nascent PV at Home (SUNPATH), both of which support cost-effective, domestic, manufacturing pro-

cesses. If typically suitable, manufacturers and component suppliers can also join the consortia funded under the Photovoltaic Manufacturing Initiative (PVMI). All Technology to Market programs are tightly structured to ensure that recipients commercialize the funded technology and achieve technical milestones. Through various other activities, SunShot’s T2M program creates venues for helping the recipients find non-U.S. Department of Energy follow-on funding and form strategic partnerships.

The flagship program in the T2M portfolio is the SunShot Incubator program, currently in its ninth round. In addition to funding commercialization-stage activities and beyond, Technology to Market tends to the internal compass of the SunShot Initiative by supporting market and cost analysis. This analysis informs SunShot's strategic direction and reveals the market barriers that can be addressed through solicitations. On an ongoing basis, SunShot closely scrutinizes the progress of its projects and programs and evaluates internal decision-making with reference to bottom-up cost analyses. These analyses—crucial to a rapidly evolving industry—address conversion technologies and systems, as well as supply chain- and location-specific competitive advantages.

Past recipients have attracted more than \$18 in follow-on funding for every \$1 in federal investment. The Incubator program supports small businesses seeking to commercialize innovative PV and CSP device concepts and manufacturing pilot lines, as well as innovations in hardware installation, grid conversion technologies, and novel business models and software platforms for reducing soft costs.

The programs described below fall into three thematic areas across the T2M portfolio: Technology Commercialization and Business Innovation, Manufacturing Innovation and Scale-Up, and Cost Analysis.



**Dr. Lidija Sekaric**  
*Technology to Market*  
*Program Manager*  
 Solar Energy  
 Technologies Office  
 U.S. Department of Energy

### Team Members

Monica Andrews, SETA  
 Michael Bolen, SETA  
 Doug Hall, Technology Manager  
 Victor Kane, Technology Manager  
 Scott Morgan, SETA  
 Garrett Nilsen, SETA  
 Daniel Stricker, Technical Project Officer

## T2M Portfolio Review Average, Range, and Standard Deviation

Of the 251 projects in the SunShot Portfolio, 44 projects were reviewed as part of the Technology to Market portfolio review. Each reviewed project is listed in Table 10. Projects were ranked on a 1–5 scale, with “1” being the lowest possible score for a category and “5” being the highest score. Reviewers provided overall ratings on each project's relevance to the SunShot and T2M portfolio mission and goals, overall impact, level of funding, and approach taken.

For the T2M portfolio, the overall average rating for a project was 3.47. Of the 44 projects, 23 were performing above the mean, while 21 achieved scores that were lower than the 3.47 average. The range of overall scores was 2.25, with a median of 3.50, mode of 3.75, and standard deviation of 0.51. Overall, the data have a skewness of -0.31 and are skewed to the left, as the mean is slightly smaller than the median, and the median is smaller than the mode. This information is presented in Table 9 and Figure 14. The reviewers' comments on the program as a whole are provided in the following sections.



Art Institute of Chicago, 130.6 kW PV system  
 Photo credit: Spire Solar Chicago

**Table 9: Technology to Market Portfolio Review Average, Range, and Standard Deviation**

	Average	Range	Standard Deviation
Relevance	3.80	2.67 - 4.67	0.58
Impact	3.26	1.33 - 4.50	0.70
Funding	3.34	2.00 - 4.50	0.55
Approach	3.48	1.67 - 5.00	0.74
Overall	3.47	2.17 - 4.42	0.51

**Figure 14: Frequency of overall project rating for Technology to Market portfolio**

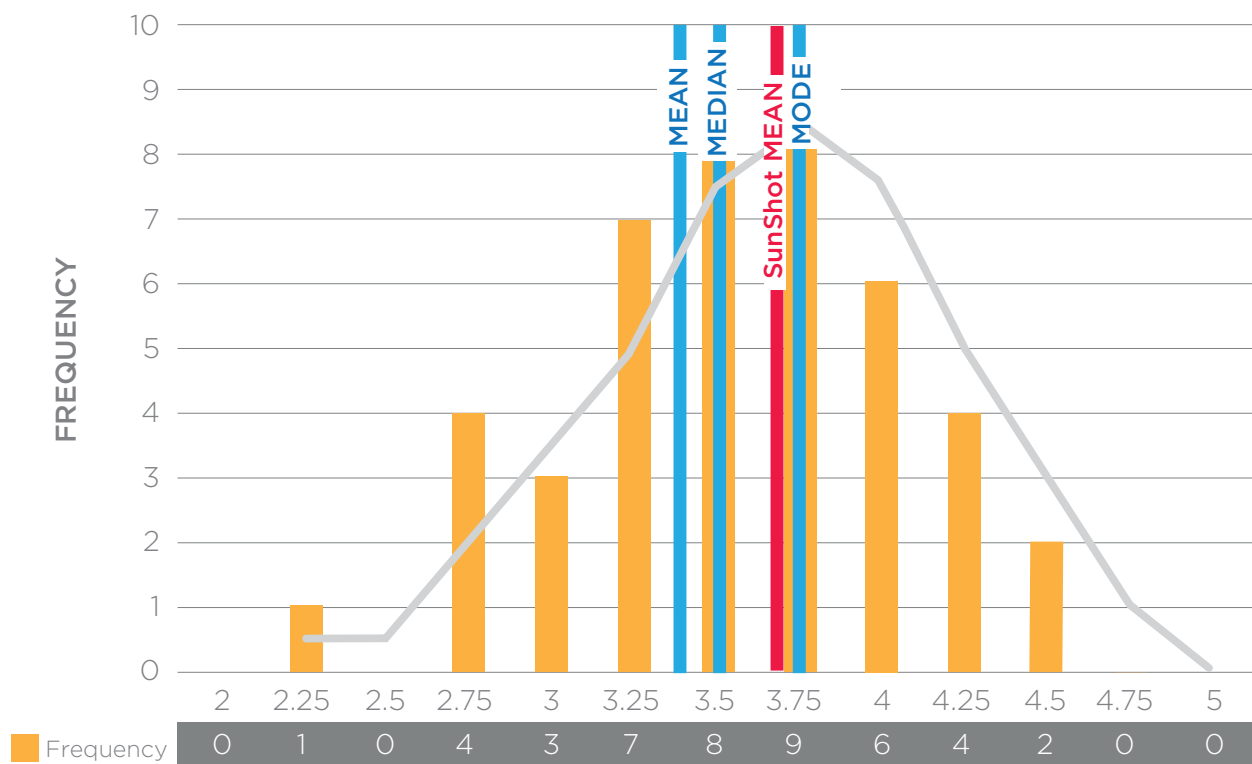

## T2M Portfolio Reviewer Report

The following section contains the evaluation of the T2M portfolio, as analyzed by the reviewers assigned to the portfolio. To preserve the integrity of the reviewer’s responses, the analysis is provided almost verbatim, with minor edits for grammar.

### Quality and Impact of the Portfolio

The quality of work performed by teams in the Technology to Market project portfolio is generally disappoint-

ing, though there are some projects that were very good. To improve this, the U.S. Department of Energy (DOE) should consider being the interface between technology and business development, using benchmarks in industry to guide processes and funding related soft-cost projects. The portfolio should also determine whether or not acquisition should be a goal given that this is “technology to market” and projects seemed to be focused on acquisition.

The cadmium telluride thin film solar cells work at the University of Toledo is one of the encouraging projects as the project team has a good approach and niche market which is key to success. The approach taken by the University of Toledo team should be encouraged throughout the T2M program.

Conversely, there are several underperforming projects in the portfolio. There is a lack of balance between funding for consumer websites, and, more often than not, projects did not present helpful data (e.g., applicability, progress and expected results, cost details, and business models), which made it difficult to discern actual progress versus what project presenters said they would deliver. There is concern that longevity will be a problem for projects in the portfolio. Specifically:

- Applied Materials, Inc. has sold two of its tools and has consequently experienced a level of success, but there is concern as to where the tools went.
- Though the Bay Area PV Consortium has a strategy, the consortia projects have generally been underwhelming and seem to serve as an intermediary between DOE and researchers. The two projects that have the most room for improvement include those being conducted by the U.S. Photovoltaic Manufacturing Consortium (PVMC) and the State University of New York (SUNY).
- The SMASHsolar incubator project is in an early period of performance but appears that it will face two valleys of death.

DOE should consider reevaluating milestones as they did not seem to be the most appropriate for the program. Rather, benchmarks in industry are needed in order to guide the process. This will also help give reviewers a better understanding of what happens after a project ends.

## Appropriateness of Funding Relative to Program Goals

The following project areas are not funded sufficiently in the current project portfolio:

- Economic analysis activities being performed at NREL
- PV system performance by kWh Analytics
- Inverter technology development activities
- Energy storage technology development
- Business development activities and soft costs.

Conversely, several projects were identified as likely having too much funding. Projects in that category include:

- Consumer software development activities
- New cell development activities being performed by Applied Novel Devices, Inc.
- Sun Number which has provided no validation despite more than \$1 million in funding
- Projects in the SUNPATH portfolio that were overwhelmingly vague on metrics
- Consortium activity taken on by SUNY that could be functional with only funding from New York.

## Future Direction and Composition of Portfolio

In general, this project portfolio needs a clearer link to the market as many of the projects are focused only on the technology component and should be moved to a portfolio that is more focused on R&D activities. This could be attributed to DOE expertise being in the science realm as opposed to that of business development which is critical for this program. To help in the future, DOE should consider consulting with venture capitalists when developing funding opportunity announcements in the future to ensure that the business development and market components are adequately accounted for in projects in the future.

Table 10: Projects Reviewed under Technology to Market Program

Award Number	Project Name	Project Organization
4736	Glass Innovations for Improved Efficiency Thin Film PV	PPG Industries, Inc.
4737	Reduced Cost and Manufacturing Complexity of High-Efficiency IBC Solar Cells Using Ion Implantation and In-Situ Patterning	Applied Materials, Inc.
4739	Ultra-Barrier Top Sheet for Flexible PV	3M Company
4946	Bay Area Photovoltaic Consortium	Stanford and University of California-Berkeley
4947	U.S. Photovoltaic Manufacturing Consortium	PVMC Inc.
4948	Solar Rochester	College of NanoScale Science and Engineering, State University of New York
5737	Project Silicon: Reclaiming U.S. Silicon PV Leadership	1366 Technologies
5738	Large-Scale Commercialization of Dilute Nitride Triple Junction Solar Cells	Solar Junction
5739	SANFAB	Soitec Solar Industries
5835	Crowd-Funded Solar Projects	Mosaic
5977	Scale-Up and Optimization of CIGS Tandem Module for Production Readiness	Stion
5982	Production-Ready Dish-CPV Generator	REhnu
6037	Deploying Low-Cost Suspension Heliostats	Solaflect
6349-001	Transparent, Flexible CdTe modules for High Efficiency Tandem PV	Lucintech, LLC
6354	Road to Grid Parity Through Development of Low-Cost 21.5% N-Type Si Solar Cells	Suniva, Inc.
6355	Rapid, Compact, c-Si Module Manufacturing	PPG Industries, Inc.
6356	Development of Manufacturing Technology to Accelerate Cost Reduction of Low-Concentration Photovoltaic Modules	Solaria Corporation
6358	Highly Automated Module Production Incorporating Advanced Light Management	Solarworld Industries America Inc.
6376	Automatic Design Optimization Software	Folsom Labs
6377	PACE3P® Financing Platform: Scalable Third-Party Ownership Commercial Financing	Demeter Power Group
6378	Utility-Scale PV Cost Reduction: Panelization for use with Automated Panel Installation System	Brittmore Group, LLC
6406	Macro-Micro PV Inverter Commercialization	Renewable Power Conversion
6407	Solar Data Everywhere	Geostellar
6408	Development of a Cloud-Based Interconnection Business Process Management (BPM) Software Solution	Clean Power Research
6413	Solar Socket	Infinite Invention, LLC
6414	Manufacturable High Efficiency (>20%) Interdigitated Back Contact Solar Cell Technology Using Si Heterojunctions	Applied Novel Devices, Inc.
6457	SMASH HIT	SMASHsolar

Table 10: Projects Reviewed under Technology to Market Program

Award Number	Project Name	Project Organization
6459	Single Silicon IC Photovoltaic Inverter	SineWatts
6461	One Step Super Emitters for High-Efficiency Solar Cells	Silicon Solar Solutions
6462	Aggregated Solar Asset Data for Efficient Financing	kWh Analytics
6463	Sun Number Commercialization Project	Sun Number
6464	Consumer Destination Site for PV Featuring a Reverse Auction Online Marketplace	EnergySage
6465	The Final Breakthrough in Solar Mapping	Solar Census, LLC
6466	Application to Streamline Solar Soft Cost Processes	Simply Civic
6468	End-to-End Workflow Automation for Solar Project Development	SunRun
6529	Genability's Verified Solar Savings	Genability
6530	Next-Generation Workflow Platform and Ecosystem for Solar Applications	SolarNexus, Inc.
6540	Interconnect Circuit Reliability and Scale-Up	Cellink Corporation
8238	Real-Time PV Manufacturing Diagnostic System	MicroXact, Inc.
8281	Apparatus for Optimizing Photovoltaic Solar Manufacturing Efficiency through Real-Time Process Feedback and Spectral Binning of Cells	Tau Sciences Corporation
9196	Utility-Scale PV Cost Reduction by Automated Panel Installation System	Brittmore Group, LLC
9232	Advanced Ceramic Materials and Packaging Technologies for Realizing Sensors for Concentrating Solar Power Systems	Sporian Microsystems, Inc.
9635	Reliability Improvement in Solution Processable Roll-to-Roll Photovoltaic Modules	Next Energy Technologies, Inc.
25814	Systems Analysis: Solar Manufacturing Cost Modeling and Analysis	National Renewable Energy Laboratory

## PROJECT: 4736 PPG INDUSTRIES INC.

### *Glass Innovations for Improved Efficiency Thin Film PV*

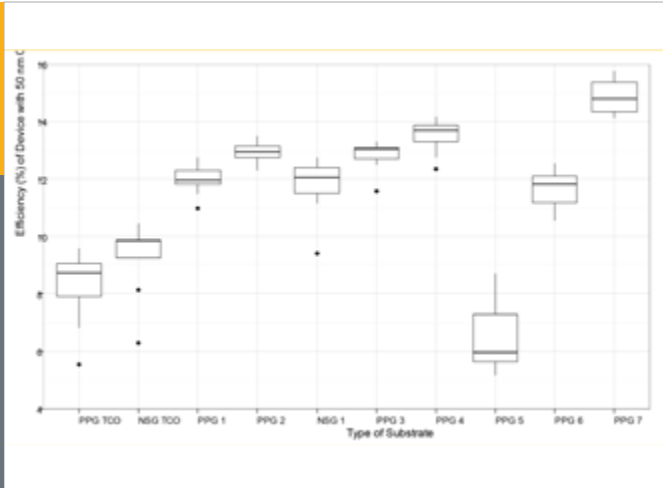

**FUNDING INFORMATION** \$2.8M | Supply Chain 2 | 04/2011–12/2014

## Project Description

The goal of this project is to develop the materials, coating designs, and manufacturing processes necessary to commercialize a new glass article for the cadmium telluride (CdTe) module manufacturing industry. This new glass article combines an improved transparent conductive oxide plus buffer layer, a high-transmission glass substrate, and a low-soiling antireflective coating (LSAC) into one product offering. The combination of these various technologies into a single product results in performance gains and improvements in module cost. The cost reductions stem from the choice of deposition technology, scaling to high-volume manufacturing, and systems integration of multiple coating operations.

## Individual Reviewer Comments

- The project has a fundamental approach to addressing a barrier in performance, well-segmented and phased for risk reduction. There are demonstrated equivalent sheet resistances.
- There is a good partnership between industrial and university research groups that is aligned on a common platform. The team showed good initial demonstration of the high-resistance transparent (HRT) potential; however, a lot of work needs to be done to validate with the end customer stack, as they have different layers and the Work-Functions needs to be adjusted accordingly. The project replaces a portion of the cadmium selenide in CdTe modules with a tin oxide (SnO<sub>2</sub>) HRT layer that can be applied on a float-glass line. This is a small but useful refinement for the manufacture of CdTe modules. More importantly, the project demonstrated slightly higher efficiency for cells made using the HRT, and a feasible explanation for the benefit is given in terms of

band-edge offsets. The project is nearing completion and has obtained relevant data from enough cells to be statistically significant. The results have been published in relevant conference literature.

- HRT work at the research level appears to mimic other commercial approaches and extend performance to new heights of discarding the intrinsic and F-doped SnO<sub>2</sub> in favor of improved morphology.
- The only information provided for this review was the poster. The key data presented is the quantum efficiency versus wavelength, which includes an unlabeled black curve of unknown significance. There is no indication of whether this coated glass has been successfully marketed to the photovoltaics industry (e.g., First Solar), which is surely the ultimate test of this project's impact.
- It is not clear from the narrative or poster the progress on LSAR layers cited in the objectives.
- There was no mention of commercialization pathways and complications that may be ahead (e.g., tradeoff between deposition speed and uniformity, cost estimation of proposed technology relative to incumbent, area scaling challenges).
- Device performance does not appear to meet or exceed state of the art for CdTe.
- The project shows a small improvement in efficiency. Jsc is not comparable to the Transparent Conducting Oxides work.
- There are many competing techniques to improve the LSAR coatings. The key is the cost and reliability of the LSAR coatings to survive the knife test.



## PROJECT: 4737 APPLIED MATERIALS, INC.

### *Reduced Cost and Manufacturing Complexity of High-Efficiency IBC Solar Cells Using Ion Implantation and In-Situ Patterning*

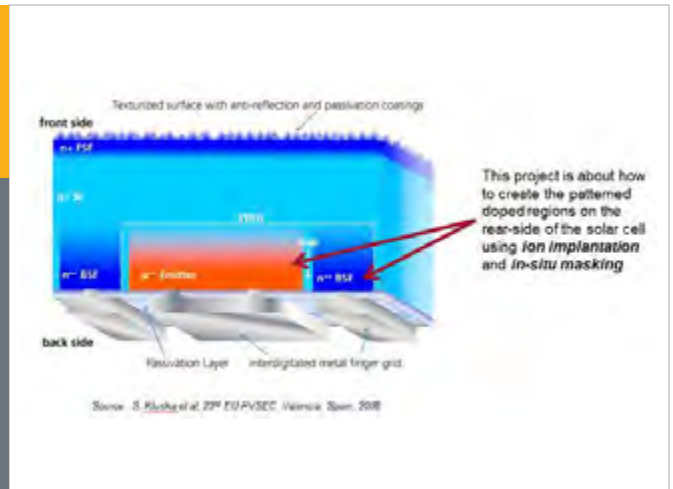

**FUNDING INFORMATION** \$4.8M | Supply Chain 2 | 04/2011–06/2014

### Project Description

The majority of present crystalline silicon (c-Si) photovoltaic (PV) cells are fabricated by diffusing an emitter junction into a doped wafer, with the emitter electrical contact formed by a metal grid screen printed on the front side of the cell. One established path toward increasing cell efficiency is to place both the emitter and base contacts on the back side of the PV cell, thereby increasing absorbed light by eliminating the front contact grid. Process steps to create this back contact structure are presently more expensive per wafer than the standard cell. A high throughput ion implantation tool that can pattern while implanting can reduce cost by creating emitter and base regions in a single process step while achieving higher efficiency. Applied Materials is developing a patterning capability for a solar ion implant tool that enables the creation of patterned doped regions on an interdigitated back contact (IBC) solar cell in a single process.

### Individual Reviewer Comments

- This project addresses a key barrier to IBC fabrication (number of unit operations) by combining steps and using detailed patterning capabilities of beam-line implanter. Credible results have already been published by this group on the topic, and incremental gains look to be under development.
- The commercialization and scale-up potential of this process/toolset is easily identifiable and likely with a successful outcome from these work packages.
- This project proposes to reduce the cost of IBC cells by using in-situ patterned ion implantation to form the n+ and p+ regions on the back surface (and also an unpatterned FSF). An excellent cell efficiency of greater than 22% on a full-size cell has been obtained in conjunction with reputable European partners.
- The silver-free, plating-free process sequence presented for this project is consistent with a module manufacturing cost in dollars per watt similar to mainstream mc-Si Al-BSF technology (when implemented at comparable scale), but with much higher efficiency, resulting in an approximate 15% reduction in the levelized cost of energy. If, in the future, the cost of n-type wafers fails to reach parity with p-type wafers, then the proposed approach could even become less expensive than standard technology on a dollar per watt basis. The successful sale of these tools to two customers is a major sign of success.
- This process requires the alignment of four patterns: P implant, B implant, via etch, and metal etch. Although one graphic shows reasonable control over the implant pattern consistency, there are no data regarding alignment between different implant patterns. Adequate alignment of the subsequent screen-print steps is probably achievable at acceptable cost for a company such as Applied Materials, which has extensive experience with screen printing, but only with some organized effort.

- There is some concern that 22.1% cell efficiency does not meet or exceed incumbent technology, nor is it excessively above that of competing technologies (HJT, PERT, etc.) that have a lower consumable and/or capital cost structure.
- There is an obvious absence of U.S.-based cell fabrication partners—both research and commercialization scales are outside the United States—despite Suniva’s and SunPower’s potential use of this technology. This project would pair well with thin wafer technologies being developed in other U.S. Department of Energy projects or programs.
- There is no mention of throughput per tool cited to ascertain whether performance will come at a capital expenditure cost penalty.

## PROJECT: 4739 3M COMPANY

### *Ultra-Barrier Top-Sheet for Flexible PV*



**FUNDING INFORMATION** \$4.3M | Supply Chain 2 | 04/2011–06/2014

### Project Description

3M's objective is to develop and commercialize a flexible, highly transparent ultra-barrier top-sheet (UBT) that enables successful commercialization and growth of flexible solar modules manufactured from second- and third-generation photovoltaic (PV) technologies. This UBT is being manufactured with a proprietary high-volume, low-cost roll-to-roll process that has the potential to meet or exceed the technical requirements for these solar technologies. Successful commercialization of the UBT could have a dramatic impact on the solar industry by reducing total costs for installation in current markets, such as commercial rooftop and residential building-integrated PVs.

### Individual Reviewer Comments

- The investigators have the best team for the project (3M and the National Renewable Energy Laboratory). There has been good water vapor transmission rate test results data.
- A good prototype (Gen I UBT) was in hand at the project start. The project has an improved Gen II UBT in the development pipeline. The testing methodology is both early and rigorous, going beyond standard tests to understand and engineer solutions for key reliability issues at the pilot stage of development.
- This work will finally deliver to the industry a flexible front sheet, which has been something the industry has wanted for 30 years. It is an impressive approach to the development and reliability and is a testament to the fact that companies like 3M bring a lot of knowledge and horsepower to solving a difficult problem.
- The project aims to develop a flexible top-sheet for PV module applications, specifically for thin film technology platforms where moisture ingress has proved to be an issue for long-term reliability. If successful, the new top-sheet would replace glass with a transparent, lightweight, flexible, UV-stable film that is impervious to moisture ingress. Such a product would offer a good solution for thin film module technologies, where low water vapor transmission rate is needed for reliability, flexibility is beneficial for roll-roll manufacturing methodologies, and lightweight is a desirable module attribute for installed systems. Therefore, the project is relevant to the PV supply chain program goals.
- The project objectives focus on (1) scaling a first-generation product from pilot to manufacturing scale and validating its reliability on a 25-year time scale and (2) developing a second-generation top-sheet with improved product metrics and then transferring that product to manufacturing. These efforts will further two products in the development pipeline, with the first-generation product poised for market entry, where it can have an impact on the PV supply chain by providing a top-sheet solution to thin film module manufacturers, and the second-generation product in the wings to improve upon that solution. If successful, the project/product will be impactful to the program goals.
- The project has a platform technology in hand (Gen I UBT). The general approach seeks to scale production (volume and roll width) in combination with rigorous product testing, including reliability testing. Of note, product testing goes beyond standard certification tests to validate performance on several metrics and against

reliability risks. This is an excellent and best practice approach, and it seems that the project team has a high likelihood of bringing a product to the marketplace.

- The project is funded at close to \$9 million over 3 years with a 50% cost share. This amount is adequate and appropriate for the objectives and goals of the project.
- The FlexPV market (especially organic PV/dye sensitized solar cells) has not taken off and could impact the commercial success of the product.
- Encapsulant is much more expensive compared to glass.
- The project team needs to measure transmission versus glass.
- It is not clear which PV module technology platforms and market applications will be suitable for the product. Most require some high-temperature processing, which may limit the product to grown-on-substrate (as opposed to grown-on-superstrate) technology platforms. It would be appropriate to engage with module manufacturers at this stage of pilot production, for PV-related tests, product integration tests, and business development.

## PROJECT: 4946 STANFORD AND UNIVERSITY OF CALIFORNIA, BERKELEY

*Bay Area Photovoltaic Consortium*

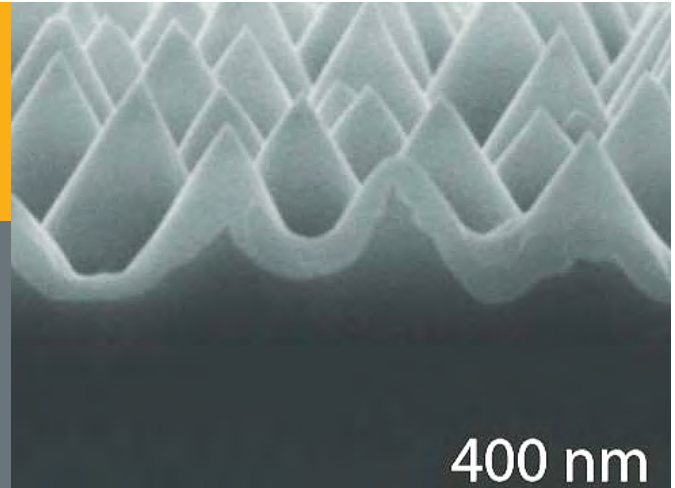

**FUNDING INFORMATION** \$25.0M | Supply Chain 2 | 08/2011–06/2016

### Project Description

Expertise and research and development (R&D) tools available at universities can be critical for solving many of the difficult technical challenges of photovoltaic (PV) technology. However, it can be difficult for university researchers to directly connect their work to real-world issues. Problems that need solutions are not well-articulated, and opportunities that require solutions are missed. The Bay Area PV Consortium (BAPVC) forms direct connections between industry and universities by soliciting requests for proposals; its project review process; and its biannual meetings, which link companies and leading university researchers. The BAPVC funds industry-relevant R&D to impact high-volume PV manufacturing using a competitive selection process open to all universities. This project, managed by Stanford University and the University of California, Berkeley, develops and tests innovative new materials, device structures, and fabrication processes necessary to produce cost-effective PV modules in high volumes. The research advances technologies that bring down manufacturing costs and improve device performance characteristics to help achieve SunShot cost targets. Member companies determine the specific topics for R&D to ensure close alignment with industry and manufacturing needs and review individual project progress.

### Individual Reviewer Comments

- This is the most comprehensive approach to getting the performance of solar cells improved. It involves the best universities in the country working on and sharing data in areas that will guide the next generation of solar cells. Strengths include a solid project portfolio, strong project teams, strong leadership, strong governance, and

evidence of strong collaboration between institutes and principle investigators.

- The team has conducted front-end research with disruptive concepts being inserted into project plans. The center has established a productive and collaborative entity, with thrusts leading in important directions, each with a strong set of projects.
- There is a comprehensive list of participants, spanning several sectors of PV.
- The project captures all required cost elements to make solar sustainable (except possibly balance of systems).
- The project follows a managed portfolio approach, with a broad spectrum of smaller projects with smaller project teams organized into five thrust areas. The leadership team manages the portfolio with a Request for Proposal/granting process that is (presumably) informed by the overall aim of the project. A key feature is biannual meetings of participants, which facilitates strong interaction among subproject teams. The project portfolio looks very strong.
- The aim of the project is to provide a forum for interaction among PV industry and academics to address challenges to bringing U.S. leadership in PV R&D to leadership in PV manufacturing. Therefore, the project is relevant to the Photovoltaic Manufacturing Initiative.
- Although the focus is broad, if the project can bring synergy and collaboration across thrust, then it is likely that the project can bring impactful outcomes to the program goals.

- The project is funded at \$31 million over 5 years with a 20% cost share. The cost share is relatively low compared to peer projects. Nonetheless, the level of funding is adequate and appropriate for the goals of the project.
- If successful, the center should be planning for sustainability beyond the 2016 horizon. The team should develop an aggressive strategy to boost external funding. While the project strategy for managing/facilitating early stage R&D/prototyping pipeline is strong (e.g., 'Exploratory Photovoltaic Modeling and Simulation'), there is no evidence of a project strategy to impact the later stage pilot/commercialization that leads into 'leadership in manufacturing.'
- There is little to no accountability to deliver on milestones or meaningful output (other than intellectual property). Concepts are struggling at identifying a commercialization pathway in many cases.
- Researchers selected for projects are not always those at the top of the field. It appears to be institutionally or network aligned instead.
- It seems like a heavy administrative/overhead burden, and it might be sensible to fund programs directly from the U.S. Department of Energy instead of using an intermediary organization.

## PROJECT: 4947 PVMC, INC.

### *U.S. Photovoltaic Manufacturing Consortium*

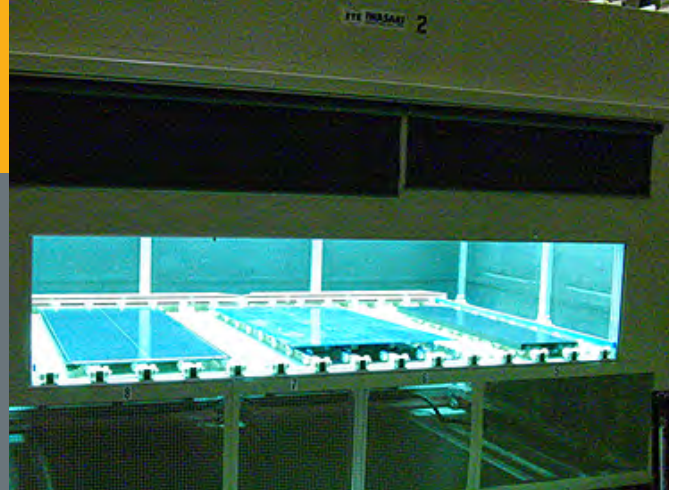

**FUNDING INFORMATION** \$62.5M | Photovoltaics Manufacturing Initiative | 09/2011–12/2017

### Project Description

The U.S. Photovoltaic Manufacturing Consortium (PVMC) is coordinating an industry-driven initiative to accelerate the development, manufacturing, and commercialization of next-generation, copper indium gallium diselenide (CIGS) thin film, PV manufacturing technologies, tools, and materials. PVMC seeks to drive down the cost and risk of bringing CIGS technologies to the marketplace. In partnership with the PV industry, PVMC has developed a PV Technology Roadmap as a guide for assessing research and development needs and opportunities for innovation. In addition, PVMC will operate complementary programs to foster new PV technologies and firms and develop the U.S. PV workforce. PVMC is also working with the University of Central Florida to develop cost-effective, in-line measurement and inspection tools to enable increased crystalline silicon PV manufacturing yield.

### Individual Reviewer Comments

- Collaborations are evident in metrology-related dimensions of the organization's objectives by assembling tool vendors, institutes, and specification agencies under one umbrella to vet new approaches. The project has shown an excellent simulation and modeling of thin film PV optical losses and mitigation pathways possible for processors.
- The team is incredibly strong, and support from the state is strong. The thin film PV industry needs this support and will use it as they understand better what the capabilities are. The project is funded at a level of \$62 million over 5 years, which is more than adequate to achieve the program goals.
- The program aims to serve as a test bed for technology development and transfer; to study reliability issues; and to link labs, universities, and industry to enhance technology commercialization. The project aim is relevant to the Photovoltaic Manufacturing Initiative goals. Conflicts appear evident between objectives of this and other U.S. Department of Energy- (DOE) funded programs. If able to resolve, it will help this group's mission greatly.
- There is a high level of apparent industry and laboratory engagement, although it is not apparent which, if any, of the consortium members are active collaborators on which of the 11 projects; a 100-kilowatts peak CIGS pilot facility, advances in cadmium-free buffer layers (based on ZnOS), metrology for diamond wire x-section, and wire wear.
- Overall, it is difficult to get a sense of where the project will have significant impact above and beyond that likely from individual projects. Some projects could lead to significant impact; for example, the diamond wire work in silicon. On the other hand, many of Project 3's sub-objectives seem to lag state of the art and do not offer up any specific or new and exciting materials or methods. Therefore, it is difficult to determine from the abstract and poster how this program will be impactful.
- A key concern is the disparate nature of the project and focus areas. The program supports a wide spectrum of activities, spanning two material systems and covering process/tool development, metrology, and reliability. It is hard to see where the overall project will develop a strong core of expertise, a strong vision or focus, and a clever strategy beyond a collection of individual projects.

- The approach seems to lack a coherent theme, focus, or strategy at the consortium level. Many of the stated objectives are not supported by a rational approach to success; for example, there is no clear and rational approach to ‘establishing an effective PV commercialization support structure’ beyond ‘linking’ institutes, of which there is little evidence presented in the abstract/poster.
- The sum of the parts seems to fall short of the whole. It is hard to sense the larger impactful outcomes of the consortium beyond that of the individual projects. There doesn’t seem to be a clear justification for the silicon program based on the abstract/poster. The progress and outcomes to date described in the abstract seem small in proportion to the budget. Progress to date seems to fall short of what would be possible with the budget and given that the program is half way in; for

example, under metrology/findings and outcomes, a report has been compiled and an optical modeling has been performed. It is hard to see how this rate of progress will lead to significant impactful outcome—at the level commensurate with a \$62 million block grant—by the end of the program.

- Interconnectivity of project portfolio is absent; it appears as if it is a smattering of topics instead of the cultivation of a capability/resource center.
- It is unclear why many of the projects cannot be funded directly from the DOE in lieu of using PVMC as an intermediary, where administrative burden is high and value uncertain. Many of the stated objectives do not have a corresponding project (or at least no data were provided) to illustrate progress toward goals. The team should consider streamlining the portfolio to increase near-term impact.



## PROJECT: 4948 COLLEGE OF NANOSCALE SCIENCE AND ENGINEERING, STATE UNIVERSITY OF NEW YORK

*Solar Rochester*



**FUNDING INFORMATION** \$26.0M | Photovoltaics Manufacturing Initiative | 07/2011–09/2016

### Project Description

The College of NanoScale Science and Engineering is creating a fee-for-service, photovoltaic (PV) Manufacturing Development Facility (MDF) accessible to PV companies. The facility will be able to accommodate a range of services and equipment, including access to advanced tools, manufacturing expertise, secure fabrication space for users' proprietary tools, and pilot production services—all in a secure intellectual property environment. The MDF is focusing on the commercialization of silicon PV manufacturing processes and technologies. It aims to reduce the costs and development time for participating PV industry leaders to deliver innovative, emerging technologies from the laboratory to commercial manufacturing lines. These capabilities enable start-ups, materials suppliers, and other PV innovators to eliminate a major portion of their upfront capital costs and initial operating costs during product development and pilot production.

### Individual Reviewer Comments

- The project correctly addresses the need for a U.S.-based development center for crystalline silicon (c-Si) PV that universities, institutes, and companies can access. Progress toward the facility build-out and toolset transfer appears to be nearing completion.
- A test bed for development can be beneficial for small companies, university groups, and laboratories that do not have easy access to manufacturing facilities; some interesting technical focus areas have been identified.
- The basic approach to having a process development lab for the industry is a good one. The project aims to construct a state-of-the-art facility, on the scale of a pilot line, where c-Si PV technologies (spanning industry and university clientele) can be tested and developed, with care taken in regard to intellectual property. The project aims to support growth and maturation of a domestic PV manufacturing base by facilitating access to tools

needed to develop intellectual property into commercial technology/products. If successful, the program can enhance PV manufacturing capability by facilitating commercialization; therefore, it is relevant to the Photovoltaic Manufacturing Initiative goals.

- A multiuser facility can speed development, as has been demonstrated very successfully by the Fraunhofer Institute for Solar Energy Systems institute (Germany). If similarly successful, this project can have an impact on the program goals.
- The project is funded at a level of \$34 million over 5 years with an approximate 66% cost share. The funding is more than adequate to achieve the aim and objectives of the project.
- The approach to constructing the facility is straightforward. The abstract/poster fail to present a path to achieving objectives 2–4; however, noting that more than half a page of the allotted abstract limit was not utilized. Therefore, the project's approach to protecting intellectual property, attracting and engaging companies, and advancing PV manufacturing innovation, education, and workforce development cannot be assessed.
- The project appears to be significantly behind schedule to reach the project goals by 2016. There is no evidence of interested clientele or a plan to attract users and no plan for education and workforce improvement. There is also a lack of a strong strategic plan/roadmap for technology development.
- No strong case for sustained operation beyond the duration of the funding was presented. It is unclear if the capabilities being installed will be able to competitively match those of organizations in high volume.
- Impactful deliverables will be technical/collaborative in nature, whereas this narrative/poster is a little sparse with respect to meaningful content.

## PROJECT: 5737 1366 TECHNOLOGIES

### *Project Silicon: Reclaiming U.S. Silicon PV Leadership*



**FUNDING INFORMATION** \$7.0M | Scaling Up Nascent Photovoltaics AT Home | 09/2012–09/2014

## Project Description

This award is assisting the industrial-scale demonstration of 1366's Direct Wafer process—an innovative, kerfless approach to forming multi-crystalline silicon wafers. Traditional silicon wafers are sawn from large silicon ingots, producing thousands of wafers per ingot. Sawing turns half of the ingot into sawdust, known as kerf-loss. Direct Wafers are made directly from molten silicon, circumventing the sawing process, which may reduce manufacturing costs by 50% compared to traditional processing.

Furthermore, Direct Wafers have the same form factor as traditional wafers, allowing “drop-in” compatibility with existing cell production lines. Approximately half of the current global photovoltaic (PV) shipments use multi-crystalline wafers, of which, the wafers themselves are a multibillion-dollar market. This project supports the design, build, and demonstration of 1366's industrial-scale Direct Wafer producing equipment; the layout, design, and construction of a pilot-scale manufacturing facility; and commercial development activities.

## Individual Reviewer Comments

- The applicants have already successfully demonstrated significant manufacturing cost efficiencies with their innovative manufacturing process. It is assumed that scaling-up production would yield further economies.
- The project correctly addresses a key cost barrier for material utilization of crystalline silicon PV; however, this constraint has recently been relaxing with the cost of silicon feedstock dropping.
- The project involves U.S.-based research that is helping to scale a U.S.-based manufacturing facility, which will

significantly shortcut the cycles of learning. In addition, the customer network and market survey are well-constructed for ensuring commercialization pathway upon the project's success.

- A strength of the project is the lower module, lower wafer read out integrated circuit (ROIC) (15.25% module champion efficiency).
- The project aims to commercialize the Direct Wafer technology with corresponding savings in silicon cost. The approach can save approximately 50% of the silicon materials, with similar savings in silicon wafers. Silicon is one of the main components of module cost. Additionally, the approach has potential to reduce capital expense, improving depreciation cost and ROIC of wafering. Therefore, the project is relevant to the SUNPATH program goals.
- The project is funded at \$28 million with a 75% cost share. The funding level is more than adequate for the aims of the project.
- The abstract and poster present generic information indicative of the approach. At a high level, fitting out a facility for production and acquiring process tools is a necessary approach. Little technical detail is presented beyond this general approach, so it is difficult to assess risk mitigation, deployment strategy, key technical issues under investigation, etc.
- The case for how the project can have an impact on the program goals is not well supported in detail (for example, one blank page of the abstract could have been used to make a strong case for impact).

- The program appears to be subsidizing the funding of the scale-up of a proprietary technology on behalf of a corporation's interests, in lieu of a pilot demonstration that can be openly accessed by domestic industry to achieve competitive costs in a global market. Please clarify.
- It is not clear that lower costs will not be offset by lower efficiency (and hence lower overall system cost metrics). Little technical data are given in the poster/abstract to assess the technical progress/status of the project. The large quantity of generic industry data presented in the poster does little to showcase the project aims, objectives, and results to date. It is not clear how the Direct Wafer process will lead to lower manufacturing variability, as suggested in the poster.
- Capital expenditure displacement justifications for the project are not substantiated in the narrative or poster with data that cite progress toward goals on either a grams per watt-peak or U.S. Dollar per watt-peak basis. Levelized cost of energy basis can be derived from sources outside these deliverables.
- It is unclear about the fit-for-purpose qualification metrics of resulting substrates. While performance of Direct Wafers is shown in the poster to approach that of conventional multi-crystalline silicon, neither the baseline nor the proposed technology meet or exceed the state of the art for the incumbent technologies, making the relative comparison accurate, but the absolute benchmark uncertain.
- More detail on the nature of the innovative machine that eliminates several competing machines would be appreciated.
- The applicant has demonstrated significant cost reductions in the manufacture of high-intensity, high-efficiency cells for concentrated photovoltaic (CPV) plants. However, to date, CPV has struggled to get the total systems cost into a competitive range. While reducing the cost of the cell is wonderful, the proposal would have been stronger had the applicant shown that the total system cost led to a cost competitive or below the cost of simple flat-plate PV installations. At this point, the demand for CPV installations has not been great.

## PROJECT: 5738 SOLAR JUNCTION

### *Large-Scale Commercialization of Dilute Nitride Triple Junction Solar Cells*

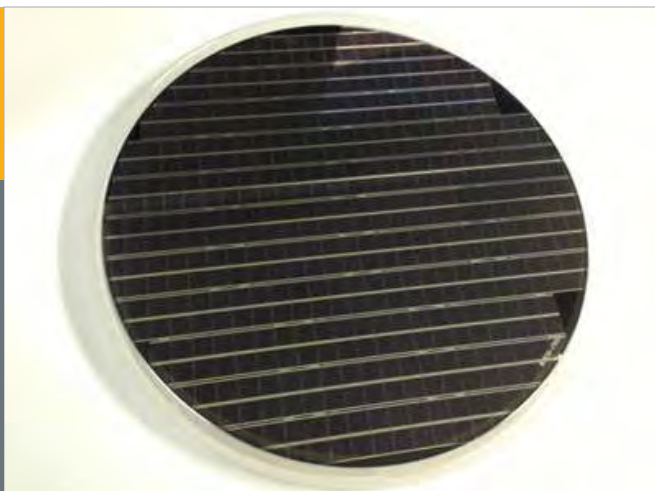

**FUNDING INFORMATION** \$4.8M | Scaling Up Nascent Photovoltaics AT Home | 09/2012–04/2014

### Project Description

Solar Junction is expanding its manufacturing capacity and reducing the costs of its high-efficiency (greater than 40%) triple junction solar cells. Solar Junction's cells are suited for high-concentration photovoltaic (HCPV) applications, where sunlight is tightly focused onto a small-area cell. Driving down the cost of manufacturing and increasing cell efficiency is important for making HCPV technology cost competitive. Under this award, Solar Junction will progress toward SunShot's cost targets by a three-pronged approach. First, Solar Junction will make technology improvements to increase cell efficiency, which increases the power output per cell area. Second, cell processing will migrate to a larger substrate size, which increases manufacturing capacity and reduces scrap. Third, an asset-light strategy for wafer fabrication will be employed, where Solar Junction outsources its high-volume wafer growth to IQE, an epitaxy toll manufacturer. By award end, Solar Junction aims for an annual capacity of 40 megawatts with more efficient cells that cost 20% less.

### Individual Reviewer Comments

- Strengths of this project include high efficiency demonstrated and a low lattice mismatch technology platform. The project has demonstrated excellent cell efficiencies for high-concentration systems, as cited values meet or exceed state of the art for this and incumbent technologies.
- According to statements made in the narrative and on the poster, it appears that Phase I deliverables with respect to facility and performance are met.
- 40 megawatt-peak capacity of facility will be a significant contribution to industry. The applicant has already demonstrated the fundamental technology, and the proposed cells have very high thermodynamic efficiency.
- The project aims to develop 150 millimeter fabrication capability for triple junction, high-concentration solar cells based on GaInNAs, gallium arsenide, indium gallium phosphide materials. The material system has the advantage of high efficiencies in a triple junction structure while avoiding high strain and defects generated by growth on germanium, leading to a more robust and higher-efficiency cell in manufacturing.
- Scaling production capability and capacity is important to achieving a competitive commercial product; therefore, the project is relevant to the SUNPATH program goals.
- This approach is appropriate for the aim of the project. If successful, the project will establish this leading-edge cell and material system in manufacturing in the United States, and therefore will have an impact on the program goals. The project is funded at \$4.8 million with a 75% cost share. The level of funding is adequate and appropriate for the scope and goals of the project.
- Outsourcing epi will require attention to quality control. It is not clear that the new technology advances system performance/cost to ensure success in the marketplace where other concentrated photovoltaic system approaches have failed. Larger wafers have some cost advantages in manufacturing, but many cost of goods manufactured (COGM) scale with area, including wafer costs, so it is not clear from the abstract/poster that

this effort will bring a significant COGM savings. It is not clear from the abstract/poster that the downstream business is well developed (receiver package, optics, mounting, tracking, etc.).

- Little to no data were offered to support assertions aside from photos of the facility and a cell-efficiency spatial map, which makes it difficult to review development progress. In addition, there was no cost information relayed that would support conclusions that a 150 millimeter process is on track to meet SunShot targets.

Information was missing from the narrative and poster on how the bill of materials is reduced. There was not enough discussion of cell cooling and its costs.

- The application would have been stronger if it had contained more cost projections comparing the projected cost of simple flat-plate PV with this innovation. It would have also been stronger with a description of the full system architecture.

## PROJECT: 5739 SOITEC SOLAR INDUSTRIES

SANFAB



**FUNDING INFORMATION** \$25.0M | Scaling Up Nascent Photovoltaics AT Home | 09/2012–04/2014

### Project Description

Soitec is an international industrial manufacturing company that develops and manufactures semiconductor materials and concentrating photovoltaic (CPV) power plant technology. SUNPATH is assisting with building a highly automated 280-megawatt-peak (MWp) factory in San Diego (also known as SANFAB) for the production of its CPV modules, which have efficiencies of approximately 30%, compared to the 15%–20% efficiency of non-concentrating flat-plate PV modules.

### Individual Reviewer Comments

- Co-location of a U.S.-based research and manufacturing footprint will shortcut cycles of learning significantly. In addition, the project having significant investment from partners illustrates commitment to the technology. Progress toward factory build-out has also been demonstrated, and the thermodynamic efficiency of the CPV approach is much higher than simple flat-plate PV technologies.
- Project strengths include high automation, lean approach, quality systems approach, deployed products, project pipeline filled, and milestones completed. The technology is well-understood and proven.
- The project is funded at around \$110 million with a \$91 million cost share. The funding level is very strong for the proposed project and will help ensure a successful launch of the manufacturing facility and the CPV module product.
- The project objective is to deploy a 280-MWp factory to supply PV systems in high direct normal irradiation regions, creating domestic jobs and spurring the CPV

industry. In these regards, the project will prove to be impactful to the program goals.

- The aim of the project is to deploy a 280-MWp solar module factory in the United States to make Fresnel lens, high-magnification CPV modules with efficiencies approaching 30%. A high degree of automation, manufacturing tools based on existing industry (printed circuit board and automotive), and a lean/quality focus will allow low-cost manufacturing. Therefore, the project goals are relevant to the SUNPATH program goals.
- The approach is straightforward to fit out and operate the factory. Application of manufacturing principles for high-volume products should prove beneficial in reducing cost of goods manufactured (COGM). Results to date demonstrate that the factory fit out and ramp has been very well executed. Therefore, the approach is appropriate for the goals of the project.
- A robust, continuous-improvement and cost-reduction plan/roadmap would strengthen the likelihood of a sustainable and profitable future. Ongoing reliability monitoring would also prove beneficial.
- Absent data from the narrative and poster make it difficult to review the progress toward the deliverables. Cost compression progression and performance milestones are unclear.
- Substantial funding outlay by both the U.S. Department of Energy (DOE) and project team seems heavy for 280-MWp capacity compared with GTM figures of less than 20 million U.S. Dollar/100 MWp for conventional crystalline silicon plants.

- There are concerns over program goals of ramping proprietary technology for an individual corporation's interests in lieu of demonstrating merit of technology. Please clarify.
- The lesson learned from the Solyndra experience was that cost efficiency trumps thermodynamic efficiency any day. Although the Solyndra thermodynamic efficiency was similarly very high, in the end, they could not compete with the lesser thermodynamic efficient, but lower-cost flat-plate PV products.
- This proposal would have been much stronger if it had included cost projections showing that Soitec will not experience a similar fate. The authors have not addressed whether their high-volume production will lead to levelized costs of energy that support the SunShot goals. Further, developers of simple PV products forecast additional future cost reductions beyond today's prices. Soitec must show that its projected future costs are not only lower than today's flat-plate PV prices, but also competitive with tomorrow's prices as well.
- The author seems to rely on the sunk costs of the DOE's prior investments as justification for continued funding. However, absent cost projections, the viability of this investment cannot be judged.

## PROJECT: 5835 MOSAIC

### *Crowd-Funded Solar Projects*



**FUNDING INFORMATION** \$2.0M | Incubator 6 | 06/2012–09/2014

### **Project Description**

Solar Mosaic is bringing much-needed capital to the solar industry by building a Web platform for everyday Americans to create and fund solar projects. Mosaic's unique online crowd-funding platform will help reduce the soft costs of solar financing and customer acquisition while enabling thousands of Americans to own a piece of the growing clean energy economy.

### **Individual Reviewer Comments**

- The project offers accessible loans to the mass market. This is a viable and strong crowd-funded solution to affordable loans in a market where the lack of trust by banks could/would slow the cycle of solar adoption.
- The ability to prove the asset class (solar installations) over time is of value and is a direct tie to SunShot goals, though it may be difficult to calculate the full impact. The secondary market of lead generation and the monetization of that added benefit is a positive outcome.
- Pursuit of different marketing strategies is of benefit, as well as partnering with other organizations to get the word out that these loans exist for customers.
- This seems like an expensive endeavor to create a crowd-funding database and program. It seems that the program has had difficulties, but they are not described well enough to tell what is going on. It is indeed novel and will break the traditional means of capital-raising. However, there could be public dissatisfaction if this is not scaled with the investor base communications as its highest priority. The project should be rated at 5 for novelty and risk.
- The cost of point on the loan seems high. U.S. Securities and Exchange Commission crowd-funding laws are a moving target. Stability and predictability for compliance may be changed regularly until the market settles down. Much of the personal capital in vision seems tied to one person.
- Valuation of soft-cost impact is hard to calculate.



## PROJECT: 5977 STION

### *Scale-Up and Optimization of CIGS Tandem Module for Production Readiness*



**FUNDING INFORMATION** \$2.0M | Incubator 7 | 12/2012–06/2014

### Project Description

Stion has developed a disruptive technology based on a tandem copper indium gallium diselenide (CIGS) module that uses a revolutionary thin film design to enable broader and more effective harvesting of available light. The tandem module, which utilizes mechanically stacked top and bottom modules to avoid the design and manufacturing challenges associated with multi-junction monolithic integration, enables 18% efficiency on full-size CIGS modules.

### Individual Reviewer Comments

- The authors propose an innovative dual surface approach to achieve higher thermodynamic efficiency. The authors were specific in providing an approach, and importantly cost projections.
- The proposal is said to reduce the levelized cost of energy of the proposed product to rates below the SunShot goal and describes how the grant funding would be utilized.
- A mechanically stacked tandem is a promising approach in that it decouples many of the materials' compatibility issues, though it presents a cost challenge if it is necessary to use three glass sheets instead of two. The progress to date is creditable, especially in view of the modest funding provided by the incubator funding program.
- Despite the good progress, the awardee seems to find it necessary to exaggerate its progress by reporting that it has demonstrated an 18.8% full-size module, without clarifying that this is a four-terminal aperture-area measurement. In practice, four-terminal operation would impose unacceptable balance-of-system costs, so the meaningful result is the 16% National Renewable

**PROJECT: 5982**  
**REHNU**

*Production-Ready Dish-CPV  
Generator*



**FUNDING INFORMATION** \$1.0M | Incubator 7 | 10/2012–05/2014

## Project Description

REhnu is transitioning a new concentrating photovoltaic (CPV) technology, already proven in a University of Arizona prototype, to a low-cost form ready for commercial production. The technology uses large glass dish reflectors, each with a compact array of CPV cells at its focus. This makes it economical to build systems with an extended 40-year lifetime and maintain high power output by swapping in new cells as multi-junction technology improves.

## Individual Reviewer Comments

- The authors propose a unique and innovative optical arrangement. In addition, the facilities and staff available to support this development are very respectable.
- The proposal would have been stronger had it included cost projections suggesting that a levelized cost of energy below the SunShot goals was achievable. This is especially so given the design of self-supported (thick) primary mirrors and the structural steel framework and drives required to complete the structure. Development of different CPV systems has been followed for the last several years. The excitement over the high thermodynamic efficiency of such cells has been tempered by the low cost efficiency of proposed designs.
- The design and the costs of the active cooling system need to be better understood.

## PROJECT: 6037 SOLAFLECT

### *Deploying Low-Cost Suspension Heliostats*



**FUNDING INFORMATION** \$1.0M | Incubator 7 | 02/2013–04/2015

### Project Description

Solaflect Energy has developed a low-cost Suspension Heliostat™ that dramatically reduces steel usage by utilizing steel cables instead of steel truss structures to stabilize mirror panels. The SunShot project will focus on continued development of the heliostat design, design for robotic manufacture, reduction of manufacturing and installation labor requirements, and transition to high-volume commercialization.

- Although the weight of support structure has been dramatically reduced, the parts count and assembly complexity have both been increased.
- It would be useful to understand how canting adjustments are made in the field. The proposal would have also benefited from a brief breakout of the costs to achieve the goal of a heliostat at a cost of \$75/square meter.

### Individual Reviewer Comments

- The author's innovation succeeds in dramatically reducing the material intensity of the structural support framework from the base Sandia legacy design. The author's progress toward high-volume, low labor cost assembly is a major benefit, and the compact shipping format should reduce shipping costs and enable rapid job site deployment.
- The highest cost per square meter in heliostats is not the support structure, but in the drives. A second high-cost component is the foundation. This innovation does nothing for these higher-cost components. In addition, the proposal has not described how heliostat washing is to be accomplished given the web of guy wires crossing in front of the mirror.

## PROJECT: 6349-001 LUCINTECH, LLC

### *Transparent, Flexible CdTe Modules for High Efficiency Tandem PV*

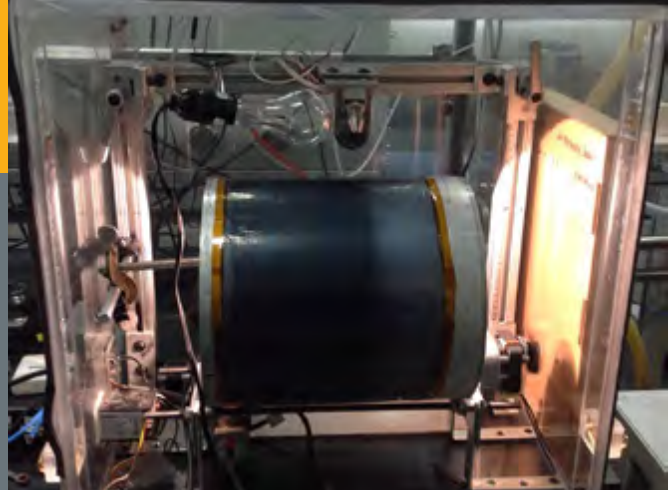

**FUNDING INFORMATION** \$1.0M | Small Business Technology Transfer 2 | 08/2012–08/2014

## Project Description

Polycrystalline thin film cadmium telluride (CdTe) is a candidate material for a top cell in multi-junction thin film solar cell structures, but its use is limited by the lack of high-performance transparent back contacts to the CdTe. In this project, Lucintech, LLC and its research partner—the University of Toledo—are adapting single-wall carbon nanotube structures for CdTe solar cell electrodes and scaling-up toward the manufacturing of magnetron-sputtered cadmium sulfide/CdTe devices with very thin and smooth CdTe layers ideal for applying transparent back contacts. The goal is to develop a top-cell structure for flexible tandem modules to match a low-bandgap bottom cell, such as copper indium gallium diselenide or silicon, and to optimize a stand-alone, transparent top cell with less than 500 nm of CdTe for use in photovoltaic (PV) window applications.

## Individual Reviewer Comments

- The team has demonstrated significant progress toward objectives and deliverables through fundamental and proof-of-concept sample data. The project team also has a sound grasp of state-of-the-art and market penetration criteria and key barriers being addressed in research programs. The team also has capable partners. Commercialization pathways are identified, and implementation is likely upon successful project outcome.
- Mechanically stacked tandem thin film modules of CdTe and CIGS is a promising approach for PV power production. This project takes a step in that direction by developing the applicable unit processes. The company aims to produce initial products for high-value building-integrated photovoltaic and automotive markets, which is important to attain financial sustainability for the longer-term goal of tandem power modules.
- The team has demonstrated its ability to produce excellent CdTe minimodules using a variety of process variations appropriate for these applications.
- The best combination thus far of transparency with efficiency is 60% transparency at 13% efficiency. This is promising, but does not provide high confidence that a marketable tandem product is likely to result from this project. However, additional funding may be able to leverage additional results and development gains.
- There is a diverse array of technology enhancements being attempted simultaneously. If a resourcing conflict arises, some prioritization would be beneficial. It is unclear from narrative and poster whether this exists.
- The benefit of the single-wall carbon nanotubes contacts, w.r.t. convention contacts, is unclear.

## PROJECT: 6354 SUNIVA, INC.

### *Road to Grid Parity through Development of Low-Cost 21.5% N-Type Si Solar Cells*

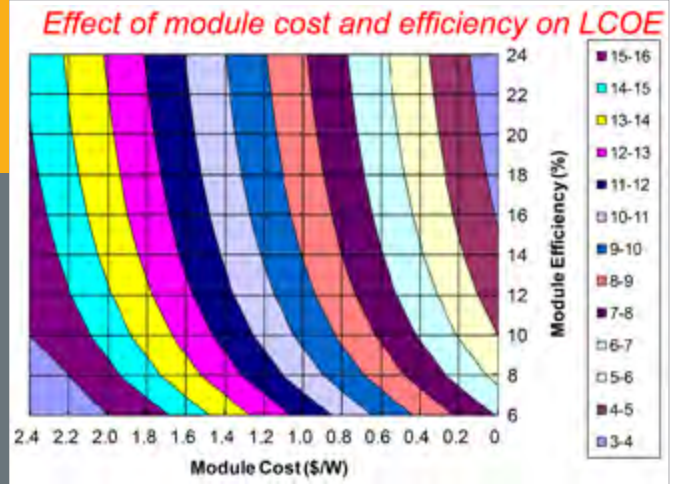

**FUNDING INFORMATION** \$4.5M | Solar Manufacturing Technology | 10/2014–09/2016

## Project Description

The majority of present crystalline silicon (c-Si) photovoltaic (PV) cells are fabricated on p-type c-Si substrates that have limited minority carrier lifetime and therefore limited efficiencies. Moving to n-type silicon allows for longer lifetimes and more efficient cells. However, the movement toward n-type substrate material has been slow as changes in process and equipment require significant development. This is an important step on the ever-moving PV roadmap. Suniva, Inc.—in partnership with the Georgia Institute of Technology—will develop a low-cost, highly efficient silicon PV cell technology that will reach the marketplace within 3 years and meet the SunShot 2020 target of less than or equal to \$0.50/watt module cost. This effort will overcome cost and efficiency barriers through advances in PV science and technology innovation involving new process tools and result in pilot production of 21.5% efficient cells.

## Individual Reviewer Comments

- This project has a straightforward, theory-based, and practically applied approach from Georgia Tech. This industrial approach to making solar cells will be successful and is highly relevant to a large part of the industry.
- A strength of the project is the n-type silicon wafers that have demonstrated capability for high efficiency (by other companies). There is also a good understanding of key parameters to tweak to hit 21.5% efficiency. The 21.5% n-type cells resulting in 50 c/Wp will help drive the SunShot goals.
- The project objectives address four key problems of the n-type cell technology platform: boron diffusion, boron diffusion passivation, metallization for boron diffusions, and process integration. The program also includes an objective to improve screen print lithography critical dimensions to reduce overall shading losses. An n-type cell platform has proved to be elusive, barring a few key players that have demonstrated very high efficiencies in n-type wafers, close to or exceeding 25% in champion cells, and close to 23% in volume production. Therefore, the project can be impactful to the program goals, if successful.
- The project aims to develop a silicon cell technology based on n-type wafers, with high-efficiency silicon, low process complexity, and a compatibility with thin wafers as the pathway to low module and system cost. If successful, the technology platform will be suitable for volume manufacturing. Therefore, the project aims are relevant to the SolarMat program goals.
- The budget for the project is \$9 million over 3 years. This funding level is appropriate and adequate for the scope and objectives of the project, considering its strong manufacturing focus.
- The project has identified, and is addressing, the key issues pertaining to realizing an n-type silicon cell technology platform. On the other hand, the abstract and poster are vague about the technical approach to the individual objectives; therefore, the adequacy of the project's approach cannot be assessed. The loss analysis with efficiency predictions of 21.5% contributes little to the definition of the technical approach (21.5% is not an aggressive enough target for n-type cells). Also,

the abstract claims to enable thin wafers; however, a technical pathway/leverage is not made clear (lower recombination and better light trapping are obvious; what is lacking is an identified technical pathway to both). Therefore, it is difficult to see how the proposed project will be compatible with thin wafers.

- The main driver of the cost is the high cost of the n-type wafers (the program does not address the same). In addition, the approach to thin wafers is poorly supported, offers little to a breakthrough in metallization (short of optimizing screen printing, which is fairly mature),

has no evidence of progress on 'alternate metallization,' shows no evidence of progress on passivation (648 mV is mediocre, n-type wafers are capable of more than 680 mV), and the 26 micrometer improvement in printed finger width is difficult to assess because no state-of-the-art benchmark is provided.

- The diffused junction approach is at risk of significant competition from heterojunction cell approaches (which offer 725 mV++ and greater than 25% champion efficiencies).

## PROJECT: 6355 PPG INDUSTRIES, INC.

### Rapid, Compact, C-Si Module Manufacturing



**FUNDING INFORMATION** \$2.1M | Solar Manufacturing Technology | 09/2013–09/2016

## Project Description

PPG Industries, Inc. will partner with Flextronics International, Inc. to design and pilot a rapid photovoltaic (PV) module assembly process that replaces labor-intensive packaging steps with automation. The process uses an all-liquid encapsulation approach to completely eliminate lamination. The team will optimize encapsulation and backsheet formulations and develop the application processes required to rapidly and consistently dispense them, along with an automated system to place a 60- or 72-cell matrix into the encapsulant.

## Individual Reviewer Comments

- The project appropriately pairs materials provided with an integrator in that commercialization pathway will be fully explored and vetted, hopefully leading to rapid implementation upon the project's success. In addition, U.S.-based partners appear to be engaged to install production footprint within the United States to shortcut the cycle of learning between research and manufacturing.
- The approach applies cost pressure to incumbent materials and technologies to relax burdensome pricing structure of consumables. Widespread adoption of this approach would provide a significant market for the U.S. companies who provide the encapsulation equipment and the liquid encapsulant itself. The encapsulant material for PV modules alone is already a billion-dollar business worldwide. The early attention to thermal cycling and damp heat exposure testing is commendable.
- This encapsulation approach will only be adopted globally if the cost of the liquid encapsulant material is acceptable. Liquid encapsulants available from other suppliers cost about twice as much as ethylene vinyl acetate, which would negate any benefit from the capital expenditure reduction. Although cost modeling is included in the project plan, no specific information has been provided to support the cost potential of the PPG proprietary liquid encapsulant, nor are there project metrics listed to address key material cost issues such as the required encapsulant thickness.
- The Chinese and Asian players have already figured out how to reduce the lamination step considerably. However, if true, this project could eliminate the lamination step entirely.
- The novelty of liquid encapsulants has been piloted by others elsewhere. It is unclear from the narrative and poster about whether this group recognizes previous barriers and is adequately providing pathways to circumvent those pitfalls.
- There is not much data of the candidate liquid encapsulants cited, making a review of the merit criteria problematic; similarly, there is little information regarding the proposed toolset either in terms of operational performance or capital expenditure to ascertain whether the claimed benefit offset any additional costs.
- This report is very weak on technical details. It is unclear whether this encapsulation technique will be compatible with emerging interconnection technologies (e.g., SmartWire, pre-metallized backsheets, etc.). It is also unclear how and why the liquid encapsulation plays the role of the lamination layer.
- The reliability of the liquid encapsulant is unclear. It would be helpful to know if it tolerates the temperature and humidity tests, and if they can do the testing first.

## PROJECT: 6356 SOLARIA CORPORATION

*Development of Manufacturing Technology to Accelerate Cost Reduction of Low-Concentration Photovoltaic Modules*



**FUNDING INFORMATION** \$2.0M | Solar Manufacturing Technology | 09/2013–09/2015

### Project Description

Solaria will cut costs for its low-concentration silicon photovoltaic (PV) module by automating a number of manufacturing process steps, including the stringing and tabbing step that is used to assemble and align the crystalline silicon (c-Si) strips that are placed under a lensing glass top sheet. This removes a primary barrier to enable Solaria to undertake high-volume PV module manufacturing in the United States.

### Individual Reviewer Comments

- The proposed module design can reduce silicon usage by a factor of 2x, by forming strips from working whole cells and then interconnecting them in a spaced-out fashion. An array of lenses integrated into the top of the module focuses light onto the strips at a 2x optical concentration ratio. If successful, the project and its approach can lower the cell cost component of the module, which is a key component of overall module cost; therefore, it is relevant to the SolarMat program goals. The project/product can also be impactful to the program goals.
- Increased concentration and reduced voltage have good potential in lowering module (and system) costs. In addition, maintaining a flat-plate format allows drop-in replacement of modules in current-day system applications. The stringer, singulator, and layup tools are operational and under debugging and improvements. Alternately, the team also has good experience in low-concentration trackers.
- The project approach focuses on equipment development where automation can reduce labor cost and improve product quality. Equipment engineering/integrator subcontractors are used. This is a standard strategy and approach to equipment development. Therefore, the approach is adequate given the goals of the project.
- The project is funded at \$5 million over 2 years with a 60% cost share. The level of funding may fall short of that required by the scope of tool development. It is also unclear whether the project will save money on the overall leveled cost of energy installed.
- The project requires change from end-module stringing and tabbing to make it feasible.
- Market leaders like SunPower have their own solution (C7), which works better with SunPower-like efficiency.
- Reliability and quality are issues that should be addressed early in the program as joint failure and performance loss to laser dicing are concerns. It is not clear how the module will succeed where sliver cells failed, so it might be worth considering reaching out to or recruiting from the Origin/ Australian National University program.



## PROJECT: 6358 SOLARWORLD INDUSTRIES AMERICA INC.

*Highly Automated Module Production Incorporating Advanced Light Management*

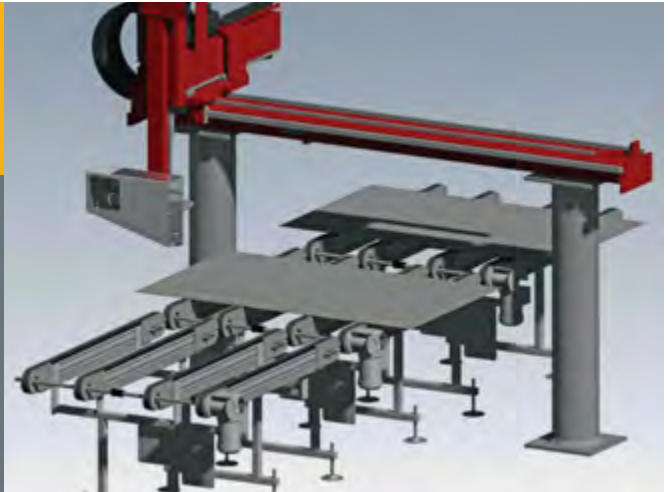

**FUNDING INFORMATION** \$2.4M | Solar Manufacturing Technology | 09/2013–09/2015

### Project Description

SolarWorld will incorporate an advanced light management system into its photovoltaic modules that will achieve substantial efficiency improvements at little additional cost. The light management system reduces optical losses from tabbing ribbon and area between cells and represents a large, unrealized opportunity for module efficiency improvements. The proposed SolarWorld approach cost-effectively utilizes low-cost components implemented using highly automated robotic systems.

### Individual Reviewer Comments

- The project offers a really novel light management approach. It makes logical and technical sense, particularly the approach to using less expensive materials to enhance the solar cell performance. Strengths of the project include a modest power gain, a simple and novel approach, and 3M's deep experience with coated films—success seems likely. Additionally, the project demonstrated a 1.1% increase in module power compared to control modules, and early concepts for tooling and automation were presented. The project also can increase very marginally the efficiency of current front-contact bus architectures.
- The project aims to develop a reflector to redirect light incident on non-active module regions into active regions of the module. The reflector is a slatted, angled reflector that can be placed over busbars and between cells, reflecting light onto the front internal glass surfaces, where it is reflected back down to the cell (for example, by total internal reflection). The project targets an increase in module power of 4.5%, presumably without offsetting power gains with significant cost. Therefore, the project is relevant to the SolarMat program goals.
- The project has 2 main objectives: (1) demonstrate a cost-effective increase in module power with the reflector materials and (2) phase the new materials into production with an anticipated increase in module power of 4.5%. If significant power increase without significant additional costs can be achieved in production, the project will have an impact pertinent to the program goals.
- The project is funded at about \$5 million over 2 years with about 50% matching funds, which is appropriate and adequate for the scope and goals of the project; though, others felt the cost was too high because the project results in very low improvement in efficiency, as the bus-bars are being replaced by multi-wire solutions.
- The project approach is to demonstrate feasibility in prototype modules, then proceed to a pilot-scale evaluation. If successful, the outcomes will be proliferated to a full-scale module facility. This is a straightforward approach; however, the plan seems to be lacking a rigorous and early reliability, quality, and field-testing plan.
- This is an old technique to check for intellectual property (IP). It is hard to protect IP on this kind of light-redirecting film. It is also hard to get the efficiency if the cells are on a single or double axis tracking solution.
- The poster and abstract present conflicting results: 280 watts versus 283 watts for the light-redirecting films; added module complexity and critical alignment of reflector material on cells (overlap and shading will offset power gains); and no prelim or early stage field/reliability testing (e.g., accelerated ultraviolet exposure).

## PROJECT: 6376 FOLSOM LABS

### *Automatic Design Optimization Software*

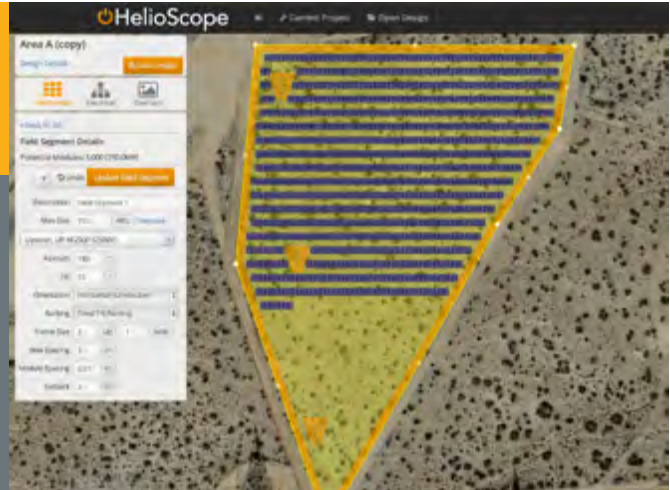

**FUNDING INFORMATION** \$0.35M | Incubator 8 | 01/2014–12/2014

### Project Description

Folsom Labs makes solar array design software that combines advanced performance modeling with cloud-based design tools. Under the SunShot award, Folsom Labs will extend its core HelioScope product to provide automatic evaluation of various system designs and component choices to quickly find the lowest leveled cost of energy approach for a given site.

### Individual Reviewer Comments

- The project offers a very specific subset of large-scale projects. It is expensive relative to the market impact in large projects, but it is also applicable to residential rooftops. The approach—design first—is a good way to save costs. Authors project savings by reducing the design optimization process from 5–15 hours to only 1–3 hours. Overall, this is a good investment for SunShot.
- The amount of savings is partially offset by the learning curve associated with becoming familiar with a new piece of software. In addition, the amount of savings is very small. In order for it to have any impact on SunShot goals at all, it would have to have almost universal adoption by nearly all developers. The number of hours it takes to develop and permit a photovoltaic (PV) project is many times the claimed savings due to this software.
- It is not clear how many of the variables would be accounted for in the analysis. For example, it is not clear if it would take into account the shading of offsite buildings, trees, or mountains, or whether it can

accommodate topological irregularities. If it had to accommodate offsite shading and topological irregularities, the input alone would take longer than the one to three hours claimed.

- The business model is not clear, as it is uncertain who will buy the software and how it will penetrate the market in sufficient numbers to impact SunShot goals.
- The project team is not using top technology, but is utilizing old parameters (outmoded) designed to work with Excel and the AutoCAD process. The team is also small. Though talented, the expertise of bandwidth may be exceeded as the new SunShot award is to bring in a “detailed financial and cost model,” which will take underlying information for electrical design, tracking versus fixed-tilt options, ground-mount design, different equipment costs and equations (market variable), and a regular review of supply chain of costs to allow for correct cost estimates. The team also gives the impression that it is building a company to be an acquisition target.
- The current go-to-market return on investment (ROI) is weak and there is no long-term ROI plan. “Paid seat” will not turn the company into sustainable model.

## PROJECT: 6377 DEMETER POWER GROUP

*PACE3P® Financing Platform:  
Scalable Third-Party Ownership  
Commercial Financing*



**FUNDING INFORMATION** \$0.50M | Incubator 8 | 10/2013–09/2014

### Project Description

Demeter will offer solar lease or services agreement financing collected as an assessment on the property tax bill via its Web-based platform, PACE3P. By securing payments to the property, instead of the offtaker, PACE3P lowers the levelized cost of energy by 20%; makes more deals “bankable” without a corporate guarantee; and enables the first uniform, scalable financing for commercial solar.

### Individual Reviewer Comments

- This project of “bonded financing” tied to home equity is a brilliant idea and another area to show solar is a bankable asset class. Access to capital with simplified auto generation of term sheets, tied to a physical building while working with different capital providers, is a critical and necessary component to solar implementation. This lease model allows for a lower cost of capital over the 20-year lifespan of the loan.
- The project offers a novel financing approach that combines a power purchase agreement with a long-term lease. The security of the property being the anchor for inclusion in property tax bills is a likeable feature. It seems it would have a high appeal to homeowners who are on the fence about how to finance a solar system.
- Funding seems to be low for the impact and the complexities this company faces to launch its financing product line (PACE and other financing vehicles) into government tax billings.
- It is difficult to show per watt installed savings in relation to SunShot goals.

## PROJECT: 6378 BRITTMORE GROUP, LLC

### *Utility-Scale PV Cost Reduction: Panelization for Use with Automated Panel Installation System*



**FUNDING INFORMATION** \$0.68M | Incubator 8 | 10/2013–09/2014

### Project Description

The Brittmore Group will develop and demonstrate an automated system for preassembling frameless photovoltaic (PV) modules into larger panels using construction adhesives. This system will deploy panels across large-scale PV arrays by industrial robots that traverse the mounting rack. This technique promises a significant reduction in construction duration and cost. It is also expected to accelerate market acceptance of frameless PV modules, which further reduces structural materials and electrical installation costs.

### Individual Reviewer Comments

- The full review of the need to panelize onsite is impressive. Brittmore Group seems to be on target with deliverables, and the company seems to fully think and vet its ideas for design, taking into account not only the speed of panel installation, but also the physical environment that the machines will be deployed, allowing for a long-term viability of the machines in use over time.

- It is impressive that the team is both producing the machine and owning the process for installation (they are their own end user).
- There is a potential of continual “innovation” and re-tweaking of robotics and not getting production capabilities out to market in a timely fashion as a weakness. The team can go back and improve in iterations of machines.
- There is a long-term risk of adhesive and testing over time of panel attachment to rail.

## PROJECT: 6406 RENEWABLE POWER CONVERSION

### *Macro-Micro PV Inverter Commercialization*

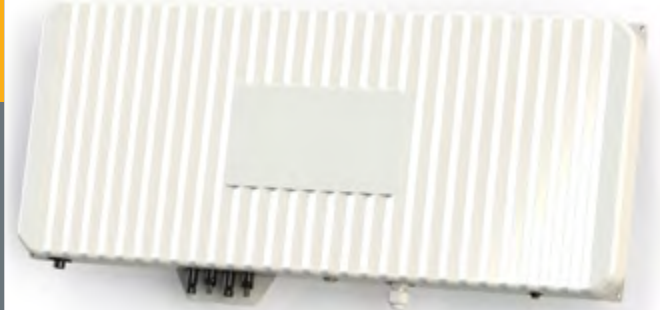

**FUNDING INFORMATION** \$1.0M | Incubator 8 | 10/2013–03/2015

### Project Description

Renewable Power Conversion will produce an environmentally sealed inverter featuring plug-and-play installation/replacement and a maintenance-free lifetime equal to that of photovoltaic (PV) modules. The Macro-Micro is a modular 17-kilowatt inverter that enables high system granularity and redundancy. Power is efficiently converted and collected with an inverter efficiency of 98.5% and system power collection at 600 Vac. This distributed multi-string inverter provides multi-megawatt PV projects with a low levelized cost of energy alternative to large central inverters.

### Individual Reviewer Comments

- There is high value for market (mid-market and utility scale) if full system value proposition of alternating current inverter (less than direct current for parts and installation, and smaller cables, etc.), three-phase combining in field, and longevity were to be clearly defined and monetized for cost savings at installation point and life of system. This is a great product that is designed to have an extended lifecycle.
- The turnaround time to market is a weakness of the project. UL or Intertech could be roadblocks for cash-flow timing to market.
- The project did not seem to have a full value proposition or value walk focused on this single product. No targets were identified in the market segment for future sales (no user requirements or customer feedback for potential design necessities such as mounting, etc.).

## PROJECT: 6407 GEOSTELLAR

*Solar Data Everywhere*



**FUNDING INFORMATION** \$0.75M | Incubator 8 | 10/2013–03/2015

### Project Description

Geostellar will streamline the procurement, financing, installation, and maintenance of solar arrays with the creation of a Solar Project Record. The Solar Record provides application developers with important data, including the estimated cost of solar energy production on a particular rooftop, utility rates, load profiles, incentives, property ownership, equipment configuration, installation, and permitting requirements for individual properties across the United States. This tool will be available to homeowners, installers, government agencies, and financing companies through Web and mobile applications.

### Individual Reviewer Comments

- The authors have already developed an attractive Web page with considerable functionality to perform financial calculations based on local insolation, utility rates, and subsidies and simplified assumptions about project conditions. There has been good customer traction.
- Most of the leading solar installers and power purchase agreement companies already have their own solution. It is unclear that another marketplace of inaccurate designs is helpful, but the JavaScript Object Notation report might be.
- It is hard to have a differentiated and sustainable solution that others cannot copy.
- The goal of creating a Solar Project Record that would be transferable from owner to owner over the life of the structure and be made available to real estate agents seems to be a solution looking for a problem. It is not clear that the industry is seeking this feature.
- This reviewer recently purchased a rooftop solar photovoltaic system for his/her personal residence. The reviewer logged onto the Geostellar Web page to see how his/her estimates compared with the actual costs and projections for the residence. The online estimates could not (did not) take into account the pitch of the roof, the azimuth of the roof's surface, or local shading, nor could it determine whether installation on a particular surface of a residence's roof would provide sufficient space for the recommended number of panels. The system also omitted the effects of simultaneously upgrading existing heaters and air conditioning equipment to simultaneously harvest tax and utility incentives and subsidies. The resulting cost projections varied widely from actual results. While the idealized online estimates were very attractive and interesting, a specific local examination would still be required.
- The product seems relatively cheap if it is something lots of installers used. However, it is unclear why and how they would. In addition, the authors failed to describe how the money would be utilized and what the investment would buy. They also failed to show how the SunShot goals of reducing the localized cost of solar power would be accomplished.

## PROJECT: 6408 CLEAN POWER RESEARCH

*Development of a Cloud-Based Interconnection Business Process Management (BPM) Software Solution*

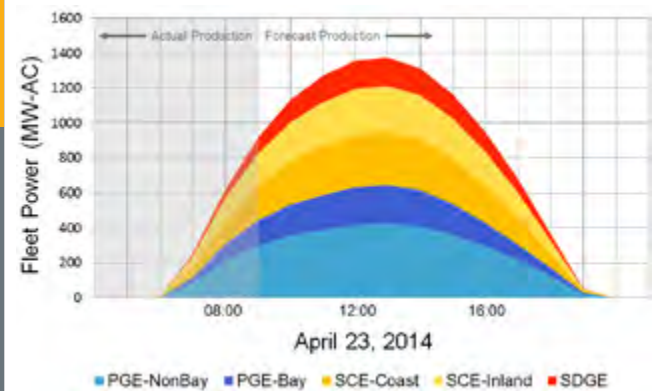

**FUNDING INFORMATION** \$0.94M | Incubator 8 | 10/2013–03/2015

### Project Description

Clean Power Research is developing the next PowerClerk® platform to significantly reduce soft costs associated with interconnecting distributed solar to the utility grid. By taking the interconnection process online and automating communications, application submission and review will be streamlined, and sophisticated solar retailers will be able to apply for interconnection directly from their proposal tools. Additionally, the platform leverages information collected in PowerClerk in a solar engagement tool that utilities can use to engage their customers early in the solar sales process. This interactive online tool will allow utility customers to see how many of their neighbors have gone solar, explore personalized economics of solar, and connect with installers and financing.

### Individual Reviewer Comments

- The software promises to streamline the work of utilities in integrating new residential solar customers by taking a manual and paper-based system into a paperless cloud-based process. This would save the utilities and developers some money. The project addresses some of the key high-value problems of reducing net system installed cost by using software to simplify.
- The project team is engaged with utility companies, and the project funding level appropriately supports the impact. Clean Power Research seems to have a good track record of solutions. This will achieve the objectives of the SunShot program.
- Interconnection is key and under-attended to part of the problem.
- The proposed savings would not significantly impact the SunShot goals of materially reducing the levelized cost of energy of new photovoltaic systems. In addition, streamlining the developer and utility processes would not likely reduce the system cost to the consumer by a significant amount.
- The cost to fund the further implementation seems disproportionate to the benefit received by the U.S. Department of Energy. Moreover, most of the leading solar power purchase agreements and solar companies (SunPower, SunEdison, FSLR) have their own solutions.
- It is unclear what the sustainability or differentiation is with other players.

## PROJECT: 6413 INFINITE INVENTION, LLC

### *Solar Socket*



**FUNDING INFORMATION** \$0.50M | Incubator 8 | 10/2013–03/2015

### **Project Description**

Infinite Invention is developing the Solar Socket, a device for plugging in solar photovoltaic between the electric meter and meter case. The device streamlines the installation process by reducing wiring costs, scheduling requirements, and site inspection time, and allows for swapping in new technologies as they emerge. In addition, a version with onboard metering and communications lets power flow directly into the utility grid.

### **Individual Reviewer Comments**

- The team appears strong, innovative, and committed. Alliances with industry leaders seem identified and they are in pursuit.
- The supply side or demand side disconnect option is of value in market adoption. In addition, the project's innovative design includes the potential for storage and generators, though space in unit and heat buildup may become a problem.

- The standardization is likeable, but it is unclear that it works as a technology. Assuming it gets listed, this project could help reduce costs on a lot of solar homes and have a high impact.
- Heat buildup inside solar to meter socket integrator is a concern. Potential challenges on signal for communications and sensing are also present.
- The value walk is questionable—the cost to manufacture and how to get to market should be further pursued.



## PROJECT: 6414 APPLIED NOVEL DEVICES, INC.

*Manufacturable High Efficiency (>20%) Interdigitated Back Contact Solar Cell Technology Using Si Heterojunctions*

**FUNDING INFORMATION** \$0.50M | Incubator 8 | 10/2013–09/2014

### Project Description

Applied Novel Devices is developing a low-cost, high-efficiency interdigitated back contact (IBC) solar cell technology using a novel self-aligned direct patterned deposition system. The process for forming the cells eliminates the expensive multilevel patterning and alignment needed for conventional IBC cells. This technology is applicable to both implanted and heterojunction (HJ)-based IBC cells.

### Individual Reviewer Comments

- This project addresses a key barrier to IBC/HJ technology hybrid structures—it uses direct write to potentially eliminate expensive patterning consumables and steps. It correctly identifies the state of art and potential customers for process validation, and it has started partnership conversations. In addition, the capabilities of laboratories and researchers are complimentary in nature, and collaboration should be fruitful.
- HJ IBC cells have recently attained world-record efficiency for silicon at Panasonic, and in principle this cell structure is likely to remain the performance leader for silicon. For that reason, it will always be a legitimate subject of investigation for its scientific value. This structure will become interesting in the event of a very clever innovation that simplifies its fabrication. Applied Novel Devices proposes direct patterned deposition of amorphous silicon using a silicon mask, and initial trials using this approach have been performed.
- The record efficiency at Panasonic is only 1% (absolute) higher than the company previously attained with a much simpler two-sided HIT (Heterojunction with Intrinsic Thin layer) structure. There is no indication



that Panasonic considers the IBC version of its HIT cell to be cost effective to manufacture. Although Applied Novel Devices proposes a lower-cost approach, this project team seems to be starting from about the point where Sanyo/Panasonic was 20 years ago. Panasonic has poured about \$100 million into development of its HIT cell, compared to \$500,000 for this project. This project is more than halfway through, and it has not yet produced a functional solar cell of any structure, so it seems highly unlikely that this project will meet the project objectives within the funded time frame.

- It is unclear which group will be responsible for delivering what key element, especially Texas and the Georgia Institute of Technology. Also, cost-reduction pathways are not specifically outlined or delineated in the proposal, especially if performance gains are not present to offset additional capital expenditure.
- Current performance does not yet meet or exceed competitive or incumbent technologies it is looking to displace; in fact, a volatile organic compound penalty looks to be paid when compared with Tier 1 HJT devices, without a corresponding increase in short circuit current from IBC, so some work is still needed to validate additive gains of structure.

## PROJECT: 6457 SMASHsolar

### SMASH HIT

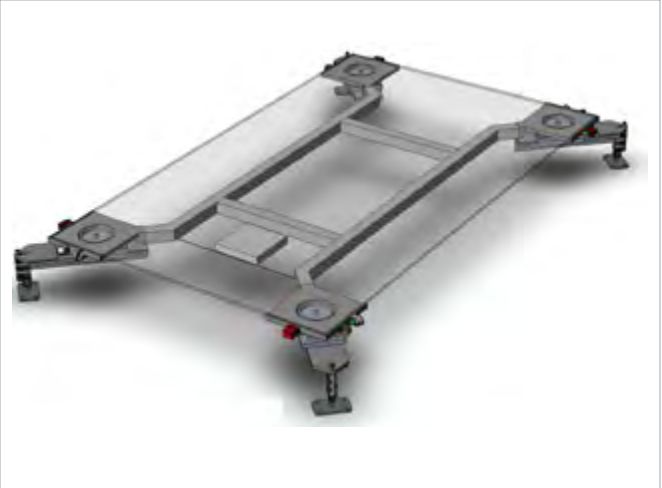

**FUNDING INFORMATION** \$0.50M | Incubator 8 | 10/2013–09/2014

### Project Description

SMASHsolar is developing a scalable photovoltaic mounting system that installs in half the time with half the parts and allows an array to easily expand over time. This project will develop and test an integrated mounting system that shifts field work to the factory, resulting in a simplified installation process that drives down balance-of-systems costs.

### Individual Reviewer Comments

- The project is in the early stages of development and the team is committed. There is good backing with partner Xerox (parc) and could be potential for innovation to be added for wire management (not addressed).
- A hardware fix does not need to be supported by SunShot. Then again, Zep has helped address a lot of cost in the system. Preassembly prior to assembly on the roof is a good product installation model. The simplified installation and training are pluses, but training of installers should include roofing best practices.
- Even though this is a very early concept, there is no backend costing and/or manufacturing costing. To date, only raw prototypes have been provided. The teams needs to define the tooling cost of going to market, cost of goods sold, and the ability for market penetration with sustainable business margins (final selling cost for market unknown).
- Flashing was not included in the design scope, which featured multiple penetrations per panel installation (high risk for leaks) that are still in stages of development and may be designed out.
- The product is sheathing mounted (as opposed to structurally mounted), which may pose a problem in multiple jurisdictions in the United States.
- The installation time trial was not a clear indicator of the SunShot goal of labor cost reduction, as the install utilized a basic advantageous design layout to their system (needs multiple configuration time trials for accurate reading). The value walk for \$0.31 savings was not clearly defined (\$0.15 “increased throughput” specifically).

## PROJECT: 6459 SINEWATTS

### *Single Silicon IC Photovoltaic Inverter*

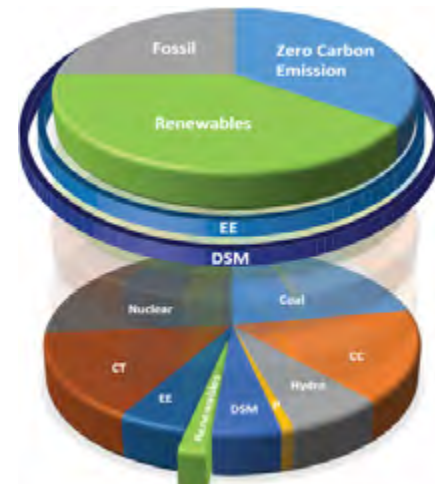

**FUNDING INFORMATION** \$0.50M | Incubator 8 | 10/2013–09/2014

### Project Description

SineWatts is developing an inverter architecture that is 10 times smaller, 100% siliconized, and 70% lower in installed cost. The SineWatts Inverter Molecule™ is a single silicon integrated circuit (IC)-based distributed inverter co-packaged with its photovoltaic (PV) panel and is of the footprint of an iPhone. SineWatts' patent pending architecture allows the molecules to utilize advanced silicon power-switching technologies developed for mobile applications to be utilized for grid-supportive, highly reliable and dispatchable PV power plants.

### Individual Reviewer Comments

- The project is very innovative and will allow for dramatic labor savings and product cost savings, and long-term maintenance and monitoring is embedded in product design. It is one of the most innovative products within these categories of reviews. The project also has a strong, committed team. The SunShot value walk is proposed and goals are aligned.
- The project seems like a heavy lift, but it would be good if it works. The project also seems cheaper than some other ideas. This is the kind of breakthrough the U.S. Department of Energy should back.

- The team appears to need some business acumen to further fund externally its project. A lack of personnel bandwidth on this project will delay fruition. In addition, challenges lie ahead on converting to a micro process.
- An underfunded award as this is a critical path to SunShot goals. The project may have difficulty with external funding, as venture does not understand the ramifications of this product and the team may have difficulties explaining the value walk in the market.

## PROJECT: 6461 SILICON SOLAR SOLUTIONS

### *One Step Super Emitters for High-Efficiency Solar Cells*

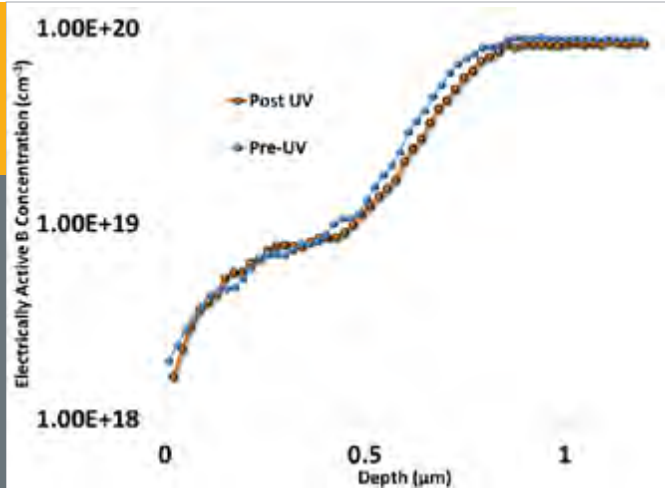

**FUNDING INFORMATION** \$0.50M | Incubator 8 | 10/2013–09/2014

## Project Description

Silicon Solar Solutions—in partnership with Georgia Tech and Roth & Rau—is developing a hydrogen treatment to optimize the emitter of n-type solar cells, resulting in improved conversion efficiency and reduced silver gridlines. The technology has shown 15% relative efficiency improvements while using one-third less silver grid lines in the laboratory. The goal of this project is to demonstrate the technology on commercial solar cells.

## Individual Reviewer Comments

- This project correctly addresses a key passivation/metallization barrier for n-type devices (B emitters) and attempts to displace high-cost consumable (silver) through the use of H-patterning during/post dielectric deposition, which would compress unit operations. It builds on work from others in the multi-crystalline silicon space (UNSW) and heterojunction technology space (Meyer Burger) and extends into passivated emitter, rear totally-diffused structures.
- Spectral and surface metrics are appropriate to measure the technology's contribution to device, and they are indicating promising results.
- If n-type wafers approach cost parity with p-type, there will be a major shift in the industry toward n-type cells, and most of these will have a boron-doped front-surface emitter. LG has commercially introduced a selective boron emitter in its NeON module and demonstrated excellent performance, which validates this approach.

This project aims to form the selective emitter in a self-aligned process that should reduce the cost of this approach. The use of hydrogen to deactivate the surface boron while using the metal gridlines to mask the contact regions is innovative and based on sound scientific principles.

- As noted by the project team, diffusing hydrogen through the silicon-nitride antireflection coatings is challenging. The project does not disclose its method of hydrogen introduction, so there is insufficient information on which to gauge the likelihood that they will succeed, but it seems possible in view of previous efforts to diffuse hydrogen through similar materials, such as highly defected polycrystalline silicon.
- The project relies on non-U.S.-based tool vendors for CoO and dissemination and scale-up of technology. In addition, performance demonstrated to date does not meet or exceed competitive or incumbent technology. In fact, the baseline cell is significantly disadvantaged, making for an unfair comparison to be drawn.
- Information provided in the narrative and poster does not adequately illustrate the beneficial tradeoff of capital expenditure and cost of goods sold versus performance enhancements; only qualitative arguments are given.

## PROJECT: 6462 KWH ANALYTICS

### *Aggregated Solar Asset Data for Efficient Financing*

**FUNDING INFORMATION** \$0.45M | Incubator 8 | 10/2013–09/2014

### Project Description

kWh Analytics aggregates historical data on photovoltaic system performance and financial credit. Combined with a cloud-based storage system, parallel computing architecture and Bayesian statistics, kWh Analytics reduces third-party financing costs by offering highly scalable investment risk analytics.

### Individual Reviewer Comments

- Benchmarking for investors in solar is a critical component to making the solar industry a bankable, risk-averse industry in banking and insurance models. The asset class of panels and inverters will allow for clear and transparent industry knowledge. This company directly supports the solar industry and fulfills SunShot goals with very valuable cleaned and validated data sets.

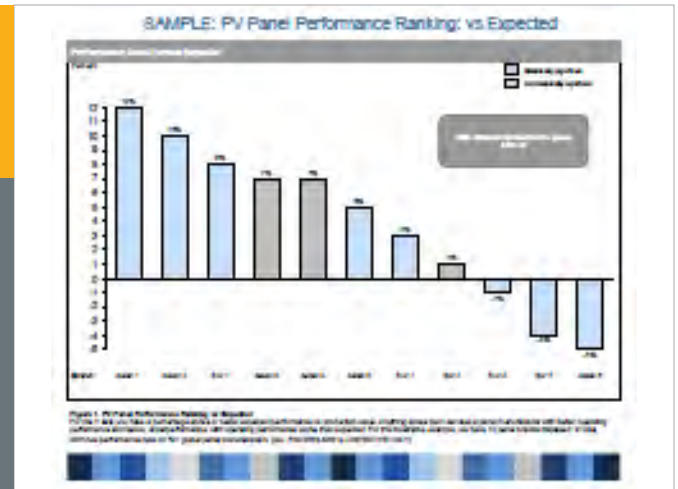

- This work is good, but it seems expensive to generate. In addition, identifying who is their customer and monetizing that was a challenge. This company's end goal is to be acquired by another research company (such as CoreLogic). Return on investment is not built in their business model for sustainability, and it is hard to put a value to the impact on the soft costs.
- This is a small company with no succession plan.

## PROJECT: 6463 SUN NUMBER

### *Sun Number Commercialization Project*



**FUNDING INFORMATION** \$1.0M | Incubator 8 | 10/2013–03/2015

### Project Description

Sun Number is analyzing rooftops to determine the best roofs and the best locations of roofs for solar. This data is used to create Sun Number Scores—a tool to educate consumers about the solar potential of their homes. This data is combined with other information about the roof and the building to qualify properties and lower the cost of customer acquisition.

### Individual Reviewer Comments

- The market needs a simplified customer view of their solar potential with easy access to solar value and implementation. The number identified to home for consumers is not clear on “what” it represents, but gives a strong general impression for consumers and will allow for additional conversation on energy needs and usages.
- Low-cost, readily available solar access assessment is an important enabler for rooftop solar penetration. This team previously applied its approach to 6 million buildings, and has already extended that to 20 million buildings across 45 cities in this project. The project focus on improving the algorithms to predict shading by adjacent structures and the inclusion of facet angles is important.
- The value proposition is missing for the funding level. The methodology to test the accuracy of valuation of house is not being addressed, as there is no loopback for metric or results. Data being utilized are inaccessible to the public (supplied by research laboratory), so no cost projection of data was available. In addition, no value walk could be made regarding SunShot soft-cost savings. The return on investment from lead generation did not appear to support the backend data work necessary to bring this product to market in a sustainable manner; many players already exist in this field doing the value walk for their consumers to drive financial services, installation services, etc., as part of their business model.
- Despite the large amount of data collected thus far, no information is provided about the quality of these data. It does not matter how inexpensive the approach may be if it does not produce numbers that are widely adopted, and they will only be widely adopted if they have real value. It is unclear that the data set will ever be used.

## PROJECT: 6464 ENERGYSAGE

*Consumer Destination Site for PV Featuring a Reverse Auction Online Marketplace*



**FUNDING INFORMATION** \$1.2M | Incubator 8 | 10/2013–03/2015

### Project Description

The EnergySage Marketplace transforms the complex solar photovoltaic (PV) shopping process into a simple, online comparison-shopping experience. The unique, innovative platform provides unprecedented levels of choice, transparency, and information at no cost to consumers. Consumers can compare quotes from multiple, prescreened installers in a consistent matrix format across all financing options. EnergySage reduces time and effort for both consumers and installers, significantly reducing customer acquisition costs, boosting consumer confidence, and accelerating mass market solar adoption.

### Individual Reviewer Comments

- The educational need for solar comparison is high, and the ability to find a trusted solar installer for bid comparison needs simplification. This product does not address true consumer installation and financing issues, but rather focuses on awareness.
- The proposed software promises to aid the end consumer in a reverse auction process that will yield reduced capital costs. The price reductions may not be real in past experience—Greentech Media may not be accurate. It is also not clear that this will lead to significant reductions in levelized costs of energy. This seems to be a low-margin enterprise with competition from similar software products.
- It seems that the technology does not justify a \$1.25 million grant, as there is no “secret sauce” in the process. Competition already exists in this marketplace, and if the project was a sustainable business model, it would be able to stand on its own. There does not appear to be a sustainable return on investment, and no ability to collect on installs or referrals. There is a high risk on survivability.
- The business model has screened installers “pay to play,” but it is unclear who is liable if something goes wrong with the install. This focus is stepping out of the company’s core competency, and the project seems to be a victim of “scope creep” trying to find a niche to monetize. This will damage the solar reputation business model in the long run, as pricing pressure is not based on a website’s view but on economic pressure.
- When requested, the project team did not have a value walk to monetizing the product. It would be helpful to know if there is a caveat regarding inaccurate savings projections or cash-flow graphs. This power projection needs to be accountable to the installation company and not disjointed from the installer ability to put solar on a roof (physical obstacles to installation or unaccounted for solar installation obstructions). There are several holes in the process from education to contractual solar installations.

**PROJECT: 6465**  
**SOLAR CENSUS, LLC**

*The Final Breakthrough in  
Solar Mapping*

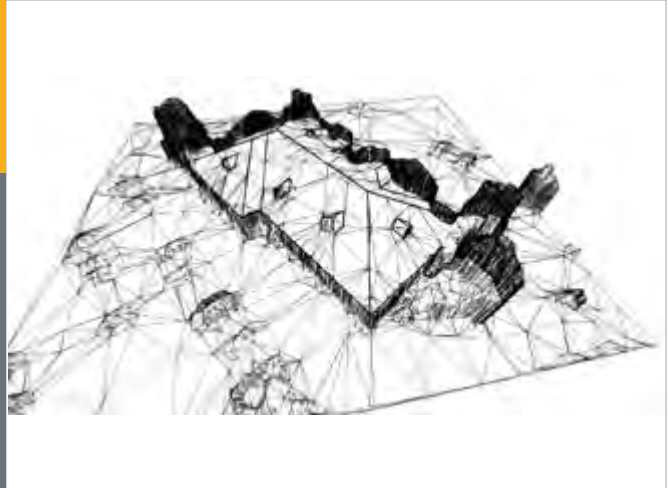

**FUNDING INFORMATION** \$0.73M | Incubator 8 | 10/2013–11/2014

## Project Description

Solar Census will leverage its patented algorithms to produce the first commercial-grade online shade tool that enables salespeople and system designers to customize photovoltaic systems in 3D and create highly accurate quotes in minutes. The software will streamline the sales and design process, reduce change orders and soft costs, and increase close rates and homeowner satisfaction.

## Individual Reviewer Comments

- The project is cost effective and a good response to the criteria. This could be relatively easily integrated into existing business models; therefore, it is a cool tool. The entrepreneurs have a good plan to make it work for their customer targets.

- There is a clear need to streamline the solar resource assessment of sites. Using aerial imagery seems like a feasible approach, and the principal investigator for this project is clearly well-versed in this subject. It was pleasing to see via the UPTO website that the two key patents were finally assigned by the inventor to Solar Census in March of this year.
- The company is still in the process of acquiring the necessary high-resolution 3D images. The relatively high cost of the approach taken precludes using this method as a screening tool for customer acquisition.



## PROJECT: 6466 SIMPLY CIVIC

### *Application to Streamline Solar Soft Cost Processes*



**FUNDING INFORMATION** \$0.40M | Incubator 8 | 10/2013–03/2015

### Project Description

Simply Civic is developing an online solar project application that will be available to jurisdictions nationwide. The tool will seamlessly enable jurisdictions and installers to track the status of solar projects while making it faster and simpler to complete required paperwork.

### Individual Reviewer Comments

- This project is an excellent concept that is low risk on technology expertise with great reward to all levels of the authorities having jurisdiction (AHJ) process. Strengths include the project offering a Web-based platform and learning software, and that it is open at both ends. Reducing the processing costs of AHJs might speed the approval, and possibly the processing costs, of new solar applications.
- The team's sales process for market penetration mentality by awardees to progress widespread adoption is excellent. The value proposition is high for large city application. In fact, application can dramatically improve the solar "impression" of paperwork load to AHJs and decrease permitting costs.
- This product/process could be extrapolated to all areas of AHJs and government administrative processes when interfacing with the public. There is a strong sense of knowledge on return on investment and cost associated with getting a product to market. There is a high risk on overall adoption, but the risk is very worthwhile and seems to be well received.
- The author has not quantified how the adoption of his software by approving authorities materially reduces the levelized cost of electricity. There is insufficient detail and virtually no quantification on the benefit of the proposed software to developers and customers. It is also not clear what benefit the U.S. Department of Energy derives from this grant, except for the intangible acceleration of AHJs processing of applications.
- There is a long curve to adoption, as AHJs are slow movers. Other weaknesses include slow cost reduction and low funding for the impact it can have on industry.

**PROJECT: 6468**  
**SUNRUN**

*End-to-End Workflow Automation for Solar Project Development*

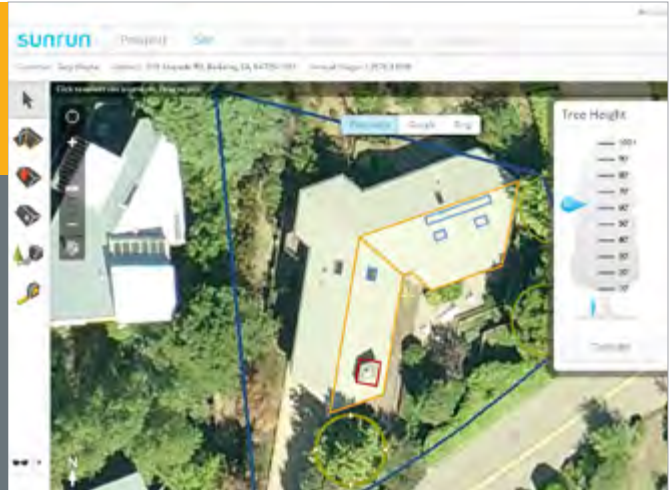

**FUNDING INFORMATION** \$1.6M | Incubator 8 | 10/2013–03/2015

**Project Description**

SunRun is creating an integrated system for automatic design, costing, simulation, proposal generation, pricing, permitting, and field change management for a photovoltaic (PV) system. This end-to-end platform will optimize system performance and greatly reduce project cost and lead-to-cash process time.

**Individual Reviewer Comments**

- Automation of project planning, especially for residential systems, is a critical enabler for PV penetration. SunRun is certainly well-suited to address this issue and is highly relevant with a strong impact in the marketplace. SunRun takes the “silos” out of the solar sales and installation process.
- The approach taken is comprehensive. Benchmarking the results (especially of shading analysis) against traditional onsite assessment, as already demonstrated, is essential for wider acceptance of this technique. The protection of intellectual property (IP) through

patenting is commendable, as ownership will encourage continuous improvement.

- Automation could be significant in costs savings. However, it is unclear as to how this will be shared with contractors, so it is hard to determine what overall savings will be. Funding also seems high for an established market installation/funding leader.
- Insufficient information is provided to justify the claims of soft-cost reduction from this project, which seem to be somewhat exaggerated. No mention is made of how the approach being developed is superior to competing efforts to develop end-to-end workflow automation (e.g., SunPower or SolarCity).
- The program seems complicated and IP seems to be tied to one person. There is also a risk to the software not being available to the wider market, and it will face a possible barrier to entry for mass market adoption.

## PROJECT: 6529 GENABILITY

### *Genability's Verified Solar Savings*

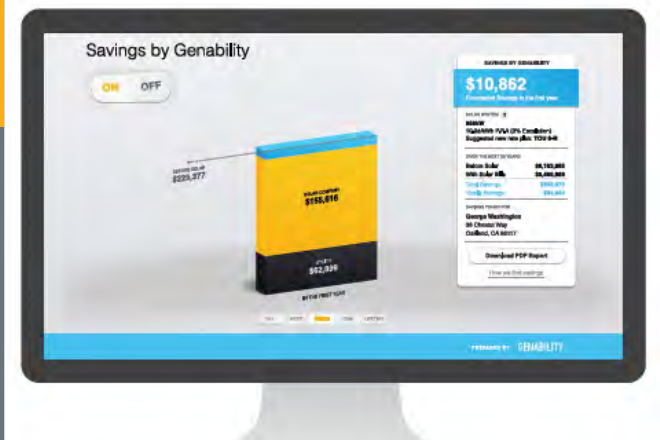

**FUNDING INFORMATION** \$1.0M | Incubator 8 | 03/2014–09/2015

### Project Description

Genability is implementing an independent analysis of projected and actual solar savings and a monthly savings statement that automatically tracks actual savings, compares actual with projected savings, and determines the optimum rate plan for customers. The “Verified by Genability” mark will help to lower bid preparation costs and time and increase lead-to-customer conversions.

### Individual Reviewer Comments

- The author proposes to develop software that will act as a second opinion or a verification of the developers’ estimates to aid the end consumer in predicting the performance of a proposed photovoltaic (PV) installation, thereby speeding sales closes. They want to establish a quality certification label similar to UL-approved products. The project helps simplify understanding of savings for the end user.
- Opinions on funding were mixed. One reviewer felt that the funding seems excessive to further develop the product. Another felt that funding matches the capability required to make this program.
- This project covers an important component of the calculations required, but may be more than needed on one end and yet insufficient on the other. This is not a high-impact project. Most of the solar installers and power purchase agreement companies have this capability, and there is no differentiation or sustainability of the solution.
- This product seems to help deployment of PV systems rather than directly reducing leveled costs of energy.

**PROJECT: 6530**  
**SOLARNEXUS, INC.**

*Next-Generation Workflow  
Platform and Ecosystem for  
Solar Applications*



**FUNDING INFORMATION** \$0.50M | Incubator 8 | 03/2014–05/2015

## Project Description

SolarNexus and its partners will integrate a range of software used for customer acquisition, system design, permitting, and monitoring—resulting in the industry’s first ecosystem of interoperable software applications. The integration of key functionality from separate software vendors will significantly eliminate data reentry and enhance the productivity of solar professionals with a simplified software experience. The ecosystem will leverage the Integrated Energy Project (IEP) Model ([iepmodel.net](http://iepmodel.net)), an existing, publicly available data standard for the transfer of solar project information.

## Individual Reviewer Comments

- This project has high potential to change the way permits are granted by local jurisdictions. Anything that makes it easier on city and county officials to evaluate solar installations has a high payback in both efficiency of deployment, but also creating a base of understanding that will serve the industry well.
- This project is building on a tool originally designed by the California Solar Initiative. It is an innovative idea and a defined attempt at helping to ease the processes that are in silos otherwise.
- This is an early-stage project. The business model may not be able to sustain itself if any of the team’s software partners change or consolidate. The value chain is therefore vulnerable with such few partners in their proposition.

## PROJECT: 6540 CELLINK CORPORATION

### *Interconnect Circuit Reliability and Scale-Up*

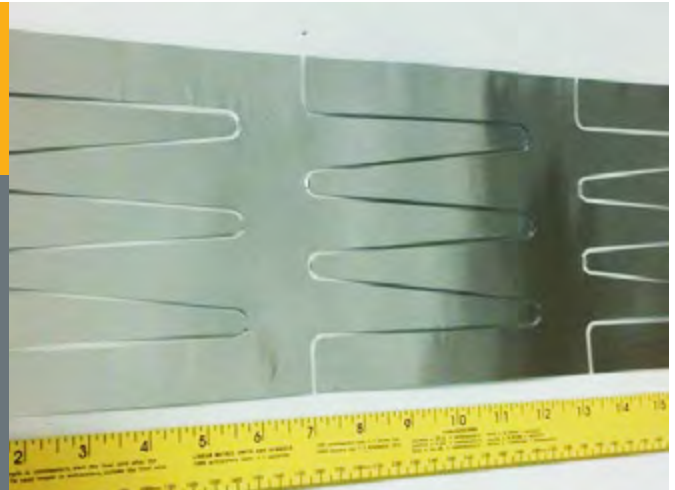

**FUNDING INFORMATION** \$0.70M | Incubator 8 | 03/2014–03/2015

### Project Description

Cellink Corporation is creating an interconnect circuit that will be used to interconnect back-contact solar cells. The circuit is a standalone, simplified flex circuit that will be used in place of the back encapsulant in a back-contacted solar module. This product will reduce the costs of manufacturing silicon modules by 10%.

### Individual Reviewer Comments

- Back-contact cells such as metal wrap-through (MWT) have failed to have an impact, primarily due to the high cost of integrated conductive backsheets. This project aims to reduce the cost of these sheets through substitution of aluminum for copper metal and use of an undisclosed conductive adhesive, which are indeed the major cost drivers. The project addresses a clear barrier in megawatts thermal (MWT) implementation at high volume.
- Cellink solves the critical issue of the high cost of back-contact sheets for the MWT architecture. The \$4/meter squared if achieved can drive adoption of the MWT architecture. The project offers a creative and novel approach to fabricating a metallized backsheet interconnection for rear-contact devices that can be applied to interdigitated back contact, passivated emitter, rear totally-diffused, heterojunction technology, and others if successful. The project provides an excellent market survey and identification of its user base, with key requirements clearly in focus for the project.
- The project has a good team and partner in D2Solar to try the experiment in a low-cost manner.
- Funding is probably suitable for just prototyping; additional funding will be required to qualify an end customer. Very few customers have adopted the MWT architecture because of the high cost of the backsheets.
- There is concern that the cost structure of connects/ backsheet hybrid will significantly eclipse that of incumbent techniques, making any incremental performance gains un-economical.
- Module efficiency demonstrations to date fail to meet or exceed state of the art for conventional interconnection methods. In addition, reliability data illustrated in the program thus far are incomplete to formulate an assessment of durability and reliability and need further time and work to validate.
- Enforcing intellectual property will be tricky if using third-party manufacturers or licensing the technology to cell or module manufacturers.
- Although Cellink claims that the company's approach will increase module efficiency by 1.5%, a more realistic expectation is 1.0%. With this performance benefit, the conductive backsheet would need to cost no more than \$15/meter squared, which is 25% less than the \$20/meter squared of currently available backsheets. The information provided by Cellink is limited to protect its intellectual property, which therefore provides insufficient information on which to determine whether the company has, in fact, found a path to produce conductive backsheets at this cost.

## PROJECT: 8238 MICROXACT, INC.

### *Real-Time PV Manufacturing Diagnostic System*

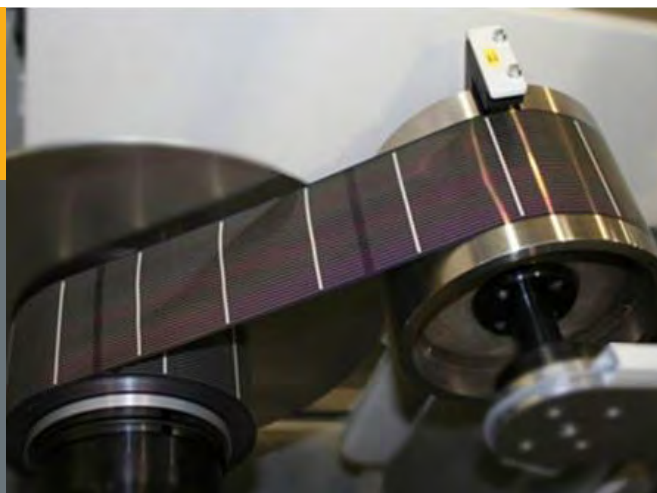

**FUNDING INFORMATION** \$1.0M | Small Business Innovation Research 2 | 08/2013–08/2015

### Project Description

The application of in-line diagnostics to photovoltaics (PV) cell manufacturing lines with high production capacity (greater than 10 megawatts per year) has the potential to significantly increase productivity and reduce costs by improving yield. In this Phase 2 project, MicroXact, Inc. is developing and demonstrating a high-throughput, in-line PV manufacturing diagnostic system that provides data on the spatial uniformity of thickness and refractive indices of thin films as they are processed in a roll-to-roll configuration. The retrieved information will provide the opportunity to detect a wide variety of processing errors, including—but not limited to—thickness/composition inhomogeneity, non-uniform scribing, thin film stress, cracking, and layer separation.

### Individual Reviewer Comments

- The project is tackling high-value problem of copper indium gallium diselenide (CIGS) layer uniformity. The approach is novel and has shown promising early results. If successful, the technique can lead to a commercially relevant tool for diagnostics, failure analysis, and process control. There were good initial image results, broad applicability, tight project focus, and initial results in Phase I. Good spectral resolution was demonstrated.
- This tool can really help thin film roll-to-roll processes with yield enhancement and production diagnostics. It will be incredibly useful to companies like Solopower and Miasole. It seems it could be adapted to other commercial roll-to-roll industrial processes.
- The project aims to develop a scanning method based on spectrophotometric reflection, with high-speed, high-spatial resolution and wavelength resolution. The high-speed, spectrophotometric reflection approach seems to highlight film defects, a capability that will likely prove beneficial in process development, failure analysis, and eventually for process control.
- The Phase I program demonstrated good capability in terms of speed and resolution; the Phase II project is underway to develop a tool for benchmarking in situ at the PV Manufacturing Consortium. The project aim is relevant to the Small Business Innovation Research/ Small Business Technology Transfer program goals.
- If successful, the project can pave the way for a commercial measurement system, which will have an impact pertinent to the program goals. In addition, the project is funded at \$1.1 million over 2 years, which is appropriate and adequate for the program goals.
- Having an aggressive plan to get tools into multiple users, laboratories, and factories would help speed product development, provide good customer feedback, and guide business development.
- The roll-to-roll flexible PV market has not taken off, so the market may still be far off. The CIGS market is still spotty.

## PROJECT: 8281 TAU SCIENCES CORPORATION

### *Apparatus for Optimizing Photovoltaic Solar Manufacturing Efficiency through Real-Time Process Feedback and Spectral Binning of Cells*

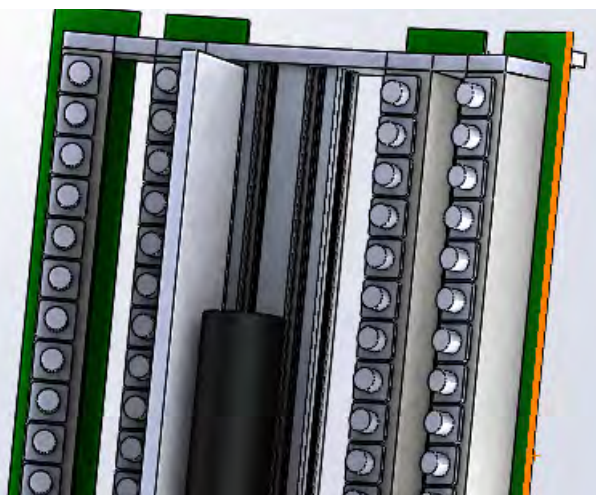

**FUNDING INFORMATION** \$0.98M | Small Business Innovation Research 2 | 8/2013–8/2015

## Project Description

Solar cell manufacturers lack immediate feedback on key process steps such as junction formation and film deposition. This gap is particularly impactful when an offline sampling plan cannot be easily implemented. Furthermore, manufacturers measure cell performance in-line under white light conditions, but are unable to obtain cell response as a function of wavelength without extensive offline testing. Tau Science Corporation is developing non-contact, electrooptic techniques to extract semiconductor bandgap and full spectrum photoresponse. Expected commercial applications include module scanning for failure analysis, cell spectral sorting, in-line monitoring for absorber/emitter quality, and substrate contamination and surface preparation control.

## Individual Reviewer Comments

- The technical approach is novel and excellent. The approach addresses the key issues, the path to a commercial product is clear, the potential impact is clear, etc. The main approach to speed and signal-noise ratio is wavelength parallel illumination using staggered modulation frequencies with Fourier analysis to back out the cell's response to individual wavelengths. The approach is clever, approaching brilliant, and has excellent potential for a breakthrough in this type of measurement. Integration of this novel approach into a functional and useful system will be straightforward. The project team has a good track record of hardware/software engineering and integration. The approach to contactless measurement is interesting, and although it is not clear that it can work, it is worth exploring, and the project team could very well come up with a good

solution (the concern here is that traditional quantum efficiency (QE) measures current, which is linear with good gain, and contactless measures voltage, which is natural log with poor gain). The approach of improving the QE speed by use of light engine is a good approach. It needs to be balanced by tradeoff costs.

- This is a long-needed technique for evaluating production and reliability of solar cells and modules. It will help analyze and match cells in a module for less hot-spot susceptibility and will allow manufacturers better insight into how uniform both the cells and modules are performing with great process feedback to the ingot production and diffusion steps.
- The project aims to develop a full-spectrum QE/R tool capable of high speed and scanning with white light bias, and also of cell-in-module measurements. The project title mentions spectral binning, although it's hard to imagine how this would be beneficial more than the standard QE analysis. QE/R is broadly applicable for solar cell analysis, including AR properties, texture properties, carrier collection, rear reflection, and more. Therefore, a fast-scanning QE/R capability would be broadly applicable in photovoltaic (PV) research and development (R&D), failure analysis, product engineering, and process control. Therefore, the project is highly relevant to the Small Business Innovation Research/ Small Business Technology Transfer program goals.
- The project addresses two key barriers to more widespread use in PV R&D and manufacturing: lack of image/scan data and slow speed and difficulty of taking measurements. If this project can lower these two barriers, it would allow for more ubiquitous use of QE/R

throughout the cell-module manufacturing stream, for uses including failure analysis, quality control, process control, process development and spanning efforts to improve/sustain quality, reliability, cost, and performance. Therefore, a successful project can have a high and broad impact across the program goals.

- The funding level required is adequate to build a prototype tool and test at end customer. In addition, the cost of equipment does not justify given the low value of the wafers, unlike the semiconductor market where the value of the wafer is much higher.
- The Solar Metrology, while important, is more of a “nice to have,” as the value of the wafer/cell is very low; hence, the manufacturers are unlikely to use it more widely. There is a small market for this.
- First generation does contact measurement (could reduce the yield).
- The applicability for fast process control is not clear. End-of-line (EOL) testing is weak but doable for process control, owing to the delay and complexity of forming an effective information feedback loop from the EOL to the process. The case for spectral binning is not well made (system design-for-spectrum applications).



**PROJECT: 9196**  
**BRITTMORE GROUP, LLC**

*Utility-Scale PV Cost Reduction  
 by Automated Panel Installation  
 System*



**FUNDING INFORMATION** \$0.70M | Small Business Innovation Research 2 | 12/2013–12/2015

## Project Description

To reduce the costs of installing large-scale solar projects, Brittmore Group, LLC is developing and demonstrating a robotics-based automated installation system. The system consists of three key components: a mobile factory where individual modules are preassembled and wired into larger panels; a simplified, fixed-tilt, ground-mount support system that doubles as an aboveground transport track for panel installation; and an industrial robot that takes preassembled panels from a centralized logistics area and installs them at megawatts-per-day rates. In this Small Business Innovation Research Phase 2 project, Brittmore Group will fully productize its system by taking all three components from alpha stage to full production. The anticipated public benefit of a fully productized Brittmore system is one of reduced large-scale photovoltaic installation costs and shorter time to power generation and revenue.

## Individual Reviewer Comments

- Brittmore Group seems to be on target with deliverables, and the company seems to fully think and vet its ideas for design, taking into account not only the speed of panel installation, but also the physical environment that the machines will be deployed, allowing for a long-term viability of the machines in use over time.
- The team is both producing the machine and owning the process for installation (they are their own end user).
- There is a potential of continual “innovation” and re-tweaking of robotics and not getting production capabilities out to market in a timely fashion.

## PROJECT: 9232 SPORIAN MICROSYSTEMS, INC.

*Advanced Ceramic Materials  
and Packaging Technologies  
for Realizing Sensors for  
Concentrating Solar Power  
Systems*



**FUNDING INFORMATION** \$1.0M | Small Business Innovation Research 2 | 01/2014–01/2016

### Project Description

Advancements in current instrumentation technology are needed to improve and optimize the performance and reliability of existing and future concentrating solar power (CSP) plants. A specific need has been identified for improved pressure, temperature, flow, and level sensors for emerging CSP heat transfer fluids (HTFs) and thermal energy storage fluids. Sporian Microsystems, Inc. is addressing this need by developing, testing, and demonstrating small, highly reliable, high-temperature-operable (600°C–1,300°C), corrosion-resistant sensors. Sporian's sensor technology is based on the combination of advanced high-temperature packaging, recently developed silicon carbide nitride (SiCN)-based polymer-derived ceramics, and advanced integrated electronics. The proposed sensors will improve the efficiency and economic viability of CSP systems, and may have a variety of additional applications for nuclear power generation, fossil fuel power generation, concentrating solar fuels, and transportation systems.

### Individual Reviewer Comments

- Although CSP plants currently operate without this innovation, the industry would benefit from a more accurate way to measure HTF flow rates. In addition, high-temperature HTF pressure instruments are presently very expensive. If a more economical solution were available, this would have a small but beneficial impact on the capital cost of CSP plants.

- There are presently no economical ways to continuously measure solar flux at or above 1,200 suns. As a result, the actual flux measurements are inferred from calculations with some uncertainty. A precise and low-cost flux monitor would enhance production efficiency by enabling more precise heliostat targeting and could prolong the life of receivers.
- A number of operational plants presently succeed in high-temperature control and monitoring without the benefit of the proposed invention. The cost of existing instrumentation compared to the total capital cost or the cost of instrumentation replacements compared to the total operation and maintenance budget is very small. While this innovative approach may yield alternative components with lower cost or higher sensitivity or reliability, it is unlikely that replacing existing instruments with the proposed design will materially reduce the levelized cost of energy (LCOE) of CSP plants.
- The authors have not shown how existing status quo solutions are inadequate to justify a change to their design or shown how their invention would achieve SunShot goals by reducing the LCOE of CSP plants. The proposal would have also been stronger with a discussion of how the invention would result in a durable high-temperature, high-intensity flux monitor, and it would have benefited from a discussion of costs for components the team has already sold or estimates for components to be developed.
- The project primarily focused on cost reduction in a currently available component and will have a limited impact.

## PROJECT: 9635 NEXT ENERGY TECHNOLOGIES, INC

### *Reliability Improvement in Solution Processable Roll-to-Roll Photovoltaic Modules*

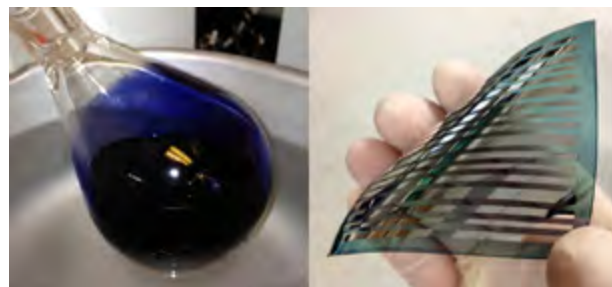

**FUNDING INFORMATION** \$1.0M | Small Business Innovation Research 2 | 05/2014–05/2016

## Project Description

Limitations of conventional solar technologies in their form factor, weight, flexibility, color-tunability, and transparency have impeded growth in flexible photovoltaic (PV) and large, building-integrated photovoltaic (BIPV) markets. Addressing this opportunity, Next Energy Technologies, Inc. is developing soluble small molecule organic semiconducting inks that can be coated onto conventional plastic rolls in high yields using roll-to-roll technology. The goal of this project is to demonstrate that the lifetime of encapsulated organic PV devices made using organic soluble small molecules is long enough to meet the needs of the markets (20–30 years for rigid encapsulation; 3–5 years for flexible encapsulation). The development of the technology is anticipated to achieve a price point that will compete with non-renewable energy sources and help the United States transition to a clean energy future.

## Individual Reviewer Comments

- The project appears to accurately track the state-of-the-art and addressable market segments for products that would benefit from this technology, along with their associated success criteria.
- Burn-in stability of PV layers show promise with respect to competitive benchmarks. In addition, progress on outlined Phase I technical deliverables appears to have been met.
- Low-cost flexible PV modules would be useful in applications where weight is a key factor, such as large-span commercial rooftops. The Standard Solar Model approach in principle is compatible with light weight and flexibility. This group presents I-V data showing excellent efficiency using this approach.
- The objective of this new project is to demonstrate long lifetime for encapsulated cells, using either rigid or flexible encapsulation. The goal of achieving a 20–30 year lifetime using rigid (glass) encapsulation seems to negate the benefit of this approach (light weight and flexibility). The goal of achieving a three to five year lifetime with flexible encapsulation seems more relevant. Unfortunately, the project goal for flexible encapsulation only requires light soaking, with no requirement for damp-heat testing, which is critically important for establishing whether this approach is viable. There is no indication that the I-V data shown has been independently verified. The devices to date appear to have been measured onsite in an inert atmosphere (glove box). Previous attempts to hermetically seal water-sensitive devices that are placed in an outdoor environment have been unsuccessful, and no information is provided to suggest that this team can solve this problem.
- Not enough detail was provided to ascertain what benefits the proposed technology has over existing/incumbent techniques. The assertion of semiconductor-polymer deficiencies is understood, but not the specific attributes of this solution-based technique.
- Lifetime targets cited for rigid and flexible encapsulations have not yet been demonstrated, and no pathway to do so is offered.
- Cost structure metrics of less than \$0.50 U.S. Dollar/watts-peak in 2015 and less than \$0.25 U.S. Dollar/watt-peak in 2019 are cited, but it is unclear how this 50% reduction will be achieved. The 2015 figure is at par with conventional technologies like crystalline silicon.

## PROJECT: 25814 NATIONAL RENEWABLE ENERGY LABORATORY

### Systems Analysis: Solar Manufacturing Cost Modeling and Analysis

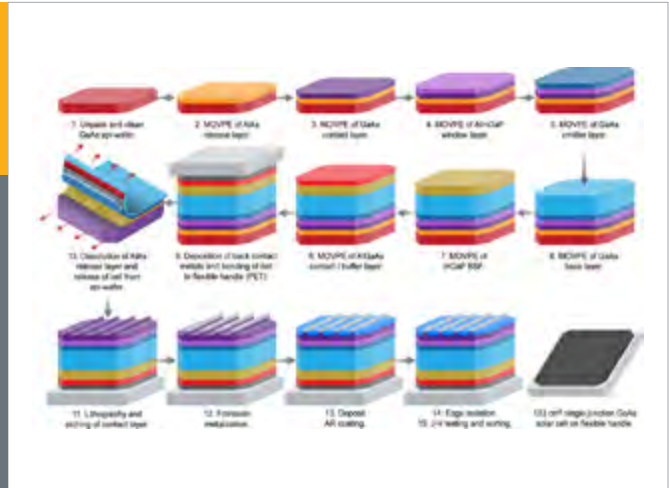

FUNDING INFORMATION \$1.0M | Supply Chain 2 | Ongoing

### Project Description

Because the SunShot Initiative aims to reduce solar prices dramatically, the Solar Energy Technologies Office (SETO) must understand the basis of these prices. Solar price analysis is complex, dynamic, and subject to numerous technological, market, and policy factors. Assessing solar system price drivers is especially complicated because of the complex tradeoffs among component costs and performance. The National Renewable Energy Laboratory’s (NREL’s) Solar Cost Modeling team has developed detailed and transparent bottom-up methods for analyzing solar costs and prices. The team uses these methods to give SETO and the solar industry the robust analysis they need to assess solar costs and prices.

### Individual Reviewer Comments

- The NREL cost modeling helps provide sanity and a reference point for all the solar-related programs (high leverage activity that can be used by different groups). The model evaluates most technologies from crystalline silicon to III-V materials and includes factory models. The outcomes inform the direction of photovoltaic (PV) research and development, high-quality and highly regarded work, and a broad spectrum of analyses (across vertical, horizontal, and technology platforms).
- The project approach is to develop analysis methods and conduct comparative analysis pertaining to a wide range of important cost/price questions/issues. The project is most relevant to the Liquid-phase deposition program goals and defines “best practice.”

- This work is a foundation for the industry’s growth. The geographic leveled cost of energy work is particularly impressive. This can be the basis for manufacturing resurgence in the United States as the calculations of some of the more advanced technologies progress. However, the project has a bit of a U.S.-centric view of the world.
- The rigorous approach/methodologies and publications to date have established the credibility of the team, stimulated improved analysis in the community, allowed for benchmark comparisons, and informed the community about opportunities and weaknesses in PV technology. As much as, if not more than, any other project, this project has shaped the direction of the national PV research and development direction.
- The project focuses on five analysis areas: (1) manufacturing cost/module-level cost roadmaps; (2) system installation costs/system-level cost roadmapping; (3) supply chain and rare materials analysis; (4) industry competitiveness; and (5) support of the SunShot portfolio of programs. The project has, and is likely to have, significant impact on the program goals.
- The project is funded at about \$3 million over 3 years. The funding level is appropriate and adequate to the project goals.
- The project team should look at return on invested capital as an additional metric for comparison/benchmarking.

## BALANCE OF SYSTEMS/ SOFT COSTS

SunShot works to support leaders at the local level to develop strategies and solutions to directly reduce the costs and barriers to solar access and deployment. Current efforts are building networks that can support the development and diffusion of proven and effective programs and help leaders establish clear pathways for sustainable and economical solar deployment across the United States and stakeholders to inform and receive feedback on PV integration.



August 14, 2014 - S-5! solar panel mounting clips used on the roof of RSF-A wing.

Photo credit: Dennis Schroeder / NREL

As overall solar prices have dropped, the United States has enjoyed unprecedented growth in both solar installations and jobs through the development of successful business and deployment models across the country. Between 2008 and 2012, the United States doubled renewable energy generation from wind, solar, and geothermal sources. Technology development, commer-

cialization, and manufacturing scaling have contributed significantly to rapid reductions in hardware costs since the inception of the SunShot Initiative. Now, however, addressing solar “Balance of System-Soft Costs (BOS-SC)” present the most substantial opportunities to spur strong U.S. growth in solar deployment in the coming years.

Figure 15: Total PV system price, by sector and system size (first half of 2012)

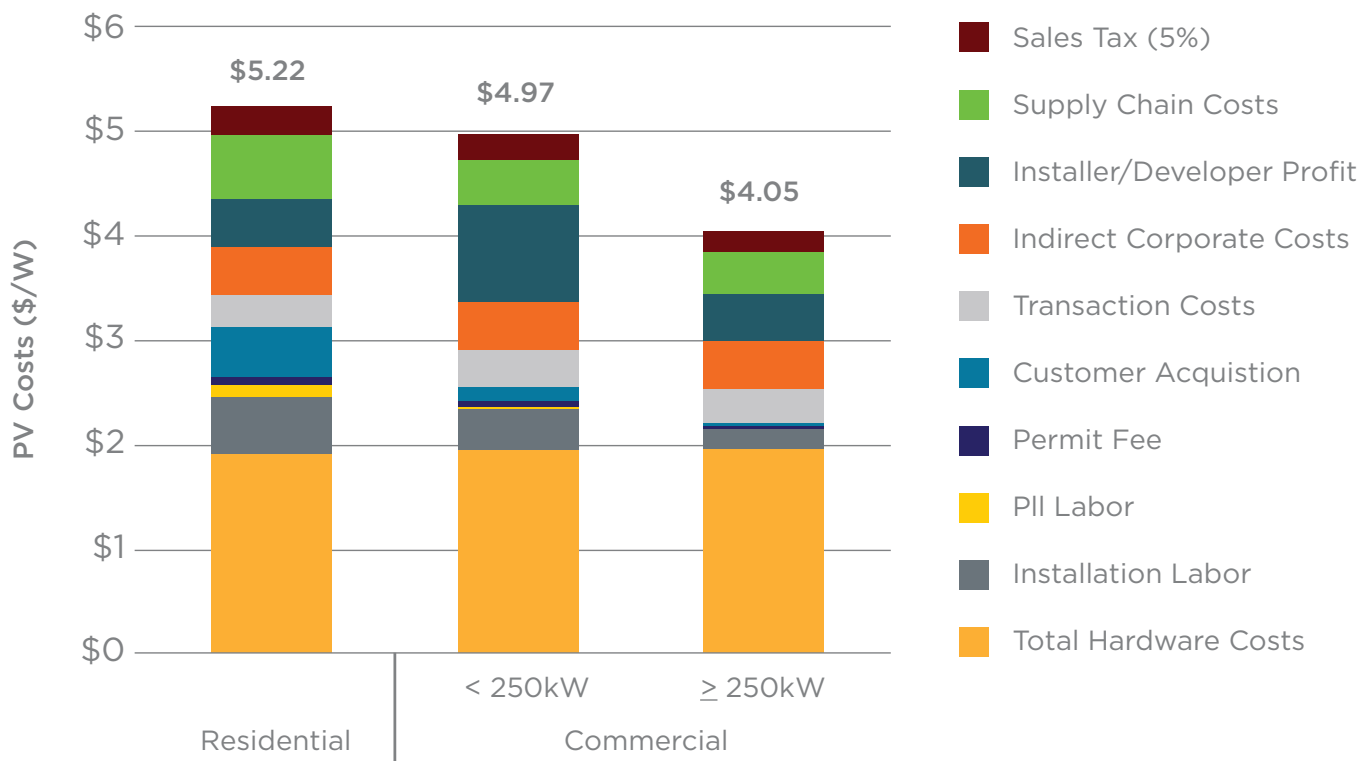

## BOS Overview

These soft costs include financing, customer acquisition, permitting, installation, labor, inspection, and other non-hardware costs. Taken together, soft costs and barriers to solar deployment now make up over half the cost of total system prices for residential, small, and large commercial photovoltaic (PV) systems. In order to achieve the goals of the SunShot Initiative, average soft costs need to be reduced to approximately \$0.65/W for residential systems and \$0.44/watt for commercial systems by 2020 (Figure 15).

Moreover, soft costs can vary significantly as a result of a fragmented energy market system that presents a highly variable landscape for those looking to deploy solar. The same solar equipment may vary widely in its final installation price due to process and market variations across jurisdictions. This creates barriers to even more rapid industry growth. Developing and adopting standards at the local level and applying regional approaches can

create a more uniform and accessible business environment. Through SunShot, the U.S. Department of Energy supports the development of innovative and scalable solutions, enabling communities and leaders to build their local economies and establish clean energy initiatives that meet their needs, while creating sustainable market conditions.

The SunShot Initiative has built a diverse portfolio of soft-cost activities. We are working with a broad range of stakeholders to expand access to solar energy to every home, business, and community. We are also supporting the development of an exciting new generation of powerful data, network, and

IT-related tools that amplify the effectiveness of these local initiatives and help grow markets intelligently. These tools increase market transparency, improve consumer protection, and improve access to low-cost financing for a growing number of consumers. Together, these efforts will make it faster, easier, and cheaper than ever before to deploy solar technology.

In order to support reductions in soft costs and promote uniform access to solar, the SunShot BOS program has focused its efforts into the following activity areas:

- Empowering state and local decision-makers through timely and actionable resources, peer networks, and technical assistance
- Harnessing big data analysis and technical solutions to support the many stakeholders involved in solar deployment
- Training an innovative solar workforce to enable the solar industry to meet growing demand
- Developing solar finance and business solutions to expand access to capital and accelerate market growth.

Underlying these efforts are extensive analyses that characterize non-hardware costs and barriers. Work from the national laboratories including NREL, Sandia National Laboratories, Lawrence Berkeley National Laboratory, and Argonne National Laboratory, as well as insightful tools and analyses from project partners, like the Rocky Mountain Institute and Optony, Inc., have helped shed light on these costs and the potential pathways to address them. These programs have developed datasets, standards, and guides that can serve consumers across the country.

## Empowering State and Local Leaders

SunShot works to support leaders that develop strategies and solutions to directly reduce the costs and barriers to solar access as well as strategies to avoid barriers that may slow deployment at the local level. Our programs are structured to measure the effectiveness of a variety of these local programs and strategies. Through the Rooftop Solar Challenge (RSC 1 and 2), SunShot has benchmarked hundreds of communities and empowered them to advance their solar market maturity through measures that have saved Americans nearly 800 years of “red tape” related roadblocks to date. These projects have shortened permitting and inspection times by 40% and reduced permitting fees by 12% for participants. Innovations developed through RSC 1 communities in 2013 are now being shared through training and technical assistance from SunShot’s Solar Outreach Partnership (SolarOPs) program.

In April 2014, SunShot launched a new program called Solar Market Pathways to support the development of sustainable, multiyear solar deployment plans. We anticipate that this program will enable new activity to support community efforts like shared solar, financing programs like commercial property assessed clean energy, and the incorporation of solar into local emergency response plans. The goal of Solar Market Pathways is to help provide local business certainty, address regulatory challenges, disseminate best practices and lessons learned, and establish a clear path for the next 5–10 years of solar deployment in the awarded region.

Building networks that can support the development and diffusion of proven and effective programs for solar deployment continues to be a core strategy we employ for expanding access to solar energy.

## Harnessing Big Data Analysis and Technical Solutions

At the most fundamental level, soft costs are the result of the time and effort people spend to accomplish tasks related to solar deployment. Automation, increased access to data and information, and software and information management tools can help reduce the time and effort needed to complete a solar installation. SunShot is supporting the creation, analysis, and functionalization of data and information through a number of efforts.

By combining the power of big data with cutting-edge social science, projects funded under SunShot’s Solar Energy Evolution and Diffusion Studies (SEEDS) program enable researchers to test, measure, and validate local deployment program effectiveness—accelerating innovation in business and market development while advancing foundational knowledge of social science dynamics. In addition, soft-costs-related Incubator awards support small businesses and startups that provide solutions to soft-cost challenges for a variety of stakeholders, including installers, finance providers, state and local jurisdictions, and the public. Through these efforts—along with a variety of solutions developed by our partners, including national laboratories, non-profit organizations, and others—a wide range of tools are now available to support solar deployment.

## Training a Strong Solar Workforce

As the solar industry has grown, SunShot has focused its efforts on the creation of consistent, high-quality workforce training and skills credentialing in the solar industry and beyond. The Solar Instructor Training Network (SITN) is a nationwide network of qualified solar instructors who train solar installers, technicians, designers, and sales professionals in every region of the United States through partnerships with nearly 400 community colleges. Building on this effort, SITN has also helped provide high-quality training resources to building code officials and local inspectors, helped ensure that consumers receive optimal production and safety from PV installations, and increased consumer confidence.

In addition, the Grid Engineering for Accelerated Renewable Energy Deployment (GEARED) program has created a network of four regional university training consortia that connect utilities and solar manufacturers with university power system engineering programs to train current and future engineers. These new engineers will be able to integrate renewable energy into the grid and transform the electric utility sector into a marketplace that supports innovation. Solar design and grid integration at the utility scale is getting a jumpstart through another award to the National Rural Electric Cooperative Association (NRECA). NRECA will help its co-ops build solar management expertise locally and create replicable models for deploying solar through its more than 900-member electric cooperatives.

## Developing Solar Finance and Business Solutions

Solar installers and utility professionals aren't the only professionals who need solar skills. SunShot also supports work in finance, real estate, and community and shared solar development. Our national laboratories, universities, nonprofits, and talented startups have led exciting workshops, gathered stakeholders for work sessions, and built a suite of new tools to support solar growth. Our Solar Access to Public Capital (SAPC) group is working with financial institutions, project developers, and manufacturers to publicly release standardized contracts and methods for assessing risk portfolios in order to unlock new streams of capital to support solar project finance.

Finally, DOE offers the SunShot Prize, which awards \$10 million to companies who are able to install solar PV on at least 6,000 rooftops, while meeting targeted SunShot goals.

Looking forward, the SunShot BOS program aims to expand the availability of high-quality data, information, tools, and resources to support the solar industry. We continue to provide opportunities for state and local leaders to tap into networks that can help them sustainably and economically deploy solar. We are increasing support for the testing, measuring, and analysis needed to ensure that communities (both local and professional) can design programs that work for them and the people they serve. We look forward to expanding access to solar energy and helping to make it faster, cheaper, and easier for all Americans to realize the many benefits of solar energy today and into the future.



**Dr. Elaine Ulrich**

*Balance of Systems,  
Soft Costs Program Manager*  
Solar Energy  
Technologies Office  
U.S. Department of Energy

### Team Members

Monica Andrews, SETA  
David Arfin, Consultant  
Daniel Boff, SETA  
Anna Brockway, SunShot Fellow  
Adam Cohen, AAAS Fellow  
Michael Contreras, AAAS Fellow  
Rose Marie Holsing, Technical Project Officer  
Joshua Huneycutt, Technology Manager  
Kelly Knutsen, Technology Manager  
Olayinka Kolawole, Technology Manager  
Christina Nichols, SETA  
Ammar Qusaibaty, SETA



## BOS Portfolio Review Average, Range, and Standard Deviation

Of the 251 projects in the SunShot Portfolio, 45 projects were reviewed as part of the Balance of System (BOS) portfolio review. Each reviewed project is listed in Table 12. Projects were ranked on a 1–5 scale, with “1” being the lowest possible score for a category and “5” being the highest score. Reviewers provided overall ratings on each project’s relevance to the SunShot Initiative and BOS portfolio mission and goals, overall impact, level of funding, and approach taken.

For the BOS portfolio, the overall average rating for a project was 3.72. Of the 45 projects, 24 were performing above the mean, while 21 achieved scores that were lower than the 3.72 average. The range of overall scores was 2.04, with a median of 3.75, mode of 4.00, and standard deviation of 0.47. This information is presented in Table 11 and Figure 16. Overall, the data have a skewness of  $-.18$  and are skewed to the left, as the mean is slightly smaller than the median, and median is smaller than the mode. The reviewers’ comments on the program as a whole are provided in the following sections.

Table 11: BOS Portfolio Review Average, Range, and Standard Deviation

	Average	Range	Standard Deviation
Relevance	4.20	2.67	0.59
Impact	3.69	2.33	0.57
Funding	3.21	2.33	0.51
Approach	3.80	2.33	0.62
Overall	3.72	2.58	0.47

Figure 16: Frequency of overall project rating for BOS portfolio

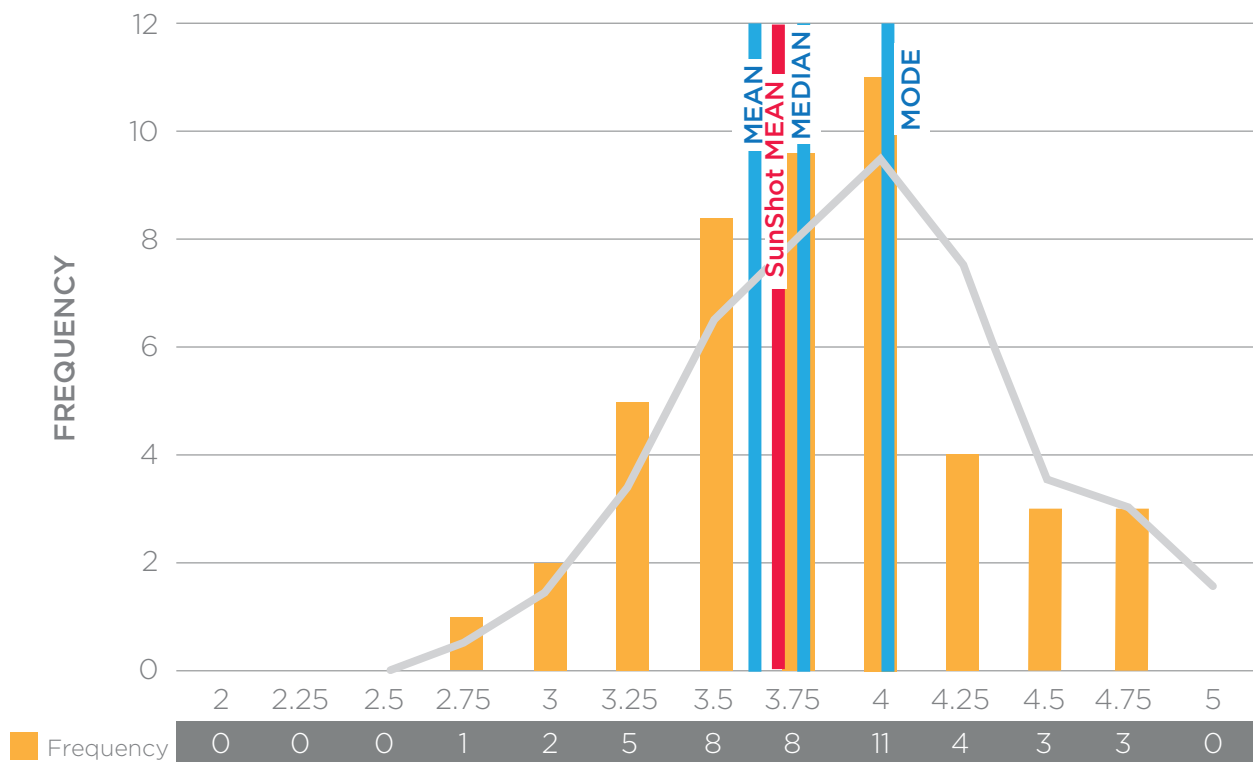

## BOS Portfolio Reviewer Report

The following section contains the evaluation of the BOS portfolio, as analyzed by the reviewers assigned to the BOS Portfolio. To preserve the integrity of the reviewer's responses, the analysis is provided almost verbatim, with minor edits for grammar.

### Quality and Impact of the Portfolio

The overall BOS portfolio is large with respect to the number of projects and has the potential to reduce soft costs. For example, the collaborations with the academic institutions are a real strength to the portfolio as it engages a broad group of people and is expanding the scope of the work. More of this work should be shared with other stakeholders such as permittees and policy makers. Some of the projects are also actively engaging the industry itself, which further adds to the strength of the project portfolio and SunShot Initiative.

The most promising projects in the portfolio are those which are (1) focused on pilot studies of real world situations or programs, (2) projects and initiatives that include market education and training offer great promise in educating the market, and (3) projects that focus on customer acquisition and market research efforts are effective in addressing the portfolio goals.

However, the portfolio appeared to cover a lot of topic areas with seemingly different objectives and goals. In other cases, such as SEEDs and GEARED, it was unclear as to what the overall strategy even was for those sets of projects. Permitting tools as a whole were also not networked, clearly integrated, or streamlined. DOE should consider developing strategies for streamlining tracks and objectives. DOE should also consider concentrating funding across a smaller number of projects to provide greater strategic oversight, benchmarking, and evaluation.

Moreover, the awardees did not appear to have a clear picture or justification for how their project or funding will reduce or alleviate soft costs, what percent of the market is addressed by their work, or the "pain points" that affect consumer decisions. Some reviewers ques-

tioned whether it would have been more effective to concentrate funding across a lesser number of projects and provide greater strategic oversight and evaluation to the project performers, but the review panel did not offer a strong opinion in this regard.

### Appropriateness of Funding Relative to Program Goals

There is insufficient information provided to fully address the appropriateness of the funding to the BOS portfolio, as more detailed information on budget history, subgroup strategies, and objectives was deemed critical in order to make a truly fair analysis. It was determined, however, that funding should be focused on the soft costs identified in the Soft Costs Monitoring Reports. In addition, some soft costs project funding should be focused on market issues, such as interconnectedness or financing as those areas seemed under-represented.

It is also important to note that the overall portfolio funding may be over allocated to national laboratories and under allocated other market entities and players. In particular, there is significant overhead and costs associated with the laboratory projects and concern regarding this imbalance and whether there was an appropriate return on investment. Another example would be that of the National Renewable Energy Laboratory (NREL), whose technical assistance projects may be providing too much technical assistance to each requesting party, which was referenced as averaging 80 hours per support.

### Future Direction and Composition of Portfolio

Given that the portfolio as very diverse, strategies need to be developed to streamline with tracks or objectives to ensure consistency across the BOS portfolio. A clear programmatic strategy for how solar soft costs can be reduced could include lowering the costs for utilities or requiring cost share by focusing on after sales and financing, net metering, business models, and tools to map the impact of solar on distribution feeders.

Projects that provide funding to utilities need to include some elements of joint governance and should focus on partnerships and broadening the engagements, in particular with education and information. Discussions and engagement around the “Utility of the Future” and high saturation market penetration need to happen and market barriers to wide-spread development and deployment must be addressed. In addition, DOE should separate policy and demand side work from soft costs in order to determine their effectiveness independent of BOS.

A need for greater and improved benchmarking efforts and specifying outcomes is also present. Each subarea

needs to a process to allow groups to coordinate and align in strategy and cross pollination. It would be good to:

- Incorporate a section on transmission and then disseminate NREL’s study on 80% renewables
- Provide more education and outreach across market sectors
- Focus on segment-specific projects such as those focused on women or retirees and demand generation
- Conduct research and development on net metering
- Have projects that determine how to sell solar into capacity markets
- Hold workshops for stakeholders to engage in solar.

**Table 12: Projects Reviewed under Balance of Systems/Soft Costs Program**

Award Number	Project Name	Project Organization
3525	Solar Outreach Partnership	ICLEI - Local Governments for Sustainability
3526	Solar Outreach Partnership	International City/County Management Association
4137	National Administrator of the SITN	Interstate Renewable Energy Council
5349	National Solar Permitting Database	Clean Power Finance
5350	National Database of Utility Rates	Illinois State University
5351	PVMapper Utility-Scale Siting Tool	Boise State University
5352	Regulatory and Utility Solutions to Advance SunShot Initiative Goals	Interstate Renewable Energy Council
5353	Innovative Solar Business Modeling	Rocky Mountain Institute
5354	Hawaii's Clean Energy Transformation and Grid Connection	Hawaii Department of Business
6128	The Influence of Novel Behavioral Strategies in Promoting the Diffusion of Solar Energy	Yale University
6129	Toward an Emergent Model of Technology Adoption for Accelerating the Diffusion of Residential Solar PV	University of Texas at Austin
6130	Helios: Understanding Solar Evolution through Text Analytics	SRI International
6131	Evaluating the Causes of Photovoltaics Cost Reduction: Why Is PV Different?	Massachusetts Institute of Technology
6133	Forecasting and Influencing Technological Progress in Solar Energy	University of North Carolina at Charlotte
6305	New England Solar Cost-Reduction Partnership	Clean Energy States Alliance

Table 12: Projects Reviewed under Balance of Systems/Soft Costs Program

Award Number	Project Name	Project Organization
6306	NYSolar Smart	City University of New York
6307	Pacific Northwest Solar Partnership	Washington State Department of Commerce
6308	American Solar Transformation Initiative	Optony Inc.
6309	Go SOLAR Florida	Broward County, Florida
6310	Solar Ready II	Mid-America Regional Council
6312	Golden State Solar Impact	California Center for Sustainable Energy
6327	Leveraging Industry Research to Educate a Future Electric Grid Workforce	Electric Power Research Institute, Inc.
6333	Solar Utility Network Deployment Acceleration	National Rural Electric Cooperative Association
6339	Southwest United States of America - Distributed Technology Training Consortia (SWUSA)	Electricore, Inc.
6340	FEEDER: Foundations for Engineering Education for Distributed Energy Resources	University of Central Florida
6341	MARMET: MidAmerica Regional Microgrid Education and Training Consortium	Missouri University of Science and Technology
6342	National Network Administrator of GEARED	Interstate Renewable Energy Council
25694	Soft-Cost Modeling and Analysis	National Renewable Energy Laboratory
25695	Advanced Financing Mechanisms to Achieve SunShot	National Renewable Energy Laboratory
25696	Policy Stacking and Foundational Analysis	National Renewable Energy Laboratory
25698	Residential and Commercial Real Estate and PV Energy Systems	Sandia National Laboratories
25699	Reducing Project Risk through Analysis of Solar PV Reliability Data	Sandia National Laboratories
25700	Solar Loads and Roofing Structures: When Is Additional Engineering Needed?	Sandia National Laboratories
25701	Solar Glare Hazard Analysis and Siting Tool	Sandia National Laboratories
25702	Solar Technical Assistance Team	National Renewable Energy Laboratory
25703	Soft-Cost Modeling and Analysis	Lawrence Berkeley National Laboratory
25704	Policy Stacking and Foundational Analysis	Lawrence Berkeley National Laboratory
25705	Residential and Commercial Real Estate and PV Energy Systems	Lawrence Berkeley National Laboratory
26153	Design of Social and Economic Incentives and Information Campaigns to Promote Solar Technology Diffusion through Data-Driven Behavior Modeling	Sandia National Laboratories
26154	Understanding the Evolution of Customer Motivations and Adoption Barriers in Residential Photovoltaics Markets	National Renewable Energy Laboratory
27329	Long-Term Monitoring of Utility-Scale Solar Energy Development and Application of Remote Sensing Technologies	Argonne National Laboratory
27690	Water Use by PV Supply Chain	National Renewable Energy Laboratory
27816	Regulatory and Permitting Information Desktop (RAPID) Roadmap	National Renewable Energy Laboratory

## 3525 ICLEI - LOCAL GOVERNMENTS FOR SUSTAINABILITY

*Solar Outreach Partnership*



**FUNDING INFORMATION** \$5.1M | SolarOPs | 08/2010–07/2015

### Project Description

The SunShot Solar Outreach Partnership (SolarOPs) Program is empowering local governments to go solar. Composed of experts in solar soft-cost reduction strategies, the team collects, creates, and delivers best practices to accelerate solar energy adoption by providing timely and actionable information to local governments across the country. Through regional workshops and e-learning activities, the SolarOPs team has reached more than 4,000 individuals in all 50 states, representing more than 1,500 local government entities.

One of the key features of SolarOPs is the delivery of targeted one-on-one technical assistance to local governments looking to make their communities solar ready. Technical assistance is being delivered to local governments in North Carolina, California, Delaware, and New Jersey, among others.

The SolarOPs team is developing fact sheets, case studies, and technical reports based on cutting-edge research related to solar and economic development, solar and resiliency planning, innovative solar financing, solar jobs analysis, community solar, and solar and firefighter safety. In addition, the SolarOPs team coordinates communications among the Rooftop Solar Challenge II teams whose work covers 28 states and Washington, D.C., representing nearly 150 million people. For more information, visit [solaroutreach.org](http://solaroutreach.org).

### Individual Reviewer Comments

- Delivering one-on-one support is very ambitious, but valuable. However, it is unclear how the project will be sustained, or which resources are frequently requested and how they might be better utilized.
- ICLEI meets a clear market need by providing technical assistance to local governments. The team clearly

communicates to avoid redundancies with the Rooftop Solar initiatives in an effort to reduce redundancies across U.S. Department of Energy contracts. When awarding to the grantees, it is recommended to develop market maps to understand how the portfolio overall is either redundant or complementary in its initiatives. While this effort is doing a good job reducing redundancies, attention to this issue at the award/portfolio level may create efficiencies at the contract level—reducing the burden placed on grantees to accommodate one another.

- This project aims to provide technical support to local jurisdictions across the country. There is clearly a need for technical support for municipalities that are new to solar, or that are in states without a strong statewide or regional capacity to provide such support. The team has a strong target audience and good organizational partners; however, no cost sharing was identified.
- This is a great model to do 20-minute personalized consultations at professional conferences. The team should catalogue these requests and the information provided. It is a good strategy to work with the planning association.
- Given the vast need for technical support across the country, it will probably be most productive for ICLEI to focus its resources in states that lack a source of technical support. The summary paper states that ICLEI provides a communications coordination function among the Rooftop Solar Challenge II teams. The presentation time did not allow enough time to really discuss this aspect of their work, but that function could be very important.

- It is unclear what specific information is being shared on soft-cost reduction strategies and how those compare to the other groups working on this issue.
- The number of participants, and the number of megawatts installed seems low. Other metrics could be provided to show engagement with local governments. It would be good to know what the statistics are that are related to each of their deliverables. For example, it would be helpful to know how many one-on-one technical assistance opportunities there were, how many fact sheets were developed and delivered, how many case studies were developed and delivered, and how many technical reports were developed and delivered, etc.
- The team has created a lot of outputs (185 technical resources created), but shown no evidence of impact to date (they are beginning to interview audience for signs of impact). It is, therefore, not clear how effective ICLEI has been through this initiative. There are no metrics; although, they plan to collect some performance data in the coming year. ICLEI receives a higher level of funding than many of the other projects, but has so far only reached 4,000 individuals and 1,500 local governments.
- Examples of the type of assistance that is helping with one-on-one project facilitation would be helpful. It would also be helpful to know what the team is offering that is not available from industry or other stakeholders.
- Tools to create municipal pooled financing and specific barriers and strategies related to the Program to Advance Cell Efficiency could be called out in more depth or included if not in plan.
- They do not have any in-house staff expertise and farm out all the expertise to other organizations, and this is problematic given the high level of funding that they get, as well as because it means that the organization is not building its own competency on the issues. It seems redundant that this group and the county group both farm out the assistance requests to other organizations.

## PROJECT: 3526 INTERNATIONAL CITY/COUNTY MANAGEMENT ASSOCIATION

*Solar Outreach Partnership*

# SOLAR OUTREACH

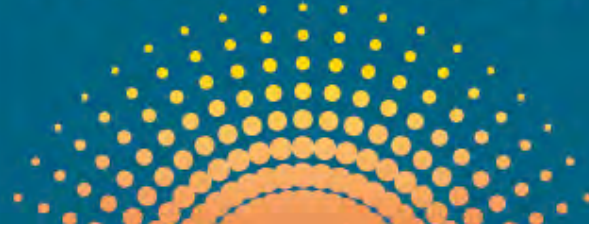

**FUNDING INFORMATION** \$4.9M | SolarOPs | 08/2010–07/2015

### Project Description

The SunShot Solar Outreach Partnership (SolarOPs) Program is empowering local governments to go solar. Composed of experts in solar soft-cost reduction strategies, the team collects, creates, and delivers best practices to accelerate solar energy adoption by providing timely and actionable information to local governments across the country. Through regional workshops and e-learning activities, the SolarOPs team has reached more than 4,000 individuals in all 50 states, representing more than 1,500 local government entities.

One of the key features of SolarOPs is the delivery of targeted one-on-one technical assistance to local governments looking to make their communities solar ready. Technical assistance is being delivered to local governments in North Carolina, California, Delaware, and New Jersey, among others.

The SolarOPs team is developing fact sheets, case studies, and technical reports based on cutting-edge research related to solar and economic development, solar and resiliency planning, innovative solar financing, solar jobs analysis, community solar, and solar and firefighter safety. In addition, the SolarOPs team coordinates communications among the Rooftop Solar Challenge II teams whose work covers 28 states and Washington, D.C., representing nearly 150 million people. For more information, visit [solaroutreach.org](http://solaroutreach.org).

### Individual Reviewer Comments

- The project meets a clear market need by providing outreach, education, and support to local governments who might not otherwise be served by the Rooftop Solar Challenges. It could use more money for this large-scale undertaking that could be scaled to other regions,

if successful. They need funding of staff time to talk with others working on this issue to standardize their recommendations.

- A strength of this award is the team, which includes the International City/County Management Association (ICMA), the National Association of Regional Councils, and the American Planning Association. Utilizing these membership organizations for the dissemination of publications, outreach, workshops, training videos, webinars, podcasts, and “ask an expert” tools have reached 8,000 individuals, representing more than 1,200 local governments. In addition, the combination of in-person and permanent training resources is another strength.
- An additional strength of the project is the data provided, which indicate widespread dissemination of resources. For both solar outreach partnerships, the span of outreach is impressive, but more emphasis, documentation, and goals about outcomes of direct solar deployment by municipalities would be helpful.
- ICMA does a good job in working through established networks of planners, city managers, and other local leaders. The association is utilizing creative techniques, including online learning communities and peer groups.
- The project involves strategies targeted to overcome key barriers, new opportunities, and gaps that municipalities can fill more readily than other market actors.
- To date, the project has reached 8,000 individuals in 50 states, but it is hard to assess if this is a good or a weak outcome given the large budget for this initiative.

Surveys have not been conducted to find out if balance-of-system soft costs have been reduced as a result of this award. Another weakness is that there is no cost sharing on this project.

- This initiative might be stronger if it links the local governments it serves to the other technical support resources that are funded through SunShot (including the policy research and the state/regional-level consortia). Both ICMA and its companion organization ICLEI skip over national, state, and regional entities and work directly with local-level leaders.
- A comment to the U.S. Department of Energy: Grantees should be given clear performance metrics to support their funding, in particular those that have education- and information-driven efforts where the output and outcomes are less tangible. Lessons can be taken from educational and informational programs in energy efficiency that have made strides in performance monitoring and impact assessments for similar initiatives.
- It is still unclear what training is being used and which metrics are utilized to ensure that training resources have an impact.



## PROJECT: 4137 INTERSTATE RENEWABLE ENERGY COUNCIL

*National Administrator  
of the SITN*

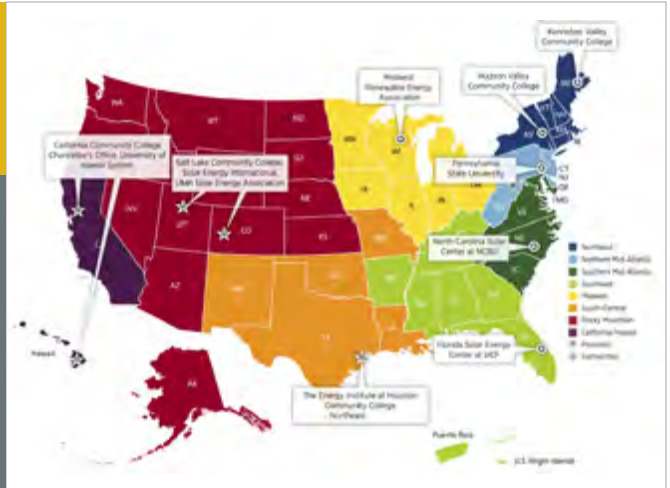

**FUNDING INFORMATION** \$4.9M | Solar Instructor Training Network | 10/2010–12/2015

### Project Description

The Interstate Renewable Energy Council (IREC) serves as the national point of contact for the network, conducting outreach to disseminate its products and best practices. IREC has led the development of a robust national infrastructure that can meet the employment needs of a rapidly growing domestic solar industry. The group manages the network's collaboration, coordinates joint activities, and works with a broad set of stakeholders to prioritize and address issues related to solar workforce training. IREC assesses instructional quality by credentialing programs and led the formation of the North America Board of Certified Energy Practitioners.

### Individual Reviewer Comments

- This workforce initiative at scale has the potential to be highly impactful. The project targets an important but often ignored piece of the market (e.g., trainers). In addition, the goal of standardizing solar instructor and training efforts is vitally important to workforce quality.
- The team has worked with more than 1,000 instructors and 450 community colleges and training organizations. The effort provides hands-on training as a core part of the framework. The group helped develop consistency in trainings nationally with respect to both the skill sets being taught and the methods for training. The team is also working to unify regional standards.
- A strength of this award is the national administrator's ability to facilitate synergistic relationships among the regional training providers. The national administrator can help the Regional Training Providers to utilize best practices and eliminate duplication of effort.
- Another strength of this award is the administrator's role as a national point of contact for the solar instructor training network. The national administrator's award will help achieve the goals of providing accessible, high-quality, market-valued solar training.
- Weaknesses of this award include having no plan for workforce assessment/evaluation of potential impacts and providing no discussion of how standardization will interface with local regulation, codes, zoning standards, and permitting in the training process.
- The project indirectly attacks the problem of soft costs, but does so with two key stakeholders (authorities having jurisdiction and direct workforce). The project team needs to demonstrate what the impact for workforce has been (e.g., company testimonies).
- A possible weakness of this award is a lack of cost share by the awardee.
- It is unclear what the day-to-day tasks really are and what is really being coordinated to justify the funding expenditure. In addition, it is unclear how to measure the success of this project.

## PROJECT: 5349 CLEAN POWER FINANCE

### *National Solar Permitting Database*



**FUNDING INFORMATION** \$3.0M | Soft BOS | 09/2011–08/2014

### Project Description

This database is designed to help streamline and reduce the time and costs attributed to the solar permitting process. The community-based online tool compiles the most complete and accurate permitting requirements from solar professionals and local authorities in one single online location.

### Individual Reviewer Comments

- The project tackles permitting nationally, aims to be self-sustaining, and has continued contribution levels, as well as the ability to change permitting regimens as opposed to just being informational. This national database is an open tool for the industry that is compelling for permitting and access to information. It is actively used by existing solar groups, such as VoteSolar, and has the greatest potential for commercial viability among permitting databases.
- The objective of identifying and providing a database of permitting requirements is important and consistent with the program goals. To make best use of this resource, Clean Power Finance should continue to work with the regional and state-specific projects that are implementing permitting strategies and tools. The regional and state-based initiatives may be able to use the national information to support advocacy efforts to achieve approval for their permitting proposals.
- Given the national scope of the database, the total of 400 registered users seemed low, but that number is expected to grow. There is value of having a national database for the purpose of analyzing differences in permitting approaches across jurisdictions and regions, but now that this tool is in place and will be maintained for another five years, future federal dollars may be better spent in supporting additional regional or state permitting initiatives.
- Key concerns include the following: quality assurance on the materials edited and posted for accuracy, strategies for continued relevance to the market (updates, usability, accuracy of information), and plans for commercialization post award. In addition, the U.S. Department of Energy should consider the value of such aggregated, national versus regional or local tools currently under development with other awardees. There appears to be opportunities to streamline these activities and their funding support in the grantee review process.
- There is some additional concern over whether the tool will continue to be actively used without active management and recruitment, as well as concerns regarding the verification of process information.
- The project is somewhat passive in implementing permitting changes in local regimes; although, information can be used by local advocates.

## PROJECT: 5350 ILLINOIS STATE UNIVERSITY

### *National Database of Utility Rates*

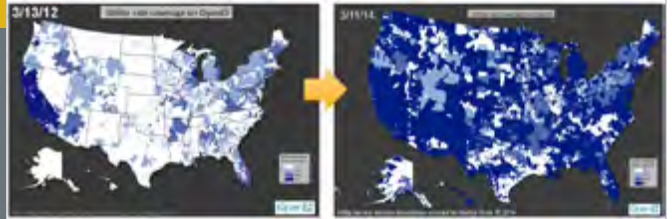

**FUNDING INFORMATION** \$0.85M | Soft BOS | 09/2011–08/2014

## Project Description

The National Renewable Energy Laboratory created the National Utility Rate Database in 2010 as a free, Web-based tool in which the energy analysis community could contribute, edit, and download utility rate data. Illinois State University was selected to populate, maintain, and improve the database.

## Individual Reviewer Comments

- This will be a very helpful database for a variety of topics. The database includes all riders, which is helpful to all types of clean energy efforts.
- The strength of this project is that if kept up to date, it will provide useful information to homeowners and developers who want to understand some of the economic benefits of investing in a solar system.
- The weakness of this project is that the information in the database will be very difficult to maintain, as rates are always changing. Thought should be given to partnering with or seeking support from the National Association of Regulatory Utility Commissioners and Edison Electric Institute (which could serve as an intermediary with investor-owned utilities). Another option may be to create a tool or handbook for project developers to use to enable them to efficiently find rates for specific projects, as an alternative to providing the actual rates.
- Given the resources expended in developing and maintaining this database, it seems like the information should be made available beyond solar applications and audiences. Consumer advocates, energy efficiency program representatives, and state regulators might all be able to make use of this database, which could help justify the cost of developing and maintaining it.
- Utility rates are critical to understanding customer economics. Access at the national level should not mask important elements, such as time of use and demand charges that might not get full treatment in this approach.
- It is important to consider how evolution of net metering tariffs will be reflected and how updates will be maintained. It is unclear whether a template approach rather than maintaining an ongoing database has been considered or is even a possibility.
- For this to be useful, the database must be institutionalized for continuous updating, so the U.S. Department of Energy should encourage a long-term management plan. Perhaps there are ways of engaging the U.S. Energy Information Administration to take up this charge in the long term.
- Given that this project seems to mainly benefit solar developers in reducing their marketing strategy staff, the team should consider doing this as a cost share with industry.

**PROJECT: 5351 BOISE STATE UNIVERSITY**

*PVMapper Utility-Scale Siting Tool*



**FUNDING INFORMATION** \$2.8M | Soft BOS | 09/2011–08/2014

## Project Description

This project created an open-source project-planning tool based on geographic information systems that optimizes siting for utility-scale solar developments. The tool enables users to assess sites based on quantifiable physical characteristics and constraints of the natural resource, as well as military, land use, solar resource, water resource, and public acceptance factors.

## Individual Reviewer Comments

- The tool-based deliverable has garnered industry stakeholder support and feedback. The customizability of the tool is a strong plus to ensure relevance of the tool. Hopefully the tool will be adapted and commercialized by private vendors so this resource will continue beyond this project.
- This tool offers a number of compelling and much-needed data layers for siting, most notably the social and public preference analysis of sites. In addition, this tool can deliver customized output for different project scales and sizes.
- While this tool will likely prove useful in streamlining the siting process, the commercialization plan is weak. This is not unique to this project; SunShot should seriously consider including a commercialization component and exit strategy requirement of all grantees to support the continued use and viability of the market assets it is creating in its portfolio.

- The budget for this effort is significant and could likely be reduced by one-quarter while retaining its core mission and goals.
- The materials identify three successful applications—it will be important to conduct additional measurement and evaluation of the transferability of the tool.
- The tool’s innovative method of using survey data and geospatial mapping is very interesting. One question remaining is whether there are limitations on the effectiveness of using survey results from different regions of the country to predict possible public acceptance of projects in different regions. It is also unclear what magnitude of savings this project will bring to the industry and what metrics will be used to measure the project’s impact and success.
- It is unclear how the mapping tool will continue to be updated with data sources after this program ends. In addition, the system design tool seems to be a little less valuable, but they could still help.

## PROJECT: 5352 INTERSTATE RENEWABLE ENERGY COUNCIL

*Regulatory and Utility Solutions to Advance SunShot Initiative Goals*



**FUNDING INFORMATION** \$3.0M | Soft BOS | 09/2011–08/2014

### Project Description

The Interstate Renewable Energy Council (IREC) and its sub-partners—Keyes, Fox & Wiedman, and others—will work to dramatically expand market opportunities for solar photovoltaic (PV) by pursuing fair and transparent solar pricing and interconnection policies (for all parties—utilities, solar developers, and consumers) in the 20 states with the highest potential for significant solar PV market growth. IREC will work to analyze and suggest collaborative remedies (for debate by all stakeholders) to the technical and administrative barriers still impacting cost-effective interconnection and transmission in the 10 states poised to achieve the highest penetrations of solar PV. This award will support IREC in encouraging technical and policy studies that drive solutions to the incorporation of high-penetration solar PV scenarios into utility planning and operations management activities in the five states with the highest solar PV penetrations. IREC will also provide technical assistance to communities and states that wish to explore community and shared solar models.

### Individual Reviewer Comments

- IREC is focusing on five critical policy and regulatory areas and appears to have focused its work on key states where it could have significant impact. By engaging in net metering and storage regulatory proceedings, IREC is providing valuable information to decision makers. It is therefore critical to have sources of independent analysis like the work IREC is doing for state regulatory proceedings.
- The project has excellent resources. The expansion from net metering to evaluating the benefits to the grid is a helpful one. The focus is on the potential for net metering modifications to meet challenges of higher saturation, including equity concerns.
- A strength of this proposal is that IREC appears to be partnering with some of the other initiatives, particularly the state efforts in Hawaii and New England. To the extent IREC can share its expertise with state and regional initiatives, it can preclude the need for each state or region to reinvent the wheel in areas such as interconnection standards and net-metering models.
- Transmission, storage, and interconnection working groups are the Independent System Operator's (ISO's) high priority. Depending on the outcome of the Western transmission work, there could be potential to extend the approach to recovery time objectives in the East and Midwest.
- The project has a proven high value on community solar, net metering, and interconnection.
- There is concern of funding running out when the value of solar conversations heat up, so it would be good to refund them. No cost share is leveraged for this project.
- It would be good to have the team reach out to other groups to build consensus on this issue, so not just IREC's position is included.

## PROJECT: 5353 ROCKY MOUNTAIN INSTITUTE

### *Innovative Solar Business Modeling*

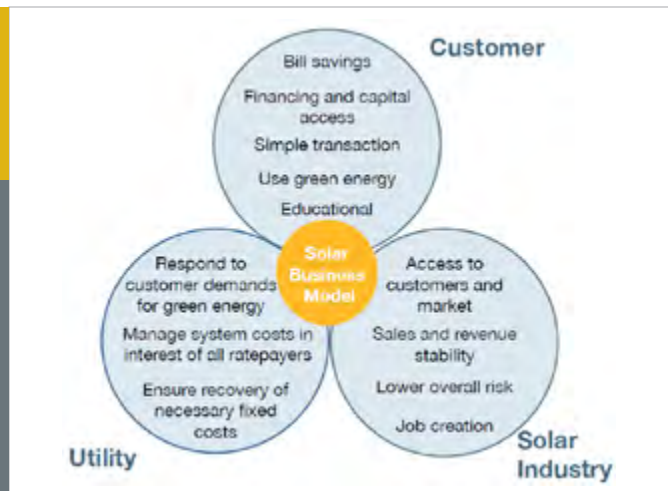

**FUNDING INFORMATION** \$0.68M | Soft BOS | 09/2011–08/2014

### Project Description

The Rocky Mountain Institute (RMI) is developing and pilot testing a new utility business modeling tool: EDGE—the Electricity Distribution Evaluator. EDGE is a MATLAB-based simulation tool designed to comprehensively assess the distributed energy resource value proposition in different regulatory and utility business model environments based on a detailed assessment of the technical and operational implications. With its SunShot funding, RMI has accelerated the creation and adoption of innovative approaches to utility regulation, rate design, and business models to enable high-penetration deployment of distributed solar photovoltaic (PV). New approaches are necessary to avoid conflicts between the interests of solar customers, utility ratepayers, utilities, and other stakeholders as penetration of solar PV increases. RMI will convene leading experts, policymakers, and industry thought leaders to identify best practice solutions to potential barriers, taking into consideration new technologies and value-creation opportunities in grid integration. RMI will disseminate information about best practice solutions to regulators, utilities, and other stakeholders nationwide. Intensive engagements with regulators and utilities in targeted states will accelerate innovation, implementation, and learning in areas with high penetration of solar PV.

### Individual Reviewer Comments

- The emphasis on utility engagement for distributed generation is critical to the success of these technologies. The study's goals and objectives are impressive. The project is an important and strategic piece in understanding solar's role in the market.

- The created models and analysis on the value of solar will be extremely valuable for increasing the investment in solar, especially by utilities.
- The project team including a vertically investor-owned utility and a generation and transmission cooperative is a strength of this effort.
- The identification of the value drivers utilizing the EDGE model provided an analytical basis to evaluate both the costs and values of distributed PV. Specific instances where EDGE identified high-value PV applications would have been helpful, as utilizing PV to rectify distribution system hot spots is not viable.
- The U.S. Department of Energy should invest more dollars in identifying the barriers to utility investments and focus more of the budget on aligning incentives and improving solar benefit cost assessments. In addition, this initiative should be better funded and more expansive.
- The cost reduction impacts are a bit unclear. Also unclear is what outcome or tools will be available aside from the value of the solar tool.
- The value of the solar tool is not necessarily validated by a third party.
- It is difficult to see how these insights will be applied across a highly diverse national regulatory and supply-side landscape, drawing from only two utilities. It is extremely tailored to two utilities.

## PROJECT: 5354 HAWAII DEPARTMENT OF BUSINESS

*Hawaii's Clean Energy  
Transformation and Grid  
Connection*



**FUNDING INFORMATION** \$0.70M | Soft BOS | 09/2011–08/2014

### Project Description

The Hawaii State Energy Office, housed within the Hawaii Department of Business, Economic Development and Tourism (HDBEDT), will use SunShot funds to support a technical review committee (TRC) to provide technical assistance and advice to the Public Utility Commission (PUC) on grid interconnection-related tasks, advised by the Reliability Standards Working Group. TRC staff will evaluate and further refine the findings of the reliability standards studies developed by Hawaiian utilities, and then establish technical reliability standards. To the extent that the existence of reliability and/or curtailment challenges of integrating more variable renewables—including feed-in tariff resources—on any of the islands served by the Hawaiian Electric Companies are validated, this award will support HDBEDT in performing and managing state utility commission studies by qualified technical entities to identify near-term, mid-term, and long-term solutions for each island, and work to implement those solutions as quickly as possible. The award will also support updates to Hawaii's state clean energy permitting tools.

### Individual Reviewer Comments

- This initiative is very important, not only for the benefits it can deliver to Hawaii, but also for the benefits it can deliver to the rest of the country. Since Hawaii is facing grid integration challenges before most other states, the work it does to improve interconnection processes and standards and to resolve reliability challenges as renewable energy penetration levels increase could be shared with other states and utilities in the future. Therefore, the potential impact of this initiative is very significant, assuming the results can be effectively disseminated

and applied in other states. Engagement with many local stakeholders from industry, utility, and PUCs are strengths.

- Understanding the impact of high-penetration solar is a key step in the continued expansion of solar on the grid. In addition, the team is making the permitting wizard open source for implementation by other jurisdictions. The project has the potential to have a third-party validated impact of solar model that is open source.
- The team seems to be doing a lot with limited funding. The team is taking a multipronged approach that includes near-term and long-term strategies for addressing high-penetration PV and the continued growth of solar.
- The permitting wizard and permitting advice/resource elements of this project are not particularly unique—there are similar efforts around the country—but improvements in permitting processes should reduce solar implementation costs, consistent with SunShot Initiative objectives. Permitting efforts are more descriptive than prescriptive.
- The funding level for this project is the weakest component. The budget for the activities could be doubled and continue to provide value to the U.S. Department of Energy and the State of Hawaii. The proactive grid-evaluation and permitting wizard are particularly impressive components of this initiative. The group has conducted an impressive amount of work for the funds it has been provided; given the efficiency in their work, additional funding to further develop its core initiatives and to expand the proactive grid-evaluation efforts across jurisdictions (beyond Hawaii) are recommended.

## PROJECT: 6128 YALE UNIVERSITY

### *The Influence of Novel Behavioral Strategies in Promoting the Diffusion of Solar Energy*

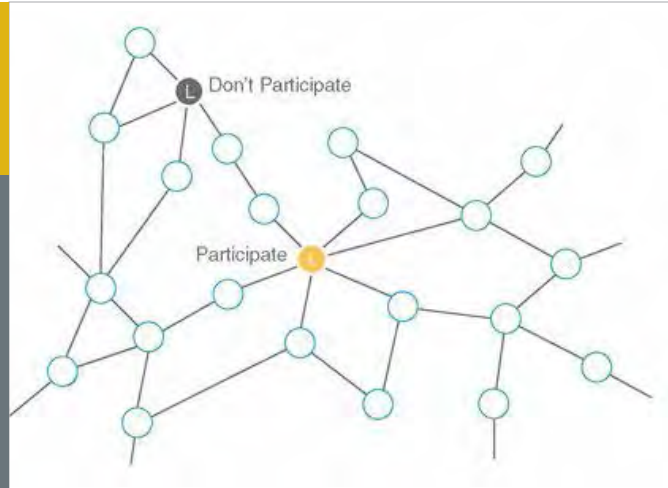

**FUNDING INFORMATION** \$1.9M | Solar Energy Evolution and Diffusion Studies | 04/2013–03/2016

## Project Description

Communities across the United States are instituting Solarize programs in which homeowners band together to collectively purchase rooftop solar systems. This project is quantifying the effectiveness, cost effectiveness, and scalability of this and other strategies that leverage social interactions to accelerate diffusion of solar technologies. Researchers from Yale University and New York University are designing and running a series of randomized field trials to study the new Solarize Connecticut program. The field tests are being implemented with partner SmartPower.

## Individual Reviewer Comments

- The premise for this project appears to be very strong and consistent with showings in the energy efficiency sphere regarding the potential for behavioral influence in customer adoption.
- A strength of this initiative is the partnership between an academic institution (Yale) and a nonprofit advocacy organization (Smart Power). Smart Power will be working to disseminate the information developed by Yale via public outreach “campaigns.”
- The project has an excellent strategy to understand how to reduce marketing costs for higher market demand. Moreover, the team has a good outreach plan that involves developing guidebooks for policymakers, businesses, and the general public, which will be distributed and shared via conferences.
- The impact of the behavioral and social networking strategies as opposed to the independent effect of various incentives is unclear. For example, financial incentives had the largest impact on customer decisions to install solar. Did it matter whether a friend shared the information about the financial incentive or if it was explained by an installer?
- The Solarize model is a strong strategy for reducing costs and increasing deployment. It is unclear how randomized tests in Connecticut have broader applicability. This will depend on local market conditions and barriers, and each Solarize deployment should be tailored.
- Cost variables and relative maturity of the market over time are large and harder to control. There is no cost share. The project could possibly leverage funds from Connecticut funds.
- In general, projects targeting marketing approaches should be designed in combination with industry practitioners to ensure they are being designed with pragmatic and realistic uses.



## PROJECT: 6129 UNIVERSITY OF TEXAS AT AUSTIN

*Toward an Emergent Model of Technology Adoption for Accelerating the Diffusion of Residential Solar PV*



**FUNDING INFORMATION** \$0.50M | Solar Energy Evolution and Diffusion Studies | 04/2013–03/2016

### Project Description

The goal of energy market transformation is to identify and target existing market barriers. Comprehensive analysis is needed to quantify peer influences, information dissemination, and other factors that, in addition to technical and financial factors, are barriers to major adoption. For this project, university researchers are acting as visiting scholars, or scholars in residence, hosted by six Texas electric utilities. Researchers have access to rich datasets that are enabling them to analyze real-world market barriers. The results will inform a pilot project that the researchers will run with partner utilities.

### Individual Reviewer Comments

- This research provides a novel approach to modeling the photovoltaic (PV) diffusion system. The identification of the nonfinancial barriers to PV adoption could potentially provide the information needed to increase residential PV adoption.
- This analysis is necessary to understand end-user barriers to solar adoption. The study would benefit from a wider regional analysis and commentary on how to extrapolate these findings beyond the Texas market.
- The study uncovers some very interesting findings, but the methodology is very opaque—especially in terms of how the equations and theories can be applied in the field.
- It is not clear from the research as to how significant the nonmonetary costs are on the decision making of residential PV adopters. If the magnitude of the monetary considerations far outweighs the nonmonetary considerations, the relevancy of this research is diminished. It is unknown whether or not the findings of this research will be transferable to markets outside of Texas.

## PROJECT: 6130 SRI INTERNATIONAL

### *Helios: Understanding Solar Evolution through Text Analytics*

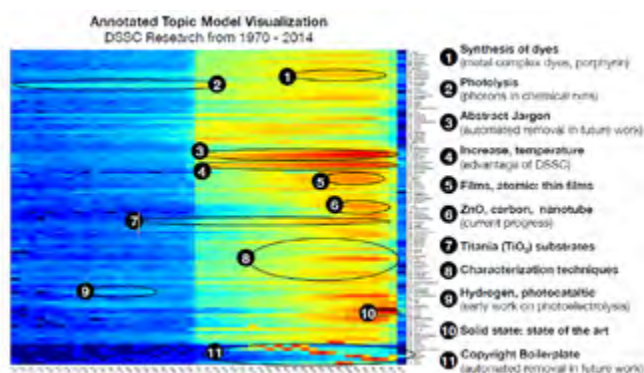

**FUNDING INFORMATION** \$0.60M | Solar Energy Evolution and Diffusion Studies | 04/2013–06/2015

## Project Description

Machine learning is a powerful computational tool that underlies an array of complex tasks from weather prediction to email spam filtering. By reading and organizing a massive amount of data from disparate sources, the tool can uncover and exploit buried patterns in the data. For this project, SRI is developing the Helios platform to detect unseen technological breakthroughs and bottlenecks for solar technologies by analyzing decades' worth of scientific publications and patents.

## Individual Reviewer Comments

- This initiative is very intriguing and, if successful, could provide extremely valuable information by identifying patterns for technology breakthroughs that might otherwise be lost in the thousands of pages of hard-to-access technical texts.
- It seems that there should be other, more interactive ways to understand trends, particularly by conferring with academic leaders in these technological disciplines. Beyond reducing the amount of time to do background research/case studies, this tool enables a more objective (and possibly accurate) recollection of the basis of breakthroughs than interviews with the principal researchers.
- The project team has a strong opportunity to create a tool for technological breakthrough analysis, but it is unclear how the tool will help solar in the future to understand how solar operated in the past, rather than analyzing industries that are similar in terms of remaining breakthroughs needed. In particular, historic improvements in solar are mainly hardware, while the remaining soft-cost issues can better learn from other industries' soft-cost reductions.

- The conventional method control result will be interesting. It is assumed this will incorporate national and international citations.
- It is unclear how the citation context models that evaluate new theories relate to understanding points of efficiency improvements in practice.
- The project could be stronger if shared insights from how partner GE and other leading innovators analyze the cost-reduction opportunities for various technologies.
- The team is using the partners—e.g., GE—just to help the case study accuracy. The next phase can be improved by encouraging the researchers to partner with private-sector research and development to learn about how they approach this type of innovation-enhancement research.
- It is not entirely clear how an automated tool will help point toward new inflection points, or help to understand the dynamics of past points.

## PROJECT: 6131 MASSACHUSETTS INSTITUTE OF TECHNOLOGY

### *Evaluating the Causes of Photovoltaics Cost Reduction: Why Is PV Different?*



**FUNDING INFORMATION** \$0.49M | Solar Energy Evolution and Diffusion Studies | 04/2013–03/2016

### Project Description

For half of a century, photovoltaics (PVs) have experienced a 20% cost reduction every time cumulative production doubles. This rate of technological improvement is unmatched by other competing energy technologies. Yet, there exists no practical explanation for this empirically observed trend. This project is investigating a wide range of hypotheses for describing the technology evolution process to form an overarching theory that can be applied to accelerate cost reductions in solar.

### Individual Reviewer Comments

- If successful, this research could be powerful by providing direction and insights to scientific researchers. It appears that it will be useful in understanding the sources of cost reductions and possibly informing research and development (R&D) and engineering design decisions. However, it is not clear how the effectiveness of this initiative will be measured.
- The project is helpful at the macroenergy economics level, but it is unclear how the research will contribute directly to SunShot deployment goals. Examples of how outcomes could be used to direct funding and research going forward would be beneficial. It seems that results will be of primary interest for research academic as opposed to applied market developments.
- The team has a very ambitious goal to advance understanding of mechanisms for technology cost reduction. The question is how to reduce future cost reductions, so it is important to look at other technologies that have similar types of barriers that remain for PV and see how those were reduced. The soft-cost categories of

this research are bundled in permitting, inspection, and contracting, but it would be helpful to tease out each of these as their own variable to allow for a closer view of soft-cost R&D needs. One big question remains on how a better understanding of historic PV cost reductions will inform future cost reductions.

- Researchers should be careful to contextualize their findings within the fact that nearly all energy technology projections have been wrong, so they should consider how their research plan needs to be different. Perhaps the team should expand to compare it to other technologies by looking beyond the energy sector and including fields that might be more mechanically similar (e.g., information technology systems rather than combustion turbines). A comparison would be helpful, especially if they could compare cost changes in the hardware and soft costs in distinct categories.
- The bundling of permitting, inspection, and contracting is because that is how the National Renewable Energy Laboratory (NREL) is giving them the information. If NREL can disaggregate that data, they could analyze them. It does not seem to be part of the plan, so it may be worthwhile to push the next two years on comparing the analysis.

## PROJECT: 6133 UNIVERSITY OF NORTH CAROLINA AT CHARLOTTE

### *Forecasting and Influencing Technological Progress in Solar Energy*

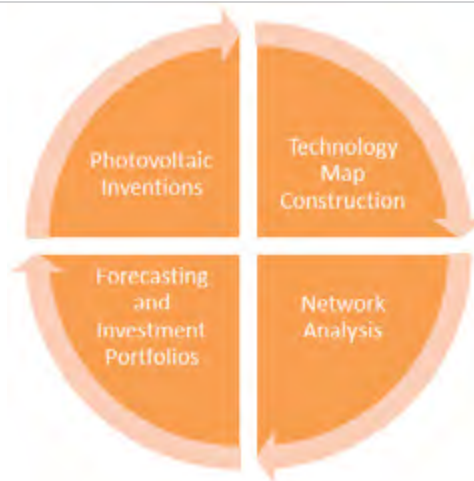

**FUNDING INFORMATION** \$0.95M | Solar Energy Evolution and Diffusion Studies | 04/2013–03/2016

### Project Description

Researchers from the University of North Carolina–Charlotte, Arizona State University, and the University of Oxford aim to make better forecasts of future cost reductions for new energy technologies. By abstracting the process of technological progress as a time-varying network of interconnected components, the team is employing a new theory to help inform optimal investment strategies in the research and development pipeline. This will help the industry more quickly and cost-effectively achieve technical and deployment goals. By analyzing hundreds of years’ worth of patent data and historical cost and production data, the team is constructing a network—called a “technology ecosystem”—to forecast and influence technological progress.

### Individual Reviewer Comments

- The use of technological ecosystem theory, as it relates to photovoltaic (PV) development, is a novel approach. This highly theoretical work may be used to predict cost reductions in the future.
- This project is a compelling piece of academic work. The analysis of and focus on technical innovation via patent filings and network analyses is very insightful. However, the specific application of this work, and its relevance to decision making and soft-cost reductions, was less clear. The reviewer is skeptical of the impact this work will have on solar adoption despite its value as a piece of scholarship.
- Direct and intentional efforts should be made to disseminate this work in the business and inventor communities to really gain the full value of this study. The usability of information by market and industry seems extremely unclear at this point.
- A weakness of this work is that it is unknown how this predictive model will actually impact the reduction of soft costs. If the SunShot Initiative’s goal is to reduce balance-of-system soft costs, it is not clear that this funded research will result in the lowering of these costs.
- It is unclear why this project was included in the “soft costs” category, as it seems to have more to do with hard costs or overall investment in solar technology.
- It is unclear what the outcome of the project really is. The objective is to remove the “black box” inherent to “experience curve” methodology, but the connection between PV-related patents and cost reductions are not clearly made.
- The project seems to be missing a clear step of patents “network” to real-world implementation (or justify why this step is unnecessary). Within the analysis, there are some methodology concerns; specifically, the grouping of polycrystalline and amorphous-based technologies, which have very different sub-technology ecosystems. In short, it is difficult to see how this study allows for better forecasting of PV costs and technology development, or how it solves the “black box” nature of experience curves.

## PROJECT: 6305 CLEAN ENERGY STATES ALLIANCE

*New England Solar  
Cost-Reduction Partnership*



**FUNDING INFORMATION** \$1.5M | Rooftop Solar Challenge 2 | 11/2013–05/2016

### Project Description

The New England Solar Cost-Reduction Partnership will build a thriving regional solar market by increasing coordination across Connecticut, Massachusetts, New Hampshire, Rhode Island, and Vermont; refining and deploying innovations developed in Connecticut and Massachusetts during Rooftop Solar Challenge I; and more widely implementing best practices across the region, including online permitting and group purchasing programs.

### Individual Reviewer Comments

- The project is a multistate effort with a focus on harmonization of cost-reduction strategies. In addition, this initiative is predominantly an information/best practices-sharing initiative. It makes a lot of sense to share the developments of some states that are in the forefront of tackling solar cost challenges, particularly states that participated in the first round of the SunShot Challenge. It is hard to tell at this point how effective the regional coordination/sharing initiatives will be. It seems like financing, interconnection standards, and purchasing efficiencies should be able to be applied regardless of state boundaries. Permitting, planning, and zoning may face more specific local/state political considerations. It would be interesting to know whether there are other regional bodies in New England that could also be used to disseminate the information that is being developed through this project.
- The objectives and goals of the proposal are needed; the information supporting/clarifying the activities is weak. As a reviewer, it was unclear what this project is doing, specifically, to meet its goals. Similar to other efforts, the outcomes associated with their outreach efforts are not well defined, and as a result, it is not clear if there is a true benefit to the activities of the organization. All Rooftop Solar Challenge II grantees need clearer guideposts and evaluation standards for their grants. Like education and information initiatives, we understand that they have market value, but the market benefits of U.S. Department of Energy awards in this category of grantees need to be supported by clear strategies, better data tracking, and performance monitoring.
- The approach seems scattered without any real metrics in place to measure progress (beyond dollar/watt installed). The reviewers would also like to see more measurements on the direct effects of the project.
- State-specific initiatives do not seem to be thought out in the context of the region. Rather, the project is just pursuing local initiatives with broader regional information sharing within this project.

**PROJECT: 6306**  
**CITY UNIVERSITY OF NEW YORK**

*NYSolar Smart*



**FUNDING INFORMATION** \$1.4M | Rooftop Solar Challenge 2 | 11/2013–05/2016

## Project Description

NYSolar Smart will create a toolkit of policies, programs, and resources to enable jurisdictions, utilities, industry, and end users to reduce the time and cost of installing solar photovoltaic (PV). These include Web-accessible permitting, virtual net metering guidelines for master-metered buildings, group purchasing programs, and updated model zoning ordinances. NYSolar Smart’s information technology (IT) tools will include a customizable customer acquisition portal, solar maps, market analytics, and a one-stop PV market portal.

## Individual Reviewer Comments

- The project has a promising impact on New York State with demonstrated success with building departments and utilities. Strengths include data-driven progress goals and reporting.
- The social and human capital model is promising, and for a state as complicated as New York, it may be an appropriate approach. Further, its ability to onboard investor-owned utilities is impressive.
- This initiative has significant promise because it offers a combination of standardization and flexibility—recognizing both the cost-effectiveness of sharing standard methods, with the need to customize solutions based on regional and local differences. New York is undertaking a comprehensive approach and addressing technical, market, IT, and human resource challenges. The “one-stop PV market portal” and Web-accessible permitting systems offer significant potential for reducing barriers, particularly in new markets.

- Progress seems to be completely dependent on established relationships, leading to some concern of post-grant sustainability of efforts.
- The project lacks a clear vision and strategy, including a failure to identify target outcomes of its activities and the goalposts it aims to reach. The theory behind the social and human capital development is not clearly delineated, as it is unclear how these working groups meet the state’s goals to improve balance of system, what the goals of these groups are, and what the cost-related metrics are.
- While this proposal offers a range of initiatives that can individually and/or collectively make an impact on reducing the soft costs of solar development, it is difficult to gauge how effective the initiatives have been to date. There are no benchmarks or other data points provided. Significant effort (and likely resources) is expended on process management (workgroups, ombudsmen, etc.)—which may be necessary to enable localized applications—but the costs of using this approach should be evaluated against the resulting benefits.

## PROJECT: 6307 WASHINGTON STATE DEPARTMENT OF COMMERCE

### *Pacific Northwest Solar Partnership*



**FUNDING INFORMATION** \$1.7M | Rooftop Solar Challenge 2 | 11/2013–05/2016

### Project Description

The Pacific Northwest Solar Partnership aims to double photovoltaic capacity in Washington and Oregon by creating a more uniform and vibrant regional solar market. The collaborative project will establish “solar-ready” corridors and simple online permitting and common interconnection processes for 80% of residents. The effort will also continue to expand innovative, locally developed financing solutions, such as community solar and Solarize group purchasing programs, to provide access to financing options in every utility territory in the two-state region.

### Individual Reviewer Comments

- This research is being conducted at the state level. Working at this level improves the likelihood of the standardization of permitting, interconnection, financing, and planning across jurisdictions within Washington and Oregon. The four workgroups that were developed have already achieved positive outcomes.

- The team has an excellent strategy and is targeting key stakeholders on key topics. The project could have a broader base of states to enhance impacts.
- Net metering should be included in this effort. The Northwest Solar Communities has momentum and net metering should be addressed concurrently in order to achieve the goal of 152 megawatts by 2016.
- The project’s shortcoming is that it is not spending time coordinating with other similar efforts in the country to standardize when possible, so funds should be provided to do this.

**PROJECT: 6308  
OPTONY INC.**

*American Solar Transformation Initiative*

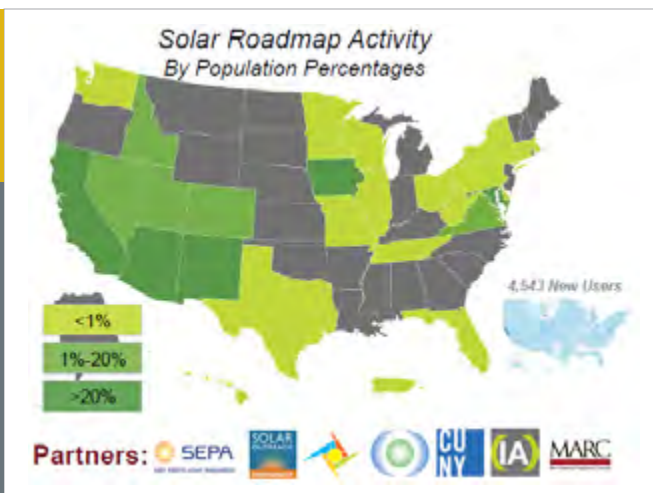

**FUNDING INFORMATION** \$2.6M | Rooftop Solar Challenge 2 | 11/2013–05/2016

**Project Description**

The American Solar Transformation Initiative will use an innovative online solar roadmap platform and hands-on engagement to assist more than 400 jurisdictions where solar potential is abundant, but resources and information are scarce. The project will improve permitting processes, establish solar-friendly planning and zoning guidelines, streamline the interconnection process, expand financing options, and ultimately develop strong solar markets across the country.

**Individual Reviewer Comments**

- This project has an excellent technical service that is very helpful and is deserving of greater than \$500,000 per year given its exact alignment with the SunShot goals.
- The project demonstrates a strong approach and platform to support authorities having jurisdiction, though it may have overlap with some other partner initiatives aimed at local jurisdictions.
- Utilizing the existing solar roadmap platform infrastructure to build customized roadmaps should reduce the amount of time to adopt best practices by cities, counties, utilities, and regional organizations.
- The project includes cost share, but does not appear to have sufficient funds to provide necessary outreach to stakeholders. The U.S. Department of Energy should consider giving the initiative funds for subgrants to users to have them share their experience in their relevant professional training circles, including utilities, national parks, urban planning, and the Conference of Mayors.

- The partnership with environmental nongovernmental organizations should be considered for potential political liabilities, especially since this is a red-tape cutting effort that can appeal across the political spectrum, but that type of partnership with one type of political stakeholder may taint the value of the program.
- The team can strengthen outreach outcomes by defining the number of users to reach per year. The project has a sole focus on residential, but should also include commercial rooftop projects. It is unclear how it will achieve self-sufficiency.
- The biggest weakness for all the streamlined permitting projects is that they don't have the staff time built in to ensure standardization between regional groups. A huge opportunity is lost by not having these groups try to standardize as much as possible and only have differences in regional differences and policy ideologies. This can be done by giving them the requirement to consult with the other groups and try to agree to best practices, as much as they can—and this can be done cheaply by giving 5%–10% staff time to do by phone, Web, or email.



## PROJECT: 6309 BROWARD COUNTY, FLORIDA

*Go SOLAR Florida*



**FUNDING INFORMATION** \$1.6M | Rooftop Solar Challenge 2 | 11/2013–05/2016

### Project Description

Go SOLAR–Florida will expand its market-leading online permitting solution to nine local municipalities and six additional Florida counties, and will continue to engage Florida stakeholders to expand financing options in the state as it unlocks its full potential as a leader in photovoltaic deployment.

### Individual Reviewer Comments

- This program's focus on standardization for zoning and permitting can overcome significant market barriers to solar adoption. In addition, the emphasis on stakeholder working groups is a critical and necessary step to achieving success in this initiative. Further, if successful, this will prove to be an effective model for other regional efforts to coordinate permitting and zoning practices to support market adoption and create a hospitable contracting environment for solar. In addition, the program's bottom-up grass roots mobilization approach is a powerful one in a state resistant to adopting solar-friendly market strategies.
- This single-state focused program works to share experience among leading early adopter counties in Florida. Its primary focus on reducing permitting and zoning barriers/costs will help to reduce soft costs of development. Given similar permitting work that is being funded in other SunShot initiatives, Florida should augment its work by reviewing the permitting tools and processes that have been developed from some of the other funded initiatives. It is unclear if the marketing component of the Florida initiative (geared primarily toward attracting additional solar development) focused

on addressing the key soft-cost challenges. Perhaps some of those funds could be more tightly targeted to publicize and disseminate findings related to permitting and zoning improvement.

- The initiative should also consider developing more education and information that has the potential to outlive the grant in order to support statewide efforts.
- In general, the harmonization of local permitting is an extremely valuable effort. This project seems to have shown early initial success, but it is unclear how much of that success is scalable beyond the counties it is currently working with, especially outside of Florida.
- It is unclear how marketing solar through a local event will help the primary objective of lowering permitting costs. The project does not seem to have established metrics for measuring success.
- While the grantees indicated the funding level could be increased, it was not clear how funds would be applied. Further, the grantees should consider strategies to expand this effort to additional counties and leverage this initiative to effect greater change in the state.

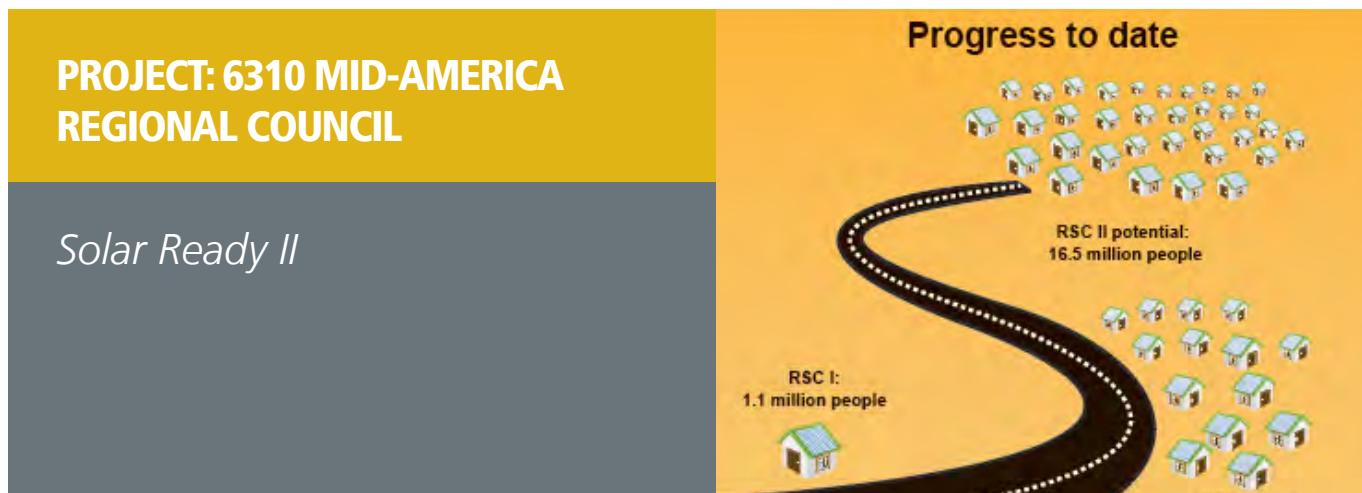

**FUNDING INFORMATION** \$2.6M | Rooftop Solar Challenge 2 | 11/2013–05/2016

## Project Description

The Mid-America Regional Council and the National Association of Regional Councils will use established and trusted relationships among regional planning councils and local governments to spread solar-friendly best practices to nine diverse regions across the country, building upon successful efforts in the Kansas City region to create a strong solar market.

## Individual Reviewer Comments

- The project has an excellent strategy and demonstrated impact. In addition, this research is very relevant. The reduction of soft costs at the local governmental level is essential for the widespread adoption of photovoltaic. Building off the success of Solar Ready KC through disseminating the 16 identified best management practices is a valid approach.
- Another strength of this award is that the data indicated an 11%–27% decrease in installed costs from 2011–2012. Utilizing the lessons learned by developing the 16 best management practices and disseminating this information through this award should provide replicable results.

- It is unclear how the cost reductions cited are due to general market conditions versus interventions by the team.
- It is uncertain how regional planning commissions (RPCs) are key at the project level. Support for broader adoption and removal of barriers is key, but RPCs (unlike municipal utilities) do not have infrastructure and utility budgets. It would be good to provide more documentation on projects facilitated.
- The project needs time for staff to compare and standardize their best management recommendations with what is being suggested in other projects.
- The U.S. Department of Energy should consider providing more funding given the potential for replication and the current diverse and large set of actors.
- The goal of facilitating a national solar policy will be very difficult, if not impossible. This research should continue to focus on local jurisdictions through the dissemination of the tools necessary to implement solar-friendly best management practices.

## PROJECT: 6312 CALIFORNIA CENTER FOR SUSTAINABLE ENERGY

### *Golden State Solar Impact*



**FUNDING INFORMATION** \$1.3M | Rooftop Solar Challenge 2 | 11/2013–05/2016

### Project Description

The Golden State Solar Impact Project will transform California's solar market by making permitting and interconnection processes more uniform, rapid, and transparent across the state. The project will implement a standardized permitting process and develop tools, such as a statewide interconnection and data portal, to dramatically reduce soft costs in California.

### Individual Reviewer Comments

- The project's overall goals are very much in line with reduction of soft costs, especially permitting costs. In addition, project progress seems positive.
- The California initiative tackles three important cost areas: permitting, interconnection, and financing. If successful in reducing these barriers and disseminating the information, this initiative could have a significant impact.
- The project is pursuing consistency across the state, which could be an efficient approach for developing and sharing best practices, but could also forego locally developed and potentially more targeted approaches. It was good to hear that the four rooftop and two regional initiatives are coordinating and sharing information through a "base-camp" online tool and periodic calls.

- There is an effort to engage local advisors and participants in the financing project through creation of city and regional advisory committees. Perhaps these local organizations could also be consulted on area-specific permitting and interconnection challenges and concerns.
- Outreach and dissemination of materials to the market seem very relationship-oriented and difficult to assess sustainability of efforts.

## PROJECT: 6327 ELECTRIC POWER RESEARCH INSTITUTE, INC.

### *Leveraging Industry Research to Educate a Future Electric Grid Workforce*

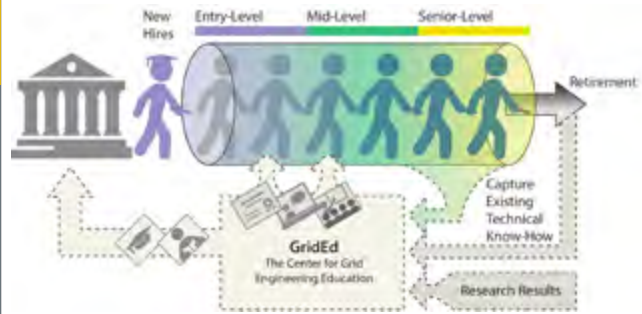

**FUNDING INFORMATION** \$4.2M | Grid Engineering for Accelerated Renewable Energy Deployment | 10/2013–09/2018

### Project Description

The Electric Power Research Institute (EPRI) will define and develop educational offerings for all levels: high school students; undergraduate and graduate students; practicing engineers pursuing a professional master's degree or graduate certificate; and mature and experienced engineers keen on understanding and developing skills to design, plan, operate, and protect the evolving energy systems that constitute the smart grid. To accomplish this task, EPRI will rely on previous and ongoing high-level research within the project team. The implementation phase will have undergraduate and graduate program components, as well as a variety of custom-tailored short courses, tutorials, workshops, symposia, open-access courses, and other methods of delivery in accordance with the program priorities set in consultation with our utility members for the benefit and development of all aspects of their diverse workforce.

Consortia: Georgia Institute of Technology; Clarkson University; University of North Carolina–Charlotte; University of Puerto Rico–Mayaguez; Central Hudson Gas and Electric; Consolidated Edison, Inc.; CPS Energy; DTE Electric Company; Duke Energy; First Energy; Lincoln Electric System; LG&E and KU; National Grid; New York ISO; New York Power Authority; and Southern Company Services.

### Individual Reviewer Comments

- This research is highly relevant. If the grid is to evolve to accept distributed technologies in general and photovoltaic (PV) specifically, the grid will need to transform. The project scope is comprehensive, and the five-year

award duration for this research is needed to develop and deliver the proposed education modules.

- Preserving and leveraging existing knowledge is good but insufficient; as the saturation levels grow, there are many new approaches and challenges to be addressed. The project may be a bit too legacy heavy.
- The project has a relatively high budget without direct identification of the new materials, training, and research that will take the industry forward. Energy efficiency, demand response, and consumer information are all elements that need to be included in comprehensive analyses.
- It is very concerning that the government is giving the utility industry subsidies to develop educational curriculum without public interest stakeholder oversight. If the U.S. Department of Energy (DOE) wants students educated about solar, it needs to have better options available, and if the agency wants to do it via utilities, the very least is that the curriculum should be developed in partnership with DOE or other public-serving entities.
- The utility and industry sponsors were not identified in the summary. It is critical that electric utilities and industry professionals are included when developing the curriculum. The development of relevant education modules hinges on the inclusion of this industry.
- EPRI does not have a public advisory board for this effort, and that's highly concerning. State utility commissioners oversee the grid integration plans and workforce training budget lines, yet are not included in the

oversight of this project, so I suggest adding them to the advisory board to help identify priority issues, as well as including an outreach event to National Association of Regulatory Utility Commissioners with the results.

- No compelling argument was made of the need to interview retiring engineers when the goal is to bring in new knowledge about new systems that old engineers do not have as much experience with. It seems like they

are using government subsidies to do the knowledge transfer of other types of information, not solar, and that type of historical knowledge maintenance can be funded by other state-approved ratepayer funds for ongoing utility service.

- This product seems to help deployment of PV systems rather than directly reducing levelized costs of energy.

## PROJECT: 6333 NATIONAL RURAL ELECTRIC COOPERATIVE ASSOCIATION

### *Solar Utility Network Deployment Acceleration*

**A. 1MW Template design:**

1. Design specifies a 1.4 MWp / 1 MW-AC system with a fixed-tilt ground-mount array.
2. 300W crystalline modules at 1,000VDC.
3. The power electronics package includes two 500 kW inverters and a medium voltage grid connection (nominally 12-47 kV).
4. Systems cost on target to meet goal of \$2.00/W, by end of Phase I (Sept. 2014).

**C. Consolidated Purchasing:**

NRECA National Discounts Program has solicited participation from targeted PV equipment vendors, including module, inverter and structure manufacturers. Negotiated prices on track for Phase I goals.

**B. Business Models:**

Developed a plan to document ownership models and cost recovery mechanisms (including various forms of community solar) of interest to co-ops.

**FUNDING INFORMATION** \$3.6M | Solar Utility Networks: Replicable Innovations in Solar Energy | 10/2013–09/2017

## Project Description

The National Rural Electric Cooperative Association (NRECA), with its partners the National Rural Utilities Cooperative Finance Corporation, the Federated Rural Electric Insurance Exchange, and Power Secure, will work closely with a cohort of 15 rural electric cooperatives in 17 states to integrate more than

23-megawatt solar assets rapidly and cost-effectively. The team helps accelerate solar adoption at electric co-ops through standardized designs, streamlined financing, packaged insurance, group equipment purchasing, and extensive training and outreach. The number and diversity of cooperatives that are participating in this program is impressive. Not only are the co-ops geographically diverse, but they also differ in the number of customers they service, workforce, and solar expertise. The team has an aggressive target of getting to a solar installed cost of \$1.6/watt without subsidies by 2017. The project is designed to help lower the cost of solar deployment across rural America. The impact of NRECA's work will be felt beyond the more than 900 cooperatives serving our rural communities in bringing de facto standards for integrating solar assets in rural communities.

Participating cooperatives include: Anza Electric Cooperative, Inc. (CA); Brunswick Electric Membership Corp. (NC); CoServ Electric (TX); Eau Claire Energy Cooperative (WI); Great River Energy (MN); Green Power EMC (GA); Maquoketa Valley Rural Electric Cooperative (IA);

Oneida-Madison Electric Cooperative (NY); Owen Electric Cooperative (KY); Pedernales Electric Cooperative (TX); Plumas-Sierra Rural Electric Cooperative (CA); Sandhills Utility Services, LLC (NC); Sussex Cooperative (NJ); Tri-State Generation & Transmission Association (CO); and Vermont Electric Cooperative (VT).

## Individual Reviewer Comments

- This is a terrific initiative, and its focus on achieving economies of scale through purchasing and the national discounts program should facilitate significant cost savings for participating cooperatives.
- The standardization of system designs is also very promising. It saves the expense and time of each cooperative developing its own system specifications.
- The team is doing an excellent job targeting a stakeholder group that can use this type of assistance. The project has good geographic diversity and covers cooperatives, which are an important market. The team has a strong strategy by having it be led by cooperatives.
- The effort to find applicable financing incentives that can be used by nonprofit cooperatives could yield significant cost-saving results. As this project is in its beginning phase, it would be useful to develop performance metrics so a detailed evaluation can be completed when determining whether the program should be extended to reach additional cooperatives in the future.

- It is great that the project team is in touch with the U.S. Department of Agriculture (USDA) on if the new Rural Utilities Service (RUS) funds can be used. It would be good to have the U.S. Department of Energy (DOE) engage USDA to see if DOE can influence RUS rules to include this type of program.
- A weakness of this program is that it does not include exploration of resident-owned systems. In addition, engineering and procurement standard documents may end up creating a “one-size-fits-all” problem. Guidance with some templates and how to modify to meet local conditions may be helpful. Business models (e.g., shared solar) and integration (with energy efficiency, demand response, or tariff reform) for cooperatives are also critical needs that could be called out more.

**PROJECT: 6339  
ELECTRICORE, INC.**

*Southwest United States of America - Distributed Technology Training Consortia (SWUSA)*



**FUNDING INFORMATION** \$2.3M | Grid Engineering for Accelerated Renewable Energy Deployment | 10/2013–09/2018

**Project Description**

Southwest United States of America (SWUSA) will create power and energy systems training, curricula, and workforce preparedness through the inclusion of data collection and analysis, power systems expertise, and application-specific training activities that build on fundamental principles, modeling and simulation tools, field-immersed training, and methods of performance validation. The outcome of the program will result in better prepared and greater numbers of graduates ready to contribute to the field of power systems, which depends upon the safe, reliable, and efficient generation sources that make up an increasingly diverse mix of renewable power. Additionally, the program will deliver critical training modules that are intended to support mid-career professionals and be woven into utility training programs used across the country.

Consortia: University California–San Diego; San Diego State University; Arizona State University; University of Hawaii–Manoa; San Diego Gas & Electric; Southern California Edison; Pacific Gas & Electric; Maui Electric Company; Lawrence Berkeley National Laboratory; and California Independent System Operator Corporation.

**Individual Reviewer Comments**

- This consortia brings together an impressive team that can leverage the highest concentration of renewable resources in the United States. Team members are responsible for the operation of and data collection from five independent microgrid installations and other distributed technologies.

- Utility members are developing new control methodologies to incorporate systems that control a mix of generation and storage technologies. Exploiting this consortia’s real-world experience will help to modernize legacy power system engineering curriculum.
- The leveraging of five existing microgrids is positive and greater detail or early results from those would be helpful. A framework for gap analysis with some examples would also be helpful.
- This project has leveraged relatively high cost share, large markets. Greater emphasis on the efficiency demand response and tariff structure impacts for microgrids would be a useful addition.
- The board includes the California Independent System Operator Corporation, but it does not have other public interest groups, so it should be encouraged to add more.
- Mid-career, as well as student training materials, are positive. However, while they are coordinating with a national group, they are not strategically coordinating the curriculum development, so duplication is being funded.
- If the federal government is going to subsidize utility employee training (and future employees), the government should ensure that the funding is being strategically targeted at how to reduce soft costs for utility-owned solar, as it is twice as high as third-party providers, based on Californian experience.
- A weakness of this award may be that it is premature to utilize the power-energy virtual laboratory, as it was just recently developed. Using this laboratory as a tool to perform exercises from distant locations may be over ambitious.



## PROJECT: 6340 UNIVERSITY OF CENTRAL FLORIDA

*FEEDER: Foundations for Engineering Education for Distributed Energy Resources*



**FUNDING INFORMATION** \$3.2M | Grid Engineering for Accelerated Renewable Energy Deployment | 10/2013–09/2018

### Project Description

The Foundations for Engineering Education for Distributed Energy Resources (FEEDER) center will help establish cross-institutional smart grid curriculum, facilitating research collaborations among its academic, utility, and industrial partners, and incorporating the latest and most relevant research findings into new educational materials and courseware. The new power systems engineers and engineering faculty emerging from FEEDER will accelerate the deployment of distributed renewable energy technologies onto the electric utility grid. FEEDER will also research technological components such as distributed control, optimization, advanced communication, renewable generation, and smart grid integration.

Consortia: University of Central Florida; Auburn University; Florida State University; University of Arkansas; University of Florida; University of Kentucky; University of South Carolina; National Renewable Energy Laboratory; Los Alamos National Laboratory; Southern Company; Duke Energy; Florida Power & Light; Tennessee Valley Authority; Kentucky Power; Orlando Utilities Commission; Lakeland Electric; East Kentucky Power Cooperative; ABB; LEIDOS; L-3 Communications; Mitsubishi Power Systems Americas; Northern Plains Power Technologies; OSIsoft LLC; S&C Electric Company; SAIC; Schneider Electric; Siemens; and United Technology Corp.

### Individual Reviewer Comments

- The approach to supporting development for massive open online course and remote learning is appropriate and promises to multiply impact. Examples of course objectives and outlines should be shared as they're developed. The project demonstrates a strong network that includes industry and university participants.
- The project offers a good use of leveraging utility funds and limiting government funds to new curriculum and sharing. Moreover, the shared approach of employing distance learning and online learning media is a strength of this grant. This way, each university can share the developed curriculum more easily. This is a modern approach of course delivery that reduces costs for the student and increases the availability of the curriculum.
- The collaborative team consists of educational institutions, national laboratories, utilities, and industrial companies. However, it is unclear how training utility power engineers is reducing soft costs for solar.
- The advisors are all utilities with one representative from a municipal commission and a manufacturing company. The project therefore lacks participation from state utility commissions, independent system operators, solar developers, and solar installers—all of whom are key stakeholders in this field and should have some oversight of federal funds in this jurisdiction. The curriculum being developed should apply to employees in those other sectors where the bulk of the soft costs actually reside.

## Balance of Systems/Soft Costs

- The project team is beginning to do one summer course for electricians (and utility engineers; it's not clear if they are actually electricians) who want to learn more about solar. Mostly, all participants are engineers. The U.S. Department of Energy should encourage more training of electricians/installations if there isn't an oversaturation from American Reinvestment and Recovery Act of 2009/U.S. Department of Labor funds.
- The lack of identified priorities for education modules is a weakness. I would like to see more detail in this area. It may be difficult for this diverse team to coalesce and converge on specific topics, as well as agree on solutions to current distributed generation issues.

## PROJECT: 6341 MISSOURI UNIVERSITY OF SCIENCE AND TECHNOLOGY

### MARMET: MidAmerica Regional Microgrid Education and Training



**FUNDING INFORMATION** \$4.3M | Grid Engineering for Accelerated Renewable Energy Deployment | 10/2013–09/2018

### Project Description

The MidAmerica Regional Microgrid Education and Training Consortium (MARMET) will integrate cutting-edge research and advanced instructional methods to create a flexible, evolving approach to microgrid training for all levels of students. Scalability, reliability, stability, controllability, and resiliency are just a few of the operational areas to be impacted, especially by electric utilities. Researchers globally are addressing these issues, but MARMET proposes to rapidly develop modular material to capture and reflect the newest trends in electric power engineering and to make it available in traditional and non-traditional settings.

Consortia: University of Illinois; Iowa State University; University of Wisconsin; Ameren Services; City Utilities; National Rural Electric Coop Association; and Perfect Power Institute.

### Individual Reviewer Comments

- The development of university short courses, workshops, and programs through the Perfect Power Institute is a strength. In particular, the novel approach of utilizing the Performance Excellence in Electricity Renewal (PEER) program to provide a certification process will be helpful in attracting industry professionals to taking the short courses.
- The assumed driver for the adoption of distributed generation technologies, including photovoltaic (PV) energy storage and vehicle to grid systems, is to optimize the legacy grid. This assumes electric utilities are proactively modernizing the grid. In general, utilities

look for ways to adapt to the customer's desire to utilize these technologies. It is unclear whether widespread development of microgrids will be a reality in the future. Whether utilities are proactive or reactive to distributed generation and battery storage will change the nature of the curriculum.

- Microgrids are not very relevant to PV today, given that the overwhelming majority of microgrids are powered by combined heat and power with natural gas or biomass base. There is the potential to make more microgrids have more solar, so that is the likely goal, but that is a niche market that will mainly apply to rich institutions with long payback periods—universities, hospitals—so less compelling of a public service goal. However, the microgrid market is clearly on the upswing and deserving of attention on how to increasingly add solar, so their approach of training engineers on it with a certification is a good one. It is important to have a clear sense of the market size reality and determine if the funding level is accurate for this size.
- This research is early stage, as the award duration is from 2013–2018. For example, the open model framework looks promising, but it is not entirely clear how it is tied into courses. As the research progresses, more detail regarding course offerings will likely be available to future reviewers. The lack of detail presented currently is a weakness of this award.

**PROJECT: 6342 INTERSTATE RENEWABLE ENERGY COUNCIL**

*National Network Administrator of GEARED*



**FUNDING INFORMATION** \$1.1M | Grid Engineering for Accelerated Renewable Energy Deployment | 10/2013–09/2018

**Project Description**

The Interstate Renewable Energy Council and Solar Energy Power Association co-lead the GEARED network, presenting innovative approaches and networking strategies to grow the expertise and preparedness of current and future electric utility sector professionals for high penetrations of solar and other distributed technologies. This unique partnership of utility and workforce expertise will connect utilities, clean energy businesses, educational institutions, and credentialing organizations as integrated national stakeholders.

**Individual Reviewer Comments**

- The project’s strength is its focus on student-centered work. It looks to develop mentoring, internships, and/or partnerships with participating utility transmission and distribution professionals to tighten the industry connection, making it strictly academic.
- This research is very relevant. Many utilities are concerned that high penetration of photovoltaic will adversely affect grid reliability, grid stability, and power quality. The approach of having a national network administrator that works with distributed technology training consortia so research development and training activities can be coordinated increases the likelihood of success. The creation of a national steering committee to provide oversight is critical. It is important that the national network administrator provide platforms for the distributed technology training consortia to communicate with each other regularly, to share lessons learned, and to prevent the duplication of efforts.

- The project team has only reached 19 students from 25 schools. PGE paid for students to participate. At the same time, utilities can pay for their staff training through ratepayer-funded expenses, so federal subsidies should be minimized and have cost sharing with the utilities.
- The government role in workforce training is best made for lower-income populations, which are not engineers. The target of training utility power engineers should be to reduce soft cost for utility ownership of solar, so projects should include that type of models and not just integration of third-party systems.
- A possible weakness is the lack of cost share in this award. Cost share should be available through industry, academic, and utility engagement.

## PROJECT: 25694 NATIONAL RENEWABLE ENERGY LABORATORY

### Soft-Cost Modeling and Analysis

Benchmarked Soft Costs and SunShot Target

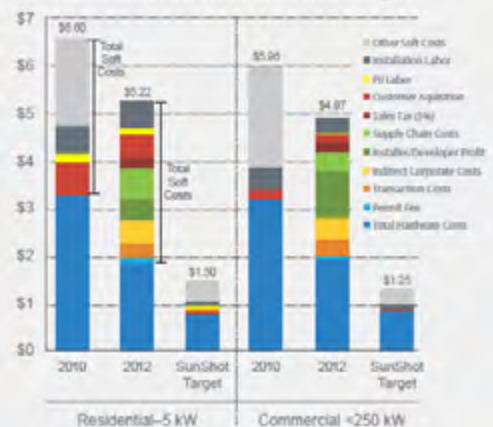

**FUNDING INFORMATION** \$4.5M | National Laboratory Research and Development | 10/2012–09/2015

### Project Description

Achieving the SunShot cost targets will require aggressive cost reductions in every aspect of the photovoltaic (PV) supply chain. In order to track progress and identify key pathways to reducing those costs, the U.S. Department of Energy and stakeholders need transparent and credible information and analysis to quantify soft and hard costs more accurately.

### Individual Reviewer Comments

- The proposed soft-costs monitoring and real-time feedback is critical to successfully driving policy decisions to support soft-cost reduction. The analysis of residential third-party-owned PV system soft cost will be groundbreaking as these data tend to be opaque.
- This research overlaps somewhat with the Lawrence Berkeley National Laboratory award. That being said, the unique attributes of this award, including the detailed comparative analysis of U.S. soft costs when compared with the PV soft costs in China and Japan, is a strength of this award.

- Benchmarking of soft-cost components continues to be an important task to tackle (prescriptive as well as modeling current). More timely data would be helpful in order to better inform industry.
- The weakness of this award is that merely reporting balance-of-system soft-cost trends, in and of itself, may not result in the lowering of balance-of-system soft cost. However, the tracking and reporting of balance-of-system soft costs is important to the overall portfolio of awards.
- The proposal does not clearly indicate channels used to disseminate this tracked information. Overall, the review period was too short for this specific soft-cost analysis to provide meaningful feedback on their efforts.

## PROJECT: 25695 NATIONAL RENEWABLE ENERGY LABORATORY

### *Advanced Financing Mechanisms to Achieve SunShot*

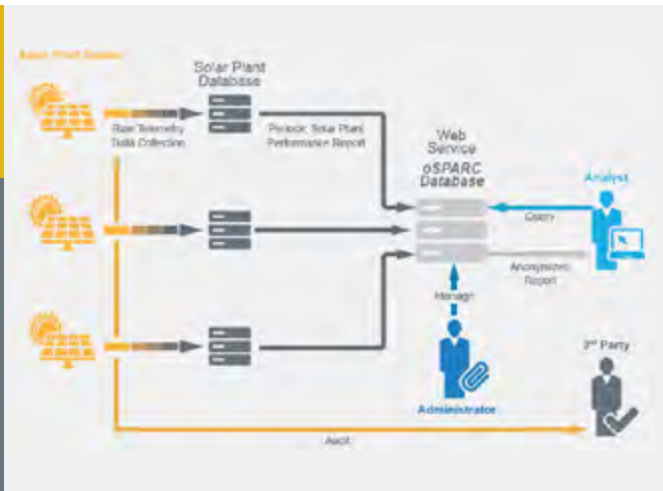

**FUNDING INFORMATION** \$4.0M | National Laboratory Research and Development | 10/2012–09/2015

### Project Description

The project is designed to expand the availability and lower the cost of capital to deploy solar installations in the United States. The project will standardize, inform, and provide data to investors, developers, lenders, regulators, rating agencies, and other stakeholders in the renewable energy community to enable wide-scale adoption of solar energy through low-cost, consistent, and ubiquitous financing opportunities. This effort will engage solar, legal, financial, and advisory industries to standardize solar lease and power purchase agreement documents; educate various stakeholders on system and credit performance; develop best practices for system installation, operation and maintenance, and independent engineering in order to facilitate investor confidence systems; and comprehend rating agency and investor risk perspective by engaging rating agencies to provide “shadow ratings” on mock portfolios of residential and commercial assets. To help create these products, the National Renewable Energy Laboratory (NREL) organized the Solar Access to Public Capital Working Group, an assembly of more than 150 leading organizations in the fields of solar deployment, finance, counsel, and analysis. Under this agreement, NREL also conducts thorough analysis of opportunities and barriers to capital market investment and bank lending for expanded solar deployment, and develops the datasets necessary to quantify the relevant risks enabling institutional investment in the asset class. Finally, NREL engages the banking industry to standardize solar loan documents, educate banks and their regulators on system and loan performance, and expand comprehension of best practices and activities in commercial Property Assessed Clean Energy programs in order to materially expand lending activity for solar deployment.

### Individual Reviewer Comments

- Financing models, and barriers to access, are central to high-cost measure installations. This project’s efforts toward mobilizing the financial markets to support solar leasing and solar as an asset class have the potential to cause significant market-wide impacts.
- Particularly impressive are the asset class mock assessments and the goal of obtaining a Standard & Poor’s value for solar. Its work on leasing structures and models is similarly impressive.
- This is an excellent initiative. The standardization of loan forms both reduces the effort and cost for each bank and project team, but also enables possible securitization. In addition, the work with the rating agencies, as well as on quality standards, should also help to reduce risk, and, as a result, financing costs.
- Creating a source of legal memoranda and documents can also reduce barriers to development of small projects. It may be helpful to include information in those “libraries” about public subsidy programs and regulatory mechanisms (e.g., tax credits, grants, Renewable Portfolio Standards, or net metering) that reduce the financial cost of a project and to explain how the different financing mechanism work together.

## PROJECT: 25696 NATIONAL RENEWABLE ENERGY LABORATORY

### *Policy Stacking and Foundational Analysis*

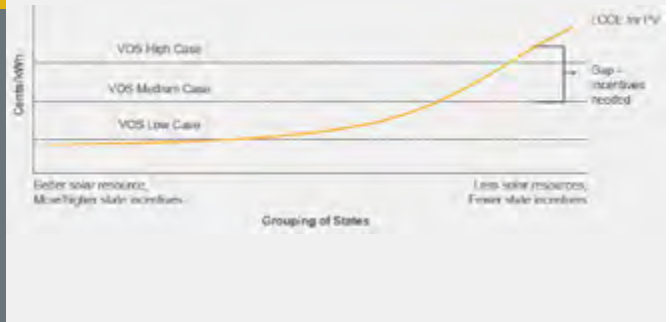

**FUNDING INFORMATION** \$1.2M | National Laboratory Research and Development | 10/2012–09/2015

### Project Description

National Renewable Energy Laboratory (NREL) researchers, in collaboration with Lawrence Berkeley National Laboratory, will coordinate a Policy Activities Advisory Team to provide insights, feedback, and refinement to the research and assist in communicating and disseminating research findings. NREL will also develop a variety of effective policy strategies, or “stacks,” in different jurisdictional governance and economic contexts and within different technology pricing scenarios and conduct analyses to identify and understand the impact and effectiveness of implementing policies that interact within the same markets. With respect to the regulatory environment, NREL will analyze the impact of utility rates on grid parity; explore options and considerations for equitably addressing utility system costs of solar; and address interactions between rate design, customer adoption, and the associated impact on utilities. NREL will also identify solar issues in utility supply procurement processes, explore a range of solutions that state and local policymakers could support, and create fair evaluation processes. Finally, NREL will conduct market-responsive analysis on topics such as voluntary markets that provide technology access; utility community solar programs; providing regulators information needed to identify pathways forward for dealing with increasing levels of distributed solar that are appropriate for their states’ context; net metering policies and caps; and possible approaches to address the expected expiration of maintenance of the California Solar Photovoltaic Database.

### Individual Reviewer Comments

- Important and broad topic areas are addressed as part of this project. Developing and disseminating effective solar policies across states is very important and can have a big impact in facilitating solar development. It appears from the documents that NREL is partnering with many of the key organizations that have the capacity to share the policy work and results among regulators and policymakers.
- It is unclear from the materials how many state officials are making use of this information—it would be helpful to see data on utilization. It is important to ensure materials are utilized by advocates who participate in regulatory proceedings. Regulators may think an idea included in a policy study or paper has significant merit, but if it is not advanced through a formal regulatory proceeding, there may be no way to adopt it. The project also needs to be clearer on how the large and comprehensive group of stakeholders is being engaged.
- There appears to be a bit of a back-casting emphasis on documenting growth of solar markets as opposed to looking forward to the critical policy issues around distributed generation rates, making storage, etc.
- The project has a relatively high budget without cost share for the number of stakeholders.

## PROJECT: 25698 SANDIA NATIONAL LABORATORIES

*Residential and Commercial Real Estate and PV Energy Systems*

<b>Property Information</b> Property Type: residential PV Project Type: existing Ownership: owned State: NM Zip Code: 87185 <a href="#">Exit Data</a>	Estimated Value Low: \$10,919.92 Estimated Value Avg: \$11,738.94 Estimated Value High: \$12,653.24
<b>Solar Resource Data</b> System Size: 5000 watts Derate Factor: 0.77 Module Warranty Yrs: 25 System Age Yrs: 0 Remaining Yrs: 25 Degradation Rate: 0.5 Array Tilt: 22.6 Array Azimuth: 180 kWh Produced/Year: 3,023 <a href="#">Exit Data</a>	<b>Google Map Location</b> 
<b>O &amp; M Expense</b> Inverter Size: 5000 watts Inverter Warranty Yrs: 15 Inverter Age Yrs: 0 Inverter Replaced: No Replacement Cycle Yrs: 15 Replacement Cost \$/kW (inverter): 55	

**FUNDING INFORMATION** \$0.55M | National Laboratory Research and Development | 10/2012–09/2015

### Project Description

Sandia researchers, in collaboration with Lawrence Berkeley National Laboratory, are compiling data on residential and commercial solar installation pricing in a home sale transaction and developing an appropriate valuation tool (an algorithm and Web tool) that calculates fair market value to solar installations that are part of a home/building. Sandia is pursuing an “income” approach to improve this Photovoltaic (PV) Value tool in order to accommodate more complex utility rate structures, lease to purchase options, utility rate escalation, and tax and revenue considerations. Sandia will correlate the PV Value tool’s “income” value estimates with actual PV property sales premiums to determine if, and to what degree, “income” drives sales prices. The team also prepared and is disseminating training materials for property appraisers.

### Individual Reviewer Comments

- This is a compelling study effort that is critical to establishing metrics for assessing PV home values. The information gained in this study is important for home and PV valuation, but also for lending and crediting purposes. The author’s attention to the assessment criteria and approach to standardizing their matching/ comparison standards with these widely used assessment metrics is appreciated.

- This project, in combination with the Lawrence Berkeley National Laboratory real estate valuation project, has significant potential in facilitating demand for solar energy investment and reducing transaction costs for financing. Through its updated PV valuation tool and their training of appraisers, the Sandia project is enabling the market for homes/buildings with solar to work better. There could be a justification for increased funding to expand access to the new Web-based tool.
- The team should continue to look for ways to expand utilization beyond the total download number of 4,000 users. The combination of the Lawrence Berkeley National Laboratory approach with Sandia’s “bot-toms-up” approach adds credibility to the valuations, which should support greater acceptance by financial institutions.
- The project has shown good initial successes. More data around adoption and use by the targeted audience would be helpful. By no fault of the authors, access to key solar markets was limited or denied and thus limits the applicability of the results to critical solar markets. In addition, an explanation on the connection between appraisals and reducing financing costs would be helpful.
- The budget for this effort seems high, even with the level of rigor and data aggregation requirements of the study. The project could likely be completed for two-thirds to three-quarters of the costs.



## PROJECT: 25699 SANDIA NATIONAL LABORATORIES

### *Reducing Project Risk through Analysis of Solar PV Reliability Data*

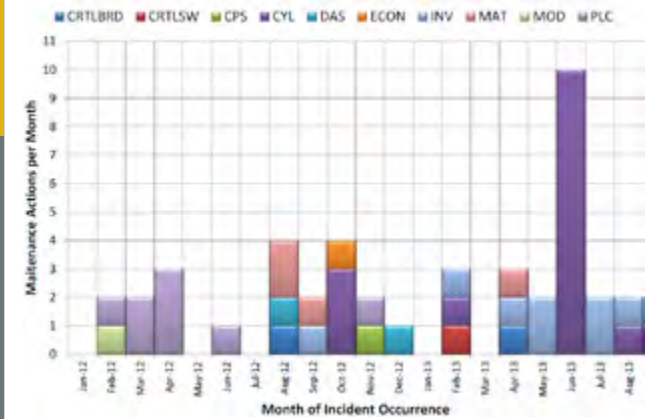

**FUNDING INFORMATION** \$1.3M | National Laboratory Research and Development | 10/2012–09/2015

## Project Description

This research builds a database of operational photovoltaic (PV) production in existing installations, eventually targeting 100 megawatts of long-term operating data. Through analysis of production and system maintenance, Sandia's research will help delineate the actual maintenance costs and optimal maintenance schedules for various sizes and configurations of PV equipment, helping to reduce uncertainty and risk in financing and insuring PV installations. The work refines the PV Reliability, Operations & Maintenance (PVRM) database and calculator, an open-platform tool to track reliability.

## Individual Reviewer Comments

- The project addresses a very important piece of solar value and risk through best practices and empirical analysis. It digs into root cause analyses and insights. In addition, open working groups to share insights and develop best practices is a valuable effort. This study also provides invaluable information on large scale PV reliability, which is already demonstrating its value to the market. The work could more clearly indicate whether its objectives will provide operations and maintenance (O&M) best practices to reduce failures/reliability issues through this data.
- The concept of the “preventative maintenance” supports predictive maintenance to support the improved overall O&M. The project includes a project with 40 distributed systems, 1-megawatt systems, among others. The tools appear to be useful for asset owners. An additional benefit is the inclusion of financing entities to support lending security assessments. The benchmark report will provide the distribution of fault and failure systems.

However, the study would also benefit from greater transparency into the percentage of the market that is represented in its activities—both in terms of types of solar sites, as well as the market actor's share of the market when dealing with specific investor-owned utilities and original equipment manufacturers.

- The ability to estimate lifetime O&M schedules should lower the levelized cost of electricity by increasing lifetime energy production, improving bankability of systems, and reducing insurance premiums. Working with PV system owners and operators to develop a standardized data entry, analysis, and reporting framework could help the industry begin to more effectively share O&M data. The PVRM database elements will lead to standardized activities and best practices.
- Although PV O&M is critical to the long-term viability of the PV industry, it is unclear how this work will result in balance-of-system soft-cost reductions. Thus, the weakness of this award is its funding mechanism, through the soft-cost program of the U.S. Department of Energy.
- There has been good progress in terms of database recruitment for the project. However, it is unclear what types of assets are in the database and whether the data analyzed can be used for predictive maintenance. The database and recruitment of projects seem to be limited and therefore findings may be of limited use. In addition, the project requires very strong buy-in by data partners, which is concerning for the long-term maintainability of the data.

## PROJECT: 25700 SANDIA NATIONAL LABORATORIES

### *Solar Loads and Roofing Structures: When Is Additional Engineering Needed?*

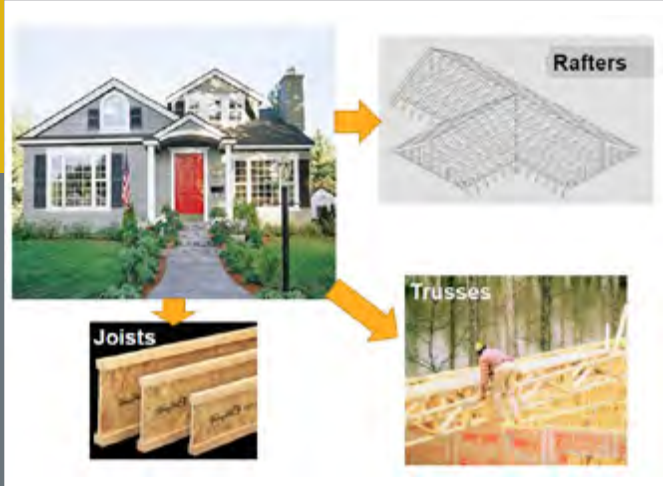

**FUNDING INFORMATION** \$1.4M | National Laboratory Research and Development | 10/2012–09/2015

### Project Description

In many jurisdictions, building inspectors require a stamped engineer's review of blue prints to assure that solar rooftop installations will not require structural upgrades to comply with building codes. This can add hundreds, if not thousands of dollars to an individual installation's cost. Through this agreement, Sandia tested the most common residential roof structures in U.S. domestic housing to determine actual load-bearing capacity based on applicable national structural regulations (e.g., ASCE 7–10) and developed mitigation designs as necessary to bring inadequate structures up to code. Sandia is now disseminating this information and educating solar professionals on structural aspects of rooftop installations through workshops, conferences, and publications in peer-reviewed and trade journals. In early 2015, Sandia will issue a final, nationally applicable Solar Structural Guide.

### Individual Reviewer Comments

- The strength of this research is revealing that the carrying capacity of roofs is greater when you take into account the sheathing and the rafter. This innovative approach could potentially assist engineers with residential photovoltaic (PV) dead-load analysis. Information from this project can also be integrated into the SunShot training initiatives.
- The project targets a small, but important intersection of hardware and soft costs. The tests performed in the laboratory and the data provided strengthen the argument that the engineering of residential roofs are conservative.

- The study is empirically estimating the true barrier of load-bearing capacity of residential households. Currently, engineers are handling the roof data to estimate actual stress and compare that with code to determine whether PV can be installed. The Sandia team aims to look at the roof as a system, not an independent structure, to determine the roof's capacity. In addition, the project aims to develop opportunities to reinforce load-bearing capacities to support greater adoption in field. The goal of the effort is also to offset structural engineering requirements in regional efforts by providing access to empirical data.
- It would be preferable to see guidelines for mounting structure manufacturers to use rather than a recommendation for installation type.
- Laboratory tests are important, but it would be good to have seen how applicable construction holds up in the field. The project also lacks publicly available empirical test data.
- It is not clear as to how often a homeowner is required to strengthen its roof prior to the installation of rooftop PV. However, when asked this question, Dr. Dwyer maintained that it was a big issue in Wisconsin, and that homeowners were denied permits unless their roofs were strengthened prior to PV installation.

## PROJECT: 25701 SANDIA NATIONAL LABORATORIES

### *Solar Glare Hazard Analysis and Siting Tool*

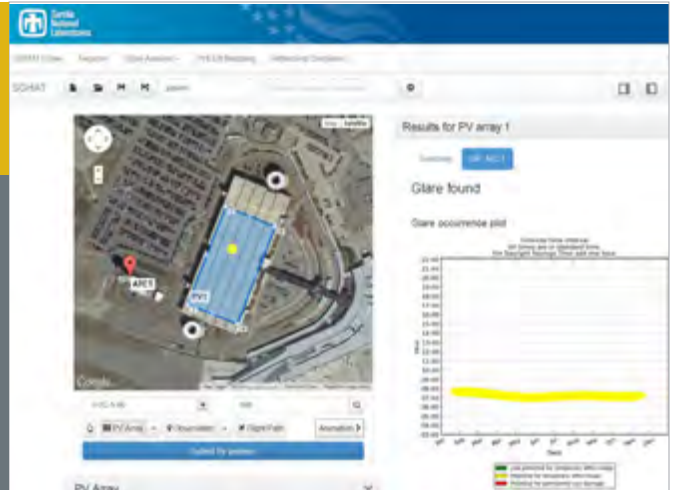

**FUNDING INFORMATION** \$1.1M | National Laboratory Research and Development | 10/2012–09/2015

### Project Description

With growing numbers of solar energy systems being proposed and installed throughout the United States, the potential impact of glint and glare from photovoltaic (PV) modules, concentrating solar collectors, receivers, and other components is receiving increased attention as a potential hazard or distraction for pilots, air-traffic control personnel, motorists, and residents (“Glint” is defined as a momentary flash of light, while glare is defined as a more continuous source of excessive brightness relative to the ambient lighting). Through this agreement, Sandia has developed a free, Internet-accessible tool (SGHAT, the Solar Glare Hazard Analysis and Siting Tool) that allows participants to input simple installation assumptions and orientation, and receive within minutes a detailed analysis of potential glint and glare by time of day and seasonally across the year for that installation.

### Individual Reviewer Comments

- This is a very interesting project and clearly important given the safety implications of glare and the possible barrier this issue could present toward solar development in certain areas. There is a nexus to reducing permitting and compliance costs by effectively screening possible glare issues before sites are selected for solar projects. It is impressive how quickly and easily the tool can be used to provide valuable siting information.
- The project addresses important barriers and appears to be a leading and needed tool. There is strong recognition for the tool’s technical development and it looks to be good for wide and even international dissemination.
- It is a great idea to proactively manage this, but the project is not related to soft-cost reduction. This is about reducing a backlash from certain institutions and avoiding a potential public backlash for safety conflicts. It is good to fund this project.
- It is not clear if there is cost share. Air, industry, and other stakeholder contributions could be leveraged. The team should spend time determining a path to financially sustain itself past U.S. Department of Energy funding.
- The project team is working with some city organizations to publicize the effort, but it would be good to make sure that they are also going to do outreach to the American Planning Association and other local permitting, city organizations to know about this important tool. The team should also consider spending future rounds in partnership with policy organizations to develop policy recommendations on how to address the glare problems.

## PROJECT: 25702 NATIONAL RENEWABLE ENERGY LABORATORY

*Solar Technical Assistance Team*

Technology Deployment

**Solar Technical Assistance Team**  
Through the Solar Technical Assistance Team (STAT), NREL provides research to help stakeholders understand challenges and barriers to the development of solar markets at the state and local levels. The STAT project map highlights these technical assistance projects that have helped communities across the United States. Select a state category or state to view technical assistance projects. Select a topic category of state to view technical assistance projects. The table below the map shows all the results in the selected category.

**Show Projects by Category**

All Categories

Finance

Policy and Program

Technology and Resources

[Show Results](#)

**Apply Today**  
NREL offers various technical assistance if you are a state or local government.

**Nebraska**

**Policy and Program**

**Technical Assistance Requested:** (1) Analysis of PV financial incentives and programs for the State Energy Office (SEO). The SEO wants to foster the development of consumer solar markets and to create a solar-friendly policy structure. (2) Analysis of PV financial incentives. Nebraska has a state energy loan program but mostly funds wind projects. The SEO wants to examine how to structure state energy incentives and loans for consumers and utilities.

**Results:** (1) NREL will write a three-part white paper on immediate solar utility programs for non-regulated utilities specific to total demand in Nebraska. State policy options to develop consumer solar market, and a review of other investment policy considerations.

**FUNDING INFORMATION** \$3.0M | National Laboratory Research and Development | 10/2012–09/2015

## Project Description

This agreement helps provide broad introductory information to policymakers and implementers, as well as deep, specific policy development and impact information to directly facilitate market development and technology deployment within jurisdictions. This agreement provides the foundational, unbiased, and in-depth research from which technical assistance responses are tailored to produce decision-support information for policymakers and implementers. The technical assistance performed by the National Renewable Energy Laboratory (NREL) (and the Lawrence Berkeley National Laboratory as a subawardee) is coordinated with other SunShot technical assistance efforts, such as the Solar Outreach Partnership program, to ensure broad access to experts and critical information upon request to state and local decision makers across the country who are addressing opportunities and challenges associated with an expanding solar market and increased deployment.

## Individual Reviewer Comments

- NREL is providing effective policy support through two different strategies: first by providing foundational training to policymakers (which is always necessary given the frequent turnover of state regulators and policymakers) and second by providing targeted assistance on specific proceedings (such as the Los Angeles net metering proceeding).

- There is a significant need for expert engagement in state regulatory proceedings so new ideas can be proposed and properly supported in regulatory proceedings. NREL has the expertise to provide that type of support.
- It is commendable that NREL has sought to measure the impact of its initiatives by surveying the users of its services. NREL should seek to coordinate with state and regional organizations that are also providing technical and policy assistance, so as to avoid duplication of effort and resources and to maximize the reach of technical assistance resources.
- There is some overlap with what other regional partners are proposing in terms of support for local decision makers. The project does not have cost sharing.
- The solar technical assistance model is a great one. Technical assistance could be organized thematically and identify emerging issues. In addition, another way to improve it is to have a phone number and email available for quick technical assistance, as to even reduce the barrier of submitting the application. The information on the application can be completed by the NREL staff member who receives the call. By eliminating the application, users are more likely to get actual quick response type inquiries. NREL staff said they are open to doing the “ask an expert” model.

## PROJECT: 25703 LAWRENCE BERKELEY NATIONAL LABORATORY

### Soft-Cost Modeling and Analysis

#### Annual Report Series: Providing Basic Information to Support Decision-Making

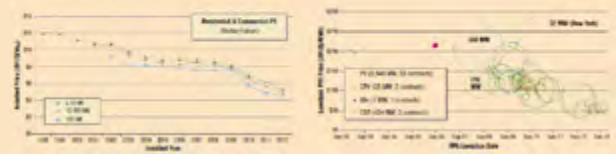

**FUNDING INFORMATION** \$2.2M | National Laboratory Research and Development | 10/2012–09/2015

### Project Description

Lawrence Berkeley National Laboratory (LBNL) researchers, in partnership with the National Renewable Energy Laboratory (NREL), will collect, synthesize, analyze, and disseminate comprehensive data on the installed price of United States photovoltaic (PV) systems via its annual Tracking the Sun report series and derivative journal articles and outreach activities. LBNL researchers will also track and analyze the installed utility-scale solar cost, price, and performance data—a rapidly growing sector of solar deployment. Finally, LBNL and NREL will partner with academic researchers to pursue innovative, “deep-dive” research projects, such as an analysis of the impact of city-level permitting processes on residential PV prices and development times, and conducting a comparative analysis of residential PV system prices in the United States and Germany.

### Individual Reviewer Comments

- The overall strength of this award is the development of research products that inform policy and market decisions. These publications will report on potential pathways for further balance-of-system soft-cost reductions. Furthermore, balance-of-system soft cost research and analysis will be published through this award. *Tracking the Sun* is a very popular report that is downloaded by all who are interested in in-depth analysis regarding solar costs. It is unclear whether the mere reporting on soft and hard costs will result in future cost reductions. However, the portfolio would be lacking without an award that reports on cost reductions over time.

- More clarity on this initiative and how it differentiates itself from the studies it cites as source material is needed. It also needs to be made clear how this analysis will be utilized by the U.S. Department of Energy (DOE) and in market, and how the team will ensure that the information it is generating will be disseminated and made available outside of DOE and its existing reach in the solar market.
- Benchmarking balance-of-system costs associated with PV systems is necessary to ensure improvements, and LBNL's studies have provided leadership in these efforts; the approach seems to rely on historical databases, which may not accurately reflect true PV costs. Additional benchmarking of component costs is desirable, especially with a study on how these vary across installation types and regions.

**PROJECT: 25704 LAWRENCE BERKELEY NATIONAL LABORATORY**

*Policy Stacking and Foundational Analysis*

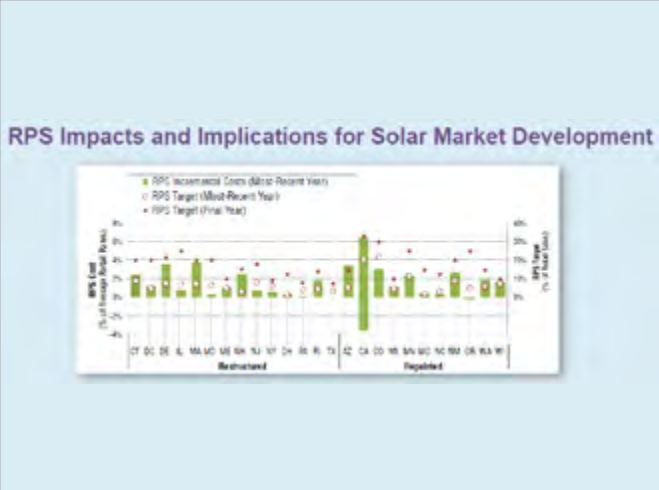

**FUNDING INFORMATION** \$4.7M | National Laboratory Research and Development | 10/2012–09/2015

**Project Description**

Lawrence Berkeley National Laboratory researchers, in collaboration with the National Renewable Energy Laboratory, will analyze policy developments, compliance costs, and impacts as they relate to solar energy within state Renewable Portfolio Standards, third-party tax equity, third-party ownership, and federal tax policies. In addition, this project will conduct analysis of key issues at the intersection of solar deployment, utility regulation, and retail rate design to address the market drivers associated with customer electricity bill savings.

**Individual Reviewer Comments**

- The policy analysis and technical assistance provided through this initiative can play an important role in facilitating adoption of solar development policies. The Renewable Portfolio Standard and third-party financing policy work are very relevant and necessary today.
- The project has strong and relevant results and empirical analysis to address emerging issues. The budget is also at an appropriate level.
- While there is presently a lot of contention surrounding the question of utility profitability as it relates to distributed photovoltaic, it is unclear that studying the issue is the most productive use of limited SunShot dollars. However, if this research focus continues, it would be interesting to see what impact the potential utility profitability mitigation strategies (referenced in the paper) would have on demand for behind the meter solar (e.g., what impact would an increase in fixed charges have on a customer’s decision to invest in a behind the meter solar system?).

- The research on utility impact will be incredibly helpful for many states. The utility profit tool should also look at a variable return on equity, with higher rate for solar and clean energy, and lower rate for conventional generation, and see what the total outcome is based on likely volume. The project should also consider using the profit tool to explore different types of performance-based regulation compensation models, since that is being considered by several states now.
- This data collection and presentation provides an excellent service to policymakers. The data provided to policymaker audiences are typically overwhelming and lack a focused analysis on policy design lessons. There is a wealth of information in this research, and it can be significantly more helpful if more attention and money are provided to help tease out the action-oriented policy lessons. It is unclear if the compliance costs are likely related to the state’s portfolio ratio of coal, natural gas, and nuclear. Knowing this information will help the reviewers extrapolate an expected cost of compliance for states with similar fuel mix portfolios.
- The research needs to be explicit about compliance cost differences being largely influenced by the electricity base rate and therefore other states with dissimilar rates should not draw lessons from them.

## PROJECT: 25705 LAWRENCE BERKELEY NATIONAL LABORATORY

### *Residential and Commercial Real Estate and PV Energy Systems*

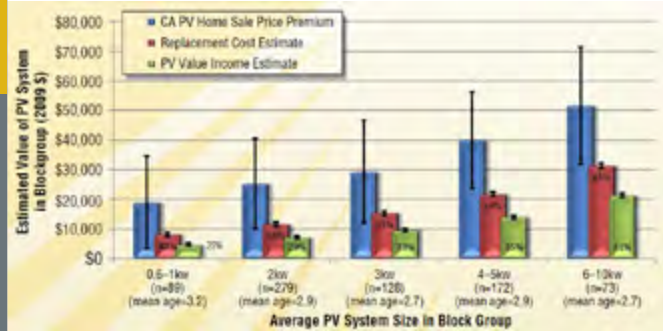

**FUNDING INFORMATION** \$0.60M | National Laboratory Research and Development | 10/2012–09/2015

## Project Description

Lawrence Berkeley National Laboratory (LBNL) researchers, in collaboration with Sandia, are compiling data on residential and commercial solar installation pricing in a home sale transaction and developing an appropriate valuation tool (an algorithm and Web tool) that calculates fair market value to solar installations that are part of a home/building. LBNL is pursuing a “cost” approach in developing a method for estimating historical average net-installed costs of photovoltaic (PV) systems, as well as labor and building costs, and correlating those net-installed “cost” estimates of PV systems to actual PV property sales premiums to determine if, and to what degree, “cost” drives prices. This agreement addresses two SunShot objectives: decreasing costs by expanding access to low-cost financing options and addressing policy and regulatory barriers to increase deployment.

## Individual Reviewer Comments

- This initiative has the potential to remove significant barriers to residential and commercial distributed generation and PV adoption. The tool development, depending on the overall valuation results, can play a significant role in assessments to help onboard new customers. The project also has great potential in facilitating demand for solar energy investment. By providing information about the impact of solar investments on real estate pricing, the project can help make the market work better. All three of the options they list could be valuable, particularly an analysis of the impact of leasing

agreements on housing resale. The combination of the LBNL approach with Sandia’s “bottoms-up” approach adds credibility to the valuations, which should support greater acceptance by financial institutions.

- After sales of existing systems is beginning to be an issue in major markets, and understanding home premiums derived from PV will be a factor in ensuring the marketing of new and existing systems will be appropriate; while the results will be intriguing, questions about how much this actually impacts the sale of PV should be answered as well—it is difficult to assess how much this will bring down the cost of PV systems.
- The project’s key strength is that it is an open-source tool with clear commercialization and ongoing support in place. However, it was unclear how much this effort will bring down soft costs and the measurement of impact on PV sales. Additionally, the overall budget is too low to support analysis across two sectors.
- The project’s key weakness is in the commercialization plans. For the purposes of this effort, it is not clear how this research and the associated tool will be used beyond the life of the project. The commercialization of this effort is a central component to the sustained use and applicability of this research and should be a key requirement for future tool-based work funded by SunShot.

# PROJECT: 26153 SANDIA NATIONAL LABORATORIES

*Design of Social and Economic Incentives and Information Campaigns to Promote Solar Technology Diffusion through Data-Driven Behavior Modeling*



**FUNDING INFORMATION** \$2.3M | Solar Energy Evolution and Diffusion Studies | 04/2013–03/2016

## Project Description

The project team, including researchers from Sandia National Laboratories, the University of Pennsylvania Wharton School, the California Center for Sustainable Energy, Vanderbilt University, and the National Renewable Energy Laboratory, is developing an approach for designing social and economic incentives to enhance solar diffusion. The team is integrating individual-level data about solar adoption patterns with data generated from laboratory and field experiments and surveys to construct an individual-level computational model to predict solar adoption. They are using the model to drive agent behavior in an agent-based simulation, with agents' interactions captured using social influence variables. The team will use the model to forecast adoption patterns in response to alternative policy interventions and use computational optimization techniques to arrive at candidate policies.

## Individual Reviewer Comments

- The combination of database, survey, and focus group, while remaining focused on an area with strong adoption and controlled economic variables, is important. Unlocking customer motivations for going solar, especially absent economic incentives (e.g., rebates), is also extremely important in expanding the residential market and lowering customer acquisition costs.
- The use of predictive modeling is an innovative approach widely used in other outreach for-profit efforts. This project is compelling; it combines social norms and other proven motivation strategies with the use of predictive models and real-world experiments to test and validate the work.

- This project has the potential to be a groundbreaking effort across the clean energy field. Its learnings leverage those gained in energy efficiency, though its work is in the public sphere and will likely be taken up more readily than similar efforts conducted in the private sector.
- The development of a multidisciplinary data approach is a strength. Using the results to develop predictive simulations to make data-driven forecasts is an approach that will provide replicable advertising campaigns and promote photovoltaic adoption. An additional focus on outreach may be necessary.
- The budget for this project is exceptionally high relative to what would be expected for this type of analysis, even as sophisticated as this project appears to be, which looks to amount to mostly survey-based work and some model building.
- The findings that sticker shock, impact of retirement and neighborhood impacts, are already well known. It would have been beneficial to have seen new events that were less understood in their findings. The team also needs to run deeper analysis on causative versus correlated predictive analysis.



## PROJECT: 26154 NATIONAL RENEWABLE ENERGY LABORATORY

### *Understanding the Evolution of Customer Motivations and Adoption Barriers in Residential Photovoltaics Markets*

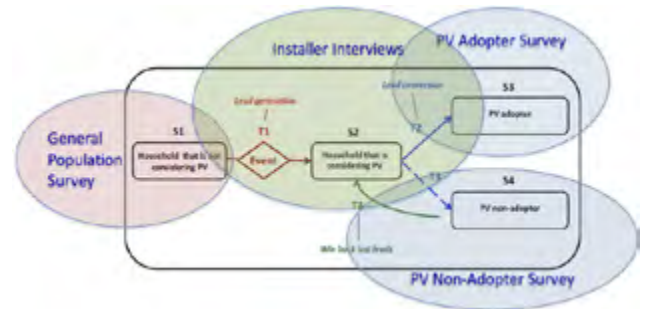

**FUNDING INFORMATION** \$2.3M | Solar Energy Evolution and Diffusion Studies | 04/2013–06/2016

### Project Description

Decisions of whether to adopt rooftop solar are driven by many factors, including system price, access to information, and the experiences of peers within social networks. Analytical models for projecting market growth typically only account for the price variable, and no other important decision parameters. An agent-based model can elucidate the ways that photovoltaic markets will evolve by simulating the complex and interrelated decision dynamics of individuals in a social system. This project, led by the National Renewable Energy Laboratory (NREL) and in collaboration with researchers from Portland State University, the University of Arizona, and other institutions, is collecting a rich dataset that is being used to train regionally specific, agent-based models to simulate decision making under different test scenarios, and to run real-world pilot tests that validate results with market partner Clean Power Finance.

### Individual Reviewer Comments

- The team has a fantastic strategy with potential for large impact to reduce soft costs of marketing. It is unclear if the research can be translated into action-oriented recommendations for industry, local government, state government, federal government, and Public Utility Commissions. The project can benefit by adding an outreach plan for sharing results with relevant stakeholders.

- Given that only 10% of solar leads are converted to sales, there are significant transaction costs in getting customers to take the first step of installing solar. This project is helping to identify the reasons for customer avoidance. The next step of undertaking market pilots to demonstrate new methods for breaking through this impasse could be very useful. NREL should coordinate with the Yale researchers regarding their work on behavioral influences.
- The project addresses distributed generation driven by understanding of customer motivations and economics. It provides an empirical analysis of data from several markets can have broad market strategy development impacts. It includes strategic dummy variables on financing and tax credits.
- As of now, the team is only evaluating normative and environmental messaging. The team should add in nuanced financial messages, as financing is a primary motivator at this point. The team can also do a better job in developing an outreach plan to engage more practitioners beyond those participating in their study.

## PROJECT: 27329 ARGONNE NATIONAL LABORATORY

### *Long-Term Monitoring of Utility-Scale Solar Energy Development and Application of Remote Sensing Technologies*

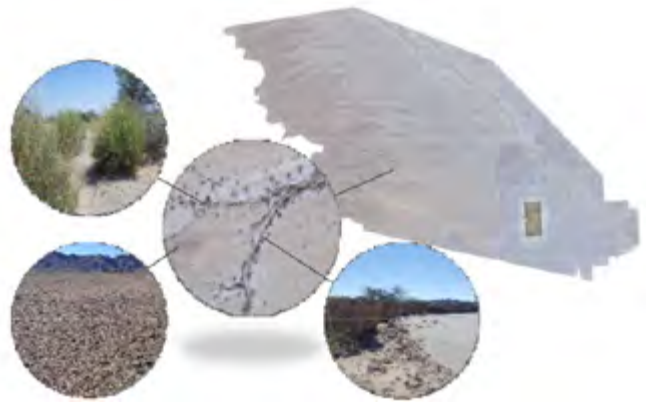

**FUNDING INFORMATION** \$0.38M | National Laboratory Research and Development | 11/2013–09/2014

### Project Description

To date, a comprehensive approach to long-term monitoring for utility-scale solar development in the desert southwest has not been established. Under this agreement, Argonne National Laboratory's researchers are developing appropriate, cost-effective approaches for long-term monitoring of potential environmental impacts, including the evaluation of (1) actual direct, indirect, and cumulative impacts compared to predicted environmental impacts; (2) the effectiveness and/or appropriateness of measures taken to avoid or minimize impacts at the project site; and (3) the effectiveness of regional, compensatory mitigation investments. As part of this effort, Argonne is partnering closely with the U.S. Bureau of Land Management, which is actively engaged in developing such programs for solar development in designated solar energy zones on public lands. Ultimately, this agreement helps lay the foundation for rapid and streamlined installation of large-scale solar on public lands, lowering the costs and helping to double renewable energy generation again by 2020.

### Individual Reviewer Comments

- This is a novel approach to long-term monitoring of utility-scale solar energy development. This research is relevant over the long-term viability of utility-scale solar development as it relates to environmental impacts over the life of the photovoltaic (PV) system. The environmental community must feel comfortable with utility-scale solar energy development. The integration of the 2014 dataset in conjunction with satellite imagery is also a very interesting approach.
- The team will collaborate with industry stakeholders. The team is developing partnerships to identify and test collaborations and partnerships among developers and organizations.
- The project uses high-resolution imagery to evaluate environmental features. The study is focused on developing priorities with information streams for the siting tools. The project will have an open-source tool as its primary output.
- This project may be critical to cost-effective, large-scale monitoring as solar energy development becomes more widespread. The environmental impact is a key concern for interveners and stakeholders. This is the first effort to monitor degradation over time with site develop and land degradation. It also facilitates early detection of degradation to support mitigation efforts.
- The project addresses a key piece in utility development, but needs a clearer indication of how this addresses concerns of environmental permitting costs and efforts. In addition, the funding levels for this project seem insufficient to truly test the accuracy and resolution of the sensing technologies over time. Notably, the project should make recommendations for standards/ assessments from baseline conditions—e.g., it does not propose or recommend methods to detect degradation.
- It is unknown whether or not this approach will result in a thorough assessment over time of the environmental impact of PV at the utility scale. This research will reduce the barriers to utility-scale PV, but it is unclear how this research will reduce balance-of-system soft costs, as these costs pertain to rooftop solar PV.
- The project is solely focused on federal agencies. There was no industry input while developing the tool and model. It is unclear how much collaboration with industry stakeholders will really be done. In general, the focus on adoption of the tool is unclear as there is no plan in place and it is uncertain where this really fits into the project development cycle.

## PROJECT: 27690 NATIONAL RENEWABLE ENERGY LABORATORY

### Water Use by PV Supply Chain

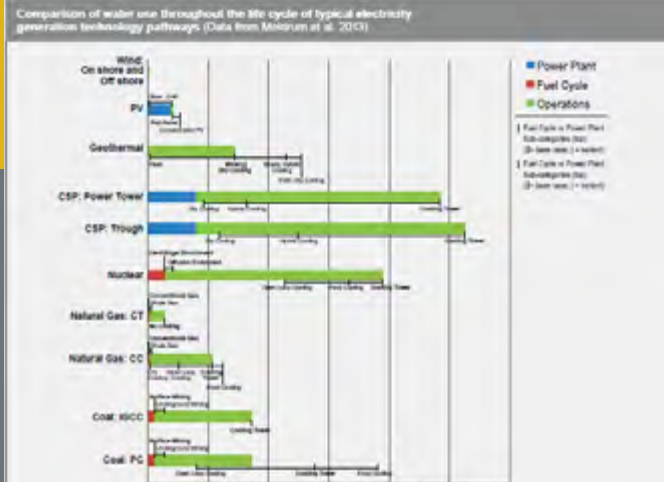

**FUNDING INFORMATION** \$0.35M | National Laboratory Research and Development | 10/2013–09/2014

### Project Description

The National Renewable Energy Laboratory (NREL) will build off the foundational work conducted in the SunShot Vision Study to provide a more comprehensive assessment of the water use benefits and tradeoffs associated with high penetration of solar power technologies. NREL proposes to fill gaps in the analysis of use and tradeoffs (economic and environmental) concerning photovoltaic (PV) water use relative to water use by other energy technologies. The results of this project will provide deliverables supporting the SunShot Initiative, as well as the United States' leadership of and contribution to the International Energy Agency (IEA) Implementing Agreement on Photovoltaic Power Systems Task 12 on Environmental Health and Safety.

### Individual Reviewer Comments

- This research is relevant in that it fulfills a task associated with the U.S. Department of Energy's involvement with IEA. The approach used in this research is solid. It is of interest to look at water use by the PV supply chain as it compares with other electric generation technologies. It was interesting to find out that San Antonio did not move forward with a PV manufacturing facility once water needs were identified for the facility.

- Water use is likely a comparative advantage of solar compared to other technologies. It is unclear how further documentation of this advantage will significantly contribute to SunShot goals. It may be as important to more accurately capture the water use of alternative technologies. Water impacts do need to be considered, but may not advance cost declines, nor hinder higher level of deployments.
- This is not relevant to soft-cost reduction. First off, the water problem is with concentrating solar power and this project is for PV. Second off, the manufacturing stage is not relevant since that's largely done in other places where water impact may not be a problem. However, having documented evidence that PV uses significantly less water than other generation sources can influence drought-prone areas' interest in installing. At the same time, the impact of this research on the deployment of PV in the United States is unclear.

## PROJECT: 27816 NATIONAL RENEWABLE ENERGY LABORATORY

### *Regulatory and Permitting Information Desktop (RAPID) Roadmap*



**FUNDING INFORMATION** \$0.50M | National Laboratory Research and Development | 12/2013–09/2014

### Project Description

This agreement at the National Renewable Energy Laboratory (NREL) is helping to optimize and streamline the regulatory process for utility-scale solar projects. Through the process of developing roadmap content, the project brings together both state and federal agencies, engaging them in reviewing and coordinating the permitting process for large solar photovoltaic (PV) developments and helping them reduce developers' costs and time for solar deployment. The Solar Regulatory Roadmap will build off the existing Geothermal Regulatory Roadmap for 10 Western states, which was developed by NREL in support of the U.S. Department of Energy's Geothermal Technologies Office, and has received overwhelming positive response from industry and agencies.

### Individual Reviewer Comments

- A strength of this award is the utilization of existing roadmapping for utility-scaled geothermal projects as a basis for roadmapping solar PV projects. The Regulatory and Permitting Information Desktop (RAPID) tool kit is relevant to both utility-scaled geothermal and PV. This tool kit will be helpful to PV project developers. The example flow charts, as part of the regulatory roadmap tool, will provide insights to the allocation of resources to achieve milestones.
- This is a valuable pathway identification effort that may reduce redundancy in utility permitting process. Working closely with permitting bodies and ensuring ongoing maintenance of information and contacts is a strength of the team.
- Overall funding seems low to support the goals and objectives of this project. Key strengths and unique features include the National Environmental Policy Act database and best practices. Based on other project reviews, the permitting atlas may be better developed/served under alternative efforts and grantees. Leveraging the successes of geothermal are promising; however, the researchers need to put more thought into the specific market barriers to the adoption of RAPID in the solar market and how the program will overcome these barriers to improve the use of RAPID in this adjacent (but unique) renewable category.
- A weakness of this award is that the geothermal model is utility scaled. The soft costs relate to rooftop PV and not utility-scale PV, so the relevancy of the RAPID tool kit to rooftop PV is unknown.
- Solar developer buy-in is unclear. The project team seems to have not thought through this step yet. In addition, the actual cost impact of efforts is unclear, and the strong focus on federal agencies may not be relevant for all utility solar projects.

## CONCLUSION

The SunShot Program Managers and DOE staff should be commended for their enthusiasm and efforts to drive down the cost of utility-scale solar electricity to \$0.06 per kWh by funding and overseeing the projects that private companies, universities, and national laboratories conducted in support of this goal.

On a 1 to 5 scale, with “1” being the lowest rating and “5” being the highest, the average score was 3.70, which indicates that most projects are meeting or exceeding expectations. Overall, the Steering Committee acknowledged that the SunShot project portfolio has achieved a good balance in funding projects across each program area, though more funding should be allocated to soft cost and public education activities as well as projects designed to improve the aesthetics of photovoltaic systems to increase their market appeal. Points that are worthy of note regarding the programs include:

- **Concentrating Solar Power:** Concentrating Solar Power projects are very strong, with an average overall project score of 3.74, which is higher than the SunShot project average. These projects are also on track for meeting the long-term goals of the program.
- **Photovoltaics:** 69 projects in this program were reviewed during the 2014 SunShot Peer Review. The collective overall average score for these projects is 3.47, which is lower than the cumulative average for SunShot projects. The lower score is attributed to a few poor-performing projects with large budgets that were providing value to neither the PV program nor SunShot. This can be rectified for future projects by developing strategies that apply evenly to projects to ensure that each project team is heading down a similar path to success.
- **Systems Integration:** Projects in this program are relevant, impactful, appropriately funded, and take a solid approach to meeting goals. The average overall project score is 4.19, which is significantly higher than the overall average in the entire Sun-

Shot portfolio. As opposed to other programs that were considered to be too broad, having a broad focus was one of this program’s strengths because it enabled multiple entities of varying backgrounds to work toward common goals.

- **Technology to Market:** In general, the outstanding projects in this portfolio are overshadowed by the underperforming projects—such as the consortia projects—which have brought down the overall average project score to 3.47. There are several projects that appear to be outside the scope of market activities. It would be more appropriate to cover these projects under an R&D program.
- **Balance of System:** Projects funded in this program have an average overall rating of 3.72, which is slightly above the overall average for SunShot-funded projects. This portfolio covers broad topic areas and could be more effective if projects, despite their diversity, worked toward similar goals and used more consistent strategies.

### Looking Forward

To continue to be successful going forward, the Steering Committee feels that the SunShot Initiative will need to strike a balance between projects that have small improvements over time and capital-intensive projects whose desired results will take years to come to fruition. It will also be helpful during the FOA process to make cost reduction a goal of each project that is submitted for funding so that it may ensure that potential Primary Investigators are thinking about the overarching \$0.06 per kWh goal, or ancillary goals—such as a renewable penetration—even before their project is selected for inclusion in the program. In addition, SunShot should place some emphasis on innovation in manufacturing equipment as a means to potentially attract a U.S. PV manufacturing base. A near-term goal should also be to host a workshop on reliability that focuses on pre-competitive issues and results in the development of reliability and durability standards. Even developing a renewable roadmap that includes cost and penetration goals would help SunShot move forward.

\* Please note that Steering Committee recommendations are for advisory purposes only and do not impact current or future funding decisions.

In terms of the technology areas, reviewers feel that there were many ways in which they could continue to be successful, if not more successful, in the future. Recommendations by technology area include:

- **Concentrating Solar Power:** Going forward, more coordination between groups working on similar technologies or types of projects would help the Concentrating Solar Power program be more successful. The program will also benefit by including more projects focused on cleaning equipment, land preparation, power and networking, component and subcomponent design, systems integration, and part and sub-system standardization.
- **Photovoltaics:** As a whole, more industry involvement, collaboration between universities and institutions, focus on processes, and a modified approach to CIGS will help make this portfolio stronger. New technologies and packaging, improved panel reliability, and the development of analytic tools will help establish the foundation for breakthroughs. A consideration of post-doctoral candidates from outside of the United States would also be beneficial and may ensure that the best qualified people are awarded funding to work on DOE projects.
- **Systems Integration:** This high-performing program may be strengthened through more analysis projects (e.g., adding energy storage to solar facilities and the electric grid), an understanding

of transmission operations and how to seamlessly increase PV generation, and a value proposition assessment of the full spectrum of PV system services and benefits.

- **Technology to Market:** Focusing more on economic analysis activities, PV system performance, inverter and energy storage technology development, and business development activities could help the portfolio have a larger impact. Having a clear link to the market would also be helpful, as many projects seem to be more appropriate for programs that focus on research and development. One potential avenue for addressing this is through consultation with venture capitalists when preparing a FOA to ensure that the market component and business development are adequately addressed in the solicitation.
- **Balance of System:** A clear strategy that explains how soft costs can be reduced will help strengthen this program in the future. Projects can also use it for benchmarking, fulfilling objectives, reaching milestones, and specifying outcomes. Additionally, projects that have a utility component need to focus on making partnerships more encompassing, such as having greater involvement with education and information.

Together, these recommendations for each program and project portfolio will help SunShot continue down its successful path and ultimately fulfill its goals in the future.

## APPENDIX A: SUNSHOT INITIATIVE STAFF

Table 13: SunShot Initiative Staff during the 2014 Peer Review

Team Member		Title	Group
<b>Minh</b>	<b>Le</b>	<b>Director</b>	<b>Director</b>
Stephanie	Abraham	Administrative Assistant	Operations
Vanina	Alanes	Financial Analyst	Financial
Monica	Andrews	SETA	BOS/T2M
David	Arfin	Consultant	BOS
Shubhra	Bansal	SETA	PV
Venkat	Banunarayanan	SETA	SI
Christine	Bing	Technical Project Officer	CSP
Diana	Bobo	CO/ Grants Management Specialist	OAFA
Daniel	Boff	SETA	BOS
Michael	Bolen	SETA	T2M
Anna	Brockway	SunShot Fellow	BOS
Michael	Cliggett	Technology Manager	SI
Adam	Cohen	AAAS Fellow	BOS
Craig	Connelly	Management & Program Analyst	Special Projects
Michael	Contreras	AAAS Fellow	BOS
Steven	Cornish	Financial Analyst	Financial
Glen	Drysdale	Attorney Adviser	Legal
David	Feldman	Senior Technology & Financial Analyst	NREL
Steve	Gardner	Financial Analyst	Financial
Michael	Goldstone	Attorney Adviser	Legal
Doug	Hall	Technology Manager	T2M
Edward	Hoegg	SunShot Fellow	CSP
Rose Marie	Holsing	Technical Project Officer	BOS
Susan	Huang	SETA	PV
Joshua	Huneycutt	Technology Manager	BOS
Levi	Irwin	SETA	CSP
Becca	Jones-Albertus	Program Manager	PV
Victor	Kane	Technology Manager	T2M
Kelly	Knutsen	Technology Manager	BOS
Olayinka	Kolawole	Technology Manager	BOS

**Table 13: SunShot Initiative Staff during the 2014 Peer Review**

	<b>Team Member</b>	<b>Title</b>	<b>Group</b>
Mark	Lausten	SETA	CSP
Pamela	Lavergne	Cost-Price Analyst	OAFa
Marie	Mapes	Technology Manager	PV
Robert	Margolis	Senior Technology & Financial Analyst	NREL
David	Mayorga	Communications	Communications
Jacob	Mees	Financial Analyst	Financial
Jeremy	Mikrut	Grants Management Specialist	OAFa
Scott	Morgan	SETA	T2M
Christina	Nichols	SETA	BOS
Garrett	Nilsen	SETA	T2M
Jamie	Nolan	Communications	Communications
Allison	Pezzullo	Administrative Assistant	Operations
Candace	Pfefferkorn	AAAS Fellow	CSP
Clay	Pfrangle	CO/ Grants Management Specialist	OAFa
Christian	Philipsen	Financial Analyst	Financial
Ranga	Pitchumani	Program Manager	CSP/SI
Andru	Prescod	SETA	CSP
Ammar	Qusaibaty	SETA	BOS
Alvin	Razon	SETA	SI
Tommy	Rueckert	Technical Project Officer	CSP
Michael	Schledorn	Solar Branch Chief	OAFa
Lidija	Sekaric	Program Manager	T2M
Samantha	Shiffman	Administrative Assistant	Operations
Avi	Shultz	SunShot Fellow	CSP
Jeannette	Singsen	CO/ Grants Management Specialist	OAFa
Daniel	Stricker	Technical Project Officer	T2M
Lenny	Tinker	Technology Manager	PV
Uriel	Trujillo	CO/ Grants Management Specialist	OAFa
Elaine	Ulrich	Program Manager	BOS
Ebony	Vauss	Operations Supervisor	Operations
Guohui	Yuan	SETA	SI



## APPENDIX B: LIST OF ACRONYMS

Table 14: List of Acronyms used in the Report

Acronym	Full Name
AHJ	Authority Having Jurisdiction
ANL	Argonne National Laboratory
BOS	Balance of Systems
CIGS	Copper indium gallium selenide
CPV	Concentrated Photovoltaics
CSP	Concentrated Solar Power
DOE	U.S. Department of Energy
EIA	U.S. Energy Information Administration
F-PACE	Foundational Program to Advance Cell Efficiency
HCPV	High Concentrated Photovoltaic
HTF	Heat Transfer Fluid
HVM	High Volume Manufacturing
HVPE	Hydride vapour phase epitaxy
ICMA	International City/County Management Association
IREC	Interstate Renewable Energy Council
ISFH	Institute for Solar Energy Research Hamelin
ISO	International Organization for Standardization
LBNL	Lawrence Berkeley National Laboratory
LCOE	Levelized Cost of Energy
MOCVD	Metalorganic vapour phase epitaxy
MOVPE	Metalorganic vapour phase epitaxy
MURI	Multidisciplinary University Research Initiative
NREL	National Renewable Energy Laboratory
O&M	Operations and Maintenance
OAFA	Office of Acquisitions and Financial Assistance
SETA	Science and Engineering Technology Advisor

## APPENDIX C: ENDNOTES

- <sup>1</sup> U.S. Department of Energy, Office of Energy Efficiency and Renewable Energy. Peer Review Guide. Aug. 2004, p. v. See: <http://energy.gov/sites/prod/files/2013/11/f5/2004peerreviewguide.pdf>.
- <sup>2</sup> National Renewable Energy Lab and U.S. Department of Energy. SunShot Vision Study. Feb. 2012. pp.4–5. See: <http://energy.gov/eere/sunshot/sunshot-vision-study>.
- <sup>3</sup> Ibid.
- <sup>4</sup> See: <http://www.seia.org/blog/seia-turns-40-shout-out-solar>.
- <sup>5</sup> Ibid.
- <sup>6</sup> National Renewable Energy Laboratory. Dec. 2013. See: <http://www.nrel.gov/news/press/2013/5306.html>.
- <sup>7</sup> National Renewable Energy Laboratory and U.S. Department of Energy. SunShot Vision Study. Feb. 2012. p.7. See: <http://energy.gov/eere/sunshot/sunshot-vision-study>.
- <sup>8</sup> U.S. Department of Energy. Feb. 2014. See: <http://www.energy.gov/articles/us-utility-scale-solar-60-percent-towards-cost-competition-goal>.
- <sup>9</sup> National Renewable Energy Laboratory. Internal Cost Model. Nov. 2013.
- <sup>10</sup> U.S. Department of Energy. Feb. 2014. See: <http://www.energy.gov/articles/us-utility-scale-solar-60-percent-towards-cost-competition-goal>.
- <sup>11</sup> Based on electricity consumption data for 2012.





DOE/EE-1129  
August 2014