

Development of an Airless Thermal Enhancer to Allow Catalyst Function on Cold Temperature Cycles



Objective: Develop an exhaust heater suitable for in exhaust use for

- Improving catalyst function during cold cycles
- Ensuring reliable filter regeneration when used with HC dosing

Nik Birkby; Steven Beesley; Mark Ramsbottom &
Navin Khadiya

EMCON Technologies

Development of an Airless Thermal Enhancer to Allow Catalyst P3 Function on Cold Temperature Cycles

Benefits

- Eliminates the need for engine based thermal management improving fuel economy
- Improves engine durability particularly when using Bio Diesel
- Rapid heating of DOC (≈ 15 seconds)
- Helps reduce PGM and potentially the size of the aftertreatment system
- No combustion air is required
- Proven components
- Small package claim
- Cost effective

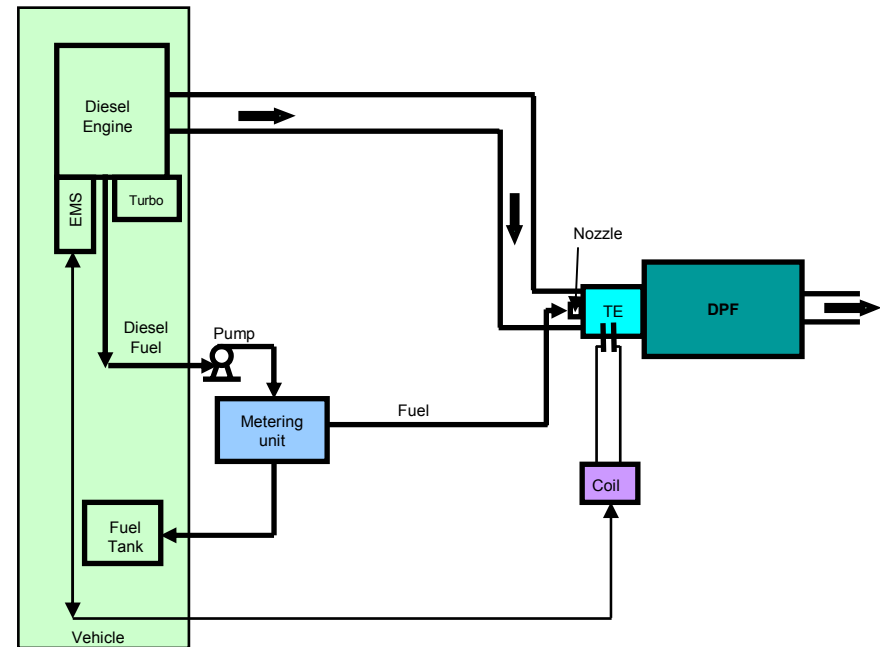

Development of Thermal Enhancer 350°C Target

