

**DISTRIBUTED ENERGY PROGRAM REPORT**

# Distributed Energy Technology Characterization

January 2004

By

Energy and Environmental Analysis, Inc.



**U.S. Department of Energy**  
**Energy Efficiency  
and Renewable Energy**

Bringing you a prosperous future where energy  
is clean, abundant, reliable, and affordable





## TABLE OF CONTENTS

1.	INTRODUCTION .....	1
2.	DESICCANT APPLICATIONS .....	2
	<i>Application Requirements Favoring Desiccants</i> .....	2
	<i>Evolution of the Desiccant Market</i> .....	2
	<i>Industrial Process or Storage</i> .....	3
	<i>Cold Footprint Buildings</i> .....	4
	<i>Comfort/IAQ Applications</i> .....	4
3.	TECHNOLOGY DESCRIPTION .....	6
4.	SYSTEM COST AND PERFORMANCE CHARACTERISTICS.....	14
5.	DESICCANT INTEGRATION WITH CHP .....	20
	5.1 <i>Direct Exhaust Systems</i> .....	20
	5.2 <i>High Temperature Desiccant Reactivation System</i> .....	21
	5.3 <i>Low Temperature Heat Recovery with Supplemental Firing</i> .....	22
	5.4 <i>Low Temperature Reactivation System</i> .....	23
	5.5 <i>Summary of Heat Recovery Options for Solid Desiccant Systems</i> .....	25
6.	ADVANCED TECHNOLOGY PROJECTIONS .....	30
7.	CONCLUSIONS .....	35
	<i>Applications</i> .....	35
	<i>Desiccant System Cost and Performance</i> .....	36
	<i>Technology Advances</i> .....	37
	<i>Technical Integration Potential with CHP</i> .....	37
	<i>Economic Issues/Market Potential</i> .....	38
	<b>APPENDIX A: PSYCHROMETRIC CHART EXPLANATION.....</b>	<b>1</b>



## **Abstract**

The purpose of this report is to characterize desiccant technology and applications, and to show how these technologies can be designed to utilize the available thermal energy from a combined heat and power (CHP) system. This technology characterization is intended to provide decision-makers and system developers with information on appropriate applications, basic system design and sizing principles, and cost and performance of desiccant systems alone and as part of an integrated energy system (IES).

This report finds that while desiccants currently have applications where protection of product value is the overriding concern, such as industrial processes, warehousing, cargo, and cold footprint buildings, there is also an emerging market for desiccants in controlling humidity for comfort and indoor air quality in a range of commercial buildings. It is found that desiccant systems can reduce the electric cooling load on many application sites, achieving a benefit in both capacity and energy reduction, which can offset about 40-60% of the capital cost of installing a compound desiccant system. However, the report concludes that in order to break out of existing niche markets, desiccant systems need to be made less costly; specifically reactivation and fan energies need to be reduced.

Several conclusions are drawn regarding desiccant integration with CHP. The aspects of integration analyzed include overall sizing, temperature range, heat recover/delivery technology, physical integration issues, annual energy consumption, and advanced desiccant technology. With regard to the economic issues of integration, the report concludes that when one system is only marginally economic, the other must be economic in order for an integrated system to be economic. Integration will allow these systems' market niches to immediately expand, particularly in the case of CHP systems in commercial buildings with limited loads but large HVAC loads that could be taken over by thermally activated technologies (TATs). Finally, the report concludes that the current formula for measurement of CHP efficiency does not take into account the efficiency of the TAT to which it is matched, and public policy should be carefully designed so as not to discourage this integration.



## 1. Introduction

Desiccants are a class of materials that have a high affinity for moisture. Many materials are capable of absorbing moisture from the air such as nylon, wallboard, and paper. However, desiccants are capable of absorbing (or adsorbing) much greater quantities of moisture, from 10 to 10,000 times their dry weight in water vapor. The surface water vapor pressure of desiccant materials is very low. Desiccants will absorb moisture until the vapor pressure between the desiccant and the air stream is equalized. As the desiccant absorbs moisture, the heat of condensation of the vapor heats the material. At higher temperatures, the surface vapor pressure of the desiccant rises and no more vapor can be removed from the air. If a desiccant is then removed from the process air stream and heated to 200° to 300° F, its vapor pressure rises above the surrounding air and the moisture is released into the exhaust air stream. When this hot dry desiccant material is cooled, it will once again be capable of absorbing moisture from the air. Three steps, *sorption*, *desorption*, and *cooling* form the basis of a reversible thermally activated solid desiccant cycle that can provide dehumidification of air or dehydration of other gases.

Using heat as a driver, desiccant cycles are classified as a *thermally activated technology* (TAT). This thermal energy can come from direct combustion of a clean fuel, or from hot water or steam. The purpose of this report is to characterize desiccant technology and applications, and to show how these technologies can be designed to utilize the available thermal energy from a combined heat and power (CHP) system. This technology characterization is intended to provide decision-makers and system developers with information on appropriate applications, basic system design and sizing principles, and cost and performance of desiccant systems alone and as part of an *integrated energy system* (IES).

The report is organized into the following sections:

1. **Desiccant Applications** – General applications requirements and specific applications that favor desiccant systems are presented.
2. **Technology Description** – Basic operating principles are presented, alternative system components and alternative technologies are described.
3. **System Cost and Performance Characteristics** – Based on a set of example applications, desiccant and desiccant based IES system cost and performance is defined.
4. **Advanced Technology Projections** – Key technology advances are discussed and a forecast of future desiccant and desiccant based IES system cost and performance is presented.
5. **Conclusions** – A summary of key results is presented along with an overall assessment of the benefits and barriers of combining desiccant systems into an IES.

## 2. Desiccant Applications

This section describes the general application requirements that can provide an economic benefit for the use of desiccant systems and specific applications where desiccants have been used traditionally or are being targeted.<sup>1</sup>

### *Application Requirements Favoring Desiccants*

There are several factors that determine whether or not desiccant dehumidification systems can add value to a system installation compared with conventional vapor compression air conditioners and refrigeration equipment.

1. **Economic Benefit for Low Humidity** – Operation of the facility is enhanced by humidity reduction or maintenance of a very-low dew point. Some examples are industrial processes such as candy and pharmaceuticals production, where maintaining proper humidity is important for maintaining production rates, reducing scrap, and improving product quality.
2. **High Moisture Loads** – High moisture loads can be caused by high concentrations of people (theaters, schools, retail, restaurants), by swimming pools and spas, by humid weather conditions, or by refrigeration loads (supermarkets, ice rinks) that remove sensible heat and leave behind the moisture loads. When the sensible heat ratio (sensible heat load/total heat load) (SHR) falls below 0.7, conventional HVAC equipment cannot remove the moisture without overcooling the space and requiring reheat.
3. **High Ventilation Requirements** – Buildings that require a higher percentage of fresh air increase the moisture load for the conditioned space, thereby decreasing the SHR. This factor is measured by the percentage of fresh air required. In applications that require more than 15% fresh air, a desiccant system can often improve the overall economics of the application.
4. **Availability of Exhaust Air** – In applications where conditioned air is collected by ducts and returned to the HVAC system or exhausted from the building, a desiccant system can be used to recover energy.
5. **Large Spark Spread** – Applications with high electric costs and low steam or natural gas costs can cost effectively shift load from the HVAC system to the desiccant system.
6. **Economic Benefit for Dry Duct-work** – When a conventional HVAC system is used to remove moisture, this moisture collects on the evaporator coils and in the ductwork. This moisture can breed bacteria, mold and other airborne pathogens. In hospitals, hotels, and even in some office buildings it is important to remove this potential source of contamination from the indoor air environment.

### *Evolution of the Desiccant Market*

Desiccant dehumidification systems have been used since the 1920s in high-value industrial applications (candies, batteries, and pharmaceuticals), military storage, and marine transportation of moisture sensitive products such as leather goods and electronic equipment. In the 1980s, desiccant systems were developed for supermarket use. Today there are over 1,000 such systems

---

<sup>1</sup> Unless otherwise noted, the material in this section is taken from *Desiccant Technology Transfer Workshop Version 1.0*, an interactive software training-tool developed by the American Gas Cooling Center. Information in the software was in some cases clarified by means of personal communications with Douglas Kosar, Principal Research Engineer, Energy Resources Center, University of Illinois at Chicago.



in operation, and about half of the national supermarket chains specify desiccant systems in new construction. In the 1990s, desiccants began to appear in broader commercial markets. One of the reasons for this trend was the requirement in many building codes to increase the fresh air supplied to the conditioned space. This requirement is based on ASHRAE Standard 62-89 that increases minimum fresh air requirements in many applications by a factor of three to four. These changes are viewed as necessary to maintain indoor air quality. However, in many climates such an increase in ventilation requirements puts a strain on conventional HVAC equipment that was not designed for the high rates of moisture removal. Another requirement of ASHRAE 62-89 was to require that the humidity levels inside the HVAC ductwork be kept at 70% relative humidity (RH) or below. These changes acted to lower the SHR of the applications, making desiccant dehumidification economic for certain comfort/IAQ applications.

The current markets for desiccant systems can be broken down into three categories:

1. Industrial Process or Storage – pharmaceuticals and other chemicals, processed foods, electronics, and military storage
2. Cold Footprint Buildings – supermarkets, ice rinks, and refrigerated warehouses
3. Comfort/Indoor Air Quality – hospitals, nursing homes, hotels, theaters, schools, restaurants, and retail stores.

### ***Industrial Process or Storage***

The primary advantage of a desiccant system is its ability to control moisture. The equipment first cost can be justified by increases in product throughput and reduced waste.

- **Corrosion Protection-** Corrosion protection is important in military storage, lithium battery production, power plant lay-up, and electronics storage. A RH of less than 35% is required in these applications. In addition, in most of these applications, temperature control is not important so a desiccant system can be used alone to provide the necessary moisture control. Desiccant systems for industrial applications are designed for severe duty. They typically have a high first cost, and they may use an electric heater to provide the regeneration heat.
- **Mold and Fungus Growth Protection-** Another sub-market is *mold and fungus growth protection*. Such protection requires an RH of between 40-60% and is often required in marine transportation, archival storage, seed storage, and breweries.
- **Moisture Regain Prevention-** A number of production processes involving moisture sensitive products such as candy packaging, pharmaceuticals, glass laminating, and composite manufacturing require moisture regain prevention. Humidity control allows higher production rates, reduces product scrap, and improves product quality. The control technique is generally to modify the RH of the production areas to the same vapor pressures exhibited by the desired moisture level in the product.
- **Product Drying-** As in moisture regain prevention; drying applications are designed such that the RH of the air is maintained at the desired moisture level of the dried product. Examples of drying applications are the investment casting industry, candy coating, plastic resin drying, and cereal drying.

### ***Cold Footprint Buildings***

Cold footprint buildings have unique space conditioning requirements resulting from the presence of large refrigeration loads. The primary markets in this category are refrigerated warehouses, supermarkets, and ice rinks.

- **Refrigerated Warehouses** – Cold air can lead to ice build-up and slippery conditions on loading docks and also to frost buildup on product and evaporator coils. Desiccant systems are being used to dry the air in the loading dock area and direct dry air across the warehouse doors.
- **Supermarkets** – The refrigerated display cases in supermarkets contribute to cold aisles in the store, high humidity can cause frost to build-up on products in the display cases and on the evaporator coils. A conventional HVAC system cannot provide the dehumidification necessary without the use of reheat. Desiccants can provide independent dehumidification leading to a reduction in space conditioning loads, a reduction in refrigeration energy use, and a more comfortable store environment for shoppers.
- **Ice Rinks** – Common problems in ice rinks are fog, water puddles, frequent need to resurface, high refrigeration costs, and spectator discomfort. Because the large ice sheet provides a great deal of sensible cooling to the space, the SHR for the building is very low and it is desirable to maintain a low dewpoint for the air inside the rink. These two factors contribute to an ideal application for desiccant assisted space conditioning. Because of the high degree of sensible cooling provided by the ice sheet, ice rink desiccant systems are often single-wheel designs with no post cooling or heat exchange provided to the warm dry air exiting the desiccant.

### ***Comfort/IAQ Applications***

Industrial and cold footprint applications are well-established markets for desiccant systems. An emerging market is in comfort conditioning applications that require high ventilation rates and/or have particular indoor air quality requirements. Indoor air quality is a function of two interrelated factors: ventilation rate and moisture control. However, increasing ventilation also increases moisture loads. A number of commercial applications with high ventilation requirements and critical indoor air quality issues have benefited by the use of a desiccant system for independent control of temperature and humidity in the conditioned space.

- **Hospitals** – The control of airborne pathogens is critical for hospitals. Dry ductwork is essential to reducing bacteria and mold formation. In addition, operating rooms require special air handling systems to maintain cool, dry conditions both for the comfort of the operating team, but also for the health of the patient. Desiccants, especially liquid desiccant systems can also act directly as filters, removing airborne contaminants from the process air.
- **Schools** – High occupancy increases ventilation requirements and latent load. In addition, children are more sensitive than adults to allergens and other airborne contaminants, making indoor air quality a priority for schools. Recommended ventilation levels are 15 cfm/student or about 450 cfm/classroom. Recommended indoor relative humidity levels should be maintained between 40-60%. Desiccant systems can be combined with conventional space conditioning systems or integrated systems can be used.

- **Hotels** – The American Hotel and Motel Association reported that they spend about \$90 million per year addressing mold and mildew damage. Some hotel chains in humid climates are finding that they can reduce both operating costs and also redecorating costs by reducing moisture loads in the hotel space by using desiccant systems.
- **Restaurants** – Restaurants are a high occupancy application, and they have high exhaust requirements for the cooking areas that must be made up with ventilation air. In addition, indoor air conditions must satisfy people at very different activity levels – from diners (stationary) to waiters (active) to the kitchen staff (very active.) Desiccant systems can be used to balance these competing requirements.
- **Theaters** – High occupancy rates, presence of sound (and moisture absorbing) insulation materials, lack of window and light loads, and typical evening occupancy patterns, during periods of low dry bulb and high wet bulb conditions, make moisture control very important for occupant comfort. A multiplex requires approximately 1,500 cfm of ventilation air per screen. In humid climates, desiccants can be used effectively to provide lower cost space conditioning and better comfort.

The applications listed above will be particularly attractive for desiccant systems in regions with low SHR, i.e., regions where latent load is high relative to sensible load. **Figure 1** shows the ratio of sensible to latent cooling loads in a number of cities across the U.S. Latent dehumidification loads resulting from ventilation air are much larger than sensible cooling loads throughout the Southeast, East South Central, East North Central, and Middle Atlantic States. A majority of the population and business activity in the country is in these regions.

All of these applications with the possible exception of schools are service industries where customer comfort is an important economic parameter. Among these applications, hospitals, hotels, and schools already represent historically good markets for CHP. Combining the benefits of desiccant systems into an IES could expand the potential market for CHP. Restaurants could represent a potential market for smaller IES systems. Theaters, due to their intermittent loads, might not represent the best opportunity for integrating a desiccant system with CHP.

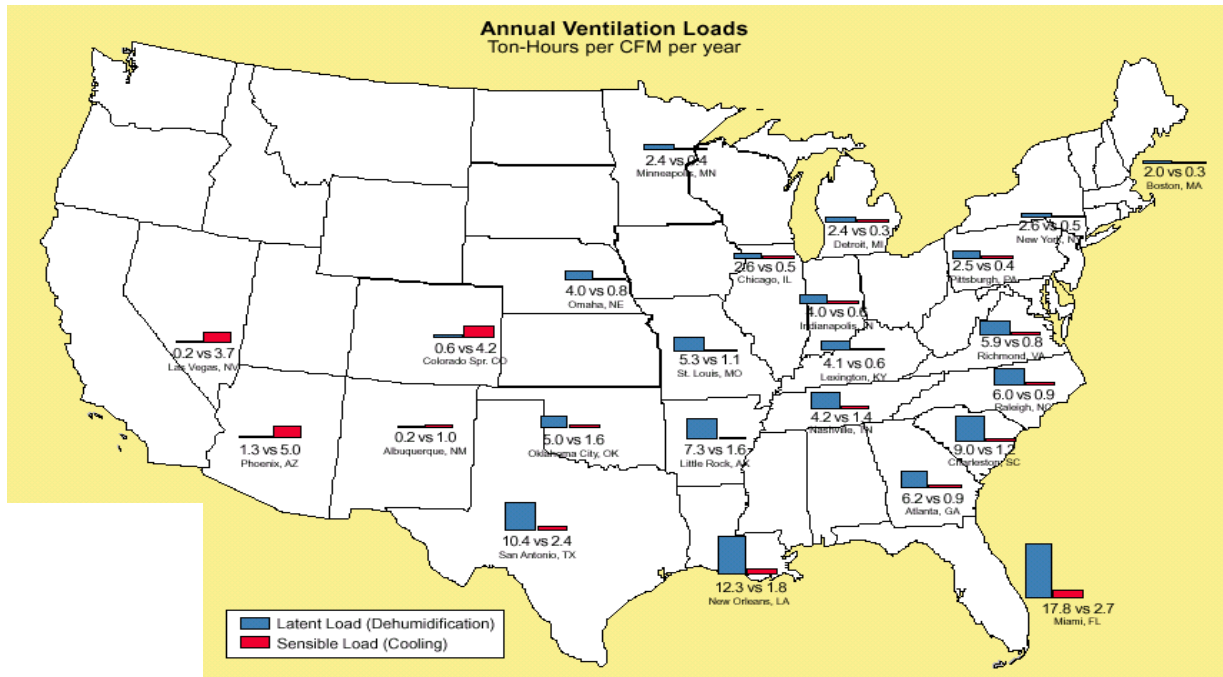

Source: Lewis G. Harriman III, et al., "Dehumidification and Cooling Loads from Ventilation Air," *ASHRAE Journal*, November 1997.

**Figure 1. Map of Ventilation Load Indexes for Selected Locations**

### 3. Technology Description

Desiccant systems can be configured in a variety of ways depending on the needs of the application. At the heart of the system is the desiccant component itself. Moist air is dried by passing it over or through the desiccant material. The desiccant is subsequently *reactivated* by driving off the acquired moisture with heated air that is then exhausted. There are a variety of methods to bring the desiccant material into contact with the process air stream: twin solid packed beds, liquid spray tower, wicked surface contact, or rotating wheel:

- In a packed bed air is passed across a packed desiccant bed where moisture is adsorbed. When the bed reaches saturation, the air stream is diverted to a second desiccant bed while the first is reactivated with heated air. This type of system is rarely used in space conditioning applications because there is a significant pressure drop across the fixed bed.
- In a liquid spray tower, a spray of concentrated aqueous desiccant solution washes the process air. The process air is simultaneously dried and cooled in this step. The now dilute desiccant solution is pumped to a regenerator where it is heated to drive off the excess water.

- A desiccant wheel consists of a (ceramic, aluminum, or polymer) substrate, resembling corrugated cardboard that is rolled up into a wheel creating a very high surface area with myriad air channels parallel to the direction of airflow. This substrate is coated with desiccant material. Airflow across the wheel is divided into two separate sections. In the process section, the process air is dried. In the reactivation section, hot air is passed across the desiccant to drive off the moisture. The wheel rotates slowly creating a continuous process of adsorption and reactivation.

Heat is required for reactivation no matter what the configuration of the desiccant system. A solid desiccant wheel needs heat approximately in the range of 150-350° F. This hot air is supplied by an electric heater, direct gas burner, indirect gas burner, hot water loop, or steam loop. The electric option is used only in smaller industrial processes, as the use of an electric resistance heater is never economic in a space conditioning application. It is the reactivation requirement that creates the integration potential with CHP. The CHP system heat can be delivered to the desiccant process either through a hot water or steam heat recovery system or, for some technologies like microturbines, by using the direct exhaust from the prime mover. These options will be described further in *Section 4*.

By itself, a desiccant wheel provides hot, dry air. In certain industrial applications, where temperature control is not needed, a desiccant wheel is all that is used. In space conditioning systems, however, the heat added by the adsorption process is removed by one or more pre-cooling or post-cooling options. Heat exchangers (sensible heat wheel or heat pipe) can remove heat from the process air stream and simultaneously heat up the reactivation air prior to passing across the reactivation heater. Either direct or indirect evaporative cooling systems can be used on one or both sides of the system. A system with these components can be designed to accomplish 100% of the cooling load in certain applications. Such systems were developed in the 1980s and 1990s but have generally proved too costly for commercial application. More common, is to include electric air conditioning to complete the system. These systems are called *hybrid* systems. The advantage of hybrid systems is that the residual air conditioning load is much smaller than the total load, and the operating conditions (sensible cooling only) create an opportunity to increase the coefficient of performance (COP) of the cooling equipment, further reducing electricity consumption.

**Figure 2** shows a schematic for a two-wheel desiccant dehumidification system with post-cooling.<sup>2</sup>

1. Outside air at 85° F and 120 gr/lb of moisture (66%RH, 76° WB) (A) is passed across the desiccant wheel
2. The process air is heated and dried (145°, 50 gr/lb, 5% RH, 80° WB) (B)
3. A sensible heat wheel or heat pipe transfers heat from the process air stream to the reactivation air stream, simultaneously reducing the cooling load and the reactivation energy required. Using outside air for reactivation, this heat exchange reduces the temperature of the process air [C] to 100°, 50 gr/lb (17% RH, 68° WB.) If building exhaust air were used instead as the source of the reactivation air-stream, this temperature could be reduced even further.

<sup>2</sup> Private communication, John Fischer, Chief Technology Officer, SEMCO, Inc., October 14, 2004.

4. Either a direct expansion air conditioner or chiller coil is used to reduce the process air to space neutral supply conditions [D] 76°, 50 gr/lb (37% RH, 60° WB.).
5. On the reactivation side, the heater raises the temperature of the reactivation air to about 250° and the moisture is driven off the desiccant wheel to complete the process.

These temperature and humidity flows are plotted on a *psychrometric chart*<sup>3</sup>, **Figure 3**. The chart provides a convenient representation of the airflow conditions and the air conditioning load. The solid (red) line represents the temperature and humidity characteristics of the process air stream corresponding to the lettered points on the schematic (Figure 2.) The dashed (blue) line represents the corresponding changes if the entire cooling load were met by an electric air conditioner that first cooled, dehumidified, and partially reheated the air. In the desiccant case, as previously described outside air [A] is dried by the desiccant [B], then cooled in a heat exchanger with more outside air [C], and finally the dry, warm air is cooled to the delivery specifications by an electric air conditioner [D]. Assuming airflow of 12,000 cfm, the load on the electric air conditioner is 80 tons. With the hybrid desiccant system, the electric portion of the cooling load is reduced to 50 tons – a 40% reduction. The remainder of the load is met by the thermally activated technology.

An alternative to the two wheel desiccant system with post cooling is to use a rooftop air conditioner for precooling. Industry and Oak Ridge National Laboratory are developing this approach cooperatively.<sup>4</sup> Using the combined package to condition makeup air, the approach requires a much smaller desiccant wheel than that required for the post cooling system. The system is smaller which translates into lower cost and is better integrated with the conventional air conditioning equipment. Overall energy consumption is reduced, and the regeneration temperature required is significantly lower than in the post cooling system shown in Figures 2 and 3. Regeneration temperature is an important consideration when matching a desiccant system to recovered thermal energy from an integrated energy system. **Figure 4** shows a schematic representation of the system. Outside air is treated by the rooftop HVAC unit and then a portion of the air (half in this example) is deeply dried by the desiccant wheel. This heated and deeply dried air is then remixed with the remaining output from the HVAC unit producing a dry, neutral temperature air stream. In applications with very low SHR, this configuration avoids oversizing of the conventional, vapor-compression system to deal with the latent load (dehumidification) and requirement for reheat. **Figure 5** shows the corresponding psychrometric chart for this example. The air-streams are identified by letter (see Figure 4.)

<sup>3</sup> An explanation of the psychrometric chart is provided in Appendix A.

<sup>4</sup> James R. Sand and John C Fischer, “Active Desiccant Integration with Packaged Rooftop HVAC Equipment,” Oak Ridge National Laboratory and SEMCO Incorporated, 2003 International Congress of Refrigeration, Washington, D.C., August 17-22, 2003.

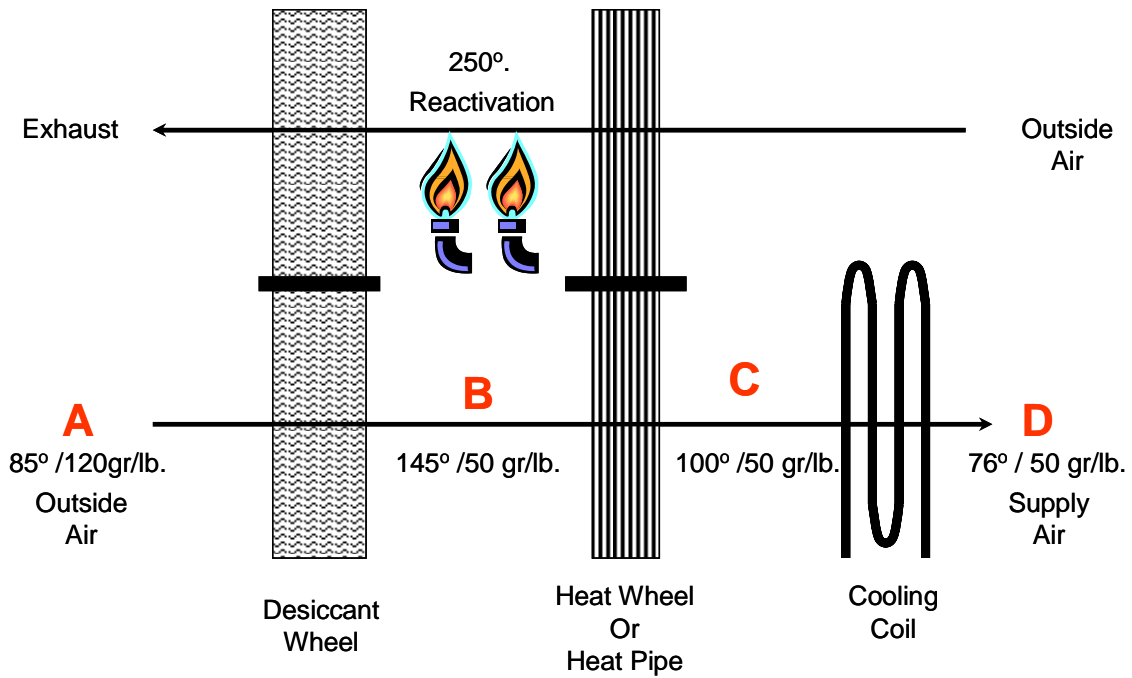

Figure 2. Two Wheel Desiccant Dehumidification and Cooling System

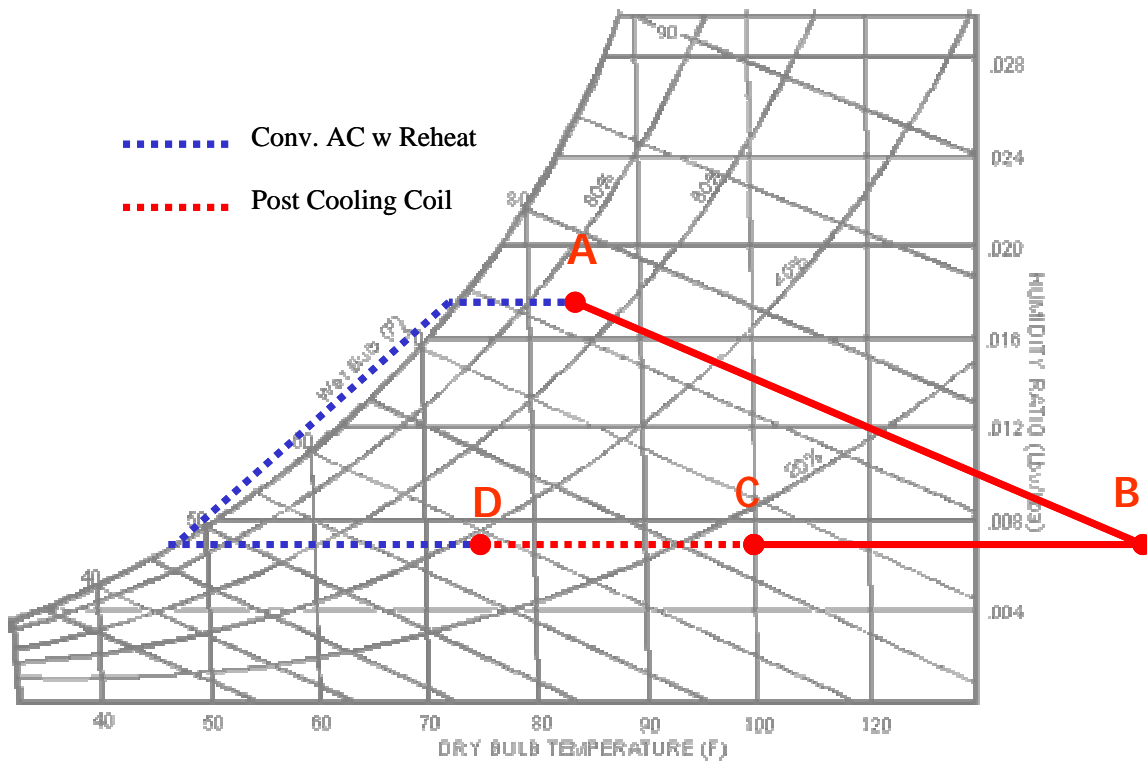

Figure 3. Temperature and Humidity Changes in the Two Wheel Desiccant Dehumidification System

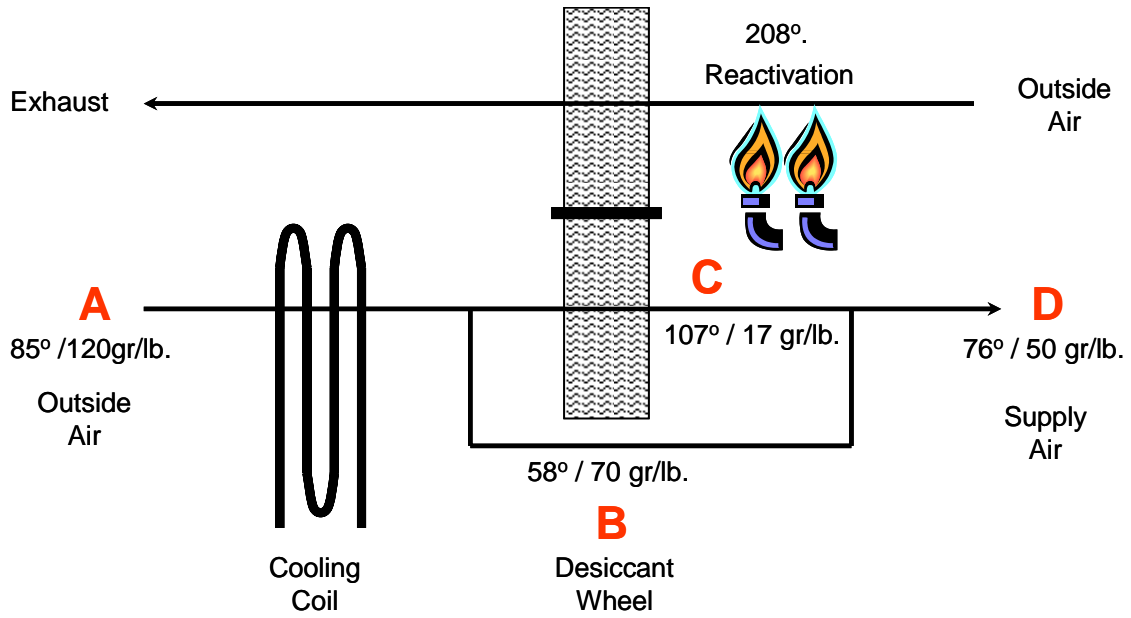

Figure 4. Active Desiccant Module with Precooling

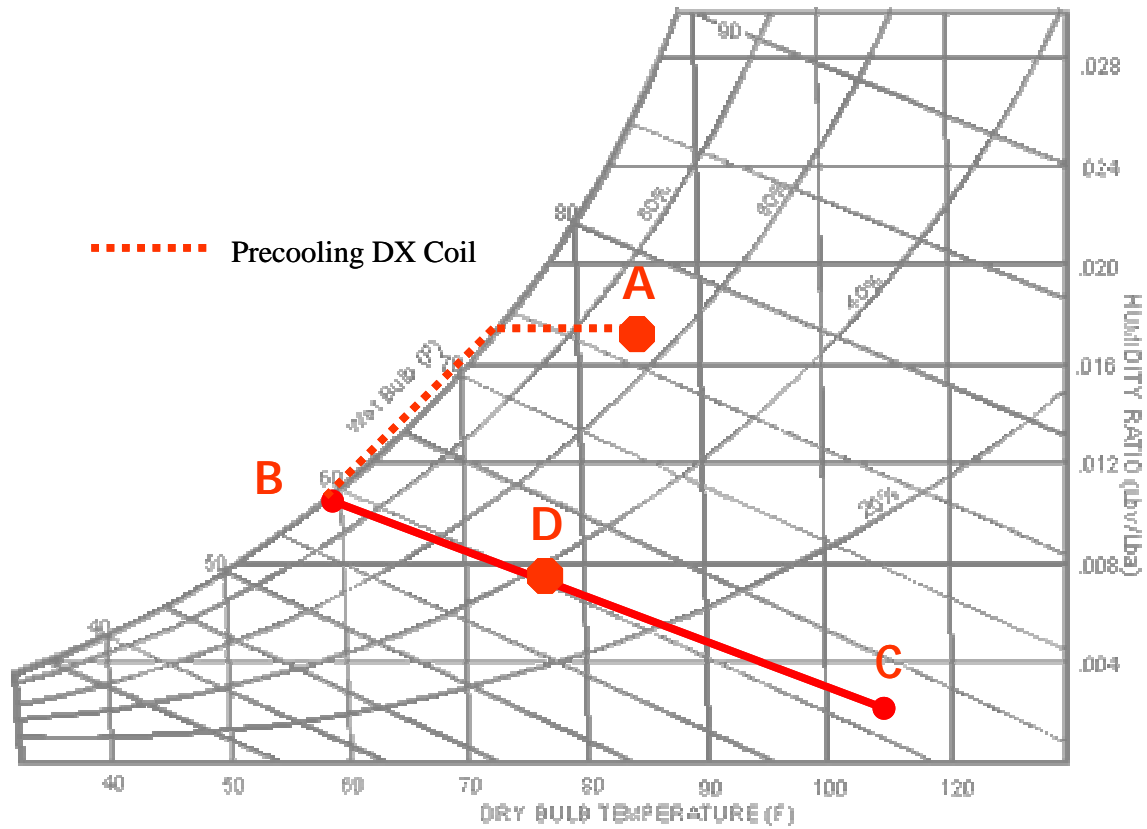
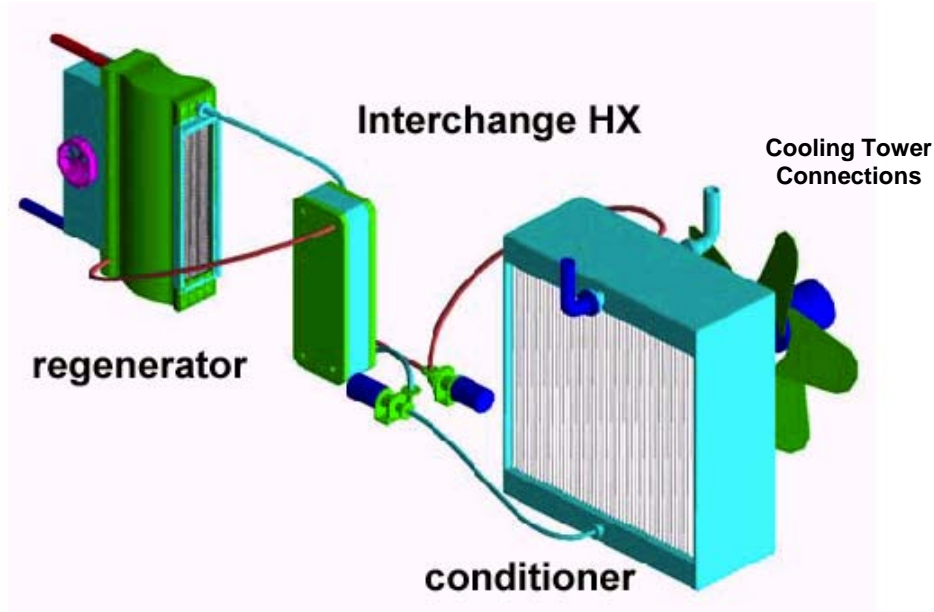

Figure 5. Temperature and Humidity Changes in the Precooling Configuration



Liquid desiccant systems are also available for dehumidification and comfort conditioning applications. A liquid desiccant system uses an open absorption cycle in which water vapor is absorbed by a concentrated desiccant/water solution and then reconcentrated with heat. **Figure 6** shows the basic components of a liquid desiccant system. The conditioner brings the process air into contact with the desiccant solution either through a falling film heat exchanger or a spray tower. The process air is dried and simultaneously cooled in this process because the *conditioner* uses cooling water from a cooling tower or chiller to remove the heat of sorption from the air stream. What takes two stages in a solid desiccant system is accomplished in a single stage in a liquid system. The *regenerator* heats the weak desiccant solution in the presence of a scavenging air stream similar to the reactivation air in the solid desiccant system to reconcentrate the solution. The heat is provided by a hot water boiler in packaged units, but may be provided by steam lines in a larger industrial system. The *interchange heat exchanger* cools the hot concentrated solution leaving the regenerator and simultaneously preheats the weak solution entering the regenerator. A packaged system would include, in addition to these three components, a hot water boiler to provide heat for the regenerator and a cooling tower to provide cooling for the conditioner.

The operation of a liquid desiccant is contrasted with vapor compression and solid desiccant systems in **Figure 7**. It can be seen that the cooling tower picks up more of the cooling load, requiring a smaller, dry-coil vapor compression system for post-cooling.



Source: OA6000 A Liquid Desiccant Dedicated Outdoor System, AIL Research, Inc.

**Figure 6. Liquid Desiccant Components**

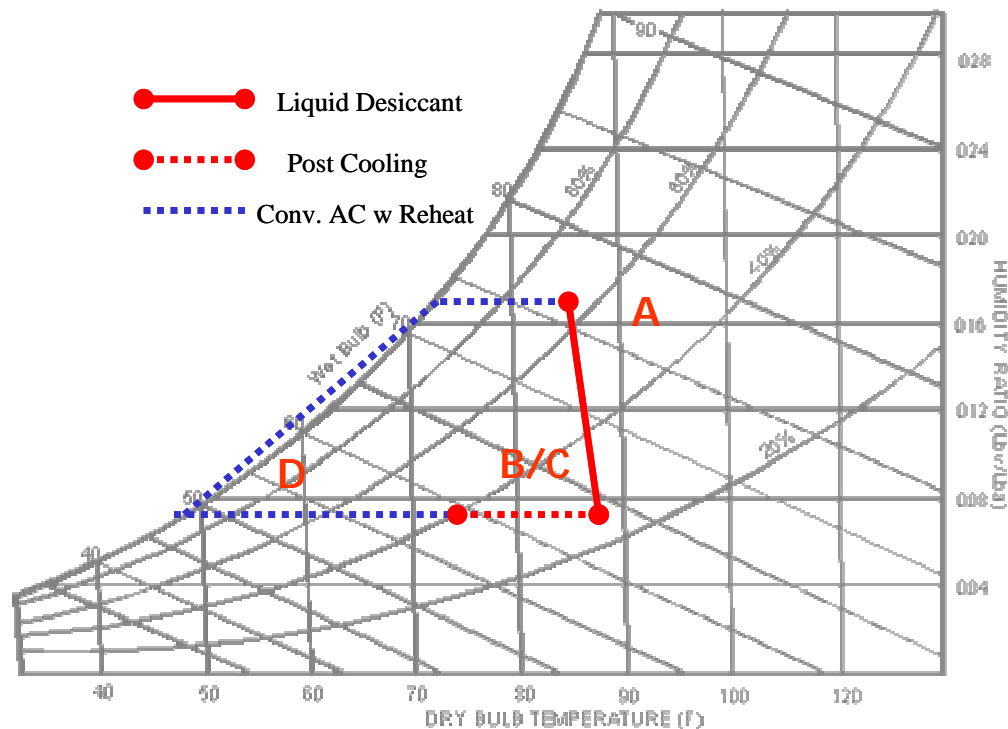

**Figure 7. Temperature and Humidity Changes in a Liquid Desiccant System**

There are eight key parameters that affect the performance of a desiccant system:<sup>5</sup>

1. **Process air moisture** – The greater the moisture load of the process air, the more moisture that will be removed by the desiccant and the higher the temperature of the dried air exiting the desiccant. Industrial processes typically utilize conditioned air that has already been dried for space comfort (75° F, 56 gr/lb. moisture.) In cases where deep drying is needed, industrial systems may use refrigerated air as the input. For commercial applications where dehumidification of makeup air is the focus, the moisture loads are much higher (90°, 120 gr/lb.) Desiccant systems are a reversible cycle so the inlet moisture conditions determine the characteristics of the entire cycle.
2. **Process air temperature** – Together with the moisture load of the process air, the temperature of that air determines the vapor pressure, which in turn determines how much moisture can be adsorbed/absorbed and how much energy is needed for reactivation. In some systems, the temperature and the moisture load of the process air can be manipulated by mechanical cooling, indirect evaporative cooling, or some other heat sink that can cool the process air. Liquid desiccant systems have cooling integrated with dehumidification. Both precooling for solid desiccants and internal cooling of liquid desiccants enhance the system's ability to remove moisture.

<sup>5</sup> This discussion is taken from *The Dehumidification Handbook, Second Edition*, Munters Cargocaire, Amesbury, Massachusetts, 1990.

3. **Process air velocity through the desiccant** – The slower the air velocity through the desiccant, the drier (and warmer) the process air will become. Some industrial systems use a low air velocity to achieve deep drying. For commercial comfort applications where deep drying is not required, a higher air velocity allows the use of a smaller, more economical system. This approach minimizes the size of the system required, thereby minimizing capital cost – at the expense of higher parasitic fan-power requirements.
4. **Reactivation air temperature** – The higher the temperature of the reactivation air, the more moisture that is given up during reactivation. The drier that the desiccant can be made during reactivation, the more moisture that it can absorb from the process air stream. In the case of industrial processes that utilize conditioned air or precooling, reactivation can be achieved by using 190° F. This temperature regime is perfect for a small or moderately sized CHP system. In the case of the commercial systems treating outside air (except for those using precooling), effective reactivation requires temperatures of 250-300° F. This higher temperature requirement complicates the matching of desiccants with CHP. To achieve the higher temperatures, either supplemental firing would be required or the CHP system must be set to deliver steam – an option that can cut in half the amount of heat that can be effectively delivered to the process. Direct use of the exhaust from a microturbine with dilution to bring the temperature down to the appropriate range, would also be an option. The reactivation energy required to release the required moisture from the desiccant (Btu/lb of water removed) goes up as the reactivation temperature goes down.
5. **Reactivation air moisture** – The moisture contained in the reactivation air stream, along with the temperature described above, affects the temperature requirements needed to remove the required moisture from the desiccant. This variable generally does not exert a big impact on the process design, except possibly at very low reactivation temperatures. However, it is important for the system to be adequately sealed so that moist reactivation air does not cross over into the process air stream.
6. **Reactivation air velocity through the desiccant** – Reactivation air delivers heat and carries away moisture from the desiccant. The heat delivery aspect is what controls the volume and velocity of air that must be delivered. If velocity is constant, then control of the reactivation process is achieved by varying the heat input to achieve a specific temperature in the exhaust air stream. The hot reactivation air is cooled by the desorption process, analogous to evaporative cooling. Typically, air temperatures leaving the desiccant on the reactivation side are on the order of 120° F. Higher temperatures in the exhaust stream indicate that desorption is, for practical purposes, complete and heat is just being wasted. Velocity of air is important in liquid desiccant systems. Too high an air velocity will entrain droplets of the corrosive desiccant solution and carry it into the ductwork.
7. **Amount of desiccant presented to the air stream** – in a system using a desiccant wheel, this variable can be increased, with a resulting improvement in moisture removal, by increasing the depth of the wheel or by increasing the speed that the wheel rotates. There are operational trade-offs associated with both of these options.

A deeper wheel increases the fan requirements. A faster rotation of the wheel increases the heat carryover from the reactivation side to the process side. Pressure drop and heat carryover are also issues for liquid desiccant systems when the rate of flow is increased.

8. **Desiccant sorption-desorption characteristics** – Different desiccant materials have different sorption characteristics as a function of temperature and humidity of the process air. For deep drying in certain industrial processes, molecular sieves are preferred. For comfort applications, lithium chloride and Type 1 silica gel are preferred. The greater the capacity of the desiccant to hold moisture in the applicable process region, the lower will be the mass of the desiccant that must be heated and cooled in the process cycle to remove a given quantity of moisture. The lower the mass of desiccant for the amount of moisture removed, the more efficient is the dehumidification process.

These factors combine to determine the performance of the system both for sizing at design conditions and also to determine control strategies and annual energy consumption as the design load changes. One measure of performance of the desiccant wheel is the latent energy contained in the moisture that is removed from the air stream divided by the energy input. This coefficient of performance (COP) is on the order of 0.5 to 0.8 for systems available today. This COP should not be confused or compared with a cooling COP which is the energy removed from the conditioned space divided by the energy input. In the case of desiccants, the desiccant alone does not remove the energy from the space, it merely transforms latent load (moisture content) into sensible load (higher temperature.) As the examples in the next section will show, desiccant systems with heat exchange and supplementary cooling can reduce the vapor-compression cooling load in an application, and this reduced cooling capacity is produced by thermal energy consumption – so an implicit cooling COP could also be calculated. Such a number, however, would be highly specific to application and geography.

#### 4. System Cost and Performance Characteristics

Using a detailed building load analysis model designed specifically for desiccant applications<sup>6</sup>, three make-up air dehumidification applications (hospital, retail, supermarket) in three cities (Miami, Atlanta, New York) were developed. The applications were chosen to reflect a range of desiccant size requirements, thermal loads, and electric load factors. Supermarkets and hospitals are considered very good desiccant markets. Of the three applications, only one, hospitals, is considered to be a good market for traditional CHP. The cities were chosen because they all have humid summer conditions – though the length of this humid season varies widely from South to North. **Table 1** summarizes the application characteristics and **Table 2** summarizes the design conditions for the three cities.

---

<sup>6</sup> DesiCalc Demo Version 1.1, InterEnergy Software, 1998-1999.

**Table 1. Application Characteristics**

	System 1 Supermarket	System 2 Retail	System 3 Hospital
Building Size (sq.ft.)	50,000	60,000	500,000
Number of Floors	1	1	6
Baseline Cooling System	Constant volume 8.9 EER packaged DX rooftop unit	Constant volume 8.9 EER packaged DX rooftop unit	Constant volume Water Cooled Chiller 0.68 kW/ton
Economizer	Temp. Controlled	Temp. Controlled	None
Heating	Reclaim plus Electric	Gas	Gas
Relief Air Heat Recovery	No	No	No
Outside Air Required (scfm)	4,000	18,000	60,000

**Table 2. Climate and Rate Characteristics**

	Units	Miami	Atlanta	New York
<b>Climate Conditions and Design Data</b>				
1% Design Day Dry Bulb/Mean Coincident Wet Bulb	Deg. F	90/77	91/74	89/73
1% Design Wet Bulb/Mean Coincident Dry Bulb	Deg. F	77/83	73/81	73/80
Heating Degree Days	HDD	200	2991	4910
Cooling Degree Days	CDD	4910	2991	1052

The highest dehumidification load conditions occur at the design wet bulb temperature; the highest sensible cooling load occurs at the design dry bulb temperature. In spite of the large annual differences in climate for the three cities, the design conditions are fairly similar. Therefore, equipment sizing and selection for each application was assumed to be the same for all cities. Both liquid and solid desiccant systems were evaluated for each application.

- Solid Desiccant System** – a two-wheel system with post cooling (see Figure 2) was selected for each application. The desiccant wheel dehumidifies and warms the outdoor make-up air and the sensible heat wheel cools the process air and simultaneously preheats the reactivation air-stream. Supermarket systems typically do not include the heat exchange process as the warm dried air counteracts excessive store cooling from the open refrigerated cases. However, for this analysis, the heat exchange step was included, primarily to reflect the energy saving potential of other make-up air applications in this size range. According to the vendor, reactivation for this system requires a direct gas burner or 40-60 psig steam. Fan energy is required on the process side and on the reactivation side. The solid desiccant system specifications, cost, and performance for these examples are shown in **Table 3**.

- **Liquid Desiccant System** – The liquid desiccant system consists of a conditioner where the make-up air is dehumidified and simultaneously cooled, a regenerator that reconcentrates the desiccant solution by heating to 180-200° F. to drive off the moisture absorbed in the conditioner, and a cooling tower to provide the cooling water for the conditioner. In applications that use direct expansion rooftop units for cooling, like the supermarket and the retail store, a cooling tower would need to be installed. In buildings that use a central water chiller, a cooling tower would already be part of the central cooling system. It would only be necessary to ensure that this cooling tower had adequate capacity for the dehumidification load. The liquid system has fan loads for the process air and regeneration air streams and pumping loads for the desiccant solution and cooling tower. The cooling tower performance, for these examples, was based on the use of relief air. Generally, cooling towers use outdoor air. The liquid desiccant system specifications, cost, and performance for the three examples are shown in **Table 4**.

In all cases, the desiccant system was sized to meet the outdoor air load. The load analysis program provided the energy use and energy cost impacts of installing a solid desiccant system with a gas-fired reactivation system heating outdoor air. In this configuration and for these applications, return air is either not available as the source of reactivation air or is the source stream for the central air conditioner.

The capital costs reflect custom product configurations available in the higher flow rate capacities needed for these integrated applications. Heat exchange equipment is included in the capital cost estimate. The installation costs include materials, construction labor, engineering, and project management typical of a large-scale HVAC project. Standardized desiccant products that are being developed in sizes smaller than 5,000 scfm process air are typically less costly and cheaper to install than a custom system that can be integrated with CHP. The avoided cost of electric air conditioning capacity is shown as a credit on new installations.

**Table 3. Solid Desiccant System Cost and Performance for Three Applications – Current Year**

Cost & Performance Characteristics Desiccant Dehumidification Systems (Stand-Alone Operation)	System 1S (DF) <sup>i</sup>	System 2S (DF)	System 3S (DF)
Application	Supermarket	Retail	Hospital
Process Air Volume (scfm)	5,000	20,000	60,000
Dehumidification	Des. Wheel	Des. Wheel	Des. Wheel
Desiccant Equipment <sup>ii</sup>	Munters S25 Superaire	2 Munters HR30 Makeup Air Units	2 Munters ICA 3500 Integrated Custom AHUs
Heat Exchange, Heat Removal	n.a.	Heat Wheel, return air/reactivation air	Heat Wheel, return air/reactivation air
Post Cooling Type	DX	DX	Chiller
Moisture Removal (lbs/hr at design wet bulb temp.) <sup>iii</sup>	179	798	2,967
Regeneration Air Volume (scfm) <sup>iv</sup>	1,667	6,667	20,000
Regeneration Heat Source	Direct Fired or 60 lb steam	Direct Fired or 60 lb steam	Direct Fired or 60 lb steam
Regeneration Temperature (deg. F)	250-300	250-300	250-300
Design Fuel Input (MMBtu/hr) <sup>v</sup>	0.26	1.24	4.51
Moisture Removal Thermal COP <sup>vi</sup>	0.68	0.65	0.66
Electrical Requirements (kW) <sup>vii</sup>	4	16	48
Latent Cooling Capacity (tons) <sup>viii</sup>	24	83	406
Dry Coil Cooling Capacity (tons) <sup>ix</sup>	71	134	1,008
Cooling System Energy Cons. (kW/ton) <sup>x</sup>	1.4	1.4	0.68
Desiccant Equipment Cost <sup>xi</sup>	\$65,000	\$150,000	\$360,000
Ancillary Equipment and Installation <sup>xii</sup>	\$24,067	\$59,583	\$153,150
Total Retrofit Installed Cost	\$89,067	\$209,583	\$513,150
Avoided Cooling Costs	(\$38,400)	(\$99,600)	(\$324,800)
Net Costs for New Installation	\$50,667	\$109,983	\$188,350
O&M Cost (\$/scfm-year) <sup>xiii</sup>	\$0.090	\$0.075	\$0.060

**Table 4. Liquid Desiccant System Cost and Performance for Three Applications – Current Year**

Cost & Performance Characteristics Desiccant Dehumidification Systems (Stand-Alone Operation)	System 1L (LT)	System 2L (LT)	System 3L (LT)
Application	Supermarket	Retail	Hospital
Process Air Volume (scfm)	5,000	20,000	60,000
Dehumidification	Liquid Des.	Liquid Des.	Liquid Des.
Desiccant Equipment <sup>xiv</sup>	Kathabar 400SP Packaged Unit	Kathabar 2000SFV Conditioner, 15FP Regen.	Kathabar 6000 FV Conditioner, 40FP Regen.
Heat Exchange, Heat Removal	15 ton Cooling Tower	65 ton Cooling Tower	250 ton Cooling Tower
Post Cooling Type	DX	DX	Chiller
Moisture Removal (lbs/hr at design wet bulb temp.)	179	798	2,967
Regeneration Air Volume (scfm)	1,667	6,667	20,000
Regeneration Heat Source	Hot Water	Hot Water	Hot Water
Regeneration Temperature (deg. F)	200	200	200
Design Fuel Input (MMBtu/hr) <sup>xv</sup>	0.30	1.36	5.04
Moisture Removal Thermal COP	0.59	0.59	0.59
Electrical Requirements (kW) <sup>xvi</sup>	6.5	26	78
Latent Cooling Capacity (tons)	24	83	406
Dry Coil Cooling Capacity (tons)	71	134	1,008
Cooling System Energy Consumption (kW/ton)	1.4	1.4	0.68
Desiccant Equipment Cost <sup>xvii</sup>	\$51,000	\$137,000	\$243,000
Ancillary Equipment and Installation	\$26,814	\$81,592	\$204,810
Total Retrofit Installed Cost <sup>xviii</sup>	\$77,814	\$218,592	\$447,810
Avoided Cooling Costs	(\$38,400)	(\$99,600)	(\$324,800)
Net Costs for New Installation	\$39,414	\$118,992	\$123,010
O&M Cost (\$/scfm-year) <sup>xix</sup>	\$0.150	\$0.125	\$0.113



<sup>i</sup> Key Code used in the Tables

**Applications**

1 = 5,000 scfm (supermarket)

2 = 20,000 scfm (retail)

3 = 60,000 scfm (hospital)

**Desiccant Type**

S = Solid

L = Liquid

**Reactivation Energy**

LT = Hot water

HT = 60 lb. Steam

DF = Direct Fired

DE = Direct Exhaust

<sup>ii</sup> Equipment selection and study estimate equipment pricing provided by Munters America Corporation.

<sup>iii</sup> Based on Design Conditions for the Application in Atlanta.

<sup>iv</sup> Based on standard 3:1 Process Air/Reactivation Air configuration.

<sup>v</sup> Based on the higher heating value of natural gas, i.e. 10% unrecoverable latent energy assumed compared with steam systems heating air.

<sup>vi</sup> Latent energy content of the water removed divided by the energy content of the fuel input. It should be noted that this measurement is not the same as an air conditioning COP as moisture removal, by itself, does not remove energy from the space. It merely transforms latent heat into sensible heat.

<sup>vii</sup> Personal Communication, Douglas Kosar, Principal Research Engineer, Energy Resources Center, University of Illinois at Chicago, Desiccant cost and performance specifications are being prepared for publication in *CHP Resource Guidebook*, [www.erc.uic.edu](http://www.erc.uic.edu).

<sup>viii</sup> Calculated as the difference between the air conditioning capacity of the baseline building and the desiccant controlled building based on the DesiCalc model output for Atlanta. In the DesiCalc model analysis, the baseline building is assumed to control humidity by over-cooling and reheat. Many buildings do not control explicitly for humidity so the actual cooling capacity reductions resulting from the use of a desiccant system might be much less. In that case, the desiccant controlled building is providing an additional service for the application.

<sup>ix</sup> From the Desicalc model runs for Atlanta. This is the electric air conditioning capacity of the desiccant controlled building. The sum of the sensible cooling capacity and the latent cooling provided is equal to the electric cooling capacity required by the baseline building.

<sup>x</sup> Desicalc Model default for each application.

<sup>xi</sup> Munters Study estimate for equipment available today.

<sup>xii</sup> For the solid system, based on equipment cost plus gas and electric connections; additional costs for engineering, installation, and project management assumed to be 32% of equipment costs.

<sup>xiii</sup> Personal Communication, Douglas Kosar

<sup>xiv</sup> Equipment specifications and equipment pricing provided by Kathabar, Inc.

<sup>xv</sup> Based on 1,700 Btu/lb of moisture removed – assumed to be based on hot water input not gas combustion.

<sup>xvi</sup> Personal Communication, Douglas Kosar

<sup>xvii</sup> Study estimate equipment pricing for the conditioner and the regenerator modules available today provided by Kathabar, Inc.

<sup>xviii</sup> For the liquid system, costs include gas and electric connection, controls, plumbing work for the piping runs, and the cooling tower installations. Engineering, installation, project management is assumed to be 32% of the total equipment and materials costs.

<sup>xix</sup> Personal Communication, Douglas Kosar

## 5. Desiccant Integration with CHP

Integration of desiccant systems with an on-site generator requires correct sizing of the prime mover thermal output and temperature characteristics to the desiccant reactivation energy and air-flow requirements. On a seasonal basis, it is also important to consider other thermal applications at the site, as annual desiccant thermal load factors can be very low.

Liquid desiccants, having internal cooling provided by cooling tower water or chilled water, are capable of providing equivalent dehumidification as solid desiccant systems with lower temperature reactivation of the desiccant. The liquid desiccant systems described in the previous example are regenerated with 190-200° F hot water. This temperature range is well within the heat delivery capabilities of reciprocating engines and microturbines – the dominant generating technologies within the size range of interest for most desiccant applications. Solid desiccant wheel systems used in industrial applications to dehumidify preconditioned air are also capable of being reactivated by hot water. However, the two wheel desiccant systems described for this analysis that treat very humid outside air, require reactivation temperatures of 250-300° F to achieve design performance. This temperature range is above the temperature range of typical heat recovery systems employed with small engines and microturbines. However, there are several options for system matching with both engines and microturbines as will be described in this section.

### 5.1 Direct Exhaust Systems

Microturbine and turbine exhaust consists primarily of heated air, in which combustion products and water vapor are at a very low level. Further, microturbines operating on air bearings have no potential to carry over lube oil into the air stream. This air stream can be used directly for process heating or as a source of preheated air for a number of industrial processes. However, current desiccant wheels cannot withstand temperatures above 300-350° F. Above this temperature, plastic seals will start to melt and the desiccant substrate itself may become damaged. Microturbine exhaust is in the range of 500-600° F. Therefore, the microturbine exhaust must be diluted with outside air before it is passed across the reactivation section of the desiccant wheel. Direct exhaust systems can extract nearly all of the available sensible heat from the exhaust stream. While a temperature range of 250-300° F is required entering the reactivation section, the exit temperature is around 120° F due to the cooling effect of the water vapor desorption from the desiccant. The volume of dilution air is exhausted at a temperature that is, at design conditions, 30° F higher than inlet conditions. This heating effect must be considered in the overall energy balance. **Figure 8** shows the size and temperature matching for a 60kW microturbine and a two-wheel desiccant system. The direct exhaust system can support a desiccant system of over 8,500 scfm with design moisture removal of over 275 lb/hr.

Direct exhaust systems also avoid the cost of the heat recovery water heater (HRWH.) Due to the annual load characteristics of the desiccant system in most climates, however, it would be more economic to have a modulating exhaust damper that can redirect all or part of the exhaust to an HRWH. In this system the advantages of direct exhaust reactivation of the desiccant can be achieved, and hot water can be made available during the winter for space heating or water heating.

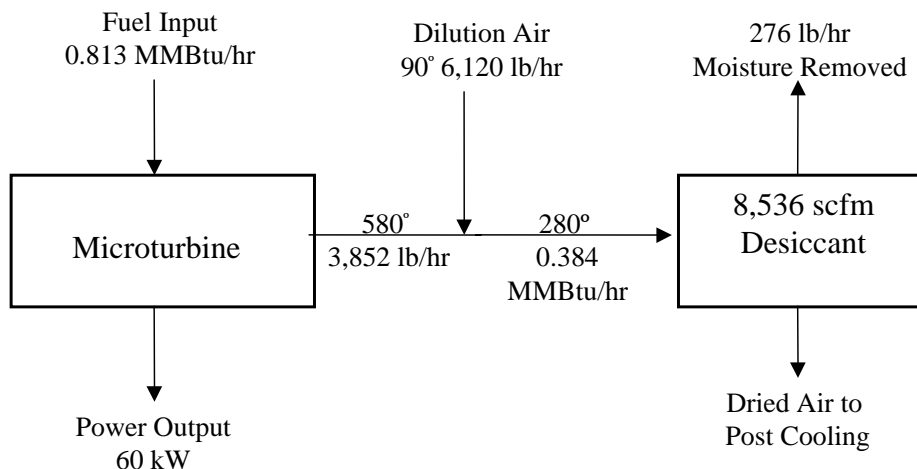

### Direct Exhaust Reactivation

**Figure 8. Microturbine/Direct Exhaust Reactivation System**

Reciprocating engine exhaust cannot be used for direct reactivation of desiccants. Reciprocating engines, even lean burn engines, have exhaust streams that have much higher moisture content than turbine exhaust. To avoid condensation, engine exhaust must be kept above 300-350° F, thereby making it unsuitable for direct use as the reactivation air-stream.

## 5.2 High Temperature Desiccant Reactivation System

Both microturbines and engines are capable thermodynamically of providing high temperatures to a desiccant or other thermally activated technology. Engines can direct the exhaust to a heat recovery steam generator (HRSG.) However, only about 40-67% of the recoverable heat from an engine generator is in the exhaust gas stream with the balance in the engine jacket cooling water and lube oil coolers. A microturbine, like its larger turbine cousins, can also be paired with a small HRSG. The lower exhaust temperature of the recuperated microturbine means that only a small portion of the exhaust heat can be recovered in this way. **Figure 9** shows a hypothetical<sup>7</sup> microturbine system providing 60 lb steam for high temperature desiccant reactivation. The direct exhaust system captures the energy from 580° to 120° F, whereas the steam system is able to capture only the energy from 580° to 300° F. Therefore, this system is only able to support a desiccant system that is two-thirds as large as the direct exhaust system. In the winter, additional heat can be extracted from the heat recovery system to provide hot water or low-pressure steam for heating.

**Figure 10** shows a high temperature reactivation system based on a Cummins lean burn 1100kW reciprocating engine generator. The 2 million Btu/hour in the exhaust can support a 45,600 scfm desiccant, somewhat smaller than the hospital example defined in the previous section. An additional 1.7 million Btu/hr of 203° water is available at all times from the jacket water and lube-oil cooler.

<sup>7</sup> The Microgen heat recovery water heater used in conjunction with current Capstone Microturbines has a temperature limit of 240° pressurized hot water. The HRSG shown in the figure is not a standard product.

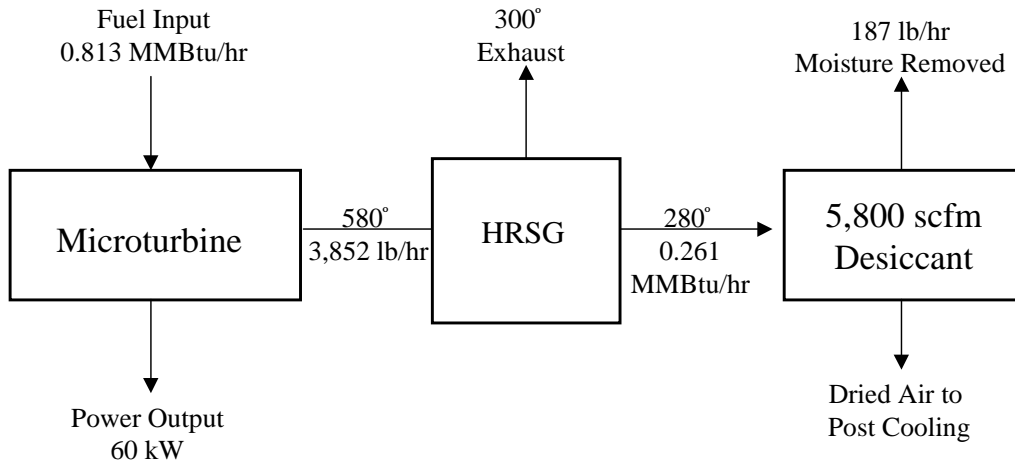

60 psig Steam Reactivation System

Figure 9. Microturbine Steam Reactivation System

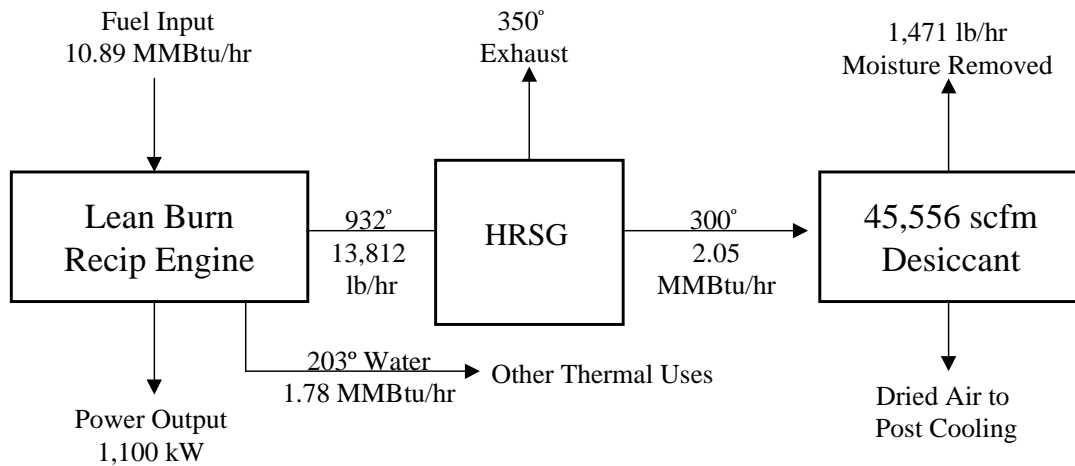

60 psig Steam Reactivation System

Figure 10. Reciprocating Engine Steam Reactivation System

### 5.3 Low Temperature Heat Recovery with Supplemental Firing

The CHP system can be set up to provide 190-200° hot water which is used to preheat the air-stream for a gas burner that brings the air temperature up to the range of a direct-fired or high temperature reactivation system. In this system, the CHP system provides 50-55% of the heat input to the reactivation air-stream. The gas burner provides the remainder. Because the CHP system is only providing about half of the reactivation energy, the desiccant system is about twice as large in comparison to the generator capacity as one in which all of the energy is

provided by recovered heat. **Figures 11 and 12** show this system for a 60kW Microturbine and an 1100kW gas engine.

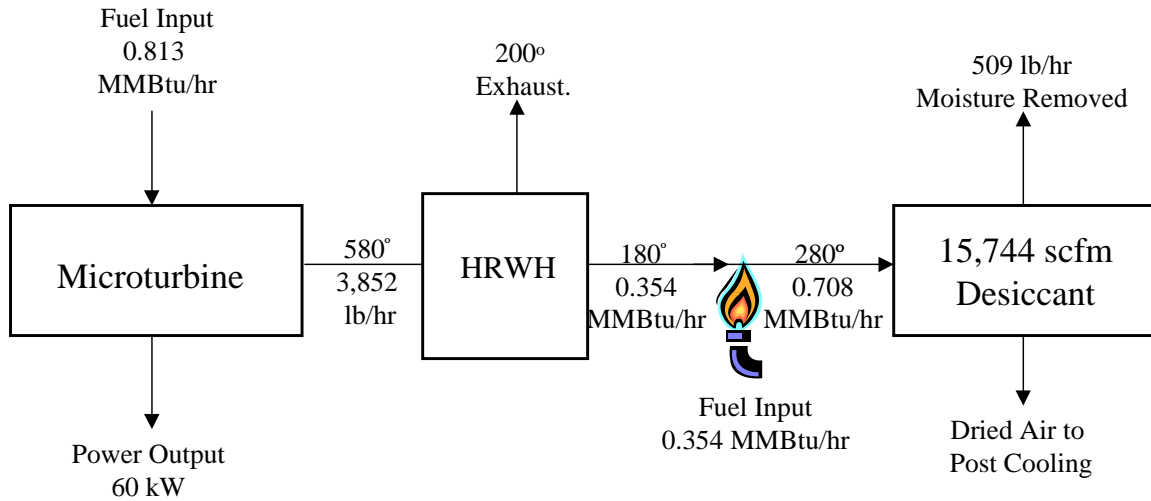

**Figure 11. Microturbine Low Temp System with Supplemental Firing**

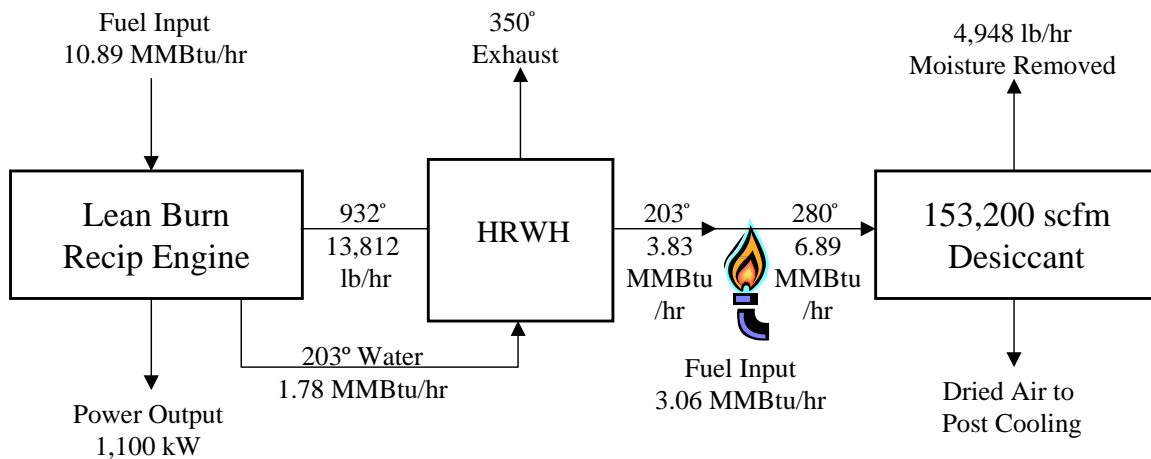
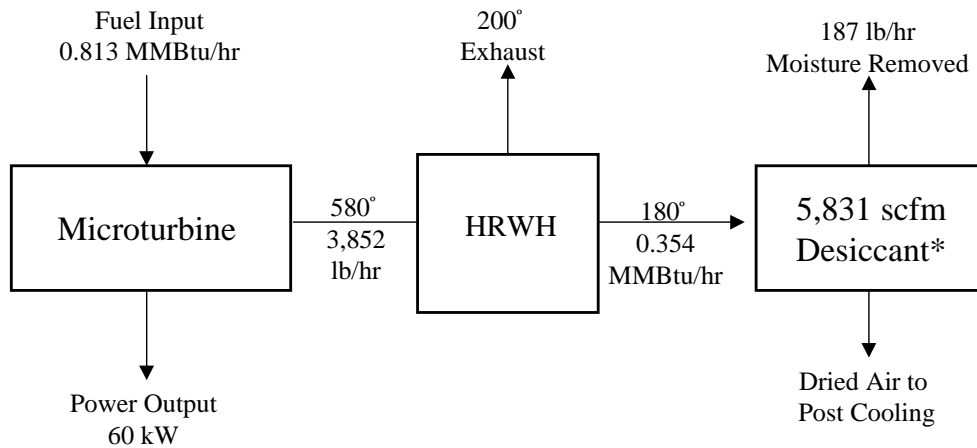

**Figure 12. Reciprocating Engine Low Temp System with Supplemental Firing**

#### 5.4 Low Temperature Reactivation System

A standard configuration for a direct-fired or high temperature desiccant is to have three-fourths of the wheel exposed to the process air, and one-fourth for reactivation. Process air and reactivation air is thus in the ratio of 3:1. With a lower reactivation temperature of 190-200° F, the process/reactivation air ratios would need to be in the ratio of 1:1. In other words, half the desiccant wheel would be exposed to the process air stream and half would be exposed to the reactivation air. The 1:1 (180/180) configuration requires a desiccant wheel that is about 30% larger than a 3:1 (270/90) configuration. In addition, the reactivation energy is increased because there is a higher volume of heated air exiting the wheel (wasted energy) than in the 3:1

configuration. It was assumed that about 30% more energy would be required for the same moisture removal capability for the 1:1 low temperature system as for the standard 3:1 direct fired or steam reactivated system. Such a system could provide reasonable comfort control and reduction of sensible cooling load (in a two wheel design) but would not be suitable for applications requiring very low relative humidity from make-up air – such as the hospital example. **Figures 13 and 14** show the low temperature 1:1 ratio systems for the microturbine and engine cases. In the microturbine case, the low temperature system provides equivalent moisture removal as the high-temperature heat recovery case. However, in the low temperature case the desiccant wheel is about 30% larger thereby raising capital costs and associated parasitic losses are also increased.



\* Effective size, actual size = 7,871 scfm

**Figure 13. Microturbine Low Temperature 1:1 System**

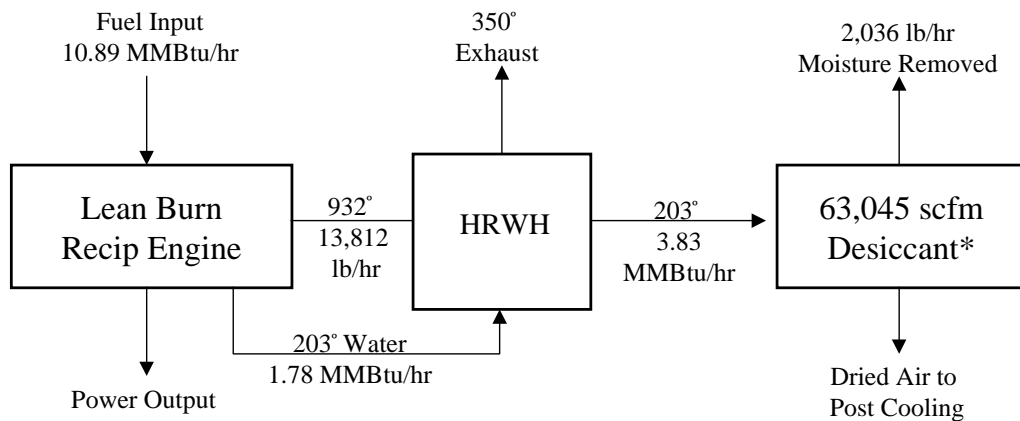

\* Effective size, actual size = 85,000 scfm

**Figure 14. Engine Low Temperature 1:1 System**

**5.5 Summary of Heat Recovery Options for Solid Desiccant Systems**

The four configurations for a desiccant wheel matching to a 60kW microturbine are summarized in **Table 5**. The table shows the size desiccant that can be served by the recovered heat in each configuration. **Table 6** shows the size of CHP system that would match up with a specific application (10,000 scfm, 323 lb/hr moisture removal) based on the Capstone C60 thermal characteristics on a unit output basis.

**Table 5. Desiccant Wheel Thermal Matching to a 60kW Microturbine**

Microturbine Specifications									
Capacity kW	60								
Heat Rate But/kWh HHV	13,556								
Exhaust Temp at Full Load °F	580								
Exhaust Mass lb/sec.	1.07								
Thermal Matching	Final Exhaust Temp	Recovery Heat Available	Gas Firing	Reactivation Energy			Desiccant Size		
	° F	Btu/hr	Btu/hr	Btu/hr	Btu/scf	Btu/lb H <sub>2</sub> O	scfm	H <sub>2</sub> O lb/hr	
Hot Water 1:1 Wheel	200	354,230		354,230	60.8	1,881	5,831*	188	
Hot Water/Supplemental Firing	200	354,230	354,230	708,460	45.0	1,393	15,744	509	
Direct Exhaust	120	384,112		384,112	45.0	1,393	8,536	276	
High Temperature	300	261,012		261,012	45.0	1,393	5,800	187	

\* Comparable size of a high temperature system. Actual wheel size is 30% larger.

**Table 6. Generator Sizing to a Specific Desiccant Specification**

Generator Matching to a Specific Desiccant Application	Generator Size	Final Exhaust Temp	Recovery Heat Available	Gas Firing	Reactivation Energy			Desiccant Size	
	kW	° F	Btu/hr	Btu/hr	Btu/hr	Btu/scf	Btu/lb H <sub>2</sub> O	scfm	H <sub>2</sub> O lb/hr
Hot Water 1:1 Wheel	103	200	607,500		607,500	60.8	1,881*	10,000	323
Hot Water/Supplemental Firing	38	200	225,000	225,000	450,000	45.0	1,393	10,000	323
Direct Exhaust	70	120	450,000		450,000	45.0	1,393	10,000	323
High Temperature	103	300	450,000		450,000	45.0	1,393	10,000	323
Direct Fired System	n.a.	n.a.	n.a.	500,000	500,000	50.0	1548	10,000	323

\* Comparable size of a high temperature system. Actual wheel size is 30% larger.

Tables 7 and 8 show the cost and performance of selected CHP desiccant systems in the 5,000 scfm and 20,000 scfm applications defined in the previous section.

**Table 7. Performance for 5,000 and 20,000 scfm Applications as Part of an IES – Current Year**

IES System Parameters (Integrated CHP Operation)	System 1S (LT, HT, DE)	System 1L (LT)	System 2S (LT)	System 2S (HT, DE)
CHP Unit Characteristics	Microturbine <sup>xx</sup>	Microturbine	Lean Burn Recip. Engine <sup>xxi</sup>	4 x Microturbine Multipack <sup>xxii</sup>
Net Electrical Capacity (kW)	60	60	310	240
Electric Heat Rate (Btu/kWh HHV)	13,556	13,556	11,192	13,556
Electric Efficiency (HHV)	25.2%	25.2%	30.5%	25.2%
Total Thermal Available (MMBtu/hr)	0.331	0.331	1.619	1.324
Total Electric and Thermal Energy Utilization	65.9%	65.9%	77.2%	65.9%
<b>190 deg. Hot Water Reactivation (LT)</b>				
Heat Available from CHP Unit	0.331	0.331	1.619	Not Analyzed
Design Reactivation Energy Required <sup>xxiii</sup>	0.310	0.304	1.445	
Available for Other Processes	0.021	0.027	0.174	
Design CHP Thermal Eff. Desiccant Only <sup>xxiv</sup>	63.2%	62.6%	72.2%	
Annual CHP Thermal Efficiency <sup>xxv</sup>	42.3%	43.6%	37.2%	
Design Thermal Efficiency All Uses	65.9%	65.9%	77.2%	
Annual Thermal Efficiency All Uses <sup>xxvi</sup>	48.9%	50.2%	38.8%	
<b>60 lb. Steam Reactivation (HT)</b>				
Heat Available from CHP Unit	0.242	Not Required	Undersized by 50% could be matched with supplemental firing	0.969 <sup>xxvii</sup>
Design Reactivation Energy Required	0.238			1.112
Available for Other Processes	0.004			n.a.
Design CHP Thermal Efficiency Desiccant Only	54.5%			59.3%
Annual CHP Thermal Efficiency	37.9%			30.7%
Design Thermal Efficiency All Uses	55.0%			55.0%
Annual Thermal Efficiency All Uses	43.7%			32.2%
<b>Direct Exhaust Reactivation (DE)</b>				
Heat Available from CHP Exhaust	0.384	Not Required	Not Feasible	1.536
Design Reactivation Energy Required	0.238			1.112
Hot Water Generation (split exhaust)	0.163			0.366
Design CHP Thermal Efficiency Desiccant Only	54.5%			59.3%
Annual CHP Thermal Efficiency	37.9%			30.7%
Design Thermal Efficiency All Uses	74.5%			70.6%
Annual Thermal Efficiency All Uses	47.6%			33.1%



---

<sup>xx</sup> Performance specifications based on Capstone C60 microturbine, Capstone Data Sheet, Capital and O&M Costs adapted from *Gas Fired Distributed Generation Technology: Microturbines*, Energy and Environmental Analysis, Inc. May 2003.

<sup>xxi</sup> Performance specifications based on Caterpillar 3408 TA90HCR, Caterpillar Data Sheet, Capital and O&M Costs adapted from *Gas Fired Distributed Generation Technology: Reciprocating Engines*, Energy and Environmental Analysis, Inc., Nov. 2003.

<sup>xxii</sup> Performance for the Multipack assumed to be identical to the single C60 unit, package costs assumed to be 90% of the single unit on a \$/kW basis.

<sup>xxiii</sup> 30% more energy required for LT system compared to HT system per Paul Dinnage, Munters -- Wheel configuration would be 180/180 (HT is 270/90 Process/reactivation wheel shares)

<sup>xxiv</sup> Thermal Efficiency = (electric energy + thermal energy utilized)/heat rate

<sup>xxv</sup> Annual thermal efficiency based on the avoided fuel used for desiccant reactivation based on the DesiCalc energy analysis for Atlanta – All annual efficiencies in the table are based on Atlanta.

<sup>xxvi</sup> Thermal efficiency based on avoided natural gas consumption for desiccant reactivation, space heating, and water heating.

<sup>xxvii</sup> Minor undersizing for desiccant reactivation was ignored in the analysis.

**Table 8. Capital and O&M Costs for Desiccant IES Systems: Applications 1 and 2 (Supermarket and Retail) – Current Year**

IES System Parameters (Integrated CHP Operation)	System 1S (LT, HT, DE)	System 1L (LT)	System 2S (LT)	System 2S (HT, DE)
CHP Unit Characteristics	Microturbine	Microturbine	Lean Burn Recip. Engine	4 x 60kW Microturbine Multipack
Net Electrical Capacity (kW)	60	60	310	248
<b>Capital and O&amp;M Costs</b>				
Prime Mover + HR Installed Cost (2003 \$/kW)	\$2,267	\$2,267	\$1,244	\$2,040
Desiccant System Installed Cost (2003 \$/kW)	\$1,484	\$1,297	\$913	\$873
Avoided Electric Cooling Capacity (2003 \$/kW)	(\$640)	(\$640)	(\$321)	(\$415)
Net System Costs (2003 \$/kW)	\$3,111	\$2,923	\$1,835	\$2,498
Prime Mover O&M Costs (\$/kWh)	\$0.0180	\$0.0180	\$0.0128	\$0.0162
Desiccant System O&M Costs (\$/kWh)	\$0.0010	\$0.0016	\$0.0006	\$0.0008
Total System O&M Costs (\$/kWh)	\$0.0190	\$0.0196	\$0.0134	\$0.0170

Capital costs and O&M costs for the prime movers were taken from the sources identified in **Table 7**. The desiccant system installed costs are taken from **Tables 5** and **6** and converted to a \$/kW basis. Desiccant system O&M was put on a \$/kWh basis.

**Table 9** shows the cost and performance for a desiccant IES system in the hospital application – 60,000 scfm. The hospital application requires very tight control of humidity levels so low temperature reactivation of the solid desiccant system was not evaluated.

**Table 9. Desiccant IES Cost and Performance for 60,000 scfm Application (Hospital)  
- Current Year**

IES System Parameters (Integrated CHP Operation)	System 3S (HT)	System 3S (HT)	System 3L (LT)
CHP Unit Characteristics	Lean Burn Engines <sup>8</sup>	Gas Turbine <sup>9</sup>	Lean Burn Engines
Net Electrical Capacity (kW)	2200	1000	2200
Electric Heat Rate (Btu/kWh HHV)	9,830	15,580	9,830
Electric Efficiency (HHV)	34.7%	21.9%	34.7%
Total Thermal Available (MMBtu/hr)	7.660	6.700	7.660
Total Electric and Thermal Energy Utilization	70.1%	64.9%	70.1%
Thermal Reactivation Type	60 psig Steam		Hot Water
Heat Available from CHP Unit	4.100	6.700	7.660
Design Reactivation Energy Required	4.062	4.062	5.044
Available for Other Processes	0.038	2.638	2.616
Design CHP Thermal Efficiency Desiccant Only	53.5%	48.0%	58.0%
Annual CHP Thermal Efficiency	39.0%	27.8%	40.1%
Design Thermal Efficiency All Uses	53.7%	64.9%	70.1%
Annual Thermal Efficiency All Uses	49.0%	47.5%	54.2%
<b>Capital and O&amp;M Costs</b>			
Prime Mover + HR Installed Cost (2003 \$/kW)	\$1,030	\$1,582	\$1,030
Desiccant System Installed Cost (2003 \$/kW)	\$233	\$513	\$204
Avoided Electric Cooling Capacity (2003 \$/kW)	(\$148)	(\$325)	(\$148)
Net System Costs (2003 \$/kW)	\$1,116	\$1,771	\$1,086
Prime Mover O&M Costs (\$/kWh)	\$0.0100	\$0.0096	\$0.0100
Desiccant System O&M Costs (\$/kWh)	\$0.0002	\$0.0005	\$0.0004
Total System O&M Costs (\$/kWh)	\$0.0102	\$0.0101	\$0.0104

<sup>8</sup> Specifications based on two Cummins QSV81G lean burn engines.

<sup>9</sup> Specifications based on one Solar Saturn 20 gas turbine.

## 6. Advanced Technology Projections

Desiccant systems are well entrenched in their historical markets: storage, pharmaceuticals, candy making, ice rinks, and supermarkets. However, current desiccant system cost and performance characteristics limit the competitiveness in comfort applications. The main issues for solid systems are the large size of the equipment, high first cost, excessive fan energy requirements, and cost of reactivation heat. Liquid systems have issues related to desiccant carry-over into the air-stream, fan and pumping requirements, high equipment cost, and complexity and maintenance issues.

The following improvements in desiccant performance are expected by 2020:

- Reductions in the capital cost of the equipment due to standardization of systems and higher volume markets compared to custom built systems – costs in 2020 about 60% to 70% of the current costs
- Improvement in heat exchanger technology and materials raising effectiveness from 70% to 90% with no increase in cost or pressure drop – this change, in the examples developed for this report, reduces the reactivation energy requirements by 9% and increases the avoided electric cooling capacity requirements by 16-22%.
- With higher temperature, liquid systems can theoretically utilize double effect regeneration similar to closed cycle absorption cooling systems. This change raises the moisture removal COPs from 0.59 to about 1.2.
- Solid desiccant system manufacturers are developing compact standardized products that utilize air conditioner condenser heat for reactivation. Future systems could use a combination of condenser heat, for preheat, followed by high temperature heat recovery from CHP systems. Combined with the increase in HX effectiveness, COPs are raised from about 0.7 to 1.15 to 1.21.
- Additional improvements can come in the form of higher efficiency fans and pumps and control mechanisms that reduce requirements during off-design hours. A 10% reduction in fan and pumping energy was assumed.
- Maintenance costs are assumed to be reduced by 20%.
- Advances in prime mover CHP technology will increase efficiency and reduce capital costs. Advanced systems have higher Electric/Thermal ratios necessitating resizing of prime movers to the applications.

**Tables 10 and 11** show the cost and performance parameters for advanced desiccant systems in the year 2020 based on the improvements described above. **Tables 12 and 13** show IES package cost and performance for the three application/size ranges.

**Table 10. Advanced Solid Desiccant System Cost and Performance – 2020 Estimate**

Cost & Performance Characteristics Desiccant Dehumidification Systems (Stand-Alone Operation)	System 1S (DF)	System 2S (DF)	System 3S (DF)
Application	Supermarket	Retail	Hospital
Process Air Volume (scfm)	5,000	20,000	60,000
Desiccant Equipment	Desiccant wheel dehumidifying make-up air, 90% efficient HX cooling process air/heating regeneration air, post cooling condenser heat used to provide a portion of reactivation energy, followed by HT firing		
Heat Exchange, Heat Removal	n.a.	Heat Wheel, return air/reactivation air	Heat Wheel, return air/reactivation air
Post Cooling Type	DX	DX	Chiller
Moisture Removal (lbs/hr at design wet bulb temp.)	179	798	2,967
Regeneration Air Volume (scfm)	1,667	6,667	20,000
Regeneration Heat Source	Direct Fired or 60 lb steam	Direct Fired or 60 lb steam	Direct Fired or 60 lb steam
Regeneration Temperature (deg. F)	300	300	300
Design Fuel Input (MMBtu/hr)	0.15	0.69	2.53
Moisture Removal Thermal COP	1.21	1.15	1.17
Electrical Requirements (kW)	3.6	14.4	43.2
Latent Cooling Capacity (tons)	28	101	487
Dry Coil Cooling Capacity (tons)	67	116	927
Cooling System Energy Consumption (kW/ton)	1.2	1.2	0.55
Desiccant Equipment Cost	\$40,000	\$105,000	\$250,000
Ancillary Equipment and Installation	\$15,087	\$41,708	\$113,000
Total Retrofit Installed Cost	\$55,087	\$146,708	\$363,000
Avoided Cooling Costs	(\$31,181)	(\$85,058)	(\$272,832)
Net Costs for New Installation	\$23,906	\$61,650	\$90,168
O&M Cost (\$/scfm-year)	\$0.072	\$0.060	\$0.048

**Table 11. Advanced Liquid Desiccant System Cost and Performance – 2020 Estimate**

Cost & Performance Characteristics Desiccant Dehumidification Systems (Stand-Alone Operation)	System 1L (HT)	System 2L (HT)	System 3L (HT)
Application	Supermarket	Retail	Hospital
Process Air Volume (scfm)	5,000	20,000	60,000
Desiccant Equipment	Liquid Desiccant dehumidifying make-up air, 90% efficient HX cooling conditioner solution/heating regeneration solution, double effect regeneration using HT heat, cooling tower using return air to cool conditioner		
Heat Exchange, Heat Removal	15 ton Cooling Tower	65 ton Cooling Tower	250 ton Cooling Tower
Post Cooling Type	DX	DX	Chiller
Moisture Removal (lbs/hr at design wet bulb temp.)	179	798	2,967
Regeneration Air Volume (scfm)	1,667	6,667	20,000
Regeneration Heat Source	Direct Fired or 60 lb steam	Direct Fired or 60 lb steam	Direct Fired or 60 lb steam
Regeneration Temperature (deg. F)	300	300	300
Design Fuel Input (MMBtu/hr)	0.15	0.67	2.47
Moisture Removal Thermal COP	1.20	1.20	1.20
Electrical Requirements (kW)	5.85	23.4	70.2
Latent Cooling Capacity (tons)	28	101	487
Dry Coil Cooling Capacity (tons)	67	116	927
Cooling System Energy Consumption (kW/ton)	1.2	1.2	0.55
Desiccant Equipment Cost	\$35,700	\$95,900	\$170,100
Ancillary Equipment and Installation	\$21,918	\$68,440	\$181,482
Total Retrofit Installed Cost	\$57,618	\$164,340	\$351,582
Avoided Cooling Costs	(\$31,181)	(\$85,058)	(\$272,832)
Net Costs for New Installation	\$26,437	\$79,282	\$78,750
O&M Cost (\$/scfm-year)	\$0.120	\$0.100	\$0.090

**Table 12. Advanced Desiccant IES Cost and Performance for Applications 1 and 2 (Supermarket and Retail applications) – 2020 Estimate.**

IES System Parameters (Integrated CHP Operation)	System 1S (LT, HT, DE)	System 1L (HT)	System 2S (HT, DE)
CHP Unit Characteristics	2 Advanced Ceramic Microturbines	2 Advanced Ceramic Microturbines	Advanced Microturbine System
Net Electrical Capacity (kW)	110	110	350
Electric Heat Rate (Btu/kWh HHV)	9,749	9,749	9,481
Electric Efficiency (HHV)	35.0%	35.0%	36.0%
Total Thermal Available (MMBtu/hr)	0.390	0.390	1.086
Total Electric and Thermal Energy Utilization	71.4%	71.4%	68.7%
<b>60 lb. Steam</b>			
Heat Available from CHP Unit	0.234	0.234	0.648
Design Reactivation Energy Required	0.133	0.149	0.623
Available for Other Processes	0.101	0.085	0.026
Design CHP Thermal Efficiency Desiccant Only	47.4%	48.9%	54.8%
Annual CHP Thermal Efficiency	42.9%	42.9%	39.0%
Design Thermal Efficiency All Uses	56.8%	56.8%	55.5%
Annual Thermal Efficiency All Uses	47.2%	47.3%	40.2%
<b>Direct Exhaust to the Desiccant</b>			
Heat Available from CHP Exhaust	0.390	n.a.	1.087
Design Reactivation Energy Required	0.133		0.623
Hot Water Generation (split exhaust)	0.257		0.464
Design CHP Thermal Efficiency Desiccant Only	47.4%		54.8%
Annual CHP Thermal Efficiency	44.7%		41.4%
Design Thermal Efficiency All Uses	71.4%		68.7%
Annual Thermal Efficiency All Uses	48.9%		40.5%
<b>Capital and O&amp;M Costs</b>			
Prime Mover + HR Installed Cost (2003 \$/kW)	\$1,100	\$1,100	\$1,000
Desiccant System Installed Cost (2003 \$/kW)	\$501	\$524	\$419
Avoided Electric Cooling Capacity (2003 \$/kW)	(\$283)	(\$283)	(\$243)
Net System Costs (2003 \$/kW)	\$1,317	\$1,340	\$1,176
Prime Mover O&M Costs (\$/kWh)	\$0.0140	\$0.0140	\$0.0110
Desiccant System O&M Costs (\$/kWh)	\$0.0004	\$0.0007	\$0.0004
Total System O&M Costs (\$/kWh)	\$0.0144	\$0.0147	\$0.0114

**Table 13. Advanced Desiccant IES Cost and Performance for Application 3 (60,000 scfm Desiccant System in a Hospital) – 2020 Estimate**

<b>IES System Parameters (Integrated CHP Operation)</b>	<b>System 3S (HT)</b>	<b>System 3S (HT)</b>	<b>System 3L (LT)</b>
CHP Unit Characteristics	Advanced Recip Engine	2 Advanced Ceramic Miniturbines	Advanced Recip Engine
Net Electrical Capacity (kW)	1250	1000	1250
Electric Heat Rate (Btu/kWh HHV)	8,979	8,749	8,979
Electric Efficiency (HHV)	38.0%	39.0%	38.0%
Total Thermal Available (MMBtu/hr)	3.906	3.460	3.906
Total Electric and Thermal Energy Utilization	72.8%	78.6%	72.8%
<b>60 lb. Steam</b>			
Heat Available from CHP Unit	2.539	2.035	2.539
Design Reactivation Energy Required	2.274	2.274	2.473
Available for Other Processes	1.632	-0.239	1.434
Design CHP Thermal Efficiency Desiccant Only	58.3%	65.0%	60.0%
Annual CHP Thermal Efficiency	42.6%	45.0%	42.5%
Design Thermal Efficiency All Uses	60.6%	62.3%	60.6%
Annual Thermal Efficiency All Uses	67.1%	66.4%	67.0%
<b>Capital and O&amp;M Costs</b>			
Prime Mover + HR Installed Cost (2003 \$/kW)	\$860	\$770	\$860
Desiccant System Installed Cost (2003 \$/kW)	\$44	\$363	\$290
Avoided Electric Cooling Capacity (2003 \$/kW)	(\$25)	(\$273)	(\$218)
Net System Costs (2003 \$/kW)	\$879	\$860	\$932
Prime Mover O&M Costs (\$/kWh)	\$0.0120	\$0.0140	\$0.0120
Desiccant System O&M Costs (\$/kWh)	\$0.0004	\$0.0004	\$0.0003
Total System O&M Costs (\$/kWh)	\$0.0100	\$0.0097	\$0.0101



## 7. Conclusions

Desiccant systems represent a class of thermally activated technologies that have potential integration with combined heat and power into an *integrated energy system* providing electricity, heat, cooling, and dehumidification for an application. This section provides conclusions on applications, system cost and performance, technology advances expected, integration potential with CHP, and economic issues affecting market potential.

### *Applications*

Desiccants have applications in industrial processes and product storage for corrosion protection, mold and fungus growth protection, product moisture regain prevention, and in product drying. Desiccants also are used to control humidity in *cold footprint buildings* such as supermarkets, refrigerated warehouses, and ice-skating rinks. An emerging market for desiccants is in controlling humidity for comfort and indoor air quality in a broader range of commercial buildings. Desiccant systems are typically used to dehumidify humid outside air prior to sensible cooling with conventional equipment.

In the industrial, warehousing, and cargo applications, the overriding consideration is the protection of product value. The capital cost and energy efficiency of the desiccant dehumidification systems were secondary considerations. Desiccant manufacturers have been very successful in meeting the needs of these markets. They have also been successful in cold footprint buildings (supermarkets, ice rinks, refrigerated warehouses) that have such large refrigeration loads that space cooling is generally not required, whereas humidity control is needed for control of refrigeration energy use, product appearance, occupant comfort and safety. In these applications desiccant based dehumidification products have been developed and have achieved significant market penetrations.

These traditional niche markets are fairly small and growth potential is limited compared with the broad range of energy-using commercial and industrial establishments. The big push in desiccant system development is in creating products that provide cost-effective dehumidification to the very large comfort conditioning markets.<sup>10</sup> Emerging issues such as indoor air quality, occupant comfort, prevention of the spread of air borne diseases, even protection against biological and chemical terrorism have spurred interest in desiccant systems as part of heating, ventilating, and air conditioning (HVAC) systems in buildings such as hospitals, restaurants, retail, and office buildings. These potential markets are huge compared with the traditional markets in which desiccant systems already compete successfully. The functions that desiccant systems provide in these markets are independent dehumidification of air, removal of standing water in cooling coils that can lead to growth and spread of airborne pathogens in the ductwork, continuous air filtration, and effective heat recovery of outdoor and return airstreams. In many cases, including the cases presented in this report, desiccant systems can reduce the electric cooling load on the application sites achieving a benefit in both capacity and energy reduction.

---

<sup>10</sup> J. Fisher, A. Hallstrom, and J. Sand, *Desiccant-Based Preconditioning Market Analysis*, Oak Ridge National Laboratory, ORNL/SUB/94-SV044/1, June 2000.

Indoor air quality (IAQ) is becoming an increasingly important issue. ASHRAE recommended ventilation loads are being incorporated into local building codes. These increased ventilation loads are lowering the sensible heat ratio (SHR) thereby creating a greater need for independent control of cooling and dehumidification.

Desiccant systems for these broad market applications must have low first cost, low fan requirements, and good energy efficiency. They must generally compete on the basis of reduced energy costs within an application, as the value of the many added services that desiccants can provide is not adequately quantified.

### ***Desiccant System Cost and Performance***

The desiccant systems designed for the commercial applications profiled for this study ranged in cost from \$13/scfm for the 5,000scfm system to \$4/scfm for the 60,000 scfm liquid desiccant system. Installed costs ranged from \$17.80/scfm to \$7.50/scfm respectively. For these comfort/IAQ applications, desiccant systems are more costly than typical HVAC systems based solely on electrically driven vapor compression cooling systems. However, in a new application, about 40-60% of the installed capital cost of a compound desiccant system can be offset by the avoided cost of cooling capacity in the building.

Reactivation COPs<sup>11</sup> range from 0.59 to 0.68 for the applications considered. Sensible cooling reductions ranged from 4.2-6.7 tons/1000 scfm. The desiccant systems, thus, can be compared as a thermally activated air conditioning system – with capital costs of about \$3,700/ton at the small end dropping to \$1,100-1,300/ton at the large end. When the avoided cost of sensible cooling capacity is considered, the capital costs drop to \$2,100/ton in the small sizes to \$300-400/ton in the large sizes. Cooling COPs<sup>12</sup> range from 0.7 to 1.1, with the higher COPs in the hospital application and the lower COPs in the retail application.

The high implicit cooling COPs in the examples result from the comparison of the desiccant system to an electrically driven HVAC system that controls humidity to the same degree as the desiccant by overcooling and reheat. In buildings where humidity is not controlled at all, or controlled poorly, the annual energy cost comparison will be much less favorable to the desiccant system. This is the challenge for desiccant systems in comfort markets – the system must compete economically based on standard practice, not on the added service and comfort that the desiccant systems provide.

Desiccant systems are easily maintained. Maintenance costs are small compared to fuel costs for regeneration and parasitic electric load for moving process and regeneration air – the sum of these three factors equals total operating cost for the system excluding capital related charges. Maintenance for liquid systems is about 70-80% higher than for wheel systems, though, again, this is still a minor part of overall operating costs. For a combined CHP/desiccant system, the maintenance costs associated with the engine and generator are an order of magnitude higher than the maintenance required for the desiccant package.

---

<sup>11</sup> Reactivation COP equals the latent energy contained in the moisture removed divided by the thermal energy input.

<sup>12</sup> Cooling COP in this example refers to the latent and sensible energy removed from the conditioned space divided by the thermal energy input in like units.

### ***Technology Advances***

To break out of the existing niche markets, desiccant systems need to be made less costly, the reactivation energies need to be reduced, and fan energy needs to be reduced. Further, the systems need to be packaged more like standard HVAC products. The approach of the entire industry is changing from one of low-volume industrial equipment suppliers to one more closely resembling the suppliers of standardized rooftop equipment. Capital costs are being addressed by standardization and volume production. Systems are being developed that utilize the heat from the air conditioning condenser to reduce or eliminate the need for fuel consumption to meet reactivation energy requirements. In liquid systems, multiple effect regenerators are being developed that increase the moisture removal COPs from 0.6 to 1.2.

In addition to changes in product cost and performance, a good part of the Federal RD&D program in this area is aimed at developing and demonstrating systems integration packages, developing means to measure (and thereby capture) additional product values.

As defined in this study, the desiccant system of the year 2020 will be 40% cheaper to purchase and install, and externally supplied energy for reactivation will be cut in half.

### ***Technical Integration Potential with CHP***

On-site generating systems produce heat and desiccant systems require heat – creating an obvious advantage for integration into an IES. The primary focus of this report is on the integration of desiccants with CHP. Several conclusions regarding this integration can be drawn:

- Overall Sizing – Desiccant systems typically range from 500 to 84,000 scfm. An 84,000 scfm desiccant system could be reactivated with the waste heat from a 2 MW reciprocating engine or a bank of microturbines or even a 2 MW GT. At 5,000 scfm the heat required could be met by a 30-100 kW engine or microturbine. Desiccant systems much below 5,000 scfm would not fully utilize the waste heat from a small engine or microturbine. Such a system might still make economic sense if there were other uses for the waste heat not needed by the desiccant system.
- Temperature Range – Liquid desiccants, with internal cooling, can be reactivated in the 190-200° F temperature range. This is well within the capabilities of engine and microturbine systems and possibly some developing fuel cell systems as well. Standard design wheel systems (i.e., 3:1 process to reactivation air ratio and without precooling), dehumidifying outdoor air, require reactivation of 250-300° F. While this higher range is still within the technical capabilities of engine and microturbine systems, the amount of heat recoverable at this temperature can be considerably less.
- Heat recovery/delivery technology – There are three basic heat recovery/delivery mechanisms available. For low temperature systems, heat recovery water heater can be used. This is the standard heat recovery approach for packaged CHP systems of the type and size that would be used. For high temperature systems, a heat recovery steam boiler can be used. This approach is not standard in this size range, and special equipment would have to be used. Also, the heat recovery potential is reduced as the exhaust temperature of the HRSB is much higher compared with the HRWH. Microturbines can also be matched up for desiccant reactivation using direct exhaust. This system would require mixing with dilution air to bring the temperature down to a range that wouldn't

damage the desiccant – typically less than 300-350°. To allow use of the waste heat for other applications, a modulating exhaust damper can be installed to direct all or a portion of the exhaust to an HRWH. Finally, desiccant wheels, that typically require high temperature waste heat for reactivation, can be redesigned to provide acceptable performance. This redesigned system would be about 30% larger and require about 30% more reactivation energy.

- Physical integration issues – Desiccant systems for comfort applications are typically installed on the rooftop. CHP systems are more usually installed next to the building in an enclosure or mechanical building. Hot water and steam heat recovery allow physical separation of the desiccant and heat recovery system. Heat is directed to the desiccant by insulated steam or hot water pipes. For direct exhaust systems, the desiccant and CHP units would work best if placed together.
- Annual energy consumption – Like air conditioning, dehumidification is a highly seasonal load. The annual energy requirements may represent only a 10-20% load factor on the design reactivation size. To achieve high thermal utilization, a CHP system would need to combine thermal loads within another application like space heating in the winter, dehumidification and/or cooling in the summer, and water heating year-round.
- Advanced desiccant technology – Some of the direction in emerging desiccant products may make it less easily integrated with CHP. There is a strong trend to provide modular systems around 1000 scfm. There is also a trend to use condenser heat for reactivation. However, these trends do not eliminate the integration potential. Numerous small desiccant systems can be connected to a prime mover by steam or hot water lines. Condenser heat can be supplemented in either quantity or quality by heat from the prime mover.

### ***Economic Issues/Market Potential***

Both CHP and desiccant developers/manufacturers are interested in exploiting the integration of the two technologies. The concept is that the market for desiccants will be enhanced if the reactivation heat can come from a “free” source like on-site generation. CHP developers believe that thermally activated technologies (TAT) such as desiccant dehumidification and absorption cooling can enhance their thermal utilization in applications that do not have the steady hot water loads found in traditional CHP markets. There is an undeniable logic to these arguments. However, the benefit of integration cannot be claimed by both the CHP system and the desiccant system. In other words, a marginally economic CHP system may become economic if it can include an economic desiccant application as part of the overall package. Alternatively, a marginal desiccant application may become economic if it can be matched up to an economic CHP system. It is not true that a marginally economic CHP system can be matched up with a marginally economic desiccant system to produce an economic IES.

Both desiccant and packaged CHP technologies have their own niche markets. Integrated systems will allow some limited immediate expansion of these markets. Particularly, CHP systems can start to compete more effectively in a broader range of commercial buildings that have limited or seasonal thermal loads but large HVAC loads that could be taken over by TATs.

However, widespread penetration of these markets will require cost and performance advances to both technologies.

A final conclusion relates to the measurement of CHP efficiency. Overall CHP efficiency can be measured as the sum of the electric and thermal energy utilized divided by the heat input. In certain cases, a system's legal status is defined by achieving threshold levels of overall efficiency. This measure, however, does not take into account the efficiency of the TAT to which the CHP system is matched. For example, the low temperature desiccant system uses more energy than the high temperature system, though both provide the same service. Because more energy is used, the CHP-IES with the low temperature system has a higher thermal efficiency measure than the high temperature system. In matters of public policy, rules designed to encourage higher efficiency of energy use should not be designed in such a way as to discourage the mating of more efficient TATs that require higher quality heat as an input so long as the services provided at the site are the same or enhanced.

## Appendix A: Psychrometric Chart Explanation

Excerpted from: David Shelton and Gerald Bodman, *Air Properties, Temperature and Relative Humidity*, Institute of Agricultural and Natural Resources, University of Nebraska, Electronic Version Issued, May 1997, (<http://www.ianr.unl.edu/pubs/generalag/g626.htm#tpc>)

Psychrometrics refers to the properties of moist air. A psychrometric chart graphically illustrates the relationships between air temperature and relative humidity as well as other properties. A better understanding of air properties and the psychrometric chart can aid in the selection and management of a livestock building ventilation system, a grain drying system, or a home humidifier.

### Definitions of Air

Three basic definitions are used to describe air under various conditions:

#### **Atmospheric air**

Contains nitrogen, oxygen, carbon dioxide, water vapor, other gases, and miscellaneous contaminants such as dust, pollen, and smoke. This is the air we breathe and use for ventilation.

#### **Dry air**

Exists when all of the contaminants and water vapor have been removed from atmospheric air. By volume, dry air contains about 78 percent nitrogen, 21 percent oxygen, and 1 percent other gases. Dry air is used as the reference in psychrometrics.

#### **Moist air**

Is a mixture of dry air and water vapor.

Due to the variability of atmospheric air, the terms dry air and moist air are used in psychrometrics. For practical purposes, moist air and atmospheric air can be considered equal under the range of conditions normally encountered.

## The Psychrometric Chart

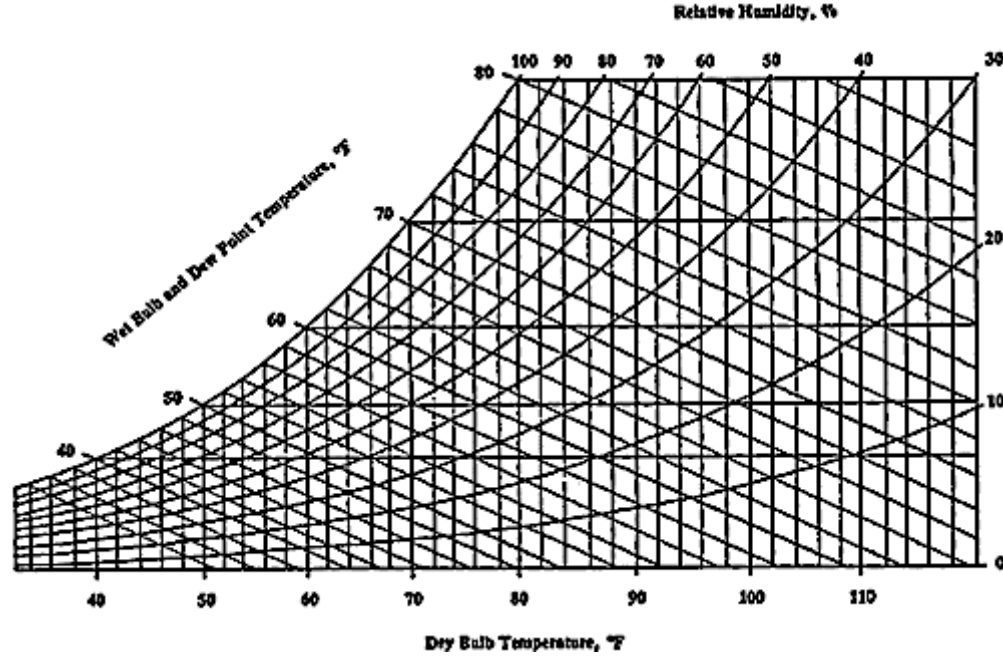

**Figure A1. Simplified psychrometric chart for temperatures and relative humidities.**

At first glance, even a simple psychrometric chart appears complex (*Figure A1*). However, separating the various lines and scales on the chart simplifies understanding their location, meaning and use.

### ***Air Temperature***

Air temperature is a measure of the heat content of air. Three different temperature measurements are used in the psychrometric chart:

1. **Dry bulb temperature** is the air temperature determined by an ordinary thermometer. Dry bulb temperature is given in weather reports. The dry bulb temperature scale is located at the base of the chart. Vertical lines indicate constant dry bulb temperature (*Figure A2*).

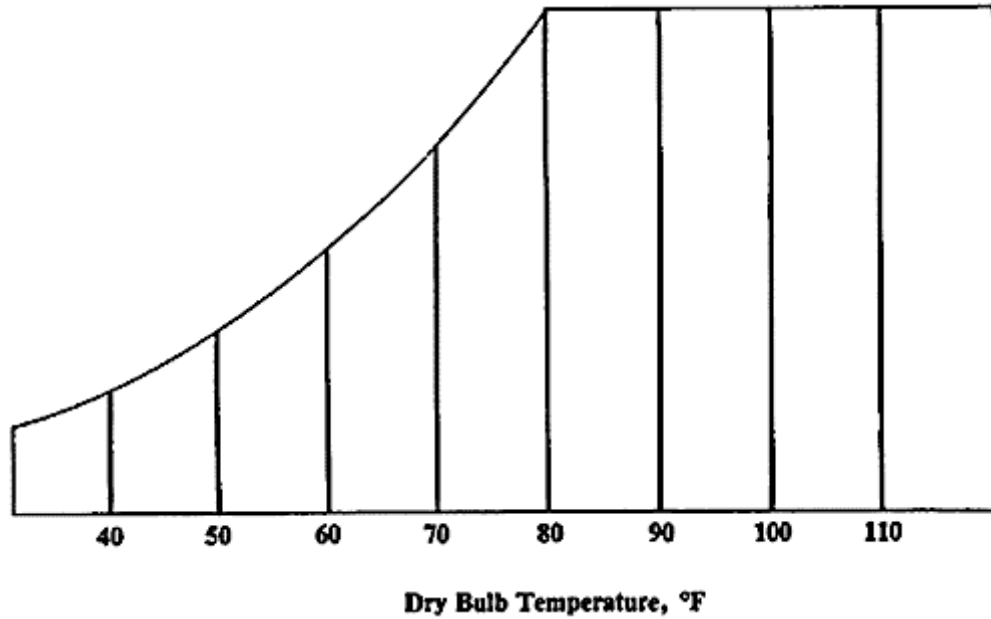

Figure A2. Dry bulb temperature lines.

2. **Wet bulb temperature** reflects the cooling effect of evaporating water. This effect is often used to cool livestock buildings and some homes. Wet bulb temperature can be determined by passing air over a thermometer that has been wrapped with a small amount of moist cloth. The cooling effect of the evaporating water causes a lower temperature compared to the dry bulb air temperature. The wet bulb temperature scale is located along the curved upper left portion of the chart. The sloping lines indicate equal wet bulb temperatures (Figure A3).

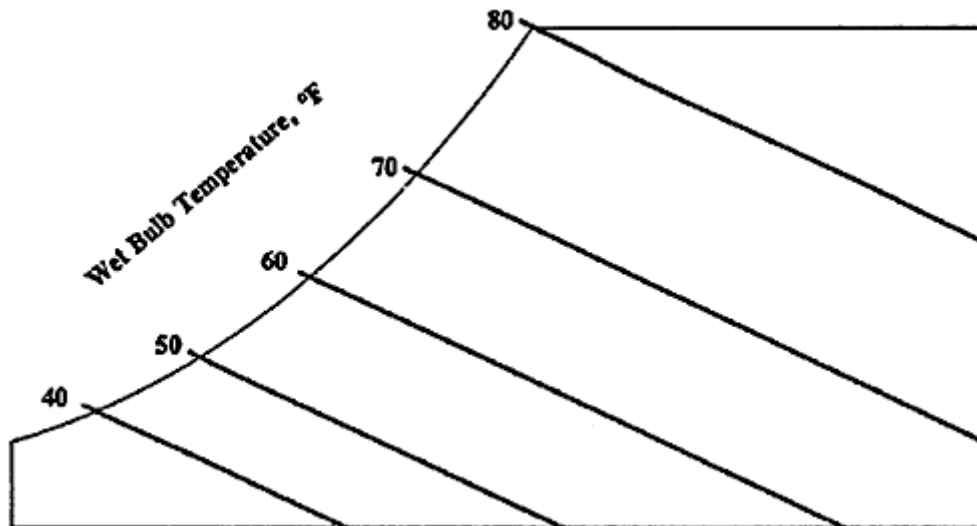
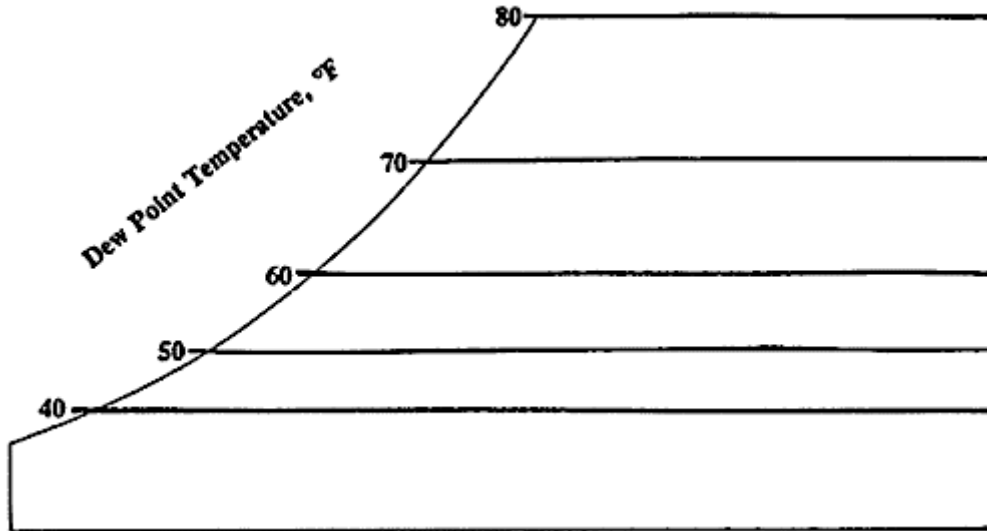

Figure A3. Wet bulb temperature lines.

3. **Dew point temperature** is the temperature below which moisture will condense out of air. Air that is holding as much water vapor as possible is saturated or at its dew point.



Water will condense on a surface, such as a building wall or pitcher of ice water, that is at or below the dew point temperature of the air. The dew point temperature scale is located along the same curved portion of the chart as the wet bulb temperature scale. However, horizontal lines indicate equal dew point temperatures (*Figure A4*).



**Figure A4. Dewpoint temperature lines.**

**Relative Humidity**

As the name implies, relative humidity is a measure of how much moisture is present compared to how much moisture the air could hold at that temperature. Relative humidity, which is expressed as a percent, is given in weather reports. Lines representing conditions of equal relative humidities sweep from the lower left to the upper right of the psychrometric chart. The 100 percent relative humidity (saturation) line corresponds to the wet bulb and the dew point temperature scale line. The line for zero percent relative humidity falls along the dry bulb temperature scale line (*Figure A5*).

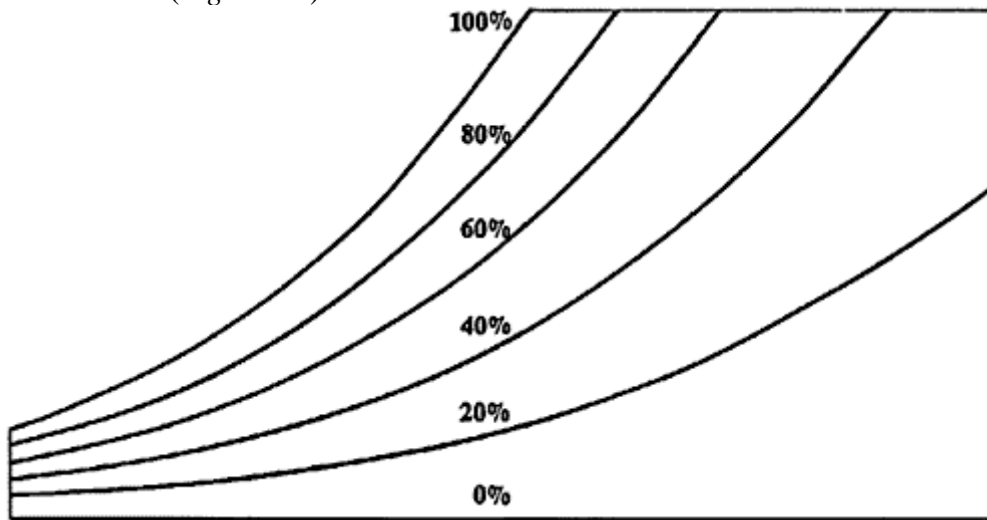

**Figure A5. Relative humidity lines.**

The versatility of the psychrometric chart lies in the fact that by knowing just two properties of moist air, the other properties can be determined. The following example will help to show how the chart is used.

Moist air is at 80°F (dry bulb) and 50 percent relative humidity. What are the other properties of this air?

*Answer:* First locate the intersection of the 80°F dry bulb temperature line and the 50 percent relative humidity line. From this intersection, follow the appropriate lines to the correct scales (Figure A6). Table A1 lists the determined properties.

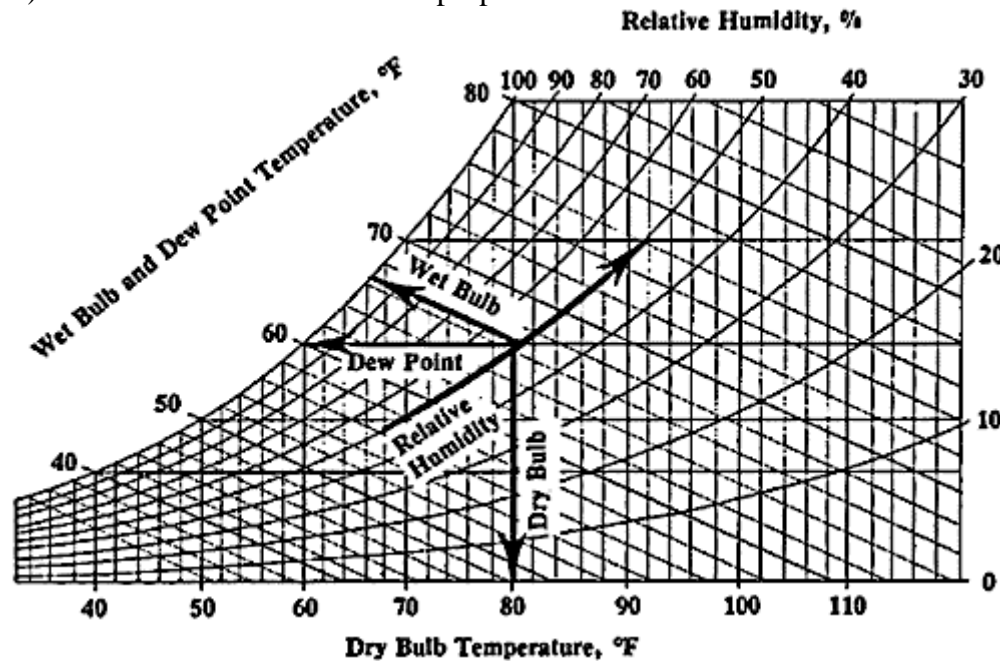

Figure A6. Location of properties

Table A1. Summary of air properties for Example 1.

Property	Value
Dry bulb temperature (given)	80°F
Relative humidity (given)	50%
Wet bulb temperature	67°F
Dew point temperature	59°F

The Distributed Energy Program would like to acknowledge Oak Ridge National Laboratory for its Technical Project Input to this Report.

## OAK RIDGE NATIONAL LABORATORY

MANAGED BY UT-BATTELLE FOR THE DEPARTMENT OF ENERGY



### **A Strong Energy Portfolio for a Strong America**

Energy efficiency and clean, renewable energy will mean a stronger economy, a cleaner environment, and greater energy independence for America. Working with a wide array of state, community, industry, and university partners, the U.S. Department of Energy's Office of Energy Efficiency and Renewable Energy invests in a diverse portfolio of energy technologies.

#### **For more information contact:**

EERE Information Center

1-877-EERE-INF (1-877-337-3463)

[www.eere.energy.gov](http://www.eere.energy.gov)