



Tres Amigas Superstation: Opportunity, Technology, Challenges

U.S. DOE Applications for High-Voltage Direct
Current Transmission Technologies Workshop

April 22, 2013
Arlington, VA

*Smarter, cleaner
... better energy*



Project Value Creation



Connects the three US asynchronous power grids through a DC hub that can regulate the direction and level of power flows between the grids

Provides economic incentives to further drive the growth of the nation's renewable resources

Optimizes the value of existing and planned AC and DC/ HTS infrastructure

Provides open-access and cost-effective transmission services consistent with NERC standards and regional reliability requirements

Provides voltage support, capacity firming and other value-added and ancillary services

Scope of the Business

The Tres Amigas Transmission Superstation can be mapped against the NIST Smart Grid Conceptual Model to illustrate the scope of the Tres Amigas business.

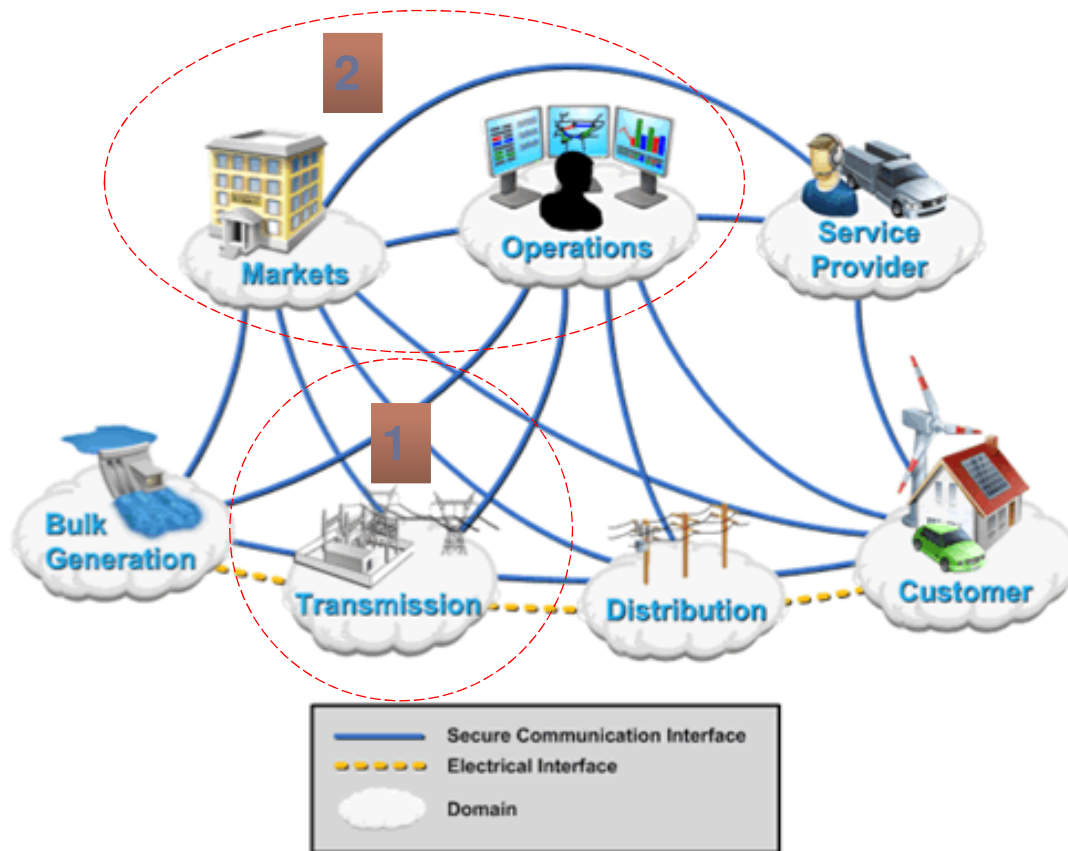

1 Transmission: The fundamental offering of Tres Amigas is transmission service. From this base it is possible to offer other services, both to support stable system operations, in the interconnected grids, and to facilitate commercial transactions.

2 Operations: Tres Amigas Operations will serve as the hub for both the transmission operator and market/exchange services. It will ensure reliability and interchange coordination, and it will carry out a number of core market functions necessary to support robust markets

Source: The National Institute of Standards and Technology (NIST) Smart Grid Conceptual Model

The Location: Regional Renewable Resource Potential

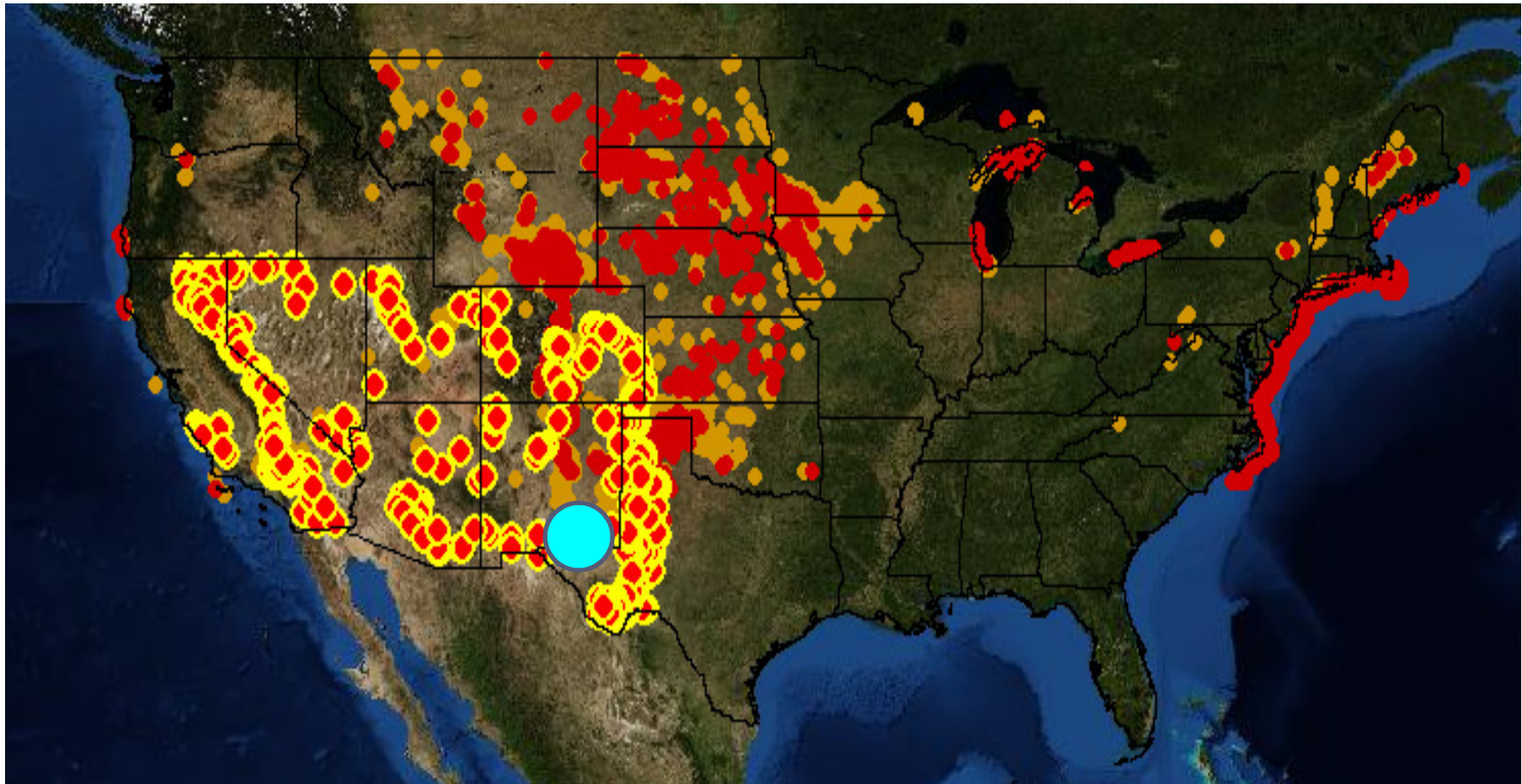

From the 2010 Transmission Summit in Sweetwater

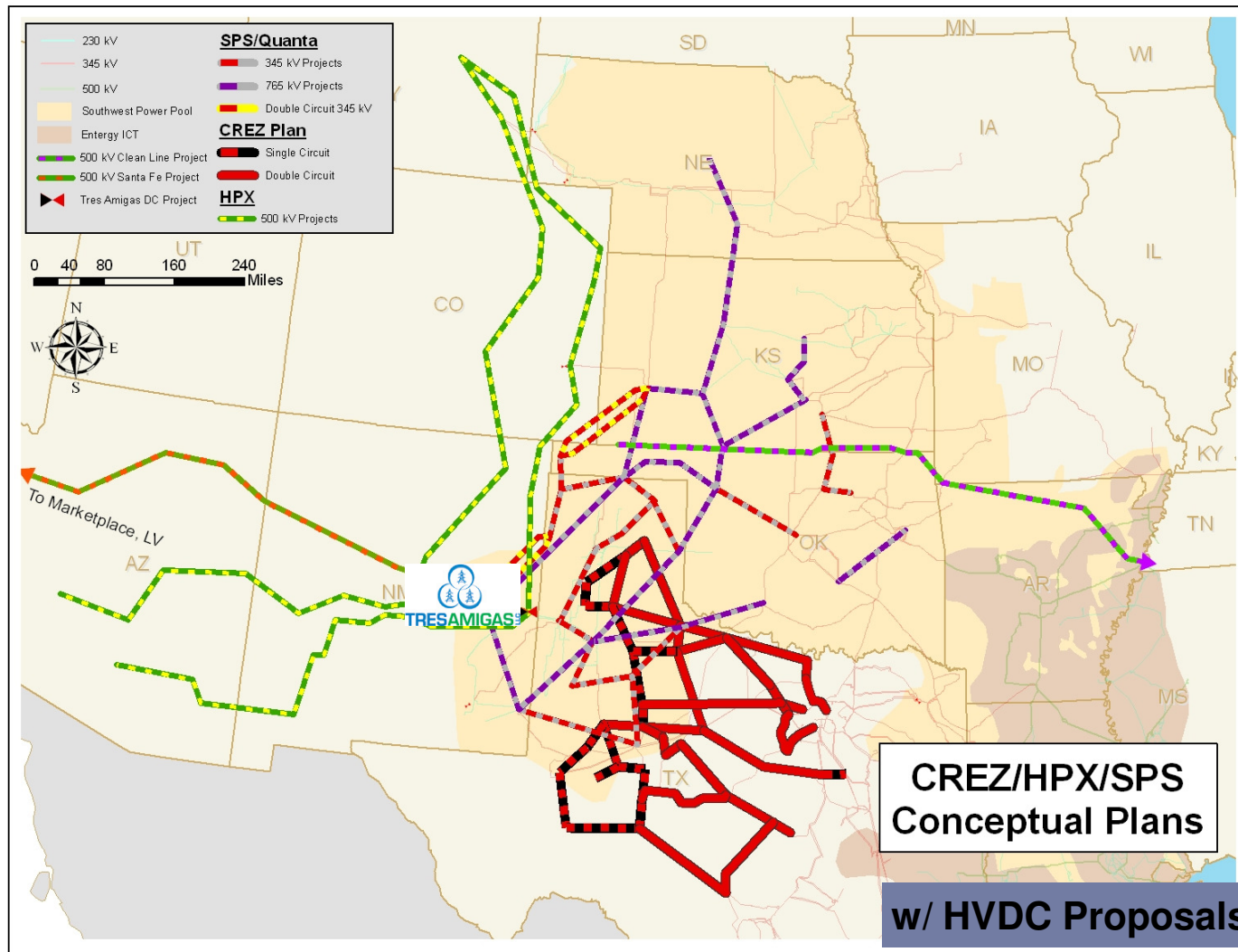

Site Location in New Mexico

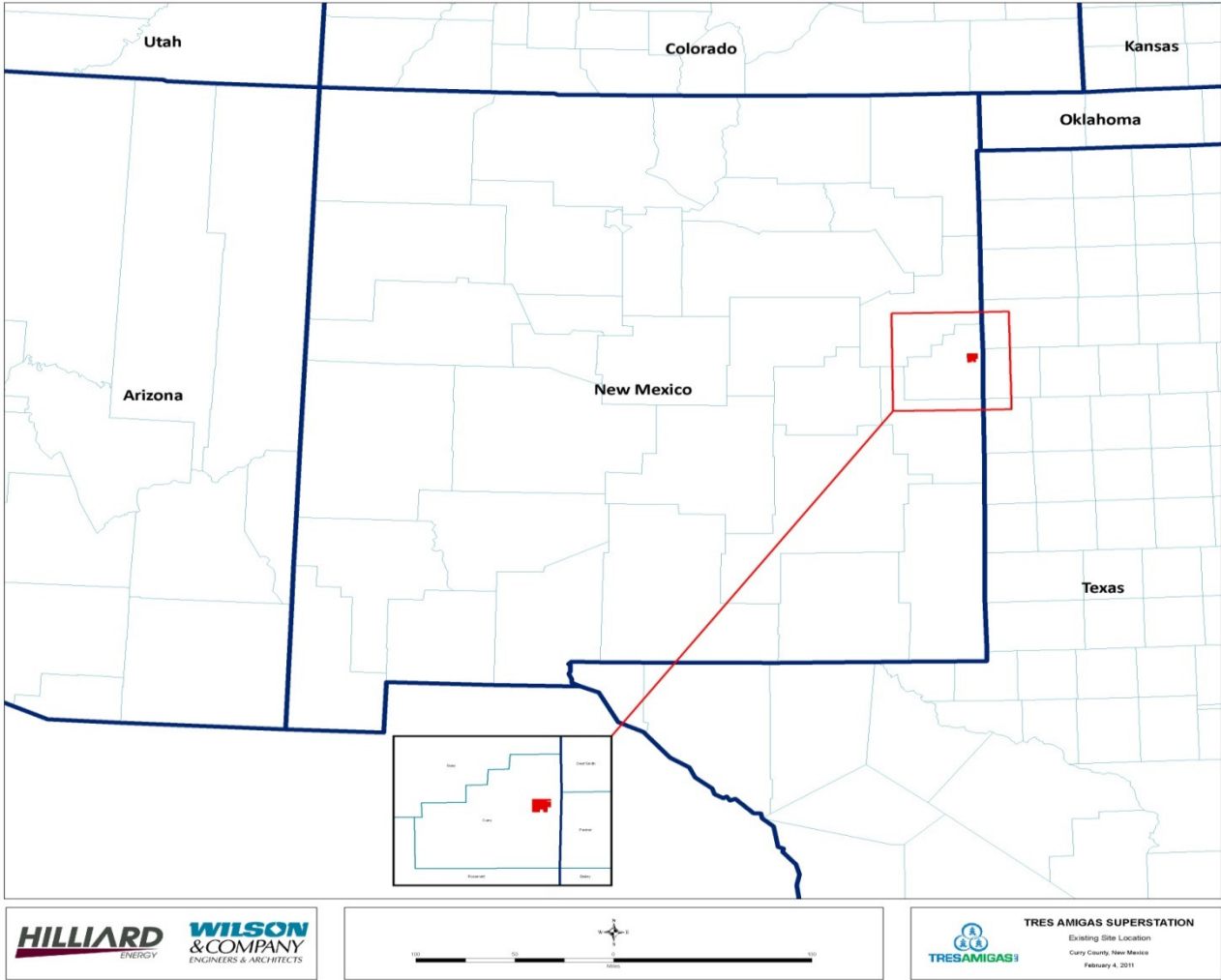

First Phase Scope of Construction

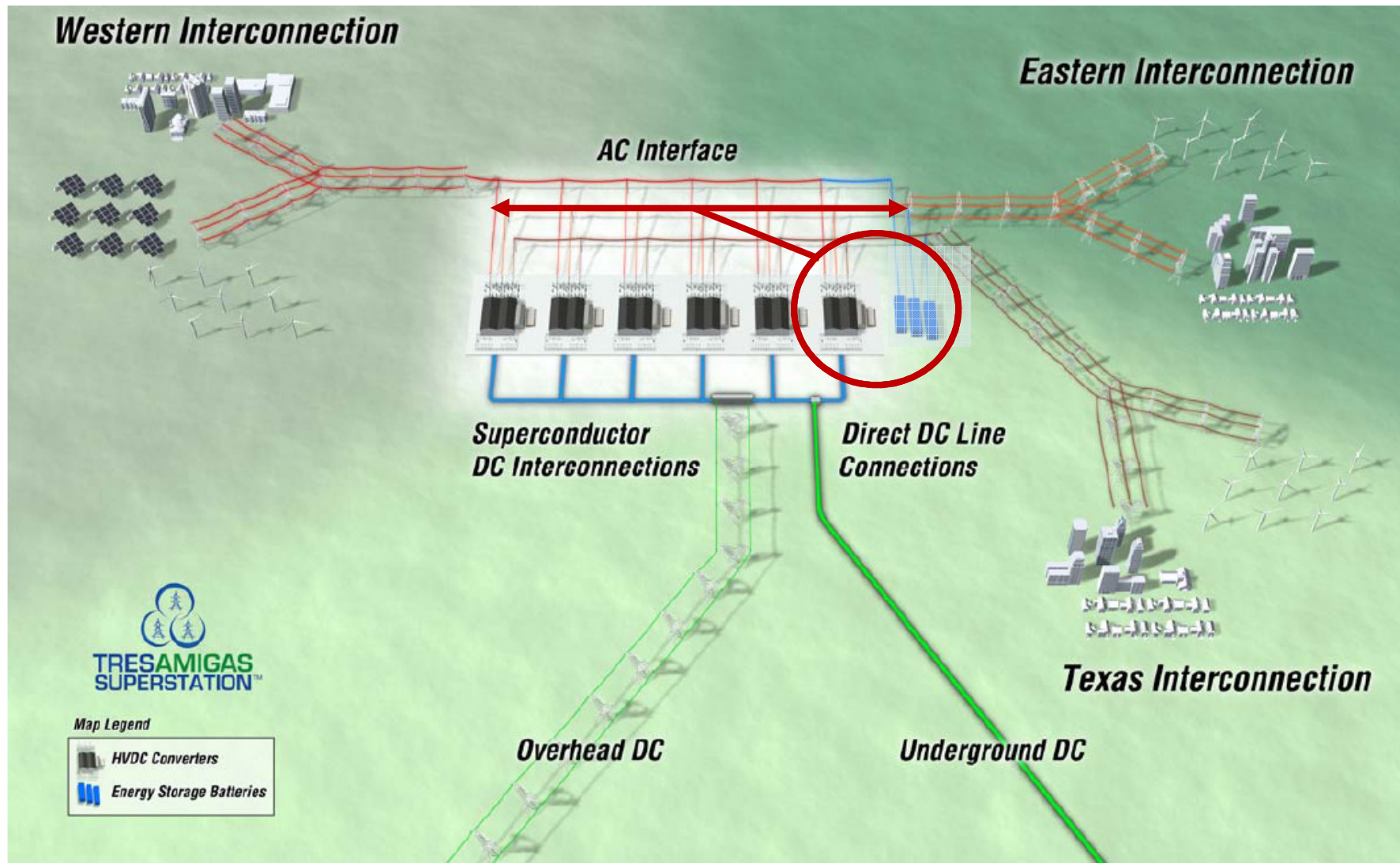

Alstom Grid HVDC MaxSine Technology

- **Voltage Sourced Converter (VSC) technology**
- **Modular multi-level converter design**
- **Control of real and reactive power flow into AC grids**
- **Harmonic free output voltage**
Ideal for use on weak AC grids

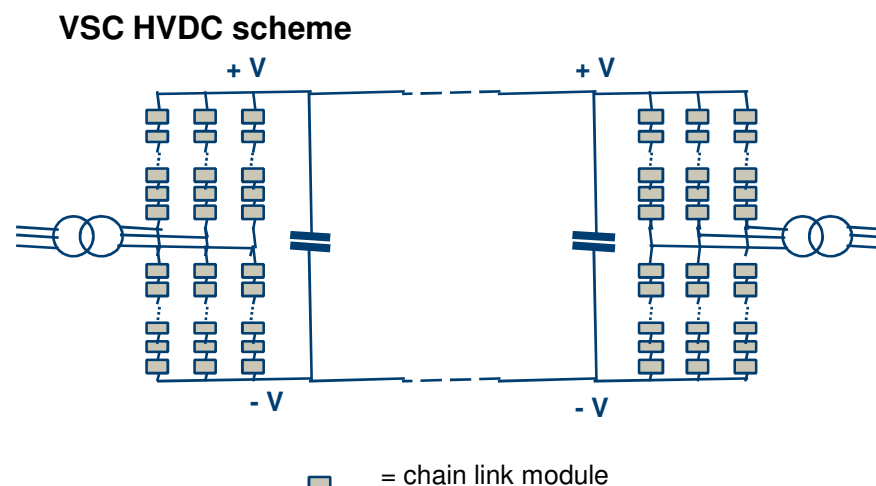



Folded Back-to-Back Converter Layout

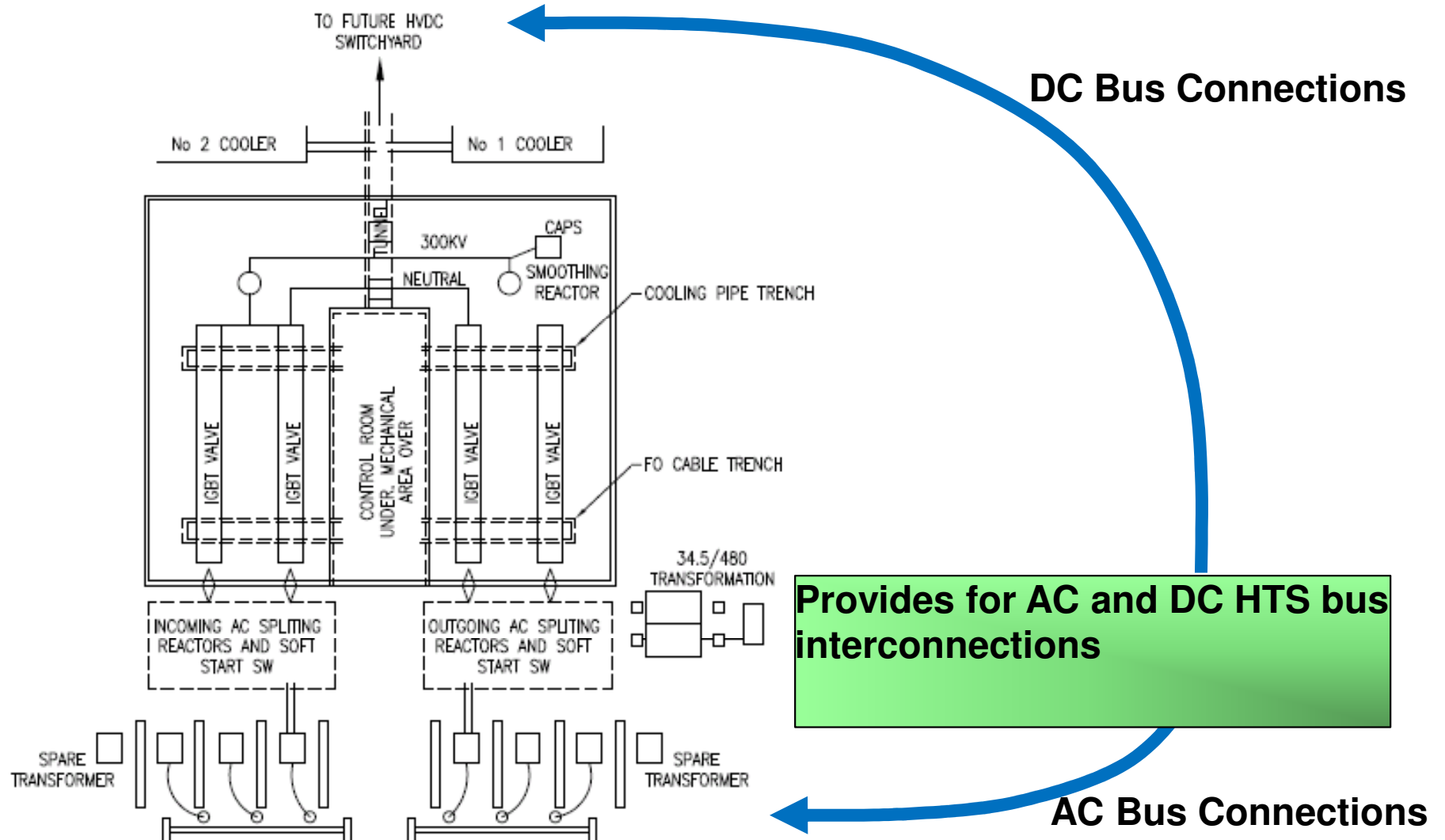

Tres Amigas Conceptual Build Out-Detail

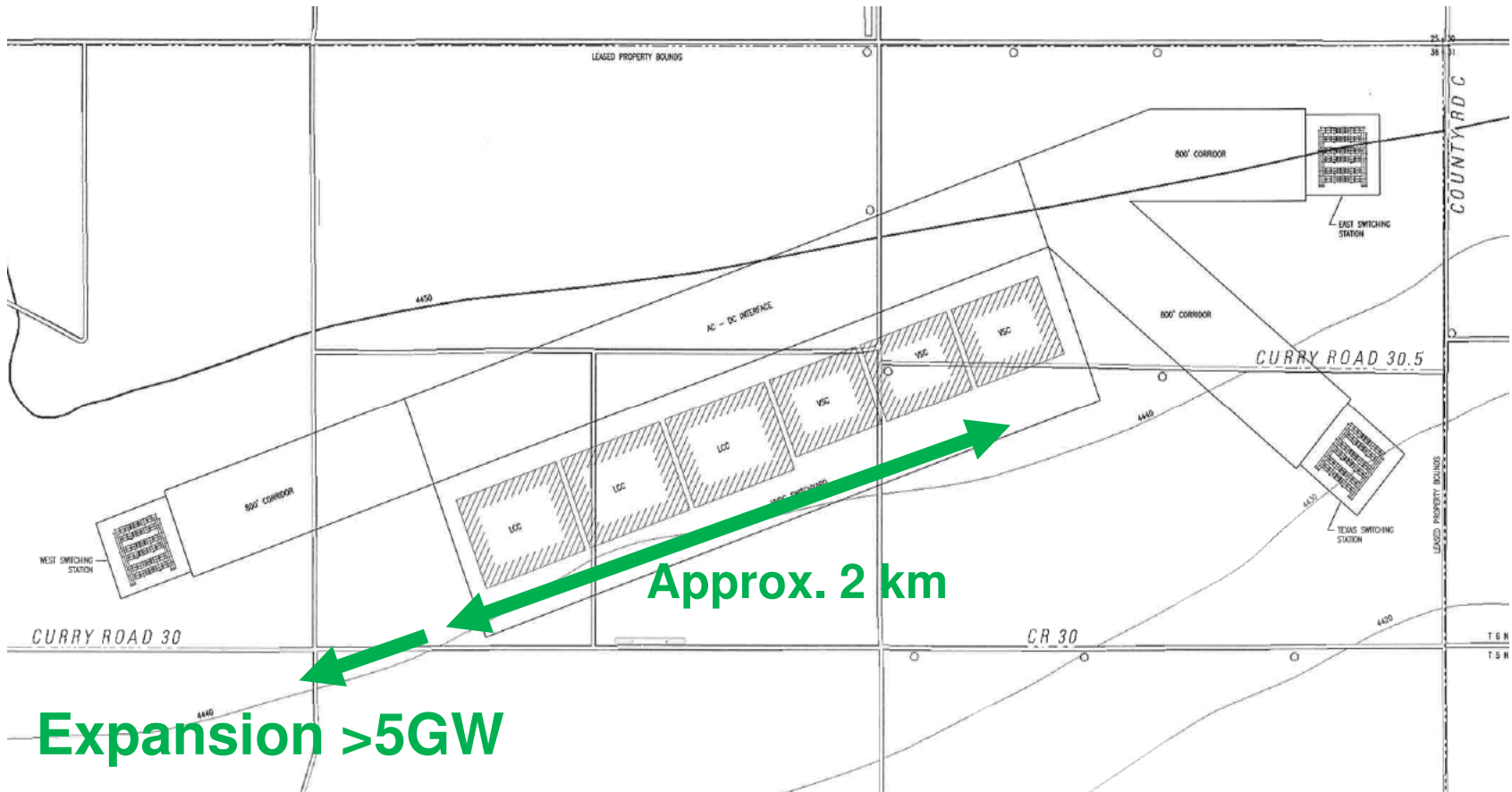

Full 5GW build out allows for high current DC bus

Why Superconductor HVDC Bus/Cable?

A unique option for high current DC

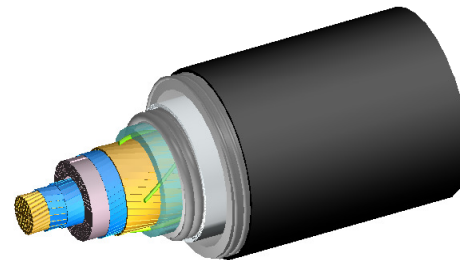
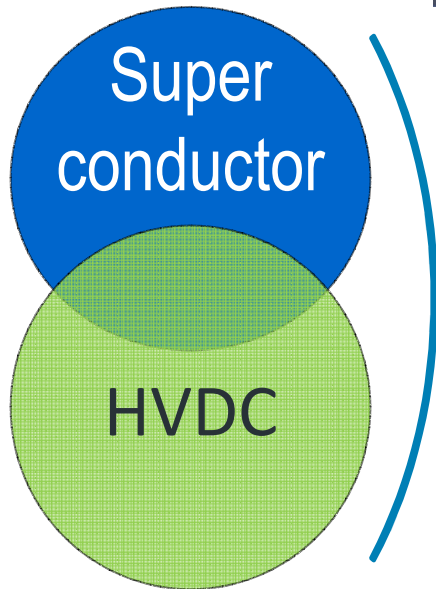
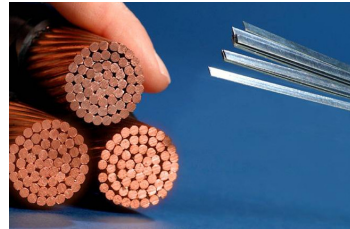

Superconductor DC cables can carry 1000's or 10,000's Amps with no losses

- Effectively Unlimited Power Capacity
- Only one circuit required
- Highly Efficient
- Cost Competitive
- Underground and Easy to Site

China: Current HVDC National Grid Plan

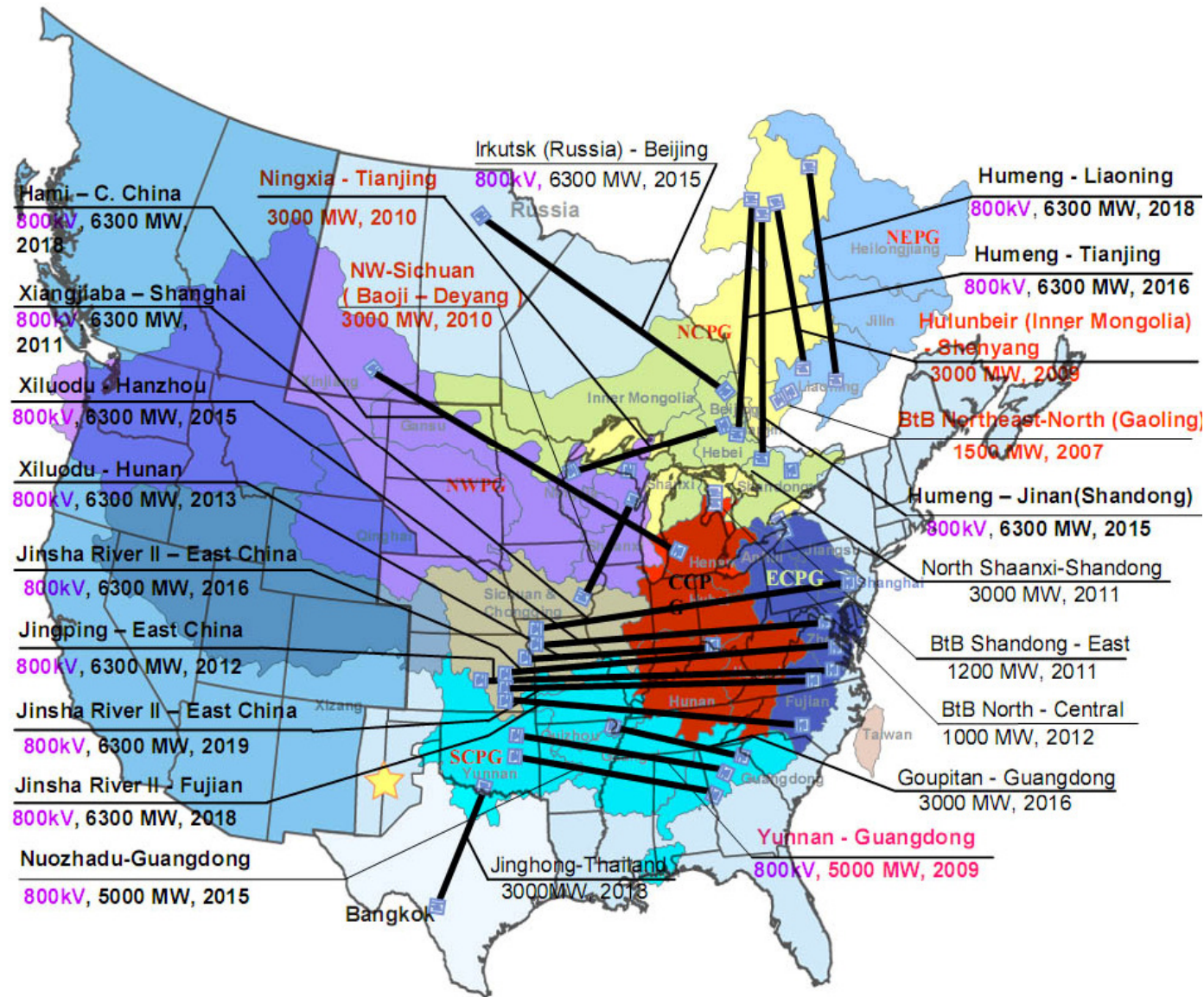

Europe: Extended Grid Plan

- From Iceland (Northwest) to Israel (Southeast) = 3,200 mi
- Concept of grid is 25,000 miles of line

- Solar Power
 - Wind Power
 - Geothermal
 - Hydro
 - Biomass
- Connections already in place or planned
- Vision of ABB and DLR

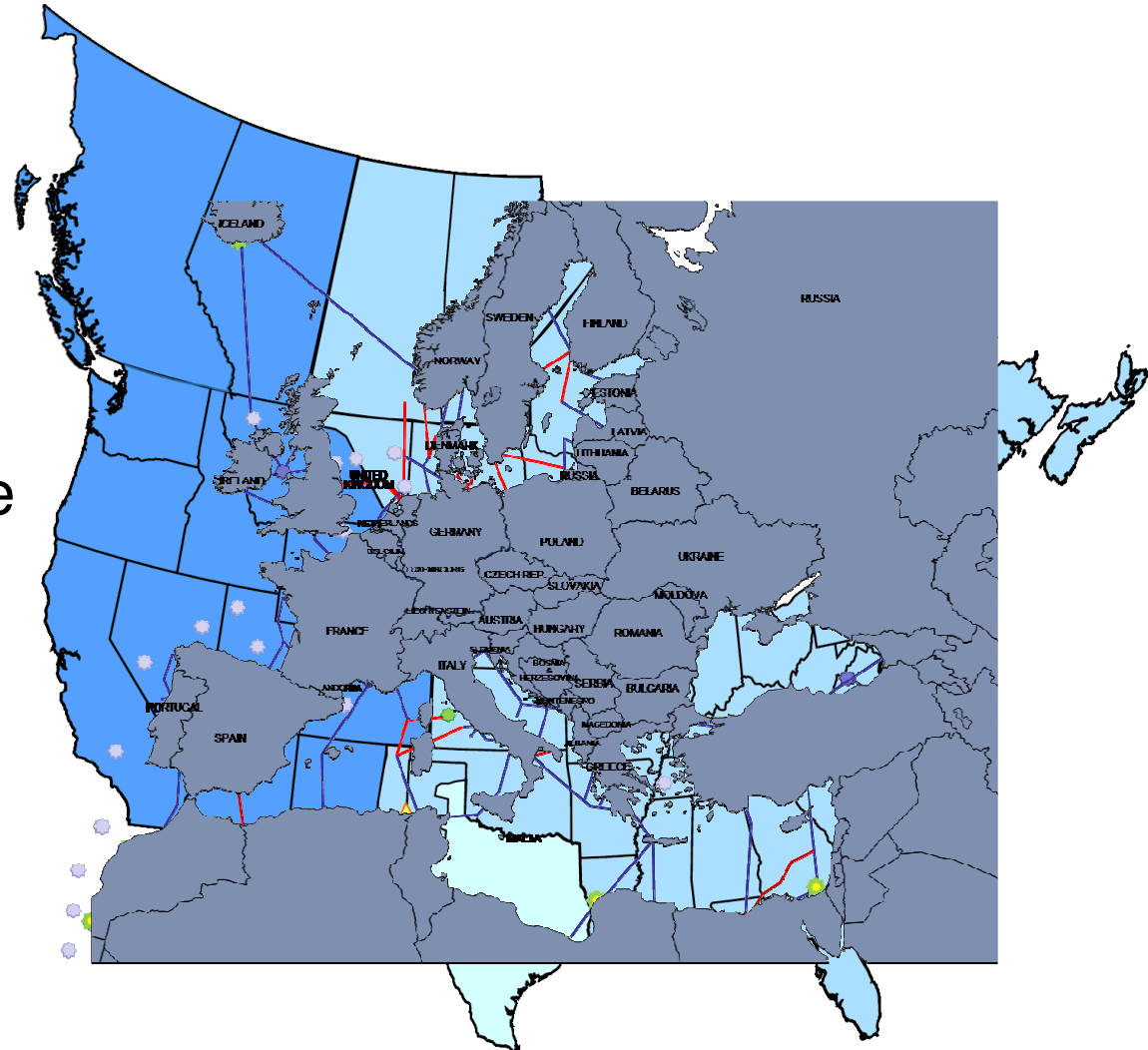

The new high-voltage network would range from the Sahara to the polar cap. The concept calls for main lines that are 40,000 kilometers long. And parts of it already exist.



Friends of the Super Grid Quote:

•“The full significance of a switchable HVDC innovation has not yet been appreciated by policy makers or by the business community. It is clear that a network incorporating a HVDC grid with the redundancy and reliability of current AC grids is now a reality and that the limits of what is technologically possible have been greatly expanded.”

•“HVDC technology will open markets, strengthen security of supply and create another global opportunity for European companies to export sustainable energy technology. The technology underpinning the Supergrid will give competitive advantage to the companies involved with its specification and design. This type of integrated AC/DC grid will be a template for what will be needed in other global markets including the US and China.”

Hurdles to a National HVDC Grid Overlay



True widespread deployment of HVDC in the US requires development of a national HVDC grid overlay.

3 Key Hurdles

1. No effective way to study the issue
 - No practical way to develop a national overlay within the confines of existing incumbent entities
 2. Any work that is done reinforces the status quo
 3. Difficulties in financing; No customer rate base can be developed that will pay for anything
 - Why should I allow this in my State?
 - Why should the citizens of my State pay for a pass-through line
 - Why should my ratepayers pay for a line that doesn't benefit them/us
 - Etc?
-

Why has TASS Succeeded?



Unique

- TASS location and function is exception than rule

Needed

- Necessary for universal power exchange

Private

- All private funding
- Not possible otherwise

Revenue

- Uniquely allows revenue without rate base
-

Funding – Tres Amigas Merchant Transmission



Unlike traditional transmission facilities, merchant transmission project owners assume all market risk. Tres Amigas has been successful in receiving significant capital through investors and private placements.

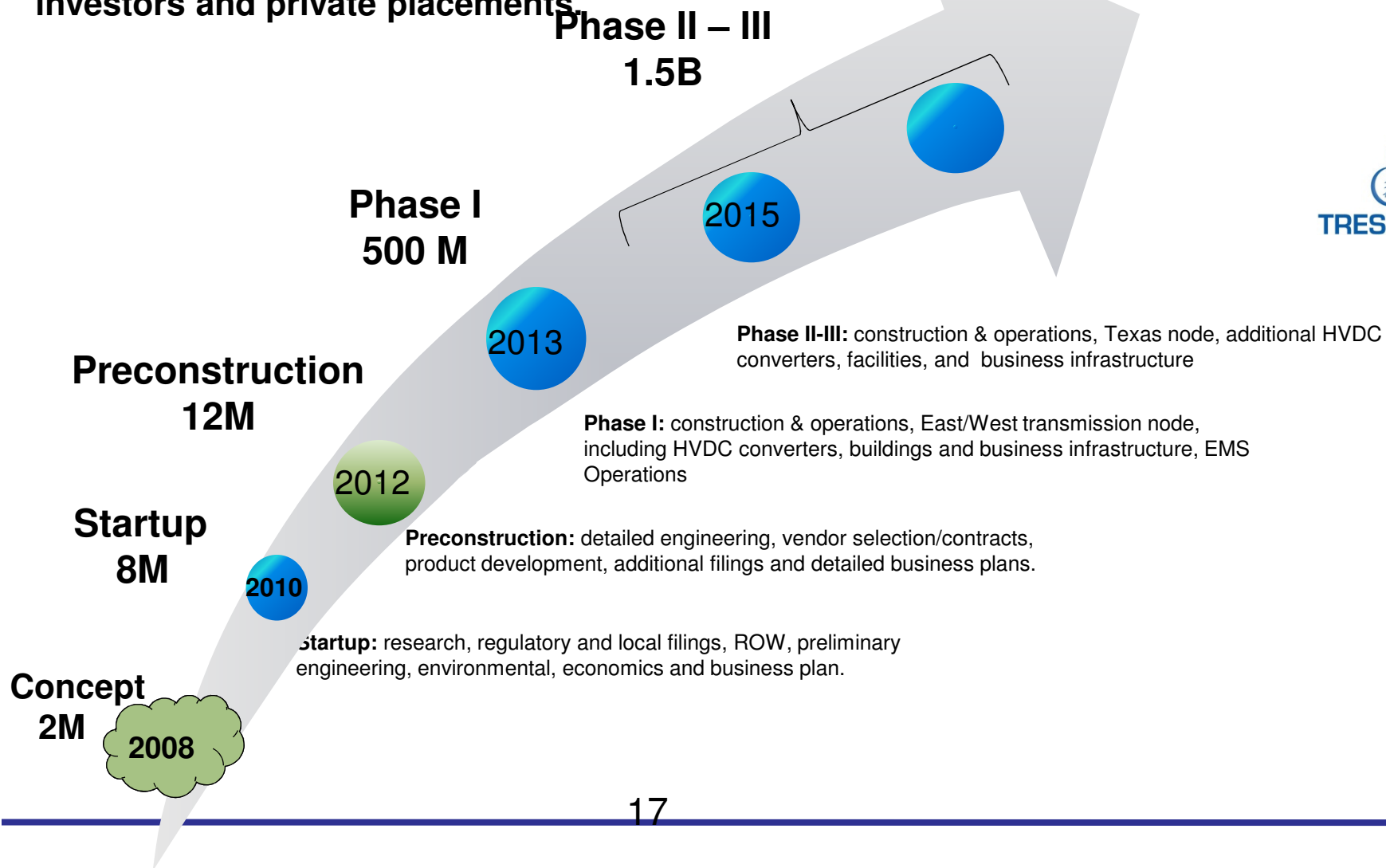

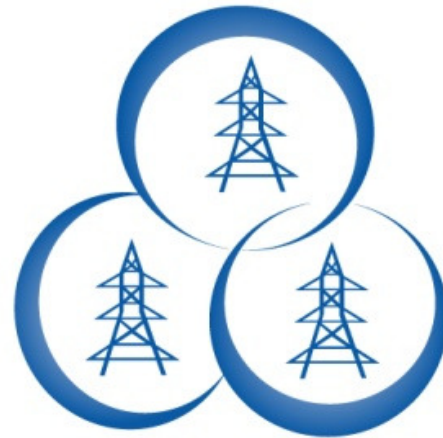

TRESAMIGAS ^{LLC}

Tres Amigas SuperStation....

Uniting the Electric Grid