

This document, concerning Walk-in Coolers and Walk-in Freezers is an action issued by the Department of Energy. Though it is not intended or expected, should any discrepancy occur between the document posted here and the document published in the Federal Register, the Federal Register publication controls. This document is being made available through the Internet solely as a means to facilitate the public's access to this document.

[6450-01-P]

**DEPARTMENT OF ENERGY**

[Case Number 2022-004; EERE-2022-BT-WAV-0010]

**Energy Conservation Program: Decision and Order Granting a Waiver to Norlake, Inc., dba Refrigerated Solutions Group, from the Department of Energy Walk-in Coolers and Walk-in Freezers Test Procedure**

**AGENCY:** Office of Energy Efficiency and Renewable Energy, Department of Energy.

**ACTION:** Notification of decision and order.

**SUMMARY:** The U.S. Department of Energy (“DOE”) gives notification of a Decision and Order (Case Number 2022-004) that grants to Norlake, Inc., dba Refrigerated Solutions Group (“RSG”) a waiver from specified portions of the DOE test procedure for determining the energy efficiency of specified walk-in cooler refrigeration systems. Under the Decision and Order, RSG is required to test and rate the specified basic models of its equipment in accordance with the alternate test procedure set forth in the Decision and Order.

**DATES:** The Decision and Order is effective on **[INSERT DATE OF PUBLICATION IN THE *FEDERAL REGISTER*]**. The Decision and Order will terminate upon the date on which use of the test procedure for walk-in coolers and walk-in freezers located at title 10 of the Code of Federal Regulations (“CFR”), part 431, subpart R, appendix C1 is required to determine compliance with energy conservation standards. At such time, RSG must use the relevant test procedure for this equipment for any testing to demonstrate compliance with the applicable standards, and any other representations of energy use.

**FOR FURTHER INFORMATION CONTACT:**

Ms. Julia Hegarty, U.S. Department of Energy, Office of Energy Efficiency and Renewable Energy, Building Technologies Office, Mailstop EE-5B, 1000 Independence Avenue, SW., Washington, DC 20585-0121. E-mail: *AS\_Waiver\_Request@ee.doe.gov*.

Mr. Matthew Schneider, U.S. Department of Energy, Office of the General Counsel, GC-33, 1000 Independence Avenue, SW., Washington, DC, 20585-0121. Telephone: (240) 597-6265. Email: *matthew.schneider@hq.doe.gov*.

**SUPPLEMENTARY INFORMATION:**

In accordance with 10 CFR 431.401(f)(2), DOE gives notification of the issuance of its Decision and Order as set forth below. The Decision and Order grants RSG a waiver from the applicable test procedure at 10 CFR part 431, subpart R, appendix C for the specified basic models for which RSG petitioned for waiver and provides that RSG must test and rate such equipment using the alternate test procedure specified in the Decision and Order. RSG's representations concerning the energy efficiency of the specified basic models must be based on testing according to the provisions and restrictions in the alternate test procedure set forth in the Decision and Order, and the representations must fairly disclose the test results. Distributors, retailers, and private labelers are held to the same requirements when making representations regarding the energy efficiency of this equipment. (42 U.S.C. 6314(d))

Any manufacturer of a basic model employing a technology or characteristic for which a waiver was granted for another basic model and that results in the need for a waiver (as specified by DOE in a published decision and order in the *Federal Register*) must petition and be granted a

waiver for that basic model. (10 CFR 431.401(j)) Manufacturers may also submit a request for interim waiver pursuant to the requirements of 10 CFR 431.401.

**Case # 2022-004**  
**Decision and Order**

**I. Background and Authority**

The Energy Policy and Conservation Act, as amended (“EPCA”),<sup>1</sup> authorizes the U.S. Department of Energy (“DOE”) to regulate the energy efficiency of a number of consumer products and certain industrial equipment. (42 U.S.C. 6291–6317) Title III, Part C<sup>2</sup> of EPCA established the Energy Conservation Program for Certain Industrial Equipment, which sets forth a variety of provisions designed to improve the energy efficiency for certain types of industrial equipment. This equipment includes walk-in coolers and walk-in freezers (collectively, “walk-ins”), the focus of this document. (42 U.S.C. 6311(1)(G))

The energy conservation program under EPCA consists essentially of four parts: (1) testing, (2) labeling, (3) Federal energy conservation standards, and (4) certification and enforcement procedures. Relevant provisions of EPCA include definitions (42 U.S.C. 6311), energy conservation standards (42 U.S.C. 6313), test procedures (42 U.S.C. 6314), labeling provisions (42 U.S.C. 6315), and the authority to require information and reports from manufacturers (42 U.S.C. 6316; 42 U.S.C. 6299).

The Federal testing requirements consist of test procedures that manufacturers of covered equipment must use as the basis for: (1) certifying to DOE that their equipment complies with the applicable energy conservation standards adopted pursuant to EPCA (42 U.S.C. 6316(a); 42

---

<sup>1</sup> All references to EPCA in this document refer to the statute as amended through the Energy Act of 2020, Public Law 116-260 (Dec. 27, 2020), which reflect the last statutory amendments that impact Parts A and A-1 of EPCA.

<sup>2</sup> For editorial reasons, upon codification in the U.S. Code, Part C was redesignated as Part A-1.

U.S.C. 6295(s)), and (2) making representations about the efficiency of that equipment (42 U.S.C. 6314(d)). Similarly, DOE must use these test procedures to determine whether the equipment complies with relevant standards promulgated under EPCA. (42 U.S.C. 6316(a); 42 U.S.C. 6295(s))

Under 42 U.S.C. 6314, EPCA sets forth the criteria and procedures DOE is required to follow when prescribing or amending test procedures for covered equipment. EPCA requires that any test procedures prescribed or amended under this section must be reasonably designed to produce test results which reflect energy efficiency, energy use or estimated annual operating cost of covered equipment during a representative average use cycle and requires that test procedures not be unduly burdensome to conduct. (42 U.S.C.6314(a)(2)) The test procedures for walk-in refrigeration systems are set forth at 10 CFR part 431, subpart R, appendix C, *Uniform Test Method for the Measurement of Net Capacity and AWEF of Walk-in Cooler and Walk-in Freezer Refrigeration Systems* (“appendix C”) and appendix C1, *Uniform Test Method for the Measurement of Net Capacity and AWEF<sup>2</sup> of Walk-In Cooler and Walk-In Freezer Refrigeration Systems* (“appendix C1”).<sup>3</sup>

Any interested person may submit a petition for waiver from DOE’s test procedure requirements. 10 CFR 431.401(a)(1). DOE will grant a waiver from the test procedure requirements if DOE determines either that the basic model for which the waiver was requested

---

<sup>3</sup> Appendix C is the test procedure currently required for walk-in refrigeration systems to demonstrate compliance with energy conservation standards. Use of appendix C1 will be required beginning on the compliance date of any amended energy conservation standards for walk-ins published after January 1, 2022. DOE has established separate test procedures for walk-in envelope components at 10 CFR part 431, subpart R, appendices A and B. Appendix A is used for testing the energy use of walk-in display panels, display doors, and non-display doors; appendix B is used for testing insulation R-value of non-display panels and non-display doors.

contains a design characteristic that prevents testing of the basic model according to the prescribed test procedures, or that the prescribed test procedures evaluate the basic model in a manner so unrepresentative of its true energy consumption characteristics as to provide materially inaccurate comparative data. 10 CFR 431.401(f)(2). In granting a waiver or interim waiver, DOE will not change the energy use or efficiency metric that the manufacturer must use to certify compliance with the applicable energy conservation standard and to make representations about the energy use or efficiency of the covered equipment. 10 CFR 431.401(a). DOE may grant the waiver subject to conditions, including adherence to alternate test procedures. 10 CFR 431.401(f).

As soon as practicable after the granting of any waiver, DOE will publish in the *Federal Register* a notice of proposed rulemaking to amend its regulations so as to eliminate any need for the continuation of such waiver. 10 CFR 431.401(l). As soon thereafter as practicable, DOE will publish in the *Federal Register* a final rule to that effect. *Id.* When DOE amends the test procedure to address the issues presented in a waiver, the waiver will automatically terminate on the date on which use of that test procedure is required to demonstrate compliance. 10 CFR 431.401(h)(3).

## **II. RSG's Petition for Waiver: Assertions and Determinations**

On February 17, 2022, DOE received from RSG a petition for waiver and interim waiver from the DOE test procedure for walk-in refrigeration systems set forth at 10 CFR part 431,

subpart R, appendix C. (RSG, No. 1, attachment 1, at pp. 1-3<sup>4</sup>) Pursuant to 10 CFR 431.401(e)(i), DOE posted the petition on the DOE website. The petition did not identify any of the information contained therein as confidential business information.

DOE's currently applicable test procedure for walk-in refrigeration systems (*i.e.*, appendix C) incorporates by reference Air-Conditioning, Heating, and Refrigeration Institute ("AHRI") Standard 1250-2009, *2009 Standard for Performance Rating of Walk-In Coolers and Freezers* ("AHRI 1250-2009"); AHRI Standard 420-2008, *Performance Rating of Forced-Circulation Free-Delivery Unit Coolers for Refrigeration* ("AHRI 420-2008"); and American Society of Heating, Refrigerating, and Air-Conditioning Engineers ("ASHRAE") Standard 23.1-2010, *Methods of Testing for Rating the Performance of Positive Displacement Refrigerant Compressors and Condensing Units that Operate at Subcritical Temperatures of the Refrigerant* ("ASHRAE 23.1-2010"). AHRI 1250-2009 is the industry test standard for refrigeration systems for walk-in coolers and freezers, including unit coolers and dedicated condensing units sold separately, as well as matched pairs. The procedure describes the method for measuring the refrigeration capacity and the electrical energy consumption for walk-in refrigeration systems. Using the refrigeration capacity and electrical energy consumption, AHRI 1250-2009 provides a calculation methodology to compute AWEF, the applicable energy-performance metric for refrigeration systems.

---

<sup>4</sup> A notation in this form provides a reference for information that is in the docket for this test procedure waiver (Docket No. EERE-2022-BT-WAV-0010) (available at [www.regulations.gov/document/EERE-2022-BT-WAV-0010](http://www.regulations.gov/document/EERE-2022-BT-WAV-0010)). This notation indicates that the statement preceding the reference is from document number 1 in the docket and appears at pages 1-3 of attachment 1 of that document. There are two attachments to document 1 of this docket. Attachment 1 is titled "DOE Waiver 021722". Attachment 2 is titled "RSG DOE Single Package System Alternate Test Procedure 021522".

In its petition for waiver and interim waiver, RSG presented several ways in which the currently prescribed test procedure would evaluate the specified basic models in a manner so unrepresentative of their true energy consumption as to provide materially inaccurate comparative data. These issues are summarized below.

First, as presented in RSG's petition, the specified basic models of walk-in refrigeration systems are single-packaged dedicated systems that contain multiple refrigeration circuits that operate using a single power feed. (RSG, No. 1, attachment 1, at p. 1) RSG claimed that the specified basic models meet the definition of a single-packaged dedicated system. *Id.* DOE defines a single-packaged dedicated system as "a single-package assembly that includes one or more compressors, a condenser, a means for forced circulation of refrigerated air, and elements by which heat is transferred from air to refrigerant, without any element external to the system imposing resistance to flow of the refrigerated air". *See* 10 CFR 431.302. As described by RSG, each refrigeration circuit in the specified basic models is made up of a compressor, expansion, device, condenser, and evaporator. (RSG, No. 1, attachment 1, at p. 1) The separate refrigeration circuits may share condenser fans, evaporator fans and a control system. *Id.* In its request for waiver and interim waiver, RSG stated that neither appendix C nor AHRI 1250-2009 provide a method for testing a single-packaged dedicated system with multiple refrigeration circuits. *Id.*

Second, RSG stated that the current test procedure requires that the unit under test be set up using a 25-foot line-set. *Id.* Section 3.3 of appendix C provides the test method for matched systems, single-packaged dedicated systems, and unit coolers tested alone, which references AHRI 1250-2009. Section C5 (Methods of Testing for Walk-In Cooler and Freezer Systems that

Have Matched Unit Coolers and Condensing Units) of AHRI 1250-2009 references test setup requirements that include the addition of a line-set that includes either one or two mass flow meters. Under section C5 of AHRI 1250-2009, the gross refrigeration capacity must be determined either by the dual instrumentation refrigerant enthalpy method (section C5.1.1 of AHRI 1250-2009, Method 1) or by the calibrated box method (section C5.1.2 of AHRI 1250-2009, Method 2). Both methods require installation of a refrigerant mass flow meter in the system's liquid line to determine the cooling capacity. Section C8.3 and Figure C1 of AHRI 1250-2009 specify the setup and measurements to be conducted for Method 1, for which 25-feet of additional refrigerant line is added to connect the condenser to the evaporator (unit cooler). Within this 25-foot line, two mass flow meters are incorporated, and the heat balance calculated from the two flow measurements must be within  $\pm 5$  percent. Section C9.2 and Figure C2 of AHRI 1250-2009 specify the setup and measurements for Method 2, in which 26-feet of additional refrigerant line is added to connect the condenser to the unit cooler (as for Method 1), incorporating one mass flow meter. Air-side gross refrigeration capacity and refrigerant-side gross refrigeration capacity are determined and must be equal to within  $\pm 5$  percent for the test to be considered valid. The 25 feet and 26 feet<sup>5</sup> of additional liquid line and suction line piping used to set up the test is termed a "line-set". In its petition for waiver and interim waiver, RSG stated that single-packaged dedicated systems are not intended to be remotely split via a line-set. (RSG, No. 1, attachment 1, at p. 1)

In its request for waiver and interim waiver, RSG noted that DOE has issued test procedure waivers for single-packaged dedicated refrigeration systems using air enthalpy test

---

<sup>5</sup> AHRI 1250-2009 does not explain why Method 1 requires 25 feet of refrigeration line and Method 2 requires 26 feet of refrigeration line during test set up.

methods. (RSG, No. 1, attachment 1, at p. 2) DOE granted a waiver to Store It Cold for basic models of single-packaged dedicated systems on August 9, 2019. 84 FR 39286. Store It Cold petitioned for a waiver after determining that the dual instrumentation refrigerant enthalpy method specified in AHRI 1250-2009 was not providing consistent capacity measurements for its single-packaged dedicated systems. 84 FR 39286, 39287. The alternate test procedure associated with this prior waiver required that the specified single-packaged dedicated system basic models shall be tested using the Indoor Air Enthalpy Method and the Outdoor Air Enthalpy Method in accordance with ASHRAE 37-2009, *Methods of Testing for Rating Electrically Driven Unitary Air-Conditioning and Heat-Pump Equipment* (“ASHRAE 37”). 84 FR 39286, 39292. DOE also granted waivers to Air Innovations, CellarPro, Vinotemp, and Vinotheque for walk-in refrigeration systems used in wine cellar applications, for which some of the basic models included in these waivers were single-packaged dedicated systems.<sup>6</sup> The alternate test methods included in these waivers require the specified basic models to be tested in accordance with AHRI Standard 1250-2020 (*2020 Standard for Performance Rating of Walk-In Coolers and Freezers*, “AHRI 1250-2020”), which references the air enthalpy methods in ASHRAE 37 for testing single-packaged dedicated systems.<sup>7</sup> Use of air enthalpy methods for testing a single-packaged dedicated system capture the impact of thermal loss and the infiltration of warm air into the evaporator portion of these systems, which increases the refrigerant load on the system. In its petition for waiver and interim waiver, RSG stated that its laboratory is not set up to conduct air enthalpy testing, and that it would require substantial time and expense to set up its

---

<sup>6</sup> See Waiver Decision and Orders for Air Innovations (86 FR 23702 (May 4, 2021)), CellarPro (86 FR 26496 (May 14, 2021)), Vinotheque (86 FR 26504 (May 14, 2021)), and Vinotemp (86 FR 36732 (Jul. 13, 2021)).

<sup>7</sup> Subsequent to DOE’s grant of waiver to Store It Cold, AHRI published an updated version of AHRI 1250 (*i.e.*, AHRI 1250-2020) that provides testing provisions for single-packaged dedicated systems that incorporate by reference the approach used in ASHRAE 37 with some modification.

laboratory to conduct air enthalpy testing. (RSG, No. 1, attachment 1, at p. 2) Additionally, RSG explained that it contacted third-party labs to inquire about testing single-packaged dedicated systems using the air enthalpy method, but these labs responded that they are not currently able to conduct air enthalpy testing. *Id.*

Third, in its request for waiver and interim waiver from the DOE test procedure, RSG stated that the current tolerance requirement of 0.5 °F for the on-coil temperature in section C3.3.3 of AHRI 1250-2009 is unrealistic. *Id.* RSG stated that indoor air temperature tolerances impact the on-coil temperatures, and that the test procedure currently prescribes a 1 °F indoor air temperature test condition tolerance.<sup>8</sup> *Id.* RSG therefore suggested that the on-coil temperature tolerance should also be 1 °F. *Id.* RSG noted further that it can be difficult to repeatedly achieve an on-coil temperature tolerance of 0.5 °F when units are shut down, re-plumbed, and recharged for testing. *Id.*

RSG also requested an interim waiver from the existing DOE test procedure, explaining that if DOE were to deny its application for waiver and interim waiver, it would experience economic hardship in the form of lost sales and/or a significant delay in the distribution into commerce of the specified basic models. *Id.*

On July 22, 2022, DOE published a notification announcing its receipt of the petition for waiver and interim waiver and granted RSG an interim waiver. 87 FR 43808 (“Interim Waiver Order”). In the Interim Waiver Order, DOE initially determined that the alternate test

---

<sup>8</sup> Test condition tolerance is the maximum allowed deviation of the average of the measurements of a parameter made during a test period as compared with its target value. The indoor air dry-bulb test condition tolerance is specified as 1 °F in Table 2 of AHRI 1250-2009.

procedure—with certain minor modifications as discussed in the Interim Waiver Order—appears to allow for the accurate measurement of the energy efficiency of the specified basic models, while alleviating the testing problems cited by RSG in its attempts to implement the DOE test procedure for these basic models. *Id.* at 87 FR 43814. The alternate test procedure established in the Interim Waiver Order is based on the calibrated box method (*i.e.*, Method 2 of AHRI 1250-2009) with modifications to the refrigerant enthalpy test provisions of this method. *Id.* at 87 FR 43813. Using the calibrated box method, the measured capacity includes the thermal loss through the evaporator of the single-packaged dedicated system under test. *Id.* The calibrated box method serves as the primary test method. A modified version of the single-packaged refrigerant enthalpy method is specified in the alternate test procedure for use as a secondary test method.<sup>9</sup> *Id.* Under the modified refrigerant enthalpy method, the refrigerant liquid line length is reduced from 25 feet (as prescribed in AHRI 1250-2009) to a maximum of 5 feet, allows for the capacity measurements of multiple refrigerant circuits, and adds a calculation to estimate the single-packaged thermal loss of the unit under test. *Id.* The capacity as measured by the primary and secondary test methods must be within 6 percent of one another for a valid test. *Id.* at 87 FR 43814.

The alternate test procedure established in the Interim Waiver Order differed from the alternate test procedure proposed by RSG with regard to the condenser air entering wet-bulb temperature test condition. *Id.* RSG proposed that the condenser air entering wet-bulb temperature test condition be 68 °F for single-packaged dedicated systems that do not use evaporative dedicated condensing units, for which all or part of the equipment is located in the

---

<sup>9</sup> A secondary test method's results are used to ensure the capacity tolerance is met when compared to the capacity determined by a primary test method, but are not used for rating performance.

outdoor room. *Id.* Whereas, the alternate test procedure established in the Interim Waiver Order specifies the condensing air entering wet-bulb temperature as 65 °F, which maintains consistency with the requirements in Table 8 of AHRI 1250-2020. *Id.*

In the Interim Waiver Order, DOE solicited comments from interested parties on all aspects of the petition and the specified alternate test procedure. 87 FR 43808, 43809. DOE did not receive any comments in response to the Interim Waiver Order.

On May 4, 2023, DOE published a test procedure final rule (“May 2023 Final Rule”) that established a new test procedure for walk-in coolers and walk-in freezers at appendix C1, in addition to specifying minor amendments to appendix C. 88 FR 28780, 28810. Appendix C1 includes test provisions for multi-circuit single-package dedicated systems that are substantively the same as the methodology granted in the Interim Waiver Order. Use of appendix C1 is not required until the compliance date of any amended energy conservation standards based on the test procedure in appendix C1. Until such time, use of appendix C is required to demonstrate compliance with current standards. As discussed in the May 2023 Final Rule, the amendments to appendix C did not include provisions for multi-circuit single-package dedicated systems.<sup>10</sup> As such, for the basic models subject to the Interim Waiver Order, the need for the waiver from appendix C will continue until such time as use of appendix C1 is required.

For the reasons explained here and in the Interim Waiver Order, absent a waiver the basic models identified by RSG in its petition cannot be tested and rated for energy consumption on a

---

<sup>10</sup> DOE notes a typographical error in Table III.8 of the May 2023 Final Rule. 88 FR 28780, 28827. In that table, the interim waiver granted to RSG was indicated as being addressed by amendments to appendix C, with compliance beginning October 31, 2023. *Id.* The table should have indicated the RSG interim waiver as being addressed by appendix C1, with a compliance date corresponding to “Compliance date of updated standards.”

basis representative of their true energy consumption characteristics. Therefore, DOE has determined that the current test procedure for walk-in cooler refrigeration systems would evaluate the subject basic models in a manner so unrepresentative of its true energy consumption characteristics as to provide materially inaccurate comparative data. DOE has reviewed the recommended procedure suggested by RSG and concludes that, with minor modification to the condenser air entering wet bulb temperature as discussed previously, it will allow for the accurate measurement of the energy use of the equipment, while alleviating the testing problems associated with RSG's implementation of DOE's applicable walk-in test procedure for the specified basic models.

Thus, DOE is requiring that RSG test and rate specified walk-in basic models according to the alternate test procedure specified in this Decision and Order, which is identical to the alternate test procedure specified in the Interim Waiver Order.<sup>11</sup>

This Decision and Order is applicable only to the basic models listed and does not extend to any other basic models. DOE evaluates and grants waivers for only those basic models specifically set out in the petition, not future models that may be manufactured by the petitioner. RSG may request that DOE extend the scope of this waiver to include additional basic models that employ the same technology as those listed in this waiver. 10 CFR 431.401(g). RSG may also submit another petition for waiver from the test procedure for additional basic models that

---

<sup>11</sup> DOE notes that while the test provisions of this Decision and Order are identical to those presented in the Interim Waiver Order, the section numbering of the test provisions specified in this Decision and Order are slightly different than those sections specified in the Interim Waiver Order due to other section numbering changes made to appendix C by the May 2023 Final Rule.

employ a different technology and meet the criteria for test procedure waivers. 10 CFR 431.401(a)(1).

DOE notes that it may modify or rescind the waiver at any time upon DOE's determination that the factual basis underlying the petition for waiver is incorrect, or upon a determination that the results from the alternate test procedure are unrepresentative of the basic models' true energy consumption characteristics. 10 CFR 431.401(k)(1). Likewise, RSG may request that DOE rescind or modify the waiver if the company discovers an error in the information provided to DOE as part of its petition, determines that the waiver is no longer needed, or for other appropriate reasons. 10 CFR 431.401(k)(2).

### III. Order

After careful consideration of all the material that was submitted by RSG, in this matter, it is **ORDERED** that:

(1) RSG must test and rate the following Norlake- and Masterbilt-branded basic models with the test procedure set forth in paragraph (2).

Cooler Basic Models	Freezer Basic Models
CPB050PC-S-0	CPF050PC-S-0
CPB075PC-S-0	CPF075PC-S-0
CPB100PC-S-0	CPF100PC-S-0
	CPF150PC-S-4
	CPF200PC-S-4

(2) The alternate test procedure for the RSG basic models identified in paragraph (1) of this Order is the test procedure for walk-in refrigeration systems prescribed by DOE at 10 CFR part 431, subpart R, appendix C (“appendix C”) as amended by the May 2023 Final Rule, except that multiple-circuit single-packaged dedicated systems shall use: (1) either the calibrated box method or an indoor air enthalpy test as the primary test method, as detailed below; (2) the modified refrigerant enthalpy method as the secondary test method, as detailed below; (3) the net capacity from the primary and secondary test methods must agree within  $\pm 6$  percent, as detailed below; and (4) reported values for the overall system shall be the summation of the gross capacities obtained from the modified refrigerant enthalpy method conducted for each refrigeration circuit included in the unit under test, as detailed below. All other requirements of appendix C as amended by the May 2023 Final Rule and DOE’s regulations remain applicable.

In appendix C:

Revise section 3.1.1 to read as follows:

3.1.1. In Table 1 of AHRI 1250-2009, Instrumentation Accuracy, refrigerant temperature measurements shall have a tolerance of  $\pm 0.5$  °F for unit cooler in/out. Temperature measurements used to determine water vapor content of the air shall be accurate to within  $\pm 0.4$  °F. All other temperature measurements shall be accurate to  $\pm 1.0$  °F.

Revise section 3.1.4 to read as follows:

3.1.4. In Tables 2 through 14 of AHRI 1250-2009, the Test Condition Outdoor Wet Bulb Temperature requirement and its associated tolerance apply only to units with evaporative cooling and single-packaged dedicated systems.

Insert new section 3.1.8 as follows:

3.1.8 Tables 3, 4, 7 and 8 of AHRI 1250-2009 shall be modified to read as follows:

**Table 3 – Fixed Capacity Matched Refrigerator System, Condensing Unit Located Indoor**

Test Description	Unit Cooler Air Entering Dry-Bulb, °F	Unit Cooler Air Entering Relative Humidity, (%)	Condenser Air Entering Dry-Bulb, (°F)	Condenser Air Entering Wet-Bulb, °F	Compressor Capacity	Test Objective
Off Cycle Fan Power	35	<50	-	-	Compressor Off	Measure fan input wattage during compressor off cycle
Refrigeration Capacity	35	<50	90	75 <sup>1</sup> or 65 <sup>2</sup>	Compressor On	Determine Net Refrigeration Capacity of Unit Cooler, input power, and EER at Rating Condition

<sup>1</sup> Required only for evaporative Dedicated Condensing Units

<sup>2</sup> Maximum allowable value for Single-Packaged Dedicated Systems that do not use evaporative Dedicated Condensing Units, where all or part of the equipment is located in the outdoor room.

**Table 4 – Fixed Capacity Matched Refrigerator System, Condensing Unit Located Outdoor**

Test Description	Unit Cooler Air Entering Dry-Bulb, °F	Unit Cooler Air Entering Relative Humidity, (%)	Condenser Air Entering Dry-Bulb, (°F)	Condenser Air Entering Wet-Bulb, °F	Compressor Capacity	Test Objective
Off Cycle Fan Power	35	<50	-	-	Compressor Off	Measure fan input wattage during compressor off cycle
Refrigeration Capacity A	35	<50	95	75 <sup>1</sup> or 68 <sup>2</sup>	Compressor On	Determine Net Refrigeration Capacity of Unit Cooler, input power, and EER at Rating Condition
Refrigeration Capacity B	35	<50	59	54 <sup>1</sup> or 46 <sup>2</sup>	Compressor On	Determine Net Refrigeration Capacity of Unit Cooler, and system input power at moderate condition.

Refrigeration Capacity C	35	<50	35	34 <sup>1</sup> or 29 <sup>2</sup>	Compressor On	Determine Net Refrigeration Capacity of Unit Cooler, and system input power at cold condition.
--------------------------	----	-----	----	------------------------------------	---------------	--

<sup>1</sup> Required only for evaporative Dedicated Condensing Units.

<sup>2</sup> Maximum allowable value for Single-Packaged Dedicated Systems that do not use evaporative Dedicated Condensing Units, where all or part of the equipment is located in the outdoor room.

**Table 7 – Fixed Capacity Matched Freezer System, Condensing Unit Located Indoor**

Test Description	Unit Cooler Air Entering Dry-Bulb, °F	Unit Cooler Air Entering Relative Humidity, (%)	Condenser Air Entering Dry-Bulb, (°F)	Condenser Air Entering Wet-Bulb, °F	Compressor Capacity	Test Objective
Off Cycle Fan Power	-10	<50	-	-	Compressor Off	Measure fan input wattage during compressor off cycle
Refrigeration Capacity	-10	<50	90	75 <sup>1</sup> or 65 <sup>2</sup>	Compressor On	Determine Net Refrigeration Capacity of Unit Cooler, input power, and EER at Rating Condition
Defrost Frost Load	-10	Various	90	75 <sup>1</sup> or 65 <sup>2</sup>	System Dependent	Test according to section C11 of AHRI 1250-2009.

<sup>1</sup> Required only for evaporative Dedicated Condensing Units.

<sup>2</sup> Maximum allowable value for Single-Packaged Dedicated Systems that do not use evaporative Dedicated Condensing Units, where all or part of the equipment is located in the outdoor room.

**Table 8 – Fixed Capacity Matched Freezer System, Condensing Unit Located Outdoor**

Test Description	Unit Cooler Air Entering Dry-Bulb, °F	Unit Cooler Air Entering Relative Humidity, (%)	Condenser Air Entering Dry-Bulb, (°F)	Condenser Air Entering Wet-Bulb, °F	Compressor Capacity	Test Objective
Off Cycle Fan Power	-10	<50	-	-	Compressor Off	Measure fan input wattage during compressor off cycle
Refrigeration Capacity A	-10	<50	95	75 <sup>1</sup> or 68 <sup>2</sup>	Compressor On	Determine Net Refrigeration Capacity of Unit Cooler, input power, and EER at Rating Condition
Refrigeration Capacity B	-10	<50	59	54 <sup>1</sup> or 46 <sup>2</sup>	Compressor On	Determine Net Refrigeration Capacity of Unit Cooler, input power, and EER at Rating Condition
Refrigeration Capacity C	-10	<50	35	34 <sup>1</sup> or 29 <sup>2</sup>	Compressor On	Determine Net Refrigeration Capacity of Unit Cooler, input

						power, and EER at Rating Condition
Defrost Frost Load	-10	Various	95	75 <sup>1</sup> or 68 <sup>2</sup>	System Dependent	Test according to section C11 of AHRI 1250-2009.
<sup>1</sup> Required only for evaporative Dedicated Condensing Units. <sup>2</sup> Maximum allowable value for Single-Packaged Dedicated Systems that do not use evaporative Dedicated Condensing Units, where all or part of the equipment is located in the outdoor room.						

Remove section 3.2.5.

Add a new section 4, following section 3.5 *Hot Gas Defrost Refrigeration Systems*

#### 4.0 Multiple-Circuit Single-Packaged Dedicated Systems

When conducting testing in accordance with AHRI 1250-2009 (incorporated by reference; see 10 CFR 431.303), the following modifications must be made.

##### 4.1 *Specific modifications: Test Conditions and Tolerance*

4.1.1 Replace section C3.1.2 of AHRI 1250-2009 with the following: Air wet-bulb and dry-bulb temperatures entering the Single-Packaged Dedicated System at its evaporator return and condenser air inlet shall be measured based on the airflow area at the point of measurement. One measuring station is required for each 2.0 ft<sup>2</sup> of the first 10.0 ft<sup>2</sup> of airflow area and one additional measuring station is required for each 4.0 ft<sup>2</sup> of airflow area above 10.0 ft<sup>2</sup>. A minimum of two stations shall be used and the number of measuring stations shall be rounded up to the next whole number.

4.1.2 Replace section C3.1.5 of AHRI 1250-2009 with the following: If sampling tubes are used, each tube opening may be considered a temperature measuring station provided the openings are uniformly spaced along the tube, the airflow rates entering each port are relatively

uniform ( $\pm 15\%$ ) and the arrangement of tubes complies with the location requirements of section C3.1.2 of AHRI 1250-2009. Additionally, a one-time temperature traverse shall be made over the measurement surface, prior to the tests to assess the temperature variation and ensure it complies with the allowable deviation specified in section C3.1.4 of AHRI 1250-2009. (Refer to ANSI/ASHRAE Standard 41.1 for more information and diagrams). If sampling tubes are not used for single-packaged dedicated systems that do not use evaporative dedicated condensing units, a single air wet-bulb or RH sensor may be used. When used, this sensor shall be located at the geometric center of the largest condenser coil face and 6-12 inches from the condenser coil.

4.1.3 Replace section 3.1.6 of AHRI 1250-2009 with the following: Refrigerant temperatures entering and leaving the evaporator section of the Single-Packaged Dedicated System shall be measured by a temperature measuring instrument placed in a thermometer well and inserted into the refrigerant stream. These wells shall be filled with non-solidifying, thermal conducting liquid or paste to ensure the temperature sensing instrument is exposed to a representative temperature. The entering temperature of the refrigerant shall be measured within six pipe diameters upstream of the expansion device. If the refrigerant tube outer diameter is less than  $\frac{1}{2}$ -inch, the refrigerant temperature may be measured using the average of two temperature measuring instruments with a minimum accuracy of  $\pm 0.5$  °F placed on opposite sides of the refrigerant tube surface. In this case, the refrigerant tube shall be insulated with 1-inch-thick insulation from a point 6 inches upstream of the measurement location to a point 6 inches downstream of the measurement location. Also, the entering measurement location may be moved to a location 6 inches upstream of the expansion device.

#### 4.2 *Refrigerant Properties Measurement*

4.2.1 Replace section C3.3.1 of AHRI 1250-2009 with the following: With the equipment operating at the desired test conditions, the temperature and pressure of the refrigerant leaving the unit cooler, entering the expansion device, and entering and leaving the compressor shall be measured. For cases where the calibrated box method or indoor air enthalpy method is also conducted, data used to calculate capacity according to the single-package refrigerant enthalpy method and the additional method shall be collected over the same intervals.

4.2.2 Replace section C3.3.3 of AHRI 1250-2009 with the following: For Single-Packaged Dedicated Systems tested using either the calibrated box method or the indoor air enthalpy method as the primary measurement and the single-package refrigerant enthalpy method as the secondary method, a preliminary test for Rating Condition A using the primary method is required prior to setting up the refrigerant enthalpy method measurements. In preparation for this preliminary test, temperature sensors shall be attached to the equipment's evaporator and condenser coils. The sensors shall be located at points that are not affected by vapor superheat or liquid subcooling. Placement near the midpoint of the coil, at a return bend, is recommended. The preliminary test shall be conducted with the requirement that the temperatures of the on-coil sensors be included with the regularly recorded data. After the preliminary test is completed, the refrigerant shall be removed from the equipment, and the refrigerant enthalpy measurement setup shall be completed. The equipment shall be evacuated and recharged with refrigerant. The test shall then be repeated. Once steady-state operation is achieved, refrigerant shall be added or removed until, as compared to the average values from the preliminary test, the following conditions are achieved: (1) each on-coil temperature sensor indicates a reading that is within  $\pm 1.0$  °F, (2) the temperatures of the refrigerant entering and leaving the compressor are within  $\pm 4$  °F, and (3) the refrigerant temperature entering the

expansion device is within  $\pm 1$  °F. Once these conditions have been achieved over an interval of at least ten minutes, refrigerant charging equipment shall be removed, and the remaining tests shall be conducted.

4.2.3 When conducting the refrigerant enthalpy method for a Single-Packaged Dedicated System, the length of the added liquid line conducting refrigerant out of the system, to the flow meter, and back into the system shall be no more than 5 feet. No such modification to the suction line shall be made.

#### 4.3 *Methods for Testing for Walk-in Cooler and Freezer Systems that Have Matched Unit Coolers and Condensing Units.*

Disregard section C5 of AHRI 1250-2009 and instead test according to the following method:

4.3.1 The Refrigeration Capacity for Single-Packaged Dedicated Systems shall be determined using either the Calibrated Box method or the Indoor Air Enthalpy method as a primary test method and the Single-Package Refrigerant Enthalpy method as the secondary test method.

4.3.1.1 Single-Package Refrigerant Enthalpy method shall determine gross refrigeration capacity by measuring the enthalpy change and the mass flow rate of the refrigerant using a single set of measurements.

4.3.1.2 Calibrated Box method shall determine net refrigeration capacity by measuring the heat input to the calibrated box, including thermal transfer through the calibrated box walls.

4.3.2 Indoor Air Enthalpy method shall determine net refrigeration capacity of Single-Packaged Dedicated System and input power in accordance with ASHRAE 37-2009, Figure C4 of AHRI 1250-2020, and the following modifications.

4.3.2.1 Net refrigeration capacity is determined by measuring airflow rate and the dry-bulb temperature and water vapor content of the air that enters and leaves the coil.

4.3.2.2 Air enthalpies shall be determined in accordance with ANSI/ASHRAE 41.6. Entering air is to be sufficiently dry as to not produce frost on the evaporator coil. Therefore, only sensible capacity measured by dry bulb change shall be used to calculate capacity.

4.3.3 Testing Sequence. The primary test method shall be used to measure the capacity for Rating Condition A prior to set-up of the Single-Package Refrigerant Enthalpy Measurement. After set-up of the Refrigerant Enthalpy method, the Net Capacity shall be measured using both the primary test method and the Refrigerant Enthalpy method. The Net Capacity measurement using the Refrigerant Enthalpy method shall be within 6 percent of the net capacity measurement using the primary method.

If a capacity balance within tolerance is not initially achieved, take steps to reduce the thermal losses of the Single-Packaged Dedicated System evaporator compartment by sealing air gaps and potentially adding more external insulation. If using the Calibrated Box method as the primary method, achieving a capacity balance may require conducting the calibration with calibrated box insulation material at the same average temperature as during capacity measurement, or using

multiple calibrations conducted at different average insulation material temperatures and using these data to construct a correlation for the calibration coefficient,  $K_{cb}$ , as a function of average insulation temperature. The official performance measurements are based on the primary method testing without any air gap sealing and additional external insulation used to achieve the 6 percent energy balance in place.

4.3.4 The refrigerant enthalpy method Net Capacity shall be calculated from the Gross Capacity Measurement as follows.

$$\dot{q}_{ss,2} = Q_{ref} - 3.412 \times E \dot{F}_{comp,on} - Q_{sploss}$$

Where  $Q_{sploss}$  represents the Single-Packaged Dedicated System thermal losses through the walls of the evaporator side of the Single-Packaged Dedicated System to the condenser side and to the exterior ambient, and shall be calculated as follows.

$$Q_{sploss} = UA_{cond} \times (T_{condside} - T_{evapside}) + UA_{amb} \times (T_{amb} - T_{evapside})$$

Where:

$UA_{cond}$  and  $UA_{amb}$  are, for the condenser/evaporator partition and the evaporator compartment walls exposed to ambient air, respectively, the product of the overall heat transfer coefficient and surface area of the unit as manufactured, *i.e.*, without external insulation that might have been added during the test;

$T_{evapside}$  is the air temperature in the evaporator compartment;

$T_{condside}$  is the air temperature in the condenser compartment; and

$T_{amb}$  is the air temperature outside the Single-Packaged Dedicated System.

The Net Capacity to be used in AWEF calculations shall be the net capacity measured using the primary method.

4.3.5 Upon the completion of the Rating Condition A steady state test, an off-cycle evaporator fan power test shall be conducted to measure the evaporator fan power consumption during a compressor-off period in accordance with section C10 of AHRI 1250-2009.

4.3.6 Upon the completion of the Rating Condition A steady state test for walk-in freezer systems, a mandatory defrost test shall be conducted to establish the energy input for a defrost cycle.

4.3.7 Upon the completion of the Rating Condition A steady state test, off-cycle evaporator fan power test, and defrost test (for walk-in freezer systems), the Rating Condition B and C steady state tests shall be conducted. Capacity balance as described in section C9.2 of AHRI 1250-2020 for Rating Condition A is not required for Rating Conditions B and C.

#### *4.4 Test Chamber Requirements*

Disregard section C6 of AHRI 1250-2009 and instead test according to the following method:

4.4.1 For single-packaged dedicated systems, test chamber requirements shall be as follows:

- a. For the calibrated box method, follow ASHRAE 16-2016 Section 6.1 for calibrated type calorimeters excluding water and water energy inputs for the indoor-side compartment.
- b. For the indoor air enthalpy method, follow ASHRAE 37-2009.

#### *4.5 Single-Packaged Dedicated System Refrigerant Enthalpy Method*

4.5.1 General Description. In this method, capacity is determined from the refrigerant enthalpy change and flow rate. Enthalpy changes are determined from measurements of entering and leaving pressures and temperatures of the refrigerant, and the flow rate is determined by a suitable flow meter in the liquid line. This method shall not be used for tests in which the refrigerant liquid leaving the flow meter is subcooled less than 3°F or for tests in which any instantaneous measurement of the superheat of the vapor leaving the evaporator coil is less than 5°F. Supplementary cooling may be artificially provided for the liquid line to ensure enough subcooling when making measurements to establish the capacity balance for Rating Condition A, however, no official measurements used to calculate AWEF may be made while providing such supplementary cooling.

4.5.2 Measurements. Refer to Section 4.1 of this appendix and section C3 of AHRI 1250-2009 for requirements of air-side and refrigerant-side measurements.

4.5.3 Test Setup and Procedure. Refer to Section 4.4 of this appendix, section C7 of AHRI 1250-2009, and Figure C3 of this section for specific test setup. The length of the added liquid line shall be 5 feet, maximum.

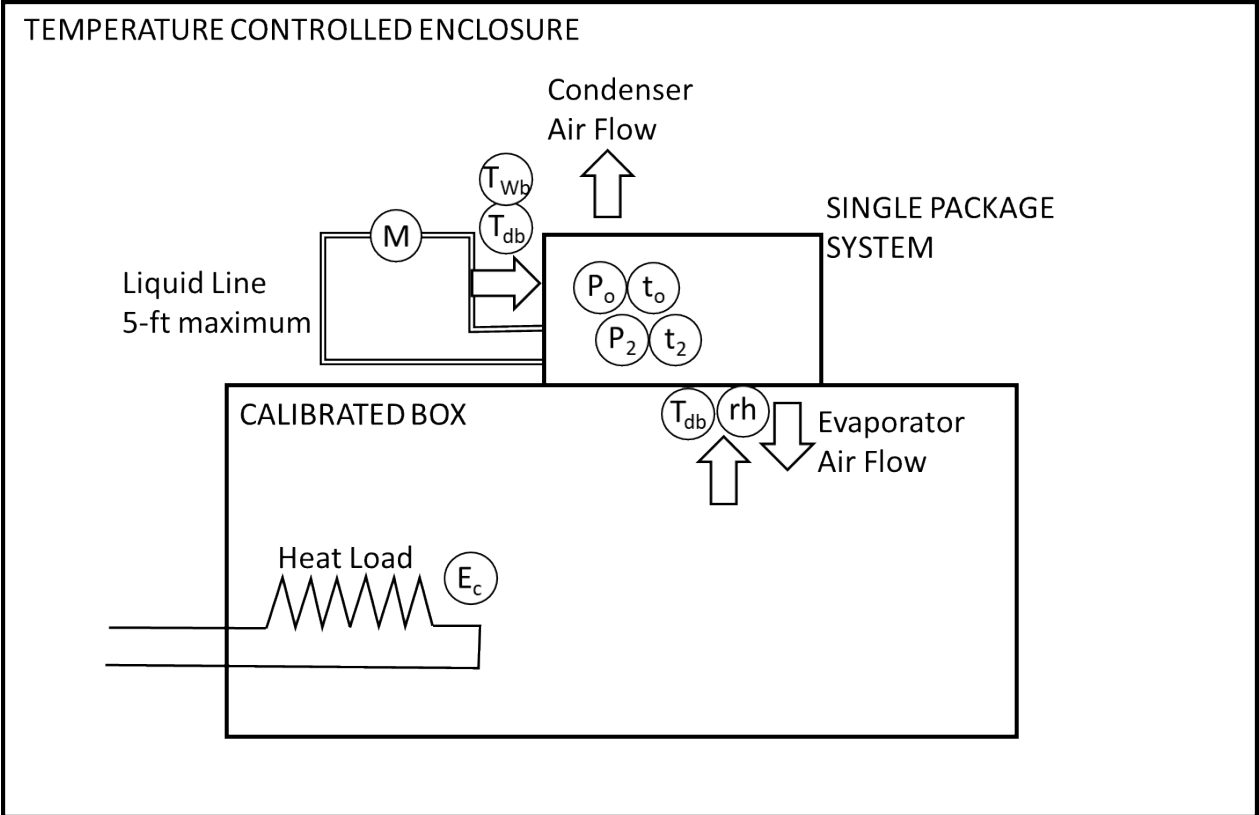

LEGEND	
(M)	Mass Flow Meter
(T <sub>db</sub> ) (T <sub>wb</sub> )	Air Temperature Measurement Station
(rh)	Air Relative Humidity Measurement
(P)	Refrigerant Pressure Measurement
(t)	Refrigerant Temperature Measurement Station
(E <sub>c</sub> )	Heat Load Input Power

**Figure C3: Calibrated Box and Single-package Refrigerant Enthalpy Method**

4.5.4 Data to be Measured and Recorded. Refer to “Refrigerant Enthalpy Method” in Table C2 in section C7.2 of AHRI 1250-2009 for the required data that need to measured and recorded, except as follows.

4.5.4.1 Water vapor content of air entering the unit cooler (evaporator) and condensing unit may be measured using a wet bulb temperature measurement or a relative humidity sensor, but both are not required.

4.5.4.2 Wet bulb temperature of air leaving the unit cooler (evaporator) and condensing unit need not be measured.

4.5.4.3 Required refrigerant pressure measurement includes only subcooled liquid entering the expansion valve and superheated vapor exiting the unit cooler (evaporator).

4.5.4.4 Only one refrigerant mass flow measurement is required.

4.5.4.5 Measurement of Refrigerant oil flow rate and oil/refrigerant mass ratio are not required.

#### 4.5.5 Refrigeration Capacity Calculation.

4.5.5.1 The refrigerant-side gross capacity is calculated by

$$Q_{ref} = \dot{m}_{ref}(h_{out} - h_{in})$$

4.5.5.2 Measurement of Capacity for a Single-Packaged Dedicated System with Multiple Refrigeration Circuits.

For a Single-Packaged Dedicated System with multiple refrigeration circuits, apply the refrigerant enthalpy method separately for each circuit and sum the separately-measured gross refrigeration capacities.

#### 4.6 *Calibrated Box Test Procedure*

4.6.1 Measurements. Refer to section 4.1 of this section and section C3 of AHRI 1250-2009 for requirements of air-side and refrigerant-side measurements.

4.6.2 Apparatus setup for Calibrated Box Calibration and Test. Refer to section 4.4 of this section, section C7 of AHRI 1250-2009, and Figure C4 of this section for specific test setup.

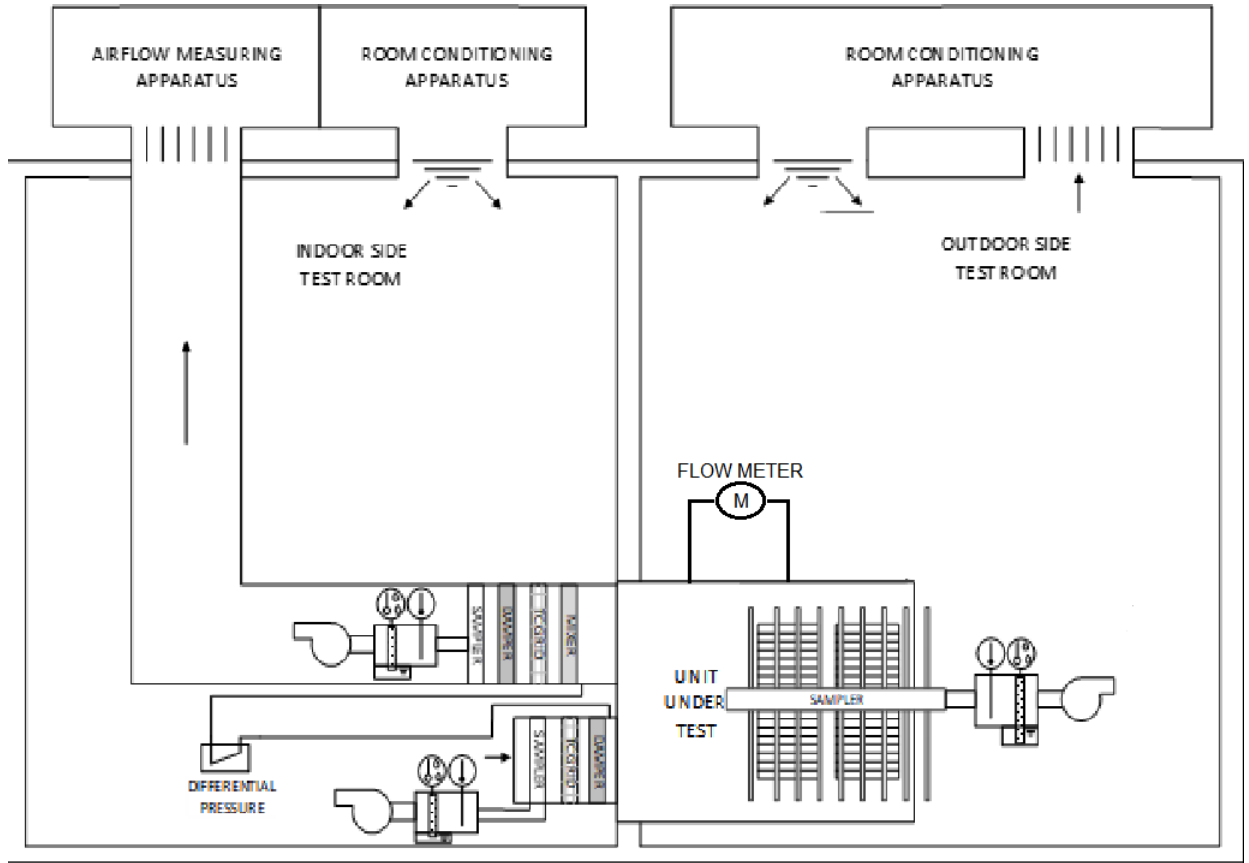

**Figure C4: Indoor Air Enthalpy and Single-package Refrigerant Enthalpy Method**

4.6.2.1 The calibrated box shall be installed in a temperature-controlled enclosure in which the temperature can be maintained at a constant level. When using the calibrated box method for Single-Packaged Dedicated Systems, the enclosure air

temperature shall be maintained such that the condenser air entering conditions are as specified for the test.

4.6.2.2 The temperature-controlled enclosure shall be of a size that will provide clearances of not less than 18 in at all sides, top and bottom, except that clearance of any one surface may be reduced to not less than 5.5 inches.

4.6.2.3 The heat leakage of the calibrated box shall be noted in the test report.

4.6.2.4 Refrigerant lines within the calibrated box shall be well insulated to avoid appreciable heat loss or gain.

4.6.2.5 Instruments for measuring the temperature around the outside of the calibrated box to represent the enclosure temperature  $T_{en}$  shall be located at the center of each wall, ceiling, and floor.

*Exception:* in the case where a clearance around the outside of the calibrated box, as indicated above, is reduced to less than 18 inches, the number of temperature-measuring devices on the outside of that surface shall be increased to six, which shall be treated as a single temperature to be averaged with the temperature of each of the other five surfaces. There will be six rectangular sections of equal area, and each of these six sections will have a temperature-measuring instrument located at its center. If the refrigeration system is mounted at the location that would cover the center of the face on which it is mounted, up to four temperature measurements shall be used on that face to represent its temperature. Each sensor shall be aligned with the center of the face's nearest outer edge and centered on the distance between that edge and the single-packaged unit (this is illustrated in Figure C5 when using surface temperature sensors), and they shall be

treated as a single temperature to be averaged with the temperature of each of the other five surfaces. However, any of these sensors shall be omitted if either (a) the distance between the outer edge and the single-packaged unit is less than one foot or (b) if the sensor location would be within two feet of any of the foot-square surfaces discussed below representing a warm discharge air impingement area. In this case, the remaining sensors shall be used to represent the average temperature for the surface.

One of the following two approaches shall be used for the box external temperature measurement. Box calibration and system capacity measurement shall both be done using the same one of these approaches.

4.6.2.5.1 Air temperature sensors. Each temperature sensor shall be at a distance of 6 inches from the calibrated box. If the clearance from a surface of the box (allowed for one surface only) is less than 12 inches, the temperature measuring instruments shall be located midway between the outer wall of the calibrated box and the adjacent surface.

4.6.2.5.2 Surface temperature sensors. Surface temperature sensors shall be mounted on the calibrated box surfaces to represent the enclosure temperature,  $T_{en}$ .

Additional surface temperature sensors may be used to measure external hot spots during refrigeration system testing. If this is done, two temperature sensors shall be used to measure the average temperature of the calibrated box surface covered by the condensing section—they shall be centered on equal-area rectangles

comprising the covered calibrated box surface whose common sides span the short dimension of this surface. Additional surface temperature sensors may be used to measure box surfaces on which warm condenser discharge air impinges. A pattern of square surfaces measuring one foot square shall be mapped out to represent the hot spot upon which the warm condenser air impinges. One temperature sensor shall be used to measure surface temperature at the center of each square (see Figure C5 of this section). A drawing showing this pattern and identifying the surface temperature sensors shall be provided in the test report. The average surface temperature of the overall calibrated box outer surface during testing shall be calculated as follows.

$$T_{en} = \frac{\sum_{i=1}^6 A_i T_i + \sum_{j=1}^2 A_j (T'_j - T_1) + \sum_{k=1} A_k (T''_k - T_1)}{\sum_{i=1}^6 A_i}$$

Where:

$A_i$  is the surface area of the  $i^{\text{th}}$  of the six calibrated box surfaces;

$T_i$  is the average temperature measured for the  $i^{\text{th}}$  surface;

$A_j$  is half of the surface area of the calibrated box covered by the condensing section;

$T'_j$  is the  $j^{\text{th}}$  of the two temperature measurements underneath the condensing section;

$T_1$  is the average temperature of the four or fewer measurements representing the temperature of the face on which the single-packaged system is mounted, prior to adjustments associated with hot spots based on measurements  $T_j$  and/or  $T_k$ ;

$A_k$  is the area of the  $k^{\text{th}}$  of  $n$  1-square-foot surfaces used to measure the condenser discharge impingement area hot spot; and,

$T''_k$  is the  $k^{\text{th}}$  of the  $n$  temperature measurements of the condenser discharge impingement area hot spot.

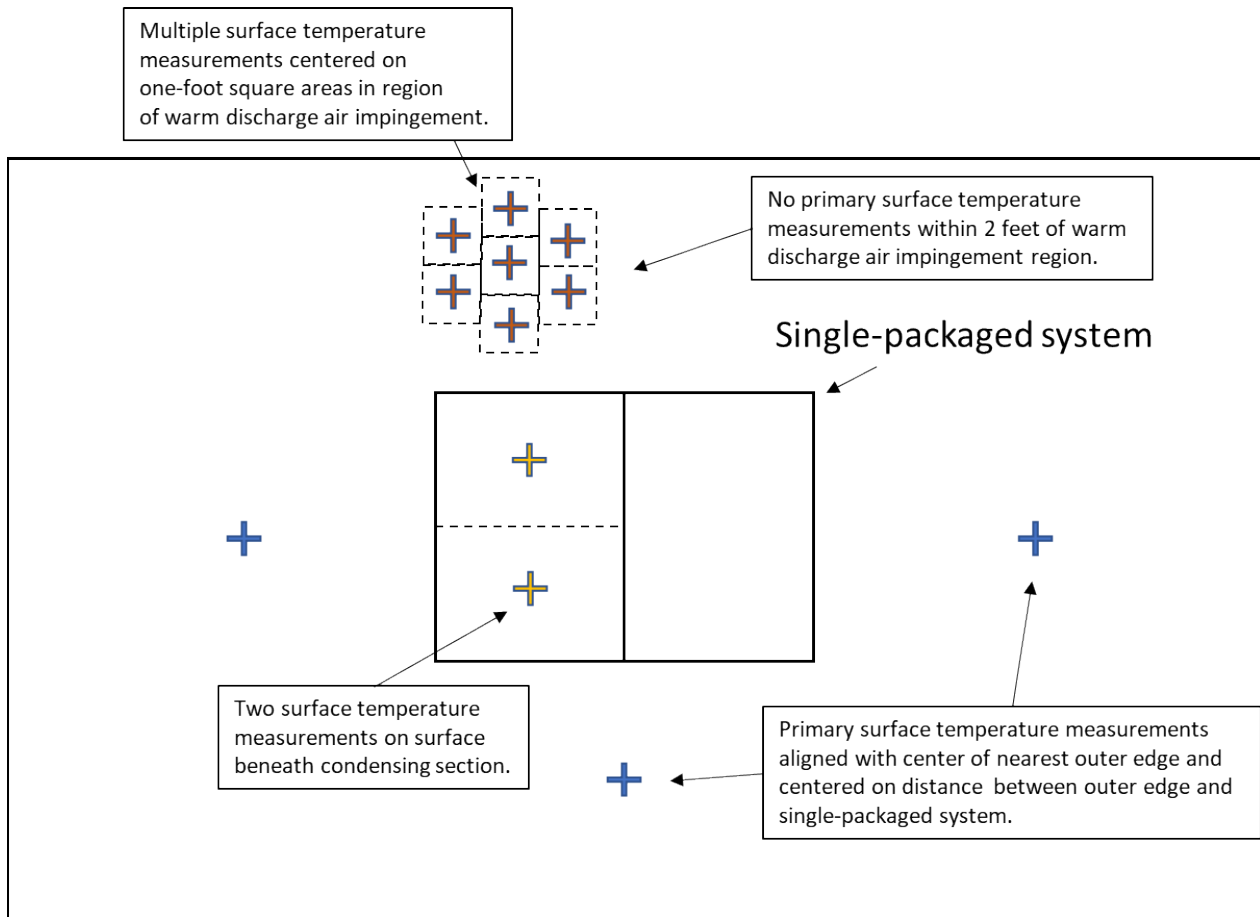

**Figure C5: Illustration of Layout of Surface Temperature Sensors on Face of Calibrated Box on which Single-Packaged System is Mounted when Using Section 4.6.2.5.2 of 10 CFR Part 431 Subpart R, Appendix C.**

4.6.2.6 Heating means inside the calibrated box shall be shielded or installed in a manner to avoid radiation to the Single-Packaged Dedicated System, the temperature measuring instruments, and to the walls of the box. The heating means shall be

constructed to avoid stratification of temperature, and suitable means shall be provided for distributing the temperature uniformly.

4.6.2.7 The average air dry-bulb temperature in the calibrated box during Single-Packaged Dedicated System tests and calibrated box heat leakage tests shall be the average of eight temperatures measured at the corners of the box at a distance of 2 inches to 4 inches from the walls. The instruments shall be shielded from any cold or warm surfaces except that they shall not be shielded from the adjacent walls of the box. The Single-Packaged Dedicated System under test shall be mounted such that the temperature instruments are not in the direct air stream from the discharge of the Single-Packaged Dedicated System.

4.6.3 Calibration of the Calibrated Box. Calibration of the Calibrated Box shall occur prior to installation of the Single-Packaged Dedicated System. This shall be done either (a) prior to cutting the opening needed to install the Single-Packaged Dedicated System, or (b) with an insulating panel with the same thickness and thermal resistance as the box wall installed in the opening intended for the Single-Packaged Dedicated System installation. Care shall be taken to avoid thermal shorts in the location of the opening either during calibration or during subsequent installation of the Single-Packaged Dedicated System. A calibration test shall be made for air movements comparable to those expected for Single-Packaged Dedicated System capacity measurement, *i.e.*, with air volume flow rate within 10 percent of the air volume flow rate of the Single-Packaged Dedicated System evaporator.

4.6.3.1 The heat input shall be adjusted to maintain an average box temperature not less than 25.0 °F above the test enclosure temperature.

4.6.3.2 The average dry-bulb temperature inside the calibrated box shall not vary more than 1.0 °F over the course of the calibration test.

4.6.3.3 A calibration test shall be the average of eleven consecutive hourly readings when the box has reached a steady-state temperature condition.

4.6.3.4 The box temperature shall be the average of all readings after a steady-state temperature condition has been reached.

4.6.3.5 The calibrated box has reached a steady-state temperature condition when:

4.6.3.5.1 The average box temperature is not less than 25 °F above the test enclosure temperature.

4.6.3.5.2 Temperature variations do not exceed 5.0 °F between temperature-measuring stations.

4.6.3.5.3 Temperatures do not vary by more than 2 °F at any one temperature-measuring station.

4.6.4 Data to be Measured and Recorded. Refer to Table C2 in section C7.2 of AHRI 1250-2020 for the required data that need to be measured and recorded.

4.6.5 Refrigeration Capacity Calculation.

4.6.5.1 The heat leakage coefficient of the calibrated box is calculated by

$$K_{cb} = \frac{3.412 \times E_c}{T_{en} - T_{cb}}$$

4.6.5.2 For each Dry Rating Condition, calculate the Net Capacity:

$$\dot{q}_{ss} = K_{cb}(T_{en} - T_{cb}) + 3.412 \times E_c$$

(3) *Representations.* RSG may not make representations about the efficiency of a basic model listed in paragraph (1) of this Order for compliance, marketing, or other purposes unless that basic model has been tested in accordance with the provisions set forth in this alternate test procedure and such representations fairly disclose the results of such testing.

(4) This Order shall remain in effect until the date upon which use of appendix C1 is required to demonstrate compliance with any amended energy conservation standards based on the test procedure in appendix C1.

(5) This Order is issued on the condition that the statements and representations provided by RSG are valid. If RSG makes any modifications to the controls or configurations of any basic model subject to this Order, such modifications will render the waiver invalid with respect to that basic model, and RSG will either be required to use the current Federal test method or submit a new application for a test procedure waiver. DOE may rescind or modify this waiver at any time if it determines the factual basis underlying the petition for the waiver is incorrect, upon a determination that the results from the alternate test procedure are unrepresentative of a basic model's true energy consumption characteristics, or for other appropriate reasons. 10 CFR 431.401(k)(1). Likewise, RSG may request that DOE rescind or modify the waiver if RSG discovers an error in the information provided to DOE as part of its petition, determines that the waiver is no longer needed, or for other appropriate reasons. 10 CFR 431.401(k)(2).

(6) Issuance of this Order does not release RSG from the applicable requirements set forth at 10 CFR part 429.

DOE makes decisions on waivers and interim waivers for only those basic models specifically set out in the petition, not future models that may be manufactured by the petitioner. RSG may submit a new or amended petition for waiver and request for grant of interim waiver, as appropriate, for additional basic models of single-packaged dedicated systems with multiple refrigeration circuits. Alternatively, if appropriate, RSG may request that DOE extend the scope of a waiver or an interim waiver to include additional basic models employing the same technology as the basic models set forth in the original petition consistent with 10 CFR 431.401(g).

### **Signing Authority**

This document of the Department of Energy was signed on November 17, 2023, by Jeffrey Marootian, Principal Deputy Assistant Secretary for Energy Efficiency and Renewable, pursuant to delegated authority from the Secretary of Energy. That document with the original signature and date is maintained by DOE. For administrative purposes only, and in compliance with requirements of the Office of the Federal Register, the undersigned DOE Federal Register Liaison Officer has been authorized to sign and submit the document in electronic format for publication, as an official document of the Department of Energy. This administrative process in no way alters the legal effect of this document upon publication in the *Federal Register*.

Signed in Washington, DC, on November 17, 2023

Jeffrey M. Marootian  
xMarootian

Digitally signed by  
Jeffrey M. Marootian  
Date: 2023.11.17  
11:59:09 -05'00'

---

Jeffrey Marootian,  
Principal Deputy Assistant Secretary  
for Energy Efficiency and Renewable Energy  
U.S. Department of Energy