

***21st CENTURY TRUCK***  
**PARTNERSHIP<sup>SM</sup>**

# **Electrification Technologies Sector Team Roadmap**



***21st CENTURY TRUCK***  
**PARTNERSHIP<sup>SM</sup>**

# **Electrification Technologies Sector Team Roadmap**

# Table of Contents

<b>Message from the Leadership</b> .....	<b>vi</b>
<b>Executive Summary: Proposed Goals and Opportunities for Advanced Electrified Powertrain Research and Development</b> .....	<b>1</b>
<b>Introduction and Background</b> .....	<b>4</b>
The 21CTP Electrification Technologies Sector Team .....	4
Truck-Specific Electrification Research and Development.....	9
Medium- and Heavy-Duty vs. Light-Duty Vehicles .....	9
Environmental and Cost Imperatives .....	10
Roadmap Scope.....	12
<b>Technology Status: MHDV Electric Propulsion</b> .....	<b>13</b>
Detailed Vehicle Description .....	13
Segmentation and Charging Scenarios.....	13
Powertrain Architectures .....	14
Key Assumptions .....	15
Vehicle Requirements .....	17
Total Cost of Ownership (TCO) vs. Levelized Cost of Driving (LCOD) .....	17
<b>Technical Targets</b> .....	<b>19</b>
Levelized Cost of Driving .....	19
Factors Outside 21CTP Control.....	19
LCOD Technology Analysis .....	19
Electrical Energy Storage.....	24
Charging/Infrastructure .....	25
Electrification Components.....	29
<b>Technical Gaps and Barriers</b> .....	<b>31</b>
Powertrain Systems Architecture .....	31
Vehicle Performance Requirements and a Reference Drive Cycle.....	31
Model Validation .....	31
Consistent Use of Assumption Data across All 21CTP Technical Teams and Working Groups .....	32
Electrical Energy Storage.....	32
Cost, Status.....	32

Performance.....	32
Life.....	33
Abuse Tolerance.....	33
Recycling and Sustainability .....	33
Modular Design .....	33
Charging/Infrastructure .....	34
Electrification Components.....	34
Electric Motors .....	34
Power Devices .....	35
Power Modules .....	35
DC Link Capacitors.....	35
Motor Insulation.....	36
Magnets.....	36
Conductor/Wiring .....	36
<b>Strategy to Achieve Technical Targets: Approaches for Overcoming Barriers/Challenges .....</b>	<b>37</b>
Powertrain System Architecture .....	37
High-Power-Computing-Based Modeling.....	37
Vehicle Control Optimization .....	37
Electrical Energy Storage.....	37
High-Power-Computing-Based Collection of Data, Modeling .....	37
Battery Packaging, System Architecture, and Integration .....	38
Applied Battery Materials Research and Development .....	38
Electrical Infrastructure.....	39
Electrification Components.....	39
Comparison to USDRIVE.....	40
<b>Appendix – LCOD Analysis.....</b>	<b>44</b>
<b>Bibliography.....</b>	<b>41</b>
<b>Acronyms and Nomenclature.....</b>	<b>44</b>

## List of Figures

Figure ES-1. Recommended segments and operational conditions for commercial vehicle target setting.....	3
Figure 1. 21st Century Truck Partnership Technical (“Tech”) Teams .....	4
Figure 2: A high-level schematic of powertrains under consideration.....	5
Figure 3: 21CTP areas of interest.....	6
Figure 4. 21CTP ETST WG interactions.....	7
Figure 5: Categories of interest, ETST objectives, and working groups.....	8
Figure 6: Primary energy consumption shares in 2015 (Mai et al. 2018).....	10
Figure 7: Weekly diesel retail prices in the United States (U.S. Energy Information Administration 2021) .....	11
Figure 8: Average 10-year per-mile cost of driving diesel trucks in 2025 (Gohlke et al. 2021).....	11
Figure 9: Recommended segments and operational conditions for commercial vehicle target setting.....	14
Figure 10: Top 20 commercial vehicle body types in rank order by estimates for fuel use, miles, and population .....	14
Figure 11. Conventional vs. BEV drive train for 2020–2040 for Class 8 long haul.....	20
Figure 12. Conventional vs. BEV drive train for 2020–2040 for Class 8 regional haul.....	21
Figure 13. Conventional vs. BEV drive train for 2020–2040 for Class 6 box truck.....	22
Figure 14. Conventional vs. BEV drive train for 2020–2040 for Class 4 step van .....	23
Figure 15. LCOD values for Class 8 long haul tractor .....	44
Figure 16. LCOD values for Class 8 regional haul tractor .....	45
Figure 17. LCOD values for Class 6 box truck.....	45
Figure 18. LCOD values for Class 4 step van .....	46

## List of Tables

Table 1: 21CTP ETST Objectives .....	5
Table 2. Key Vehicle Characteristics of Interest.....	16
Table 3. High-Level Requirements for Several Vocations .....	17
Table 4. Analysis of the Differences Between TCO and LCOD .....	17
Table 5. Battery, Motor, and Inverter Costs .....	18
Table 6. Preliminary Battery Requirements.....	24
Table 7. Depot Charging Parameter Assumptions.....	27
Table 8. Rest Area (Travel Center) Charging Parameter Assumptions .....	27
Table 9. En Route Charging Parameter Assumptions .....	28
Table 10. Cost of Electricity Results from Various Scenarios.....	28
Table 11. Weighted Cost of Electricity by Vocation Used in the PSA WG LCOD Analysis.....	28
Table 12. Technical Requirements for Traction Drive.....	29
Table 13. Technical Requirements for Inverter .....	29
Table 14. Technical Requirements for Motor .....	30

## Message from the Leadership

The 21st Century Truck Partnership (21CTP) would like to acknowledge the valuable inputs from all of our partners in creating this technical roadmap. We greatly appreciate the technical expertise of the subject matter experts at the U.S. Department of Energy's national laboratories in helping create the technical roadmap sections. We also appreciate the technical input from the many industry and government partners who provided input through participation in group discussions about the roadmap. The information provided in this roadmap represents the current views of the contributing members of the **Electrification Technologies Sector Team**, following review and comment by members of the Executive Management Team, Senior Executive Steering Committee, and other senior management involved in oversight of 21CTP operations, as of the release date below.

NOTE: Achievement of the goals contained in this document is subject to a number of factors, including the availability of funding to perform the advanced research work. The Partnership will review and potentially revise this document annually to ensure that it accurately reflects current and emerging goals, funding availability, and any relevant emerging technical or market information. Major new releases are planned at three- to five-year intervals.



John Kresse  
Industry Co-Chair and Director, Advanced Electrification  
Cummins Inc.

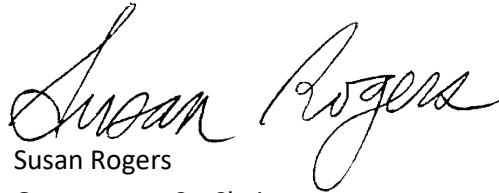

Susan Rogers  
Government Co-Chair  
U.S. Department of Energy, Vehicle Technologies Office

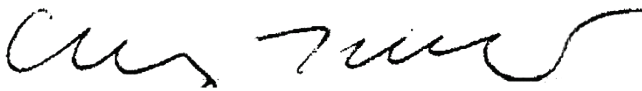

Andrej Ivanco  
Industry Deputy Co-Chair and Senior Engineer, Research  
and Development  
Allison Inc.



Michael Laughlin  
Federal Manager, 21st Century Truck Partnership  
U.S. Department of Energy, Vehicle Technologies Office

September 2023

# Executive Summary: Proposed Goals and Opportunities for Advanced Electrified Powertrain Research and Development

The medium- and heavy-duty vehicle (MHDV) industry is at the start of an important transition. Regulators, society and, in many cases, end users are challenging the industry to move to a low carbon future. Electrified powertrains (battery electric, fuel cell, and/or low carbon fueled hybrids) will play a dominant role in this transition; however, for certain important commercial applications, there are shortcomings in existing electrified solutions.

The 21st Century Truck Partnership Electrification Technologies Sector Team (ETST) aims to **identify technical targets for components and systems that will enable operators and vehicle original equipment manufacturers (OEMs) to cost-effectively meet the challenges of vehicle electrification for a wide variety of end-user duty cycles**. While MHDV electrification is already occurring for a limited application set, the identified targets can form the basis for U.S. Department of Energy-sponsored research that will allow for a dramatic deployment of electrified powertrains.

MHDVs have unique operational characteristics that may differ substantially from those of light-duty vehicles (LDVs) (e.g., MHDVs have more extreme duty cycles). In addition, MHDVs have much higher power requirements for charging than LDVs because of the battery size and charge time requirement. Lastly, the MHDV market differs from the LDV market in that MHDV fleets are run as businesses and make their purchasing decisions based on hard data, such as total cost of ownership. These attributes translate into requirements that challenge direct adoption of already developed (or soon-to-be-developed) LDV electrification technology. To achieve the full potential of electrification, MHDVs require development of a specific set of dedicated technologies.

To this end, the ETST developed this roadmap to identify research and development (R&D) strategies specific to MHDVs that can facilitate their widescale transition to electrification. This roadmap has been organized into four technology focus areas, each supported by one of four national laboratory-moderated working groups within the ETST.

- ▶ Powertrain System and Architecture
  - Led by Vincent Freyermuth, Argonne National Laboratory, Ram Vijayagopal, Argonne National Laboratory and Jason Lustbader, National Renewable Energy Laboratory
- ▶ Battery/Energy Storage
  - Led by Lee Walker, Idaho National Laboratory, and Simon Thompson, U.S. Department of Energy
- ▶ Electrification Components
  - Led by Burak Ozpineci, Oak Ridge National Laboratory
- ▶ Infrastructure
  - Led by Andrew Meintz, National Renewable Energy Laboratory

The technical team and supporting working groups have focused on identifying targets that can enable fleet customers to meet mission requirements at cost parity to advanced diesel. The most challenging top-level tasks identified are 1) developing effective battery technology to support Class 8 linehaul and 2) developing an electric charging infrastructure to cost-effectively support widespread use of commercial battery electric MHDVs. Other technologies, such as development of lower-cost, higher-power dense electric motors, will also help increase adoption of electrified

powertrains.

These strategies will inform 21CTP's R&D portfolio. Top-priority R&D needs are summarized below.

- ▶ **Performance and reference drive cycle data for the top recommended MHDV vocations:** Levelized cost of driving (LCOD) is now one of the primary tools for comparing different technologies. In fact, the most successful commercial fleets already use their own version of this tool as they are making their annual fleet purchases of MHDVs. Correctly modeling/calculating the LCOD for any given vocation requires a drive cycle to accurately represent a typical day in the life of that commercial vehicle. Good data are currently available for Class 8 tractors, including both long haul and regional distribution. Unfortunately, this is not the case for most of the MHDV's. Significant resources must be focused on obtaining representative performance and drive cycle data for each of the top 10 vocations identified in Figure ES-1.
- ▶ **Computer model validation:** The U.S. Department of Energy has been funding high fidelity vehicle system simulation research to quantify the impact of advanced technologies on energy, performance and cost for several decades focusing primarily on light duty vehicles. The focus on medium- and heavy-duty applications is fairly recent and additional validation is required against both dynamometer testing and real-world operations.
- ▶ **Architecture Analysis by Vocation:** Once the reference drive cycles are developed and validated for the top 10 vocations – we can then use these models to begin an analysis on the various driveline architectures possible. The MHDV market is very diverse in both drive cycles and performance requirements. As each vocation is optimized for performance and efficiency, this diversity will lead to multiple driveline configurations and architectures – based upon the specific vocation being analyzed. Understanding the possibility of using common components across multiple applications will be critical to achieve the volumes necessary to bring down the cost.
- ▶ **High-power charging station infrastructure:** Successfully electrifying the MHDV fleet will require a national strategy to meet the overall increased electricity demand and deploy the infrastructure required to charge MHDVs at depots, travel centers, and en route charging facilities (i.e., rest areas). Some of these charging stations could exceed 1 MW per vehicle.
- ▶ **Reduced cost for batteries and electrical components:** For electrified MHDVs to achieve cost parity with conventional MHDVs, the cost of both the batteries and electrified components must be reduced. Continued research into new technologies that will help to reduce these costs is imperative.
- ▶ **Battery performance:** MHDVs will place much higher demand upon battery performance than LDVs. Energy and power requirements for MHDVs can easily be 4–5 times those of LDVs. There is a need for continued research into new technologies that will help to improve battery performance.
- ▶ **Reliability, life, and abuse requirements:** To maintain productivity and revenue levels, a business's MHDVs must have long lifecycles—much longer than those of LDVs. In fact, a million miles is not unusual for many of the MHDV vocations. Therefore, all the components that go into an electrified powertrain must be capable of both high reliability and long life. Because of the difficult drive cycles of many of the MHDV vocations, all the electrified components must also be capable of withstanding harsh environmental abuse. There is a need for continued research into new technologies that will help to improve reliability, life, and abuse tolerance.

- ▶ **Centralized storage area for all modeling assumption data:** Vast research capabilities exist within both DOE and the national laboratory system. Unfortunately, the same breadth of research capabilities can lead to variable assumptions that can be built into modeling architectures. Establishing a centralized storage area for all modeling assumption data would strengthen 21CTP modeling capabilities and support more consistent and predictable results. The storage area should be freely accessible to 21CTP members for their review and contributions.
- ▶ **HEV Configuration for Class 8 Long Haul:** BEV Class 8 Long Haul tractors may not be competitive with diesel powered tractors regarding LCOD for some time. In an effort to support a stable transition for HD vehicle electrification (including electrified accessories), and at the same time reducing carbon emissions, Hybrid Electric Vehicle (HEV) configurations should be pursued in the future.

Group	Vocation	Body Style	Timeframe (Production / Model Year)
A. Significant Fuel Use Reduction	1. Long-Haul 2. Local Delivery	1. CL 8 Sleeper 2. CL 8 Day Cab	<ul style="list-style-type: none"> <li>• 2020 - baseline</li> <li>• 2025</li> <li>• 2030</li> </ul>
B. Early Adopters & Important Vocations to consider for Alternative Fuels	3. Pick-up & Delivery 4. Pick-up & Delivery 5. Transit (City) 6. Service Vehicles (Significant Engine Off PTO Usage) 7. General Purpose 8. Heavy Vocational 9. Heavy Vocational 10. School Bus	3. CL 6 Box Truck 4. CL 4 Step Van 5. CL 8 Bus 6. CL 4 or 5 Service 7. CL 3 Pickup 8. CL 8 Dump 9. CL 8 Refuse 10. CL 6/7 School Bus	<ul style="list-style-type: none"> <li>• 2035</li> <li>• Beyond 2035 - long term</li> </ul>

Figure ES-1. Recommended segments and operational conditions for commercial vehicle target setting

## Introduction and Background

### The 21CTP Electrification Technologies Sector Team

The U.S. Department of Energy (DOE) 21<sup>st</sup> Century Truck Partnership (21CTP) initiative aims to foster technological innovation that improves the energy efficiency and reduces the costs of the nation’s economically vital truck freight transportation system. 21CTP has four technology focus areas, shown in Figure 1. For each technology area, 21CTP has established a Technical Team, or “Tech Team”:

- ▶ Internal Combustion Engine Technologies Sector Team
- ▶ Electrification Technologies Sector Team
- ▶ Freight Operational Efficiency Technologies Sector Team
- ▶ Safety Technologies Sector Team

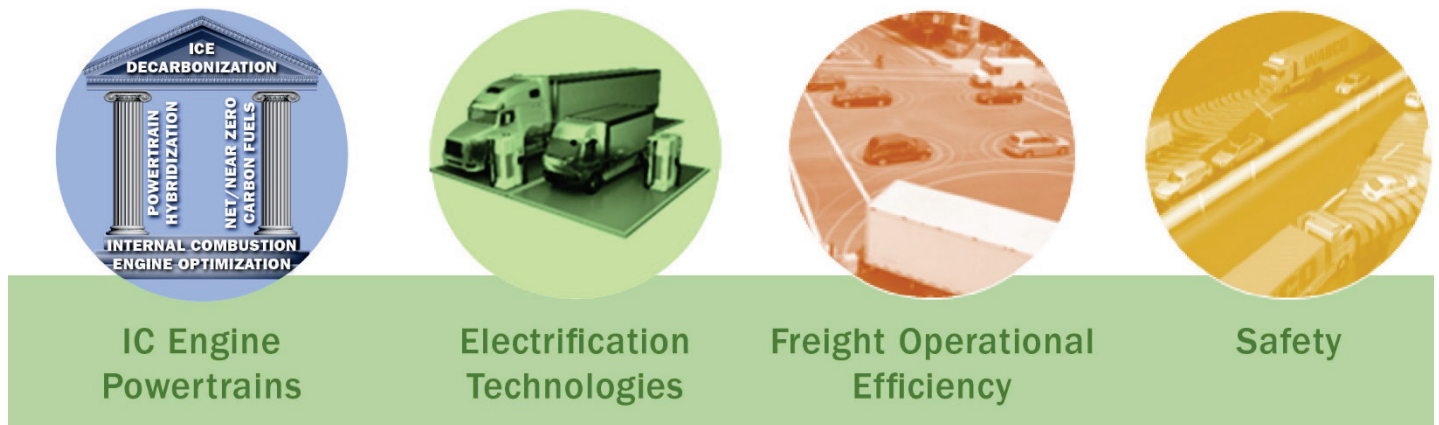

**Figure 1. 21st Century Truck Partnership Technologies (“Tech”) Sector Teams**

The Electrification Technologies Sector Team (ETST) investigates technologies and techniques that can facilitate the introduction of plug-in hybrid vehicles (PHEVs) and battery electric vehicles (BEVs) to the medium- and heavy-duty vehicle (MHDV) market.

To achieve our nation’s energy security, economic competitiveness, and environmental stewardship goals, new technologies must be implemented for vehicle propulsion, moving beyond advanced internal combustion engines (ICEs) and fossil fuels, transmissions, and drivelines. New propulsion technologies include various degrees of electrification, from mild-hybrid vehicles to full BEVs. The ETST is focused on evaluating the performance and cost impacts from the various propulsion technologies based on the levelized cost of driving (LCOD) for the vehicle. (Note that fuel cell electric vehicles are also an area of interest but do not fall under the current Electrification Technologies Sector Team scope. In

addition, net-zero carbon fuels are also an area of interest but fall under the 21CTP Internal Combustion Engine Technologies Sector Team scope) Figure 2 depicts the powertrains under consideration (discussed in more detail in the section on Powertrain Architectures).

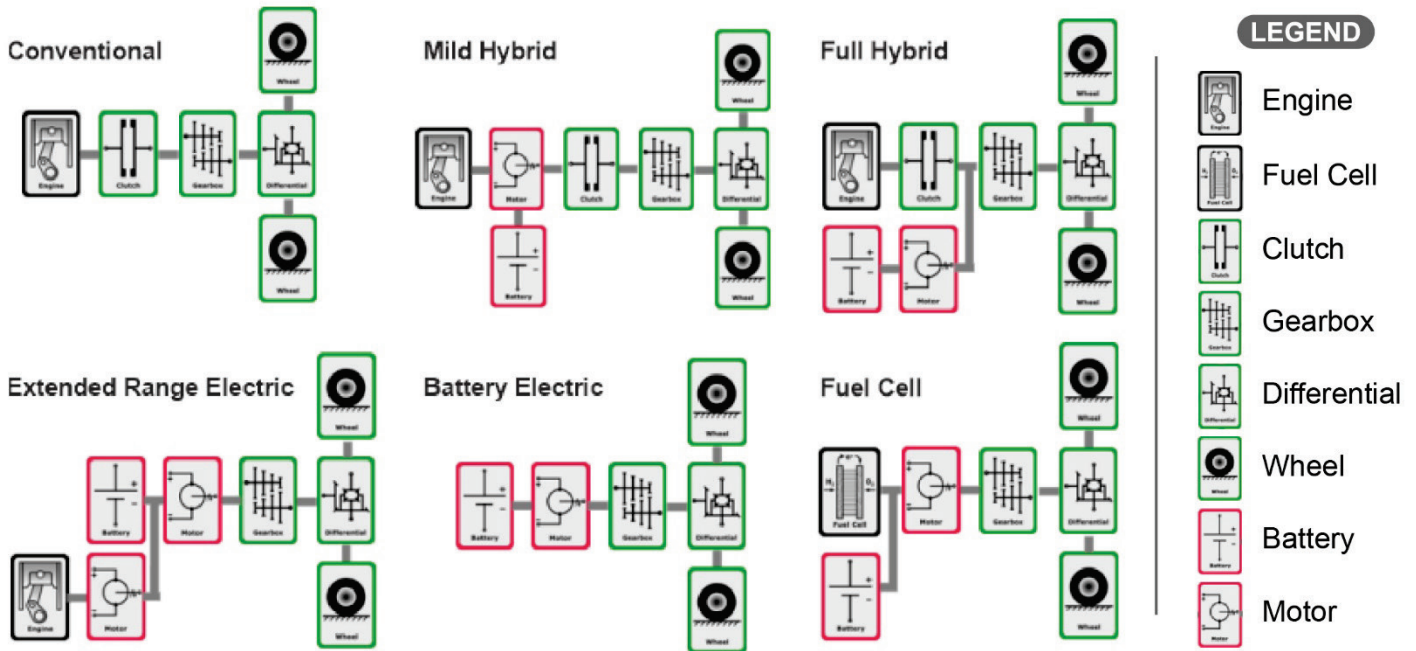

Figure 2. A high-level schematic of powertrains under consideration

The ETST has identified four primary objectives that will help attain the 21CTP vision for electrification. The main ETST objective is to achieve cost parity while meeting performance and durability requirements with a conventional ICE from the LCOD perspective as quickly as possible. The other three objectives are supportive of the first: identification of component technologies that facilitate cost parity, technology validation, and information-sharing. These goals focus on Class 3 MHDVs that are above 10,000 pounds (5 tons).

Table 1 below provides the ETST goals with additional detail.

Table 1: 21CTP ETST Objectives

21 CTP ETST Objectives	Description
<b>Cost parity analysis and Specific, Measurable, Achievable, Relevant, and Time-Bound goal setting</b>	Develop performance and cost criteria for electrified propulsion, and related electrified components, to reach parity with ICE-powered Class 3 to 8 MHDVs.
<b>Technology identification and analysis</b>	Identify and analyze electrified component technology that may be applicable to achieving the criteria outlined in Objective 1.
<b>Technology validation</b>	Develop common system and sub-system validation techniques to avoid duplicate efforts and accelerate the speed of deployment.

**Information aggregation and sharing**

Document and synthesize existing experience from the light-duty vehicle (LDV) industry, prior DOE-sponsored activities, academia, and other publicly available resources and standards committees.

The ETST has also identified nine areas of interest, as depicted in Figure 3. Each of these areas of interest is directly relevant to one of the research objectives above.

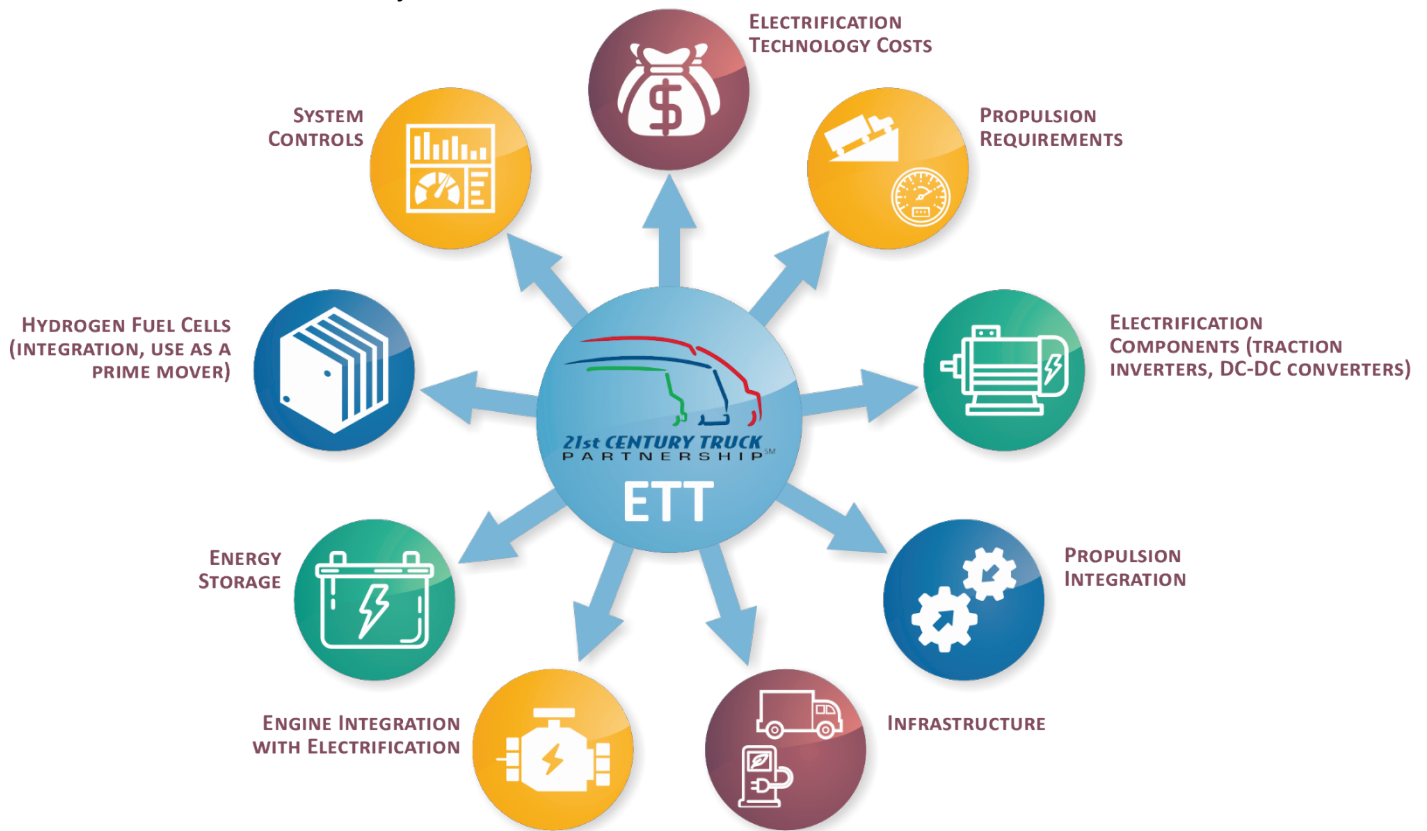

Figure 3. 21CTP areas of interest

The ETST has divided its efforts into four major categories, or working groups (WGs), each specializing in a different technology, to pursue these categories of interest and attain these objectives.

- **Powertrain Systems Architecture (PSA) and LCOD – Responsible for vehicle requirements consolidation and system modeling to evaluate cost vs. benefits implications**
- **Battery/Energy Storage – Focusing on battery technology and quantifying its impact on the overall vehicle operation and LCOD**
- **Electrification Components – Essential components to electrify vehicle propulsion while minimizing the LCOD (much of this technology can also be used with FCEVs)**
- **Infrastructure – Mapping of high-power charging requirements while ensuring proper grid integration**

The four working groups, which cover eight of the nine categories of interest, are developing technical targets. (As noted above, hydrogen fuel cells and associated targets are being pursued by another group.) Information flows between these groups in an organized and systematic approach (see Figure 4). This information is then used in ETST models to project future LCOD calculations as compared to the current baseline. This approach will be used to set and refine the 21CPT technology targets for the ETST.

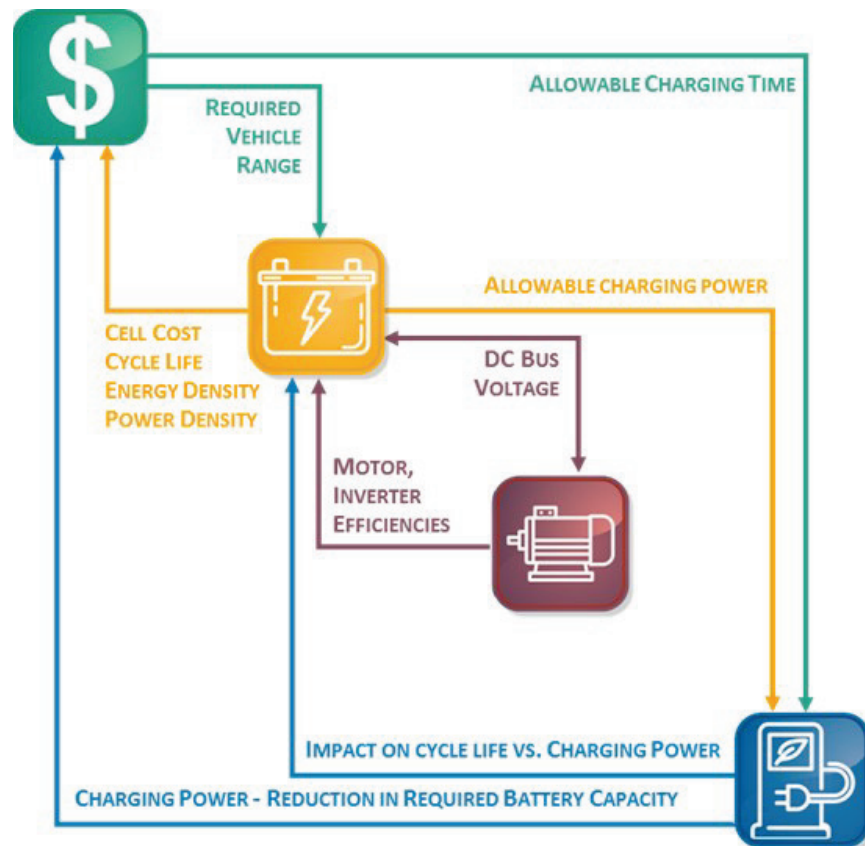

Figure 4. 21CPT ETST WG interactions

The pairing of objectives, categories of interest, and working groups is shown below in Figure 5. Note that not all categories of interest are within the scope of this roadmap, as discussed later in this section.

- 
**1: Electrification Technology Costs**
  - ▶ Analyzing the TCO and cost sensitivity
    - Powertrain System Architecture WG
- 
**2: Powertrain Requirements**
  - ▶ Defining the application requirements to meet user expectations in propulsion performance
    - Powertrain System Architecture WG
- 
**3: Electrification Components**
  - ▶ Defining technology of interest for electric motors, inverters, and DC-DC converters
    - Power Electronics WG
- 
**4: Powertrain Integration**
  - ▶ Identifying the necessary requirements and interoperability for vehicle integration
    - Not addressed in this roadmap
- 
**5: Infrastructure**
  - ▶ Charging and refueling
    - Electrification Infrastructure WG
- 
**6: Engine Integration with Electrification**
  - ▶ Integrating ICE, as the primary energy source, with electrification to develop mild and full hybrids
    - Powertrain System Architecture WG
- 
**7: Energy Storage**
  - ▶ Focusing on electrochemical storage (batteries)
    - Battery WG
- 
**8: Hydrogen Fuel Cell**
  - ▶ Replacing or working with the battery as the primary energy source
  - ▶ Examining fuel cell integration and use cases
  - ▶ Collaborating closely with the DOE Fuel Cell Technologies Office
    - Not addressed in this roadmap
- 
**9: System Controls**
  - ▶ Achieving superior efficiency through smart control and connectivity
    - Not addressed in this roadmap

Figure 5. Categories of interest, ETST objectives, and working groups

Additional guidance in these technical areas is available in the Run on Less website (NACFE n.d.), which provides electric truck training, and in Medium- and Heavy-Duty Vehicle Electrification: An Assessment of Technology and Knowledge Gaps (Oak Ridge National Laboratory and National Renewable Energy Laboratory 2019).

## Truck-Specific Electrification Research and Development

### Medium- and Heavy-Duty vs. Light-Duty Vehicles

To some extent, the goals and technologies developed in the LDV market can be leveraged within the MHDV market. For example, cost and performance improvements in batteries may transfer from the LDV segment to the MHDV segment, and some electrical components will also share new technology between LDVs and MHDVs. However, the MHDV market space is very diverse—much more so than the LDV market. The MHDV market sector is significantly more complex regarding durability, power and torque requirements, life expectancy, variety of applications, etc. Therefore, it is likely that a variety of technology solutions will be required to meet the full spectrum of needs within the MHDV market.

Beyond the specifics internal to engine design, characteristics of the MHDV market segment are different from the LDV market segment:

- ▶ **Charging.** Most LDVs charge overnight at home, and when LDVs must be charged elsewhere, a low-power charger works in a workplace or other long-dwell location, but high-power charging is used in short-dwell en route scenarios. However, the operation of many MHDV applications may require high-power chargers to minimize the charging time (“dwell time”) and to account for the larger MHDV batteries.
  - Presumably, some fleets/vocations that can charge using a “depot” charging strategy will be able to adopt new electrification technologies more quickly and easily than vocations that will require a high-power-charging national grid.
- ▶ **Power take-off and/or Auxiliary Load operation.** For an LDV, most of the energy requirement is driven by the need for propulsion, with some energy needed for heating and cooling. However, MHDVs have variable power needs. A few examples; 1) a refuse truck can require a significant increase in overall energy to run the hydraulic systems, 2) a utility (service) truck worker may drive a short distance to a work site, turn off the engine, and run the bucket up and down all day and 3) a city bus can almost double the energy required when running the Heating, Venting and Air Conditioning (HVAC) system in extreme temperatures. Therefore, it will be very important to identify good “reference drive cycles” that can capture additional energy requirements for each vocation.
- ▶ **Purchase criteria.** The MHDV market also differs from the LDV market in that MHDV fleets are run as businesses and make their purchasing decisions based on hard data, such as LCOD. Before new technologies can mature and gain widespread acceptance in the MHDV market, the LCOD will have to be reduced and viability in a highly cost-sensitive environment will have to be proven.
- ▶ **Durability.** The life of a MHDV is 4–5 times that of most LDV’s. It is not uncommon to demand 1,000,000 miles of durability from a MHDV.

## Environmental and Cost Imperatives

The freight and commercial trucks (MHDV) category is essential for goods and passenger movement and accounts for approximately 25% of the energy consumption within the transportation sector. Compared to the industrial, commercial, and residential sectors, the transportation sector is the most dependent on “non-electricity-based” energy (see Figure 6) Almost 100% of “freight trucks” depend on liquefied, combustion-based fuels—mostly diesel. In response, fuel consumption and greenhouse gas emissions standards for MDHVs are becoming more stringent.<sup>1</sup>

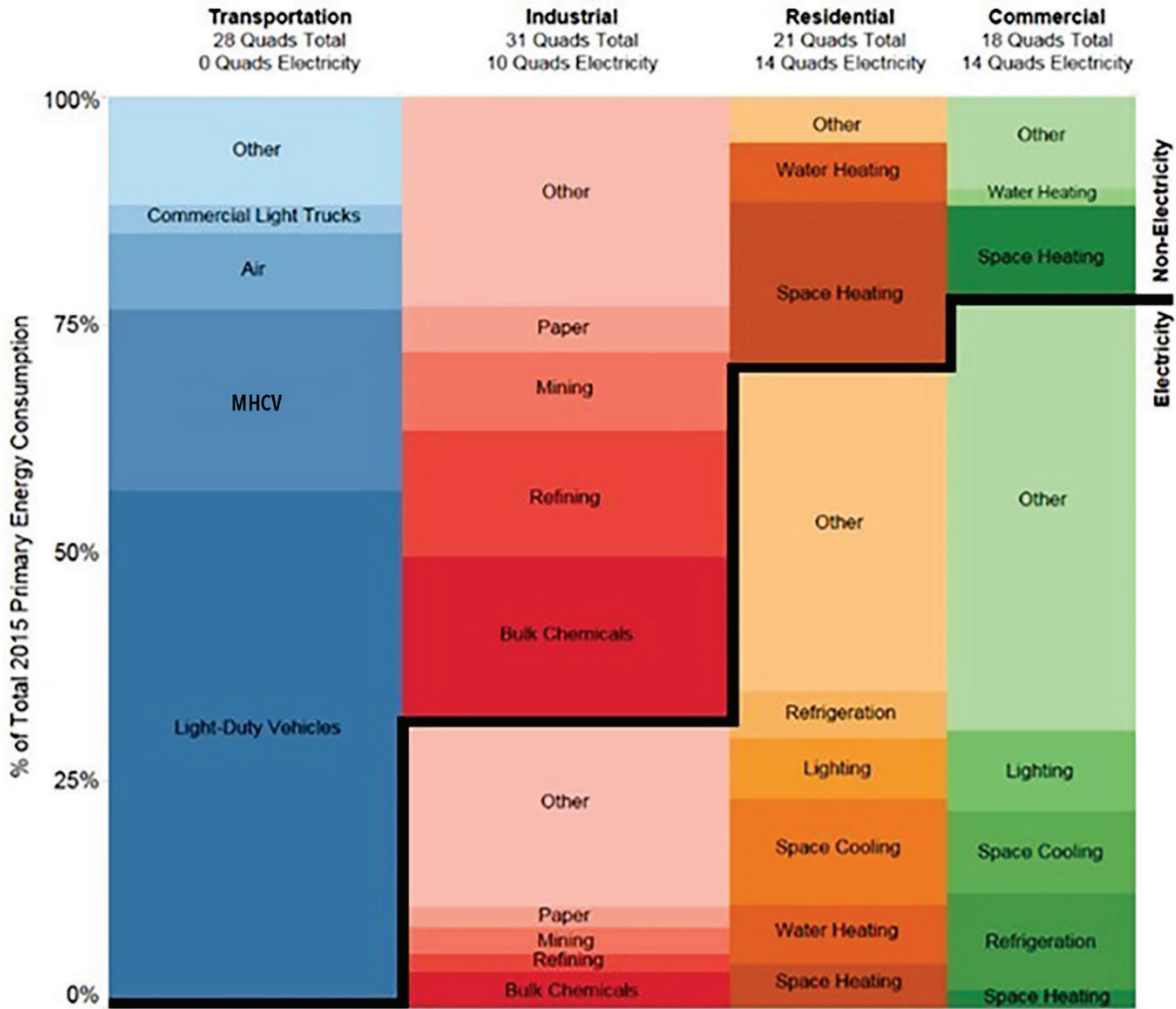

Figure 6. Primary energy consumption shares in 2015 (Mai et al. 2018)

<sup>1</sup> For example, the California Air Resources Board (CARB) has proposed a heavy-duty omnibus regulation, which would establish engine emission standards for nitrogen oxides (NOx) that are 90% lower than current standards (CARB 2021), and the Advanced Clean Trucks regulation, which requires manufacturers to sell zero-emission trucks as an increasing percentage of their annual California sales (CARB n.d.)



**Figure 7. Weekly diesel retail prices in the United States (U.S. Energy Information Administration 2021)**

In addition to the environmental impact, fuel is the second-highest monetary cost for most truck fleets (Torrey and Murray 2016, GNA 2020). As shown in Figure 7, the cost of fuel for the MHDV fleets has been highly variable over the past 20 years. Large swings in the fuel cost will likely continue (alongside changes in political and global economic pressures). As a result, MHDV fleets are subject to unpredictable energy costs—costs that are passed along to consumers.

To combat these challenges, a focus should be placed on fuel diversification. Electricity, compressed natural gas, propane, net-carbon- neutral fuels, and hydrogen energy sources should all be considered for future use, given a fair and thorough analysis on a complete LCOD basis (National Energy Technology Laboratory 2021). Keeping the fuel cost stabilized, or even lowered, will help ensure stable and predictable energy costs for transportation. (Note that driver labor is the single highest cost for most fleets [Figure 8].) When autonomous driving becomes safe and reliable, it will be the single largest contributor to reducing a fleet’s LCOD, which would likely result in a paradigm shift in the trucking industry since driving time will no longer contribute to the LCOD.

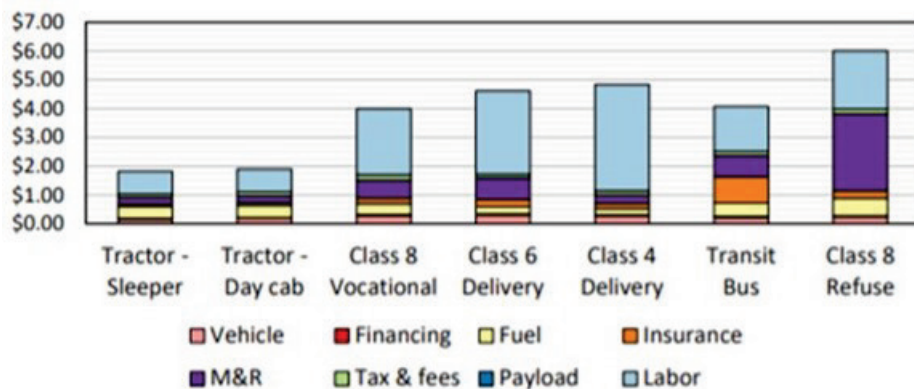

**Figure 8. Average 10-year per-mile cost of driving diesel trucks in 2025 (Gohlke et al. 2021)**

## Roadmap Scope

This roadmap focuses on finding ways to reduce energy consumption through MHDV electrification, which will be beneficial from an environmental, economic, and national energy security perspective. There is a need for new technology that will be cost-effective in the MHDV market sector. 21CTP can support the development of advanced technologies such as battery electric, hybrid electric, and fuel cell traction drives that will meet new regulations while staying cost-competitive with the current solutions. This roadmap can guide the R&D support that will lead to commercially viable propulsion technologies.

This roadmap aims to identify and clarify the characteristics that are specific to MHDVs, as well as to capture the various technical requirements for electrification technologies such that commercial vehicle customers will have cost-effective solutions for each vocation/application, which can range from a school bus to a long haul delivery truck (see the section on Detailed Vehicle Description, especially Fig 9 and Fig 10). This document considers how best to move new technologies and techniques forward. It describes the current technology status, outlines recommended goals and targets, identifies major barriers to achieving those targets, and suggests approaches to overcoming these barriers.

The energy source for an electrified vehicle can be a battery, hydrogen, or a combination of both. To manage its scope, this roadmap focuses on the battery as the primary energy source. A separate “H2 and Fuel Cell Roadmap” is being prepared by a different team with specific knowledge and backgrounds in this technology area. Having said that, many of the technologies developed within this roadmap can also be utilized when a fuel cell is the primary source of energy. Therefore, cross-communication between these two groups is highly encouraged.

Similarly, there are three additional 21CTP Tech Teams, and both the Freight Operational Efficiency and the Safety Tech Sector Teams have crossover technical areas into electrification that can be referenced within their respective roadmaps. As noted above, the four ETST working groups are developing technical targets. In this roadmap, these targets have been established in ten-year increments, with 2020 considered the baseline year.

Note that this roadmap does not address cradle-to-grave or cradle-to-cradle assessments of the technologies. Evaluating the full lifecycle environmental impact (Life Cycle Assessment LCA) of an electrified MHDV requires accounting for the source of energy for charging, whether the source be a fossil-fuel-based power plant, renewable energy, etc.—in other words, well to wheels rather than tank to wheels. Recent studies regarding the amount of energy needed for electrifying miles driven by commercial vehicles (estimated as 169TWh for most of the MHDV BEV fleet—minus Class 8 Long Haul [NACFE 2022]), the dividing line between energy and transportation sectors becomes blurry—for an order of magnitude comparison, US electricity production in 2020 was 4,000 TWh. Having said that, the bigger issues for charging MHDV's revolve around where (Depots, Rest Areas, and En Route Truck Stops) and when (electricity typically costs more during peak usage hours) the electricity is available. Moreover, technology areas such as vehicle-to-grid can alleviate intermittency of renewable sources and accelerate their integration into the national grid. Another aspect of lifecycle analysis is end-of-life disposal. These topics do need to be addressed, especially given the projected market volume of electrified MHDVs, but they are outside of the scope of this ETST roadmap.

## Technology Status: MHDV Electric Propulsion

Several manufacturers have demonstrated their ability to reduce fuel consumption and emissions through electrification. During the 2021 DOE Vehicle Technologies Office (VTO) Annual Merit Review, several presentations addressed these demonstration projects (DOE VTO 2021). These technologies are now on a path for commercialization, particularly in transit bus, school bus, vocational, and delivery truck applications (Harned 2021). Despite this progress, much work is still needed to bring the LCOD of electrified MHDVs in line with current ICE MHDVs. Some nations (e.g., China and European countries) use financial incentives to promote new technology, but in the United States, financial incentives are used only in the short term (e.g., Tesla is already losing tax incentives on new vehicle purchases). In the United States, widescale technology deployment (and its associated long-term impacts) is contingent upon market acceptance, so new technology must be cost-competitive with the technology it is replacing. Therefore, LCOD is very important to the long-term success of any new technology. Making LCOD calculations, including comparisons between new and current technologies, is key to any MHDV R&D strategy.

### Detailed Vehicle Description

#### Segmentation and Charging Scenarios

---

The ETST has identified ten commercial vehicle segments as “high priority” for electrification assessment, shown in Figure 9. These are listed in rank order of priority and split into two groups: “Significant Fuel Use Reduction” and “Early Adopters & Important Electrification Vocations.” The former group is composed of Class 8 sleeper cab tractors and Class 8 day cab tractors, which use 44.8% and 22.3% of the MHDV fuel respectively, for a total of 67.1% of commercial vehicle fuel use (see Figure 10).

Clearly, reducing commercial vehicle fuel use must include improvements to Class 8 tractor fuel consumption rates. However, Class 8 tractors are one of the most challenging vocations for electrification—and the relevant sectors are among the most risk-adverse. Therefore, those vocations that are more likely to be early adopters of electrification technology will play a critical role in advancing MHDV electrification. Focusing on early adopters will allow technology to be tested and validated in much smaller market segments, thus reducing the risk to an OEM or fleet. The Class 8 vocations are far more likely to embrace a technology that has been proven with an early adopter vocation, especially if the LCOD is competitive with ICE technology.

Lastly, many early adopter vocations can charge their MHDVs in a depot setting, which requires only low-power charging of 50–150 kW DC electric vehicle supply equipment (EVSE) (Bennett, et al. n.d.). This is not the case with most Class 8 vocations. For widespread adoption of electrification technologies in Class 8 tractors, a nationwide high-power charging network will need to be already in place.

Group	Vocation	Body Style	Timeframe (Production / Model Year)
A. Significant Fuel Use Reduction	1. Long-Haul 2. Local Delivery	1. CL 8 Sleeper 2. CL 8 Day Cab	<ul style="list-style-type: none"> <li>• 2020 - baseline</li> <li>• 2025</li> <li>• 2030</li> <li>• 2035</li> <li>• Beyond 2035 - long term</li> </ul>
B. Early Adopters & Important Vocations to consider for Alternative Fuels	3. Pick-up & Delivery 4. Pick-up & Delivery 5. Transit (City) 6. Service Vehicles (Significant Engine Off PTO Usage) 7. General Purpose 8. Heavy Vocational 9. Heavy Vocational 10. School Bus	3. CL 6 Box Truck 4. CL 4 Step Van 5. CL 8 Bus 6. CL 4 or 5 Service  7. CL 3 Pickup 8. CL 8 Dump 9. CL 8 Refuse 10. CL 6/7 School Bus	

Figure 9. Recommended segments and operational conditions for commercial vehicle target setting

Fuel Use					Miles					Population				
rank	Class_body	million DGE	%	cumul %	rank	Class_body	million miles	%	cumul %	rank	Class_body	population	%	cumul %
18	Sleeper Cab	19,024.81	44.8%	44.8%	18	Sleeper Cab	109,324.0	41.0%	41.0%	18	Sleeper Cab	1305953	14.4%	14.4%
28	Day Cab	9,470.86	22.3%	67.1%	28	Day Cab	53,286.2	20.0%	61.0%	28	Day Cab	1091019	12.0%	26.4%
37	Day Cab	1,459.99	3.4%	70.6%	33	Pickup	17,380.1	6.5%	67.5%	33	Pickup	929805	10.2%	36.6%
43	Pickup	1,238.28	2.9%	73.5%	47	Day Cab	9,334.5	3.5%	71.0%	47	Bus, school	451361	5.0%	41.6%
58	Bus, nonschool	1,227.46	2.9%	76.4%	57	Bus, school	5,294.6	2.0%	73.0%	53	Van	366297	4.0%	45.6%
68	Dump	972.21	2.3%	78.7%	68	Dump	4,976.9	1.9%	74.9%	66	Specialty Hauling	274335	3.0%	48.6%
77	Bus, school	755.45	1.8%	80.5%	73	Van	4,768.7	1.8%	76.7%	78	Dump	272703	3.0%	51.6%
86	Box Truck	578.31	1.4%	81.8%	88	Bus, nonschool	4,457.9	1.7%	78.3%	84	Specialty Hauling	266238	2.9%	54.6%
98	Refuse	455.21	1.1%	82.9%	96	Box Truck	4,392.3	1.6%	80.0%	96	Box Truck	262879	2.9%	57.4%
107	Box Truck	433.25	1.0%	83.9%	104	Specialty Hauling	3,686.4	1.4%	81.4%	107	Day Cab	212937	2.3%	59.8%
118	Box Truck	370.55	0.9%	84.8%	118	Box Truck	3,202.9	1.2%	82.6%	117	Box Truck	212163	2.3%	62.1%
124	Specialty Hauling	364.60	0.9%	85.7%	124	Step/Walk-in Van	3,151.5	1.2%	83.7%	126	Dump	198043	2.2%	64.3%
138	Specialty Hauling	359.32	0.8%	86.5%	137	Box Truck	3,115.9	1.2%	84.9%	134	Utility Aerial	182505	2.0%	66.3%
144	Step/Walk-in Van	352.10	0.8%	87.3%	144	Utility Aerial	2,660.4	1.0%	85.9%	148	Box Truck	179568	2.0%	68.3%
154	Utility Aerial	335.76	0.8%	88.1%	156	Specialty Hauling	2,357.7	0.9%	86.8%	157	Dump	163937	1.8%	70.1%
168	Concrete	335.10	0.8%	88.9%	168	Specialty Hauling	2,317.0	0.9%	87.7%	167	Specialty Hauling	161203	1.8%	71.9%
176	Specialty Hauling	330.22	0.8%	89.7%	178	Refuse	2,061.1	0.8%	88.4%	178	Specialty Hauling	158335	1.7%	73.6%
183	Van	318.98	0.8%	90.4%	184	Utility Non-aerial	1,993.1	0.7%	89.2%	185	Specialty Hauling	151257	1.7%	75.3%
197	Dump	239.42	0.6%	91.0%	195	Box Truck	1,480.1	0.6%	89.7%	194	Step/Walk-in Van	147939	1.6%	76.9%
204	Utility Non-aerial	214.25	0.5%	91.5%	207	Specialty Hauling	1,439.8	0.5%	90.3%	205	Box Truck	140692	1.5%	78.4%

Figure 10. Top 20 commercial vehicle body types in rank order by estimates for fuel use, miles, and population

Estimates by NREL from analysis of 2013 IHS Polk vehicle registrations, the 2002 Vehicle Inventory and Use Survey, 2018 data from the American Public Transportation Association, Federal Highway Administration data, and other data sources

## Powertrain Architectures

Figure 2 shows high-level schematics of the powertrains under consideration. Below is a list of these powertrain architectures and the specific features that ETST R&D would examine:

- ▶ Conventional: Incumbent technology (ICE in most cases)
  - Advanced diesel and transmission technologies
- ▶ Mild hybrids: Also referred to as an integrated starter generator
  - Start-stop systems and other low-voltage configurations

- ▶ Full hybrids: Hybrid electric vehicles that combine ICE and BEV systems
  - High-voltage systems that can capture a significant portion of regenerative braking
- ▶ Extended Range Electric: Extended-range electric vehicles, also referred to as a PHEV, in which the battery typically provides most of the energy and ICE is included largely to address range anxiety
  - Different ranges and different ways of depleting the battery
- ▶ Battery electric vehicles: 100% battery-powered
  - Both central and e-axes, as well as different gearing configurations

## Key Assumptions

---

The ETST established the data required as input into the LCOD models. The following were conducted for each vocation:

- ▶ Define the operational requirements
- ▶ Identify the appropriate duty cycle
- ▶ Estimate energy consumption
- ▶ Calculate vehicle and energy levelized cost
- ▶ Run parametric studies to understand sensitivity to cost and other parameters
- ▶ Establish cost targets that would lead to cost parity with ICE vehicles

Powertrain components are sized so that a fully loaded vehicle can meet the performance requirements (for example, starting on a specific grade or traveling a minimum number of miles). The ETST research team has developed a set of requirements for each vocation of interest (see Table 2).

The ETST agrees that waste heat recovery systems are a viable technology for Class 8 long haul vehicles. (These systems have already been demonstrated in the SuperTruck Program.) Therefore, Class 8 long haul conventional powertrain engines will enjoy significantly improved engine peak efficiencies beginning in 2030. However, it is unlikely that a waste heat recovery system would be utilized on a Class 8 regional haul vehicle with a conventional powertrain, as the system technology is expensive and the cost would not be recovered within the required payback period. Therefore, Class 8 regional haul vehicles with conventional powertrains would see only small improvements in engine peak efficiency through 2040 (see Table 2).

The ETST assumes future technology progression for MHDV to be greater for BEV, due to greater R&D focus, than for conventional powertrain equipped vehicles. Additionally, a BEV architecture can enable greater improvement in aerodynamics of the vehicle compared to conventional powertrain-based vehicles. These factors result in a difference in the rate of vehicle improvements, beginning in 2030, between these competing technologies as illustrated in Table 2 below.

Table 2. Key Vehicle Characteristics of Interest

Characteristic	Long/Regional Haul			Class 6 Truck			Class 4 Step Van		
	2020	2030	2040	2020	2030	2040	2020	2030	2040
Engine peak efficiency (%)				44	48	50	44	48	50
Engine peak efficiency (%) – long haul	48.6	55	57						
Engine peak efficiency (%) – regional haul	48.6	51	53.4						
Motor peak efficiency (%)	94	96	96	94	96	96	94	96	96
Inverter peak efficiency (%)	97	98	98	97	98	98	97	98	98
Usable pack energy density (Wh/kg)	158	273	350	158	273	350	158	273	350
Coefficient of drag				0.63	0.55	0.55	0.7	0.65	0.65
Coefficient of drag – conv, ISG, HEV, EREV long haul*	0.52	0.42	0.39						
Coefficient of drag – BEV long haul	0.52	0.42	0.36						
Coefficient of drag – regional haul	0.58	0.50	0.50						
Tire rolling resistance (ton/kg)	5.37	4.9	4.7	5.85	5.58	5.4	5.85	5.58	5.4
Auxiliary load (kW)	3.4	2.6	2	2.5	2.5	2.5	1.5	1.5	1.5
Cargo weight (lbs)	38,000	38,000	38,000	11,200	11,200	11,200	5,700	5,700	5,700
Ownership period (years)	5 / 15	5 / 15	5 / 15	15	15	15	15	15	15
Annual mileage	100,000/ 50,000	100,000/ 50,000	100,000/ 50,000	22,000	22,000	22,000	22,000	22,000	22,000

\* Conventional (conv), integrated starter generator (ISG), hybrid electric vehicle (HEV), extended-range electric vehicle (EREV)

As noted in Medium- and Heavy-Duty vs. Light-Duty Vehicles, MHDVs have variable power needs (e.g., for hydraulic systems). Therefore, it is very important to identify good “reference drive cycles” that can capture additional energy requirements for each vocation. The reference drive cycle does not need to contain each performance requirement; rather, it serves as a model that enables researchers to compare technologies head-to-head in terms of energy usage and LCOD.

The ETST assumed that the battery of any MHDV BEV would last the life of the vehicle for the original designed vocation. In addition, the ETST assumed that the battery would last for one complete shift and would not require a charge until that shift was over.

The ETST assumed that all of the elements considered in this LCOD analysis (energy storage, electrification components and charging infrastructure) have met their “Technical Targets” as defined in this roadmap.

While today’s chassis were designed for conventional powertrains, the ETST could consider both incremental changes to current chassis design and new and specific designs that may provide further opportunity for electrified vehicles. So far, only incremental changes to the current designs have been considered within this roadmap.

For each vocation, researchers also developed a baseline model with a conventional powertrain representing the 2020 model year products currently available in the marketplace.

The Medium- and Heavy-Duty vs. Light-Duty Vehicles section also notes that there may be (limited) opportunities for technology transfer from successful LDV developments, such as improvements to battery cost and performance and electronic components.

## Vehicle Requirements

Vehicle-level requirements for a Class 8 long haul tractor, Class 8 regional haul tractor, Class 6 box truck, and Class 4 step van are listed in Table 3.

**Table 3. High-Level Requirements for Several Vocations**

Vehicle level requirements	Class 8 Long Haul	Class 8 Regional Haul	Class 6 Box Truck	Class 4 Step van
Speed at 6% grade	> 30 mph	> 30 mph	> 45 mph	> 40 mph
Grade at 65 mph	1.25%	1.25%		
Grade at 60 mph			1.50%	1.50%
0-60 mph acceleration	80 sec	80 sec	40 sec	35 sec
0-30 mph acceleration	20 sec	20 sec	14 sec	9 sec
Startability	15%	15%	20%	20%
EV range	500 miles	250 miles	150 miles	150 miles

Representative cycles for each of these four vocations, based on Fleet DNA real-world data, were used to model energy consumption and conduct battery sizing studies (National Renewable Energy Laboratory n.d.b).

## Total Cost of Ownership (TCO) vs. Levelized Cost of Driving (LCOD)

In this analysis, the LCOD has been chosen as the metric to compare the various powertrains. LCOD is a simpler approach than TCO but still works well to compare powertrain technologies. Table 4 defines the difference between TCO and LCOD.

**Table 4. Analysis of the Differences Between TCO and LCOD**

	Parameters	LCOD	TCO
<b>Capital expenses</b>	Vehicle purchase price	yes	yes
	Resale value	yes	yes
	Financing costs	no	yes
	Insurance	no	yes
	Registration	no	yes
	Taxes and incentives	no	yes
<b>Operating expenses</b>	Fuel cost	yes	yes
	Driver wage	no	yes
	Maintenance	no	yes
	Tolls	no	yes
	Charging time penalty	no	yes
	Cargo limit penalty	no	yes

LCOD is made up of two main components, one representing the vehicle cost and one representing the energy cost. Other costs, such as maintenance cost, driver cost, insurance cost, financing cost, and other operating costs, are not considered. The calculation discounts future costs over the ownership period of the vehicle and calculates a resale value at the end of the ownership period. LCOD is expressed in dollars per mile and is based on:

- ▶ Vehicle purchase price
- ▶ Vehicle resale value
- ▶ Yearly mileage
- ▶ Ownership period
- ▶ Price of energy used

A vehicle manufacturing cost is first calculated by adding up the cost of all components. Parameters provided by other tech teams are used to determine the respective component costs (for instance \$/kWh for BEV batteries). The vehicle purchase price is then determined by multiplying the vehicle manufacturing cost by a retail price equivalent (RPE) of 1.2. Resale value is calculated assuming a 15% depreciation year over year. Future expenditures are discounted at 4% per year. Diesel costs are based on the Annual Energy Outlook 2022 after removing federal and state taxes (U.S. Energy Information Administration 2022). In all cases, fuel tax will not be considered in the levelized cost calculation. As a result of uncertainty in future diesel fuel cost, the Annual Energy Outlook is published with High, Reference, and Low figures for the cost of diesel. The ETST has decided to use both the “High” and “Reference” diesel fuel cost in our LCOD analysis because of this uncertainty.

$$LCOD = \frac{\text{vehicle purchase price} - \text{discounted residual value} + \text{discounted energy cost}}{\text{distance}}$$

Battery, motor, and inverter costs used in the LCOD calculations are provided in Table 5.

**Table 5. Battery, Motor, and Inverter Costs**

	2020	2030	2040
Motor cost (based on peak power)	8.90 \$/kW	6.67 \$/kW	6.67 \$/kW
Inverter cost	7.78 \$/kW	6.67 \$/kW	6.67 \$/kW
Battery cost (pack-level cost)	270 \$/kWh	84 \$/kWh	56 \$/kWh

## Technical Targets

### Levelized Cost of Driving

The Powertrain Systems Architecture (PSA) team gathered inputs from all tech teams and used Autonomie to calculate the LCOD for the selected applications (Vehicle Systems and Mobility Group n.d.). The analysis serves as a platform to discuss the assumptions and determine where improvements may be required for a specific powertrain to become competitive. Defining component technology and cost levels that provide cost parity between powertrain options is of particular interest.

#### Factors Outside 21CTP Control

---

- ▶ Cost of electricity
- ▶ Cost of diesel fuel
- ▶ New technology adoption rate
- ▶ New technology infrastructure availability (electric and/or hydrogen) – impacts adoption rate
- ▶ New technology reliability – impacts adoption rate

#### LCOD Technology Analysis

---

All technology and cost values are specifically defined except for the cost of electricity and the cost of diesel fuel, where a range of low and high values were considered.

The figures in the Appendix A – Levelized Cost of Driving (LCOD) Analysis show LCOD values for all five powertrains of interest (listed and described in Powertrain Architectures) for the baseline year (2020) and target LCOD values for the next two ten-year increments (2030 and 2040). Each figure highlights the vehicle cost contribution as well as the energy cost contribution.

A sensitivity analysis was also conducted on long haul trucks to understand how diesel price, electricity price, and battery cost impact the LCOD. For a given percentage change in any of those three dimensions, the LCOD is most sensitive to diesel price, then electricity cost, and finally battery cost.

These same data can also be illustrated as a line graph. Figure 11–Figure 14 below illustrate the conventional diesel drive train vs. the BEV drive train for years 2020 to 2040. Note: The LCOD calculations are shown as a range, as the “cost of electricity” and “cost of diesel fuel” are displayed in a sensitivity range.

For both Class 4 and Class 6 trucks, the combination of duty cycle, engine efficiency, and diesel cost is such that the energy cost of conventional vehicles is higher than that of BEVs. The higher BEV cost can then be offset with energy cost savings. However, this is not the case for long haul and regional haul applications, which benefit from a higher engine peak efficiency and a duty cycle that allows the engine to operate mainly in high-efficiency areas.

## Class 8 Long Haul

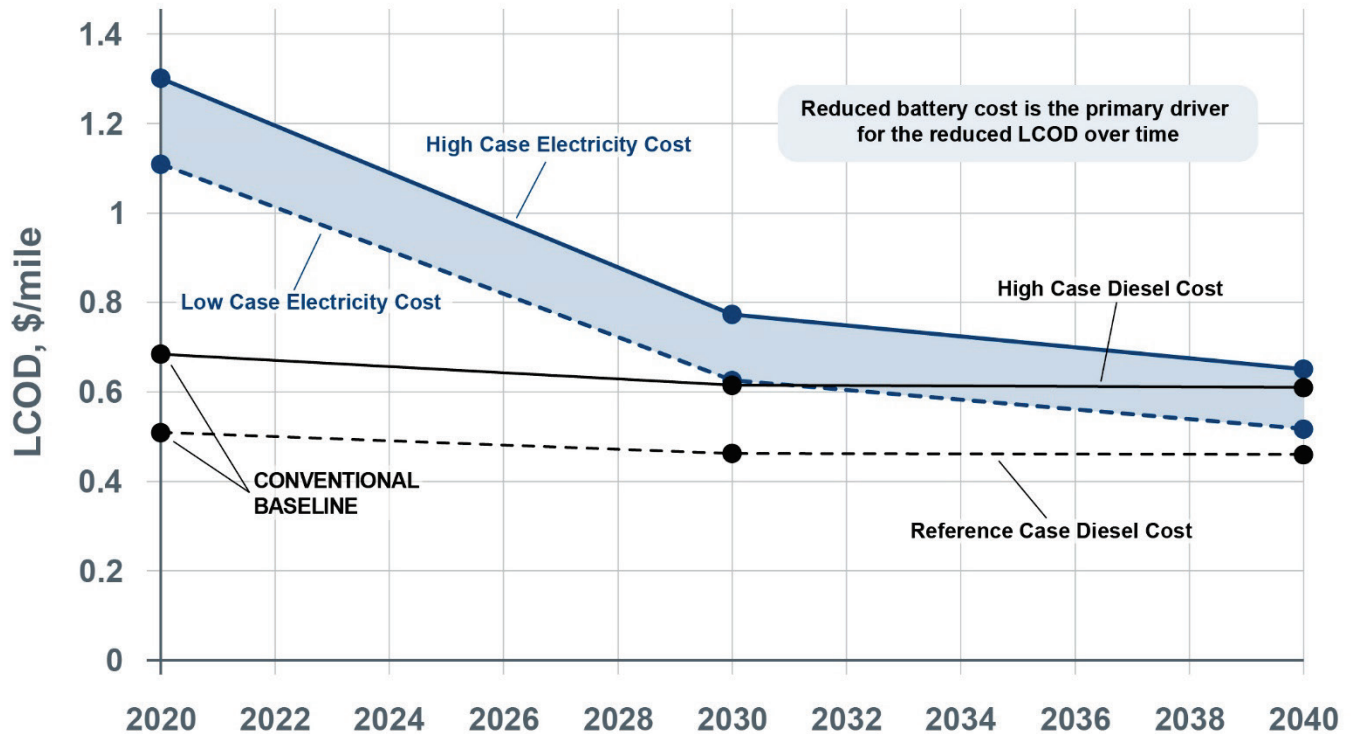

Figure 11. Conventional vs. BEV drive train for 2020–2040 for Class 8 long haul

**Class 8 long haul tractor.** Highly electrified powertrains (EREV and BEV) remain more expensive to drive, as both vehicle cost and energy cost are higher than those of conventional vehicles through 2030. However, with the current set of assumptions, electric Class 8 long haul tractor–trailer combination trucks may be able to compete with conventional trucks by 2040 if LCOD is the sole consideration.

## Class 8 Regional Haul

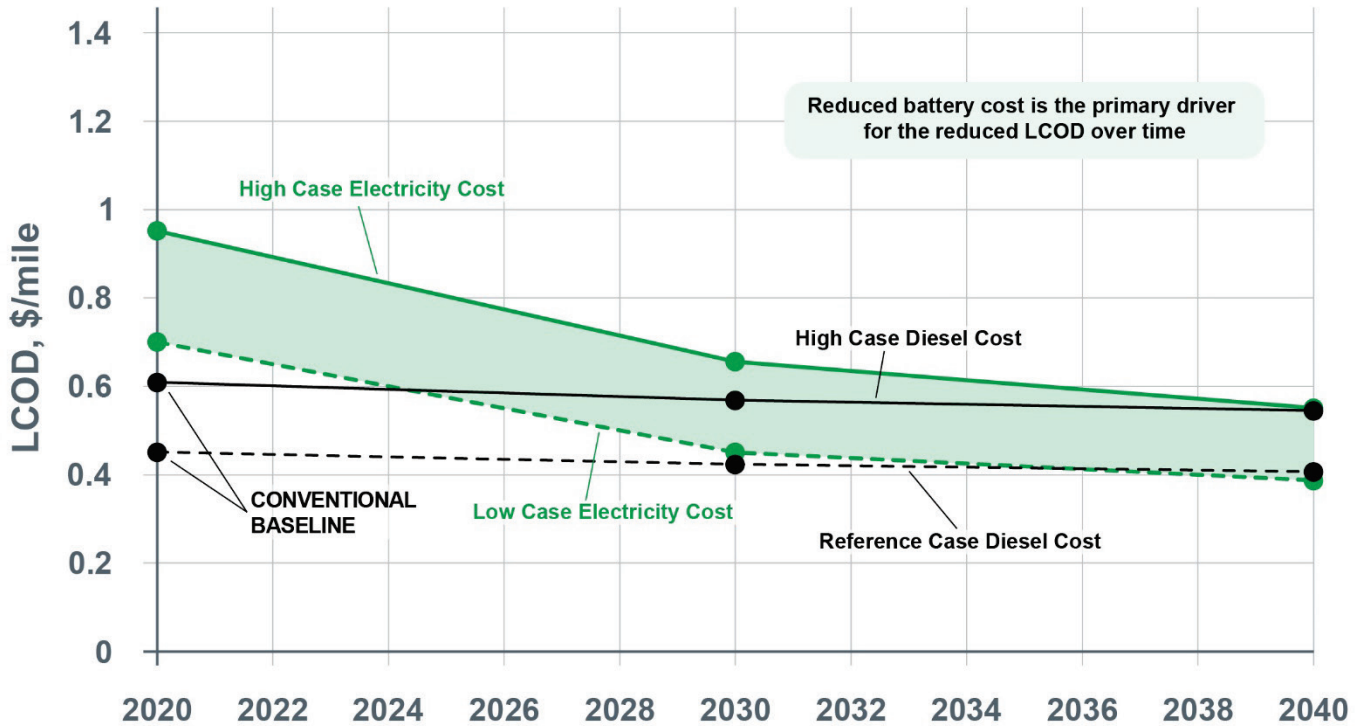

Figure 12. Conventional vs. BEV drive train for 2020–2040 for Class 8 regional haul

**Class 8 regional haul tractor.** Highly electrified powertrains (EREV and BEV) are currently more expensive to drive, as both vehicle cost and energy cost are higher than those of conventional vehicles. However, with the current set of assumptions, electric Class 8 regional haul tractor–trailer combination trucks may be able to compete with conventional trucks by 2030 if LCOD is the sole consideration. Although the cost delta between conventional vehicles and BEVs is less than that of the long haul vehicle, BEVs remain more expensive than conventional vehicles throughout the timeframe considered. As with the long haul truck, the electrification option is not attractive in the near term.

## Class 6 Box Truck

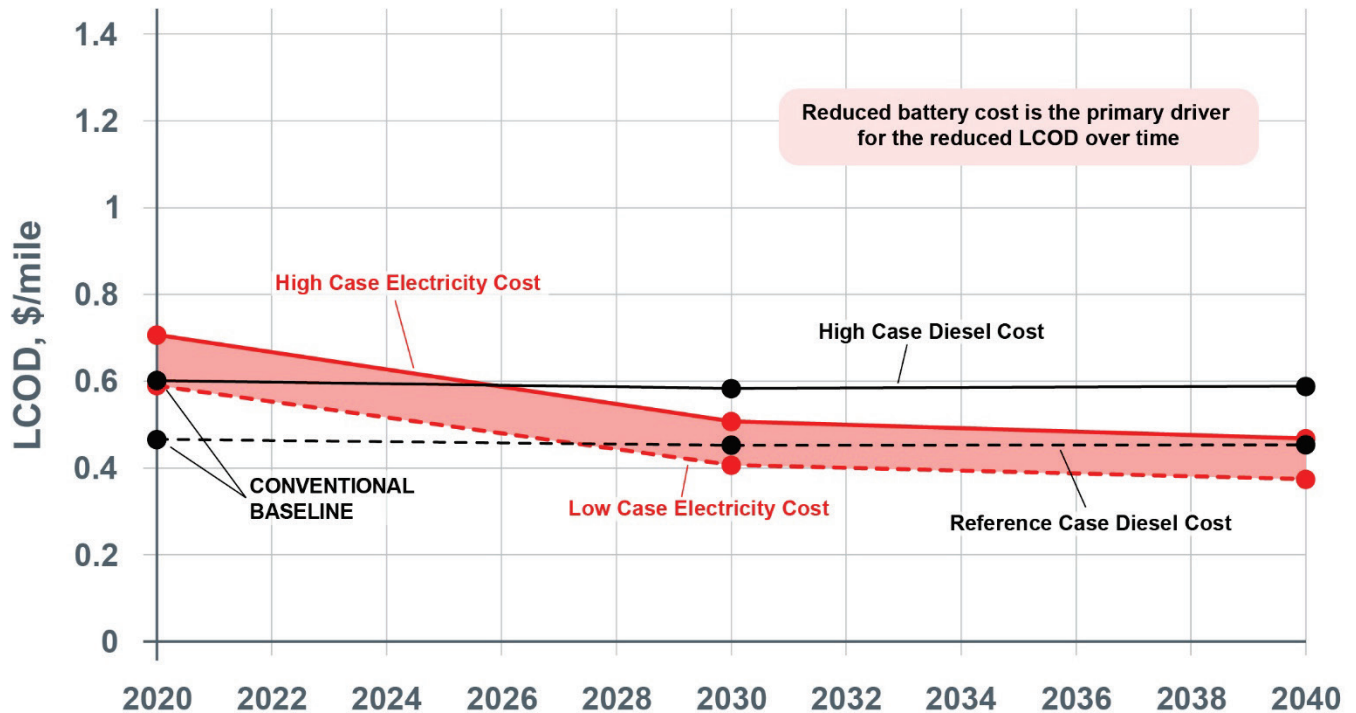

Figure 13. Conventional vs. BEV drive train for 2020–2040 for Class 6 box truck

**Class 6 box truck.** The average BEV LCOD value is shown to be on par with or lower with than conventional vehicles from 2030 onwards. The case for electric medium-duty vehicles is more compelling, with Class 6 box trucks showing potential cost parity in 2030 and beyond.

## Class 4 Step Van

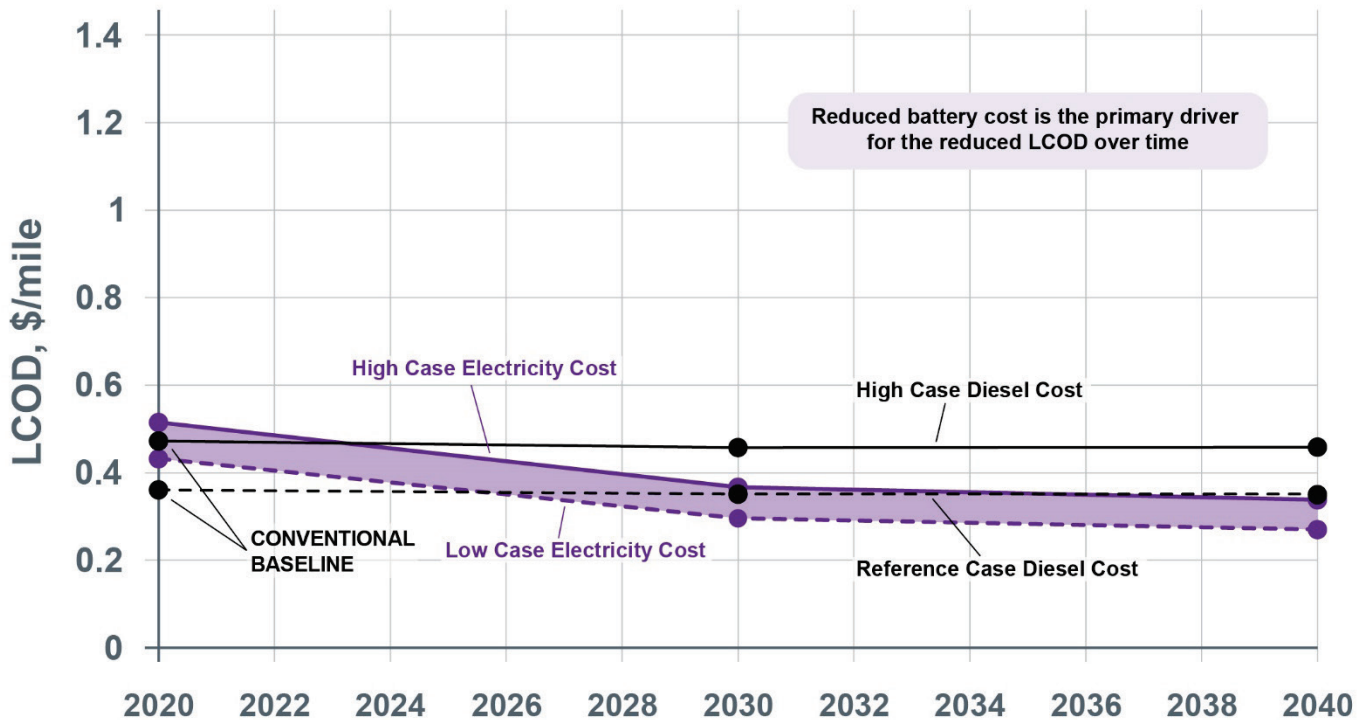

Figure 14. Conventional vs. BEV drive train for 2020–2040 for Class 4 step van

**Class 4 step van.** The average BEV LCOD value is lower than that of a conventional vehicle from 2030 onwards.

There are two primary reasons why the BEV drive train is not very attractive for both Class 8 regional haul and long haul:

- ▶ ICE engine peak efficiency is estimated to be 55% and 59% in 2030 and 2040 respectively. Given the duty cycles at high speed (mostly 60~70 mph on a highway), the engine operates at a high efficiency point for most of the duty cycle.
- ▶ Electricity cost assumptions have recently been estimated by the Infrastructure WG for high power charging. These estimates show that higher-power charging for en route charging scenarios, which are likely to dominate in Class 8 operation, may result in higher costs of electricity due to infrastructure upgrade, equipment, and other costs.

The consequence is that the energy related cost (diesel for conventional and electricity for diesel) is actually higher for the BEV. We end up in a situation with the Class 8 BEV's where both vehicle cost and fuel costs are higher than a conventional drive train.

## Electrical Energy Storage

This section provides targets for Class 8, Class 6, and Class 4 battery electric tractors and trucks, based on the expected needs for range, grade, and cargo.

Class 8 line-haul tractor targets are set forth in Table 6. The large pack size compared to LDVs enables lower specific discharge power and volumetric energy density targets. A 10-year, 2,000-cycle lifetime is needed to satisfy MHDV extended life requirements, which include an average of 14 years and 1,000,000 miles (Oak Ridge National Laboratory and National Renewable Energy Laboratory 2019). The temperature range targets remain the same as the analogous LDV targets set by the U.S. Advanced Battery Consortium (USABC), reflecting the similar operational window of these vehicles. Current battery technology can meet the Class 8 power targets listed in Table 6, but fall short on specific energy and energy density. Additional work will need to be done to achieve higher-energy electrode materials.

**Table 6. Preliminary Battery Requirements**

End-of-Life Characteristics at 30°C	Units	Class 8 Long Haul		Class 6 Box Truck		Class 4 Step Van	
		Target Year 2020	Target Year 2030	Target Year 2020	Target Year 2030	Target Year 2020	Target Year 2030
Peak Discharge Power (30 sec)	kW	600	600	265	265	220	220
Discharge Power (30 minute)	kW	500	500	200	200	165	165
Peak Discharge Power Density (30 sec) (Cell†/System*)	W/L	359/162	741/333	535/241	535/241	529/238	529/238
Peak Specific Discharge Power (30 sec) (Cell†/System**)	W/kg	172/121	260/182	414/290	576/405	444/310	571/400
Peak Regen Specific Power (10 sec)	kW	480	480	212	212	176	176
Regen Power (continuous)	kW	400	480	160	160	132	132
Peak Regen Power Density (10 sec) (Cell†/System*)	W/L	288/129	593/267	428/193	428/193	423/190	428/193
Peak Specific Regen Power (10 sec) (Cell†/System**)	W/kg	138/96	208/145	331/232	461/324	355/248	457/320
Useable Energy	kWh	900	900	165	900	165	900
Useable Energy Density (Cell†/System*)	Wh/L	539/243	1,111/500	333/150	333/150	308/139	308/139
Useable Specific Energy (Cell†/System**)	Wh/kg	258/181	390/273	258/180	359/252	258/181	332/233
Calendar Life	Years	10	20	20	20	20	20
Dynamic Stress Test (DST) Cycle Life	Cycles	2,000	2,000	2,400	2,400	2,400	2,400
Cell Cost	\$/kWh	145	75	145	75	145	75
Normal Recharge Time	Hours	6					

End-of-Life Characteristics at 30°C	Units	Class 8 Long Haul		Class 6 Box Truck		Class 4 Step Van	
		Target Year 2020	Target Year 2030	Target Year 2020	Target Year 2030	Target Year 2020	Target Year 2030
High Rate Charge (in 30 minutes) (60%SOC)	kWh	540	540	99	99	99	99
Minimum Operating Voltage	V	0.55*Vmax					
Unassisted Operating Temperature Range (30 sec)	°C	-30 to +52					
+20°C to +52°C	% Power	100					
0°C	% Power	50					
-10°C	% Power	30					
-20°C	% Power	15					
-30°C	% Power	10					
Survival Temperature Range, 24 hours	°C	-40 to +66					
Maximum Self-Discharge	%/month	<1					
Maximum Volume (Cell <sup>†</sup> /System <sup>*</sup> )	L	1669/3709	810*/1800	495/1100	495/1100	416/924	416/924
Maximum Weight (Cell <sup>‡</sup> /System <sup>**</sup> )	kg	3485/4979	2310**/3300	640/914	460/655	496/709	385/550

† Mass and volume scaling based on cell level parameters

‡ Total mass and volume used by cells in the system

\* Total cell volume based on 45% cell to pack volume ratio

\*\* Total cell weight based on 70% cell to pack mass ratio

Class 6 box truck targets and Class 4 step van targets are also set forth in Table 6. As with the Class 8 targets listed above, the large pack size (relative to LDVs) enables lower specific discharge power and volumetric energy density targets. For both the Class 6 and Class 4 vehicles, 20-year, 2,400-cycle lifetimes are needed to satisfy extended life requirements. Ranges are lower than for Class 8, resulting in lower specific energy and energy density targets. The temperature range targets remain the same as the analogous LDV targets set by USABC, reflecting the similar operational window of these vehicles. Current battery technology can meet both the Class 6 and Class 4 power targets and energy density targets listed in Table 6 but fall short on specific energy. Advanced materials are currently being developed that will likely be able to meet most of the performance targets, but life will need to be evaluated.

## Charging/Infrastructure

As vehicle electrification expands from the light-duty sector to include larger MHDVs, businesses will have to decide whether electrification is appropriate for their fleets. One of the key factors in this decision will be the LCOD, as highlighted previously in this roadmap. Most light-duty fleet applications are best served through the use of AC Level 2

charging defined by the Society of Automotive Engineers (SAE) J1772 standard (Bennett et. al. 2019). However, as outlined in a recent study by NREL, MHDVs require more energy than LDVs and therefore rely on more powerful DC charging technologies to keep charging time to a cost-effective level. Installing and operating these high-power chargers increases the cost of charging per unit of energy (Borlaug et al. 2021).

To understand the likely cost of delivered energy to charge MHDVs, the NREL study follows an analysis framework to estimate the breakeven cost to charge. The analysis considers a wide range of factors. The study estimates electric vehicle adoption trajectories and analyzes real-world fleet data to assess energy needs of these vehicles and to determine expected charging station demand over time. Station demand informs the level of EVSE deployment necessary at each location, as well as the site utilization and electricity demand profile. The study accounts for a wide range of capital investments, operating costs, and other expenses. All these inputs are used to determine a breakeven cost of energy.

This framework is applied to multiple scenarios, accounting for a wide range of applications and situations. The scenarios are primarily defined by station type: Depot, Rest Area (Travel Center), and En Route. Depot operations include vehicle charging that occurs at company-owned facilities, sometimes referred to as “behind the fence” charging. It is assumed that depot charging will occur during longer dwell periods (charging time) and will be owned and managed by the fleet owner for the vehicles that regularly dwell at these locations. On the other hand, travel centers and en route locations represent public stations offering charging services for MHDVs. Travel centers will also serve charging needs of vehicles with long dwell periods and therefore will offer EVSE with charging power similar to that of depots. However, en route locations will serve a broader range of charging needs, offering the highest-powered EVSE for shorter dwell periods, as well as lower-power EVSE similar to the depots and travel centers.

For each of these location types, the study considered a series of scenarios. The parameters for each location type are presented in the tables below. Station utilization refers to how often the EVSEs at the location are in use. Installation costs are the capital expenses incurred to develop a charging location, including items such as the EVSE, site infrastructure, and utility upgrades. Table 10 provides the final cost of electricity that results from the various scenario calculations. The analysis within the report illustrates costs with the identified assumptions in the high utilization depot case are \$0.17/kWh and in the low utilization en route case of \$0.38/kWh. These results demonstrate that many different factors—including the charging scenario, utility rates, and utilization rates—can have significant impacts on charging costs for MHDVs.

The NREL report goes into significant detail regarding the assumptions and methodology that was used for the final cost of electricity and can be referenced if more detail is required. Though it’s important to highlight that the cost is particularly sensitive to the electricity rate structure and the utilization at a given site. The analysis in the report considered variation in these factors by leveraging two representative rate structures with high and low utilization rates which are identified in tables 6, 7, and 8. Rate structures for charging can vary drastically, as identified in Muratori, Kontou, and Eichman 2019, where demand charges were noted to exceed \$25/kW but are typically less than \$15/kW and energy charges are below \$0.20/kWh for most cases. The costs in this report help to illustrate the diversity in cost of charging but should not be interpreted to be definitive of the minimum and maximum costs for all situations.

Table 7. Depot Charging Parameter Assumptions

EVI-FAST Parameter	Depot "Slow"	Depot Fleet 3 Food Delivery 50 Tractors High Ut, High Grid	Depot Fleet 2 Warehouse 20 Tractors Low Ut, High Grid	Depot Fleet 3 Food Delivery 50 Tractors High Ut, Low Grid	Depot Fleet 2 Warehouse 20 Tractors Low Ut, Low Grid	
Installation Information						
EVSE Unit Power (kW)			150	50	150	50
Site Capacity (kW)			3,600	950	3,600	950
EVSE Unit Quantity			24	19	24	19
Peak Demand (kW)			3,600	950	3,600	950
Unit Pricing (\$/kW)			\$300	\$383	\$416	\$519
Charging Equipment Cost (\$/unit)			\$1,079,000	\$364,000	\$1,496,000	\$493,000
Distribution Upgrades (\$)			\$945,000	\$50,000	\$2,445,000	\$60,000
Installation Price (\$/kW)			\$750/kW	\$420/kW	\$1,080/kW	\$750/kW
Onsite Installation Cost (\$)		\$2,700,000	\$399,000	\$3,888,000	\$713,000	
Annual Maintenance Cost (\$/year)		\$77,000	\$61,000	\$77,000	\$61,000	
Utilization						
Operational Life (EVSE)		10	10	10	10	
Operational Life (Install/Service Equipment)		40	40	40	40	
Installation Time (months)		9	3	12	3	
Electricity Consumption Rate (kWh/kWh)		1.176	1.176	1.176	1.176	
Demand Ramp-up (years)		2	2	2	2	
Long-Term Nominal Utilization		19.4%	17.6%	19.4%	17.6%	
Operating Expenses						
Energy Charges (\$/kWh)		\$0.03 - \$0.065	\$0.03 - \$0.065	\$0.03 - \$0.065	\$0.03 - \$0.065	
Demand Charges (\$/kW)		\$5/\$15	\$5/\$15	\$5/\$15	\$5/\$15	
Grid Operations/Service (\$/year)		\$1,890.00	\$1,890.00	\$1,890.00	\$1,890.00	
Land Requirements (acres)		2.10	1.20	2.10	1.20	
Land Costs (\$/acre/yr) = (\$/acre)/8		\$ —	\$ —	\$ —	\$ —	

\* Ut = utilization

Table 8. Rest Area (Travel Center) Charging Parameter Assumptions

EVI-FAST Parameter	Rest Area	Rest Area R450 High Ut, High Grid	Rest Area R450 Low Ut, High Grid	Rest Area R450 High Ut, Low Grid	Rest Area R450 Low Ut, Low Grid	
Installation Information						
EVSE Unit Power (kW)			150	150	150	150
Site Capacity (kW)			1500	1500	1500	1500
EVSE Unit Quantity			10	10	10	10
Peak Demand (kW)			1,764	1,764	1,764	1,764
Unit Pricing (\$/kW)			299.72	299.72	415.68	415.68
Charging Equipment Cost (\$/unit)			\$449,580	\$449,580	\$623,520	\$623,520
Distribution Upgrades (\$)			\$945,000	\$50,000	\$2,445,000	\$60,000
Installation Price (\$/kW)			\$750/kW	\$750/kW	\$1,080/kW	\$1,080/kW
Onsite Installation Cost (\$)		\$1,125,000	\$1,125,000	\$1,620,000	\$1,620,000	
Annual Maintenance Cost (\$/year)		\$32,000	\$32,000	\$32,000	\$32,000	
Utilization						
Operational Life (EVSE)		10	10	10	10	
Operational Life (Install/Service Equipment)		40	40	40	40	
Installation Time (months)		6	6	9	9	
Electricity Consumption Rate (kWh/kWh)		1.176	1.176	1.176	1.176	
Demand Ramp-up (years)		12	18	12	18	
Long-Term Nominal Utilization		20%	20%	20%	20%	
Operating Expenses						
Energy Charges (\$/kWh)		\$0.03 - \$0.065	\$0.03 - \$0.065	\$0.03 - \$0.065	\$0.03 - \$0.065	
Demand Charges (\$/kW)		\$5/\$15	\$5/\$15	\$5/\$15	\$5/\$15	
Grid Operations/Service (\$/year)		\$1,890	\$1,890	\$1,890	\$1,890	
Land Requirements (acres)		0.80	0.80	0.80	0.80	
Land Costs (\$/acre/yr) = (\$/acre)/8		\$20,000	\$20,000	\$20,000	\$20,000	

Table 9. En Route Charging Parameter Assumptions

EVI-FAST Parameter	En-Route "Fast and Slow" R450 80th	En-Route 1+ MW High Ut, High Grid	En-Route 150 kW High Ut, High Grid	En-Route 1+ MW Low Ut, High Grid	En-Route 150 kW Low Ut, High Grid	
Installation Information						
EVSE Unit Power (kW)		3,000	150	3,000	150	
Site Capacity (kW)		42,000	3,900	21,000	1,350	
EVSE Unit Quantity		14	26	7	9	
Peake Demand (kW)		~	—	~	—	
Unit Pricing (\$/kW)		\$300	\$300	\$300	\$300	
Charging Equipment Cost (\$/unit)		\$12,600,000	\$1,169,000	\$6,300,000	\$405,000	
Distribution Upgrades (\$)		\$10,000,000	\$—	\$5,000,000	\$—	
Installation Price (\$/kW)		\$65/kW	\$750/kW	\$65/kW	\$750/kW	
Onsite Installation Cost (\$)		\$2,730,000	\$2,925,000	\$1,365,000	\$1,012,500	
Annual Maintenance Cost (\$/year)		\$44,800	\$83,200	\$22,400	\$28,800	
Utilization						
Operational Life (EVSE)		10	10	10	10	
Operational Life (Install/Service Equipment)		40	40	40	40	
Installation Time (months)		12	12	9	9	
Electricity Consumption Rate (kWh/kWh)		1.176	1.176	1.176	1.176	
Demand Ramp-up (years)		10	10	15	15	
Long-Term Nominal Utilization		9.53%	9.78%	6.10%	10.67%	
Operating Expenses						
Energy Charges (\$/kWh)	\$0.03 - \$0.065	\$0.03 - \$0.065	\$0.03 - \$0.065	\$0.03 - \$0.065		
Demand Charges (\$/kW)	\$5/\$15	\$5/\$15	\$5/\$15	\$5/\$15		
Grid Operations/Service (\$/year)	\$1,890	\$1,890	\$1,890	\$1,890		
Land Requirements (acres)	1.00	1.50	0.50	0.50		
Land Costs (\$/acre/yr) = (\$/acre)/8	\$25,000	\$37,500	\$12,500	\$12,500		

Table 10. Cost of Electricity Results from Various Scenarios

Scenario	EVSE Power	Breakeven Cost (\$/kWh Real 2025\$)	
		Low	High
Depot (private)	50-150 kW	\$0.17	\$0.27
Rest Area (public)	151 kW	\$0.20	\$0.31
En Route (public)*	3 MW	\$0.18	\$0.38
	150 kW	\$0.22	\$0.19

\* En route costs are results for same scenario (3 MW/150 kW pairs) defined by the lowest and highest MW costing

Table 11. Weighted Cost of Electricity by Vocation Used in the PSA WG LCOD Analysis

Vocation	Charging Scenario Assumption	Weighted Breakeven Cost (\$/kWh Real 2025\$)	
		Low	High
Class 8 Local	80% Depot (kW), 20% En Route (MW)	\$0.17	\$0.27
Class 8 Regional Haul	60% Depot (kW), 40% En Route (MW)	\$0.20	\$0.31
Class 8 Long Haul	45% Rest Area (kW), 55% En Route (MW)	\$0.18	\$0.38
Class 6 Box Truck	100% Depot (kW)	\$0.22	\$0.19
Class 4 Step Van	100% (kW)	\$0.22	\$0.19

## Electrification Components

The main components of an electric drive are the traction inverter and motor, which can have energy supplied by a battery or a fuel cell. An electric motor consists of a magnetic steel stator with copper windings, while the rotor consists of magnetic steels and either magnets or copper windings. An inverter, on the other hand, has far more components in capacitors, power modules, heat sinks, controllers, gate drivers, and sensors.

**Table 12. Technical Requirements for Traction Drive**

Characteristic	Class 8 Baseline	Class 8 2030	Class 6 Baseline	Class 6 2030
<b>Traction Drive</b>				
Continuous traction drive power	385 kW	385 kW	175 kW	175 kW
Peak traction drive power	530 kW	530 kW	250 kW	250 kW
Durability/lifetime – B10	No commercially available vehicles	1M miles (25,000 hours)	450K miles	550K miles
Volumetric power density (kW <sub>peak</sub> /l)	2.68	3.3	2.1	4.5
Gravimetric power density (kW <sub>peak</sub> /kg)	2	3.1	1.6	3.5
Cost/peak power (\$/kW <sub>peak</sub> )	16.7	13.4	15.6	13.4

**Table 13. Technical Requirements for Inverter**

Characteristic	Class 8 Baseline	Class 8 2030	Class 6 Baseline	Class 6 2030
<b>Inverter</b>				
Inverter mass	30 kg	25 kg	17 kg	13.9 kg
Inverter volume	30 liters	15 liters	17 liters	8.33 liters
Inverter rated (cruising operation point) efficiency	>97%	>98%	>97%	>98%
Inverter cost	\$4100	\$3500	\$2000	\$1670
DC link voltage	700 V nominal	1200 V nominal	700 V nominal	1200 V nominal
Volumetric power density (kW <sub>peak</sub> /L)	18.3	36.7	14.7	30
Gravimetric power density (kW <sub>peak</sub> /kg)	18.3	22	14.7	18
Cost/peak power (\$/kW <sub>peak</sub> )	7.8	6.7	7.8	6.7

Table 14. Technical Requirements for Motor

Characteristic	Class 8 Baseline	Class 8 2030	Class 6 Baseline	Class 6 2030
<b>Motor</b>				
Continuous torque level	1200 Nm	1200 Nm	480 Nm	480 Nm
Peak (stall) torque level	2000 Nm	2000 Nm	800 Nm	800 Nm
Time to sustain this torque	30 sec	120 sec	30 sec	120 sec
Motor mass	250 kg	150 kg	140 kg	57 kg
Motor volume	175 liters	150 liters	97 liters	47 liters
Motor rated (cruising operation point) efficiency	>90%	>96%	>90%	>96%
Motor cost	\$4700	\$3500	\$2200	\$1670
Maximum speed	<10,000 rpm	>12,000 rpm	<10,000 rpm	>12,000 rpm
Constant power speed range	>3	>3	>3	>3
Volumetric power density (kW <sub>peak</sub> /L)	3.1	3.7	2.6	5.3
Gravimetric power density (kW <sub>peak</sub> /kg)	2.2	3.7	1.8	4.4
Cost/peak power (\$/kW <sub>peak</sub> )	8.9	6.7	8.9	6.7

## Technical Gaps and Barriers

### Powertrain Systems Architecture

To build confidence in the energy consumption and LCOD models, three areas are of particular importance:

- ▶ Vehicle performance requirements and a reference drive cycle for each vocation
- ▶ Model validation to real life
- ▶ Consistent use of assumption data across all 21CTP: energy cost, drive cycles, cost of components, etc.

### Vehicle Performance Requirements and a Reference Drive Cycle

---

The key vehicle requirements that are driving powertrain development and cost can vary depending on the powertrain. While a key requirement of conventional powertrains is engine power, the primary requirements of MHDV electric powertrains is likely to be range and charging time in addition to continuous power. This highlights the need to revisit how vocations and drive cycles are quantified and analyzed. Survey and drive cycle data collection will play a key role in shaping the requirements of new powertrain options.

Vehicle performance requirements and the drive cycle for a given application may vary significantly for different customers. For conventional powertrains, different engine, transmission, or final drive options are offered to suit every customer's requirements. The increase in e-commerce and the emergence of new warehouses closer to customers to facilitate last-mile deliveries have led to changes in freight patterns, which, in turn, have impacts on how vehicles are used. An understanding of the variability in customer usage is critical to developing new powertrain options that meet all customer requirements. However, the ETST will establish only one reference drive cycle for each vocation so that technologies can be compared.

### Model Validation

---

DOE has made significant investments in the development of tools to predict the energy impact of new powertrain technologies. Over the years, the models have been thoroughly validated on a wide range of passenger vehicles and powertrain options and are still being validated when new passenger cars are tested on a chassis dynamometer. Validation includes not only aggregate fuel consumption numbers but also time behavior of all major powertrain components. For commercial vehicles, the models have been validated against publicly available energy consumption data for both conventional and electrified powertrains. However, the lack of detailed vehicle test data is such that a thorough validation has so far been limited. Access to vehicle test data and/or the collection of vehicle data is necessary to do a detailed validation and build confidence in the model predictions for each of the highlighted 10 vocations.

## Consistent Use of Assumption Data across All 21CTP Technical Teams and Working Groups

---

Each year, we learn more about actual energy cost, component cost, drive cycles, etc. It will be important to have one repository for all the “assumption data” going into the ETST computer models going forward, and this repository will need to be updated regularly. This will ensure that all the Tech Teams and Working Groups are starting their analyses with consistent assumption data.

### Electrical Energy Storage

The primary barriers for electrical energy storage systems include achieving high power densities with high available energy, reliability, safety, and cycle life. Battery and life cycle costs are critical issues that could influence market acceptance for heavy vehicle applications. Many battery materials are currently too expensive or are not readily available in the United States. The chemicals used in many types of batteries need to be more stable to avoid self-discharge. Long, shallow discharges can cause chemical instability. The chemistry and materials in each technology can be improved. Lithium-ion batteries have potential safety issues. Other barriers are proper integration of batteries in a pack within the vehicle, thermal management, and control systems.

The barriers set forth below apply broadly across medium- and heavy-duty truck applications, but will vary in priority depending on truck size, vocation, and drive cycle profile, which will determine battery chemistry.

#### Cost, Status

---

Battery cost is a primary barrier to widescale electrification. VTO R&D had lowered the cost of vehicle battery packs to \$185/kWh in 2019, an ~80% reduction since 2008 based on useable pack energy, but further cost reduction is needed to achieve cost-competitiveness with conventional vehicles (Boyd 2020). The primary drivers of battery cost at present are expensive raw materials (including low abundance materials such as Co, high-purity materials such as Ni and graphite, and/or foreign-controlled materials), materials processing costs, cell and module packaging, and manufacturing costs. Costs continue to decrease towards the \$75/kWh target as cheaper alternative materials are incorporated and as increased manufacturing volume reduces material and manufacturing costs.

Developing cells with high energy would reduce costs; however, cell chemistries that provide higher energy have life and performance issues.

#### Performance

---

There are many aspects of battery performance that must be improved to meet demands for MHDV applications. Increasing volumetric and gravimetric energy density are vital owing to the need to accommodate cargo and a large, heavy battery pack. Furthermore, vehicle size and drive cycles require higher energy and power requirements: 4 times the peak torque, more than 5 times greater per-mile fuel consumption, and gross vehicle weights up to 80,000 pounds for on-road vehicles (higher for off-road vehicles) (Oak Ridge National Laboratory and National Renewable Energy Laboratory 2019). Although initial power will exceed the required peak power for MHDVs, its decay with cycling tends to be more precipitous than capacity (energy) and will bring about end of useful life for the battery pack.

Existing chemistries (graphite anodes paired with transition metal oxide cathodes) need improvement in fast charge capability and low-temperature performance to match ICE vehicles and improve customer convenience.

## Life

---

Although mature lithium-ion battery technology can largely satisfy lifetime targets for LDVs, the longer expected lifetime of MHDVs will likely require improved battery materials and operating conditions (e.g., upper voltage limit, charge rate, etc.) as appropriate for vehicle vocation and drive cycle. Higher-energy-density materials, such as Li-metal and Si anode batteries, presently suffer from shortened life due to loss of active material (Li plating, dendrite formation or Si cracking, loss of contact). At this time, anodes containing a large fraction of Si do not meet calendar life targets.

Meeting consumer needs for fast charging is also critical to success, and increased charge rates typically decrease battery life. Fast charging will be a higher priority for some MHDV applications.

## Abuse Tolerance

---

The lithium-ion battery chemistries currently on the market are susceptible to self-ignition. Additional cost would be required to ensure the batteries operate safely and meet energy and power demands of MHDVs. Special precautions must be taken because of pack size, especially to prevent thermal propagation. These safeguards might include using non-flammable electrolytes and determining safety via failure testing to attain a certain European Council for Automotive R&D (EUCAR) rating. The ability to repair/replace modules based on module diagnostics could keep trucks on the road longer with minimal cost/maintenance time.

## Recycling and Sustainability

---

With MHDV electrification, expensive and/or rare materials, especially Li, Co, and Ni, will be consumed in increasing quantities to meet scale-up needs for MHDV transportation. This future trend suggests the need for economical end-of-life solutions for these batteries. Battery recycling currently focuses on the cathode materials (especially Co). Further cost reduction for recycling and increase in its scale to encompass most used battery materials is critical to a sustainable approach to MHDV electrification. Improved recycling processes could significantly reduce battery electric truck lifecycle cost, prevent or ameliorate material shortages, reduce the environmental impact of new material production, and ideally, provide low-cost active materials for new battery manufacturing.

## Modular Design

---

Modular design and the ability to replace individual modules rather than the entire battery back would contribute significantly to the overall maintenance cost and sustainability of battery electric trucks, particularly for vehicles with especially long range and heavy cargo hauling needs, where battery packs could be up to 1 MWh.

## Charging/Infrastructure

Access to more high-power chargers will be required to alleviate range anxiety for MHDV PHEV and BEV users without adding multiple charging stops that would significantly increase travel times. High-power charging at the megawatt level enables MHDV electrification by ensuring that drivers can complete their existing routes without excessive delay. Charging at such a high-power level allows electric vehicle recharging at a duration approaching parity with their ICE counterparts. Installing infrastructure capable of such high-power charging will be expensive but is crucial to meeting the operational requirements of all MHDVs.

## Electrification Components

Battery power density has improved such that it is no longer a significant technical barrier. However, reliability is still an issue in MHDV requirements, which often call for lifetimes of 1,000,000 miles in harsh environments.

Other barriers are thermal management systems for fast, energy-efficient heat removal from device junctions and components, control of electromagnetic interference generated when the devices are switched, and a low-inductance package for the power inverter. Generally, silicon operates too cold for efficient heat removal if the power electronics cooling system draws coolant from the engine, which would expose the electronics to relatively high water–ethylene glycol temperatures. As a result, silicon carbide is a preferred technology for more efficient heat removal. The task of packaging power electronics to satisfy the multiple extreme environments and ensuring reliable operation with proper function is a barrier. (The packages that are available are generally not suitable for vehicle applications.) Additionally, there is a limited domestic supplier base for high-power switch devices.

## Electric Motors

The U.S. DRIVE Partnership (U.S. DRIVE) has set technical targets for electric motors when used in LDV BEVs. Unfortunately, many of these targets will not apply to MHDV BEVs. For example, MHDV BEVs will require higher power levels, higher torques at zero speed, improved partial load efficiency, longer stall torque availability, higher torque density (LDVs need higher power density), improved durability, improved reliability, and improved thermal management. The higher line-to-line voltages of the MHDV BEVs will likely require an improved class of insulation.

Other characteristics need further research to determine MHDV BEV needs:

- ▶ What will the impact of low- (<5K rpm), medium- (<12K rpm), and high-speed (>12K rpm) machines be in MHDV BEVs?
- ▶ Will they require a higher number of phases?
- ▶ How do multiple powered axles in MHDVs create opportunities for motor topology and traction architecture optimization?
- ▶ Will Induction motors or reluctance motors perform better in this application?
- ▶ Will mixed motor topologies present unique opportunities and functions for the traction system?

- ▶ Can MHDV BEV engines tolerate more torque ripple and/or vibration?
- ▶ How does the motor and traction drive architecture get optimized and what are the value propositions in MHDV applications?
- ▶ Are there pathways to scale specific motor topologies across a number of different MHDV applications?

## Power Devices

---

Silicon carbide (SiC) devices have higher voltage capability and efficiency than their conventional Si counterparts and are already replacing Si devices in passenger vehicle electric drives. SiC devices are also of interest for commercial vehicles. For 1200 V DC link voltage, 1700 V or higher-voltage-class devices will be required. These devices are currently not available in the quantities needed for commercial vehicle electrification. Furthermore, these devices are of interest in part because of their reliability and durability, but these characteristics have yet to be proven. Shared reliability data from standard third-party testing is needed to confirm device reliability. Characterization of the newest devices would also help suppliers and OEMs decide what devices to use. It is also important to identify failure mechanisms including extrinsic failure.

Most of the single-die SiC devices have lower current-carrying capabilities. Higher-current-carrying, single-die SiC devices are needed. New power device materials, such as ultra-wide bandgap devices, would also be of interest for achieving better-performing traction inverters.

## Power Modules

---

Availability of high-current-power modules (includes the base plate, the substrate, wire bonds, and power semiconductor chips) for commercial vehicles is a concern, as are the higher cost and lower reliability. Research is needed either to increase the die size for higher current-carrying capability or to enable more devices being paralleled with reduced parasitic inductance. Integrated thermal management or cooling channels could keep the die temperatures equal to further improve reliability of the power modules. In addition, power module reliability will have to be investigated. As mentioned earlier, higher DC link voltages will need devices with higher voltage power ratings. Another alternative is to use multilevel inverters, which will need different power modules from the standard commercial ones.

## DC Link Capacitors

---

In electric vehicle applications, DC link capacitors help offset the effects of inductance in inverters, motor controllers, and battery systems. Typically, film capacitors are used, but U.S. DRIVE is researching the possibility of using lead–lanthanum–zirconium–titanate (PLZT) capacitors, which are much smaller. Since the voltages are different, there is a need for compatible high-voltage capacitors or lower-voltage capacitors put in series.

Durability and reliability of these capacitors are also a concern. An important research area could be new dielectric materials that can result in higher-voltage capacitors that have safe failure mechanisms, are more reliable, and have the durability to last 1,000,000 miles. These capacitors also must be able to handle much higher ripple currents.

Integrated cooling channels and direct-cooled capacitors could be used for thermal management, increasing the reliability of these components. Optimized heat sinks and new coolants would be needed to remove the higher losses resulting from higher-power applications.

### Motor Insulation

---

Higher-voltage batteries will require higher-voltage-class insulation needed for electric motors. Higher rise and fall times of SiC switches could degrade insulation materials. New insulation materials will be needed for better reliability and longer durability.

### Magnets

---

Permanent magnet synchronous motors (PMSMs) need domestic magnets with a high-energy product that will not be demagnetized during operation.

### Conductor/Wiring

---

Increasing the thermal conductivity of wiring would help better cool the electric motor, increasing motors efficiency and lifetime. Increasing the electric conductivity would also increase efficiency and would also reduce the motor's size; a 100% increase in conductivity can reduce the size of the electric motor by 30% (Raminosoa and Aytug 2019).

# Strategy to Achieve Technical Targets: Approaches for Overcoming Barriers/Challenges

## Powertrain System Architecture

### High-Power-Computing-Based Modeling

---

Defining representative duty cycles for each of the 10 applications of interest is key to evaluating the benefits of electrified powertrains. Short duty cycles are typically used to represent how vehicles are utilized. They are convenient and provide an easy and rapid way to compare powertrains. However, they are limited in that they do not represent the variability that different customers may experience. With today's high-performance computing (HPC) capabilities, we can extend the evaluation of powertrain technologies to a wide variety of duty cycles and use cases to cover a broader range of customer usage. Real-world duty cycle data covering multiple vehicles over long periods of time can be used to assess the benefits of powertrain technologies.

Large-scale HPC modeling will also be used to identify the selection of power nodes that will allow OEMs to cover all or most of the market. High-volume production is a key driver to bring down the cost of new component introduction. Limiting the number of power nodes will help reduce development and production cost. HPC modeling will help identify the power nodes that can be designed to suit a wide range of applications.

### Vehicle Control Optimization

---

While BEV and conventional vehicles have been the focus to date, hybridization and net-zero carbon fuels have the potential to provide cost-effective solutions to greenhouse gas emissions. With two power sources to drive the vehicle, vehicle control is critical to properly managing power flow and offers opportunities to optimize power and energy ratings to minimize payback periods. Hybridization can leverage opportunities for integrated micro-electrification of truck functions such as start–stop operation, idle reduction, waste heat recovery, accessory electrification, and engine transient load management; but detailed vehicle control strategies are required to ensure these functions operate efficiently.

## Electrical Energy Storage

### High-Power-Computing-Based Collection of Data, Modeling

---

The Battery Working Group relies on an HPC-based collaboration between Argonne, Idaho National Laboratory, and the National Renewable Energy Laboratory to understand battery requirements for vehicles across the full range of truck powertrain architectures, vocations, and drive cycles (National Renewable Energy Laboratory n.d.a; n.d.c). A central focus of this effort is robust data capture and data analytics. The modeling effort takes in real-world drive cycle data, chosen to represent a large fraction of real-world scenarios for a given truck vocation. These drive cycle data are incorporated into a model system that uses Autonomie to estimate LCOD. The individual component (battery) technical requirements are extracted from model outputs, and battery targets are finalized through the consensus of the working group. Successful model development enables the rapid assessment of other truck classes and vocations.

The model was developed and implemented for Class 8 line-haul tractors, which were chosen for two reasons: Class 8 long haul and regional haul tractors present particularly challenging battery requirements, and these vehicles represent a significant portion of commercial vehicle fuel consumption. The Argonne team modeled Class 6 box trucks and Class 4 step vans next, as these particular vocations comprise a significant number of medium-duty trucks on the road. However, all 10 of the highlighted vocations will eventually need to be modeled, as since they each have unique drive cycle requirements.

## Battery Packaging, System Architecture, and Integration

---

The mode of battery incorporation is integral to allowances for maximum battery pack mass and volume. Battery electric trucks may be most rapidly commercialized by retrofitting conventional truck chassis; however, this may place certain less-than-optimal restrictions on the battery packs and create challenges with regard to packaging and energy density. The eventual introduction of purpose-built chassis could lessen restrictions on battery weight and volume as the battery packs could, for example, be incorporated so as to be integral with the chassis structure, thereby creating a more integrated design.

## Applied Battery Materials Research and Development

---

Meeting the more stringent lifetime and energy density demands of MHDVs will require advances in battery materials. Many of these areas of applied battery R&D are incorporated in the VTO battery portfolio. This work can be grouped into three general battery chemistries: enhanced lithium-ion, next-generation lithium-ion, and beyond lithium-ion.

### *Enhanced Lithium-Ion*

Work in this area focuses on decreasing the use of critical materials, such as cobalt, and reducing costs by developing low-cost and scalable recycling procedures and enhanced electrode processing. It is expected that lithium-ion will be suitable for many medium- and heavy-duty truck applications. Fast charge capability will likely be vital for some applications, and the suitability of lithium-ion batteries to endure cycling at charge rates up to 6C is being addressed by the eXtreme Fast Charge Cell Evaluation of Lithium-ion Batteries (XCEL) project. This effort focuses on mechanistic understanding and mitigation of modes of battery degradation and loss in electrochemical performance when fast charging, including Li plating, particle cracking, and rapid temperature rise.

Advanced liquid electrolytes that utilize stable additives can allow for formation of stable solid–electrolyte interface (SEI) surfaces on both the anode and cathode during cycling under more extreme cycling conditions, including higher voltage, lower-temperature operation, and extreme fast charging.

Truck vocations demanding increased range and hauling capacity and those prioritizing energy density will likely require next-generation materials, such as Si anodes or even Li-metal battery chemistry.

Recycling could bring cost reduction in enhanced lithium-ion batteries. Two DOE-funded organizations are currently addressing battery recycling with a particular focus on rare or high-purity components. Several USABC projects are focused primarily on recovering transition metals from nickel–manganese–cobalt oxide (NMC) cathodes, and the ReCell Center is a national laboratory-led initiative taking a closed-loop approach to recovering valuable battery materials.

### *Next-Generation Lithium-Ion*

This work explores alloy anodes that are normally silicon-based and/or high-voltage and high-energy cathodes. These cells promise 20%–40% higher energy density than today’s cells and thus much lower cost. Cells using alloy anodes appear to provide inherently better fast charge performance. For advanced Si/Si-C composite anodes, stable SEIs, achieved in part by controlling purity and electrode surfaces, are essential to increasing battery lifetime. USABC includes several projects to boost Si content in batteries of commercially relevant size, while a national laboratory-led effort, the SEISta (SEI Stabilization) consortium, and several FOA projects target anodes with much higher Si content (>40 wt%) with 10-year calendar lives.

### *Beyond Li-Ion*

Li-metal anodes are considered the highest-energy and lowest-cost cell design possible. They could increase the gravimetric energy density significantly compared to current graphite anodes. Li-metal anodes will require surface modification/passivation and processes to produce thin, controlled layers. Finding materials solutions to make Li anode batteries more durable is a key pillar of the Battery500 Consortium approach to increasing energy density and could have significant impacts on future MHDV roadmaps.

Several projects in the Battery Materials Research portfolio focus on solid state cells that promise greatly enhanced abuse tolerance, as these cells do not contain the flammable liquid electrolyte present in today’s cells. Solid state electrolytes could also facilitate record energy densities through Li-metal anodes and silicon-based cathodes. Safety and high energy density are very desirable properties for many truck applications.

## Electrical Infrastructure

The roll-out of public charging infrastructure has so far focused mostly on serving electric LDVs. This early infrastructure deployment may serve as a guide for electrification of MHDVs. However, MHDVs require batteries with very high capacity to meet their needs, which include heavy-duty work cycles and long-range operations and, thus, high-power charging. Today, most high-power chargers are designed for use as en route charging for light duty fleet. These units are capable of depot and travel center charging of MHDVs at kW-scale power but not capable of MW-scale.

Depots, travel centers, and en route locations all lack—and will eventually require—the infrastructure to charge MHDVs. Depot charging will likely be the first adopters because an entire fleet can be charged at one location. Those fleets that return home each night to the same location will benefit from the convenience of depot low-power charging. Chargers of 1 MW and higher will be required to give MHDVs quick charging (low dwell time) at both travel centers and en route locations. Long-term planning for this megawatt-level charging infrastructure must begin now to avoid negative impacts to the electrical grid in the future. Significant investment will be needed for grid reinforcement, modernization, storage, and integration with the new high-power charging operations (International Energy Agency 2021).

## Electrification Components

The Electrification Components Working Group (ECWG) focuses on the systems requiring electric power conversion, starting with traction motors and inverters, which form the traction drive for BEVs. Some HEVs also include a boost converter, especially for lower-battery voltages, to increase the DC link voltage at times to improve the efficiency of the

drive. The high-voltage to low-voltage DC-to-DC converter is needed to distribute the power from the battery to the auxiliary systems and electrified accessories, which are also a part of the focus area. Because Class 8 vehicles will need high charging power levels, onboard chargers are not expected for Class 8 vehicles. However, there could be use cases for onboard chargers in Class 6 vehicles. Fuel-cell-powered vehicles will have these components and might include a fuel cell DC-to-DC converter or a battery DC-to-DC converter, depending on the architecture use, to regulate the DC link voltage.

The off-board DC chargers are, in general, within the scope of the Charging and Infrastructure Working Group; however, since using these chargers would necessitate multiple power conversion stages to achieve the DC voltages needed for the vehicles, the associated component research is also within the ECWG scope.

The electrification components within power electronics include power devices, power modules, DC link capacitors, thermal management, inductors, conductors (bus bars, cable, connectors), gate driver controllers, and sensors. On the motor side, the components of interest are conductors (wiring), insulators, magnetic steels, and magnets.

To meet the 2030 targets, the ECWG has prioritized the areas to improve as follows (in order): cost, reliability, durability, efficiency, volume, and weight.

## Comparison to U.S. DRIVE

For both U.S. DRIVE and 21CTP, cost is the top priority. The second priority for U.S. DRIVE is volume, whereas reliability and durability are of higher importance for MHDVs (and thus are of higher priority for 21CTP). Reliability and durability are important for both partnerships, but the targets are different. For U.S. DRIVE, the durability target is set for a lifetime of 300,000 miles. On the other hand, the target is 550,000 miles for a Class 6 vehicle and 1,000,000 miles for a Class 8 tractor. As noted above in Medium- and Heavy-Duty vs. Light-Duty Vehicles, scaling up components for passenger vehicles for use in MHDVs will not help developers and manufacturers meet sector targets.

Another difference between the two partnerships is the DC link voltage. Today, passenger vehicles on the road typically use batteries with voltages between 400 V and 800 V. The trend is to go to 800 V to achieve faster, more efficient charging speeds. Higher voltage translates into higher electric drive efficiencies since the current levels will be lower for the same traction power. For the same reasons, commercial vehicles today have DC voltages of 700 V, with a possibility of escalating to 1200 V soon. Charging standards for commercial vehicles will impact the battery voltage in commercial vehicles, as it did in passenger vehicles. Adding a DC-to-DC converter to reduce the voltage of the charger would add additional losses and cost the system. If the battery voltage is selected within the standard range, these losses and costs would be eliminated.

On the electric motor side, passenger vehicles on the road typically use PMSMs with rare earth magnets, most of which are imported. To reduce dependence on foreign magnets, U.S. DRIVE focuses on motors with no heavy rare earth materials; this would also be a focus area for 21CTP. Some electric motors with no magnets are inappropriate for passenger vehicles because of the torque pulsations, which cause vibrations that could make passengers uncomfortable. In passenger vehicles, the electric motor is very close to the driver and the passengers. Commercial vehicles, especially Class 8 vehicles, have a greater distance between motor and driver, so non-permanent magnet-based motors (such as switched reluctance motors and synchronous reluctance motors) might be viable options.

## Bibliography

- Bennett, Jesse, Partha Mishra, Eric Miller, Brennan Borlaug, Andrew Meintz, and Alicia Birky. n.d. “Estimating the Breakeven Cost of Delivered Electricity to Charge Class 8 Electric Vehicles.” National Renewable Energy Laboratory.
- Bennett, Jesse, Cabell Hodge, Chuck Kurnik, Kosol Kiatreungwattana, Lauren Lynch, and Jimmy Salasovich. 2019. *Electric Vehicle Supply Equipment Tiger Team Site Assessment Findings from Army Facilities*. Golden, CO: National Renewable Energy Laboratory. NREL/TP-5400-74538. <https://www.nrel.gov/docs/fy20osti/74538.pdf>
- Borlaug, B., Muratori, M., Gilleran, M. et al. 2021. “Heavy-duty truck electrification and the impacts of depot charging on electricity distribution systems.” *Nat Energy* 6, 673–682. <https://doi.org/10.1038/s41560-021-00855-0>.
- Estimating the Breakeven Cost of Delivered Electricity to Charge Class 8 Electric Vehicles.” National Renewable Energy Laboratory. Draft report.
- Boyd, Steven. 2020. “Batteries and Electrification R&D.” *VTO Annual Merit Review Plenary*. [https://www.energy.gov/sites/prod/files/2020/08/f77/Boyd-2020\\_AMR\\_Plenary-Batteries\\_and\\_Electrification\\_Overview\\_0.pdf](https://www.energy.gov/sites/prod/files/2020/08/f77/Boyd-2020_AMR_Plenary-Batteries_and_Electrification_Overview_0.pdf).
- CARB. n.d. “Advanced Clean Trucks.” *California Air Resources Board*. Accessed December 2021. <https://ww2.arb.ca.gov/our-work/programs/advanced-clean-trucks>.
- CARB. 2021. “Heavy-Duty Omnibus Regulation.” *California Air Resources Board*. October 15. <https://ww2.arb.ca.gov/rulemaking/2020/hdomnibuslownox>.
- DOE. n.d. “The U.S. National Blueprint for Transportation Decarbonization: A Joint Strategy to Transform Transportation.” <https://www.energy.gov/eere/us-national-blueprint-transportation-decarbonization-joint-strategy-transform-transportation>.
- DOE VTO. 2021. Annual Merit Review Presentations. *energy.gov*. <https://www.energy.gov/eere/vehicles/annual-merit-review-presentations>.
- GNA. 2020. *The State of Sustainable Fleets*. National Academies of Sciences, Engineering, and Medicine 2020.
- Gohlke, David, et al. 2021. “Comprehensive Vehicle Total Cost of Ownership (TCO) Framework.” Argonne National Laboratory. Presentation given at the Vehicle Technologies Office 2021 Annual Merit Review, virtual event, June 22.
- Frost & Sullivan. 2013. *Strategic Outlook of North American Medium and Heavy Commercial Truck Powertrain Market*. Washington, DC: Frost & Sullivan.
- Harned, Alleyn. 2021. “Mid-Atlantic Electric School Bus Project (MEEP).” Presentation for the DOE VTO Annual Merit Review 2021. Project ID: DE-EE0008892 ti 120. [https://www.energy.gov/sites/default/files/2021-06/ti120\\_harned\\_2021\\_o\\_5-14\\_241pm\\_KF\\_ML.pdf](https://www.energy.gov/sites/default/files/2021-06/ti120_harned_2021_o_5-14_241pm_KF_ML.pdf).
- International Energy Agency. 2021. *Global EV Outlook 2021*. Paris. <https://www.iea.org/reports/global-ev-outlook-2021>.
- Klemick, H., E. Kopits, A. Wolverton, and K. Sargent. 2015. “Heavy-duty trucking and the energy efficiency paradox: Evidence from focus groups and interviews.” *Transportation Research Part A: Policy and Practice*: 154–166.
- Mai, Trieu, and et al. 2018. “Electrification Futures Study: Scenarios of Electric Technology Adoption and Power Consumption for the United States.” National Renewable Energy Laboratory, Golden, CO.

<https://www.nrel.gov/docs/fy18osti/71500.pdf>.

Muratori, Matteo, Eleftheria Kontou, and Joshua Eichman. 2019. "Electricity rates for electric vehicle direct current fast charging in the United States." *Renewable and Sustainable Energy Reviews* 113 (October).

<https://doi.org/10.1016/j.rser.2019.06.042>.

NACFE. n.d. "Electric Truck Education: Bootcamp Trainings." *Run on Less*. Accessed November 2021.

<https://runonless.com/bootcamp/>.

NACFE. 2022. *Run on Less: Electric Report*. <https://nacfe.org/wp-content/uploads/edd/2022/01/RoL-Electric-Report-FINAL.pdf>.

National Academies of Sciences, Engineering, and Medicine. 2020. *Guidebook for Deploying Zero-Emission Transit Buses*. Washington, DC: The National Academies Press. <https://doi.org/10.17226/25842>.

National Academies of Sciences, Engineering, and Medicine. 2015. *Review of the 21st Century Truck Partnership, Third Report*. Washington D.C.: The National Academies Press.

National Energy Technology Laboratory. 2021. "U.S. Department of Energy Selects 12 Projects to Improve Fossil-Based Hydrogen Production, Transport, Storage and Utilization." Funding Opportunity Announcement. July 7.

<https://netl.doe.gov/node/10875>.

National Research Council. 2015. *Report on Light-Duty Vehicle Fuel Economy and Technology Costs*. Washington, DC: National Academies Press.

National Research Council. 2010. *Technologies and Approaches to Reducing the Fuel Consumption of Medium- and Heavy-Duty Vehicles*. Washington, DC: National Academies Press.

National Renewable Energy Laboratory. n.d.a "Fleet DNA Project Data." National Renewable Energy Laboratory (website). Accessed March 2022. [www.nrel.gov/fleetdna](http://www.nrel.gov/fleetdna).

National Renewable Energy Laboratory. n.d.b "Fleet DNA: Commercial Fleet Vehicle Operating Data." National Renewable Energy Laboratory (website). Accessed December 2021.

<https://www.nrel.gov/transportation/fleetest-fleet-dna.html>.

National Renewable Energy Laboratory. n.d.c "NREL DriveCAT – Chassis Dynamometer Drive Cycles." National Renewable Energy Laboratory (website). Accessed March 2022. [www.nrel.gov/transportation/drive-cycle-tool](http://www.nrel.gov/transportation/drive-cycle-tool).

Oak Ridge National Laboratory and National Renewable Energy Laboratory. 2019. *Medium- and Heavy-Duty Vehicle Electrification: An Assessment of Technology and Knowledge Gaps*. Prepared by Oak Ridge National Laboratory and National Renewable Energy Laboratory for the U.S. Department of Energy, Office of Energy Efficiency and Renewable Energy. <https://info.ornl.gov/sites/publications/Files/Pub136575.pdf>.

T. Raminosa and T. Aytug. 2019. "Impact of Ultra-Conducting Winding on the Power Density and Performance of Non-Heavy Rare Earth Traction Motors." 2019 IEEE International Electric Machines & Drives Conference (IEMDC): 2107–2114. doi: 10.1109/IEMDC.2019.8785295.

Torrey, W. Ford, and Dan Murray. 2016. "An Analysis of the Operational Costs of Trucking: 2016 Update." American Transportation Research Institute, Arlington, VA. <https://truckingresearch.org/wp-content/uploads/2016/10/ATRI-Operational-Costs-of-Trucking-2016-09-2016.pdf>.

U.S. Energy Information Administration. 2022. *Annual Energy Outlook 2022 with projections to 2050*. March.

[https://www.eia.gov/outlooks/aeo/pdf/AEO2022\\_Narrative.pdf](https://www.eia.gov/outlooks/aeo/pdf/AEO2022_Narrative.pdf).

U.S. Energy Information Administration. 2021. "Petroleum & Other Liquids." *U.S. Energy Information Administration: Independent Statistics & Analysis*. December 13.

<https://www.eia.gov/dnav/pet/hist/LeafHandler.ashx?n=PET&s=EMD EPD2D PTE NUS DPG&f=W>.

Vehicle Systems and Mobility Group. n.d. "Autonomie: State-of-the-art Vehicle Energy Consumption, Performance and Cost System Simulation." <https://vms.es.anl.gov/tools/autonomie/>.

## Appendix A – Levelized Cost of Driving (LCOD) Analysis

The figures below use the following abbreviations/acronyms:

- ▶ CONV – Conventional
- ▶ ISG – Integrated starter generator (or mild hybrid)
- ▶ HEV – Hybrid electric vehicle (not a plug-in)
- ▶ EREV – Extended-range electric vehicle
- ▶ BEV – Battery electric vehicle

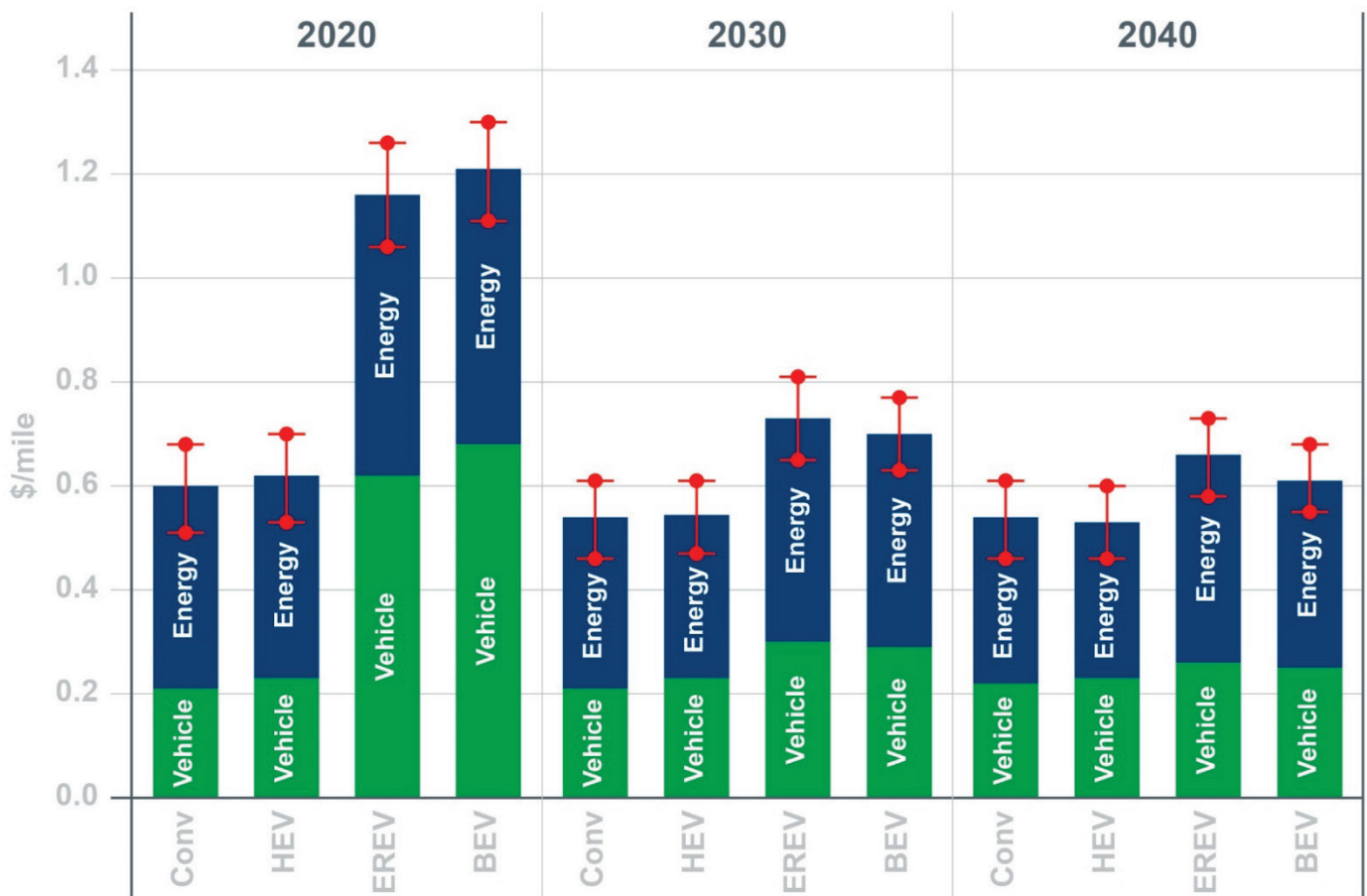

Figure 15. LCOD values for Class 8 long haul tractor

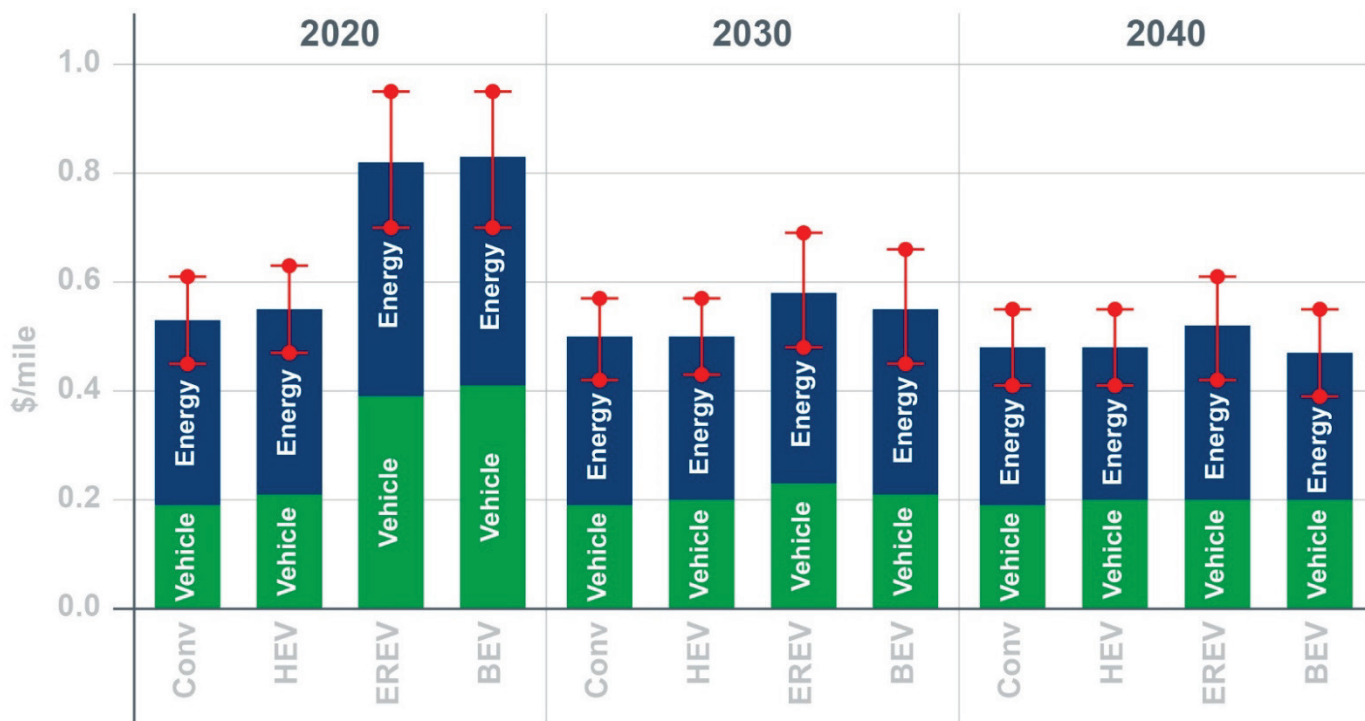

Figure 16. LCOD values for Class 8 regional haul tractor



Figure 17. LCOD values for Class 6 box truck



Figure 18. LCOD values for Class 4 step van

## Appendix B – 21CTP Electrification Technologies Team Roadmap 2.0

The following items have been identified as subjects to be included in the next ETST Roadmap.

**Fuel Cell Electric Vehicles:** The current ETST Roadmap focuses only on battery technology as the energy source for an electric vehicle. The next ETST Roadmap should include fuel cell electric vehicles (FCEVs).

**Additional Powertrain and Fuel Options:** The current roadmap has considered five unique powertrains: conventional diesel, integrated starter generator, hybrid electric vehicle, extended-range electric vehicle, and battery electric vehicle. In addition to FCEVs, the next ETST Roadmap should include hydrogen internal combustion engines and other promising powertrains and fuels.

**Electrified Roadways / Dynamic Wireless Power Transfer / Overhead Catenary Wires:** The current roadmap focuses on conventional plug-in charging systems. The next roadmap should also consider other promising forms of charging.

**Additional Sensitivity Analysis:** We would like to know which elements within the model provide the most significant impact on the levelized cost of driving (LCOD). For example, it would be helpful to estimate the impact on the LCOD of a battery cost reduction of 10%. Other examples include the costs of electricity and diesel fuel.

**Analysis of Additional Vocations:** The current roadmap focuses on the top four primary vocations within the medium- and heavy-duty vehicle (MHDV) market, as identified in the chart below. We would like to include additional vocations and drive cycles— perhaps up to the top 10 vocations—in the next roadmap. Towing could also be included as appropriate for each vocation—and specifically for the Class 3 Pickup.

Group	Vocation	Body Style	Timeframe (Production / Model Year)
A. Significant Fuel Use Reduction	1. Long-Haul 2. Local Delivery	1. CL 8 Sleeper 2. CL 8 Day Cab	<ul style="list-style-type: none"> <li>• 2020 - baseline</li> <li>• 2025</li> <li>• 2030</li> </ul>
B. Early Adopters & Important Vocations to consider for Alternative Fuels	3. Pick-up & Delivery 4. Pick-up & Delivery 5. Transit (City) 6. Service Vehicles (Significant Engine Off PTO Usage) 7. General Purpose 8. Heavy Vocational 9. Heavy Vocational 10. School Bus	3. CL 6 Box Truck 4. CL 4 Step Van 5. CL 8 Bus 6. CL 4 or 5 Service  7. CL 3 Pickup 8. CL 8 Dump 9. CL 8 Refuse 10. CL 6/7 School Bus	<ul style="list-style-type: none"> <li>• 2035</li> <li>• Beyond 2035 - long term</li> </ul>

Figure 19. Recommended Vocational Segments

**Temperature Extremes – Both Summer and Winter:** We would like to consider the impacts of extreme temperatures on battery size and performance characteristics, determine whether we model these extremes relative to battery life, and consider the energy draw of heating and air conditioning and the associated impacts on battery charge and range. FCEVs also need to be analyzed at extreme temperatures, as they can be difficult to cool in hot temperatures.

**Common Definitions, Assumptions, and Repository within All 21CTP Tech Teams:** The current roadmaps for each of the 21CTP tech teams use similar assumptions for most input to their modeling. However, there are a few cases in which definitions or assumptions can differ. For example, in the ETST Roadmap, a regional tractor drives up to 250 miles per day; whereas in the FOETST Roadmap, a regional tractor drives up to 150 miles per day. A common repository is also required for all these assumptions.

**2050 Modeling / Future Cost Targets for the Motor and Inverter:** Some ETST members have stated that the current 2040 target costs for the motor and inverter are not aggressive enough. We would like the Electrified Components Working Group to re-address these cost targets in the next roadmap. The current roadmap stops in the year 2040. The next ETST Roadmap should model and forecast out to the year 2050, similar to the recently published DOE National Blueprint for Transportation Decarbonization (DOE n.d.). The manufacturing and re-cycle carbon impacts should also be considered; cradle-to-grave analysis should be conducted to better understand the total impacts of transportation.

**Additional Crosstalk with other Tech Teams and U.S. DRIVE:** Wherever possible, the next ETST Roadmap should share ideas, data, and assumptions with the other 21CTP tech teams and the U.S. DRIVE tech teams. The new joint tech teams are a good first step toward facilitating this crosstalk.

**Investigate use of LDV components for the MHDVs:** The LDV market is significantly larger than the MHDV market. This extremely large market facilitates large R&D budgets – much larger than can be expected from the MHDV market. Even though the MHDV market has many unique characteristics for performance and life, there will be opportunity for the MHDV market to benefit from some technology developed through LDV market R&D. Example: Deep Dive into Optimal Battery Chemistries by Vocation.

**Hybrid Powertrain Components:** The next roadmap should examine whether the electrical components for hybrids can be optimized. (The Internal Combustion Engine Technical Sector Team (ICETST) is working on the engine optimization for hybrids.)

**Megawatt Charging:** – What should be in the roadmap and how does it impact the infrastructure – where and when is it required. What power levels? Potential impacts to other components? (Batteries?)

**Charging Infrastructure Implications to BEV's vs. Defining Operational Requirements by Vocation:** The current ETST Roadmap states that vehicle operational requirements are defined by vocation - as they are currently used with a conventional powertrain. The question is: Should we study the impact to a BEV (smaller or larger battery required) based on changes made to the charging infrastructure (shorter or longer distances between charging facilities)?

## Appendix C – Acronyms and Nomenclature

Acronym	Definition
21CTP	21st Century Truck Partnership
6C	(Charge rate of 6 full charges per hour – 10 minutes per charge)
AC	Alternating Current
BEV	Battery Electric Vehicle
C	Carbon
CARB	California Air Resources Board
Co	Cobalt
CONV	Conventional
DC	Direct Current
DOE	U.S. Department of Energy
DST	Dynamic Stress Test
ECWG	Electrification Components Working Group
EIA	U.S. Energy Information Administration
EREV	Extended Range Electric Vehicle
ETST	Electrification Technologies Sector Team
EUCAR	European Council for Automotive R&D
EVSE	Electric Vehicle Supply Equipment
FOA	Funding Opportunity Announcement
HEV	Hybrid Electric Vehicle
HPC	High-Performance Computing
ICE	Internal Combustion Engine
ISG	Integrated Starter Generator
K	Thousand(s)
kg	Kilogram(s)
kW	Kilowatt(s)
kWh	Kilowatt-Hour(s)

L	Liter(s)
LCOD	Levelized Cost of Driving
LDV	Light-Duty Vehicle
Li	Lithium
M	Million(s)
MHDV	Medium- and Heavy-Duty Vehicle
MW	Megawatt(s)
Ni	Nickel
Nm	Newton Meter(s)
NMC	Nickel–Manganese–Cobalt Oxide
NOx	Nitrogen Oxide
NREL	National Renewable Energy Laboratory
OEM	Original Equipment Manufacturer
ORNL	Oak Ridge National Laboratory
PHEV	Plug-in Hybrid Electric Vehicle
PLTZ	Lead–Lanthanum–Zirconium–Titanate
PMSM	Permanent Magnet Synchronous Motor
PSA	Powertrain Systems Architecture
R&D	Research and Development
RPE	Retail Price Equivalent
rpm	Revolutions per Minute
SAE	Society of Automotive Engineers
sec	Second
SEI	Solid–Electrolyte Interface
SEISta	SEI Stabilization (consortium)
Si	Silicon
SOC	State of Charge
TCO	Total Cost of Ownership

USABC	U.S. Advanced Battery Consortium
U.S. DRIVE	Driving Research and Innovation for Vehicle efficiency and Energy sustainability (the U.S. DRIVE Partnership)
V	Volt(s)
VTO	Vehicle Technologies Office
W	Watt(s)
WG	Working Group
Wh	Watt-Hour(s)
XCEL	eXtreme Fast Charge Cell Evaluation of Lithium-ion Batteries (project title)