



Durango, Colorado, Disposal and Processing Sites

An UMTRCA Title I site

This fact sheet provides information about the **Durango sites**. These sites are managed by the **U.S. Department of Energy Office of Legacy Management under Title I** of the **Uranium Mill Tailings Radiation Control Act of 1978**.

Canyon, located 3.5 miles southwest of Durango. DOE, in consultation with the state of Colorado and the U.S. Nuclear Regulatory Commission (NRC), finished the cleanups, and NRC accepted closure of the disposal site in 1996.

Site Information and History

The Durango processing site is the location of a former uranium mill in the city of Durango, Colorado. The former processing site consists of two separate areas: the mill tailings area and the raffinate ponds area. Both areas are located on the west bank of the Animas River and are immediately southwest of the intersection of U.S. highways 160 and 550. A narrow terrace above the Animas River connects the two areas.

In 1942, a vanadium mill was built on the site of an old lead smelter plant by the United States Vanadium Corporation (USV). In 1943, USV began reprocessing vanadium tailings for the recovery of uranium for sale to the Manhattan Project and operated the mill until 1946 when the mill was shut down. Beginning in 1949, the Vanadium Corporation of America operated the mill and sold uranium to the U.S. Atomic Energy Commission for national defense purposes until 1963, when it was shut down permanently. Approximately 1.2 million cubic yards of radioactive mill tailings, a predominantly sandy material, resulted from the milling operations.

From 1986 to 1991, the U.S. Department of Energy (DOE) removed mill tailings and other contaminated materials from the site and from vicinity properties (private and municipal properties or residences) where radium-226 or radon levels exceeded standards established by the U.S. Environmental Protection Agency (EPA). The contaminated materials, including approximately 122,000 cubic yards from vicinity properties, were stabilized in a disposal facility in Bodo

Long-term soils management is required at the former processing site where residual contaminated soils were left in place in two areas along the bank of the Animas River and in unreachable areas of windblown contamination on the adjacent slope of Smelter Mountain. DOE contoured and reseeded the former mill tailings and raffinate ponds areas with native grasses.

The state of Colorado transferred ownership of the former mill tailings area to the city of Durango, and the former raffinate ponds area to the Animas-La Plata Water Conservancy District.

Regulatory Setting

Congress passed the Uranium Mill Tailings Radiation Control Act (UMTRCA) in 1978 (Public Law 95-604) and DOE cleaned up 22 abandoned uranium mill sites and associated vicinity properties under the Uranium Mill Tailings Remedial Action (UMTRA) Project. Cleanup standards were promulgated by the EPA in Title 40 *Code of Federal Regulations* (CFR), Part 192, Subpart B.

UMTRCA authorized DOE to partner with affected states to conduct an assessment and initiate a remedial action. The state of Colorado participated in the nine UMTRCA Title I cleanups in the state of Colorado.

The radioactive contaminated materials were encapsulated in a disposal facility meeting requirements established in 10 CFR 40.27.

Former Raffinate Ponds Area

Former Mill Tailings Area

View of Durango, CO, Remediated Processing Site (1991).

Processing Site

DOE designed separate groundwater compliance strategies for the mill tailings area and the raffinate ponds area to better address the constituents of concern.

Mill Tailings Area

Alluvial groundwater beneath the mill tailings area and surface water along the Animas River is currently monitored for cadmium, molybdenum, uranium, and selenium.

The compliance strategy for the mill tailings area is natural flushing (i.e., natural groundwater movement and geochemical processes that decrease contaminant concentrations through time) in conjunction with institutional controls and continued monitoring. Groundwater modeling suggests analyte concentrations, except selenium, will decrease to levels below their respective standards within 100 years, the maximum time allowed under 40 CFR 192. Evaluation of sample results from background wells has shown that elevated selenium concentrations are due to naturally occurring sources and are not related to uranium ore processing.

Raffinate Ponds Area

Groundwater flow at the raffinate ponds area is primarily through joints, faults, and fractures in bedrock formations in the area. Uranium and selenium are monitored in groundwater and surface water. Elevated selenium concentrations at the raffinate ponds area are not mill related and derive from natural geologic sources in the area.

The groundwater compliance strategy is no further remediation in conjunction with application of supplemental standards, institutional controls, and continued monitoring. Supplemental standards for groundwater are quality standards that may be applied when at least one of eight criteria in 40 CFR 192.21 is satisfied.

The criterion that applies to groundwater at the raffinate ponds area is that of “limited use.” In other words, the groundwater is considered to have limited use and is not a current or potential source of drinking water because of “widespread, ambient contamination that cannot be cleaned up using treatment methods reasonably employed in public water systems.”

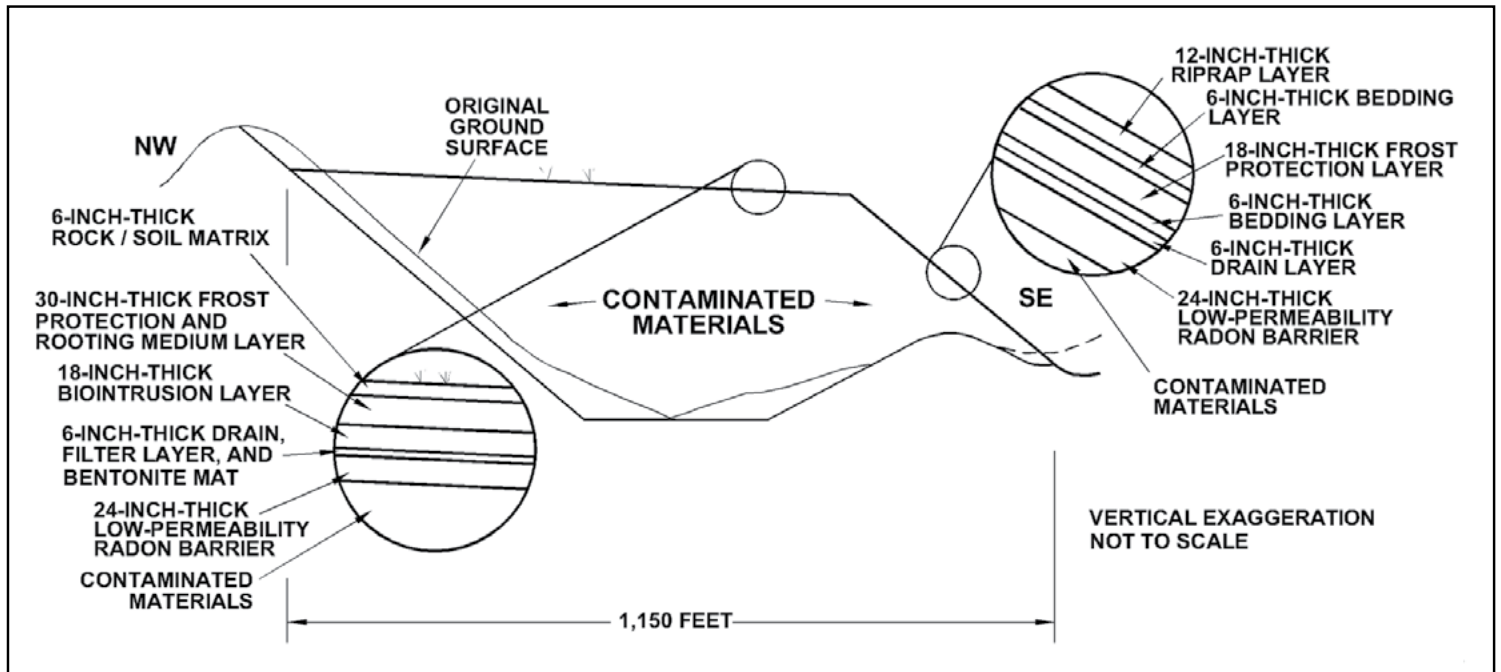

Northwest-Southeast Cross Section of the Durango Disposal Cell.

Institutional Controls 🏢

Institutional controls are safeguards that protect human health and the environment and typically depend on some legal order, such as zoning ordinances and laws, to ensure protection is effective. Institutional controls at the Durango processing site restrict access and prohibit (without state of Colorado and DOE approval): drilling wells, exposing groundwater to the surface, using groundwater for any purpose, and unmanaged soil disturbances (where contaminated soils were left in place). Institutional controls will remain in place in perpetuity at the mill tailings area and raffinate ponds area.

Disposal Site 🏠

The disposal site is located near the north edge of the San Juan Basin, above the west end of Bodo Canyon. The uppermost aquifer beneath the site is in the Cliff House Sandstone of the Mesaverde Group. Groundwater in this aquifer is generally not suitable for domestic use because of relatively high levels of dissolved solids and poor water quality.

The disposal cell contains about 2.5 million cubic yards of contaminated materials, including tailings, building debris from demolished mill structures, windblown contamination, and vicinity properties. The total activity of the contaminated materials within the cell is estimated to be 1,400 curies of radium-226. Eighty-two warning signs define the site boundary.

The disposal facility occupies about 42 acres of a 120-acre disposal site that was transferred from the state of Colorado to DOE.

Disposal Cell Design

The Durango disposal cell is irregularly shaped and measures approximately 2,400 feet on its long axis by 1,300 feet across. The cell cover is a multicomponent system designed to encapsulate and isolate the contaminated materials.

The cover consists of: (1) a low-permeability radon barrier (first layer placed over compacted tailings), (2) a sand filter/drainage layer and a bentonite mat, (3) a layer of rock to prevent biointrusion, (4) a frost-protection/rooting-medium layer, and (5) a rock/soil matrix layer on the top and rock (riprap) on the side slopes to protect against wind and water erosion. The top of the disposal cell is planted with native grasses. Riprap is keyed into bedrock around the base of the cell to prevent erosion at the cell boundary.

The cell cover design promotes rapid precipitation runoff mitigating water infiltration. Runoff from the top slope of the cell flows to a surrounding rock apron that carries water away. Native vegetation has been re-established in disturbed areas at the site.

Legacy Management Activities 🧑‍🔬

The DOE Office of Legacy Management (LM) is responsible for monitoring groundwater compliance at the former Durango processing site. LM will also monitor institutional controls effectiveness and natural flushing progress.

LM manages the disposal site according to a site-specific long-term surveillance plan. Under provisions of this plan, LM conducts annual inspections of the site to evaluate surface feature conditions, monitors engineering controls, performs site maintenance as necessary, and monitors



Durango mill during active operations (date unknown). The smokestack for the old lead smelter is to the left, with the large tailings pile and conveyances across the center.



After the Department of Energy (DOE) completed surface cleanup, the city of Durango transitioned the former Durango, Colorado, uranium processing site into a public park and recreation area. As a dog-friendly park, the LM site manager's dog, Drake, is able to join site inspections.

groundwater to verify the continued integrity of the disposal cell. LM makes environmental monitoring data publicly accessible at: <https://gems.lm.doe.gov/#site=DUD> and <https://gems.lm.doe.gov/#site=DUP>.

In accordance with 40 CFR 192.02(a), the disposal cell is designed to be effective for 1,000 years, to the extent reasonably achievable, and, in any case, for at least 200 years. However, the DOE's general license has no expiration date, and LM's responsibility for the safety and integrity of the Durango disposal site will last indefinitely.



CONTACT INFORMATION

**IN CASE OF AN EMERGENCY AT THE SITE,
CONTACT 911**

**LM TOLL-FREE EMERGENCY HOTLINE:
(877) 695-5322**

Site-specific documents related to the **Durango, Colorado, Disposal and Processing Sites** are available on the LM website at www.energy.gov/lm/durango-colorado-disposal-and-processing-sites

For more information about LM activities at the **Durango, Colorado, Disposal and Processing Sites**, contact:

**U.S. Department of Energy
Office of Legacy Management
2597 Legacy Way
Grand Junction, CO 81503**

Email:
public.affairs@lm.doe.gov

DOE Office of Legacy Management
(970) 248-6070



www.energy.gov/lm



www.facebook.com/OfficeofLegacyManagement



www.linkedin.com/showcase/office-of-legacy-management