

Zero Energy Building Highlight:

Houston Advanced Research Center



JANUARY
2022

FOREWORD

The EERE Building Technologies Office (BTO) within the U.S. Department of Energy's Office of Energy Efficiency and Renewable Energy asked teams from three national laboratories to explore the specific technologies, systems, and approaches used to attain zero energy status in three commercial buildings located in Pittsburgh, Houston, and Atlanta. This case study examines the Houston Advanced Research Center constructed near Houston, Texas.

ACKNOWLEDGEMENTS

We extend our sincere thanks to HARC Vice President Mustapha Beydoun, Ph.D., and Senior Research Scientist Carlos Gamarra, PE, Ph.D., for their willingness to share data and resources and for their responsiveness to our many requests for information, interviews, and data points. We greatly appreciate all their help and support for this report.

Disclaimer

This work was prepared as an account of work sponsored by an agency of the United States Government. Neither the United States Government nor any agency thereof, nor any of their employees, nor any of their contractors, subcontractors, or their employees, makes any warranty, express or implied, or assumes any legal liability or responsibility for the accuracy, completeness, or any third party's use or the results of such use of any information, apparatus, product, or process disclosed, or represents that its use would not infringe privately owned rights. Reference herein to any specific commercial product, process, or service by trade name, trademark, manufacturer, or otherwise, does not necessarily constitute or imply its endorsement, recommendation, or favoring by the United States Government or any agency thereof or its contractors or subcontractors. The views and opinions of authors expressed herein do not necessarily state or reflect those of the United States Government or any agency thereof, its contractors or subcontractors.

Cover photo: HARC



ZERO ENERGY BUILDING HIGHLIGHT:

Houston Advanced Research Center

January 2022

Prepared for the
Building Technologies Office
Energy Efficiency and Renewable Energy
U.S. Department of Energy

Prepared by
Pacific Northwest National Laboratory

Kate Hickcox

Michael Myer

Tim Yoder, PE, CEM

Michael Tillou, PE

Contributors

U.S. Department of Energy

Cedar Blazek

Sarah Zaleski



ACRONYMS

DOE	U.S. Department of Energy
AEDG	Advanced Energy Design Guide
ANSI	American National Standards Institute
DC	Direct current
ERV	Energy recovery ventilator
EUI	Energy use intensity
Ft ²	Square feet
GFA	Gross floor area
GSHP	Ground-source heat pump
HVAC	Heating, ventilation, and air conditioning
ILFI	International Living Future Institute
kBtu	Thousand British thermal units
LED	Light-emitting diode
LEED	Leadership in Energy and Environmental Design
PV	Photovoltaic
SHGC	Solar heat gain coefficient
WWR	Window-to-wall ratio
ZEB	Zero Energy Building

CONTENTS

HARC Design	1
Building Envelope	3
Daylighting and Fenestration	4
Electric Lighting	6
Plug Loads.....	8
Ground-Source Heat Pumps	10
Mechanical Systems	11
Solar Energy	13
Keys to Success	14
Notes	16



HOUSTON ADVANCED RESEARCH CENTER

Certifications & Awards

- Zero Energy Certified, [ILFI](#), 2020
- [LEED](#) Certified (Platinum), 2017
- Development of Distinction, Urban Land Institute, Houston, 2019

Energy Use Intensity (EUI): 15 kBtu/ ft² /year

Total cost: \$6.5 million

Building footprint: 18,600 ft²

Construction: 2016-2017

Climate Zone: [2A](#) (hot and humid)

Zero Energy Buildings

Achieving zero energy is an ambitious yet increasingly achievable goal that is gaining momentum across markets to meet climate goals. A zero energy building (ZEB) is designed to operate ultra-efficiently and produce enough on-site renewable energy to equal or exceed the building's annual energy needs. More information about ZEBs is available on the U.S. Department of Energy [website](#) (DOE ZEBs).



Photo: HARC

HARC DESIGN

The Houston Advanced Research Center ([HARC](#)) is a nonprofit consortium providing independent, scientific research and analysis on energy, air, water, and climate issues. HARC built its certified zero energy building (ZEB) to house its headquarters and serve as a Living Laboratory. The building deploys a mix of traditional and custom technologies tailored to the site and climate. Construction costs (\$403/ft²) were above those of a typical Houston office building in 2019 (\$118 to \$164/ ft²), but annual energy costs are net negative. The building was designed and engineered by Gensler Architects, Walter P Moore engineers, and CMTA Consulting Engineers. Brookstone Construction Managers handled construction. This ZEB integrates the following systems:

- Highly efficient building envelope
- Strategic daylighting and fenestration
- Energy-efficient electric lighting
- Ground-source heat pumps
- Reduced plug loads
- Mechanical system
- Solar energy.



“To design a highly efficient building, you must know which systems are consuming energy, and you must work to reduce the impact from those systems. A zero energy building is not a product, it’s a process.”

CMTA Engineer

BUILDING ENVELOPE

The HARC building envelope is designed to provide excellent energy efficiency and moisture protection in Houston's hot and humid climate. Heat and moisture are common concerns, and thermal bridging should be avoided in any location that requires mechanical heating and cooling.

The R-value of HARC's wall and roof insulation and the U-value of its windows and doors (fenestration) exceed industry standards by 30%. The HARC envelope is enhanced by its low window-to-wall ratio (WWR), low air leakage rates, vented rainscreen, and continuous insulation to avoid thermal bridging (see Figure 1).

The envelope at HARC is substantially better than the minimum prescriptive requirements of ANSI/ASHRAE/IES Standard 90.1-2019, contributing to the building's overall energy efficiency (ASHRAE/IES 2019).

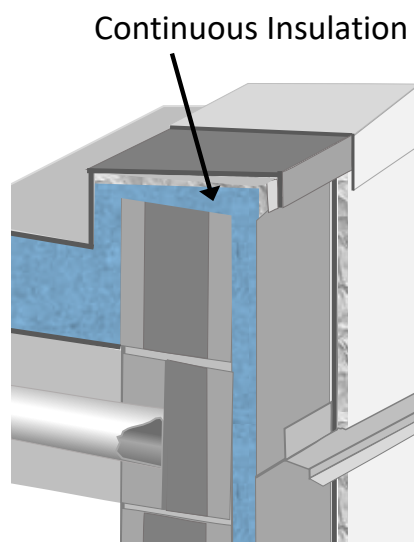

Figure 1. Continuous insulation can avoid thermal bridging. Source: Adapted from *Illustrated Guide: Achieving Airtight Buildings*, BC Housing.

Technical Highlights

Window-to-wall ratio (WWR): ANSI/ASHRAE/IES Standard 90.1-2019 prescribes a 40% WWR for buildings in the HARC climate zone, and the *Advanced Energy Design Guide* (AEDG) advises 30% or less. HARC has a WWR of 21%.

Roof: The building's 5" deep, continuous polyisocyanurate insulation on a metal roof deck provides R-32 insulation, 28% better than the ANSI/ASHRAE/IES Standard 90.1-2019 prescriptive requirement of R-25.

Exterior walls: The calculated U-value is 0.058 Btu/h-ft²-F, which is 30% better than the current prescriptive ANSI/ASHRAE/IES Standard 90.1-2019 of 0.084 Btu/h-ft²-F. The wall assembly exterior insulation R-value is sufficient to allow drying to the interior and does not contain materials susceptible to the risks of condensation.

Exterior cladding: A metal panel rain screen system with a top-vented, 1" air gap next to the exterior insulation helps lower direct solar gains, reducing interior cooling loads.

Thermal bridging: Bridging allows heat to bypass insulation layers, increasing heating and cooling loads. The HARC envelope minimizes thermal bridges by extending the continuous exterior wall insulation to the underside of the roof deck—with no structural or floor slab penetrations. Spray foam insulation at the wall-roof transitions forms a continuously *insulated assembly*.

Envelope: A well-designed, continuous air barrier reduces air leakage to help minimize heating/cooling loads. HARC's air leakage tested 75% better than the prescriptive ANSI/ASHRAE/IES Standard 90.1-2019.

DAYLIGHTING & FENESTRATION

Windows and doors or fenestrations (openings in the building envelope) provide building occupants a necessary connection to the outside world. Fenestration often increases occupant satisfaction and comfort while reducing electric lighting needs, but too much can add to cooling and heating loads. The goal is to balance heat gain and losses with the functional benefits of access to daylight and views.

The HARC building fenestration plan emphasizes effective daylighting and energy efficiency over symmetry. On the west façade, for example, the second floor has ample fenestration to light the many offices there, whereas the lower-level storage and mechanical rooms have little need for daylighting.

Within the building, collaboration spaces and corridors are placed along exterior walls, where large windows let in plenty of light (Figure 2). Private offices adjoining these spaces “borrow” daylight from the sunlit areas via large interior glass walls and doors.

Daylighting and fenestration strategies are necessarily climate specific. Location will inform the choice of glazing, window size and placement, and internal and external shading options.

In addition to an optimized site plan and architectural design, technical

Technical Highlights

- **Assembly U-Value.** The U-value of the overall building assembly (average U-value of envelope materials) is 0.315 Btu/h-ft²-F.
- **Glazing.** The 1” double-pane insulated glass provides a glazing U-value of 0.29 Btu/h-ft²-F. HARC balances a low SHGC of 0.27 with a high VT of 0.64 VT.
- **Framing Type.** HARC uses thermally broken aluminum with a U-Value of 0.92 Btu/h-ft²-F.

specifications for fenestration improve both building efficiency and occupant experience (e.g., visible transmission, solar heat gain coefficient, U-value).

High-performance glass with a low solar heat gain coefficient (SHGC) and high visible transmittance (see Figure 3) help reduce solar gain and cooling loads while enabling beneficial daylight and views of the outdoors. Fenestration in the HARC building was optimized to provide these benefits while minimizing negative thermal effects and increasing the overall energy efficiency of the building (Table 1).



Figure 2. Collaboration spaces and corridors are placed along exterior walls, where large windows let in plenty of light. Photo: Gensler Architects / Baldinger

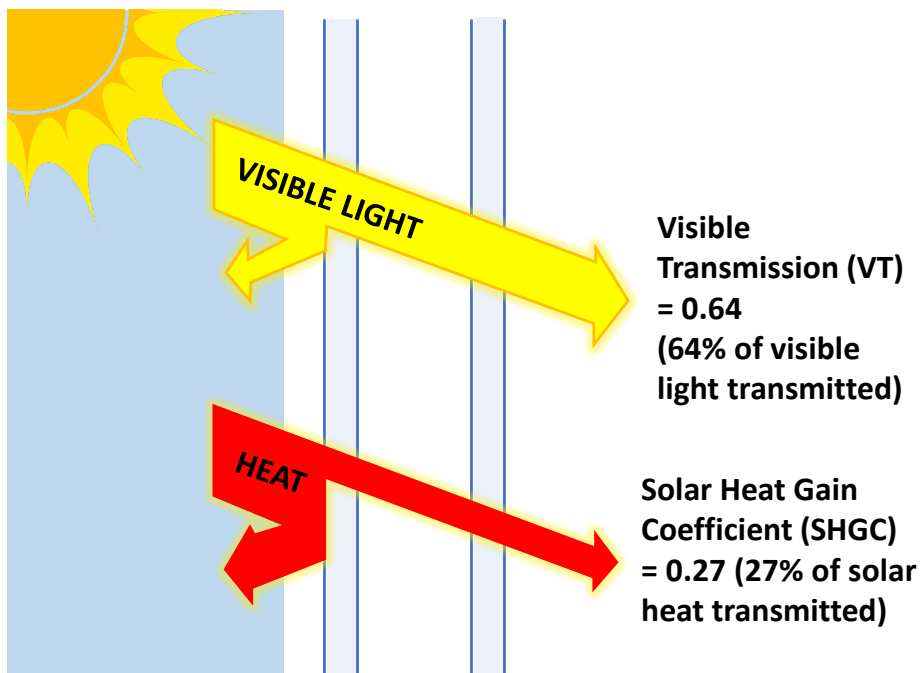

Figure 3. Technical window specifications are key to decreasing cooling and lighting costs, e.g., visible transmission, U-value, and solar heat gain coefficient.

ELECTRIC LIGHTING

HARC's energy-efficient electric lighting complements the daylighting strategy to keep building occupants safe and comfortable—whatever the weather or time of day (Figure 4). Efficiency is optimized by the choice of lighting technology, fixture design, and controls.

HARC's electric lighting represents 18% to 20% of the energy used in the building. The lighting energy use intensity (EUI) at HARC is between 3.65 and 4.15 kBtu/ft² (1.07–1.22 kWh/ft²), which is roughly 30% better (lower) than the 90.1-2019 standard.

Efficacy is only one aspect of lighting. Lighting equipment should produce sufficient illumination, control glare, and provide good color rendering. HARC opted for a suspended fixture design with direct/indirect linear lighting that allows the space to be well lit while minimizing glare. Electric lighting use can also be affected by building material finishes and interior color choices. HARC used light-colored finishes, which can make a space appear brighter and decrease the use of electric lighting.

The building design engineer observed that relatively few contractors are familiar with or experienced in managing advanced or networked lighting controls—increasing the potential for failure. For this reason, the HARC design team opted to use traditional, less complex lighting controls, including stand-alone

occupancy, vacancy, and daylight sensors.

Occupancy or vacancy sensors are a reliable way to ensure that electric lighting is turned off when not needed. At HARC, many of the fixtures are automatically dimmed in response to the available daylight. The sensitivity and time delay on many of these sensors were adjusted to suit occupant preferences and work habits.

Technical Highlights

- **Supplemental role.** Electric lighting at HARC is used to supplement daylighting only as needed.
- **Energy-efficient by design.** All light fixtures in the HARC office building use light-emitting diodes (LEDs) with an efficacy of 90+ lumens/W, which was advanced in 2017. The AEDG currently recommends lighting equipment with an efficacy greater than 125 lumens/W.
- **Sensors.** Standalone daylight and occupancy sensors effectively dim or turn off 95% of the lights according to need. Plans are underway to connect these sensors and controls to those of other building subsystems to optimize whole-building efficiency.
- **Share of building energy use.** HARC's electric lighting represents 18–20% of the energy used in the building.



Figure 4. Energy-efficient LED lighting amply illuminates HARC collaboration spaces for evening functions. Photo: Gensler Architects/Baldinger.

PLUG LOADS

As in most ZEB buildings, plug loads represent a sizeable portion of the total load at HARC. From 2020 to 2021, plug loads accounted for approximately half of all energy usage by the building. This outsized role of plug loads in ZEB buildings is due to the unusually small size of other loads in these buildings—owing to high levels of efficiency.

Of all the building systems used at HARC, plug loads have been the most challenging to minimize. After COVID restrictions drove nearly all staff to work from home in 2020, the building continued to use about 80% of the energy consumed in normal operations. Workstations had to stay on so that staff could log in remotely. In addition, the servers, which run without regard to occupancy, accounted for about 30% of the building's annual energy use (19% for computers plus 11% for heating, ventilation, and air cooling).

Plug load management is an ongoing challenge. As organizations grow over

time, they tend to add more staff and more plug-in devices (Figure 5), increasing energy use (Figure 6). HARC found that plug load energy increased by about 15% from 2018 through 2019.

In June 2019, HARC installed smart strips and a plug load monitoring platform on site. Using third-party vendor services and products, HARC now monitors plug loads in each office. This information helps the building staff track and target loads that may need to be better managed.

Over time, HARC's plug load management efforts successfully identified standby loads operating after hours. Measures to address these loads successfully reduced overall plug load energy by 15%, essentially flattening the curve. In addition to the smart strips and third-party monitoring software, HARC conducts ongoing audits of all on-site equipment.

Technical Highlights

- **Plug load monitoring platform.** HARC installed a commercial platform and portable meters to monitor, analyze, and report loads.
- **Reconfiguration.** The monitoring platform was reconfigured to focus entirely on variable rather than stable (essential) loads.
- **Continuous monitoring.** HARC's public and internal dashboards help the staff control and manage plug loads as the Center grows. Strong internal communications are critical.



A coffeemaker was removed after an audit discovered that it was not needed and used large amounts of energy. Photo: HARC

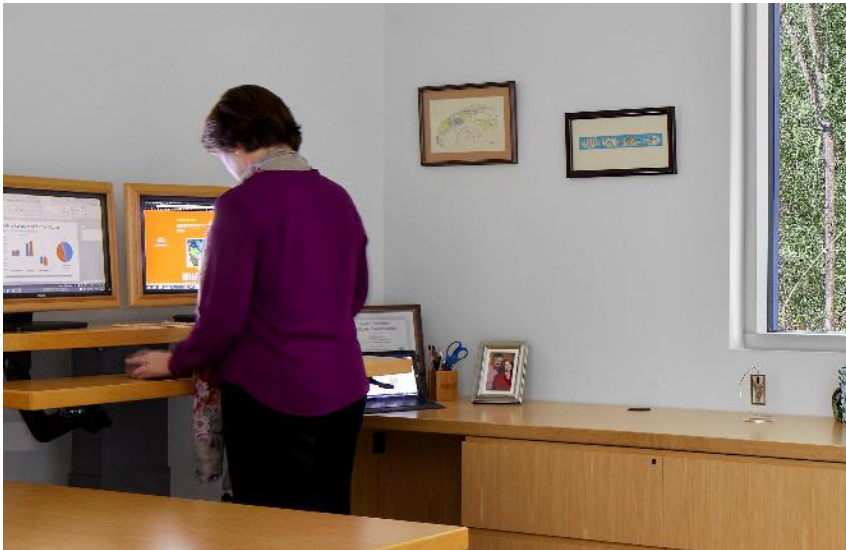

Figure 5. Plug loads require monitoring as they can rise incrementally with the addition of new equipment and staff. Photo: Baldinger

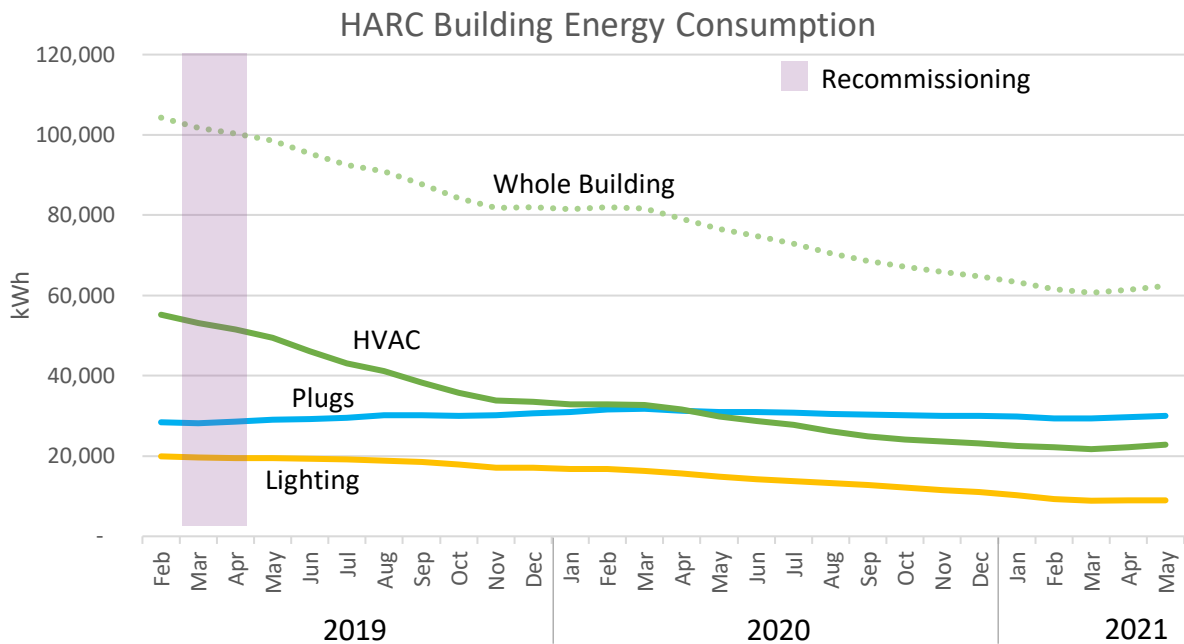

Figure 6. HARC monitoring shows tendency of plug loads to increase over time (blue line)—indicating the need for active review and management. Source: HARC.

GROUND-SOURCE HEAT PUMPS

The HARC building uses a field of 36 vertical wells as heat sources and sinks for 15 ground-source heat pumps (GSHPs). Each GSHP supports tailored space conditioning for a single room or small group of spaces.

The design engineers used a test well and building energy model to accurately size the well field and gauge its functionality over time. The well field's performance is closely tracked and validated by temperature sensors and flow meters installed across the system.

The coefficient of performance for GSHPs generally ranges between 4.8 and 6.1 (i.e., the ratio of heating or cooling output to the energy input to the system). In contrast, air-source heat



Figure 7. HARC's GSHPs use Houston's near-constant, below-ground temperature of about 72°F (Olgun 2015) to dispel or absorb heat. Photo: HARC

Technical Highlights

- **Distributed ground-source heat pumps:** 15 high-efficiency GSHPs use near-constant, below-ground temperatures to dispel or absorb heat.
- **Wells:** To minimize disturbance of the surrounding forest preserve, the 36 heat exchange wells were placed beneath the parking lot (Figure 7). The 300-ft. wells are 20 ft. apart within a row, with 25 ft. between rows.
- **Temperature sensors:** Sensors placed in a ground-exchange loop at the building entrance and in a monitoring well send data to the HARC building automation system for continuous monitoring. Sensors in the monitoring well are placed at 75 ft., 150 ft., and 225 ft. below grade. For ease of access, the monitoring well is below a parking island.

pumps typically have a coefficient of only about 3. The high efficiency of GSHPs plays a big role in the HARC building's zero energy status.

GSHP system design should always consider the thermal conductivity of the well field and the way in which ground temperatures change in response to a building's heating and cooling loads. In warm climates particularly, modeling the heat flow to and from the well field is key to sizing the well field for reliable performance.

MECHANICAL SYSTEM

Low energy use by HARC's heating, ventilation, and cooling (HVAC) system is a major factor in the building's zero energy status. The high-efficiency ground-source heat pumps (GSHPs) and energy recovery ventilator (ERV) work together with the high-performance building envelope to keep building temperatures comfortable without using significant amounts of energy.

HARC installed a fixed-plate ERV with enthalpy heat exchangers and no active conditioning (no heating or cooling coils) to provide all ventilation and exhaust air for the building. The unit uses the heat pump return temperature to further heat or cool the incoming ventilation air, depending on conditions (Figure 8).

The system underwent a real test during an extreme cold event in February 2021, when a power blackout affected large parts of Texas. While HARC lost power for nearly a day, the building envelope helped conserve energy, avoiding damage to the building and its equipment. The constant temperature of the GSHP field also allowed the heat pumps to operate at a high level of efficiency.

Energy efficiency undoubtably made the building more resilient. While the homes of HARC staff members suffered water damage due to burst or frozen

Technical Highlights

- **Distributed high-efficiency ground-source heat pumps:** All the GSHPs have variable-flow fans controlled by electronically commutated motors, and the larger ones (>2 tons cooling) have two-stage compressors, providing a good turndown ratio (maximum to minimum capacity). The GSHPs are configured vertically in dedicated mechanical spaces, enabling easy access for maintenance and acoustic mitigation.
- **Mechanical ventilation equipment:** Manufacturer efficiency ratings for the design airflow show 71% total heating and cooling effectiveness (sensible and latent [moisture]). After commissioning, the unit began operating at a sensible cooling effectiveness of 85%, about 13% above published values.
- **Air quality:** The design outdoor air temperatures were 96°F dry bulb and 78°F wet bulb (typical for a hot, humid climate). Houston's high dehumidification and cooling requirements make an ERV with high sensible and latent efficiencies particularly effective; colder or drier climate zones may not benefit as much.
- **HVAC:** HARC's modeled HVAC energy usage was 38.1 MWh. In 2019, the mechanical HVAC system achieved an EUI of 6.1 kBtu/ft² and consumed only 33.5 MWh of electricity, which was 41% of HARC's total electricity use that year. The building used less energy in 2020 due to COVID-19-related low occupancy.

pipes, the HARC building navigated the storm without any damage.

The efficient operation of HARC's mechanical ventilation equipment can be attributed to the building's thorough commissioning process— which is

critical for ZEBs. Despite the iterative design process and early engagement of contractors in construction planning, the HVAC system at HARC initially posed several issues upon occupancy. Now, after commissioning, the building operates with high efficiency.

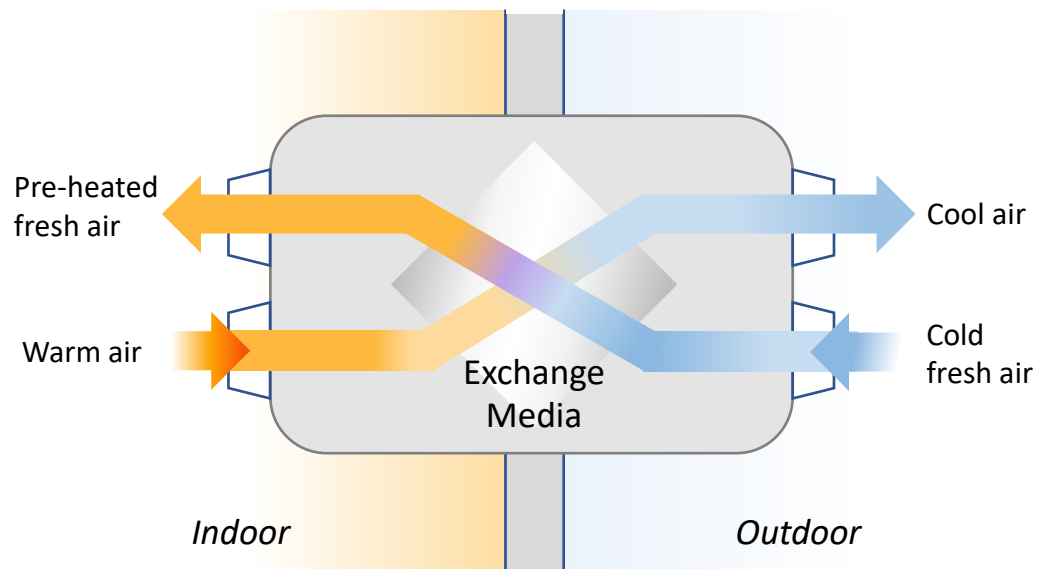

Figure 8. Energy recovery ventilators (ERVs) provide a cost-effective way to let a controlled amount of pre-conditioned fresh air into a building without driving up HVAC operating costs.

SOLAR ENERGY

Many ZEBs use photovoltaic (PV) panels to generate at least as much energy as the building consumes each year. The amount of PV required to balance a building's load varies by climate zone—and even within a zone. At HARC, the building's south-facing orientation and sloped roof are well suited for rooftop PV power generation. Not all renewable energy structures are appropriate for rooftop placement, and designers may need to explore other options, such as parking lots.

HARC's iterative design process allowed for a modular or incremental approach, facilitating enhancements and upgrades. Based on budgetary constraints, the PV panels at HARC were installed in two phases. The initial phase included 36 panels covering 800 ft² (4% of the gross floor area [GFA]). An additional 216 panels (4,000 ft²) were later added to the roof (26% of GFA [4,800 ft² of PV/18,600 ft² GFA]) to produce a total of 88 kW of DC power, more than covering the building's energy needs. This upgrade in solar production, together with energy efficiency improvements, took HARC from paying \$10,000 in annual electricity costs to receiving \$1,000 in annual credit from the utility company.

In both 2019 and 2020, the expanded PV system (Figure 9) generated more than 105,000 kWh, which is around 95% of the renewable power generation predicted by the PVWatts® calculator tool. This free, simple-to-use tool developed by the National Renewable

Technical Highlights

- **Solar panels:** 252 roof-mounted PV panels (30% of gross floor area) generate 88kW of DC power.
- **Cost:** The full PV system cost \$157,000 (\$8.46/ft² or roughly \$2 per Watt).
- **Inverters:** Five
- **Benefits:** The system saves HARC around \$11,000 in annual electricity costs and avoids over 85,000 pounds of carbon dioxide emissions each year.

Energy Laboratory (pvwatts.nrel.gov) requires no complex modeling or analysis.

According to AEDG guidance, PV area should be 22% of the GFA in this climate zone. By increasing the PV area to slightly exceed this recommended percentage of floor area while simultaneously reducing the EUI through operational improvements, HARC now typically generates more than 140% of its annual energy usage.



Figure 9. Rooftop solar panels as seen from the north side of the HARC office building. Photo: HARC

KEYS TO SUCCESS

Integrated ZEB planning and ongoing communications. In contrast to the traditional sequence, the HARC design process emphasized early engagement and ongoing communications among all key members of the design and construction teams. This highly integrated approach increased the time and cost of the design phase, but it paid off by reducing the time, effort, and money spent in later phases.

Integrated construction and operating cost analysis. HARC investment and financing decisions for the ZEB integrated capital expenditures and the long-term operating expenses. The HARC financial team was involved in design meetings and evaluated decisions throughout the process.

Iterative design process. Inviting the construction team into early design meetings virtually eliminated change orders, which can add to cost and delays. Design meetings involved the architect, engineers, construction manager, building financiers, and staff who would operate the building.

Commissioning. In the spring of 2019, HARC started a recommissioning process that effected a large drop in energy use for both electric lighting and HVAC. This recommissioning was initiated by the HARC on-site energy manager Carlos Gamarra, Ph.D., who is responsible for ongoing modifications to the systems. The original design, which used factory settings, was achieving 22 kBtu/ft²/yr, which was

within the target range. After optimization, the building achieved between 15 and 17 kBtu/ft²/yr. Even after extensive planning, commissioning is essential to make the appropriate tweaks to each system and make sure they work well together as components of the whole-building system.

With the right planning and research up front, ZEB status can be achieved without paying a cost penalty or sacrificing occupant satisfaction and comfort.

Continuous monitoring. The energy manager checks the building energy data each day and conducts a collective assessment of all technologies every six months. Monthly energy reports are distributed and assessed internally to identify any areas for system improvements.

Energy use varies slightly each year due to variations in building use, weather, and plug loads. Monitoring helps identify spikes or increased power usage. By monitoring the energy and occupancy data monthly, the energy manager identifies areas with low occupancy or usage and customizes the HVAC schedule. An internal campaign also encourages HARC staff to conserve energy by turning off office equipment

at the end of the day and notifying the energy manager of planned absences.

Results. The iterative design process resulted in a highly efficient envelope, a low-maintenance GSHP system, strategic daylighting for greatly reduced electric lighting use, and a right-sized building that reflects the organization’s focus on sustainability (Figure 10). The HARC ZEB continues to benefit from ongoing monitoring and improvements, and the staff are eager to identify new ways to save energy. HARC plans to

transition into an “intelligent” building that optimizes its systems in real time—continuously improving building efficiency.

“We continue to fine-tune the set-points of the building and control ventilation based on occupancy levels. Our plug load management system allows us to control inefficiencies in the building.”

Dr. Carlos Gamarra,
HARC Energy Manager



Figure 10. As a research organization focused on sustainability and resiliency, HARC opted to turn its new office building into a “living laboratory” to develop new data and strategies for zero energy buildings. Photo: HARC.

NOTES

AEDG. Advanced Energy Design Guides, ASHRAE.

www.energy.gov/eere/buildings/advanced-energy-design-guides

ASHRAE/IES 2019. ANSI/ASHRAE/IES Standard 90.1-2019.

www.ashrae.org/technical-resources/90-1-portal;

www.ashrae.org/news/hvacindustry/2019-update-of-standard-90-1#:~:text=The%20newly%20updated%20ANSI%2FASHRAE,path%20for%20renewable%20energy%20treatment.

DOE ZEBs. U.S. Department of Energy, Office of Energy Efficiency and Renewable

Energy, Zero Energy Buildings webpage. www.energy.gov/eere/buildings/zero-energy-buildings

HARC. Houston Advanced Research Center, Building webpage.

<https://harcresearch.org/about/building/>

Olgun 2015. C. Guney Olgun. Presentation: Introductory Overview of Ground Source Heat Pump Technologies, Virginia Cooperative Extension Bioenergy Engineering Education Program. Appomattox, VA., April 13, 2015.

<https://aeeibse.wp.prod.es.cloud.vt.edu/wp-content/uploads/2015/06/Introduction-GSHP-Olgun.pdf>