



SOLAR ENERGY
TECHNOLOGIES OFFICE
U.S. Department Of Energy



Testing of a Particle-to-sCO₂ Heat Exchanger

Presented by: Megan Kirschmeier

Gen3 CSP Summit

August 26, 2021



Greg Mehos, Ph.D., P.E.



energy.gov/solar-office

Award # DE-EE0008368

Heat Exchanger (HX) Design

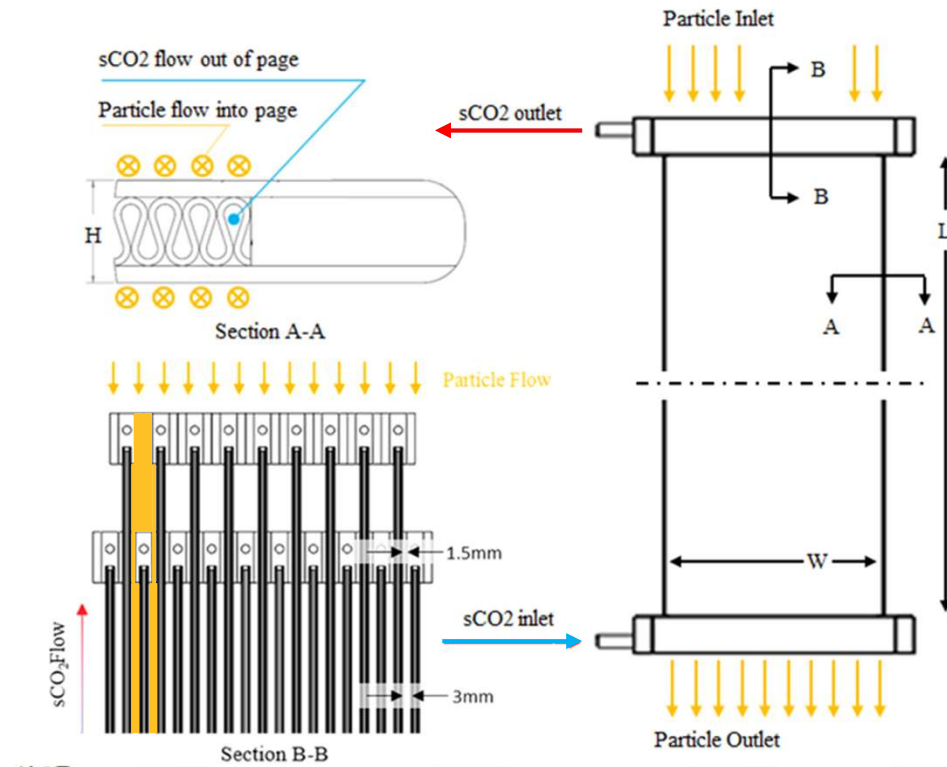

- Employ Brayton's internally finned heat exchanger (HX) cells
- Pure counterflow design
- Moving packed bed sand flow along external cell surfaces
- Vertically staggered cell arrangement
 - Allows small particle-side flow heights of 3mm

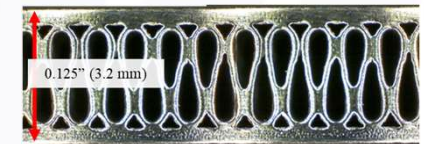

Test Campaigns

Lab-Scale Particle Flow Heat Transfer

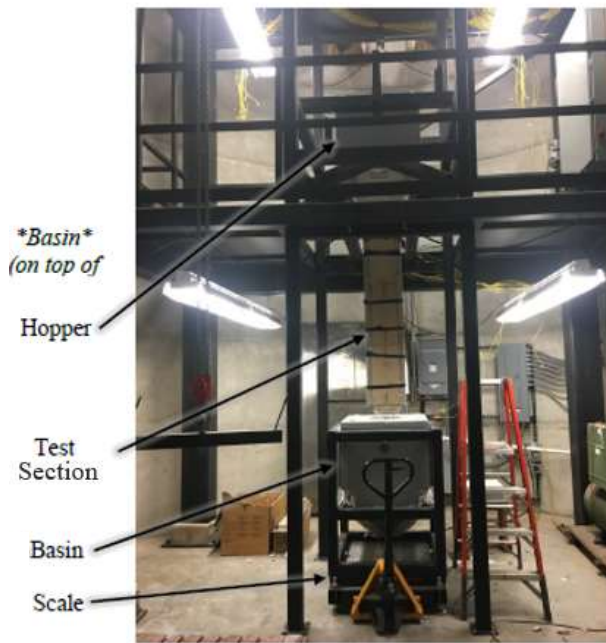

Subscale HX Performance



Test Campaigns

Lab-Scale Particle Flow Heat Transfer

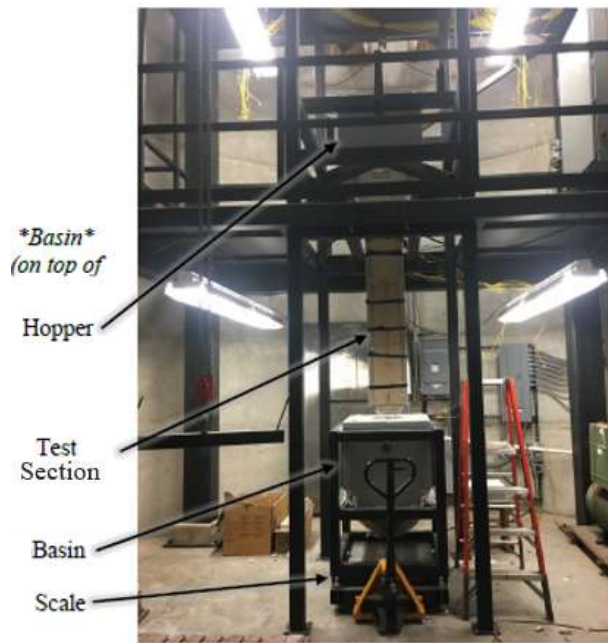

Subscale HX Performance



Experimental Test Setup

- Test rig constructed at University of Wisconsin-Madison to measure particle flow heat transfer performance
- Simulated half of single particle flow channel

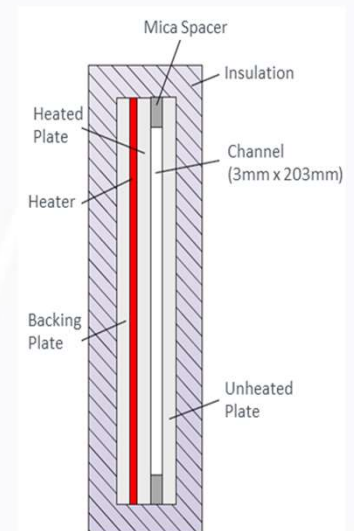
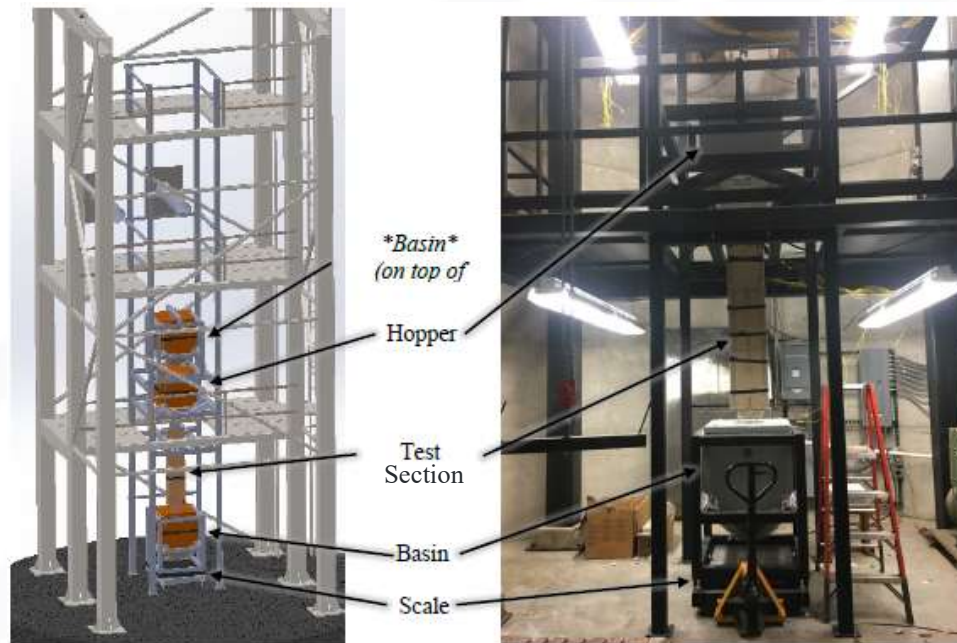
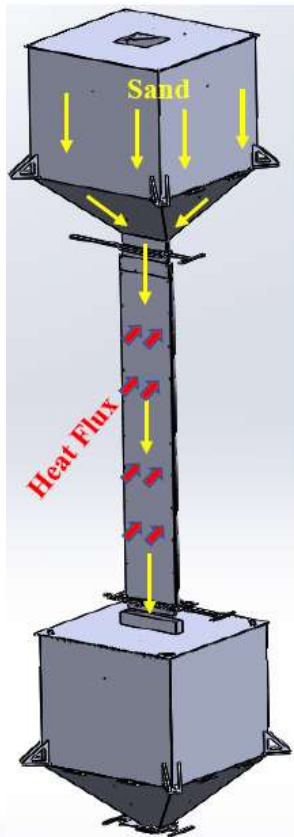

Heat Transfer Characterization



$$h = \frac{\dot{q}''}{(T_{s,H} - T_b)}$$

\dot{q}'' - heat flux
 $T_{s,H}$ - heated surface temperature
 T_b - bulk temperature

$$Nu = \frac{2bh}{k_b}$$

b - plate spacing
 k_b - bulk effective thermal conductivity

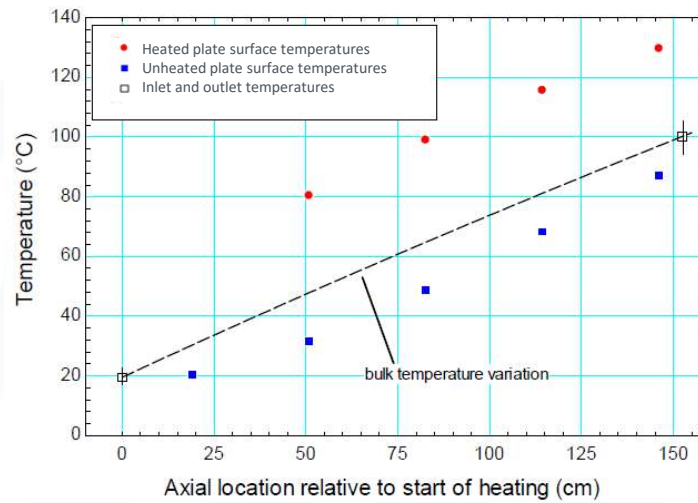

Results

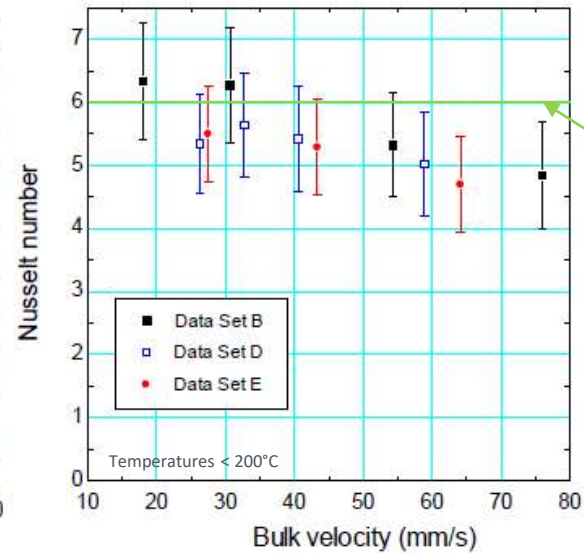
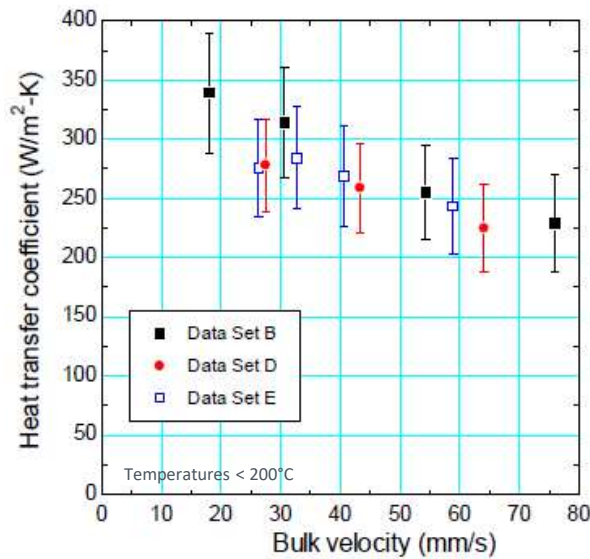

Laminar FD solution for plug flow

- Decrease in heat transfer observed with increasing flow rate
- Slight reduction in heat transfer compared with continuum solution observed in large portion of data

Test Campaigns

Lab-Scale Particle Flow Heat Transfer

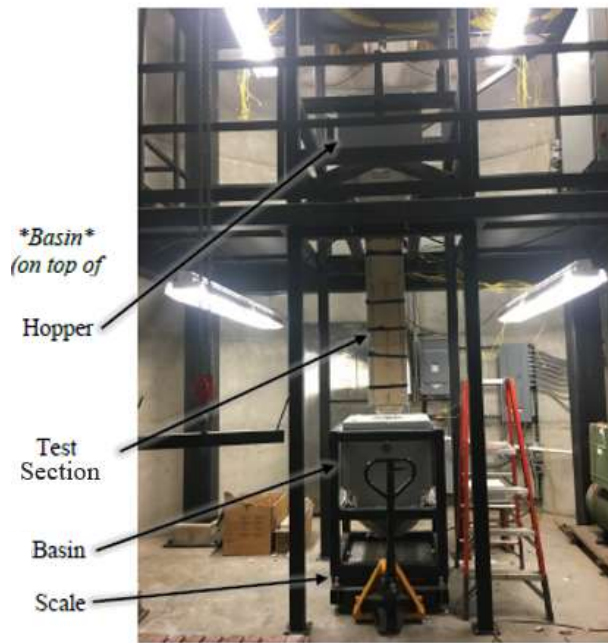

Subscale HX Performance



Test Tower



- Feed Bin
- Particle Preheater
- Heat Exchanger
- Flow Control Valve
- Collection Bin
- Load Cells

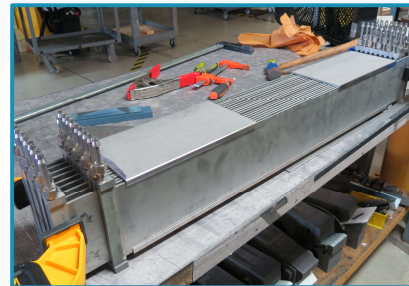
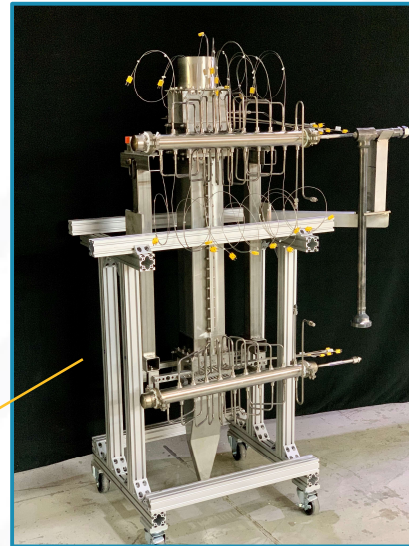

- ~16kW_t subscale test article
- Utilize CO₂ circulator skid constructed at Brayton
- Objectives:
 - Gain experience in fabrication
 - Validate performance models
 - Demonstrate operability

Charging Operation

PARAMETER	UNITS	GAS	PARTICLES
Inlet Temperature	°C	730	568
Outlet Temperature	°C	583	715
Inlet Pressure	MPa	25	-
Flow Rate	kg/s	0.085	0.0943

Discharging Operation

PARAMETER	UNITS	GAS	PARTICLES
Inlet Temperature	°C	553	715
Outlet Temperature	°C	700	568
Inlet Pressure	MPa	25	-
Flow Rate	kg/s	0.085	0.0943

Test Article

PARAMETER	UNITS	PROPOSED	TEST ARTICLE
Gas Flow Height	mm	2.0	2.0
Particle Flow Height	mm	3.0	3.0
Min. Particle Flow Width	mm	1.5	1.5
Cell Width	m	0.203	0.102
Cell Length	m	1.650	0.750

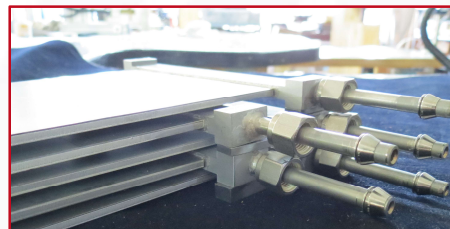
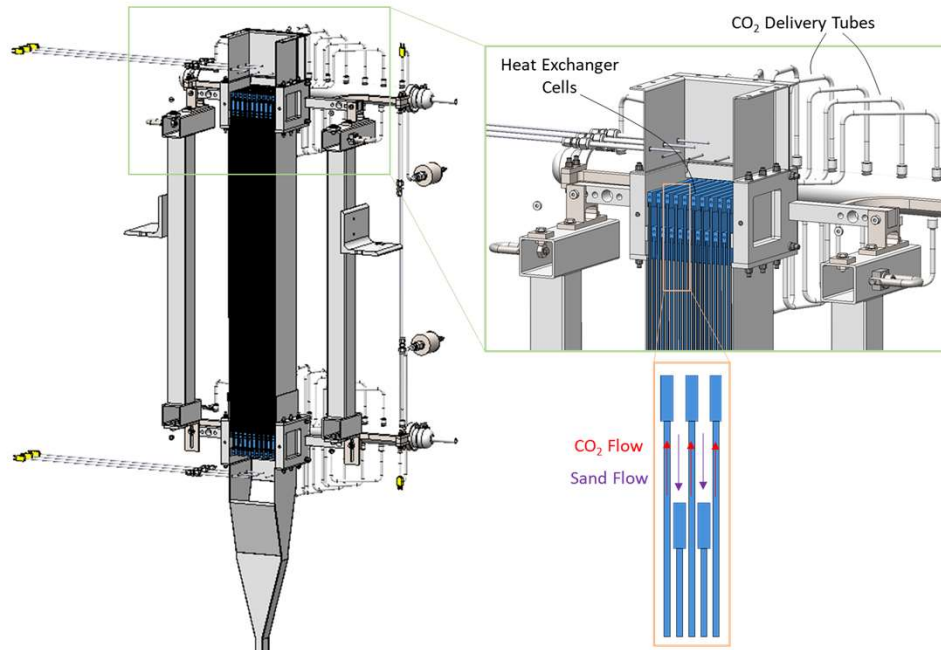
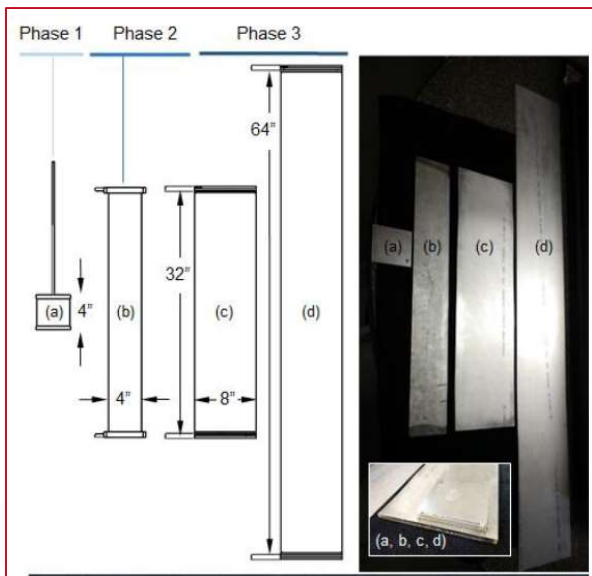

HX Testing Results

Test Cases

Test #	Operating Mode	Particle Inlet Temp (°C)	CO2 Inlet Temp (°C)	CO2 Inlet Pressure (MPa)	Capacitance Rate Ratio
1	Charging	6.6	205.4	4.70	0.89
2	Charging	109.6	338.4	4.55	0.86
3	Charging	26.5	261.6	9.06	0.88
4	Charging	143.6	395.8	8.37	0.93
5	Charging	211.3	517.7	8.24	0.96
6	Discharging	280.5	208.3	10.4	0.91
7	Discharging	350.3	302.3	9.4	0.90
8	Charging	5.6	515.6	9.08	0.80
9	Discharging	254.0	154.7	8.98	0.95

- Ultimate DP operating conditions (700°C, 25MPa) have not yet been achieved
 - Max temperature = 520°C
 - Max CO₂ pressure = 10.4MPa

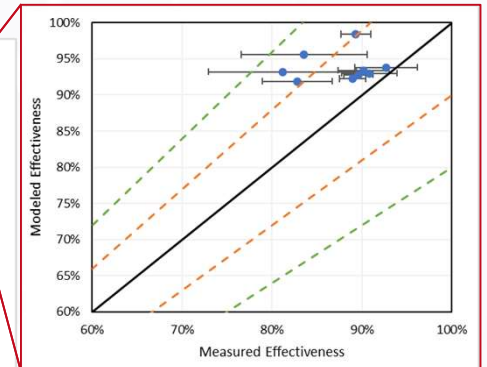
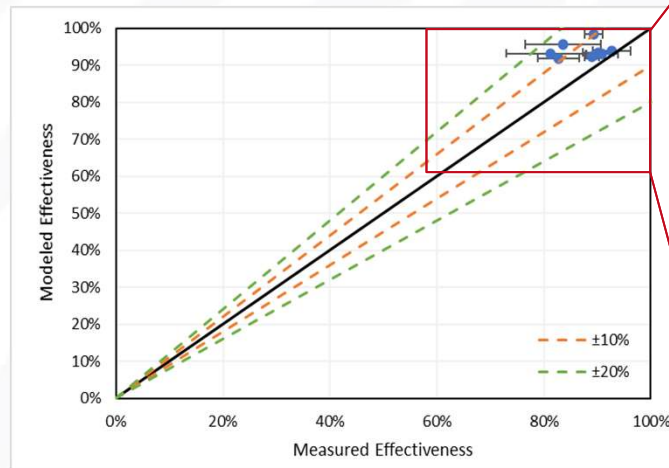
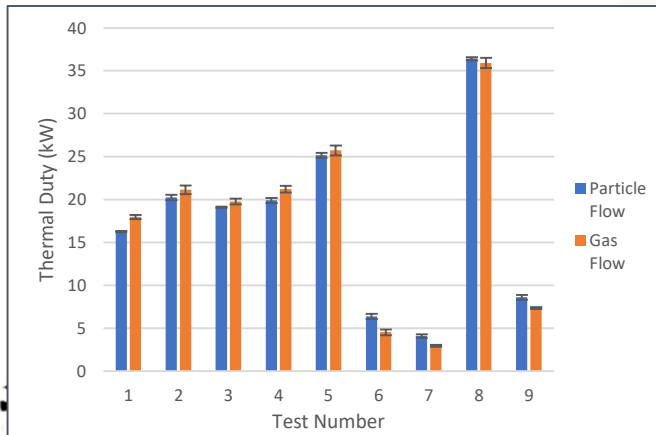
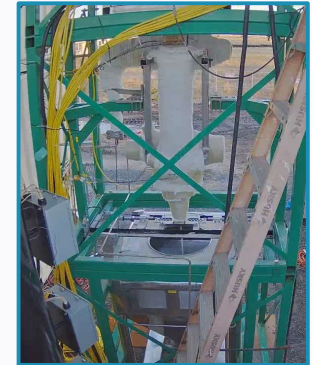

HX Performance Results

Test Cases

Test #	Operating Mode	Particle Inlet Temp (°C)	CO2 Inlet Temp (°C)	CO2 Inlet Pressure (MPa)	Capacitance Rate Ratio
1	Charging	6.6	205.4	4.70	0.89
2	Charging	109.6	338.4	4.55	0.86
3	Charging	26.5	261.6	9.06	0.88
4	Charging	143.6	395.8	8.37	0.93
5	Charging	211.3	517.7	8.24	0.96
6	Discharging	280.5	208.3	10.4	0.91
7	Discharging	350.3	302.3	9.4	0.90
8	Charging	5.6	515.6	9.08	0.80
9	Discharging	254.0	154.7	8.98	0.95

- Measured overall HX heat transfer coefficients (U) lower than expected from model
- Complete heat loss analysis still pending
- One parameter with high uncertainty in the model is the near-wall effective thermal conductivity
 - Quick sensitivity analysis shows model results are sensitive to this parameter
 - Baseline: Botterill & Denloye (1978)

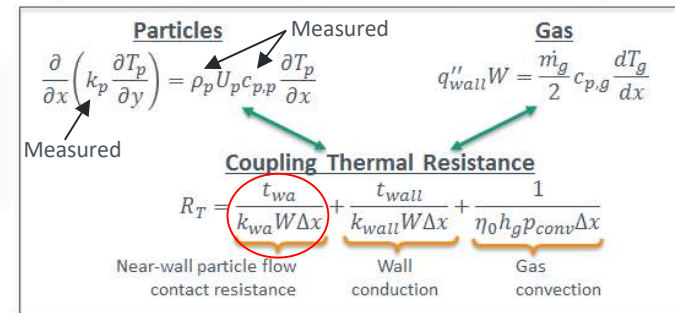
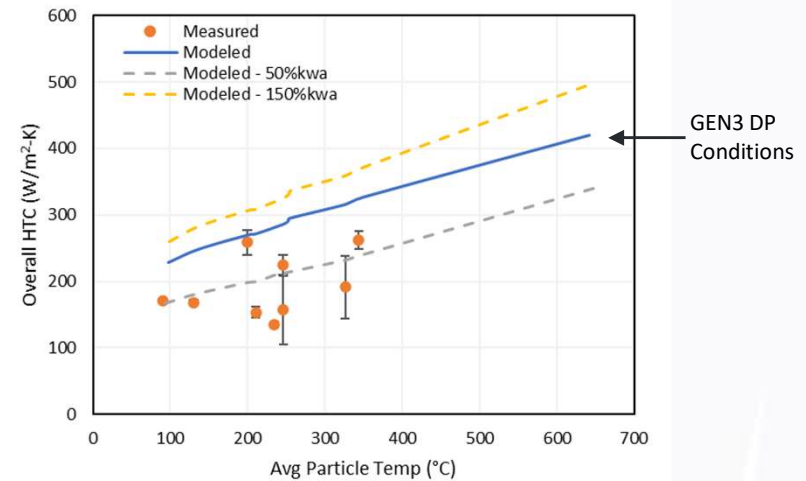

Summary/Future Work

- Preliminary HX performance results are encouraging, but require further analysis
- Additional HX performance testing scheduled to begin in the next month or two
 - Will strive to achieve design point operating conditions
- Model refinement to follow testing

Gen3CSP

Bringing together *the people and the pieces* for an

INTEGRATED CSP SYSTEM

Thank you!

megan@braytonenergy.com

