



## Lakeview, Oregon, Disposal/Processing Sites UMTRCA Title I sites

This fact sheet provides information about the **Lakeview disposal/processing sites**. These sites are managed by the **U.S. Department of Energy Office of Legacy Management under Title I of the Uranium Mill Tailings Radiation Control Act of 1978**.

The Lakeview disposal site is approximately 7 miles northwest of the town of Lakeview on 40 acres of land historically known as the Collins Ranch. The relocated RRM from the Lakeview processing site was stabilized in the approximately 16-acre Lakeview disposal cell, which was closed on June 29, 1988. The cell is located near the northern end of Goose Lake Valley, a large, flat mountain valley at an elevation of 4,950 feet above sea level. Vegetation consists of pine forest in the surrounding higher mountain areas and grasses, sage, and scrub brush in the foothills and valley. The predominant land use in the sparsely populated region is grazing.

### Site Information and History

The Lakeview, Oregon, Processing Site is a former uranium ore processing facility located approximately 1.5 miles north-northwest of the town of Lakeview in Lake County, Oregon, and 16 miles north of the California/Oregon border. Lakeview Mining Company built the mill in 1958 and operated the facility for three years. During this time, the mill processed approximately 130,000 tons of uranium ore. No uranium ore was processed at the site after 1961. The uranium milling process produced radioactive tailings, a predominantly sandy material, and other process-related residual radioactive material (RRM). From 1986 to 1988, the RRM was removed from the site in a project funded by the U.S. Department of Energy (DOE). A total of 926,000 cubic yards of uranium mill tailings and other process-related solid waste were removed from the processing site and placed in an engineered disposal cell at the Lakeview, Oregon, Disposal Site.

The 258-acre former processing site is located on private land and includes areas formerly used as a 30-acre tailings pile, seven raffinate ponds that covered a total of 69 acres, and mill buildings that previously contained RRM. Raffinate is the spent solution remaining after removal of uranium by solvent extraction. A lumber company purchased the mill site property in 1978 and used some of the raffinate ponds and buildings in its operations. Portions of the former processing site have changed ownership several times since the processing mill closed. However, a lumber company continues to use some of the former mill buildings. Approximately 170 acres of the former processing site was bought by a solar company in 2016 and is being used as a solar farm.



50182002 05/11/2020 10:46:57 AM

Locations of the Lakeview, Oregon, Sites.

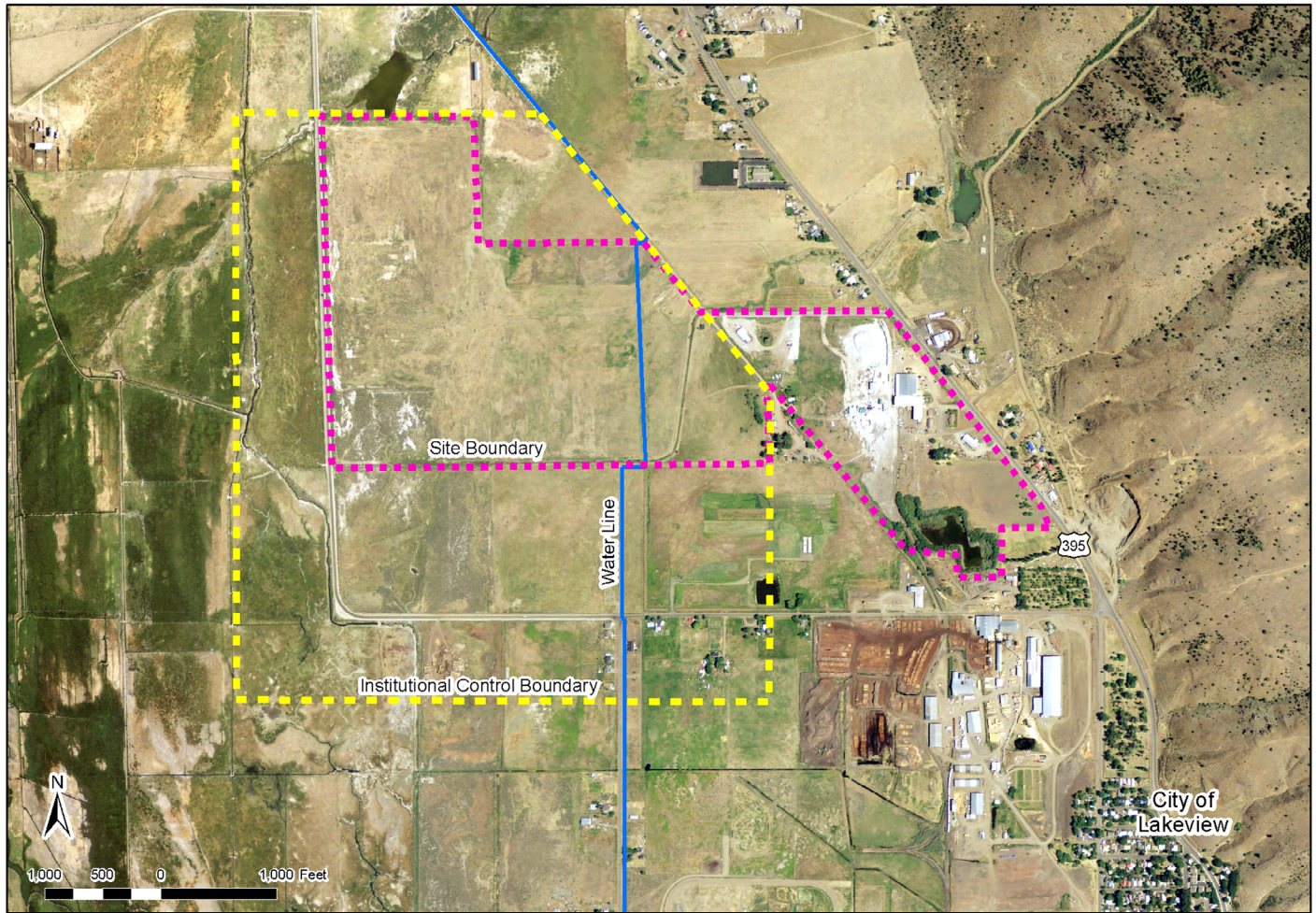

*Institutional Control Boundary, Site Boundary, and Water Line at the Lakeview Processing Site.*

## Regulatory Setting

Congress passed the Uranium Mill Tailings Radiation Control Act (UMTRCA) in 1978 (Public Law 95-604), and DOE remediated 22 inactive uranium ore processing sites under the Uranium Mill Tailings Remedial Action Project in accordance with standards promulgated by the U.S. Environmental Protection Agency in Title 40 *Code of Federal Regulations* (CFR), Part 192. Subpart B of 40 CFR 192 regulated cleanup of contaminated groundwater at the processing sites. The RRM was encapsulated in U.S. Nuclear Regulatory Commission (NRC)-approved disposal cells. NRC general license for UMTRCA Title I sites is established in 10 CFR 40.27. The Lakeview disposal site was included under the general license in 1995.

## Processing Site

The RRM, which existed at the processing site for approximately 30 years until 1988, had the potential for contaminating the underlying groundwater. The uppermost alluvial aquifer at the processing site consists of lake sediments intertwined with sands and gravels shed from nearby uplands. These sediments are hydraulically connected but partially separated by the layers of clayey lake sediments. In the former processing site area and in areas south of the

site, depth to the uppermost aquifer is approximately 30 feet, and groundwater flows southwest at rates ranging from 50 to 160 feet per year. Groundwater from a geothermal artesian source northeast of the site flows southwest beneath the western portion of the site. The geothermal groundwater also feeds springs that surface north of the site. Due to the proximity of groundwater to the surface and the groundwater flow rate and direction, the hydrogeologic setting is conducive to percolation and downgradient transport.

Alluvial groundwater beneath the Lakeview processing site was contaminated by former uranium ore processing operations and from nearby natural geothermal activity. The uppermost aquifer in the former mill site area has elevated concentrations of arsenic, boron, chloride, sodium, manganese, and sulfate relative to EPA drinking water standards. However, these constituent concentrations (with the exception of manganese) are also elevated in background water samples and are mostly attributed to natural geothermal activity and the natural high salt content of soil in the area. Elevated concentrations of sulfate and manganese in groundwater are partially attributed to the connection between the RRM and the land surface in the location of the former tailings pile. Higher manganese concentrations have also been reported in association with wastes from

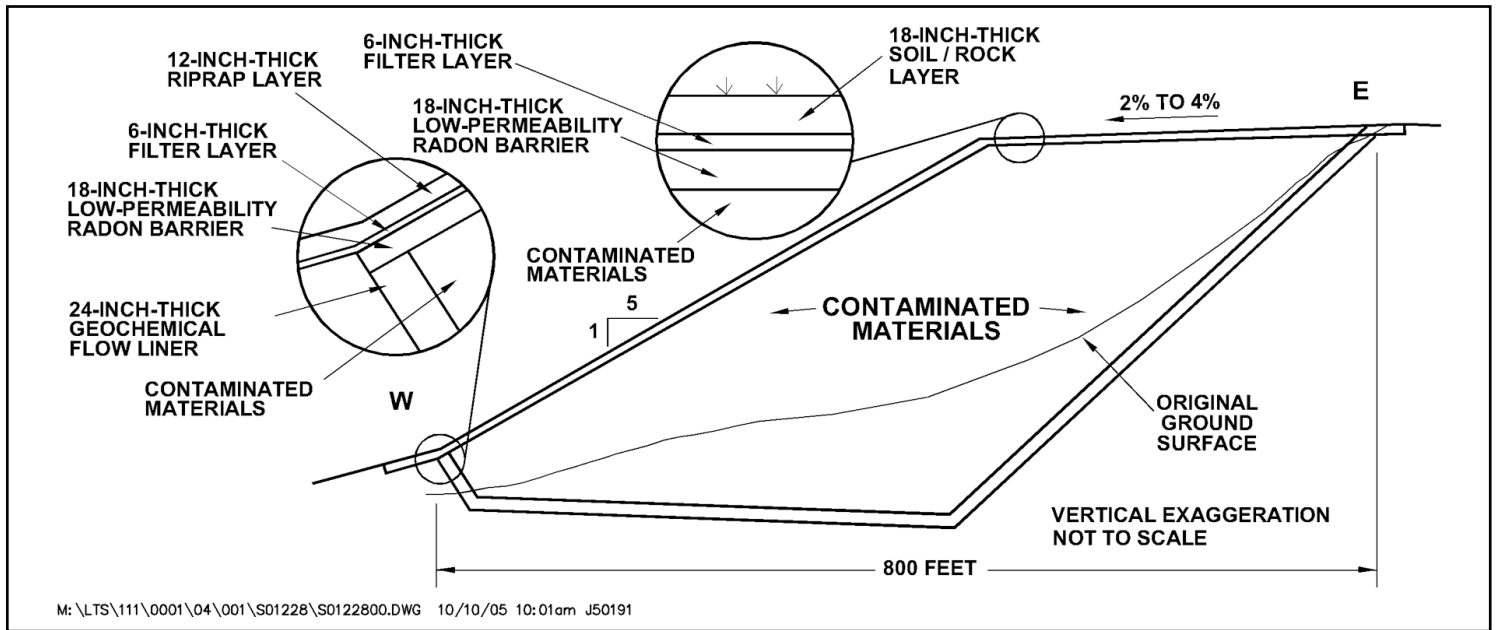

West-East Cross Section of the Lakeview Disposal Cell.

lumber milling activities, which also took place at the site. Concentrations of all applicable 40 CFR 192 listed constituents identified in groundwater beneath the former processing site have declined to levels below their respective groundwater quality standards or background levels.

### Compliance Strategy

The DOE compliance strategy at the Lakeview processing site is no remediation, and no further actions. This strategy is based on the presence of widespread ambient contamination not related to milling activities. Because sulfate and manganese are not included as regulated constituents under 40 CFR 192, and their presence in groundwater downgradient of the site is partially attributed to the uranium milling operations, DOE will continue voluntary monitoring of these constituents as a best management practice.

### Institutional Controls

DOE established institutional controls at the Lakeview processing site to ensure protection of human health and the environment by limiting access to groundwater potentially affected by mill site-related activities. An institutional control boundary was established around the western part of the former mill site that includes land within and beyond the predicted extent of mill site-influenced groundwater, previously defined by groundwater with elevated sulfate concentrations. The controls consist of a requirement for hookup to a domestic water line and a requirement for the minimum depth of a domestic well.

DOE negotiated with the city of Lakeview and Lake County to increase the capacity of a domestic water line under construction in the institutional control area and funded the cost of the increase. In return, both the city and county passed ordinances requiring future landowners inside the institutional control boundary to obtain hookups to the new domestic water line or to drill a well to a depth that ensures satisfactory

water quality. The Oregon Water Resources Department, the state agency responsible for ensuring domestic well applications are reviewed and approved before drilling permits are issued, passed an ordinance requiring all new domestic wells within the institutional control boundary to be screened at a minimum depth of 250 feet below ground surface.

## Disposal Site

### Disposal Cell Design

The disposal cell measures approximately 1,050 feet by 800 feet and occupies an area of 16 acres on the 40-acre site. The cell contains about 926,000 cubic yards of contaminated material with a total activity of 42 curies of radium-226. A wire fence with warning signs surrounds the cell.

The cell is on a hillside that was excavated to contain a portion of the contaminated materials below the original grade. Contaminated materials were placed on a geochemical liner of low-permeability, clayey soil. The cell cover is a multicomponent system designed to encapsulate and isolate the contaminated materials. The cover consists of: (1) a low-permeability radon barrier (first layer placed over contaminated materials), (2) a sand filter/drainage layer, and (3) a soil/rock matrix layer on the top slope and rock (riprap) only on side slopes to protect against wind and water erosion. The top of the disposal cell supports native brush and grasses.

The cell design promotes rapid runoff of precipitation to minimize infiltration. Runoff flows down the 20 percent grade side slopes into a rock-lined diversion channel on the north and rock-lined toe drains on the west. The channel and the toe drains are armored with rock to dissipate energy and reduce the potential for erosion. The disposal site is underlain by as much as 1,000 feet of sand, silt, and lakebed clay.

Depth to bedrock is unknown but is estimated to be more than 1,000 feet below ground surface. Depth to groundwater beneath the disposal cell is about 100 feet.

## Legacy Management Activities

The DOE Office of Legacy Management (LM) will continue to monitor groundwater near the processing site on a voluntary basis and will maintain institutional controls to ensure continued protection of human health and the environment.

LM manages the disposal site according to a site-specific Long-Term Surveillance Plan (LTSP) to ensure the disposal cell continues to prevent release of contaminants to the environment. Under provisions of this LTSP, LM conducts annual inspections of the site to evaluate the conditions of surface features, performs site maintenance as necessary, and monitors groundwater to verify the continued integrity of the disposal cell.

In accordance with 40 CFR 192.02(a), the disposal cell is designed to be effective for 1,000 years, to the extent reasonably achievable, and, in any case, for at least 200 years. However, the general license has no expiration date, and LM's responsibility for the safety and integrity of the Lakeview disposal cell will last indefinitely.



## CONTACT INFORMATION

**IN CASE OF AN EMERGENCY AT THE SITE,  
CONTACT 911**

**LM TOLL-FREE EMERGENCY HOTLINE:  
(877) 695-5322**

Site-specific documents related to the **Lakeview, Oregon, Disposal/Processing Sites** are available on the LM website at [www.energy.gov/lm/lakeview-oregon-disposalprocessing-sites](http://www.energy.gov/lm/lakeview-oregon-disposalprocessing-sites)

For more information about LM activities at the **Lakeview, Oregon, Disposal/Processing Sites**, contact:  
**U.S. Department of Energy  
Office of Legacy Management  
2597 Legacy Way  
Grand Junction, CO 81503**

Email:  
[public.affairs@lm.doe.gov](mailto:public.affairs@lm.doe.gov)

DOE Office of Legacy Management  
**(970) 248-6070**



[www.energy.gov/lm](http://www.energy.gov/lm)



[www.facebook.com/OfficeofLegacyManagement](https://www.facebook.com/OfficeofLegacyManagement)



[www.linkedin.com/showcase/office-of-legacy-management](https://www.linkedin.com/showcase/office-of-legacy-management)