



# Research and Development of a Ventilation-Integrated Comfort System

April 2021



## NOTICE

This work was prepared as an account of work sponsored by an agency of the United States Government. Neither the United States Government nor any agency thereof, nor any of their employees, nor any of their contractors, subcontractors or their employees, makes any warranty, express or implied, or assumes any legal liability or responsibility for the accuracy, completeness, or any third party's use or the results of such use of any information, apparatus, product, or process disclosed, or represents that its use would not infringe privately owned rights. Reference herein to any specific commercial product, process, or service by trade name, trademark, manufacturer, or otherwise, does not necessarily constitute or imply its endorsement, recommendation, or favoring by the United States Government or any agency thereof or its contractors or subcontractors. The views and opinions of authors expressed herein do not necessarily state or reflect those of the United States Government or any agency thereof, its contractors or subcontractors.

*Available electronically at Office of Scientific and Technical Information website  
([www.osti.gov](http://www.osti.gov))*

*Available for a processing fee to U.S. Department of Energy  
and its contractors, in paper, from:*

U.S. Department of Energy  
Office of Scientific and Technical Information  
P.O. Box 62  
Oak Ridge, TN 37831-0062

OSTI [www.osti.gov](http://www.osti.gov)  
Phone: 865.576.8401  
Fax: 865.576.5728  
Email: [reports@osti.gov](mailto:reports@osti.gov)

*Available for sale to the public, in paper, from:*

U.S. Department of Commerce  
National Technical Information Service  
5301 Shawnee Road  
Alexandria, VA 22312

NTIS [www.ntis.gov](http://www.ntis.gov)  
Phone: 800.553.6847 or 703.605.6000  
Fax: 703.605.6900  
Email: [orders@ntis.gov](mailto:orders@ntis.gov)



# Research and Development of a Ventilation-Integrated Comfort System

*Prepared for:*

U.S. Department of Energy Building America Program  
Office of Energy Efficiency and Renewable Energy

*Prepared by:*

Srikanth Puttagunta  
Robb Aldrich  
Barnett Cleary  
Steven Winter Associates, Inc.  
61 Washington St.  
Norwalk, CT 06854

April 2021

---

*Suggested Citation*

Puttagunta, Srikanth, Robb Aldrich, and Barnett Cleary. 2021. *Research and Development of a Ventilation-Integrated Comfort System*. Norwalk, CT. DOE/GO-102021-5491. [www.nrel.gov/docs/fy21osti/78352](http://www.nrel.gov/docs/fy21osti/78352).

This material is based upon work supported by the Department of Energy's Office of Energy Efficiency and Renewable Energy (EERE) under the Building Technologies Office under Award Number EE0007572.

The work presented in this EERE Building America report does not represent performance of any product relative to regulated minimum efficiency requirements.

The laboratory and/or field sites used for this work are not certified rating test facilities. The conditions and methods under which products were characterized for this work differ from standard rating conditions, as described.

Because the methods and conditions differ, the reported results are not comparable to rated product performance and should only be used to estimate performance under the measured conditions.

# FOREWORD

The U.S. Department of Energy (DOE) Building America Program has spurred innovations in building efficiency, durability, and affordability for more than 25 years. Elevating a clean energy economy and skilled workforce, this world-class research program partners with industry to leverage cutting-edge science and deployment opportunities to reduce home energy use and help mitigate climate change.

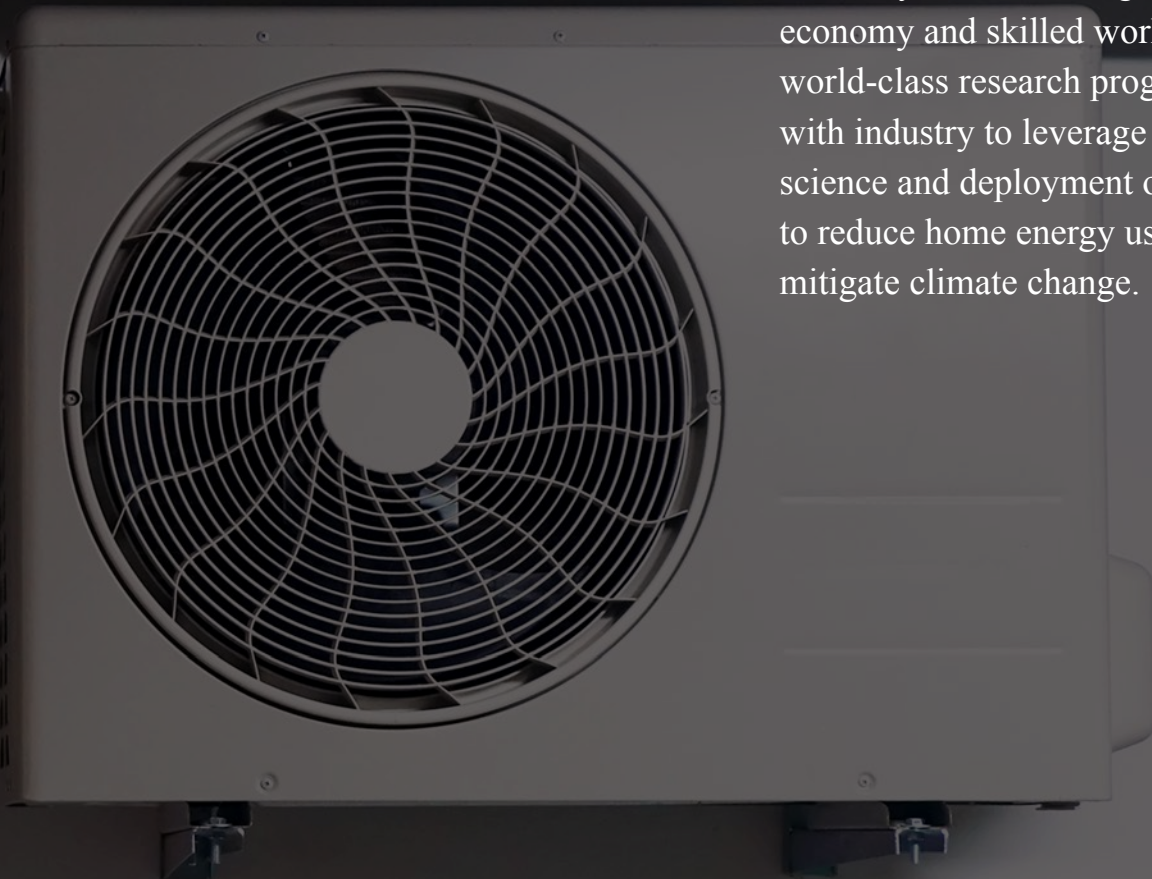

In cooperation with the Building America Program, the Steven Winter Associate's team is one of many [Building America teams](#) working to drive innovations that address the challenges identified in the program's [Research-to-Market Plan](#).

This report, "Research and Development of a Ventilation-Integrated Comfort System," describes an R&D effort to lower the cost and ease the integration of energy recovery ventilation systems in low-load homes.

As the technical monitor of the Building America research, the National Renewable Energy Laboratory encourages feedback and dialogue on the research findings in this report as well as others. Send any comments and questions to [building.america@ee.doe.gov](mailto:building.america@ee.doe.gov).



# ACKNOWLEDGMENTS

The work presented in this report was funded by the U.S. Department of Energy (DOE), Office of Energy Efficiency and Renewable Energy, Building Technologies Office.

The authors greatly appreciate the support from Therma-Stor, CORE Energy Recovery Solutions, and Mitsubishi Electric Trane US. Their contributions and expertise were invaluable throughout this effort.

## *Photo Credits*

*Cover, from top to bottom: Photos from iStock 182149008, 178447161, 184944590, 467972591*

*Page ii and iii: Photo from iStock 539128158*

*Page v: Photo from iStock 619534960*

*Page vi and vii: Photo from iStock 539128158*

*Page viii: Photo from iStock 178447161*

*Page ix and x: Figures from Steven Winter Associates, Inc.*



## LIST OF ACRONYMS

|      |  |
|------|--|
| AHU  | air handling unit  |
| cfm  | cubic feet per minute  |
| COP  | coefficient of performance   |
| ERV  | energy recovery ventilator   |
| HRV  | heat recovery ventilator   |
| HVAC | heating, ventilating, and air conditioning   |
| HVI  | Home Ventilating Institute   |
| MERV | minimum efficiency reporting value   |
| OA   | outdoor air  |
| RH   | relative humidity  |
| SA   | supply air   |
| scfm | standard cubic feet per minute (of air with density of 0.075 lbm/ft <sup>3</sup> ) |
| SWA  | Steven Winter Associates, Inc.   |
| VICS | ventilation-integrated comfort system  |

# EXECUTIVE SUMMARY

From an indoor air quality perspective, the best residential ventilation strategies include filtering outdoor air and distributing that air to all occupied parts of a home (USBBC 2013, DOE 2019, Harriman et al. 2019, PHIUS 2015). From an energy standpoint, it is desirable that energy be transferred from the exhaust air to the incoming outdoor air to limit heating and cooling impacts. Heat or energy recovery ventilators (HRVs or ERVs) can provide these functions, but researchers have seen many poor installations related to design, installation, and operation and maintenance.

More robust ventilation systems may involve an ERV with a dedicated duct distribution system and controls. Such a duct system can be costly to install, and many builders reduce these costs by connecting an ERV to a central heating and cooling duct system. Although this can sometimes be done effectively, researchers have seen consistent challenges with low,

inconsistent, or imbalanced flow rates; high electricity consumption; and—of greatest concern—outdoor air short-circuiting or not being delivered to occupied spaces at all. Most ERVs are designed to operate with their own duct system; they are not designed as an add-on to much larger heating, ventilating, and air-conditioning (HVAC) systems.

The ventilation-integrated comfort system (VICS) described in this report is expressly designed to integrate with low-capacity, efficient, ducted heating and cooling systems. There were four key developments that made the VICS practical and timely:

- **Smaller design loads.** With evolving energy codes and above-code programs, heating and cooling loads in new single- and multifamily buildings have dropped (DOE 2015, Puttagunta 2015).
- **Smaller-capacity heating and cooling equipment.** Heating and cooling manufacturers, especially manufacturers of air-source heat pumps, continue to introduce low-capacity systems.
- **Variable-speed fans.** Smaller, efficient, variable-speed blowers have become much more available and affordable.
- **Growing demand.** More above-code programs are requiring (or incentivizing) the use of balanced, heat recovery ventilation in new homes (DOE 2019, PHI 2018, PHIUS 2018).

With support from DOE's Building Technologies Office, Steven Winter Associates, Inc. (SWA) partnered with



Mitsubishi Electric Trane US, CORE Energy Recovery Solutions, and Therma-Stor LLC to design and test VICS prototypes. A conceptual diagram is shown in Figure ES-1, and the latest prototype (shown in Figure ES-2) was manufactured by Therma-Stor and tested in SWA’s facility in Norwalk, Connecticut. The ERV heat exchanger was provided by CORE, and the VICS was installed in conjunction with a 1-ton inverter heat pump provided by Mitsubishi.

The VICS device itself consists of the ventilation components that can be added to and integrated with a wide variety of small, efficient, forced-air heating and cooling systems. A variable-speed blower draws in outdoor air through the cross-flow heat exchanger core. After passing through the ERV core, tempered outdoor air is mixed with return air, enters the air handler (where air is heated or cooled if appropriate), and is distributed through the heating and cooling duct system. The air handler fan is set to run on low speed to distribute air even when there is not a heating or cooling call. A separate, variable-speed exhaust blower extracts a portion of return air (in this configuration), draws this air through the ERV core, and sends the air to exhaust ductwork. The size and variable-speed nature of these blowers ensure that ventilation flow rates are always met with no impact on heating or cooling performance.

Overall, the latest VICS prototype consumed 40–75 watts (W), including the air handler power, to deliver 50–120 cfm of whole-dwelling ventilation. The large, cross-flow ERV core performed to match manufacturer values (73% winter sensible effectiveness, 64% summer total effectiveness), but further improvements are possible.

A practitioner survey was performed later in the project period; among the 95 respondents, there was significant interest in the VICS concept and approach. The target installed cost of a commercial VICS product is \$2,000, and this is in-line with

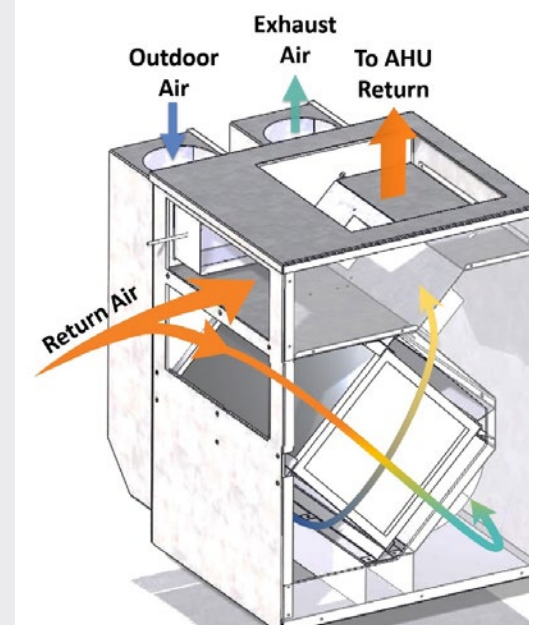

Figure ES-1. Conceptual diagram of the VICS



Figure ES-2. VICS beta prototype

installed costs given from practitioners. Hardware costs for the VICS will be higher than for other ERVs, but installation and integration will be simpler.

The VICS system researched and tested during this project will provide efficient, controllable, balanced energy recovery ventilation that is integrated with heating and cooling systems. The integration reduces space and ductwork needed for separate ventilation systems, and there are no compromises to heating, cooling, or ventilation performance. The integrated nature of the device also reduces risks for improper installation and commissioning. Even when using the air handler blower to distribute outdoor air, the total power consumption is lower than that of most available ERV products in the same airflow range. This system has the potential to offer very high-performance ventilation with much smoother and simpler installation than conventional systems. Discussions with manufacturers are ongoing.

## Table of Contents

|       |   |    |
|-------|---|----|
| 1     | Project Overview .....                              | 1  |
| 1.1   | Background and Problem Statement .....              | 1  |
| 1.2   | Opportunity .....                                   | 2  |
| 1.3   | Approach and Objectives .....                       | 2  |
| 2     | Phase I.....  | 4  |
| 2.1   | Preliminary Design.....                             | 4  |
| 2.2   | Phase I Objectives .....                            | 5  |
| 2.3   | Phase I Test Procedures.....                        | 6  |
| 2.4   | Phase I Test Results.....                           | 8  |
| 2.5   | Phase I Summary.....                                | 9  |
| 3     | Phase II: Ventilation Prototype with Heat Pump..... | 10 |
| 3.1   | Winter Testing.....                                 | 10 |
| 3.1.1 | Heat Pump Performance .....                         | 10 |
| 3.1.2 | Winter ERV Performance .....                        | 11 |
| 3.1.3 | Power Consumption.....                              | 13 |
| 3.1.4 | Frost Protection.....                               | 14 |
| 3.2   | Outdoor Air Supply Fan.....                         | 15 |
| 3.3   | Summer Testing .....                                | 16 |
| 3.3.1 | Heat Pump Performance .....                         | 16 |
| 3.3.2 | Latent Cooling and Coil Drying .....                | 18 |
| 3.3.3 | ERV Performance .....                               | 19 |
| 3.3.4 | Power Consumption.....                              | 20 |
| 3.4   | VICS and Heat Pump Interactions: Heating .....      | 21 |
| 3.5   | VICS and Heat Pump Interactions: Cooling .....      | 23 |
| 3.6   | Phase II Summary .....                              | 24 |
| 4     | Phase III: Beta Prototype and Testing .....         | 25 |
| 4.1   | Beta Prototype Design Considerations.....           | 25 |
| 4.1.1 | Fans and Flow Control.....                          | 25 |
| 4.1.2 | Core Selection.....                                 | 29 |

|       |   |    |
|-------|---|----|
| 4.1.3 | Frost Prevention .....                      | 30 |
| 4.1.4 | Beta Prototype Design .....                 | 32 |
| 4.2   | Phase III Research Questions .....          | 34 |
| 4.3   | Winter Testing.....                         | 35 |
| 4.3.1 | Maintaining Ventilation Flow Rates.....     | 35 |
| 4.3.2 | Frost Prevention .....                      | 36 |
| 4.3.3 | ERV Effectiveness .....                     | 38 |
| 4.3.4 | Power Consumption.....                      | 40 |
| 4.4   | Summer Testing .....                        | 41 |
| 4.4.1 | Maintaining Ventilation Flow Rates.....     | 41 |
| 4.4.2 | ERV Effectiveness .....                     | 42 |
| 4.4.3 | Power Consumption.....                      | 42 |
| 5     | Survey and Market Outreach .....            | 43 |
| 5.1   | Survey Questions and Results .....          | 44 |
| 5.2   | Survey Results Discussion .....             | 48 |
| 6     | Discussion.....                             | 50 |
| 6.1   | Meeting Initial Goals.....                  | 50 |
| 6.2   | Design Evolution.....                       | 51 |
| 6.2.1 | Size.....                                   | 53 |
| 6.2.2 | Effectiveness .....                         | 53 |
| 6.2.3 | Power .....                                 | 53 |
| 6.2.4 | Cost .....                                  | 54 |
| 6.3   | Market Potential .....                      | 54 |
| 6.4   | Next Steps .....                            | 56 |
|       | References.....                             | 57 |
|       | Appendix A. Instrumentation.....            | 60 |
|       | Appendix B. Calculations .....              | 63 |
|       | Appendix C. Propagation of Uncertainty..... | 65 |

## List of Figures

|   |    |
|---|----|
| Figure 1. Schematic of VICS layout .....  | 4  |
| Figure 2. Initial VICS prototype .....  | 5  |
| Figure 3. Schematic of the first VICS prototype with sensor locations highlighted .....   | 6  |
| Figure 4. Impact of modulating return air damper on total AHU flow and outdoor airflow .....  | 9  |
| Figure 5. Impact of ventilation set point on AHU flow rates and COP during winter testing .....   | 11 |
| Figure 6. Sensible effectiveness ( $\epsilon$ ) values at various flow rates; flow is expressed in standardized cubic feet per minute (scfm) .....  | 12 |
| Figure 7. Sensible effectiveness at different temperatures and flow rates.....  | 12 |
| Figure 8. VICS power consumption at various flow rates.....   | 13 |
| Figure 9. Tempering frost prevention illustration: the tempering damper modulates, allowing warm return air (red arrow) to mix with outdoor air (blue arrow) before entering core (pink arrow)..... | 15 |
| Figure 10. Retrofit intake fan.....   | 16 |
| Figure 11. Ventilation set point and heat pump COP. Outdoor temperature is 85°–90°F, and loads are 4,000-5,000 Btu/h. Higher ventilation rates appear to have no impact on the heat pump COP.....   | 17 |
| Figure 12. Humidity ratio during and after calls for cooling.....   | 19 |
| Figure 13. Average ERV effectiveness at different flow rates from Table 7 .....   | 20 |
| Figure 14. VICS power consumption with use of retrofitted intake fan.....   | 21 |
| Figure 15. Heating capacity and COP vs. return air temperature .....  | 22 |
| Figure 16. Impact of entering wet-bulb temperature on capacity and efficiency .....   | 23 |
| Figure 17. Fan curves from testing Rosenberg Ecofit N45-A1 at various voltage settings.....   | 26 |
| Figure 18. Fan curves for Rosenberg Ecofit N45-A1 from manufacturer literature .....  | 27 |
| Figure 19. Fan curves from Fans-Tech (dashed) and SWA (solid) for Fans-Tech 140-mm constant flow blower.....  | 28 |
| Figure 20. The tempering damper allowed room air to mix with outdoor air before passing through the core .....  | 32 |
| Figure 21. Tempering air for frost prevention drawn from AHU supply plenum .....  | 32 |
| Figure 22. SWA CAD design of VICS beta prototype.....   | 33 |
| Figure 23. Manufacturer design revisions for improved manufacturability .....   | 33 |
| Figure 24. Beta prototype in Therma-Stor’s factory.....   | 34 |
| Figure 25. Beta prototype installed in Connecticut .....  | 34 |
| Figure 26. Ventilation flow rates are maintained at set point with changing AHU operation .....   | 36 |
| Figure 27. Impact of frost-prevention tempering damper actuation on air temperature entering core.....  | 37 |
| Figure 28. Outdoor airflow rates maintained during changes of set point and tempering damper position.....  | 38 |
| Figure 29. The entire cabinet was sealed and leak tested using a Duct Blaster.....  | 39 |

Figure 30. After sealing, SWA insulated portions of the ERV where air leaves the core with 0.5 in. of foam..... 40

Figure 31. Two-page summary document released by SWA ..... 44

Figure 32. Primary work regions of respondents..... 45

Figure 33. Most common building types ..... 45

Figure 34. Number of dwellings ..... 45

Figure 35. Type of ventilation ..... 45

Figure 36. ERV or HRV ..... 46

Figure 37. Filtration level ..... 46

Figure 38. Local ventilation practices..... 46

Figure 39. AHU orientation ..... 46

Figure 40. Respondents were asked to select all above-code programs in which they participate..... 47

Figure 41. Typical ventilation ranges ..... 47

Figure 42. Typical cost per dwelling if using H/ERVs..... 47

Figure 43. Important VICS features..... 48

Figure 44. Respondents selected any/all desired control features ..... 48

Figure 45. VICS power at several flow rates compared to commercially available ERVs ..... 54

Figure 46. Residential H/ERV sales history and forecast..... 55

Figure 47. General schematic with measurement locations..... 60

Figure 48. Six thermistors and four TRH sensors were installed to measure properties of the air entering the AHU (location 8 in Figure 47)..... 62

Figure 49. Four thermistors and two TRH sensors were installed in each quadrant where air left the ERV core..... 62

## List of Tables

Table 1. Performance Goals for Phase I Alpha Prototype ..... 5

Table 2. Summary of Test Results with 120 cfm Outdoor Air Set Point and AHU Flow Rate Set to “Low” ..... 8

Table 3. Heat Pump Representative Performance Values ..... 10

Table 4. Selected Phase II Testing Conditions and Results..... 14

Table 5. Representative Summer Testing Summary..... 17

Table 6. Heat Pump Cooling Performance at Various Ventilation Rates..... 18

Table 7. Summer ERV Effectiveness at Various Flow Rates and Outdoor Conditions ..... 19

Table 8. Potential for Increased COP from Manufacturer Literature ..... 22

Table 9. Rosenberg Ecofit N45-A1 Benchtop Flow Test Results ..... 27

Table 10. Comparison of Fans-Tech vs. Rosenberg Power Consumption When Installed in the VICS Prototype..... 29

|  |    |
|--|----|
| Table 11. Comparison of Manufacturer Values for Several ERV Cores at 120 cfm at HVI Test Conditions .....                | 30 |
| Table 12. Typical Winter Sensible Effectiveness with Outdoor Air Temperatures of 30°–40°F. 38                            |    |
| Table 13. Typical Power Consumption During Winter Tests; Power Values Do Not Include the AHU Fan Energy of 30–35 W ..... | 41 |
| Table 14. Sample Summer Performance Tests .....  | 42 |
| Table 15. Typical Power Consumption of VICS with Fans-Tech 140-mm Blowers and 120-mm Ecofit Blowers .....                | 42 |
| Table 16. Performance Goals and Results .....  | 50 |
| Table 17. Average and Maximum HVI Rated Performance.....   | 53 |
| Table 18. CSA 439 and HVI Test Conditions .....  | 53 |
| Table 19. Measurement Instruments.....   | 61 |
| Table 20. Example Readings and Uncertainty Values from a Cooling Season Test.....  | 65 |
| Table 21. Example Values and Uncertainties From a Ventilation-Only Test .....  | 68 |

# 1 Project Overview

## 1.1 Background and Problem Statement

The homebuilding industry has taken dramatic steps with respect to energy efficiency in recent years, and even homes that are merely code-compliant today are much more efficient than homes built a decade ago. The *Building America Research-to-Market Plan* (Werling 2015) identifies a key challenge for builders today: finding the right-sized heating and cooling equipment for newer, more efficient homes. One study surveyed hundreds of homes and apartments and found that 75% of apartments had heating and cooling design load below 12 kBtu/h (Puttagunta 2015). Most new single-family homes (75%) had heating design loads of 25 kBtu/h or below; most had design cooling loads of 12 kBtu/h or lower. In these homes, only 1% of heating systems and 6% of cooling systems were right sized per Air Conditioning Contractors of America guidelines (ACCA 2014, 2016). The drop in loads—and lack of systems readily available to meet these small loads—is a challenge identified in the *Research-to-Market Plan*.

Builders (and homeowners) are also encountering challenges related to ventilation and indoor air quality. Research has found that filtering incoming fresh air (with at least minimum efficiency reporting value [MERV] of 13) to remove particles in the 2.5  $\mu\text{m}$  range can improve indoor air quality (Harriman et al. 2019). ASHRAE Standard 62.2 (ASHRAE 2013) requires basic levels of ventilation, but it does not have requirements related to balanced or unbalanced ventilation. Other programs, however, such as LEED for Homes (USGBC 2013), Passive House (PHI 2018, PHIUS 2018), and DOE Zero Energy Ready Homes (DOE 2019), require or strongly encourage balanced heat recovery ventilation for both energy and indoor air quality reasons. In conversations with builders and developers, the incremental cost for installing heat or energy recovery ventilation systems (HRVs or ERVs) is still high (Holladay 2012). A survey of practitioners described in Section 5 showed that installed costs of \$1,200–\$5,000 per dwelling are common.

In many dwellings, space conditioning and whole-building ventilation are provided by separate mechanical systems. For cost reasons, however, a dedicated distribution system for dwelling-unit ventilation is uncommon. To lower incremental costs of HRVs and ERVs, contractors often attach ventilators to heating and/or cooling distribution systems. In inspecting and testing many such systems, the authors have often found short-circuiting problems (where fresh outdoor air is exhausted before it is distributed to occupied space). The furnaces or air handling units (AHUs) often have much larger blowers than the HRV or ERV, and the smaller ventilation blowers cannot compete with the AHU blowers. Desired ventilation flow rates are often not achieved because of these pressure imbalances and poor integration.

There are a few products on the market that have sought to integrate HRVs with heating and cooling. However, these products have not achieved substantial market penetration. Some products also have significant drawbacks with respect to electricity use, waste of thermal energy, overall heating/cooling capacity, control, or cost.



## 1.2 Opportunity

The authors note an increased availability (and lower cost) of small-capacity, variable-speed blowers available on the market today. These can deliver higher efficiency and better control than older technology, and SWA believes more residential ERVs and HRVs will make use of this technology.

Variable-speed air-source heat pumps are one promising exception to the lack of small-capacity heating and cooling systems. These versatile systems come in a wide range of capacities and have been shown to provide efficiency and comfort even in colder climates (Williamson 2015, Cadmus 2016, Cadmus 2017). The dramatic drop in heating and cooling loads coupled with the proliferation of small-capacity air-source heat pumps presents an opportunity: airflow rates needed for small heating and cooling systems (200–400 cfm) are much closer to flow rates needed for ventilation (40–120 cfm). As these air-source heat pumps have variable-speed compressors and fans, there is potential for a smart, integrated, modulating system to efficiently meet both thermal loads and ventilation needs. This research and development effort takes advantage of the versatility of these new air-source heat pump systems and the growing availability of small, variable-speed blowers to create an efficient, versatile, cost-effective, and integrated ventilation solution for low-load dwellings. This system under development is called VICS: ventilation-integrated comfort system.

## 1.3 Approach and Objectives

Overall, SWA sought to design, construct, evaluate, and optimize a fully integrated space-conditioning and ventilation solution for low-load dwellings. The concept of combining outdoor air distribution with heating and cooling distribution itself is not new, but it has not been done with great success, efficiency, or cost-effectiveness. Large U.S. manufacturers of heating and cooling equipment have been slow to adapt to the low capacities required for new low-load dwellings despite the rise in demand. As a result, many overseas manufacturers of air-source heat pumps have experienced tremendous market growth in the United States, and many have made large investments in U.S. manufacturing. These heat pump manufacturers, however, generally do not manufacture residential ventilation equipment. This project sought to bridge this gap to help develop and demonstrate integrated solutions that are very efficient, provide superior comfort and indoor air quality, and are cost-effective. For support in this effort, SWA partnered with (1) Mitsubishi Electric, one of the leading manufacturers of inverter-driven heat pumps, (2) Thermo-Stor, the largest dehumidifier manufacturer in the United States, and (3) CORE Energy Recovery Solutions (previously dPoint Technologies), the largest energy recovery core manufacturer in North America.

The effort followed the general outline below:

### Phase I

- Design and planning. SWA worked with partners to outline the performance parameters and design approach.

- Market and stakeholder assessment. The authors interviewed builders and developers about their current ventilation practices and interest in an integrated ERV system.
- Design and construction of the first “alpha” prototype.
- Benchtop testing of alpha prototype (without heat pump operational).

#### Phase II

- Integration of alpha prototype with the Mitsubishi air-source heat pump.
- Testing fully functional alpha prototype during heating and cooling seasons.

#### Phase III

- Design and construction of “beta” prototype (based on alpha findings).
- Testing of beta prototype during heating and cooling seasons.
- Market survey and outreach to more specifically identify market niches, needs, and price points.
- Design of preproduction prototype.

The integrated ventilation system utilizes an ERV core incorporated on the return side of a low-capacity heat pump fan coil. Key questions in this research and development effort include the following.

- Can the system integrate with efficient, forced-air heating and cooling systems without adverse impacts on heating or cooling operation?
- What flow rates are possible? Can the system provide the desired range of 30–120 cfm?
- Can ventilation flow rates be maintained regardless of heating/cooling operation?
- What is the power consumption? Does the system achieve the target of 70 W at 120 cfm of ventilation, including air handler operation?
- What are the sensible and total recovery efficiencies at design conditions? Does the system meet the goals of 70% sensible recovery efficiency and 50% total recovery efficiency?
- Can the system have a footprint similar to that of a small, conventional air handler and fit in a mechanical closet?
- Can the system include standard MERV 13 filtration of outdoor air?

## 2 Phase I

The initial VICS alpha prototype used negative pressure created by the AHU to draw in outdoor air through the ERV core. Phase I testing focused on pressure and airflow dynamics of this configuration, and test results showed that flow and pressure targets were met, though there were limitations at higher flow rates and static pressures as described in Section 2.4. It is worth noting, however, that during Phase II, this initial approach was deemed *not* viable because of the substantial efficiency impacts on the heat pump. Future prototypes incorporated an outdoor air blower as described in Section 3 and in subsequent sections.

### 2.1 Preliminary Design

A basic schematic of the first VICS design is shown in Figure 1, and images of the first prototype are shown in Figure 2. The preliminary system utilized an ERV core (1) incorporated on the return side of a low-capacity, ducted, heat pump AHU. The device used negative pressure in the return plenum (2) to draw outdoor air in through the energy recovery core. A separate, variable-speed exhaust fan (5) diverted indoor air from the return air stream and drew this extract air through the other side of the ERV core. A modulating return air damper (3) and outdoor air damper (4) adjusted to maintain desired outdoor airflow rates, and the exhaust fan was controlled separately to maintain exhaust flow rates. Methods for measuring and controlling these flow rates are presented in the following section.

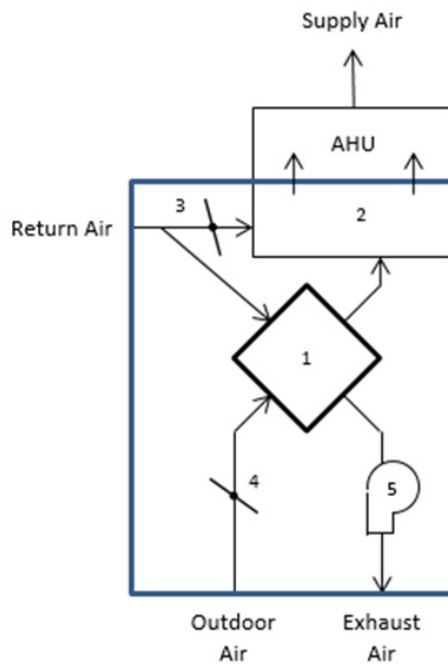

Figure 1. Schematic of VICS layout



Figure 2. Initial VICS prototype

## 2.2 Phase I Objectives

The overall performance goals for Phase I testing of the alpha prototype are in Table 1. Outcomes for each objective are noted briefly; see the results section for more information.

Table 1. Performance Goals for Phase I Alpha Prototype

| Parameter                    | Objective   | Met?                              |
|------------------------------|---|-----------------------------------|
| Maximum Ventilation Rates    | 120 cfm outdoor air; 120 cfm exhaust air  | Yes                               |
| Minimum Ventilation Rates    | 30–40 cfm outdoor air; 30–40 cfm exhaust air  | Yes (40 cfm)                      |
| Control of Ventilation Rates | Ability to control each rate distinctly between min/max to within 10 cfm; ability to reach set point flow rates within 10 minutes | Yes                               |
| Power Consumption            | No more than 70 W during ventilation only operation, 30 W or less additional power during heating/cooling operation               | Yes; with caveats—see Section 2.4 |
| AHU Pressure Settings        | Operate VICS with AHU on standard 0.5-in. water gauge (w.g.) setting (0.8-in. w.g. setting is available)                          | Not always; see Section 2.4       |
| Outdoor Air Ducts            | Provide design flows with up to 200 ft equivalent length of exhaust and outdoor air duct  | Yes; with caveats—see Section 2.4 |
| Return Air Filtration        | Ability to deliver target ventilation rates with a range of return air filters (pleated, non-MERV filter to MERV 13 filter)       | Yes                               |
| Supply Ductwork              | Ability to deliver target flow rates with a range of duct friction (400 cfm at 0.1 in. w.g. and 0.3 in. w.g.)                     | Yes; with caveats—see Section 2.4 |

### 2.3 Phase I Test Procedures

Phase I focused on pressures, flow rates, and power consumption. Temperature and humidity measurements were not taken at this time because validation of the negative suction pressure approach was the primary focus. The key goal was to determine if the design approach was feasible or if an alternative approach needed consideration. Figure 3 provides a more detailed two-dimensional schematic of the first VICS prototype, with locations of pressure sensors noted by red dots and flow stations labeled “flow.” To simulate various duct configurations, SWA installed iris dampers in the outdoor air intake duct, exhaust duct, and supply trunk to allow for additional restrictions to be applied to the system for testing purposes.

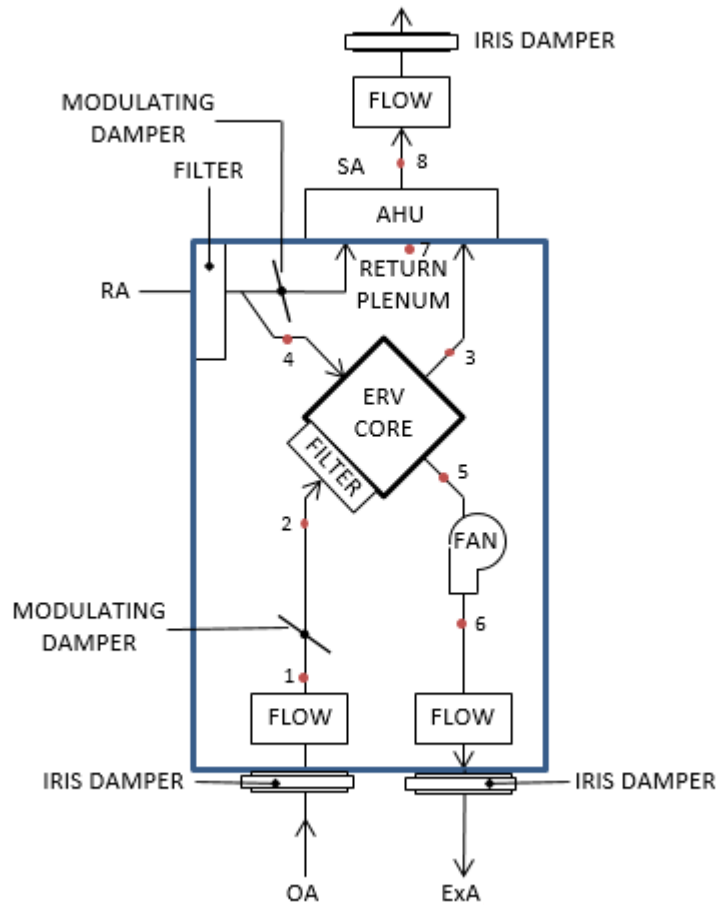

Figure 3. Schematic of the first VICS prototype with sensor locations highlighted

Key static pressure measurements for Phase 1 testing are listed below. Numbers refer to locations in the Figure 3 schematic.

1. Outdoor air static pressure before modulating damper (in. w.g.)
2. Outdoor air static pressure after modulating damper (in. w.g.)
3. Tempered outdoor air static pressure after core (in. w.g.)
4. Return exhaust air static pressure before core (in. w.g.)
5. Exhaust air static pressure before exhaust fan (in. w.g.)
6. Exhaust air static pressure after exhaust fan (in. w.g.)
7. Air handler return plenum static pressure (in. w.g.)
8. Air handler supply plenum static pressure (in. w.g.)

Airflow and power measurements included:

- Air handler supply airflow rate (cfm)
- Outdoor air airflow rate (cfm)
- Exhaust air airflow rate (cfm)
- Power measurements for the AHU (W)
- Power measurements for the VICS exhaust fan (W).

Testing and instrumentation methods were very similar for all phases and are detailed in Appendix A. Calculations methods are described in Appendix B. To measure static pressures, researchers used Dwyer A-302 pressure probes with Setra pressure transducers (model 2641-0R5WD-11-T1-F). Outdoor air and exhaust flow rates were measured with pitot traverse stations (Air Monitor LO-Flo 6") with Setra pressure transducers (2641-0R1WD-11-T1-F). The same pressure transducer was used to measure supply flow rates coupled with a Kele FXP-12 measuring station. Power measurements were made with CCS WattNode WNC-3D-240-MB transducers coupled with 5-amp current transducers. All instruments were connected to a P2000 Programmable Logic Controller from Automation Direct; this programmable logic controller was also used to send control signals. All flow stations were checked using a Duct Blaster from the Energy Conservatory. Measured flow rates agreed within listed instrument accuracies.

SWA performed parametric tests on the prototype with combinations of the following variables. These tests were done entirely in SWA's office workshop; outdoor air and exhaust ducts were not run to the outdoors for these initial tests.

- Ventilation airflow rate set points: 40 cfm/70 cfm/120 cfm
- Air handler fan speed setting: low/high
- Supply duct resistance (iris damper): 0.1 in. w.g./0.3 in. w.g. at 400 cfm

- Outdoor and exhaust duct resistance (iris dampers): 0.08 in. w.g./0.15 in. w.g./0.24 in. w.g. at 120 cfm
- Return air filters: MERV 7/MERV 12.

At each combination of conditions, the programmable logic controller used a proportional-integral function to maintain ventilation flow set points by varying damper positions and exhaust fan speed. Airflow, static pressure, and power measurements were recorded for each set of conditions.

## 2.4 Phase I Test Results

In the end, the first prototype was able to meet ventilation flow set points under all of the conditions tested. With higher duct restrictions and at higher ventilation flow rates, however, the static pressure setting of the AHU needed to be increased (from the 0.5 in. w.g. default setting to 0.8 in. w.g.) to meet outdoor airflow set points. Table 2 shows results from four tests with ventilation flow rate set point at 120 cfm. The third row shows that the 120 cfm outdoor air set point was not achieved under the most restrictive configuration for outdoor and supply air ductwork. When the AHU setting was changed from 0.5 in. w.g. to 0.8 in. w.g. (fourth row), the outdoor airflow rate was achieved without difficulty. As expected, this higher static pressure setting results in significantly higher power consumption.

**Table 2. Summary of Test Results with 120 cfm Outdoor Air Set Point and AHU Flow Rate Set to “Low”**

| AHU Static Pressure Setting [in. w.g.] | OA Damper Pressure Drop @ 120 cfm [in. w.g.] | Equivalent Duct Length (Based on Damper Pressure Drop) | Supply Damper Pressure Drop @ 400 cfm [in. w.g.] | Outdoor Airflow [cfm] | Exhaust Airflow [cfm] | Supply Airflow [cfm] | Total Power [watts] |
|--|--|--|--|-----------------------|-----------------------|----------------------|---------------------|
| 0.5                                    | 0.08   | 66 ft  | 0.10   | 121                   | 116                   | 240                  | 37                  |
| 0.5                                    | 0.15   | 125 ft   | 0.15   | 118                   | 112                   | 228                  | 37                  |
| 0.5                                    | 0.24   | 200 ft   | 0.30   | 85                    | 88                    | 215                  | 34                  |
| 0.8                                    | 0.24   | 200 ft   | 0.30   | 121                   | 121                   | 228                  | 55                  |

The tests also showed that closing the modulating return air damper (to increase outdoor airflow rate) resulted in lower airflow rates through the AHU. Although this was expected to a degree, the impact was much more pronounced than initial calculations suggested. Figure 4 shows the impact on total airflow through the air handler (orange line: AHU supply air [SA] flow) and outdoor air (blue line: outdoor air [OA] flow) as the return air damper (gray line) is stepped closed from 0% (open) to 100% (closed). Up to a 40% return air damper closure, there was no noticeable impact to the AHU flow rate. When the return air damper was closed more than 60%, there was a dramatic drop-off in AHU flow (<300 cfm/ton) that would impact the effectiveness of heating and cooling. As noted in Table 2, a higher AHU static pressure setting can alleviate this issue, but this was a manual adjustment and not something that can automatically change

based on damper closure. Therefore, to be able to meet the upper ventilation flow range, the AHU would need to always be running at the 0.8 in. w.g. setting, which would result in the total system electrical consumption being higher than desired.

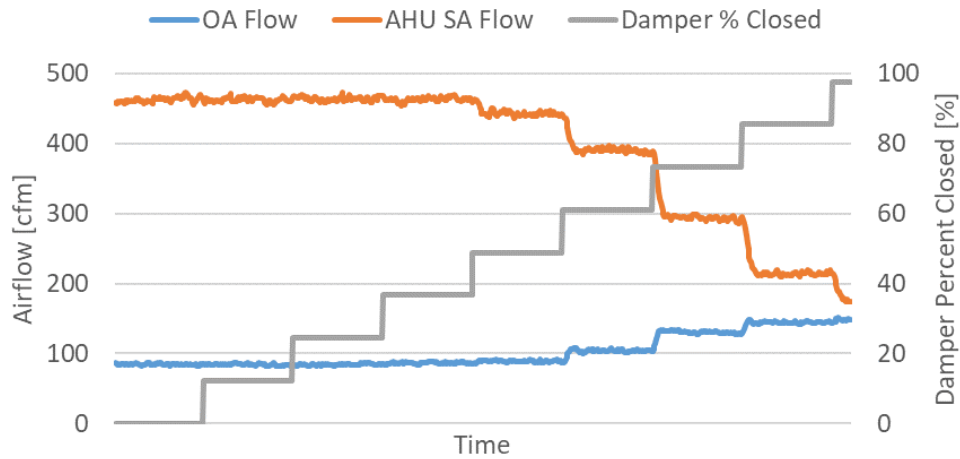

Figure 4. Impact of modulating return air damper on total AHU flow and outdoor airflow

## 2.5 Phase I Summary

As Table 1 shows, the initial prototype was able to maintain ventilation flow rates within 5–10 cfm under varying heating and cooling operations and air handler fan speeds. The power consumption of the total system in ventilation-only mode was less than the 70-W target for most test conditions. At high ventilation flow rates and with more restrictive duct systems, the prototype was not always able to deliver 120 cfm with the standard AHU static pressure setting. At the higher static pressure settings, desired flow rates were delivered but power consumption was higher than the 70-W target. As described in the following section, the prototype had other problems at higher ventilation flow rates that impacted performance of the heat pump. This necessitated an adjustment to the design.



## 3 Phase II: Ventilation Prototype with Heat Pump

The key focus of Phase II testing was to determine interaction and impacts between the VICS alpha prototype (designed and built during Phase I) and the heating and cooling system. With this alpha prototype, there was potential for lower AHU flow rates caused by the return damper (which closed to draw in more outdoor air through the core). There was also potential, however, for efficiency improvements because of slightly warmer air (in summer) or cooler air (in winter) moving across the heat pump coil. The team needed to determine whether this design approach was viable and if modifications could be implemented to minimize any negative impacts. In addition, Phase II testing assessed achievement of heat recovery effectiveness goals (at least 70% sensible, 50% total at 120 cfm) and power consumption (50 W or less for both AHU and VICS at 120 cfm).

### 3.1 Winter Testing

#### 3.1.1 Heat Pump Performance

Testing of the heat pump was first done without the VICS to establish a baseline; connections to the ventilation system were entirely sealed so the heat pump was operating in a stand-alone configuration. There is no published data for the Mitsubishi system tested because it consisted of an outdoor unit (FH12) rated for ductless systems and an indoor unit (MVZ12) used for multisplit applications. The system's performance was quite similar to manufacturer capacities and power consumption listed for the ductless FH12 heat pump. Some representative performance values are shown in Table 3.

Table 3. Heat Pump Representative Performance Values

| Mode    | Outdoor Dry Bulb | Total Output | COP |
|---------|------------------|--------------|-----|
| Heating | 15°F             | 13,000 Btu/h | 2.4 |
| Heating | 43°F             | 3,000 Btu/h  | 4.1 |
| Cooling | 75°F             | 5,000 Btu/h  | 5.5 |
| Cooling | 90°F             | 10,000 Btu/h | 3.0 |

When VICS testing began, one of the team's concerns—that restricting return airflow could negatively affect heat pump performance—was immediately identified as a major problem during heating season testing. Figure 5 shows that at ventilation rates above 70 cfm, the coefficient of performance (COP) of the heat pump dropped off by ~25%. It is unclear why the COP without any ventilation is lower than with 40 or 70 cfm of ventilation. Measurement uncertainty (note 95% error bars), lower air temperature entering the coil with ventilation, and variations in compressor speed may all contribute. Outdoor air temperatures were 35°–36°F for all tests, and heating output was between 4,100 and 5,200 Btu/h.

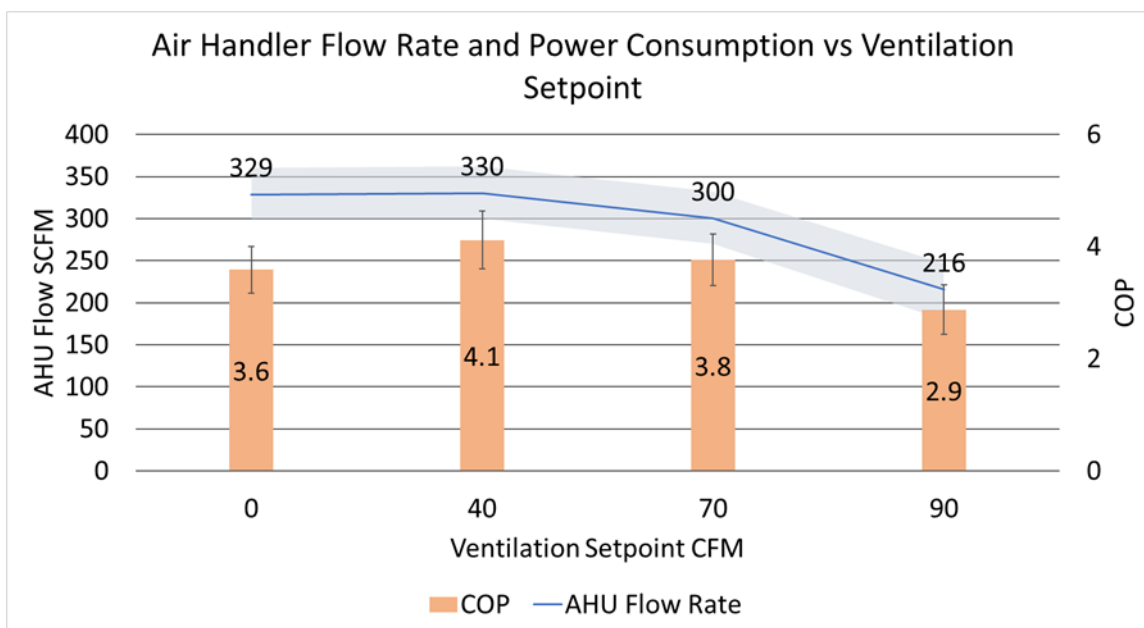

Figure 5. Impact of ventilation set point on AHU flow rates and COP during winter testing

Obviously, this was an unacceptable result. The team considered whether to limit the ventilation range of the VICS to no more than 70 cfm, but this would limit the versatility of the design and would likely inhibit any future smart controls to enable building pressure neutralization (in which the system goes unbalanced to counter local exhaust ventilation that might be occurring in the dwelling).

In the end, the team determined that a redesign of the VICS was required, and the new design included a variable-speed, outdoor air supply fan. The key concern with adding a supply fan was increased power consumption. Based on the power consumption of the exhaust fan in the prototype, SWA gauged that the overall power increase from adding a supply fan would be no more than 15 W. There was also some concern about added equipment size/footprint with an additional blower, but the system dimensions were largely set by the ERV core and exhaust blower. An outdoor air supply fan was added between winter and summer testing; see Section 3.2 for a description of this.

### 3.1.2 Winter ERV Performance

Although the heat pump performance results required a redesign, the ERV core operated as expected. Overall, heating season ERV effectiveness values were in-line with the 73% sensible effectiveness stated in the CORE Energy Recovery Solutions literature. As expected, effectiveness values dropped with higher flow rates (see Table 4 and Figure 6). Sensible effectiveness in the winter ranged from above 80% (at 40 cfm) down to 65%–70% (at 120 cfm). Ventilation flow rates had a larger impact on core performance than temperature variations (Figure 7).

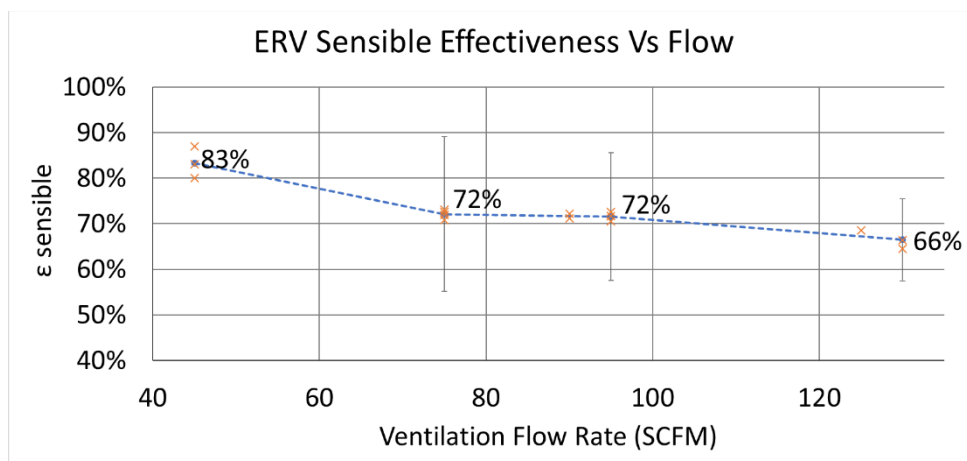

Figure 6. Sensible effectiveness ( $\epsilon$ ) values at various flow rates; flow is expressed in standardized cubic feet per minute (scfm)

The VICS achieved the sensible effectiveness design goal during most winter testing. At flow rates up to 70 cfm, the VICS exceeded this goal. At 120 cfm, sensible effectiveness values decreased to 65%–68%. It is worth noting that the later prototypes in this effort used CORE’s new “Mustang” core, which provided higher recovery effectiveness.

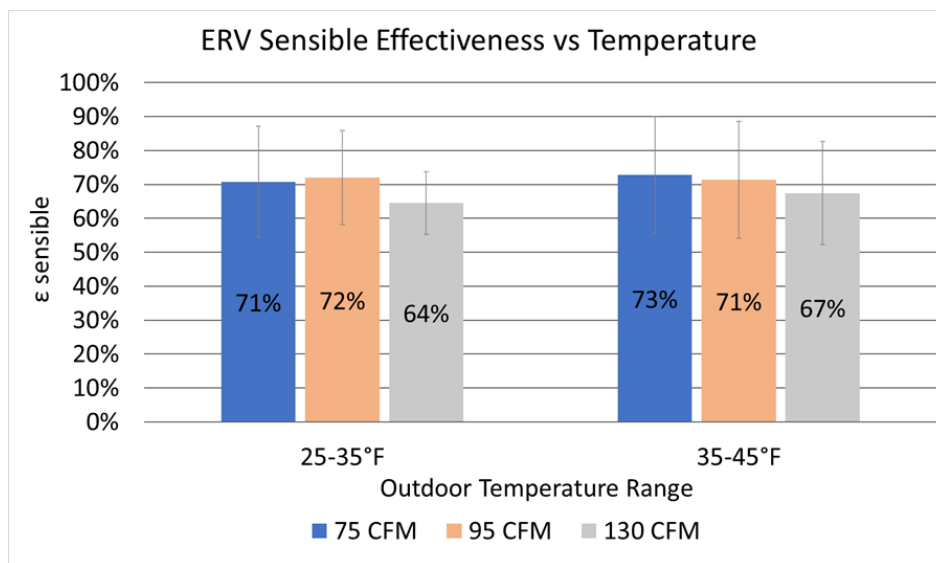

Figure 7. Sensible effectiveness at different temperatures and flow rates

The tests shown in Figure 6 and Figure 7 were conducted with outdoor temperatures ranging from 20°F to 35°F (unfortunately there were no extremely cold conditions in Connecticut during this test period). On average, temperature of the mixed air (entering the AHU) was approximately 1°F lower than return air at higher ventilation flow rates. When in ventilation-only mode (i.e., heat pump not operating), the supply air temperature was slightly above the mixed air temperature (from fan energy) and was quite close to return air temperature. Although blowing room-temperature air on occupants in cold weather can cause comfort concerns, this can be mitigated with good design. One guideline for this issue comes from Passive House standards

(PHIUS 2015). These require that ventilation air be delivered at no lower than 62°F, and this should be the case in normal operation. The VICS will normally operate in low fan speed unless the heating (or cooling) is engaged, so air velocities should be modest. For these reasons, the team determined that comfort concerns were small with the system, though good design is certainly important.

The team also hoped to assess potential for increased heat pump efficiency and capacity by passing slightly cooler air over the heat pump coil. With only a 1°F drop in temperature, however, capacity and/or efficiency improvements were too subtle to measure (if present at all).

### 3.1.3 Power Consumption

Under most conditions, the VICS used less than 50 W in ventilation-only mode (including AHU power). As discussed previously, to achieve 120 cfm of outdoor air consistently, the AHU needed to operate in high-static mode (0.8 in. w.g.). As Figure 8 shows, this resulted in higher power consumption when delivering 120 cfm. The exhaust fan in the VICS itself consumed 3–17 W depending on the ventilation set point and AHU conditions (this modest power consumption alleviated the concerns about adding an outdoor air supply fan). When the heat pump is operating in heating mode, this 3–17 W is basically the incremental power needed to provide ventilation.

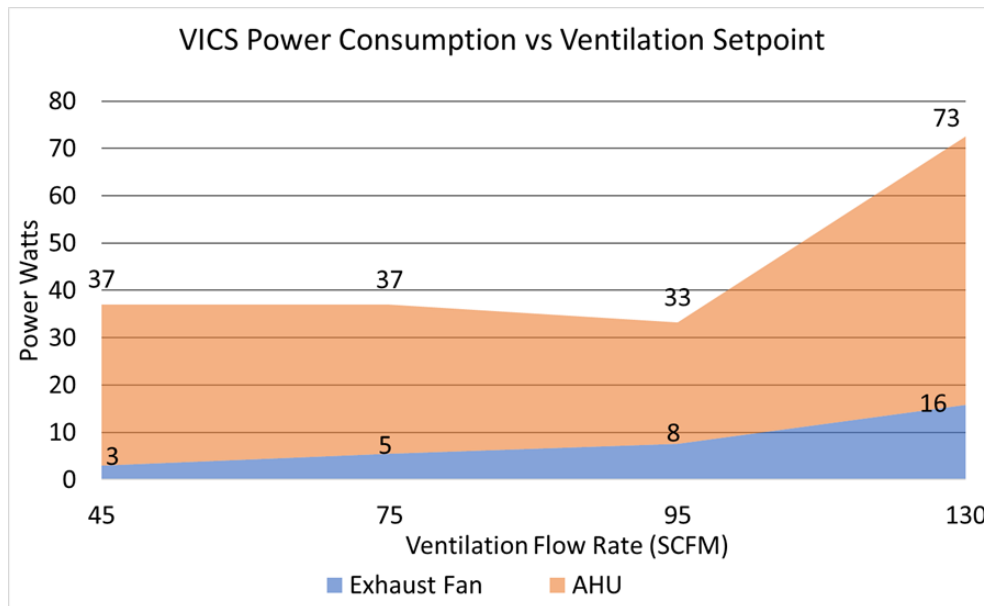

Figure 8. VICS power consumption at various flow rates

Although more than 90 configurations were tested during the course of this research, Table 4 shows selected, steady-state winter tests that represent the range in conditions and performance.

**Table 4. Selected Phase II Testing Conditions and Results**

| Flow<br>scfm | Outdoor Air |      | Return Air |      | Sensible  | Ex Fan | AHU   | Total |
|--------------|-------------|------|------------|------|-----------|--------|-------|-------|
|              | °F          | % RH | °F         | % RH | Eff.      | watts  | watts | watts |
| 43           | 38          | 69%  | 68         | 22%  | 80% ± 32% | 3.1    | 31.7  | 34.8  |
| 43           | 38          | 65%  | 68         | 22%  | 84% ± 34% | 3.1    | 31.7  | 34.8  |
| 43           | 44          | 44%  | 69         | 19%  | 88% ± 36% | 2.7    | 38.9  | 41.6  |
| 77           | 28          | 34%  | 68         | 18%  | 70% ± 16% | 5.8    | 31.8  | 37.6  |
| 75           | 38          | 65%  | 68         | 21%  | 72% ± 18% | 5.5    | 30.0  | 35.5  |
| 75           | 38          | 66%  | 68         | 22%  | 74% ± 18% | 5.5    | 30.1  | 35.6  |
| 75           | 43          | 48%  | 71         | 18%  | 72% ± 18% | 5.1    | 33.9  | 39.0  |
| 91           | 30          | 53%  | 61         | 15%  | 72% ± 14% | 6.9    | 25.3  | 32.2  |
| 96           | 38          | 62%  | 69         | 21%  | 70% ± 14% | 8.0    | 25.5  | 33.5  |
| 97           | 38          | 65%  | 67         | 22%  | 72% ± 14% | 8.2    | 26.1  | 34.3  |
| 127          | 35          | 49%  | 71         | 14%  | 64% ± 10% | 14.8   | 91.6  | 106.4 |
| 131          | 38          | 53%  | 70         | 17%  | 68% ± 10% | 15.8   | 59.2  | 75.0  |
| 130          | 46          | 48%  | 68         | 22%  | 66% ± 10% | 16.6   | 54.4  | 71.0  |

### 3.1.4 Frost Protection

The optimal method to manage or prevent frost in the core was uncertain at this point in the R&D process. The team considered preheating incoming air with electric resistance (energy intensive), recirculation or exhaust only (not desirable for indoor air quality reasons and not allowed in some programs), and partial bypass (where some outdoor air is ducted around the core to prevent frost forming). Bypass methods were tested in some detail in this phase, and—while moderately successful—SWA focused on a frost-prevention method suggested by Therma-Stor.

Therma-Stor suggested mixing warm indoor air into the outdoor air stream so that air passing through the core is not cold enough to cause frost (approximately 20°–25°F). This is somewhat similar to tempering outdoor air with resistance, but the tempering would be provided by the home heating source (the heat pump in our configuration) and would be much less energy intensive. To test this, a modulating damper was used to introduce varying amounts of return air into the cold outdoor air stream. When using this method, the airflow through the outdoor pathway of the ERV core is higher than the exhaust pathway, but the overall amount of supply and exhaust can remain balanced. This arrangement has the added benefit of reducing concerns about cold supply air temperature when the heat pump is not operating (a large concern with partial bypass). Drawings of a revised prototype using the strategy are shown in Figure 9. The tempering damper modulated to maintain a minimum temperature entering the core (thereby preventing frost formation).

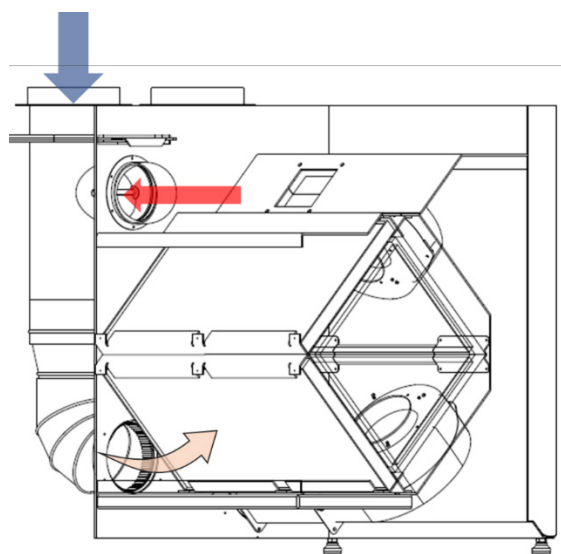

**Figure 9. Tempering frost prevention illustration: the tempering damper modulates, allowing warm return air (red arrow) to mix with outdoor air (blue arrow) before entering core (pink arrow)**

Although initial tempering tests highlighted needs for more thought on configuration, geometry, and control, the tempering approach showed great promise. In addition to the efficiency, comfort, and indoor air quality benefits highlighted previously, tempering will likely require less material, less space, and fewer components than the bypass strategy (which had been the most likely method at the start of this phase of testing). More details on the tempering frost prevention method can be found in Section 4.1.3.

### 3.2 Outdoor Air Supply Fan

Because the return damper negatively impacted the performance of the heat pump at higher ventilation rates, the research team considered two possibilities: lower the allowable ventilation range of the system or redesign to include an outdoor air fan. Because goals for the VICS include integration with a wide range of small-capacity systems, and because adding a supply fan would dramatically increase versatility, the choice was relatively simple. The availability of small, efficient, variable-speed fans made the decision even easier. Initial tests showed that power targets could be met (or very nearly met) even with the inclusion of a second blower.

After heating season testing, SWA assessed several blowers to draw outdoor air through the ERV core (one early configuration is shown in Figure 10). This fan reduced the dependence on AHU suction and negated the impact of the return air damper on heat pump COP. The addition of the auxiliary ventilation fan alleviated many of the prior issues with AHU flow rates. Another benefit of the outdoor air fan was more consistent outdoor air flow rates when the AHU changed speeds (for changing heating or cooling demands). Using the return air damper, the system took 1–2 minutes to equilibrate and deliver the desired outdoor air flow rate. With the outdoor air fan, flow rates stabilized within 30 seconds.

Even with the outdoor air blower added, the system still had the AHU blower running in low speed when in ventilation-only mode. Operation of the air handler is necessary to distribute the outdoor air through the supply ductwork and to prevent short-circuiting of fresh air.

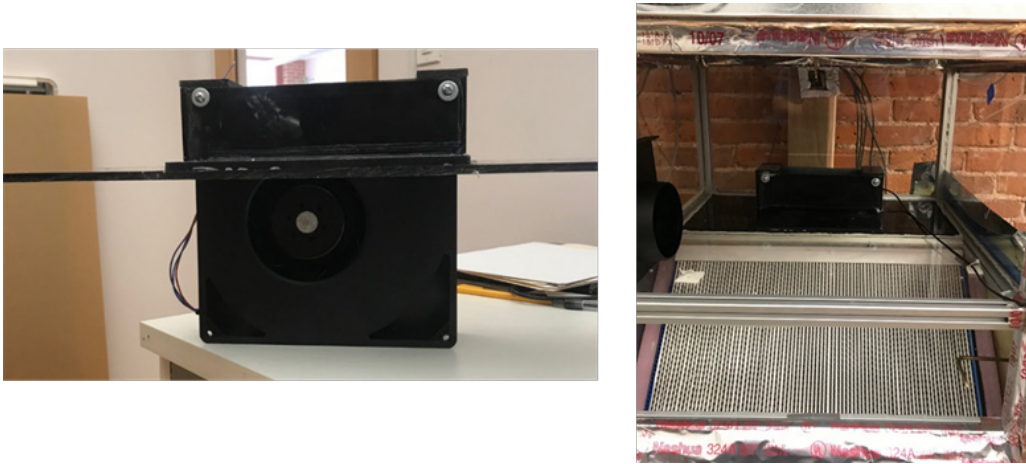

Figure 10. Retrofit intake fan

### 3.3 Summer Testing

Cooling tests were done throughout the summer of 2018 (June–August). The key goals of the summer testing were to document the effectiveness of the ERV (both sensible and total) during hot, humid weather; gauge the efficiency of the heat pump in cooling mode; and assess any impacts from the VICS on heat pump cooling capacity (especially latent) and efficiency.

#### 3.3.1 Heat Pump Performance

As in heating season, SWA was not able to keep the compressor speed constant. This made comparing different tests of steady state operation more challenging. Table 5 shows representative results of heat pump capacity and efficiency at different operating temperatures and at different cooling capacities. As expected, cooling COP values were higher at lower loads and at lower outdoor temperatures. This trend was extremely pronounced at lower loads; at higher loads the trend was less pronounced.

**Table 5. Representative Summer Testing Summary**

| Test No. | Outdoor Air |          | Mixed Air |     | Supply Air  |         |     | Heat Pump    |           |     |
|----------|-------------|----------|-----------|-----|-------------|---------|-----|--------------|-----------|-----|
|          | Flow [scfm] | DB* [°F] | DB [°F]   | RH  | Flow [scfm] | DB [°F] | RH  | Qtot [Btu/h] | Power [W] | COP |
| 91       | 40          | 75.0     | 71.8      | 65% | 285         | 58.1    | 99% | 5,162        | 269       | 5.6 |
| 16       | 114         | 86.1     | 75.0      | 49% | 304         | 60.7    | 81% | 4,496        | 369       | 4.0 |
| 94       | 50          | 90.3     | 69.7      | 63% | 302         | 57.2    | 96% | 4,127        | 374       | 3.3 |
| 90       | 39          | 75.6     | 69.0      | 64% | 294         | 51.2    | 95% | 8,724        | 736       | 3.5 |
| 36       | 117         | 85.0     | 74.9      | 60% | 409         | 60.3    | 96% | 7,262        | 669       | 3.4 |
| 95       | 73          | 90.7     | 71.3      | 56% | 409         | 55.5    | 94% | 7,740        | 731       | 3.2 |

\*DB = dry bulb

During heating season, the return damper compromised heat pump efficiency. When the system was redesigned and an outdoor air fan added, the flow reduction and efficiency liability were completely removed. It is possible that efficiency may even increase slightly at higher ventilation flow rates. The outdoor air fan results in slightly higher flow through the AHU at higher ventilation rates. Figure 13 shows an example of different ventilation flow rates with all other conditions fairly constant (85°–90°F outdoor DB, loads of approximately 4,500 Btu/h). Compared to the performance drop shown in Figure 7, the impact of including an outdoor air blower is very clear.

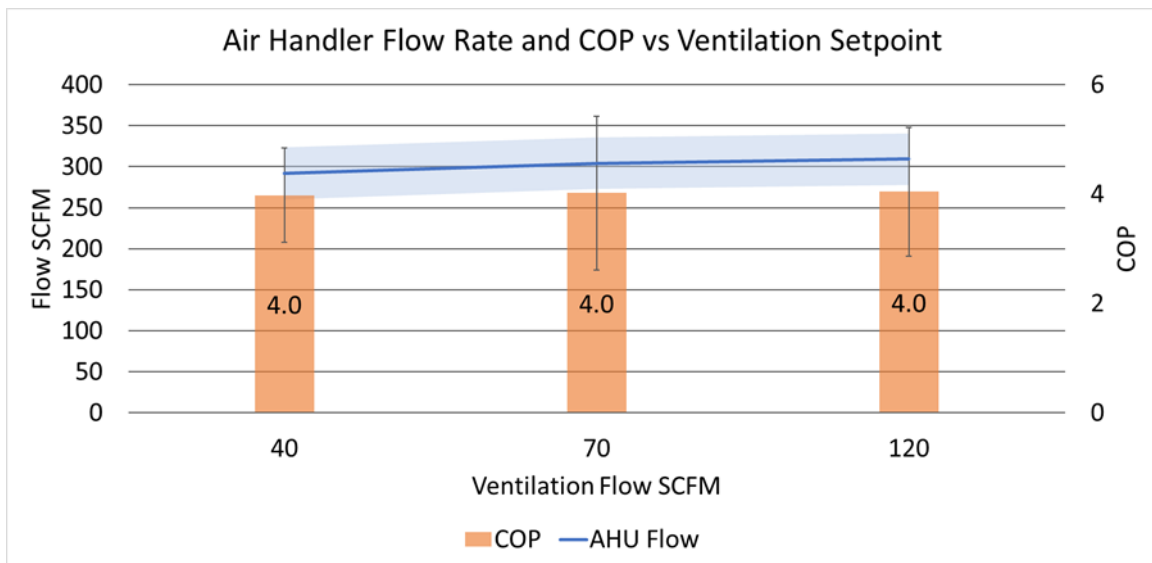

**Figure 11. Ventilation set point and heat pump COP. Outdoor temperature is 85°–90°F, and loads are 4,000–5,000 Btu/h. Higher ventilation rates appear to have no impact on the heat pump COP.**



### 3.3.2 Latent Cooling and Coil Drying

When the heat pump was operating at low speed (low fan speed, outdoor unit at approximately 300 W), latent removal was almost always quite low. SWA observed frequent periods, in fact, where the coil appeared to load and unload moisture almost cyclically (SHR bouncing slightly above and below 100%). There are significant uncertainties in these calculations, but regardless, at low speed latent removal was very low. This effect was more extreme at warmer outdoor temperatures. This may have larger implications on moisture removal of inverter-driven heat pumps in general, but it is a somewhat separate issue than the performance effects of the VICS.

The first three rows in Table 6 show runs with some latent capacity at different ventilation flow rates. The second group (tests 21, 24, and 25) shows more common results where there was virtually no latent removal. Especially at mild outdoor temperatures, COP seems to be dramatically affected by entering (mixed air) wet bulb. Introducing air from the ERV into the return air certainly increases wet bulb (especially during hot, humid weather), but the effect is modest. In these runs, variations in return air temperature dominate. These values also show more moisture was removed at higher ventilation rates, but uncertainties are substantial and other parameters vary.

**Table 6. Heat Pump Cooling Performance at Various Ventilation Rates**

| Flow | Outdoor Air |     |      | Return Air |     |      | Mixed Air |     |    | Heat Pump |       |                  |                  |      |     |
|------|-------------|-----|------|------------|-----|------|-----------|-----|----|-----------|-------|------------------|------------------|------|-----|
|      | DB          | RH  | WB   | DB         | RH  | WB   | DB        | RH  | WB | Flow      | Power | Q <sub>lat</sub> | Q <sub>tot</sub> | SHR* | COP |
| scfm | °F          | %   | °F   | °F         | %   | °F   | °F        | %   | °F | scfm      | watts | Btu/h            | Btu/h            |      |     |
| 40   | 75.0        | 90% | 73   | 71.8       | 62% | 63   | 71.8      | 65% | 64 | 285       | 269   | 959              | 5,162            | 81%  | 5.6 |
| 70   | 77.2        | 84% | 73   | 69.2       | 65% | 61   | 68.8      | 70% | 62 | 300       | 298   | 1,220            | 4,949            | 75%  | 5.1 |
| 124  | 76.7        | 88% | 73   | 73.8       | 63% | 65   | 73.9      | 68% | 66 | 308       | 319   | 1,462            | 5,575            | 74%  | 5.8 |
| 41   | 84.2        | 55% | 72   | 73.4       | 55% | 63   | 73.7      | 56% | 63 | 292       | 329   | -3               | 4,657            | 100% | 4.2 |
| 71   | 85.1        | 52% | 72   | 73.2       | 49% | 61   | 73.7      | 51% | 62 | 302       | 344   | -92              | 4,691            | 102% | 4.2 |
| 118  | 86.5        | 63% | 75   | 72.6       | 57% | 62   | 73.9      | 61% | 65 | 308       | 369   | 352              | 4,896            | 93%  | 4.3 |
| 73   | 90.7        | 45% | 73.8 | 70.6       | 54% | 60.1 | 71.3      | 56% | 61 | 409       | 731   | 772              | 7,740            | 90%  | 3.2 |
| 124  | 93.0        | 47% | 76.1 | 72.7       | 51% | 60.9 | 73.9      | 53% | 62 | 545       | 927   | 418              | 9,900            | 96%  | 3.1 |

\*SHR stands for sensible heat ratio.

Because the AHU runs continuously for ventilation, SWA was concerned about the potential for reintroducing moisture from a wet coil into the building when a cooling cycle ends. As Figure 12 shows, when a cooling cycle ends abruptly (shown when the orange line drops to near zero), nearly 0.5 lbm of water (400–500 Btu, represented by area beneath the gray line) could be reintroduced into the air stream over approximately 10 minutes. This is a concern, but is a common concern of all ERV/HRV units that use central AHU and ductwork for distribution. SWA had several discussions with Mitsubishi and Therma-Stor about this issue, but a solution is not clear. Turning off the fan for a period (perhaps 10–30 minutes) immediately after a cooling cycle ends could allow the coil to dry, but this would interrupt ventilation, or at least distribution of outdoor air.

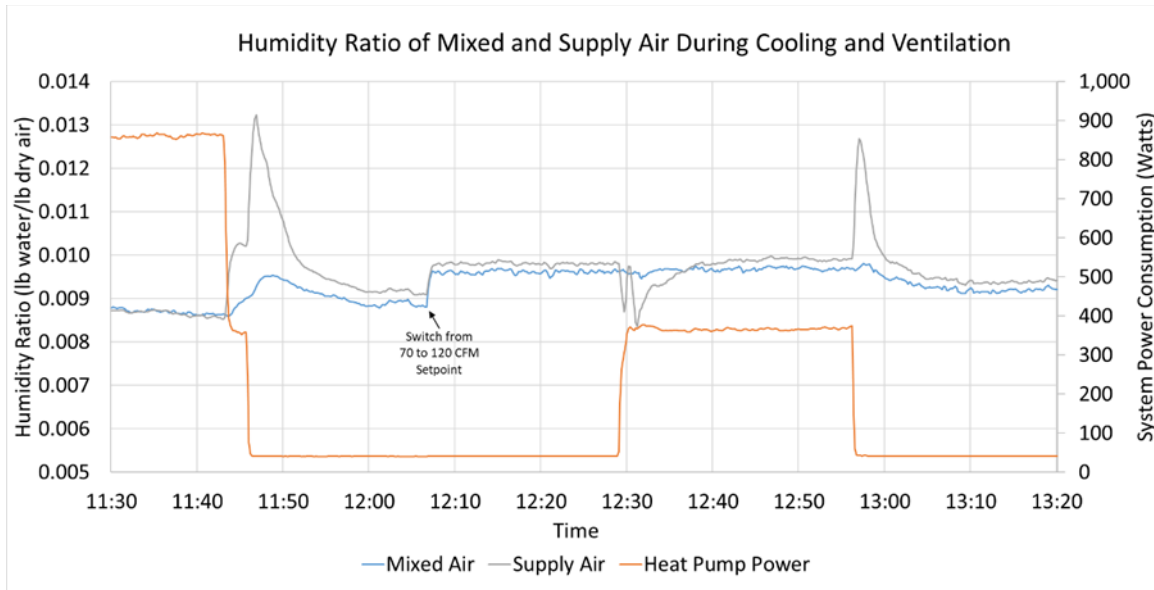

Figure 12. Humidity ratio during and after calls for cooling

### 3.3.3 ERV Performance

SWA installed a dehumidifier to keep the test room at 50%–60% relative humidity (RH) during many of the cooling tests. This provided a higher enthalpy differential between hot, humid outdoor air and indoor air. This higher differential resulted in higher heat transfer and lower relative uncertainties. As Table 7 and Figure 13 show, ERV effectiveness decreased with ventilation flow rates. There were not marked differences in effectiveness values at different outdoor conditions.

Table 7. Summer ERV Effectiveness at Various Flow Rates and Outdoor Conditions

| Test No. | Outdoor Air |         |     | Return  |     | Q <sub>ex</sub> [Btu/h] |       | Q <sub>OA</sub> [Btu/h] |       | Effectiveness |       |
|----------|-------------|---------|-----|---------|-----|-------------------------|-------|-------------------------|-------|---------------|-------|
|          | Flow [scfm] | DB [°F] | RH  | DB [°F] | RH  | Sens.                   | Total | Sens.                   | Total | Sens          | Total |
| 21       | 41          | 84      | 55% | 73      | 55% | 287                     | 766   | 319                     | 760   | 75%           | 59%   |
| 23       | 40          | 87      | 49% | 73      | 50% | 385                     | 920   | 403                     | 911   | 73%           | 59%   |
| 22       | 38          | 87      | 46% | 77      | 52% | 248                     | 504   | 268                     | 487   | 73%           | 59%   |
| 97       | 36          | 91      | 56% | 77      | 51% | 339                     | 1,124 | 395                     | 1,248 | 80%           | 65%   |
| 18       | 68          | 79      | 66% | 74      | 49% | 219                     | 1,044 | 255                     | 1,270 | 73%           | 58%   |
| 24       | 71          | 85      | 52% | 73      | 49% | 558                     | 1,406 | 562                     | 1,351 | 68%           | 52%   |
| 15       | 70          | 87      | 41% | 74      | 46% | 576                     | 1,044 | 579                     | 909   | 69%           | 51%   |
| 98       | 71          | 92      | 50% | 73      | 56% | 863                     | 1,939 | 857                     | 1,790 | 68%           | 51%   |
| 19       | 120         | 81      | 64% | 75      | 45% | 358                     | 1,684 | 422                     | 1,952 | 68%           | 47%   |
| 20       | 120         | 83      | 57% | 74      | 51% | 659                     | 1,808 | 660                     | 1,734 | 62%           | 44%   |
| 17       | 118         | 86      | 43% | 76      | 47% | 671                     | 1,157 | 692                     | 1,023 | 63%           | 44%   |
| 96       | 124         | 93      | 47% | 73      | 51% | 1,530                   | 3,090 | 1,440                   | 2,698 | 61%           | 43%   |

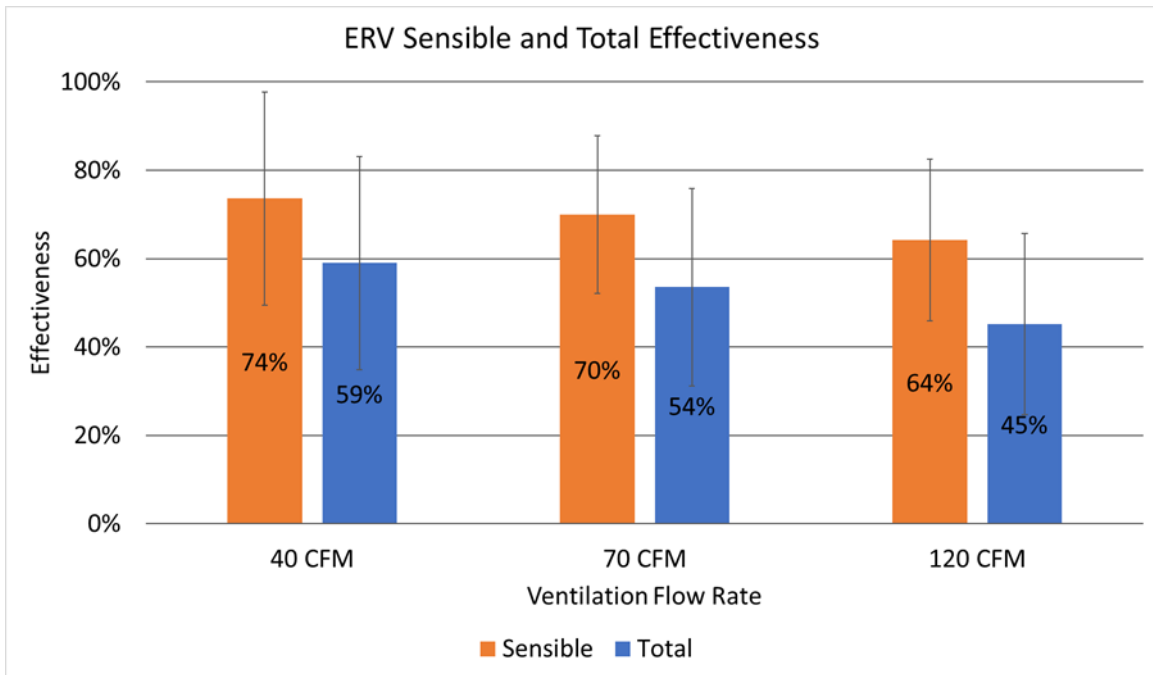

Figure 13. Average ERV effectiveness at different flow rates from Table 7

Measured sensible and latent effectiveness values were similar to the CORE specifications (well within the calculated uncertainty).

### 3.3.4 Power Consumption

The use of an intake fan approximately doubled the power consumption of the VICS. SWA used two variable-speed axial fans for cooling tests. The ventilation fans consumed about 37 W at 120 cfm (Figure 14). This, combined with the consistent 36–38 W used by the AHU in low speed, results in a total power consumption of 74 W at 120 cfm. This is somewhat higher than initial goals, but additional fans have since been evaluated that use less power.

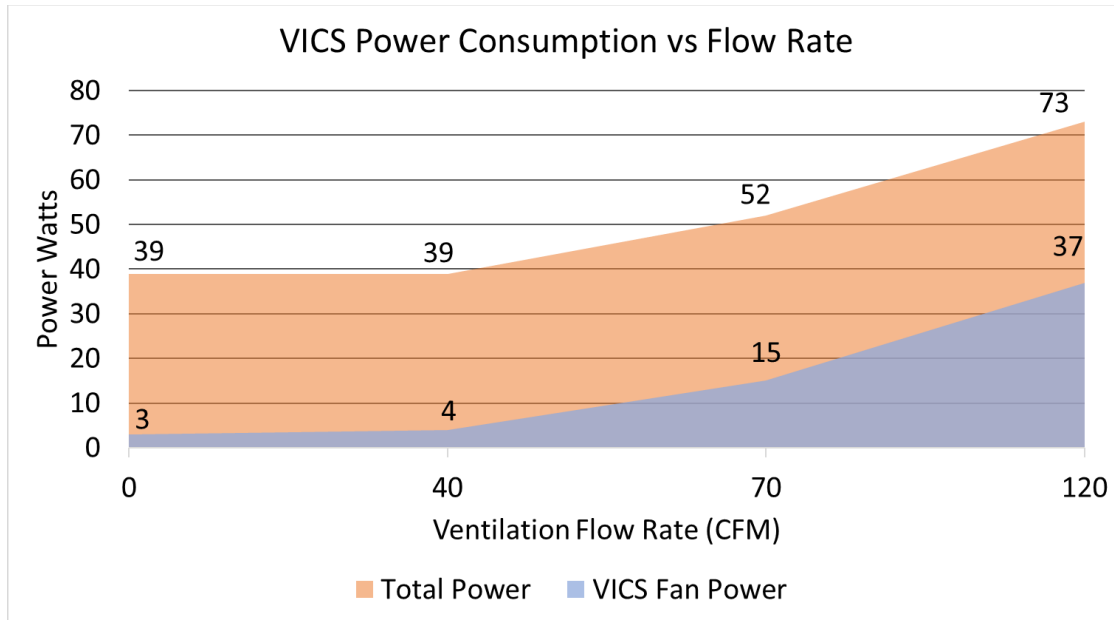

Figure 14. VICS power consumption with use of retrofitted intake fan

### 3.4 VICS and Heat Pump Interactions: Heating

An overwhelming conclusion from heating season testing was that the return air damper has a substantial negative impact on heat pump efficiency. This was clear to all, and SWA reconfigured the system for cooling season tests. After an outdoor air fan was added, there was no reduction in AHU flow rate at higher ventilation rates (there was actually a slight increase in AHU flow rates at higher ventilation rates). This problem was completely addressed by the redesign.

A much more subtle impact is the change of air properties entering the heat pump coil. In winter, introducing outdoor air (even tempered outdoor air) into the return air stream will lower the temperature of air entering the coil. This has the potential to increase heat pump capacity and efficiency. Mitsubishi literature shows the impact of entering air temperature on capacity and efficiency (Figure 15). Note that data represented in Figure 15 are for an FH12, which is a ductless heat pump. The system tested with the VICS combined the FH12 outdoor unit with a ducted (MVZ12) air handler. These data are also for steady-state operation at the rated compressor speed; it is not clear how these trends would change as the heat pump modulates. Nevertheless, entering air temperature clearly has significant impact on heat pump performance, especially COP.

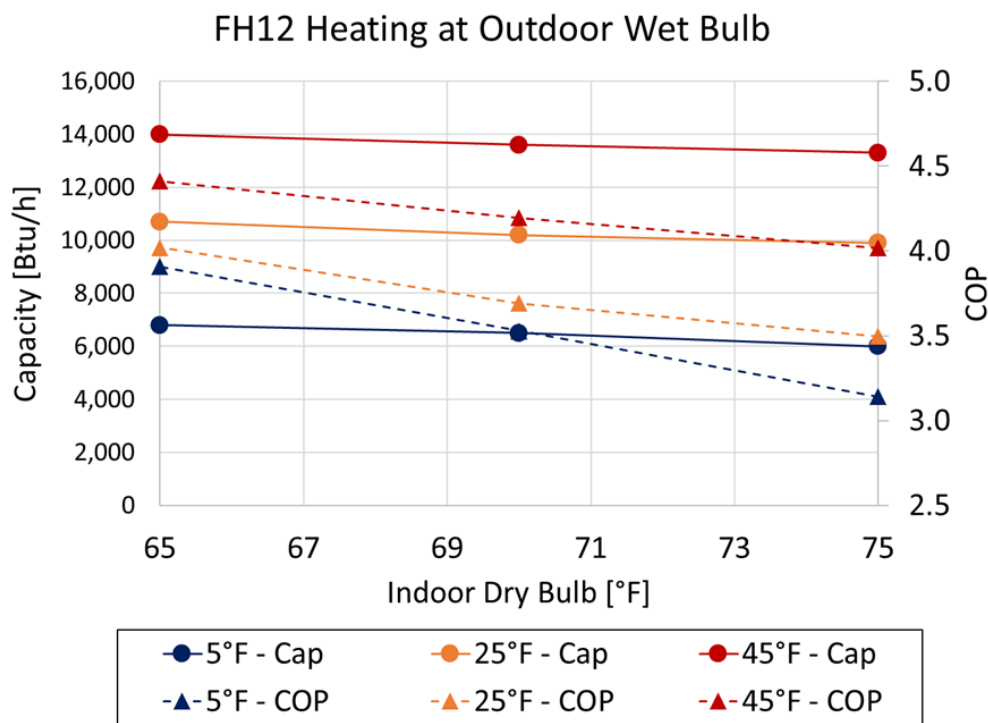

Figure 15. Heating capacity and COP vs. return air temperature

SWA did not measure dramatic drops in mixed air temperature (i.e., mixture of return and tempered outdoor air), but this was partly because there was no very cold weather during the test period. Mixed air temperature is easy to calculate, however, and at very cold outdoor temperatures (5°F) and high flow rates (120 cfm), mixed air will be approximately 8°F colder than return air. If slopes from the COP curves in Figure 15 are applied to expected mixed air temperatures, the potential increase in COP is outlined in Table 8.

Table 8. Potential for Increased COP from Manufacturer Literature

| Outdoor Wet Bulb | COP Increase at Ventilation Rates |        |         |
|------------------|-----------------------------------|--------|---------|
|                  | 40 cfm                            | 70 cfm | 120 cfm |
| 5°F              | 0.1                               | 0.3    | 0.6     |
| 25°F             | 0.0                               | 0.1    | 0.3     |
| 45°F             | 0.0                               | 0.1    | 0.1     |

This is only an academic exercise at this point. The real effect was too subtle to measure in SWA’s tests (at mild temperatures), and there are substantial assumptions. Nevertheless, there is potential for a meaningful increase in COP at—and only at—higher ventilation rates and lower outdoor temperatures. Compared to an identical home with a conventional ERV (not integrated with the heating/cooling), the overall heating load of a home with a VICS would be the same. However, during extremely cold temperatures and high ventilation rates, a heat pump in the VICS home may consume considerably less electricity.

If the heat pump is not operating, the cool air delivered to the living space has the potential to be a comfort liability. This is not unique to the VICS; this concern applies to many ventilation systems. As tempered outdoor air will mix with return air before being delivered, the air delivered by the VICS will be warmer than with a stand-alone ERV. Air velocities will be higher, however, and this can increase comfort problems. As discussed in Section 3.1.2, supply air was approximately 1°F lower than return air temperature during cold weather without the heat pump operating. At extremely cold outdoor temperatures, however, when supply air could be the coldest, it's very likely that the heat pump will be operating. At this stage, SWA believes that comfort concerns are quite modest and can be minimized by good design—as with any HVAC system.

### 3.5 VICS and Heat Pump Interactions: Cooling

As with heating performance, Mitsubishi literature shows similar impacts of entering wet-bulb temperature on heat pump capacity and efficiency (Figure 16). During cooling, however, the most dramatic impacts are on latent capacity; COP changes very little. The same caveats apply when trying to apply these trends to the tested VICS system: these data are from a ductless heat pump at fixed (relatively high) compressor speed.

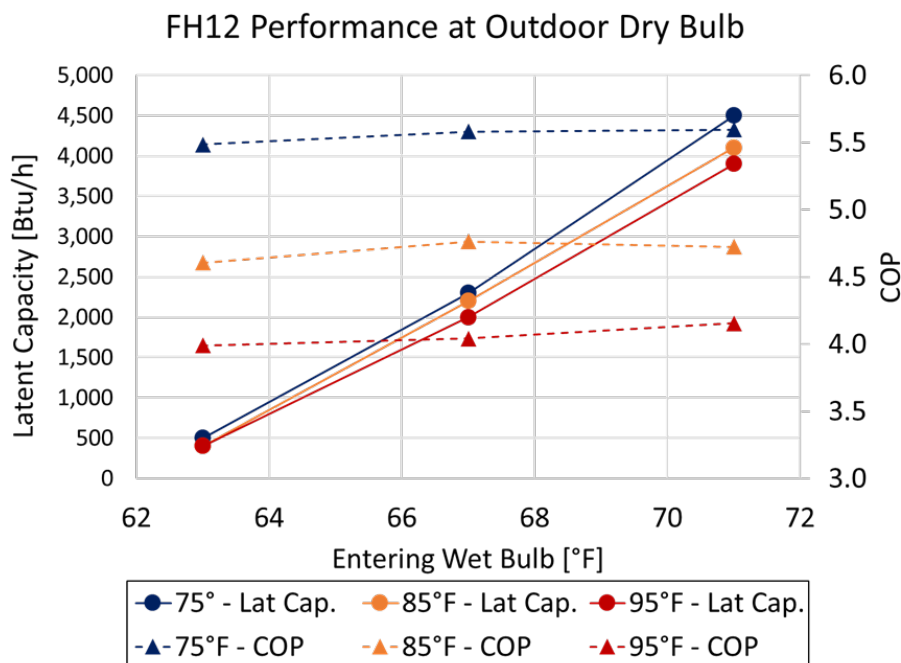

Figure 16. Impact of entering wet-bulb temperature on capacity and efficiency

SWA consistently saw increased mixed-air wet bulbs on the order of 0.5°F at 40 cfm, 1°F at 70 cfm, and 2°F at 120 cfm. The slopes of the curves in Figure 16 imply an increase in latent capacity of 400–500 Btu/h for each 1°F wet-bulb increase. Practically, however, SWA saw much lower latent capacities in tests. It was only at high compressor speeds that SWA saw significant latent capacities. During most tests, total cooling capacity was 4,000–6,000 Btu/h, and sensible heat ratio was usually close to 1.0. With current controls, this inverter heat pump will not provide

significant latent removal under most operating conditions. It is only at high speeds and high loads that there is likely to be much moisture removed. This may be a concern for inverter heat pumps in general, and SWA has had several conversations with Therma-Stor and Mitsubishi on this topic. Therma-Stor is currently developing an inverter heat pump with much greater latent cooling potential that could address this concern nicely.

Another moisture concern occurs at the end of a cooling cycle when the heat pump turns off completely. SWA found nearly 0.5 lbm of water could be introduced back into the space when the AC turns off. This concern is applicable to any ventilation system that uses the central AHU and ductwork for distribution of whole-house ventilation. One control solution to this problem is to turn off ventilation completely for 15–20 minutes when a cooling cycle ends (to allow the coil to drain). Intermittent ventilation is not ideal, and discussions with Therma-Stor and Mitsubishi about this topic are ongoing.

### 3.6 Phase II Summary

In Phase II, the ERV prototype was integrated with an operating heat pump. The tests validated the overall approach with one major caveat: an outdoor air supply fan was necessary to maintain flow rate through the AHU and coil. Most of the performance criteria for this prototype were met, including:

- Power consumption of 75 W or lower at 120 cfm (initial target was 70 W before outdoor air blower was included)
- Sensible recovery effectiveness of 65%–70% at 120 cfm (matching literature from the core manufacturer)
- Total recovery effectiveness of 45% at 120 cfm (matching literature from the core manufacturer)
- Ventilation flow rates are maintained regardless of heating/cooling operation.
- No negative impacts on heating performance. There is potential for heating efficiency boosts at low temperatures and high ventilation rates.

No negative impacts during cooling operation. However, continuous airflow may reintroduce moisture into the air at the end of a cooling cycle.

## 4 Phase III: Beta Prototype and Testing

### 4.1 Beta Prototype Design Considerations

During Phase I, researchers designed and tested an alpha prototype that used static pressure from the AHU to draw in outdoor air. In Phase II, this alpha prototype (with modest adjustments) was connected to outdoor air and to a fully functioning heat pump system. Phase II tests highlighted some key limitations of the design. In Phase III, the design for a beta prototype addressed these issues:

- Fans and flow control goals and limitations
- ERV core selection and sizing
- Frost prevention
- Overall geometry, size, and accessibility.

#### 4.1.1 Fans and Flow Control

In very early stages—even before the research effort began—one of the factors that made the VICS seem appealing and practical was the increased availability of small, efficient, variable-speed blowers. In the first prototype, the exhaust fan was a 140-mm centrifugal blower from EBM Papst (model G1G140). This contained an electrically commutated motor that accepted a digital input (0-10VDC) to control the blower speed. This blower was reliable, quiet, and efficient (using 3–18 W depending on flow rates and other conditions).

The speed of this EBM blower was controlled by the programmable logic controller, which received readings from a flow station in the exhaust air stream, compared these values to programmed flow set points, and used a proportional-integral module to adjust the blower speed accordingly. This control method was very reliable, but it required a flow measurement device. Although a commercial product would certainly not need a flow station as accurate as SWA used for testing, the cost of a flow measurement device would likely be substantial. SWA considered hot wire devices, velocity pressure probes, differential pressure measurements across the ERV core, and even calibrated static pressure at certain points and conditions. All of these would require relatively costly instrumentation and control peripherals.

When Phase II testing showed that an outdoor air fan would also be necessary, SWA assessed many different options (including forward- and backward-curved centrifugal fans, a “cassette” fan, and axial fans). All of these were variable speed, but all would require some sort of flow measurement for proper control. Although some of these fans showed promise, a design goal was to use the same blower model for both the outdoor and exhaust air streams.

As Phase II tests were under way, SWA and Therma-Stor became aware of new “constant-flow” fans that were approximately the right size for this application. These constant-flow fans are also electronically commutated with an analog input, but this analog input is proportional to flow rate (rather than to current or rpm as in previous products). The appeal of this was tremendous. On



paper, these fans promised to deliver constant flow regardless of operating pressures (within limits, of course). Such devices would obviate the need for flow measurement devices.

SWA received fans advertised as constant flow from two Asian manufacturers, but tests quickly showed that these fans did not in fact provide constant flow. This discrepancy was caused in part by language barriers, but it also seemed that manufacturer literature was advertising “potential” features rather than actual features. In perusing products from dozens of manufacturers, SWA found a 120-mm blower from Rosenberg (their Ecofit line) that had promise.

***Rosenberg Testing***

SWA purchased four Ecofit N45-A1 fans from Rosenberg. In benchtop testing, these fans seemed to match literature values quite well. Figure 17 shows that, for a given input voltage, the blowers maintained quite constant flow up to nearly 1 in. w.g. The fan curves from the manufacturer literature are shown in Figure 18.

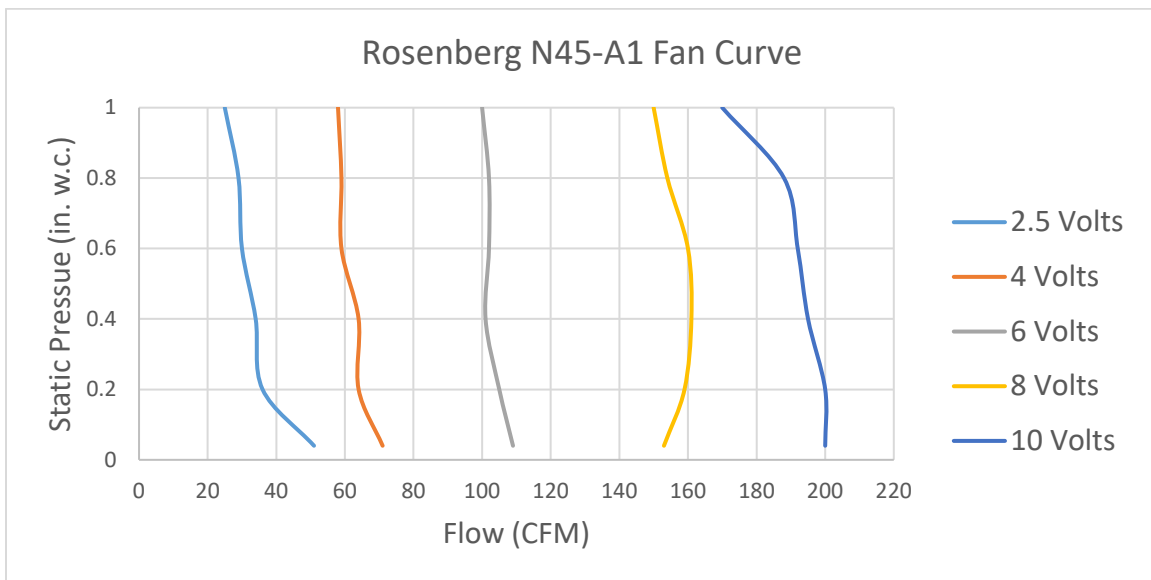

Figure 17. Fan curves from testing Rosenberg Ecofit N45-A1 at various voltage settings

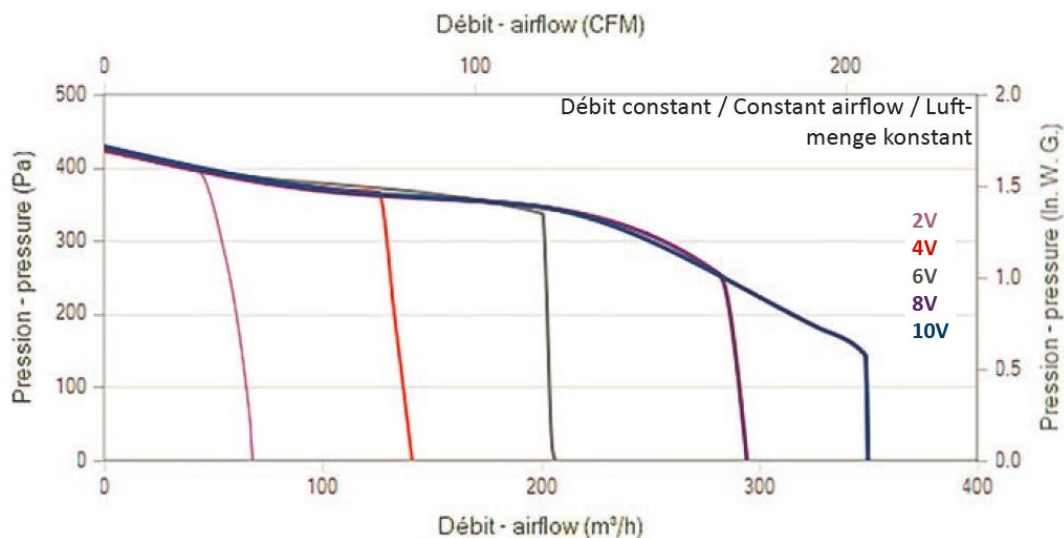

Figure 18. Fan curves for Rosenberg Ecofit N45-A1 from manufacturer literature

Image courtesy of Rosenberg

SWA installed the Rosenberg Ecofit N45-A1 fans in the Phase III prototype for winter testing. The blowers maintained constant flow admirably through the testing (as can be seen in winter test results section that follows), but they drew more power than desired and were quite loud. Table 9 shows more detailed test data (including power consumption) for flow rates specifically of interest for the VICS. In addition, procuring these blowers was not easy. They were expensive (more than \$300 each for samples; palette quantities quoted at approximately \$200 each), and the lead time was 3–4 months.

Table 9. Rosenberg Ecofit N45-A1 Benchtop Flow Test Results

| Differential Pressure<br>(in. w.c.) | 3 Volts |      |    | 4.5 Volts |      |      | 6.5 Volts |      |    |
|-------------------------------------|---------|------|----|-----------|------|------|-----------|------|----|
|                                     | CFM     | RPM  | W  | CFM       | RPM  | W    | CFM       | RPM  | W  |
| 0.04                                | 58      | 780  | 5  | 82        | 1080 | 8.8  | 118       | 1560 | 20 |
| 0.2                                 | 46      | 1260 | 8  | 76        | 1380 | 12.3 | 119       | 1740 | 25 |
| 0.4                                 | 41      | 1620 | 11 | 71        | 1740 | 16   | 120       | 2040 | 31 |
| 0.6                                 | 38      | 1920 | 15 | 71        | 1980 | 21   | 123       | 2280 | 39 |
| 0.8                                 | 38      | 2160 | 18 | 70        | 2220 | 25   | 121       | 2520 | 45 |
| 1                                   | 38      | 2460 | 22 | 69        | 2400 | 29   | 118       | 2700 | 50 |

**Fans-Tech Testing**

After seeing success with the new control technology from Rosenberg, SWA continued talking with many manufacturers to identify constant-flow products that would be quieter, use less power, cost less, and be easier to procure. SWA began discussions with Fans-Tech, a longtime fan supplier for Therma-Stor, about their ability to provide constant-cfm fans. Fans-Tech had a 120-mm blower with constant flow control that, on paper, looked quite similar to Rosenberg’s N45-A1.

To keep dimensions of the VICS on the smaller side, SWA had initially targeted 120-mm-diameter fans for the Phase III prototype. Based on our tests and published data, however, we determined that these fans consumed too much power to meet performance goals. While researchers did not conduct acoustic tests, it was apparent—simply from qualitative assessments—that these blowers were also too loud to be acceptable in many applications. SWA, therefore, asked Fans-Tech about availability of a 140-mm centrifugal blower with constant flow control. Although Fans-Tech did have several 140-mm blowers, they had not yet manufactured one with constant flow. They were willing and able to make them, however. Figure 19 shows fan curves from Fans-Tech (dashed lines) along with SWA’s curves from benchtop testing. Table 10 shows that power consumption of the Fans-Tech 140-mm was considerably less than that of the Ecofit (especially at higher flow rates and static pressures). Initial tests of the Fans-Tech 140-mm looked very good, and SWA retrofitted the Phase III prototype with these blowers before summer testing began.

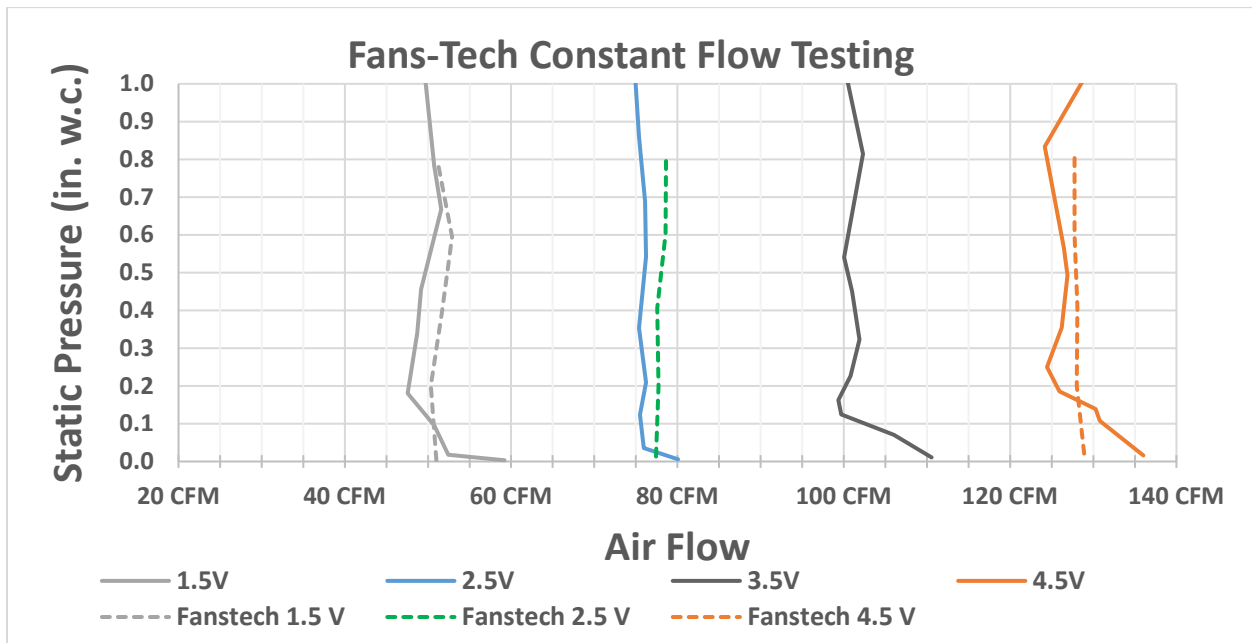

Figure 19. Fan curves from Fans-Tech (dashed) and SWA (solid) for Fans-Tech 140-mm constant flow blower

**Table 10. Comparison of Fans-Tech vs. Rosenberg Power Consumption When Installed in the VICS Prototype**

| Flow (CFM) | Fans-Tech 140-mm Power (W) | Ecofit N45 Power (W) |
|------------|----------------------------|----------------------|
| 50         | 7.7                        | 7.6                  |
| 75         | 11.8                       | 26.2                 |
| 90         | 18.8                       | 35.2                 |
| 120        | 38.1                       | 76.8                 |

Finally, the cost of the Fans-Tech fans was approximately \$60 each—less than 20% of the cost of the Ecofit blowers. The team has not yet discussed quantity pricing, but even the cost of these prototypes was 30% of the quoted quantity price for Ecofit blowers. As Therma-Stor already procures products from Fans-Tech, it is likely that this blower will be used in future products.

#### 4.1.2 Core Selection

For the earliest prototypes, the selection of an ERV core was driven by two key factors:

- Meeting recovery effectiveness goals
- Low flow resistance so negative pressure from the AHU could draw in outdoor air.

Of course cost, size, and durability were always factors, but they were somewhat secondary for the earliest proof-of-concept device. Because of the pressure drop concerns, the alpha prototype (Phase I and II) used an ERV core from CORE with 2.5-mm plate spacing rather than 2-mm spacing. This lowered the pressure drop, but it also lowered recovery effectiveness. At the highest flow rates (120 cfm), the first prototype fell short of the 70% sensible recovery goal.

The addition of the outdoor air blower largely obviated the core pressure drop constraint. When planning for the Phase III prototype, SWA considered the following to optimize space, cost, and effectiveness:

1. Narrower plate spacing
2. Other dimensions (shorter, wider, longer)
3. Counter-flow (hexagonal) cores
4. CORE’s new “Mustang” product
5. Products from other manufacturers.

Table 11 shows a sample of the manufacturers’ published performance values for several different cores. The first row shows the core used in the alpha prototype in Phase I and II of the project. All of the other cores were compared at 17-in. length simply because this was a dimension available from both manufacturers and was close to the core used in the alpha prototype. Note that CORE’s Mustang line is unique in that there are spacers between plates in

only one of the airflow pathways (either exhaust or outdoor air); this is the reason for the two pressure drop values in the table.

**Table 11. Comparison of Manufacturer Values for Several ERV Cores at 120 cfm at HVI Test Conditions**

| Manufacturer —Model              | Dimensions (HxWxD)          | Plate Spacing | Total Eff. (Summer) | Sensible Eff. (Winter) | Pressure Drop (in. w.c.) |
|----------------------------------|-----------------------------|---------------|---------------------|------------------------|--------------------------|
| CORE (Phase II)                  | 12 x 12 x 18in.             | 2.5 mm        | 59.7%               | 68.5%                  | 0.17                     |
| CORE—Mustang                     | 10 x 10 x 17 in.            | 2 mm          | 57.6%               | 69.9%                  | 0.15/0.32                |
| CORE—Mustang                     | 10 x 10 x 17 in.            | 2.6 mm        | 54.8%               | 66.9%                  | 0.12/0.16                |
| CORE—Mustang                     | 12 x 12 x 17 in.            | 2 mm          | 67.2%               | 78.2%                  | 0.18/0.22                |
| CORE—Mustang                     | 12 x 12 x 17 in.            | 2.4 mm        | 61.9%               | 71.8%                  | 0.10/0.20                |
| Innergy Tech —Cross Flow         | 10 x 10 x 17 in.            | 2.3 mm        | 57.6%               | 70.6%                  | 0.12                     |
| Innergy Tech —Cross Flow         | 12 x 12 x 17 in.            | 2.3 mm        | 62.0%               | 72.6%                  | 0.11                     |
| Innergy Tech —Counter Flow (Hex) | 14.5 x 14.5 square x 17 in. | 2.3 mm        | 64.9%               | 75.6%                  | 0.16                     |

Many of the most efficient ERVs available currently use hexagonal, counter-flow, heat exchanger cores. These allow higher recovery in a similar footprint, but this comes with higher cost and pressure drop. Quotes from Innergy Tech showed counter-flow cores were more than twice as expensive as their cross-flow cores. CORE’s Mustang core is a premium product, but it is substantially less expensive (and nearly as effective) as cross-flow products evaluated. For Phase III, the team ultimately selected CORE’s Mustang with dimensions of 12-in. x 12-in. x 20-in. and 2.4-mm plate spacing.

#### 4.1.3 Frost Prevention

The team used the tempering approach for frost-prevention in the beta prototype design as described in Section 3.1.4. As Figure 11 shows, a modulating damper (at the red arrow) was installed between the return air stream and the outdoor air intake duct. As the damper opened, return air was added to the outdoor air stream. This damper could modulate to keep the air entering the core above a certain threshold (20°F for SWA’s tests). A goal for Phase III was to further evaluate and refine this approach.

This tempering approach is very appealing from thermodynamic and indoor air quality perspectives, but it does require additional controls to maintain the desired amount of outdoor air. The design has moved away from flow measurement devices to blowers with built-in constant flow controls. With this tempering arrangement, the outdoor air blower moves a combination of outdoor air and indoor air (used for tempering). For example, if 100 cfm of 10°F outdoor air is brought into the system, 20 cfm of 70°F air may be needed to avoid freezing in the core. The blower would then need to be controlled to deliver 120 cfm (rather than the 100 cfm of outdoor air desired). The total volume of mixed air that must be moved by the blower can be calculated using the ratio of air temperatures (below). This requires three temperature sensors and a control logic, however. It also assumes that “mixed” air entering the core is indeed well mixed.

$$\dot{V}_M = \dot{V}_O \left( \frac{T_O - T_I}{T_M - T_I} \right)$$

Where:

$\dot{V}_M$  = Mixed airflow set point (through blower)

$\dot{V}_O$  = Outdoor airflow set point

$T_O$  = Temperature of outdoor air

$T_I$  = Temperature of indoor air (mixed into outdoor air)

$T_M$  = Temperature of mixed air entering core

Initially, the beta prototype had a tempering damper as illustrated in Figure 20. This configuration had problems, as at times the outdoor air fan competed with the AHU fan. This was obvious in hindsight, and the tempering damper was moved outside of the VICS box as shown in Figure 20. This scenario simply introduced indoor air from near the AHU. This would not always be appropriate in homes, so the team envisions that a small (3-in.) duct could run elsewhere in the home. If this is not possible, tempering air could be drawn from the supply plenum (Figure 21). Supply air will obviously be at higher pressure and often much warmer, but the volume can be controlled by the damper. SWA tested both configurations.



Figure 20. The tempering damper allowed room air to mix with outdoor air before passing through the core



Figure 21. Tempering air for frost prevention drawn from AHU supply plenum

#### 4.1.4 Beta Prototype Design

Although designing a relatively small, compact device was always a consideration, the beta prototype was considerably larger than a production model will likely be. SWA needed extra space for:

- Installing and testing multiple blowers
- Keeping sensors, wiring, and controls functional, organized, and accessible
- Testing multiple frost prevention strategies
- Possibly testing different cores
- Clearance and general access for testing, adjustments, and troubleshooting.

SWA's initial beta design is shown in Figure 22. Therma-Stor offered to manufacture the prototype for testing, and they adjusted the design somewhat to make the system easier to manufacture (see Figure 23). An image of one prototype in Therma-Stor's factory is shown in Figure 24, and the system installed in SWA's Connecticut facility is shown in Figure 25.

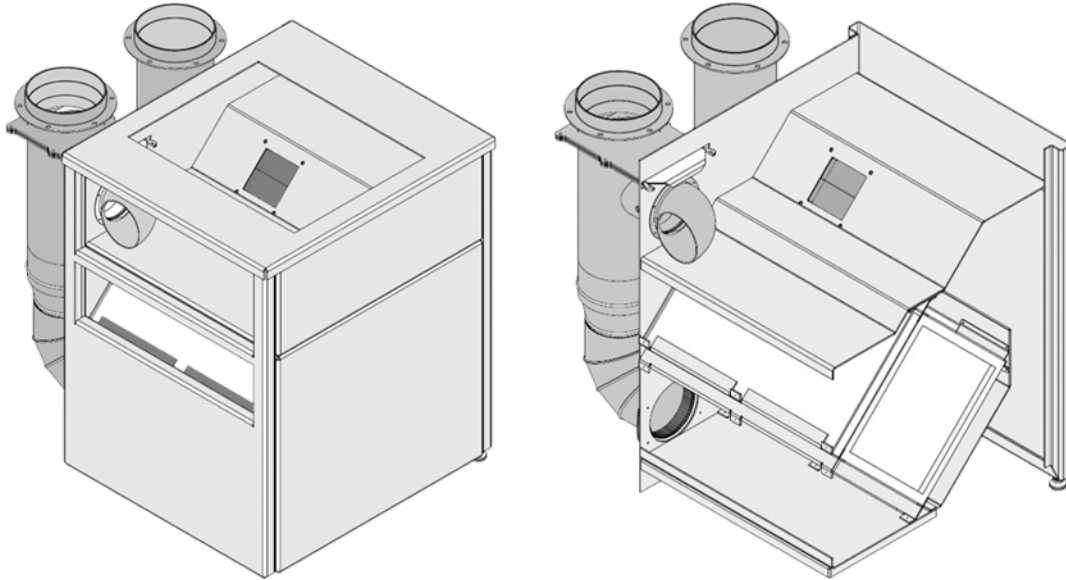

Figure 22. SWA CAD design of VICS beta prototype

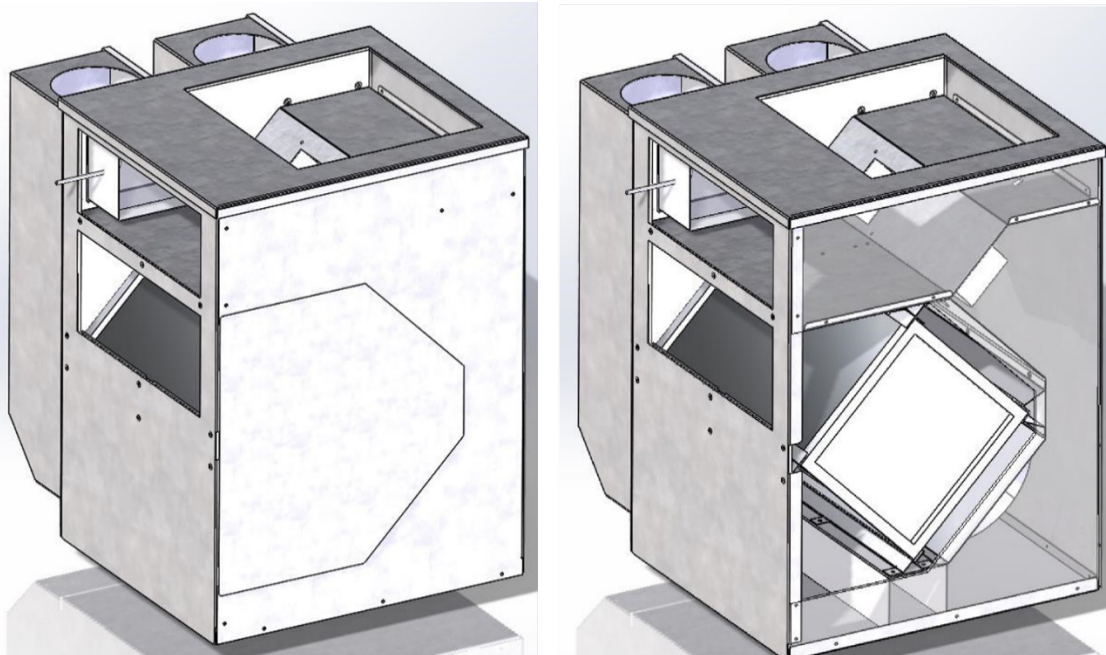

Figure 23. Manufacturer design revisions for improved manufacturability





Figure 24. Beta prototype in Therma-Stor's factory

Figure 25. Beta prototype installed in Connecticut

The images show the overall configuration is not dramatically different from the initial beta design, but there are several differences. The blowers were oriented at 45° to lower the overall height of the system. There was some concern about fan longevity at this angle; this will be addressed in preproduction designs.

## 4.2 Phase III Research Questions

When SWA installed and tested this prototype, the key research questions were:

- Can the prototype deliver the high target outdoor airflow rates of 120 cfm at various duct configurations (outdoor air ducts and supply ducts)?
- Are outdoor airflow set points maintained to within 5–10 cfm?
- Are exhaust airflow set points maintained to within 5–10 cfm?
- What is the power consumption of the VICS with various duct configurations and ventilation flow rates (40, 70, and 120 cfm)?
- Is the VICS capable of providing recommended tempering for frost prevention as recommended by CORE at each flow rate (40, 70, and 120 cfm)?
- Upon change of a ventilation flow rate set point, is the system able to reach the new set point within 5 minutes (within 10 cfm)?
- When a call for heating or cooling begins or ends (or when the AHU fan changes speed), what is the effect on ventilation flow rates? Do these flow rates return to set point (within 5–10 CFM) within 5 minutes?

- Does VICS operation impact the total airflow rate through the air handler at varying fan AHU speeds and ventilation flow rates?
- What is the additional power consumption of the VICS at various flow rates during heating/cooling? Is this below the 30 W target at 120 cfm?
- What are the overall sensible and total heat recovery effectiveness values at the range of conditions tested? At conditions near rating conditions, is winter sensible effectiveness at least 70%? Is total summer effectiveness at least 50%?
- Do measured sensible effectiveness values meet the design criterion of 70% at flow rates used (during winter conditions similar to rating conditions)?
- Do measured total effectiveness values meet the design criterion of 50% at flow rates used (during summer conditions similar to rating conditions)?
- During cooling, how do conditions of air (especially wet bulb) entering the heat pump differ from return air conditions? What are the implications for heating or cooling efficiency?
- What are the lowest AHU supply air temperatures delivered during the winter? Will these be above the 62°F required by Passive House standards?

Instrumentation was very similar to other phases; details are provided in Appendix A. Initial plans were to install the beta prototype in the lab, assess performance and control functionality, then deploy in an occupied home. During lab testing, however, it was clear that the team's effort would be much better spent refining the design and control for a production model.

### 4.3 Winter Testing

During winter testing, the prototype contained:

- Two Rosenberg Ecofit N45-A1, 120mm, constant-flow blowers
- CORE Mustang ERV core: 12-in. x 12-in. x 20-in. x 2.4-mm spacing
- Modulating, frost-prevention tempering damper initially located in the mixing plenum. This was moved to the outdoor air duct when performance was not adequate.

#### 4.3.1 Maintaining Ventilation Flow Rates

One limitation of the VICS under most operating conditions was the low end of the flow range. The team initially targeted a ventilation range of 40–120 cfm, but the viable low end of the flow range in this prototype was 50 cfm. The constant-flow fans had a hard time maintaining consistent flow rates below 50 cfm. In addition, negative pressure from the air handler resulted in outdoor airflow rates of approximately 50 cfm when the outdoor air blower was completely off. Although a larger range is more desirable, there are relatively few applications where a minimum flow of 50 vs. 40 cfm would have significant negative impacts. This may be re-examined in the future.

The constant-flow Rosenberg Ecofit fans performed as advertised. Flow rates were maintained very well. Within 1–2 minutes of a change in ventilation set point or change in demand for heating, the Rosenberg blowers adjusted to deliver flow rates within 5 cfm of set points. A graphical example of this is in Figure 26.

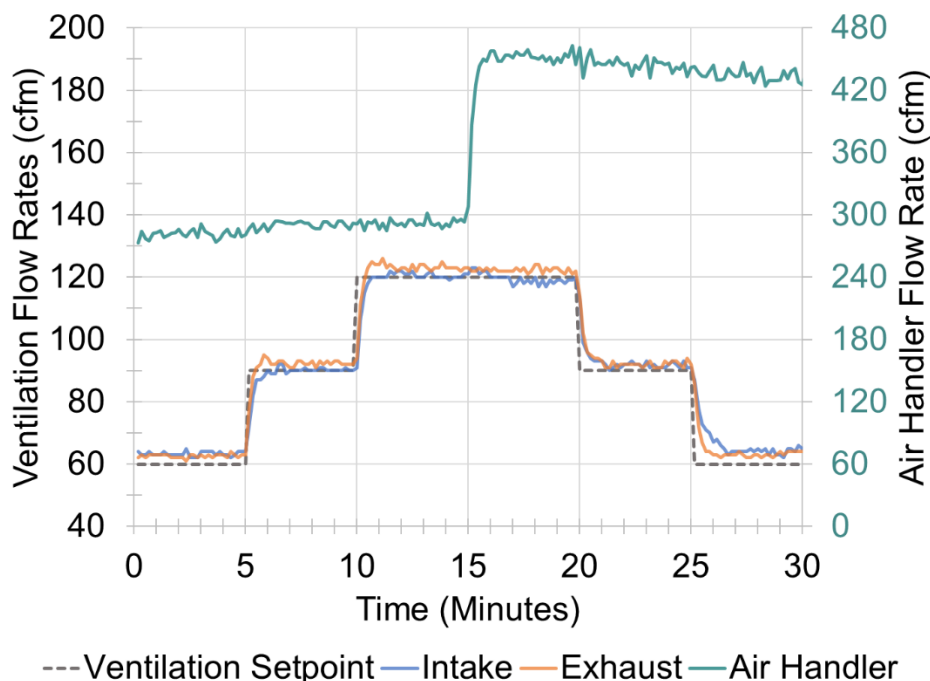

Figure 26. Ventilation flow rates are maintained at set point with changing AHU operation

### 4.3.2 Frost Prevention

As discussed in the beta prototype design section (4.1.3), the location of the frost prevention damper was moved from inside the mixing plenum to the outdoor air intake duct. When in the mixing plenum, the outdoor air fan competed with the AHU fan for outdoor air. When the damper was moved, SWA achieved adequate frost-prevention flow rates under all conditions.

Figure 27 demonstrates the results of tempering for frost prevention. The control algorithm compares the temperature of the outdoor air entering the core to the minimum allowed to prevent frost (20°F in these tests). If air entering the core drops below 20°F, the modulating frost-prevention damper opens 10° (allowing some indoor air to enter the outdoor air stream). After one minute, if the air entering the core is still below 20°F, the damper opens another 10°. This continues until the air entering the core rises above the minimum.

Air entering the core is represented by the orange “Core Temp” line in Figure 27. It is noteworthy that opening the damper 10°, 20°, and even 30° has little impact on air entering the core. Jumping from 30° to 40°, however, caused nearly a 5°F rise in air temperature. Clearly,

some refinement of the controls are needed. Unfortunately, there was not a tremendous amount of very cold weather in Connecticut during the testing, so future refinements are needed.

Another refinement needed is in the damper itself. As Figure 27 shows, outdoor air temperature was 15°F during these tests, but air entering the core was nearly 20°F when the damper was completely closed. Overall insulation of the VICS needs to be improved (this is discussed in design of the next prototype), but the damper also leaks a small amount when fully closed. More refinements are needed.

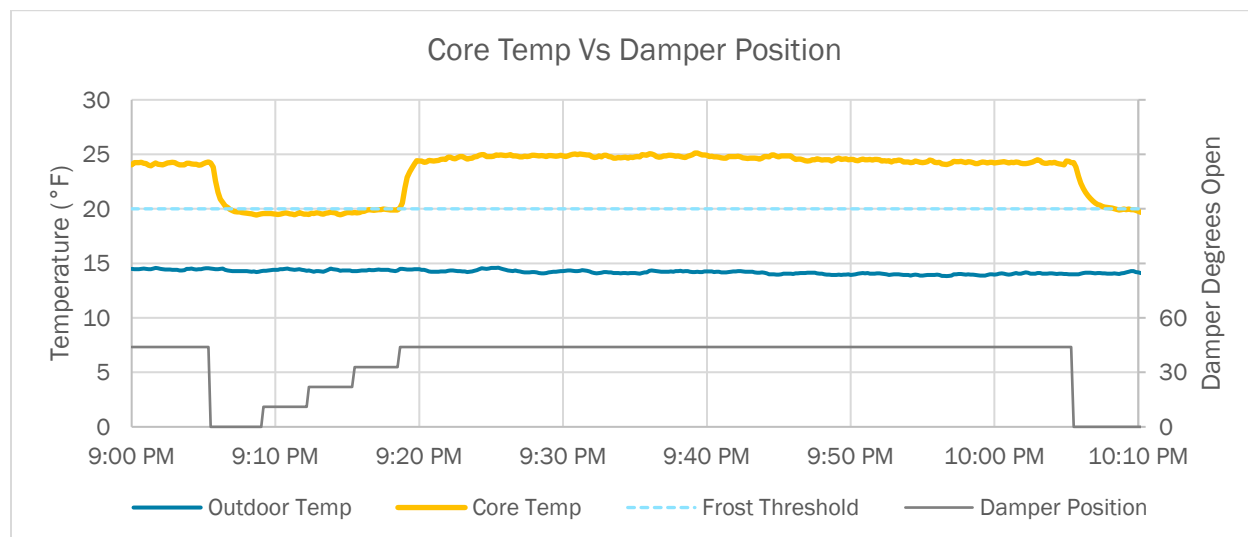

**Figure 27. Impact of frost-prevention tempering damper actuation on air temperature entering core**

When more indoor air is introduced into the outdoor air stream, the outdoor air blower must increase its speed to deliver the target levels of “true” outdoor air. This calculation is made using temperatures of the three air streams (indoor air, outdoor air, and mixed air entering the core) as discussed in Section 4.1.3. Figure 28 shows the same period of time as Figure 27. The gray dashed line represents the outdoor airflow set point (starting at 90 cfm, stepping to 120, then dropping to 50 cfm). The solid blue “OA Flow” line is nearly always within 5 cfm of the set point. When the ventilation set point rises to 120 cfm (at 9:05 PM), outdoor air flow spikes to approximately 130 cfm but drops back to within 5 cfm of 120 cfm within 4 minutes. At 9:18 p.m. when the tempering damper opens enough to significantly change the mixed air temperature, outdoor airflow drops 10 cfm, but again it climbs back to 120 cfm within 4 minutes. Refinements in control and air sealing are certainly needed, but this frost-prevention method has promise to be very efficient and functional.

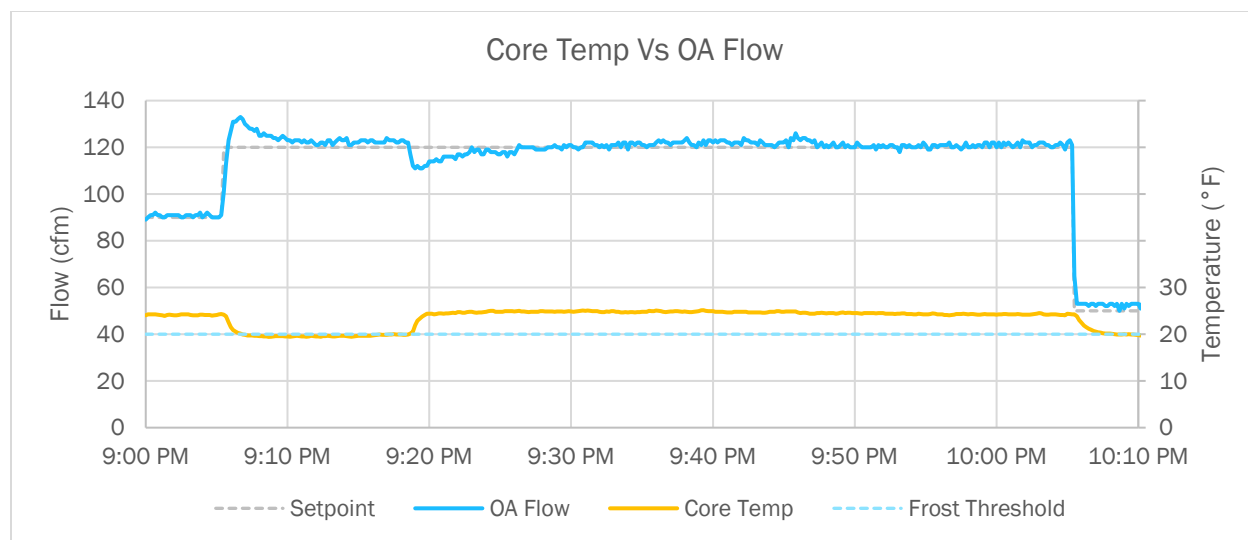

Figure 28. Outdoor airflow rates maintained during changes of set point and tempering damper position

### 4.3.3 ERV Effectiveness

Overall, the ERV effectiveness values that SWA measured in the winter were somewhat lower than those listed by CORE. Uncertainties in the measurements were significant, however, and there were two other factors that may have compromised the measured effectiveness:

- Thermal bridging (between quadrants of the ERV).
- Air leakage, especially from the frost-prevention damper. Even when closed, leakage through the damper resulted in flow rates through the core slightly higher than measured by the flow station.

This damper assembly was adapted by Therma-Stor from another product where air leakage or bypass through the damper was not a significant concern. Such leakage is a major concern with the VICS, and this will certainly need to be addressed in the future.

Table 12. Typical Winter Sensible Effectiveness with Outdoor Air Temperatures of 30°–40°F

| Outdoor Airflow [scfm] | Outdoor Temp [°F] | Indoor Temp [°F] | Sensible Effectiveness |              |
|------------------------|-------------------|------------------|------------------------|--------------|
|                        |                   |                  | Measured               | Manufacturer |
| 53                     | 34.9              | 71.9             | 72% ± 23%              | NA           |
| 76                     | 33.6              | 71.5             | 71% ± 16%              | 77.3%        |
| 91                     | 35.9              | 73.0             | 66% ± 12%              | 75.9%        |
| 121                    | 39.2              | 74.3             | 60% ± 9%               | 73.4%        |

Insulation, air sealing, and thermal bridging were weak points in these prototypes; some of these details were not communicated well between SWA and Therma-Stor. Before installing the prototype, SWA meticulously sealed the system. SWA used a Duct Blaster to assess leakage (Figure 29), and leakage was reduced to below 6 cfm at 25 Pa (near the measurement threshold of the device).



**Figure 29. The entire cabinet was sealed and leak tested using a Duct Blaster**

SWA insulated the quadrants of air leaving the ERV core with 0.5 in. of flexible foam (approximately R-2.5, see Figure 30). The other surfaces were insulated by Therma-Stor to similar R-values. The blowers were not insulated, as SWA envisioned needing to remove and test multiple blowers. While the exterior of the core sections are insulated from ambient indoor air (as shown in Figure 30), there was no insulation on the inside of the steel that runs between the two sections of the core. After effectiveness values were much lower than expected, SWA performed THERM modeling to quantify this bridging. THERM results indicated that this thermal bridge did not explain the entire discrepancy between measured and expected effectiveness values.



**Figure 30.** After sealing, SWA insulated portions of the ERV where air leaves the core with 0.5 in. of foam. The one other factor that was problematic during winter testing was air leakage from the frost-prevention damper. As discussed previously, SWA tested multiple locations and configurations of the frost prevention damper. As the flow station was located upstream of the frost prevention damper, any tempering air introduced was not measured. SWA attempted to correct this based on the ratio of temperatures (outdoor air, return air, tempered air), but this calculation was imperfect, especially as insulation and thermal bridging were also issues.

SWA attempted to eliminate both of these factors by:

- Adding a thin layer of insulation inside the steel on the two quadrants exiting the ERV core
- Completely sealing the tempering air inlet.

Unfortunately, after making these modifications, there was not enough cold weather to assess ERV effectiveness. These modifications were in effect for summer testing, however, when measured and manufacturer performance values agreed very closely.

#### **4.3.4 Power Consumption**

Although the Ecofit blowers maintained flow rates very well, at higher flow rates the power consumption exceeded acceptable levels. Table 13 shows the typical power consumption for the two Rosenberg Ecofit blowers in the VICS. These values do not include the power consumption of the AHU. When the Mitsubishi AHU was running on low speed (as it would without a heating or cooling mode), it consumed 30–35 W. When delivering 120 cfm of ventilation, the power of

the Rosenberg Ecofit blowers plus the power of the AHU totaled over 110 W. This greatly exceeding the target maximum of 70 W.

**Table 13. Typical Power Consumption During Winter Tests; Power Values Do Not Include the AHU Fan Energy of 30–35 W**

| Nominal Flow [cfm] | Rosenberg Blowers Power [W] |
|--------------------|-----------------------------|
| 50                 | 7.6                         |
| 75                 | 26.2                        |
| 90                 | 35.2                        |
| 120                | 76.8                        |

#### 4.4 Summer Testing

After winter testing was completed and before summer testing began, SWA made four noteworthy changes to the prototype.

1. Blowers. Although the Ecofit 120-mm fans performed admirably in maintaining constant flow rates, they were fairly power hungry and resulted in significant noise at higher flow rates (from qualitative assessment only). During the winter, SWA had been communicating with several other fan manufacturers, and Fans-Tech was ultimately able to provide 140-mm blowers with constant flow control capabilities. The 140-mm blowers are larger, but on paper and in benchmark tests the power consumption and noise were both substantially lower. Before summer testing, SWA installed the Fans-Tech blowers into the prototype.
2. SWA removed the frost-prevention tempering damper and completely sealed that opening. Leakage here was not an issue in summer tests.
3. Insulation and thermal bridging in the ERV was a concern during winter tests, and SWA added a thin layer of insulation against some of the components suspected of bridging.
4. Supply ductwork from the VICS was added. The system provided continuous ventilation to three office spaces during the summer.

The system was operated continuously for four months, but the ventilation set points (both supply and exhaust) changed every 2 hours stepping through the following rates: 50, 75, 90, and 120 cfm. This staging was merely for evaluation purposes; it was not related to ventilation needs of the offices.

##### 4.4.1 Maintaining Ventilation Flow Rates

The Fans-Tech blowers proved equally capable of maintaining constant flow rates under varying conditions. One difference with the larger blowers was the low end of the outdoor airflow range. With the outdoor air fan not powered, negative pressure from the AHU induced outdoor airflow rates of 50–60 cfm. A longer or more restrictive duct would reduce this, but a manual damper may be needed to consistently provide flow rates below 60 cfm.



#### 4.4.2 ERV Effectiveness

Unlike in the winter tests, during the summer SWA’s measured ERV performance matched CORE values very closely. Measurement uncertainty is still considerable (even higher for total recovery effectiveness), but SWA believes that the added insulation and sealing (of the frost-prevention damper) made a difference in accurately assessing the core’s performance.

**Table 14. Sample Summer Performance Tests**

| Set Point | Outdoor Air |       | Return Air |       | Tempered Outdoor Air |       | $\epsilon_{sens}$ |     | $\epsilon_{total}$ |     |
|-----------|-------------|-------|------------|-------|----------------------|-------|-------------------|-----|--------------------|-----|
|           | CFM         | °F DB | % RH       | °F DB | % RH                 | °F DB | % RH              | SWA | CORE               | SWA |
| 75        | 91.8        | 52%   | 71.7       | 72%   | 76.5                 | 72%   | 80% ± 18          | 80% | 71% ± 22           | 74% |
| 90        | 92.8        | 49%   | 72.0       | 73%   | 76.6                 | 74%   | 78% ± 15          | 77% | 66% ± 20           | 70% |
| 120       | 92.6        | 50%   | 72.6       | 73%   | 76.8                 | 76%   | 79% ± 11          | 74% | 65% ± 19           | 67% |

#### 4.4.3 Power Consumption

Stepping up from the 120-mm blowers to the Fans-Tech 140-mm blowers made a dramatic impact on both power consumption (at higher flow rates) and noise. Table 15 shows the typical VICS power consumption with both sets of blowers. These values do not include the AHU power. During summer testing, the sum of the VICS power and the Mitsubishi AHU power (30–35 W) was almost exactly at the design target of 70 W at 120 cfm. While 140-mm blowers are more difficult to accommodate in a compact cabinet, the power and noise improvements likely justify the larger size.

**Table 15. Typical Power Consumption of VICS with Fans-Tech 140-mm Blowers and 120-mm Ecofit Blowers**

| Flow Set Point [cfm] | Summer, 140mm Fans-Tech [W] | Winter, 120mm Ecofit [W] |
|----------------------|-----------------------------|--------------------------|
| 50                   | 7.7                         | 7.6                      |
| 75                   | 11.8                        | 26.2                     |
| 90                   | 18.8                        | 35.2                     |
| 120                  | 38.1                        | 76.8                     |

## 5 Survey and Market Outreach

In discussions with Therma-Stor and Mitsubishi, it became clear that more feedback from potential VICS users could help to refine the design and more clearly outline the market potential for the project. To gauge market interest and to inform future commercialization decisions, SWA created and launched a short online survey. SWA publicized the project with a two-page informational sheet (Figure 31) and invited survey participation. Target participants were builders, contractors, designers, raters, and other stakeholders who had vested interest in residential ventilation systems. SWA publicized the project and the survey through several channels:

- SWA's Party Walls blog<sup>1</sup>
- Green Building Advisor<sup>2</sup>
- An Energy Design Update article
- An Energy and Environmental Building Alliance newsletter article<sup>3</sup>
- E-mail blasts to NYSERDA's Home Performance with ENERGY STAR contractors
- CT Green Building Council newsletter
- Housing Innovations Research Lab newsletter
- ENERGY STAR Homes stakeholder meeting
- Direct e-mails to colleagues, clients, and others.

---

<sup>1</sup> <https://www.swinter.com/party-walls/erv-ahu/>

<sup>2</sup> <https://www.greenbuildingadvisor.com/article/integrating-erv-air-handler>

<sup>3</sup> <https://eeba.org/the-problem-with-hrvs>

In Development:  
**Integrated Energy Recovery Ventilator**

Steven Winter Associates, Inc.

Building AMERICA  
U.S. Department of Energy

Far too often we see frustrating and difficult ERV installations that fail to meet ventilation requirements. With support from the DOE Building America program and industry partners, Steven Winter Associates is working to address this issue by developing an integrated ventilation system that makes balanced ventilation easier in homes.

Designed to fit into mechanical closets, the small-footprint ventilator will integrate with efficient forced-air systems. ECM fans maintain ventilation rates regardless of heating and cooling operation over a wide range of system configurations.

**Traditional ERV Add-On**

- Larger footprint and maintenance access requirements
- More difficult to install
- Inconsistent flow rates as ERV competes w/ AHU
- Defrost cycles: off, recirculation, exhaust-only, or electric resistance
- Can only commission at a single AHU speed

**Integrated ERV**

- Compact, small footprint
- Minimal connections
- Consistently maintains desired flowrates (even during frost prevention)
- Low electrical power
- Wide range of flow rates

Key Technical Partners:

Therma-Stor LLC  
CORE MITSUBISHI ELECTRIC TRANE HVAC US

**Integrated Energy Recovery Ventilator**

Patent Pending

**Compact:** Connects to the return side of an air handler. Fresh air is distributed throughout the home through heating and cooling ducts. All maintenance needs are executed through the front panel.

**Minimal Connections:** Need only to provide ventilation inlet and outlet ductwork, resulting in two field connections (in addition to the normal AHU setup) instead of four connections typical of non-integrated ERV's.

**Versatile:** The unit will be able to accommodate systems up to 2 tons. Exhaust air can be diverted from return air as shown or ducted separately to provide targeted exhaust.

**Steady Flow:** Constantly modulating ECM fans ensure the delivery of the desired amount of exhaust and outdoor air under

**40-120** Single Unit Specification: delivers ventilation flow rates from 40 cfm up to 120 cfm.

**Energy Recovery:** 70% sensible effectiveness, 50% total recovery efficiency at 120 cfm.

**Enhanced Frost Prevention:** During very cold weather, ventilation flow rates are continuously maintained by mixing return air into the OA stream. There is no need for recirculation, unbalanced ventilation, or power hungry electric preheat.

**MERV 13** High Filtration: Designed for at least MERV 13 filtration of outdoor air.

**Low Power:** Prototypes delivered 120 cfm of ventilation with 40-80 Watts, including the AHU.

Prototype testing in occupied homes is scheduled for Q1 2019.

Send feedback or inquires to [vics@swinter.com](mailto:vics@swinter.com)

Steven Winter Associates, Inc. Building AMERICA U.S. Department of Energy

Figure 31. Two-page summary document released by SWA

When the survey was closed September 27, 2019, SWA had received 95 responses. This does not represent a statistically significant section of the overall market, but it represents building professionals who have an interest in indoor air quality and ventilation. People who are interested enough to take this 5–10 minute survey are likely some of the first target customers of a commercial VICS product.

### 5.1 Survey Questions and Results

Figure 32 through Figure 44 show the survey questions and responses; the questions are shown in the title of each graph. The survey questions generally fall into these four categories:

- Demographics (location, type of buildings worked on, volume of residential work)
- Current ventilation practices
- Experiences with ERVs
- Relative appeal of features and aspects of the VICS approach.

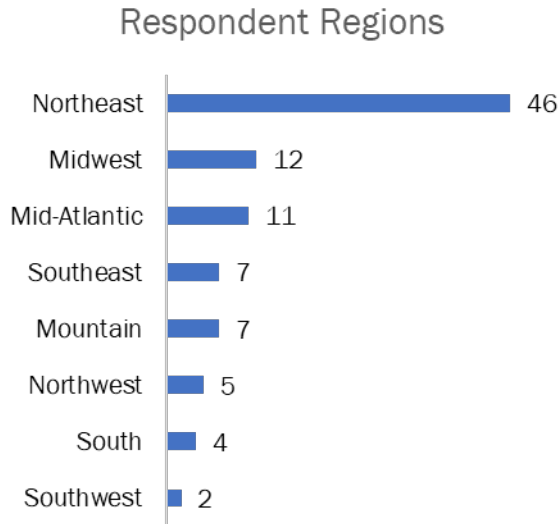

Figure 32. Primary work regions of respondents

What building type do you most typically work on?

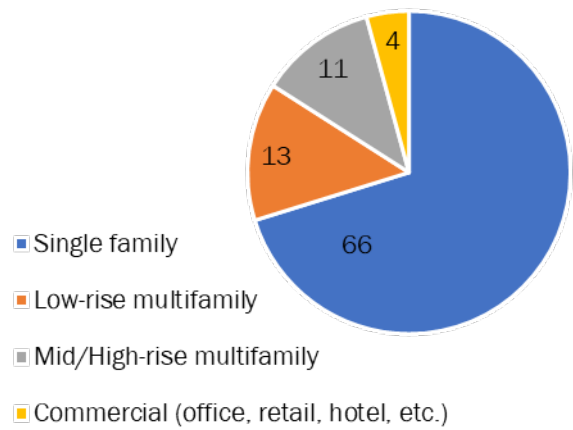

Figure 33. Most common building types

Approximately how many homes or dwelling units do you work on annually?

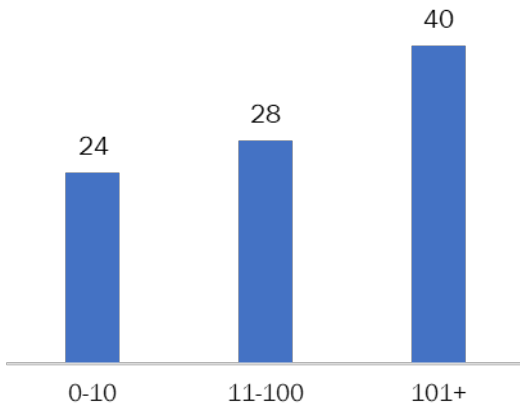

Figure 34. Number of dwellings

Which type of residential whole-building ventilation system do you most commonly specify or install?

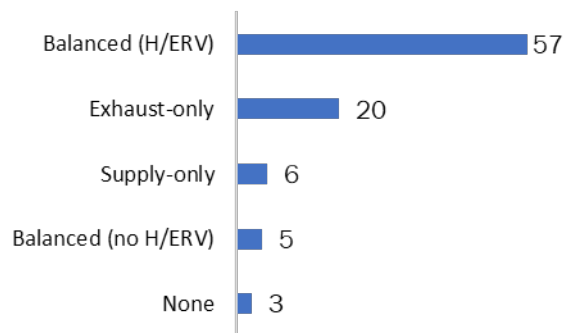

Figure 35. Type of ventilation

If specifying or installing a heat recovery ventilation system, which do you usually prefer?

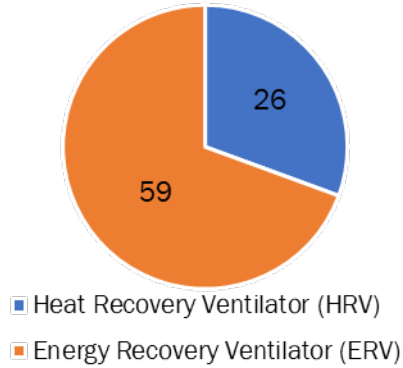

Figure 36. ERV or HRV

What level of filtration do you specify for whole-house ventilation?

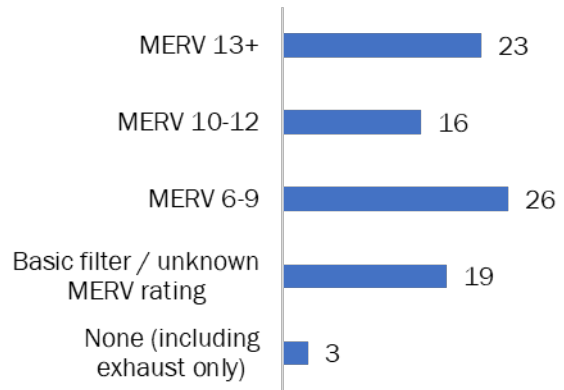

Figure 37. Filtration level

If you install or specify H/ERVs, what is your typical approach to local and whole-house ventilation?

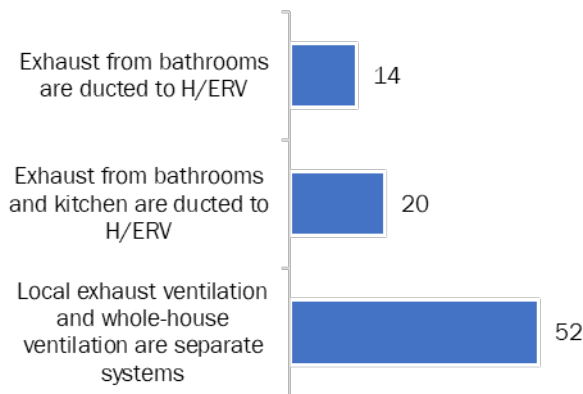

Figure 38. Local ventilation practices

If specifying or installing an air handler unit for space heating and cooling, which configuration do you usually prefer?

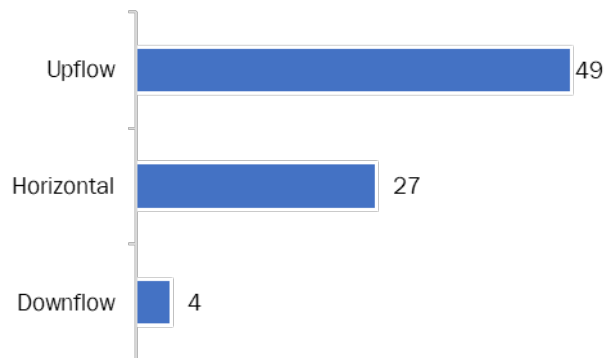

Figure 39. AHU orientation

### Program Participation

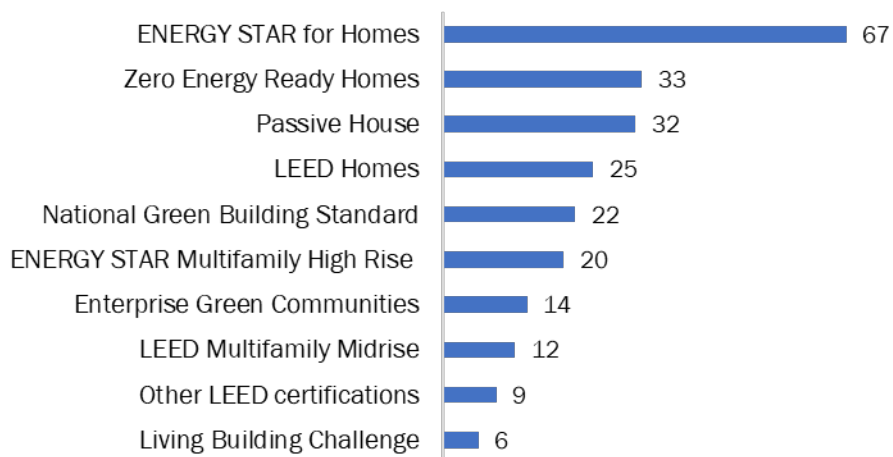

Figure 40. Respondents were asked to select all above-code programs in which they participate

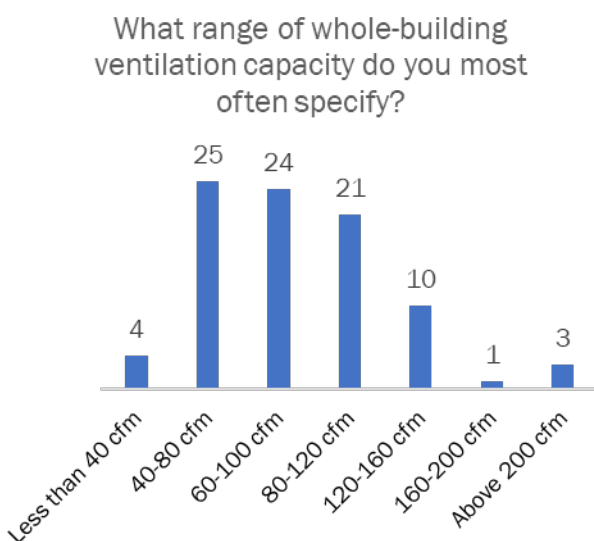

Figure 41. Typical ventilation ranges

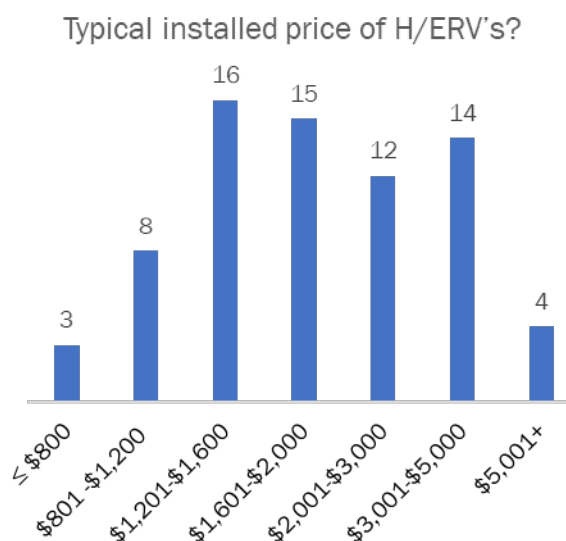

Figure 42. Typical cost per dwelling if using H/ERVs

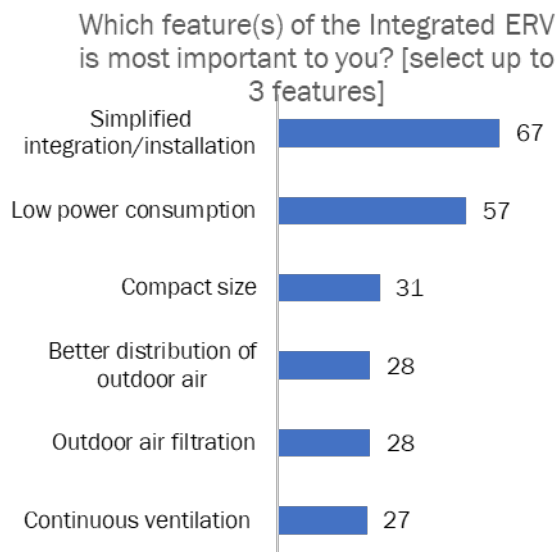

Figure 43. Important VICS features

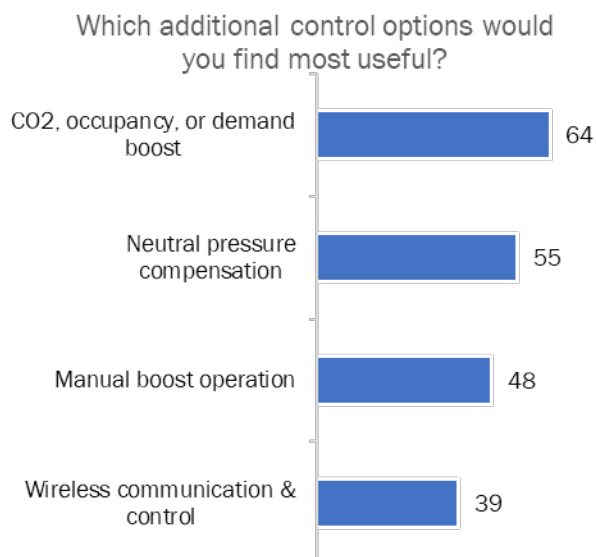

Figure 44. Respondents selected any/all desired control features

## 5.2 Survey Results Discussion

Most respondents were in the Northeast (where SWA is most active), and most worked on single-family homes rather than multifamily. Researchers were somewhat surprised that most respondents worked on projects where H/ERVs were standard (Figure 35). This certainly does not reflect the market as a whole, but it follows that practitioners who use ERVs would be most interested in streamlining ERV installation and integration (and participating in a survey).

Overall, survey results reinforced SWA’s belief that there is interest in a simpler, integrated ERV option. Eighty percent of respondents indicated that their typical ventilation rates align with the capabilities of the VICS design (40–120 cfm, Figure 41). The target installed price point for the VICS (\$2,000) is in the middle of the range of current installed costs (Figure 42). The most appealing factor of the VICS concept was simplified installation and integration (Figure 43). Low power consumption was second—beating out compact size. Researchers were pleased by this, as thermal and electrical efficiency was given some preference over compact size during design.

The current VICS design can accommodate many of the varying preferences of survey respondents.

- MERV 13 is easily accommodated and likely would be standard (Figure 37)
- Collars attached to the exhaust opening can handle local exhaust from bathrooms and/or kitchens (Figure 38)
- Upflow, horizontal, and downflow configurations are all feasible with the current design (Figure 39).

The current VICS product is an ERV, but an HRV product is a logical next step (Figure 36). Because an HRV would require condensate drainage, there are added implications on system orientation. Reviewing these results with Therma-Stor was encouraging, but quantifying the overall market is tremendously important when making new product decisions. This is discussed in more the following discussion section.



## 6 Discussion

### 6.1 Meeting Initial Goals

In an early project milestone (Design and Performance Specifications), SWA compiled the key performance parameters shown in Table 16. The column at the right summarizes if or how the goal was achieved. Overall, SWA is very pleased with the results and performance of the prototype. The preproduction design (not discussed here) will further improve performance and versatility.

**Table 16. Performance Goals and Results**

| Feature                                | Initial Goal   | Achieved?   |
|--|--|---|
| Heating, cooling, and dehumidification | VICS does not negatively impact efficiency or comfort provided by the heat pump. Increased moisture removal capabilities.  | Yes. There is no negative impact on heating and cooling performance. Improvements in heating and cooling performance are possible but were too subtle to measure.   |
| Ventilation rates                      | Variable up to 120 cfm. Adequate for whole-building ventilation for most homes as required by codes, standards, and/or efficiency programs (often ASHRAE Standard 62.2).   | Yes.  |
| ERV effectiveness                      | ≥70% sensible effectiveness in winter and ≥50% total effectiveness in summer.  | Yes   |
| Filtration                             | Filtration of outdoor air (at least MERV 6 per ASHRAE 62.2), exhaust air (to protect core, exhaust fan, etc.), and return air (as selected by user/installer—capability for high MERV).  | Yes. The goals soon evolved to include MERV 13 filtration on outdoor air, and the VICS can handle that adequately.  |
| Defrost                                | Maintain balanced ventilation as often as possible and minimize defrost downtime (max 15 min/hour in most extreme weather). Minimize energy consumption associated with defrosting, and prevent reduced performance and damage from frost. | Yes. This goal also evolved during the project to provide frost protection with no interruption in ventilation, no recirculation, and no imbalanced ventilation. The tempering strategy addresses all of these issues, though more work is needed on practical integration of a tempering damper. |

| Feature                     | Initial Goal   | Achieved?   |
|-----------------------------|--|---|
| Power consumption           | No more than 70 W in ventilation-only mode; no more than 30 W additional when in heating/cooling mode.   | No, but very close and acceptable based on redesign of the system. The initial design included a single ERV blower. The latest prototype included two, but when providing 120 cfm, the total power of these fans was 35–40 W. The Mitsubishi AHU drew 30–35 W, so the ventilation-only power for the tested prototype was approximately 70 W. |
| Outdoor air ducting         | Provide target ventilation rates with outdoor air supply and exhaust duct work up to 200 ft equivalent length.   | Yes, easily. The latest design uses rather large blowers (140 mm) for power and noise reasons. These blowers could overcome twice the equivalent length of outdoor air duct, though power and noise would increase.   |
| Space/footprint             | Minimal extra footprint above what's needed for AHU. Fit within the footprint of a typical mechanical closet (HxWxD: 96-in. x 40-in. x 36-in.)   | Yes. The latest design has HxWxD dimensions of 30.25-in. x 23.75-in. x 21-in. The Mitsubishi AHU tested has a height of 50 in.; this leaves adequate room for supply ductwork in an upflow configuration.   |
| Wall penetrations           | Single penetration with combined outdoor air/exhaust termination.  | Not addressed in this effort. This will need to be examined in the future.  |
| Maintenance and reliability | Integrate fault detection and diagnostics into control device to alert residents and/or technician about faults, likely reasons for faults, and when maintenance is required.                | Not yet addressed. This and other control factors will be revisited in a commercial system design.  |
| Cost                        | Approx. \$1,500–\$2,000 installed (not including heat pump and indoor duct system). This is approximately 50%–70% of the cost some developers cited for balanced, heat-recovery ventilation. | In conversations with Therma-Stor, the higher end of this range appears achievable.   |

## 6.2 Design Evolution

At the start of the project, SWA believed the VICS concept was viable because of several trends in residential buildings and technology:

- Much smaller design heating and cooling loads
- Smaller capacity heating and cooling equipment—especially inverter heat pumps
- With smaller loads and smaller equipment, the airflow rates for heating/cooling are much closer to the rates needed for home ventilation
- Efficient, variable-speed fans and blowers available in smaller sizes (and at lower costs)

- Growing interest in indoor air quality and demand for balanced ventilation and filtration.

The initial VICS concept utilized negative pressure from an AHU to draw in outdoor air. A damper in the return air stream modulated to draw in more or less outdoor air. Although this worked in initial tests (with caveats), the dramatic negative impact on heat pump performance caused SWA to abandon this approach. The beta prototype included an outdoor air fan as well as an exhaust fan. Because of the efficiency and availability of small variable-speed blowers, the beta prototype came close to initial power goals (which was based on a single fan for ventilation).

Another key advancement in blowers occurred as SWA was developing and testing prototypes: constant flow control. SWA knew entering this effort that monitoring and maintaining ventilation flow rates under a wide range of conditions would be a challenge. Pressure and/or flow measurement devices along with associated controls could have significant costs and maintenance concerns. Small, efficient, variable-speed blowers with constant flow control became available at exactly the right time for inclusion in the beta prototype. This advancement has potential for many residential ventilation systems—not just the VICS.

The initial design of the system was based on the AHU fan drawing in outdoor air. To minimize pressure drop, the size of the core was quite large (compared to cores in other residential ERVs). Once it was determined that an outdoor air fan was necessary, SWA revisited the size and type of the ERV core. This led to a careful examination and optimization of system size/dimensions, cost, and performance. The “performance” parameters include thermal efficiency/effectiveness, power consumption, and flow/pressure ranges. There are many relationships between these parameters, and some are outlined explicitly below:

- Larger cores (both depth and width) have higher recovery efficiencies
- Deeper cores (i.e., more plates) have lower pressure drops
- Wider cores have higher pressure drops
- Hexagonal, counter-flow cores have moderately higher effectiveness for the same “footprint”
- Hexagonal cores have higher pressure drops
- Hexagonal cores are substantially more costly
- Larger blowers use less power (at given flow and pressure)
- Larger blowers make less noise (at given flow and pressure)
- Larger blowers can deliver higher flow rates and/or pressure
- Larger blowers are more difficult to control at low flow rates (below 50–60 cfm)
- Larger blowers are not significantly more expensive than smaller blowers (140 mm vs. 120 mm).

SWA spent considerable time examining trade-offs among these factors when optimizing the VICS design. In the end, the latest design reflects the following optimizations.

### 6.2.1 Size

The VICS is considerably larger than most ERVs in a similar airflow range. A larger height is necessitated in part by the need to accommodate all return air. A larger core and larger blowers necessitate a wider unit, but it is not considerably wider (approximately 6 in.) than many 2-ton AHUs. The system depth (21 in.) is the same as many small, conventional AHUs.

### 6.2.2 Effectiveness

The large, cross-flow CORE Mustang core used in the beta prototype provides thermal performance better than the rated performance of many ERVs on the market (near 120 cfm). A key reason for this is that the VICS core is substantially larger than heat exchangers in most devices delivering flow rates near 120 cfm. Table 17 summarizes values for equipment rated through the Home Ventilated Institute (HVI) at flow rates near 120 cfm (HVI 2019). It is important to note that the HVI values are for entire pieces of equipment—not the cores alone. Sensible recovery efficiency and total recovery efficiency account for air transfer, leakage, conductance through the housing, fan energy, and other gains and losses. By necessity, efficiency of an appliance is somewhat less than the effectiveness of the core. Conditions for the values in Table 17 are summarized in Table 18.

**Table 17. Average and Maximum HVI Rated Performance**

| Rated ERV   | Flow Rate [cfm] | Sensible Recovery Efficiency | Total Recovery Efficiency |
|-------------|-----------------|------------------------------|---------------------------|
| HVI Average | 100–130         | 68%                          | 45%                       |
| HVI Maximum | 100–130         | 76%                          | 48%                       |

**Table 18. CSA 439 and HVI Test Conditions**

|                     | Outdoor Conditions | Indoor Conditions |
|---------------------|--------------------|-------------------|
| Winter/Heating Mode | 32°F, 75% RH       | 71.6°F, 40%RH     |
| Summer/Cooling Mode | 95°F, 50% RH       | 75.2°F, 50% RH    |

### 6.2.3 Power

The large core and 140-mm blowers result in much lower power consumption (35–40 W at 120 cfm) than other ERVs in this flow range. If power consumption of the AHU is added (30–35 W in the system tested), total power is comparable to many efficient ERVs. Figure 45 shows the measured VICS power consumption along with commercially available products in the HVI database (HVI 2019). The box plot shows the mean, 25%, and 75% power values for the same

airflow range. The chart also shows power consumption of three ERVs that SWA often recommends or encounters in high-performance homes. The VICS power values in Figure 45 do not include AHU power (30–35 W with the Mitsubishi AHU used in prototype testing).

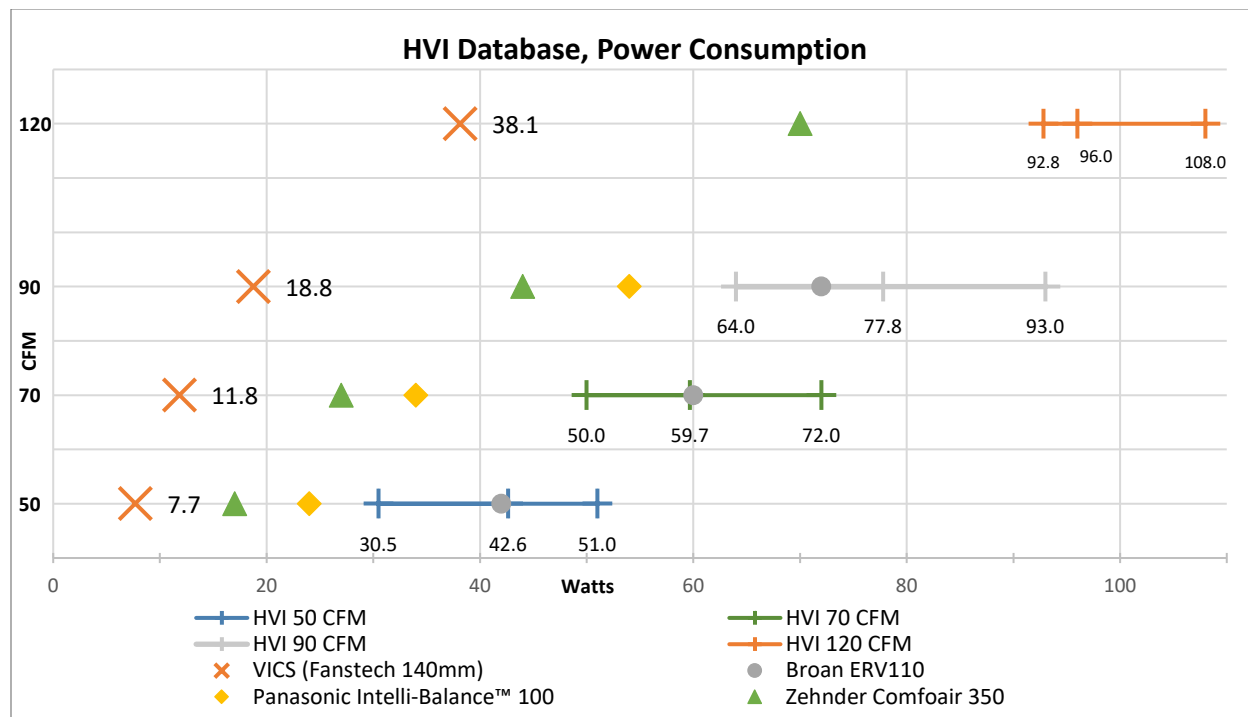

Figure 45. VICS power at several flow rates compared to commercially available ERVs

As discussed (Section 6.2.2), SWA believes that a CORE Mustang ERV core with 2.0-mm spacing would be more appropriate than the 2.4-mm spacing tested. The tighter spacing comes with a higher pressure drop, of course, and likely a power premium of 8 W at 120 cfm. SWA believes this is worthwhile for the significant gains in recovery effectiveness.

### 6.2.4 Cost

Because a commercial product does not yet exist, cost and prices are not known exactly. In discussions with component suppliers and Therma-Stor, SWA believes a retail price will be approximately \$1,500, with an installed cost of approximately \$2,000. This retail price is higher than many efficient ERVs, but the installed cost will be comparable (or lower).

## 6.3 Market Potential

One of the first tasks in this project (Milestone 2.1.1) was interviewing builders and developers about the use of heat/energy recovery ventilation in residential buildings (both single-family and multifamily). Overall, those interviewed thought that energy recovery ventilation was too expensive, that energy savings do not justify the cost, and that there are a host of other challenges related to installation, access, additional wall penetrations, maintenance, etc. Overall, developers noted many fewer benefits than challenges with ERVs, and the primary reason they would consider installing such systems would be if codes and/or green building programs

required them. The predominant opinion, however, was that codes and programs would likely be moving in this direction in the near future.

The survey described in Section 5 (conducted nearly three years later) shows very different responses: most of the respondents use H/ERVs regularly in their residential projects (see Figure 35). This survey certainly does not reflect the industry as a whole; the 96 respondents were a self-selecting group who were interested enough to complete a 5–10 minute survey. SWA believes the survey does reflect some likely early adopters of a commercial VICS product.

The installed cost goal for the VICS (\$2,000) is very much in line with the installed costs shown in the survey results (Figure 42). In SWA’s experience, currently available ERVs with thermal and electric efficiencies near that of the VICS have list prices starting at \$800–\$1,000 (some prices are much higher). More than 40% of the respondents said that the typical installed cost of ERVs is above \$2,000 per dwelling unit.

To assess larger market potential, SWA obtained a market study for North American HRV and ERV sales (Markets and Markets 2019). Figure 46 shows modest growth in sales of approximately 10% per year, and this trend is predicted to continue to 2022. Residential ERV sales in Canada were 66% of U.S. sales (with population approximately 11% of the United States). This reflects varying regulations as well as greater energy saving potential of ERVs in colder climates. The VICS is only appropriate for homes with small heating and cooling loads (likely design loads of 24,000 Btu/h and lower) and with small-capacity, efficient, forced-air heating and cooling systems. In new construction such systems are becoming more common—especially in multifamily and attached single-family housing.

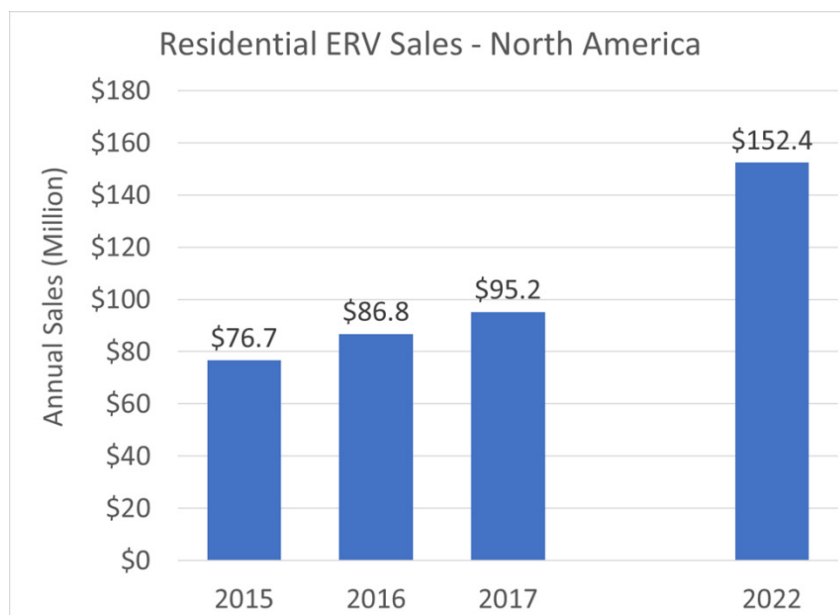

Figure 46. Residential H/ERV sales history and forecast

## 6.4 Next Steps

Based on the prototype testing described here, the team has redesigned the system with several improvements:

- Better insulation; thermal bridging eliminated/reduced
- Blowers mounted orthogonally
- Can be paired with AHUs up to 2-ton capacity (800–900 cfm)
- Different core to boost both total and sensible effectiveness
- Lower height
- Better integration of frost-prevention damper.

Details of this design are not presented here because they may be proprietary. SWA has applied for patents on the technology concept; U.S. and Canadian utility patent applications for the VICS were published on February 28, 2019 (US20190063780A1, CA3014479A1). Therma-Stor has expressed some interest in commercializing the product, but the likely next step is pilot demonstrations in several homes (approximately 4–6 homes). SWA has received some interested from designers and developers looking to install and evaluate a prototype.

A pilot prototype will also be evaluated in test chambers to document performance under defined, steady-state conditions. Chamber tests can predict (and perhaps refine) system performance when tested for product certification. Rating tests will be conducted per C439-18 (CSA 2018), which is the basis for HVI listing and the Canadian ENERGY STAR label for ERVs (NRCAN 2015). The two major Passive House organizations in the United States (PHIUS: Passive House Institute U.S. and PHI: Passive House Institute or Passivhaus Institut) also have ERV certification requirements. PHIUS certification requirements (PHIUS 2017) are based largely on C439 and AHRI standards (AHRI 2014). PHI testing and rating requirements are quite different (PHI 2016), but planning for testing and certification under this standard is also likely worthwhile. More Passive House buildings are being built (with both certifications), and H/ERVs are absolutely required in these buildings. SWA and Therma-Stor are discussing funding and cost-sharing options for performing this next stage of product development, evaluation, and testing.

## References

- ACCA. 2014. *Manual S, Residential Equipment Selection*. Second Edition. Arlington, VA: Air Conditioning Contractors of America.
- ACCA. 2016. *Residential Load Calculation Manual J*. Eighth Edition. Arlington, VA: Air Conditioning Contractors of America.
- AHRI. 2014. *Performance Rating of Air-to-Air Exchangers for Energy Recovery Ventilation Equipment*. ANSI/AHRI Standard 1060. Arlington, VA: Air-Conditioning, Heating, and Refrigeration Institute.
- ASHRAE. 2013. ANSI/ASHRAE Standard 62.2-2013 - Ventilation and Acceptable Indoor Air Quality in Low-Rise Residential Buildings. Atlanta, GA: ASHRAE.
- ASHRAE. 2017. *ASHRAE Handbook: Fundamentals*. Atlanta, GA: ASHRAE.
- Cadmus. 2016. “Ductless Mini-Split Heat Pump Impact Evaluation.” Waltham, MA: The Cadmus Group. <http://www.ripuc.ri.gov/eventsactions/docket/4755-TRM-DMSHP%20Evaluation%20Report%2012-30-2016.pdf>.
- Cadmus. 2017. “Evaluation of Cold Climate Heat Pumps in Vermont.” Waltham, MA: The Cadmus Group. [https://publicservice.vermont.gov/sites/dps/files/documents/Energy\\_Efficiency/Reports/Evaluation%20of%20Cold%20Climate%20Heat%20Pumps%20in%20Vermont.pdf](https://publicservice.vermont.gov/sites/dps/files/documents/Energy_Efficiency/Reports/Evaluation%20of%20Cold%20Climate%20Heat%20Pumps%20in%20Vermont.pdf).
- CSA. 2018. “Laboratory methods of test for rating the performance of heat/energy-recovery ventilators.” C439-18. Toronto, ON: CSA Group.
- DOE. 2015. *Building America Research-to-Market Plan*. Washington, DC: U.S. Department of Energy. <https://www.energy.gov/eere/buildings/downloads/building-america-program-research-market-plan>.
- DOE. 2019. *DOE Zero Energy Ready Home National Program Requirements (Rev. 07)*. Washington, DC: U.S. Department of Energy. <https://www.energy.gov/sites/prod/files/2019/04/f62/DOE%20ZERH%20Specs%20Rev07.pdf>.
- Harriman, L., B. Stephens, and T. Brennan. 2019. “New Guidance for Residential Air Cleaners.” ASHRAE Journal. September 2019.
- Harvard. 2013. “A Summary of Error Propagation.” Cambridge, MA: Harvard Instructional Physics Laboratory. [http://ipl.physics.harvard.edu/wp-uploads/2013/03/PS3\\_Error\\_Propagation\\_sp13.pdf](http://ipl.physics.harvard.edu/wp-uploads/2013/03/PS3_Error_Propagation_sp13.pdf).



Holladay. 2012. “Are HRVs Cost-Effective?” Green Building Advisor. Newtown, CT: The Taunton Press, Inc. <https://www.greenbuildingadvisor.com/article/are-hrvs-cost-effective>.

HVI. 2019. Certified Home Ventilating Products Directory. HVI Publication 911. Cheyenne, WY: Home Ventilating Institute. <https://www.hvi.org/hvi-certified-products-directory/section-iii-hrv-erv-directory-listing/>.

Markets and Markets. 2019. Energy Recovery Ventilator Market – Global Forecast to 2022.

NRCAN. 2015. ENERGY STAR® Technical Specifications for Residential Heat-Recovery Ventilators and Energy-Recovery Ventilators (H/ERVs) Version 2.0. Ottawa, ON: Natural Resources Canada. <https://www.nrcan.gc.ca/sites/www.nrcan.gc.ca/files/oeefiles/pdf/residential/manufacturers/specifications/pdf/HRV-ENERGY-STAR-Specifications-Version-2-0-FINAL-EN.PDF>.

PHI. 2016. “Requirements and testing procedures for energetic and acoustical assessment of Passive House ventilation systems < 600 m<sup>3</sup>/h for Certification as ‘Passive House suitable component.’” Darmstadt, Germany: Passivhaus Institut. [https://passiv.de/downloads/03\\_Reqs\\_and\\_testing\\_procedures\\_ventilation\\_en.pdf](https://passiv.de/downloads/03_Reqs_and_testing_procedures_ventilation_en.pdf).

PHI. 2018. “Criteria for the Passive House, EnerPHit and PHI Low Energy Building Standard.” Darmstadt, Germany: Passivhaus Institut. [https://passipedia.org/\\_media/picopen/9f\\_180112\\_phi\\_building\\_criteria\\_en\\_ip.pdf](https://passipedia.org/_media/picopen/9f_180112_phi_building_criteria_en_ip.pdf).

PHIUS. 2015. “Mechanical Ventilation of High Performance Passive House Buildings in North America.” Chicago, IL: Passive House Institute US.

PHIUS. 2017. “PHIUS HRV/ERV Certification Program.” Chicago, IL: Passive House Institute US. [https://www.phius.org/documents/2017-11-01\\_PHIUS\\_Ventilation\\_HRV\\_ERV\\_certification\\_program\\_v0.7.pdf](https://www.phius.org/documents/2017-11-01_PHIUS_Ventilation_HRV_ERV_certification_program_v0.7.pdf).

PHIUS. 2018. “PHIUS+ 2018 Passive Building Standard.” Chicago, IL: Passive House Institute US.

Puttagunta, S. 2015. *Low-Load Space Conditioning Needs Assessment*. DOE/GO-102015-4670 Washington, DC: U.S. Department of Energy. [https://www1.eere.energy.gov/buildings/publications/pdfs/building\\_america/low-load-space-conditioning-assessment.pdf](https://www1.eere.energy.gov/buildings/publications/pdfs/building_america/low-load-space-conditioning-assessment.pdf).

USGBC. 2013. “LEED v4 for Homes Design and Construction.” Washington DC: United States Green Building Council.

Werling, E. 2015. *Building America Research-to-Market Plan*. DOE-EE 1285. Washington, DC: U.S. Department of Energy.

<https://www.energy.gov/sites/prod/files/2015/11/f27/Building%20America%20Research%20to%20Market%20Plan-111715.pdf>.

Williamson, J., and R. Aldrich. 2015. "Field Performance of Inverter-Driven Heat Pumps in Cold Climates." DOE/GO-102015-4642.

[https://www1.eere.energy.gov/buildings/publications/pdfs/building\\_america/inverter-driven-heat-pumps-cold.pdf](https://www1.eere.energy.gov/buildings/publications/pdfs/building_america/inverter-driven-heat-pumps-cold.pdf).

## Appendix A. Instrumentation

This appendix describes instrumentation used to test the alpha and the beta prototypes. A P2000 programmable logic controller from Automation Direct was used to record sensor values and to implement control algorithms. The device utilized 48 input channels to read different sensor outputs and 24 output channels to control motors and dampers in the VICS. The programmable logic controller reads 0- to 20-mA input signals with 13-bit resolution and outputs 0 to 10 VDC with 12-bit resolution. Additionally, a Campbell Scientific CR1000 datalogger was used in conjunction with 10-k $\Omega$  NTC thermistors to obtain more accurate temperature measurements. Sensor arrays were used where air was not likely to be well mixed (locations 3, 7, and 8 in Figure 49). A list of sensors used during Phase III testing is in Table 19.

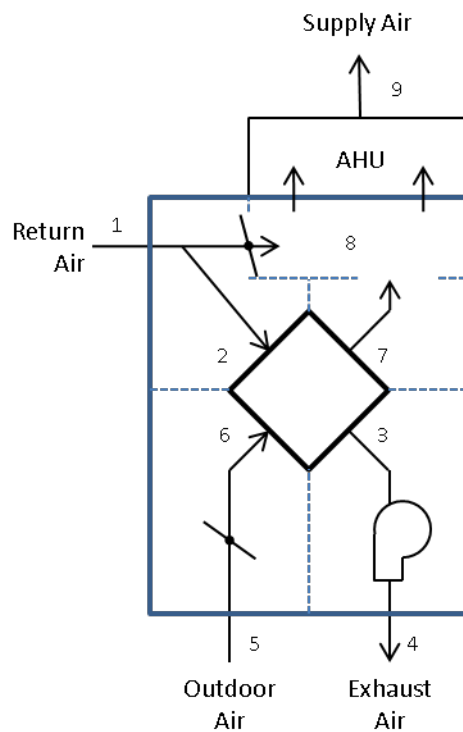

Figure 47. General schematic with measurement locations

**Table 19. Measurement Instruments**

| Measurement                   | Location (Figure 49) | Instrument(s)  | Accuracy   | Qty          |
|-------------------------------|----------------------|--|--|--------------|
| Return/extract air TRH        | 1                    | Temperature/RH (programmable logic controller):<br>Siemens QFM3171<br><br>Temperature (Campbell):<br>Omega 10-kΩ NTC bead thermistor 44031 | Siemens:<br>±0.3–0.8°C<br>±2% RH<br><br>Omega:<br>±0.1°C       | S: 1<br>O: 1 |
| Exhaust air leaving core TRH  | 3                    |  |  | S: -<br>O: 4 |
| Exhaust air after fan TRH     | 4                    |  |  | S: 1<br>O: 1 |
| Outdoor air entering core TRH | 6                    |  |  | S: 1<br>O: 1 |
| Outdoor air leaving core TRH  | 7                    |  |  | S: 2<br>O: 4 |
| Return plenum TRH             | 8                    |  |  | S: 4<br>O: 6 |
| Supply air TRH                | 9                    |  |  | S: 2<br>O: 4 |
| Exhaust airflow rate          | 4                    | Air Monitor LO-Flo 6-in. pitot traverse station with Setra model 2641-0R1WD-11-T1-F (0-0.1 in. w.g.)                                       | ±2% velocity (flow station),<br>±0.00025 in. w.g. (transducer) | 1            |
| Outdoor airflow rate          | 5                    |  |  | 1            |
| Supply airflow rate           | 9                    | Kele FXP-12 measuring station with Setra model 2641-0R1WD-11-T1-F (0-0.1 in. w.g.)   | ±2% velocity (flow probes),<br>±0.00025 in. w.g. (transducer)  | 1            |
| Static pressures              | 2,3,4, 5,6,7,8,9     | Dwyer A-302 pressure probe with Setra pressure transducer model 2641-0R5WD-11-T1-F (0–0.5 in. w.g.)  | ±0.0013 in. w.g. (probe),<br>±0.00025 in. w.g. (transducer)    | 8            |
| Air handler                   | NA                   | CCS WattNode WNC-3D-240-MB with CTT-0300-005 current transducers (5 amp)   | 1% of reading  | 1            |
| Heat pump outdoor unit        | NA                   | CCS WattNode WNC-3D-240-MB with CTT-0300-015 current transducers (15 amp)  | 1% of reading  | 1            |
| Ventilation fans              | NA                   | CCS WattNode WNC-3D-240-MB with CTT-0300-005 current transducers (5 amp)   | 1% of reading  | 1            |



Figure 48. Six thermistors and four TRH sensors were installed to measure properties of the air entering the AHU (location 8 in Figure 47)



Figure 49. Four thermistors and two TRH sensors were installed in each quadrant where air left the ERV core

## Appendix B. Calculations

Sensible heating or cooling output of the heat pump was calculated continuously as follows:

$$\dot{Q}_{\text{sens}} = \dot{V} \rho c_p (T_{\text{SA}} - T_{\text{MA}}) \times 60 \text{ min/h}$$

Where:

$\dot{Q}_{\text{sens}}$  = Sensible heat delivered (or removed) by heat pump (Btu/h)

$\dot{V}$  = Airflow rate (ft<sup>3</sup>/min) through the fan coil

$\rho$  = Air density (lbm/ft<sup>3</sup>), calculated at temperature of flow measurement

$c_p$  = Air heat capacity (Btu/lbm°F)

$T_{\text{SA}}$  = Temperature (dry bulb) of supply air (°F)

$T_{\text{MA}}$  = Temperature (dry bulb) of mixed return air and tempered outdoor air (°F)

During cooling operation, total capacity was calculated as:

$$\dot{Q}_{\text{tot}} = \dot{V} \rho (h_{\text{SA}} - h_{\text{MA}}) \times 60 \text{ min/h}$$

Where:

$\dot{Q}_{\text{tot}}$  = Total heat removed by the heat pump (Btu/h)

$h_{\text{SA}}$  = enthalpy of supply air (Btu/lbm)

$h_{\text{MA}}$  = enthalpy of mixed air (Btu/lbm)

Heat pump COPs were calculated during given test intervals as:

$$\text{COP} = \frac{Q}{E \times 3.412 \text{ Btu/Wh}}$$

Where:

COP = coefficient of performance

Q = Total heat supplied or removed during test (Btu)

E = Electric energy consumed by outdoor unit and fan coil during test (Wh)

With all heat recovery tests, SWA calculated sensible and total heat recovery effectiveness as follows. These equations are identical to those in ANSI/AHRI Standard 1060 Appendix C (AHRI 2014).

$$\varepsilon_{\text{sens}} = \frac{\dot{m} c_{p,\text{OA}} (T_{\text{TA}} - T_{\text{OA}})}{\dot{m} c_{p,\text{min}} (T_{\text{RA}} - T_{\text{OA}})}$$

Where:

$\varepsilon_{\text{sens}}$  = Sensible heat exchanger effectiveness

$\dot{m}c_{p,OA}$  = Mass flow rate times heat capacity of outdoor air (Btu/min°F)

$\dot{m}c_{p,min}$  = Mass flow rate times heat capacity, minimum of outdoor air and exhaust air (Btu/min°F)

$T_{TA}$  = Temperature (dry bulb) of tempered air leaving the heat exchanger (°F)

$T_{OA}$  = Temperature (dry bulb) of outdoor air (°F)

$T_{RA}$  = Temperature (dry bulb) of return air (°F)

$$\epsilon_{tot} = \frac{\dot{m}_{OA}(h_{TA} - h_{OA})}{\dot{m}_{min}(h_{RA} - h_{OA})}$$

Where:

$\epsilon_{tot}$  = Total heat exchanger effectiveness

$\dot{m}_{OA}$  = Mass flow rate of outdoor air (lbm/min)

$\dot{m}_{min}$  = Mass flow rate, minimum of outdoor air and exhaust air (lbm/min)

$h_{TA}$  = Enthalpy of tempered air leaving the heat exchanger (Btu/lbm)

$h_{OA}$  = Enthalpy of outdoor air (Btu/lbm)

$h_{RA}$  = Enthalpy of return air (Btu/lbm)

## Appendix C. Propagation of Uncertainty

Sensor accuracies can compound quickly when calculations involve multiple variables, low flow rates, and modest temperature (or enthalpy) differentials. Instrument accuracies were listed in Table 19. Table 20 outlines measured values from one example, and provides an example calculation of ERV sensible effectiveness uncertainty (Table 21).

**Table 20. Example Readings and Uncertainty Values from a Cooling Season Test**

| Variable                      | Value     | Uncertainty ( $\delta$ )                        |
|-------------------------------|-----------|---|
| Ventilation Flow              | 123.2 cfm | $\pm 12.3$                                      |
| Exhaust Flow                  | 123.2 cfm | $\pm 12.3$                                      |
| Outdoor Air (OA) Temperature  | 80.1°F    | $\pm 0.1^\circ\text{C}, \pm 0.18^\circ\text{F}$ |
| Outdoor Air (OA) RH           | 64%       | $\pm 2\%$                                       |
| Tempered Air (TA) Temperature | 76.9°     | $\pm 0.36^\circ\text{F}$                        |
| Tempered Air (TA) RH          | 59%       | $\pm 3\%$                                       |
| Return Air (RA) Temperature   | 75.3°F    | $\pm 0.1^\circ\text{C}, \pm 0.18^\circ\text{F}$ |
| Return Air (RA) RH            | 45%       | $\pm 2\%$                                       |

The temperature and RH of the air leaving the core (TA) was measured using four temperature and two humidity sensors. The error propagation for a sum of uncertainties was calculated as follows (Harvard 2013).

$$\delta_{T_{TA}} = \sqrt{\delta_1^2 + \delta_2^2 + \delta_4^2 + \delta_4^2} = \sqrt{.18^2 + .18^2 + .18^2 + .18^2} = \pm 0.36^\circ\text{F}$$

$$\delta_{RH_{TA}} = \sqrt{\delta_1^2 + \delta_2^2} = \sqrt{.02^2 + .02^2} = \pm 3\% \text{ RH}$$

*Note: There is a slight temperature gradient across the face of the core; therefore, the T and RH probes are considered to be measuring independent variables. If the air was well mixed and uniform temp/RH, the sensor readings would be treated as an average. The uncertainties would then be divided by the number of measurements, ex.  $\delta_T = 0.36/4 = \pm 0.09^\circ\text{F}$ ,  $\delta_{RH} = 0.03/2 = \pm 1.5\% \text{ RH}$ .*

The flow rate is based on a velocity pressure reading; the pressure transducer accuracy is  $\pm 0.00025$  in. w.g.; therefore, through a 6-in. duct, our flow measurement inaccuracy is:

$$\text{Flow} = \text{Area} [ft^2] * K_p * \sqrt{\Delta P [in. w. g.]}$$

$$\delta_{flow} = 0.194 ft^2 * 4005 * \sqrt{0.00025 in. w. g.} = \pm 12.3 \text{ CFM}$$

Air density is calculated as a function of temperature, humidity, and elevation (ASHRAE 2017). Standard airflow rate (scfm) is calculated as follows:



$$SCFM = CFM * \frac{\rho(T, RH, Elevation)}{\rho_{std}}$$

Where  $\rho_{std} = 0.075 \text{ lbm/ft}^3$

In order to calculate the uncertainty of a multivariate function such as density, the following method is typically used:

$$q(a, b, c) = z, \quad \delta_q = \sqrt{\left(\frac{\partial q}{\partial a} \delta a\right)^2 + \left(\frac{\partial q}{\partial b} \delta b\right)^2 + \left(\frac{\partial q}{\partial c} \delta c\right)^2}$$

However, SWA surmised that such rigorous analysis for a small conversion (cfm to scfm) would likely not be necessary. SWA based standard flow uncertainties on root sum of squares of relative uncertainties of the three variables. The equation below shows that uncertainty in the flow measurement dominates; the relative uncertainty in scfm (10.5%) is only slightly higher than the relative uncertainty in cfm (10.0%). The impact of temperature on scfm uncertainty is negligible, and the impact of RH in this simplified calculation is exaggerated.

$$\frac{\delta_{scfm}}{scfm} = \sqrt{\left(\frac{\delta_{rh}}{rh}\right)^2 + \left(\frac{\delta_{CFM}}{CFM}\right)^2 + \left(\frac{\delta_T}{T_{abs}}\right)^2} = \sqrt{\left(\frac{0.02}{0.64}\right)^2 + \left(\frac{12.3}{123.2}\right)^2 + \left(\frac{0.2}{538.8}\right)^2} = 10.5\%$$

To check this assumption, SWA calculated “worst-case” values for scfm of outdoor air based on extreme errors using the values from Table 20.

Flow:  $123.2 \pm 12.3 \text{ cfm}$

Outdoor Air Temp:  $80.1 \pm 0.18^\circ\text{F}$

Outdoor Air RH:  $64 \pm 2\%$

$$\text{Standard Flow} = 123.2 \text{ CFM} * \frac{\rho(80.1^\circ\text{F}, 64\% \text{ RH})}{\rho_{std}} = 119.7 \text{ SCFM}$$

$$\delta_{scfm} = 10.5\% * 119.7 \text{ SCFM} = 12.6 \text{ scfm}$$

Scfm was calculated assuming all sensors err toward high flow and high density:

$$135.5 \text{ CFM} * \frac{\rho(79.9^\circ\text{F}, 62\% \text{ RH})}{\rho_{std}} = 131.7 \text{ SCFM}$$

Scfm was also calculated assuming all sensors err toward low flow and low density:

$$110.9 \text{ CFM} * \frac{\rho(80.3^\circ\text{F}, 66\% \text{ RH})}{\rho_{std}} = 107.7 \text{ SCFM}$$

These worst-case values provide  $\pm 12 \text{ scfm}$ , showing that the earlier simplification of  $\pm 12.6 \text{ scfm}$  is reasonable or even somewhat conservative. With the scfm uncertainty calculated, we can then calculate the heat transfer across the intake path of the core:

$$Q_{sens TA-OA} = scfm_{OA} * \rho c_p (\Delta T_{TA-OA}) * 60 \frac{min}{h}$$

$$Standard Conditions: \rho = 0.075 \frac{lb}{ft^3} \quad c_p = 0.24 \frac{btu/lb}{^\circ F}$$

Temperature differential and uncertainty in the temperature differential are calculated as follows:

$$\Delta T_{TA-OA} = |76.9 - 80.1| = 3.2^\circ F$$

$$\delta_{\Delta T} = \sqrt{\delta_{TA}^2 + \delta_{TO}^2} = \sqrt{0.36^2 + 0.18^2} = \pm 0.4^\circ F$$

The relative uncertainty in heat transfer is then calculated as the root sum of squares of the relative uncertainties of temperature differential and standard airflow.

$$\frac{\delta_{Q_{sens TA-OA}}}{Q_{sens TA-OA}} = \sqrt{\left(\frac{\delta_{\Delta T}}{\Delta T}\right)^2 + \left(\frac{\delta_{scfm_{OA}}}{SCFM}\right)^2} = \sqrt{\left(\frac{0.4}{3.2}\right)^2 + \left(\frac{12.6}{119.7}\right)^2} = 16.3\%$$

$$Q_{sens TA-OA} = 414 \pm 68 Btu/h$$

The same process was repeated for the denominator of the effectiveness equation:

$$Q_{min,sens RA-OA} = 621 \pm 72 Btu/h$$

Now we are able to calculate the uncertainty of our sensible effectiveness:

$$\frac{\delta_{\epsilon_{sens}}}{\epsilon_{sens}} = \sqrt{\left(\frac{\delta_{Q_{sens TA-OA}}}{Q_{sens TA-OA}}\right)^2 + \left(\frac{\delta_{Q_{min,sens RA-OA}}}{Q_{min,sens RA-OA}}\right)^2} = \sqrt{\left(\frac{68}{414}\right)^2 + \left(\frac{72}{621}\right)^2} = 20.1\%$$

The end result for the sensible effectiveness is:

$$\epsilon_{sens} = \frac{421 Btu/h}{621 Btu/h} = 0.67 \pm 0.13$$

These large uncertainties are unavoidable when calculations are based off of multiple sensor readings. Smaller values such as a low flow rate or small temperature delta across the ERV core result in large relative uncertainties, which propagate and compound throughout calculations. To minimize these uncertainties, SWA attempted to test the ERV core with high temperature and/or enthalpy differentials. Table 21 shows a summary of calculated uncertainty values for this example test.

**Table 21. Example Values and Uncertainties From a Ventilation-Only Test**

| <b>Flow</b>          | <b>SCFM</b>                                   | <b><math>\sigma</math> (<math>\pm</math>)</b> | <b><math>\epsilon</math> (%)</b> |  |
|----------------------|---|---|----------------------------------|--|
| OA                   | 120   | 12.5  | 10%                              |  |
| ExA                  | 121   | 12.5  | 10%                              |  |
| SA                   | 299   | 32  | 11%                              |  |
| <b>Power</b>         | <b>Watts</b>                                  | <b><math>\sigma</math> (<math>\pm</math>)</b> | <b><math>\epsilon</math> (%)</b> |  |
| VICS                 | 37.4  | 0.4   | 1%                               |  |
| AHU                  | 36.1  | 0.4   | 1%                               |  |
| OU                   | 2.4   | 0.0   | 1%                               |  |
| Mitsu                | 75.9  | 0.4   | 0%                               |  |
| <b>Eff.</b>          | <b><math>\sigma</math> (<math>\pm</math>)</b> |   | <b><math>\epsilon</math> (%)</b> |  |
| $\epsilon_{sens}$    | 68%   | 13%   | 20%                              |  |
| $\epsilon_{tot}$     | 47%   | 20%   | 43%                              |  |
| <b>Heat Transfer</b> | <b>Btu/h</b>                                  | <b><math>\sigma</math> (<math>\pm</math>)</b> | <b><math>\epsilon</math> (%)</b> |  |
| $Q_{s,c,OA}$         | 422   | 68  | 16%                              |  |
| $Q_{s,c,min}$        | 625   | 73  | 12%                              |  |
| $Q_{s,c,Ex}$         | 358   | 58  | 16%                              |  |
| $Q_{t,c,OA}$         | 1,952   | 764   | 39%                              |  |
| $Q_{t,c,min}$        | 4,125   | 766   | 19%                              |  |
| $Q_{t,c,Ex}$         | 1,684   | 469   | 28%                              |  |
| <b>Temperature</b>   | <b>°F</b>                                     | <b><math>\sigma</math> (<math>\pm</math>)</b> | <b><math>\epsilon</math> (%)</b> |  |
| OA Core              | 80.1  | 0.2   | -                                |  |
| OA Tempered          | 76.9  | 0.4   | -                                |  |
| Mixing Plenum        | 76.1  | 0.8   | -                                |  |
| SA Duct              | 76.2  | 0.4   | -                                |  |
| RA                   | 75.3  | 0.2   | -                                |  |
| ExA Tempered         | 78.0  | 0.4   | -                                |  |
| ExA Outlet           | 78.3  | 0.2   | -                                |  |
| Temp Across Core     | 3.3   | 0.4   | 12%                              |  |
| Temp Across AHU      | 0.9   | 0.9   | 97%                              |  |
| RA - OA INLET        | 4.8   | 0.3   | 5%                               |  |
| <b>RH</b>            | <b>%</b>                                      | <b><math>\sigma</math> (<math>\pm</math>)</b> | <b><math>\epsilon</math> (%)</b> |  |
| OA Inlet             | 64%   | 2%  | 2%                               |  |
| OA Tempered          | 59%   | 3%  | 3%                               |  |
| Mixing Plenum        | 49%   | 4%  | 4%                               |  |
| SA Duct              | 49%   | 3%  | 3%                               |  |
| RA                   | 45%   | 2%  | 2%                               |  |
| ExA Outlet           | 51%   | 2%  | 2%                               |  |
| <b>Enthalpy</b>      | <b>Btu/lbm</b>                                | <b><math>\sigma</math> (<math>\pm</math>)</b> | <b><math>\epsilon</math> (%)</b> |  |
| OA Core              | 34.8  | 1.1   | -                                |  |
| OA Tempered          | 31.2  | 0.9   | -                                |  |
| SA Duct              | 28.7  | 0.8   | -                                |  |
| RA                   | 27.2  | 0.5   | -                                |  |
| ExA Outlet           | 30.3  | 0.6   | -                                |  |
| Mixed                | 28.5  | 1.3   | -                                |  |
| OA Temp - OA Core    | 3.6   | 1.4   | 38%                              |  |
| ExA Temp - RA        | 3.1   | 0.8   | 26%                              |  |
| SA - MA              | -   | -   | -                                |  |
| RA - OA              | 7.7   | 1.2   | 15%                              |  |



U.S. DEPARTMENT OF  
**ENERGY**

Office of  
**ENERGY EFFICIENCY &  
RENEWABLE ENERGY**

For more information, visit: [buildingamerica.gov](http://buildingamerica.gov)

DOE/GO-102021-5491 • April 2021