



CSP Program Summit 2016

# Dish Stirling High Performance Thermal Storage

Sandia National Laboratories  
Chuck Andraka, DMTS

[energy.gov/sunshot](http://energy.gov/sunshot)

Sandia National Laboratories is a multi-program laboratory managed and operated by Sandia Corporation, a wholly owned subsidiary of Lockheed Martin Corporation, for the U.S. Department of Energy's National Nuclear Security Administration under contract DE-AC04-94AL85000. SAND#



# Dish Stirling Technology

- High performance systems
  - Over 31% sunlight to grid efficiency
  - Over 26% annual efficiency
  - High temperature
  - High concentration
- Typically 3-30kWe
  - Potentially off-grid
  - Large power parks proposed for low cost
- Best technology to meet SunShot goal
  - \$0.06/kWh attainable
    - Deployment
    - Supply chain development
    - Design for manufacture
- Needs storage
  - Match demand curves
  - Utilities/PUC's need to "value" evening generation
  - Differentiation



# Project Objectives

---

- Goal:

- Provide a feasible technical solution for 6 hours of storage on large (25kW<sub>e</sub>) dish Stirling systems
- Enable high performance dish Stirling systems to increase capacity into evening hours

- Innovation:

- Dish Stirling systems have demonstrated path to SunShot Cost Goals of 6-8 ¢/kWh, and is further enhanced by storage
- Concepts for dish storage currently pursued are limited to small dish systems with limited time of storage due to weight at focus
- Proposed solution improves system performance, lowers LCOE, and reduces system cost through more efficient structural design
- Focus on “on-dish” high temperature PCM storage

# Technical Approach Overview

- Latent transport and storage system matches Stirling isothermal input
  - High performance latent storage
  - Heat pipe input and output
  - Emphasis on high performance PCM's (metallic)
- Rear-mounted storage and engine
  - Balanced dish
  - Closes pedestal gap allowing efficient structure
  - Leverages Sandia/DOE high performance heat pipe development
- Pumped return negates elevation change issues

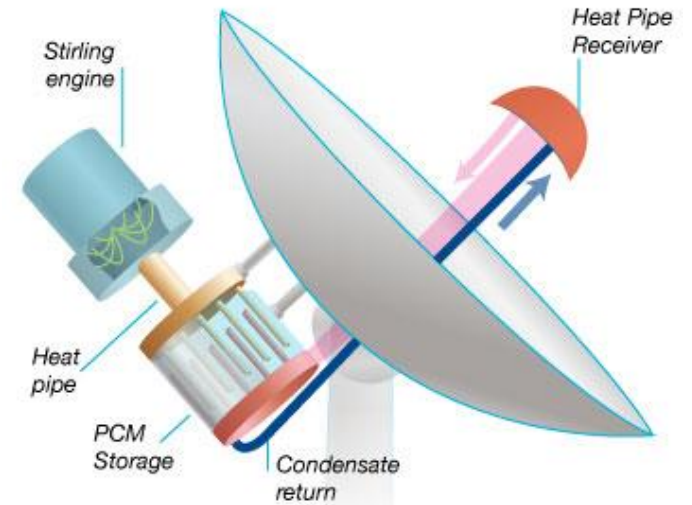

Concept Schematic

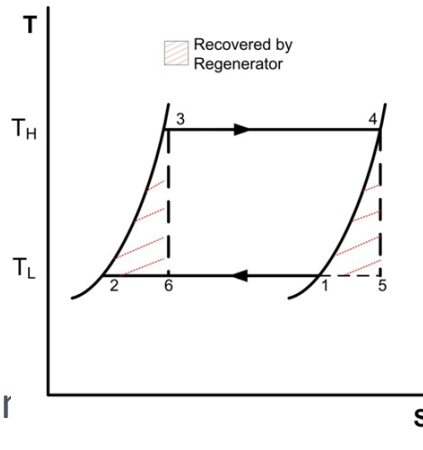

Isothermal input requires latent transport and storage to avoid high exergy losses

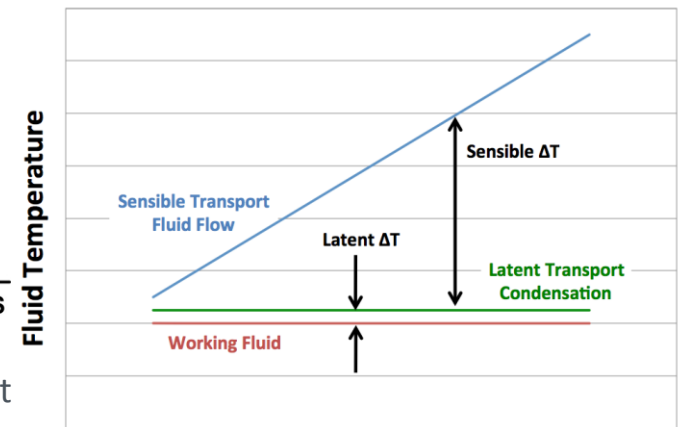

Position in Heat Exchanger

# Key Development Areas

- High performance heat pipe receiver
- Phase change material selection and characterization
- Phase change material compatibility with containment
- System modeling
- Integrated test module

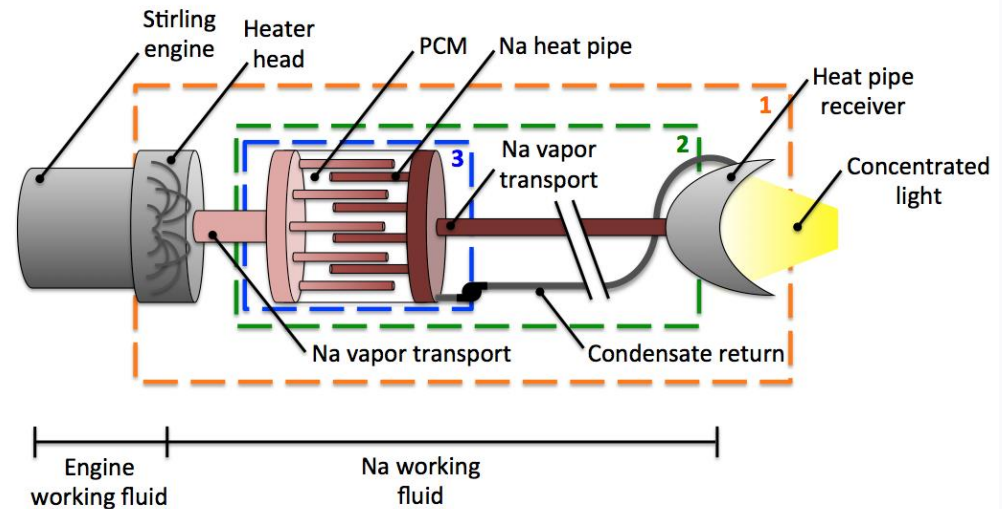

PCM module schematic. Integrated module test would consider Control Volume 3

# Results: High Performance Heat Pipe Receiver

- Robust high performance wick developed
  - Blended fiber and support posts
- Model with measurements indicates 80-100kW<sub>th</sub>
- Bench scale test successful
  - Over 12,000 hours
  - 1.6kW continuous throughput
  - X-ray CT indicates no collapse

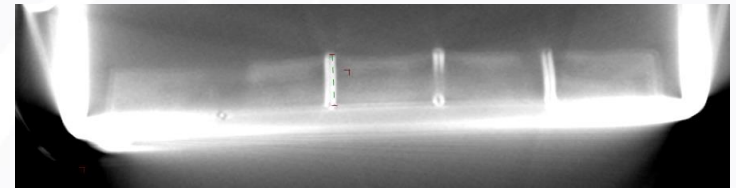

X-Ray CT scan of wick after 5000 hours

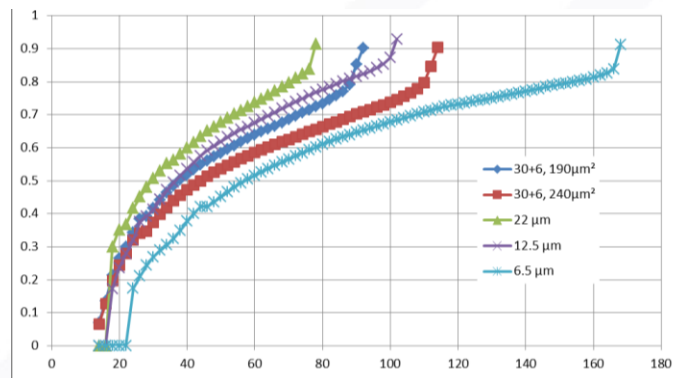

Model results for various wick candidates

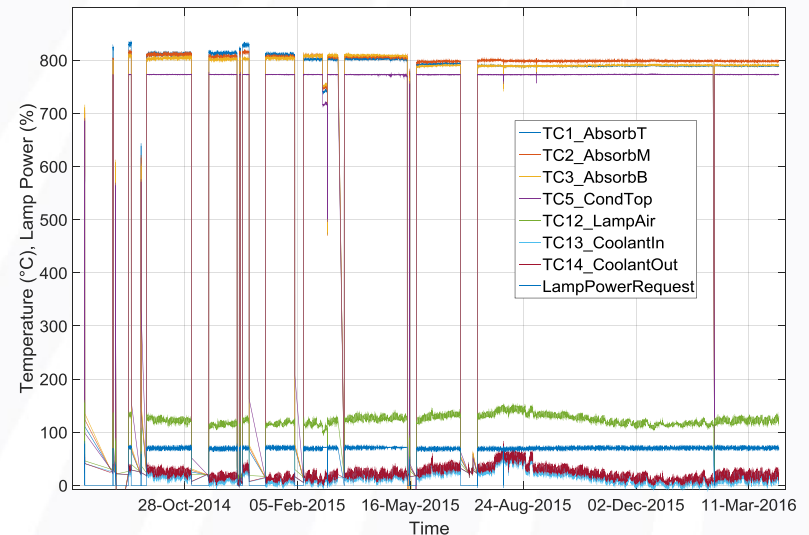

Bench test operational record

# Results: PCM Selection and Characterization

- Modeling led selection of metallic PCM's
- Literature, Factsage, phase diagrams led to final selection
- Ternary metallic per ASM
  - Cu:Mg:Si = 53.5:21.1:25.3 wt%
  - Heat of Melting 462 J/g
  - Consistent cycling in DSC
- Lab samples and large quantities synthesized
- Considerable variation in literature

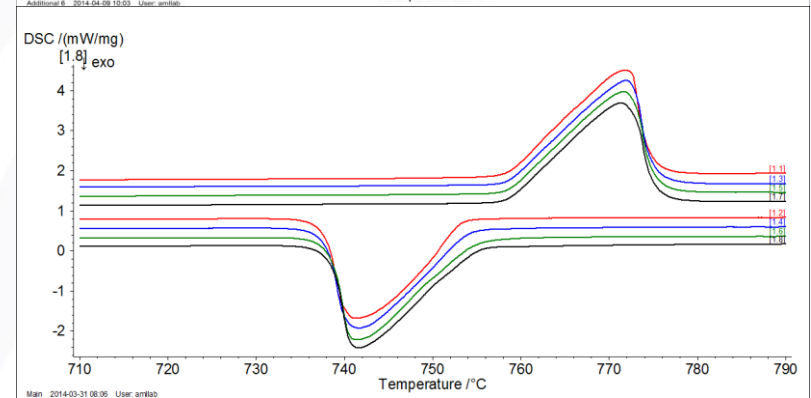
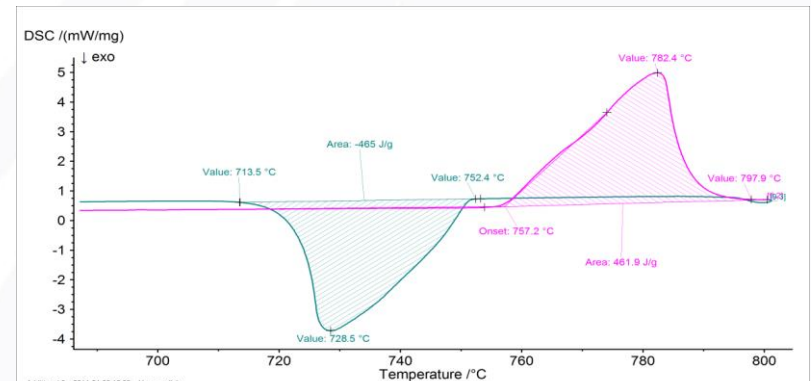
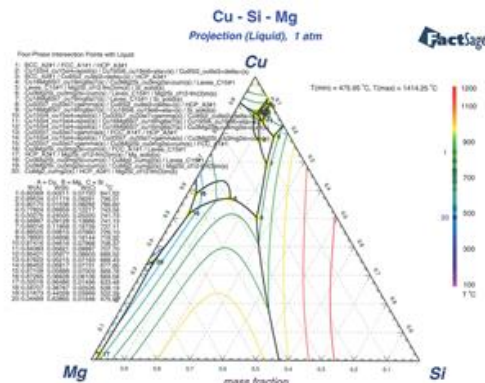

# Results: PCM Compatibility with Containment

- Short-term testing demonstrated acute attack
  - 30% loss of containment in 150 hours
  - 3 containment alloys tested
- Protective coating development
  - Complex geometry limits options
  - Initial focus on solution coatings
  - Later focus on commercial thermal spray
- Approach
  - Identify potential candidates by Gibbs Free Energy
  - Powdered XRD after crucible exposure
  - Sample boat coating exposure
    - Sectioning
    - X-Ray CT scans
- Results
  - $\text{MgAl}_2\text{O}_4$  and  $\text{Al}_2\text{O}_3$  promising
  - Inconsistent vendor-to-vendor results

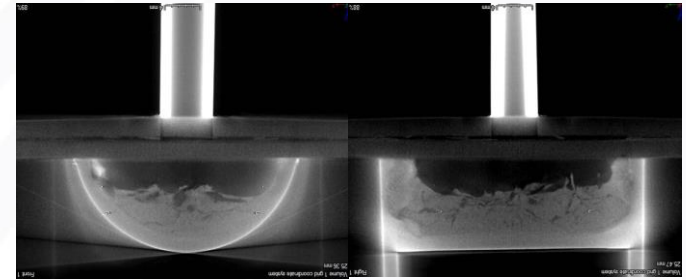

X-Ray CT proved valuable for evaluating closed capsules

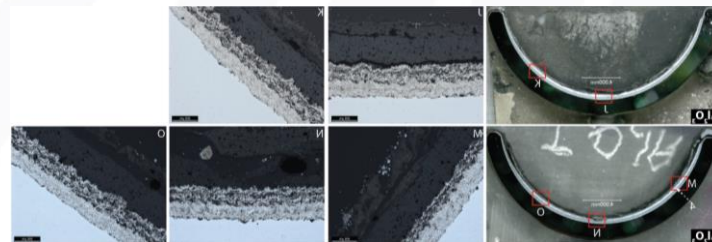

Section of  $\text{Al}_2\text{O}_3$  showing no degradation after 500 hours



# Results: Systems Modeling

- Field level model with shading developed
- LCOE and Profit impacts
  - SCE TOD pricing
  - Vary SM
  - Vary size of storage
- Clear financial benefit
  - Optimum 1.25 SM
  - Significant increase in energy
  - Operational improvements
  - Summer afternoon critical to profit

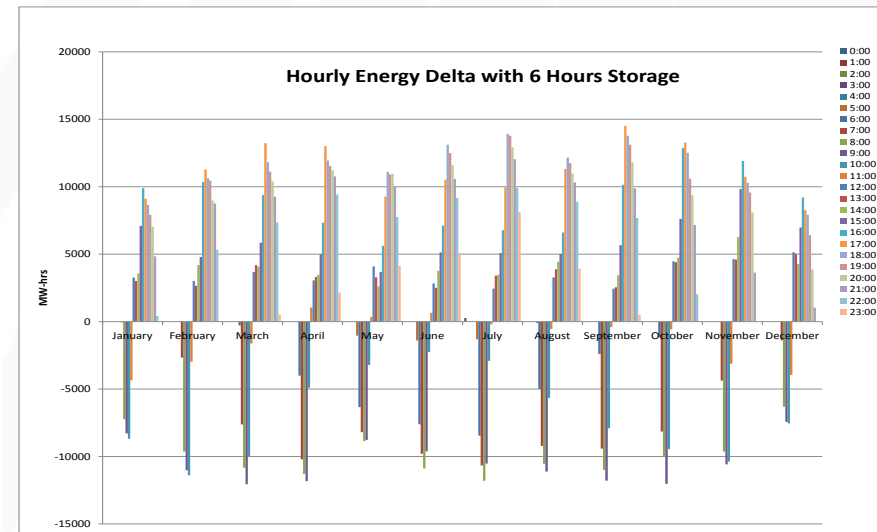
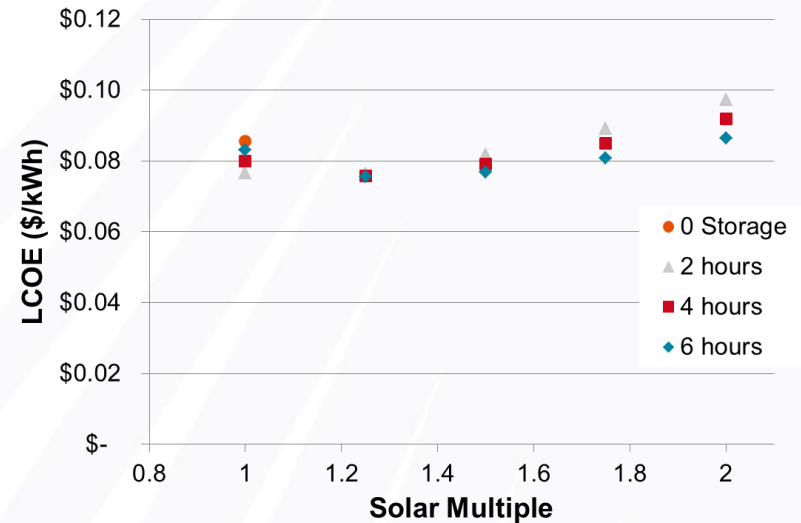

Case	LCOE (\$/kWh)	Profit (\$/kWh)	Cost (\$k/dish)	Cost (\$/kWh <sub>th</sub> )
No Storage	0.086	0.056	0	0
Base	0.076	0.072	21	52
Level LCOE	0.086	0.062	33	82
Level Profit	0.092	0.056	40	99
SunShot	0.06	--	6.5	16

# Results: Integrated Test Module

- 1/10-scale module designed and fabricated
  - Heat pipe input and output
  - Electrically heated
  - Gas gap calorimeter
  - Flange features to protect welds
- Awaiting coating at end of project

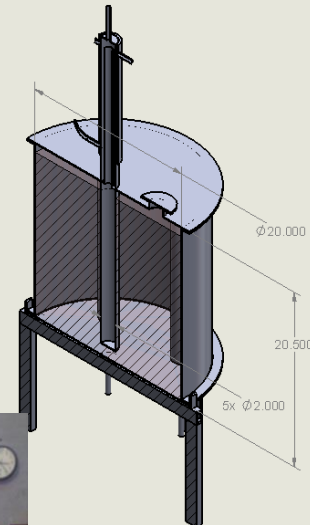

SECTION A-A  
SCALE 1/6

# Summary

---

- Robust heat pipe developed and on test
  - 12000+ hours, 20x prior felt wick heat pipes
  - Application to electronics cooling, tower, other energy systems
- High performance metallic PCM identified
  - Synthesized in significant volumes
  - Useful for isothermal systems up to 800°C
- PCM compatibility coatings
  - Strong candidates need demonstration
  - Alumina
  - Mg Al Spinel
- Analytical demonstration of the value of storage
  - 6 hours “best value”
  - Higher allowable cost than tower systems
- Hardware ready for coating and testing
- Patents and papers