



US-China Clean Energy Research Center Building Energy Efficiency Consortium
Advanced Window and Shading Technologies
2014 Building Technologies Office Peer Review



U.S. DEPARTMENT OF
ENERGY

Energy Efficiency &
Renewable Energy

Eleanor Lee, eslee@lbl.gov
Lawrence Berkeley National Laboratory

Project Summary

Timeline:

Start date: January 2010

Planned end date: December 2015

Key Milestones

1. Develop and evaluate energy impacts of emerging fenestration technologies in LBNL's full-scale outdoor Advanced Windows Testbed, December 2014
2. Evaluate energy use and occupant response in demonstration buildings, March 2015

Budget:

Total DOE \$ to date: \$645K, spent \$300K

Total future DOE \$: \$200K

Target Market/Audience:

Commercial and residential buildings; new or retrofit applications; owners, regulators, utilities, architects, engineers

Key Partners (in-kind funding):

Saint-Gobain	Tongji University
Sage Electrochromics	CABR
Dow Chemical	Chongqing Univ
Lutron	
3M	

Project Goal:

Identify, develop, and promote the use of energy-efficient window and shading technologies that are pragmatic, cost effective, can be broadly and rapidly deployed in residential and commercial buildings throughout China and the US.

Purpose and Objectives

Context: The US-China Clean Energy Research Center Building Energy Efficiency Consortium (CERC-BEE) is a 5-year program focused on real world impact through early commercialization of technologies, software, guidebooks, codes, policies, & more

Problem Statement

- Challenge: 1985-2004: +10 Bm² floor area of new construction in China
- Projected growth in China's building energy use from 5 to 13 Quads between 2005 to 2020, where 50-60% due to HVAC and 20-30% due to lighting energy
- Fenestration systems account for a significant fraction of energy use and peak electric demand in the perimeter zone of buildings, drive HVAC sizing and use, and occupant comfort and satisfaction with the indoor environment.
- Achieving ultra-low energy goals will depend on managing the significant loads that occur through facades and leveraging daylight to offset lighting energy use.

Project Objective

- To identify, develop, and promote the use of energy-efficient window and shading technologies that are pragmatic, cost effective, and can be broadly and rapidly deployed in residential and commercial buildings throughout China and the US.

Purpose and Objectives

Target Market and Audience

- New and retrofit commercial and multi-family residential buildings in China with an existing total energy use of approximately 3-4 Quads (2005)

Impact of Project

- Identification of innovative solar control and daylighting technologies that can provide 40-50% perimeter zone total energy savings compared to GB 50189-2005 while meeting comfort constraints in real world building applications.
- Near-term impact:
 - Monitored evaluation of energy use impacts of automated shading and daylighting systems with occupant response data
 - Promote use of international standards for rating window & shading systems
- Long-term impact
 - Energy use savings of 995 TBtu/yr in 2025 assuming a market adoption rate of 50% of the total 20 Bft²-yr floor area of new and retrofit construction
 - Reduction in CO₂ emissions of 100 Mtons/yr in 2025, assuming a coal/wood fuel source (1 lb of CO₂ generated per 5000 Btu)

Approach

- Benchmark technical potential of dynamic shading and daylighting systems in typical commercial buildings in China using advanced modeling tools
- Develop then verify energy savings and comfort impacts of emerging technologies under real sun and sky conditions using LBNL's full-scale outdoor Advanced Windows Testbed
- Promote market awareness through third-party monitored evaluations of energy use and occupant response in demonstration buildings
- Encourage broader adoption of advanced technologies through demonstrated use of ISO-compliant modeling tools in collaboration with industry, academia, and regulating agencies in China

Approach

Key Issues

- Does taking a whole building integrated approach improve the value proposition of advanced window technologies in the China context
- What is the acceptable balance of tradeoffs between energy-efficiency, indoor environmental quality, and occupant satisfaction and acceptance for advanced window technologies

Distinctive Characteristics

- Advanced modeling tools for optically-complex, light-scattering fenestration systems
- Extensive laboratory and field measurement capabilities
- Unique knowledge of state-of-the-art fenestration technologies

Benchmarking technical potential

Objective: Benchmark energy savings potential of advanced fenestration systems

Accomplishments

- **Near term solutions:** Spectrally-selective low-e windows can reduce sensible cooling and heating loads* by 30-50% in northern climates compared to GB50189-2005 code. [A]
- **Ultra-low energy use solutions:** operable exterior shading or equivalent can reduce sensible cooling and heating loads in all climates to a level equivalent to an opaque wall and increase comfort. [B] → Perimeter zone annual energy use can be reduced by 50-80% with a simple payback of 2-6 years for typical commercial office buildings in China, more if daylighting is included.

* Loads can be more indicative of actual HVAC energy performance since buildings in China are traditionally conditioned on demand.

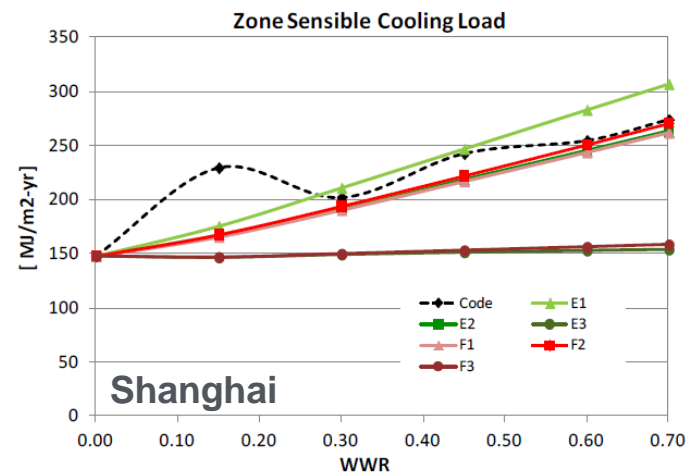
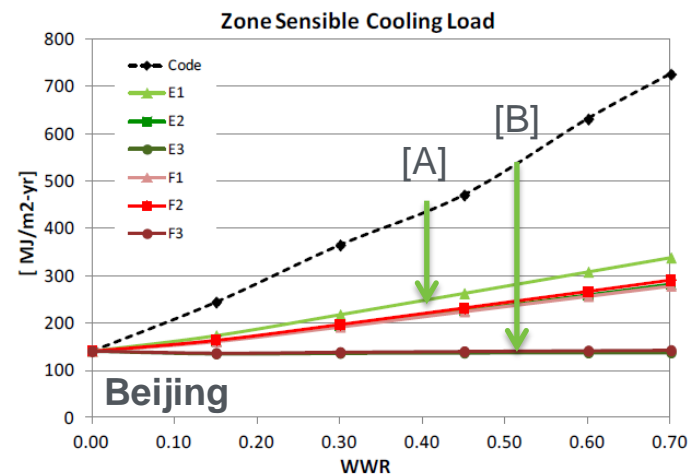

EnergyPlus results from Phase I study

Characterization and modeling tools

Rating and labeling of windows and shading systems

- Training, webinars, workshops, tutorials, and technical papers shared with academia, MoHURD, and industry
- Chinese version of LBNL's WINDOW 6 software rewritten in collaboration with LBNL

Accomplishments

- MoHURD agreed to begin to adopt ISO 15099 (implemented in WINDOW 6), October 2010
- All 8 Chinese glazing manufacturers now contributing to LBNL International Glazing Database (IGDB); training has led to improved quality of measured data from glazing manufacturers
- WINDOW 6 (called "MQMC") software now being sold by Guangdong (PABR)
- Increased awareness of optically complex fenestration modeling tools for shading & daylighting systems



图 D.0.4 横百叶挡板式外遮阳的特征值



图 D.0.5 竖百叶挡板式外遮阳的特征值

表 D.0.1 外遮阳系数计算用的拟合系数 a,b

DGJ08-107-20 Shanghai Standard

Field testing: Automated shading and electrochromic windows

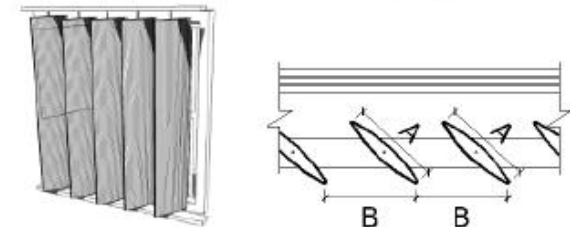
LBL Advanced Windows Testbed field tests

- Saint-Gobain/ Sage Electrochromic windows or Lutron automated indoor roller shades
- April through December 2014 monitored field test

Objectives

- Evaluate vendors' next-generation control algorithms with focus on daylight/ glare control → high dynamic range luminance imaging
- Measure impact of controls on lighting and HVAC energy use

Anticipated Outcomes

- Possible improvements in sensors and control systems for dynamic façade technologies
- Increased confidence in use of technologies in China demonstration projects

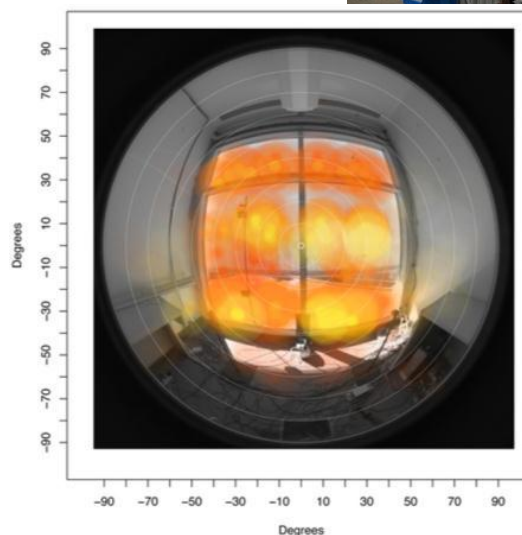

Testbed exterior with EC windows (above)
Time-lapsed field measurements of glare in LBNL windows testbed (left)

Field testing: Integrated dynamic façade systems

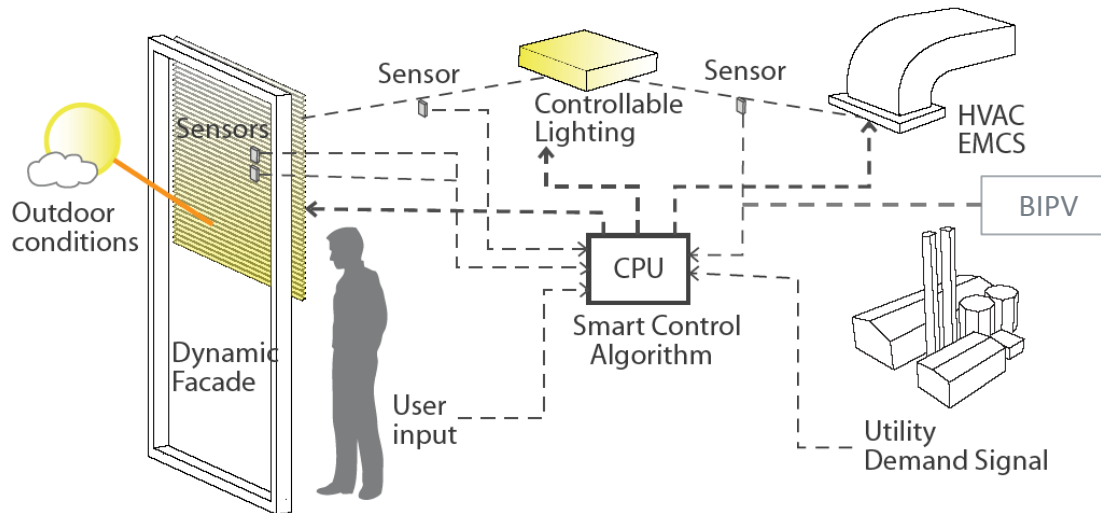

LBL Advanced Windows Testbed field test

- Electrochromic windows or automated indoor roller shades, LED dimmable lighting, 24 V dc network, photovoltaics, battery storage
- Proof-of-concept demand-supply side optimization controller
- June through December 2014 monitored field test

Objectives and anticipated outcomes

- Evaluate feasibility and energy and cost savings potential of very low energy, building-to-grid integrated control system
- Increased value proposition for advanced integrated systems; possible use in Xingye demonstration building

Demonstration: Saint-Gobain Research Shanghai Center

Electrochromic Windows

Demonstration building

- In 2013, developed details of test room construction, equipment, controls, monitoring protocol, instrumentation, human subjects survey, simulation models with Tongji and Saint-Gobain
- SGRS new building completed Dec 2013, move-in Feb 2014, initiated baselining, March 2014, EC installed in April 2014
- Monitoring through April 2015
 - HVAC and thermal comfort assessment
 - Daylighting and lighting energy use
 - Occupant response studies (quarterly)

Anticipated outcomes

- Assessment of end user satisfaction and comfort (thermal and visual) under realistic operating conditions in typical office building



SGRS conference room layout with south-facing windows

Development/ demonstration: Daylight redirecting films

Objective: develop and deploy technologies that can redirect sunlight 30-40 ft from the window; reduce lighting energy use significantly in core zones

Design development (Dow Chemical)

- Characterization and modeling of microprismatic films using scanning goniophotometer and Radiance simulation tools; demonstration of virtual prototyping tools

Demonstration (3M)

- Planned installation in CABR building, Beijing
- Measure daylight, visual comfort, and energy savings potential in a typical office area
- Potential outcome: Increased awareness and adoption of the technology

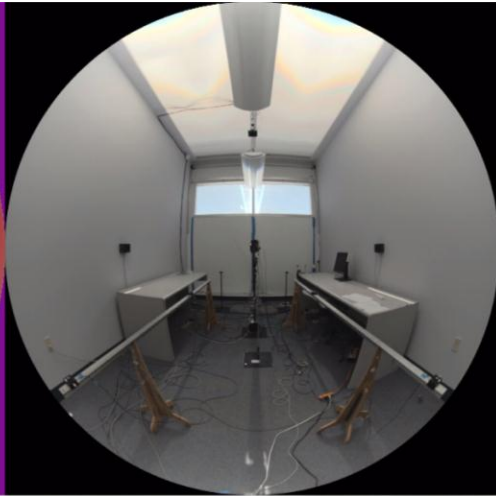
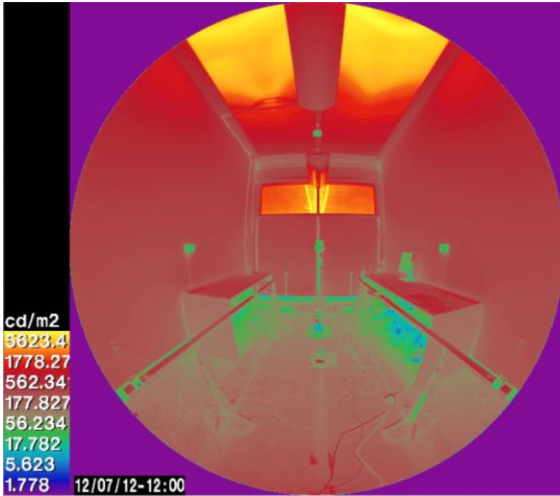
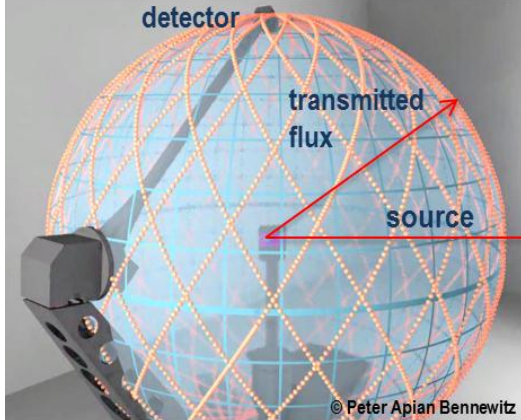
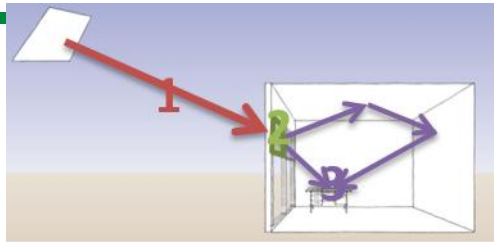

Project Integration and Collaboration

Project Integration

- Industry partners contribute in-kind technical expertise, knowledge about the China market, and products for testing.
- Collaborations with academics and research organizations provide opportunities to share knowledge about modeling tools, experimental methods, technologies, buildings industry, occupant behavior, regulations, etc.

Partners, Subcontractors, and Collaborators

- Industry partners: Saint-Gobain/ Sage Electrochromics, 3M, Lutron Electronics, Dow Chemical, Xingye Solar
- Tongji University, Chongqing University, CABR, Wuhan University of Technology, Zhuhai Singye Green Building Technology Co.

Communications

- CERC-BEE Workshop, Tsinghua University, Beijing, March 23-24, 2011
- Saint-Gobain Research Center Seminar with Tongji Univ, Shanghai, March 5, 2012
- CERC-BEE Annual Meeting, Sanya, Hainan Island, July 18-20, 2012
- Journal submission, Energy and Buildings 2013 (under review)

Next Steps and Future Plans

Next Steps and Future Plans:

- Monitored evaluation of energy performance, occupant impacts, and economics of advanced window and daylighting systems in demonstration commercial buildings in hot/cold and hot regions of China
- Improved understanding of occupant response to advanced technologies and impacts on actual building performance in China and the US
- Improvements to advanced technologies based lessons learned in real world building demonstrations

REFERENCE SLIDES

Project Budget

Project Budget: 2010-2014: \$645K total, 2014: \$340K

Variances: Carryover from 2013 due to production delays by Sage Electrochromics; controls R&D at LBNL and M&V of Shanghai demonstration delayed to 2014.

Cost to Date: 2010-2014: \$307K, 2014: \$28K

Additional Funding: \$200K in-kind contribution from Saint-Gobain, Sage Electrochromics, Dow Chemical, Lutron Electronics, and 3M (materials, technical support).

Budget History

1/1/2010– FY2010-2013 (past)		FY2014 (current)		FY2015 – 12/31/15 (planned)	
DOE	Cost-share	DOE	Cost-share	DOE	Cost-share
\$305K	\$50K	\$340K	\$150K	\$200K	\$100K

Project Plan and Schedule

Project Schedule												
Project Start: January 2010	Completed Work											
Projected End: December 2015	Active Task (in progress work)											
	◆ Milestone/Deliverable (Originally Planned)											
	◆ Milestone/Deliverable (Actual)											
	FY2013				FY2014				FY2015			
Task	Q1 (Oct-Dec)	Q2 (Jan-Mar)	Q3 (Apr-Jun)	Q4 (Jul-Sep)	Q1 (Oct-Dec)	Q2 (Jan-Mar)	Q3 (Apr-Jun)	Q4 (Jul-Sep)	Q1 (Oct-Dec)	Q2 (Jan-Mar)	Q3 (Apr-Jun)	Q4 (Jul-Sep)
Past Work												
Q2 Milestone: Initiate Sage and Lutron field tests						◆						
Q3 Milestone: Initiate integrated controls test							◆					
Q3 Milestone: Initiate SGRS demonstration								◆				
Q4 Milestone: Initiate Xingye demonstration									◆			
Current/Future Work												
Q1 Milestone: complete field tests										◆		
Q2 Milestone: complete SGRS demonstration											◆	
Insert more Milestones as needed												



A Project of CERC-BEE (US-China Clean Energy Research Center Building Energy Efficiency Consortium)

Pioneering U.S. – China Innovation for Widespread Adoption of Very Low Energy Buildings Through Partnerships and Real World Impact



U.S. Research Leads



U.S. Industrial Partners (Funding +40% Annual Average Growth Rate)

Research Strategy → Huge Impact:

- U.S./China construction market ~ 2B m2
- CO2 savings ~ 100Mt/year by 2025

ABOUT: CERC-BEE is a five year, \$50M program created by the U.S. Department of Energy and Chinese Ministry of Science and Technology.

R&D TEAMS: U.S. national laboratories, and U.S. and Chinese universities, and research institutes team up with industry partners to accelerate innovation and deployment.

SELECTED RESEARCH OUTCOMES:

- Launched eight new products and developed two software tools (e.g. Cloud tool for microgrids, 40 new users from China)
- Won R&D Top 100 Award for GSHP by Climate Master
- Exceeded IP goals: ~ 25 patents filed, 4 approved; inventions disclosed and more in process (e.g. sprayable liquid flashing, cool roof materials)
- Developed 20 standards (e.g. LBNL involved in new Chinese commercial building code revision)
- Published 135 Chinese and 54+ US academic research papers

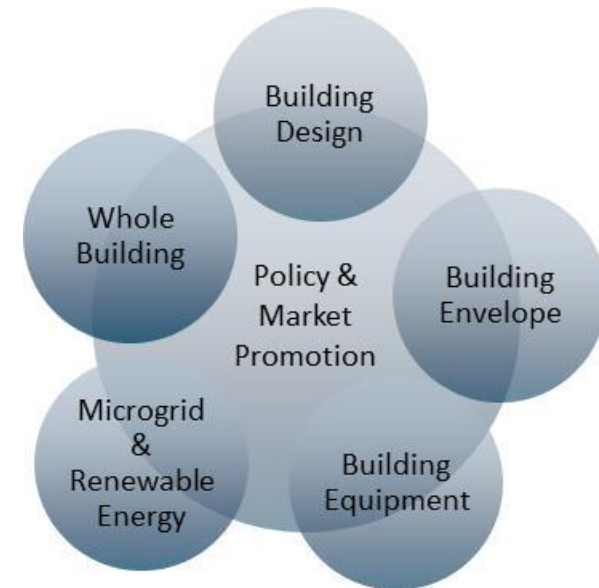
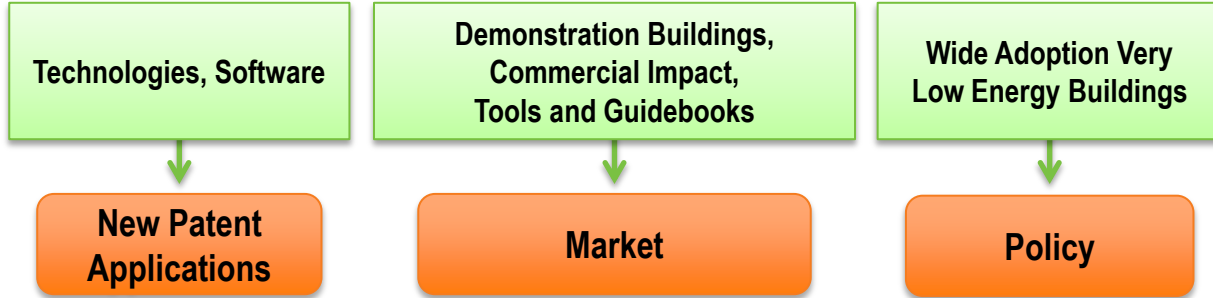

Website: cercbee.lbl.gov