



BUILDING AMERICA TOP INNOVATIONS 2013 PROFILE

INNOVATIONS CATEGORY:

3. Effective Guidance and Tools
- 3.1 High-Performance Home Solutions

TOP INNOVATOR:

BSC

Window Replacement, Rehabilitation, & Repair Guide

Building Science Corporation estimates whole-house energy savings of up to 10% can be achieved in over 5 million homes annually by improving the energy efficiency of existing homes with these window repair and rehabilitation steps.

Old single-glazed windows have such low thermal resistance that their effect on the overall thermal resistance of the walls can be staggering. Building America recommends several ways to improve the performance of existing windows at varying price points.

Owners of older homes who want to improve their homes' efficiency often conclude that window replacement is a necessary first step. They are right that windows can be a significant source of air leakage and heat loss (windows account for 18% of wall area in most homes); however, total replacement is only one of many options that can improve the windows' energy efficiency, as shown in a series of guides for homeowners and contractors prepared by the Building Science Corporation for the U.S. Department of Energy's Building America Solution Center, an online resource of home construction how-to's.

The guides by Building Science Corporation start with a decision tree that helps designers, contractors, and homeowners navigate the often difficult decision-making process involved in trying to determine what course of action is best to take regarding window upgrades in existing homes.

The decision tree warns of things to look for first including signs of lead paint or water intrusion, which are situations that must be dealt with as part of the remediation. Workplace hazards are also discussed.

Water infiltration is dealt with at considerable length because windows are one of the likeliest components in the building structure for water entry and because water intrusion and resultant damage may have gone on unnoticed for some time as water can enter the wall cavity through and around the window assembly. Suggestions for investigating sources of water intrusion are provided.

The condition of the decorative trim around the window can be an indication of water damage but deterioration of the trim is typically an aesthetic problem not a performance problem. However, if the window sill is damaged, it should be replaced because it is the means by which water will drain out away from the house or, incorrectly, into the wall. Damaged or deteriorating window sashes, frames, or casings (not the decorative trim but the actual window framing) may be an indication the window itself needs replacing, depending on the extent of the damage.

(Top left) Low-E storm windows are one option for improving the thermal performance of existing windows.



**BUILDING AMERICA
TOP INNOVATIONS**

Recognizing Top Innovations in Building Science – The U.S. Department of Energy's Building America program was started in 1995 to provide research and development to the residential new construction and remodeling industry. As a national center for world-class research, Building America funds integrated research in market-ready technology solutions through collaborative partnerships between building and remodeling industry leaders, nationally recognized building scientists, and the national laboratories. Building America Top Innovation Awards recognize those projects that have had a profound or transforming impact on the new and retrofit housing industries on the road to high-performance homes.

Building Science Corporation recommends several possible options for improving window performance:

- **Rehabbing the window** – remove the window and sash; clean, paint, and caulk the frames; install new gaskets around the sashes; repair or replace pulleys, cords, and weights.
- **Modifying the window sash** – remove single-pane glass from the sash and replace with double-pane glass; typically done by a window restoration specialist.
- **Replacing the window sash** – replace the window panes and sashes and replace sash weights with new jamb liners, paint jambs with waterproof membrane or elastomeric paint.
- **Inserting a replacement window** – remove existing sash and panes; remove pulleys; seal frames and coat with waterproof membrane; treat as a rough opening for the new window and frame.
- **Conducting a complete window replacement** – remove existing window and frame; add any blocking needed to adjust size of rough opening; line all sides with liquid or self-adhered waterproof membrane that extends 4 inches out on exterior wall.

If the windows are in fairly good working order with no rotting wood or broken parts and no water intrusion issues and the only concerns are heat loss and air leakage, another option to consider is storm windows. Interior storm windows come in two varieties—temporary and permanent. Temporary storm windows are installed seasonally in the winter and removed during the summer. Permanent storm windows are installed permanently and stay in place to provide an air sealing and insulating benefit year round. They typically have panels that can slide open and closed. Condensation potential can be minimized by ensuring that the interface between the interior storm and the window frame is as air tight as possible, that potential air paths like pulleys for sash weights are sealed, and if necessary that a slight amount of ventilation be provided to the outside by shimming open the outside window. Exterior storm windows are also available in permanent and seasonally installed varieties. To minimize condensation potential, the inside window should be made as airtight as possible and the storm window should have weep holes to add the slight ventilation needed to mitigate condensation. Storm windows with low-emissivity coatings are available and should be selected wherever possible to reap the additional benefits of low-e glass coatings, which include reduced heat loss in the winter and lower heat gain in the summer.

- New triple-glazed window, existing window and frame to be removed
- New sealant
- New backer rod and sealant
- New plastic shims at window 1/4 points (2 locations per window)
- New sealant to minimize water penetration at sill
- New beveled siding (to create sloped sill pan flashing)
- New sill extension and trim below
- New liquid-applied or sheet membrane pan flashing turned up a minimum 2" at jambs and shingle lapped down over new weather-resistant barrier
- New or reinstalled existing interior window trim
- New weather-resistant barrier
- New siding
- Existing sheathing and stud wall

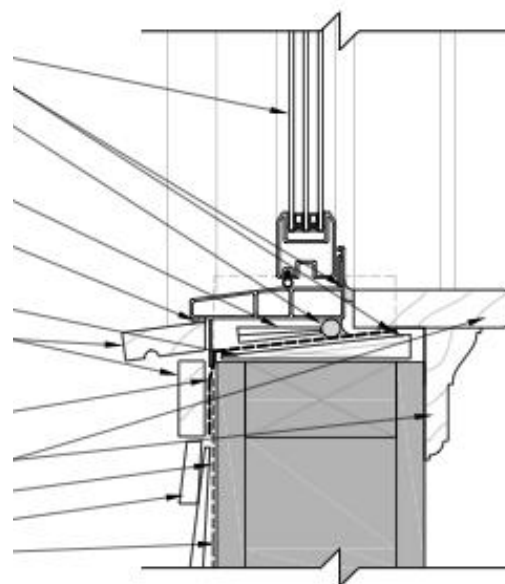

This sill detail shows window replacement in conjunction with siding replacement.

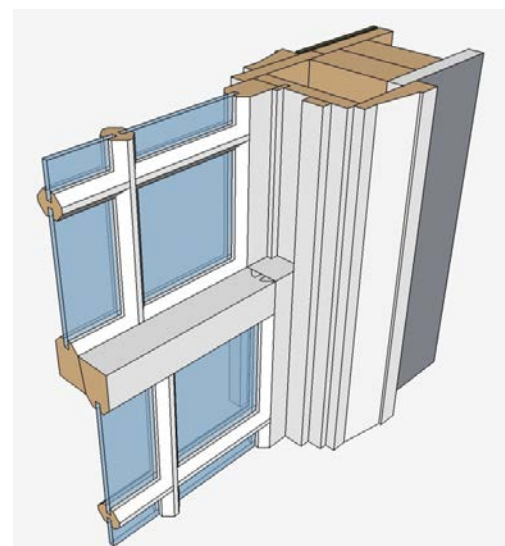

Air sealing of the jambs and framing is an important part of window rehabilitation.

REFERENCES

Baker, P. 2012. *Measure Guideline—Wood Window Repair, Rehabilitation, and Replacement*, RR-1203, Building Science Corporation, http://apps1.eere.energy.gov/buildings/publications/pdfs/building_america/measure_guide_wood_windows.pdf