

3RD
ANNUAL

ENERGY STORAGE
GRAND CHALLENGE SUMMIT

Rapid Operational Validation Initiative (ROVI) Overview



ENERGY STORAGE
GRAND CHALLENGE
U.S. DEPARTMENT OF ENERGY



Vinod Siberry

Technology Manager, Office
of Electricity, U.S.
Department of Energy



Vincent Sprengle

Senior Advisor, Pacific
Northwest National
Laboratory

3RD
ANNUAL

ENERGY STORAGE
GRAND CHALLENGE SUMMIT

Background and Strategic Overview: ROVI



ENERGY STORAGE
GRAND CHALLENGE
U.S. DEPARTMENT OF ENERGY

Research Development and Demonstration (RD&D) for LDES Needed To Achieve New Energy Future

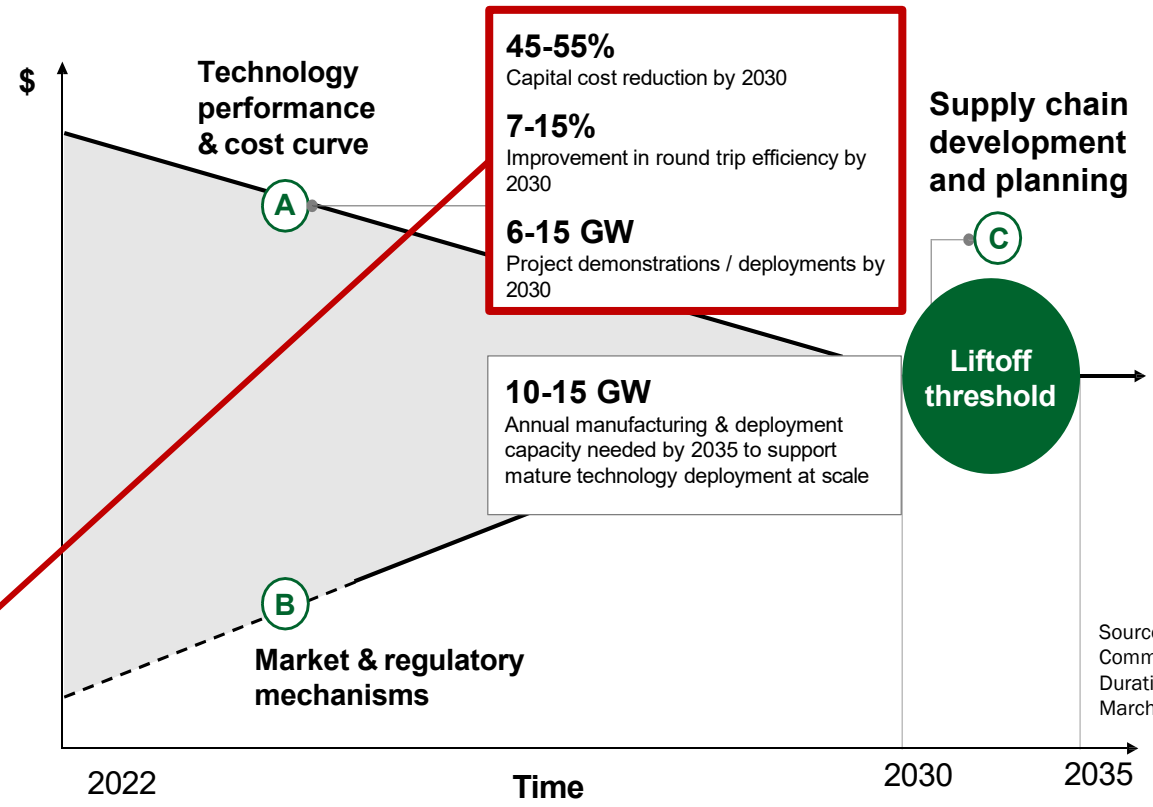
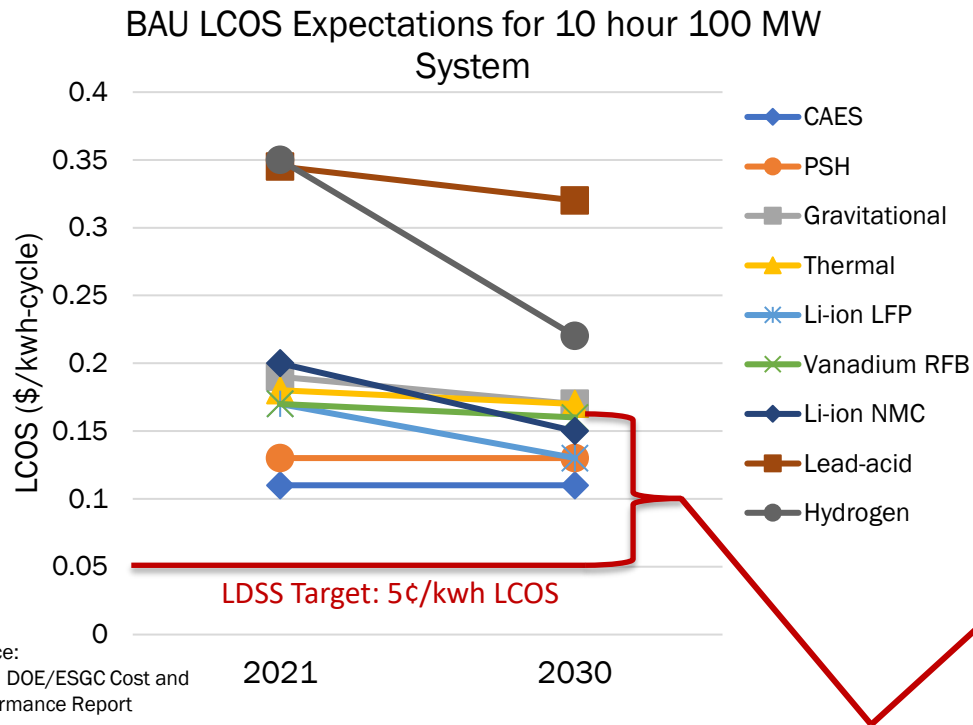

DOE initiatives are closing these RD&D gaps but what else is needed before we can reach widespread deployment targets?

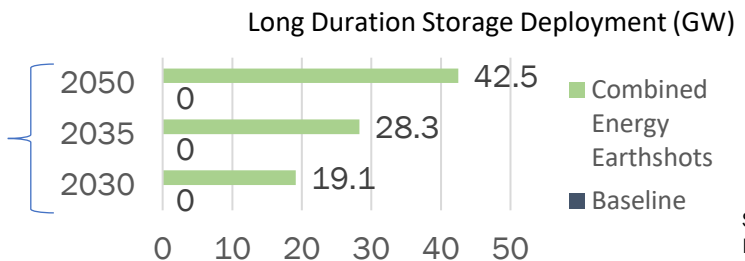

Source: Thirdway/Evolved Energy Research

Promising LDES Technologies must not only close RD&D gaps but validate this to industry...and soon!

<8 years to validate lifetime cost and performance for an emerging LDES technology can begin commercial deployment process in time for operation by 2035

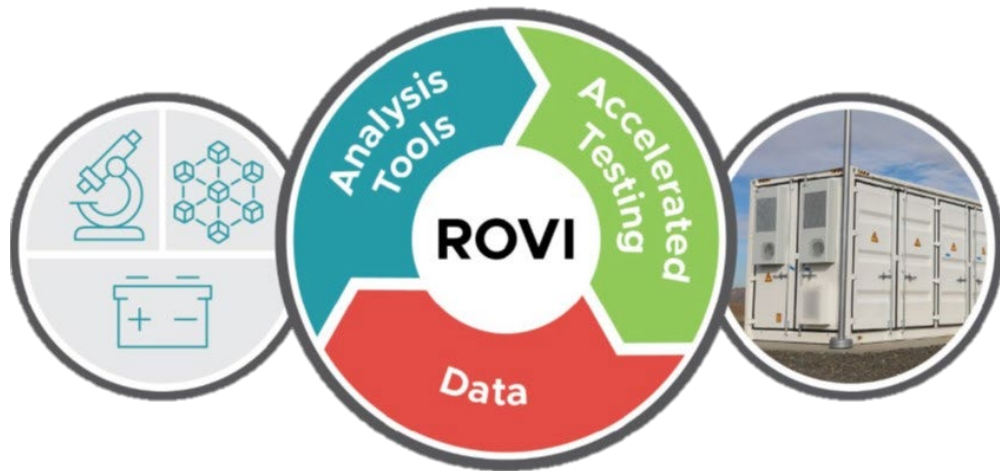
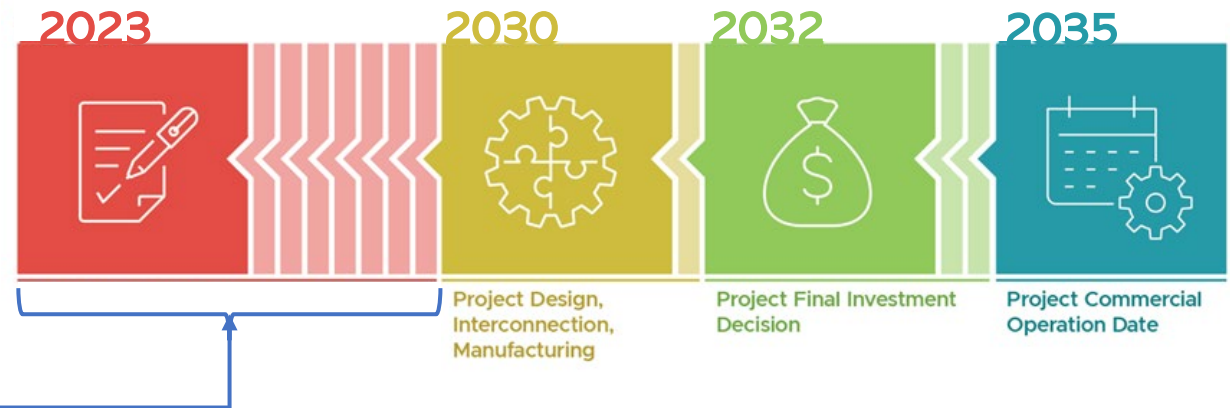

End Goal:
Bankable storage technologies
 ≥ 15 financial grade performance projections with ≤ 1 year of real time testing required

Strategy and Implementation Step 1: Data Collection



Rapid Operational Validation Initiative (ROVI)

Office of Electricity

Office of Electricity » Rapid Operational Validation Initiative (ROVI)

About ROVI

There are many innovative energy storage technologies being developed today that are promising candidates to achieve important cost and performance targets, such as DOE's Long Duration Storage Shot, and ultimately reach widespread commercial deployment needed to facilitate a reliable, clean, and affordable electricity system of the future. The focus of Office of Electricity's Rapid Operational Validation Initiative (ROVI) is to greatly reduce time required for emerging energy storage technologies to go from lab to market by developing new tools that will accelerate the testing and validation process needed to ensure commercial success. To develop these tools, ROVI will employ innovative data science methods such as artificial intelligence and machine learning that will leverage large sets of energy storage performance data at different scales to facilitate generating lifetime performance predictions for new technologies with minimal real-time testing required.

Data Contribution

Accomplishing ROVI will require a wide range of data inputs (e.g., cell level tests, module testing and complete systems) and integration of that data into a standardized format that is consistent across technology types and scales (e.g., laboratory, field, and synthetic data). On this webpage you can find the files



Data Collection Requirements

Download ROVI Data Requirements and Template Files Here:

- placeholder
- placeholder

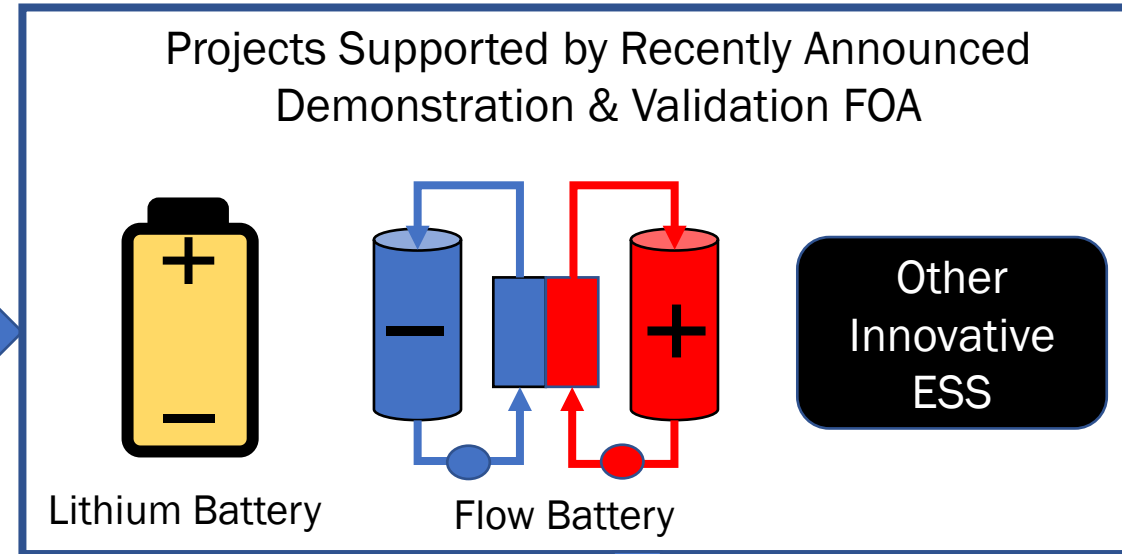

System Level Data

OE RD&D Investments



Materials, Stack/Module Level Data



ROVI Data Hub

[Rapid Operational Validation Initiative \(ROVI\) | Department of Energy \(doe.gov\)](#)

3RD
ANNUAL

ENERGY STORAGE
GRAND CHALLENGE SUMMIT

ROVI

Accelerating the adoption of energy
storage



ENERGY STORAGE
GRAND CHALLENGE
U.S. DEPARTMENT OF ENERGY

ROVI: Objective

Develop new accelerated testing methodologies, AI/ML based analysis tools & validation methods to predict 15+ years of investment-grade performance with < 1-year of data

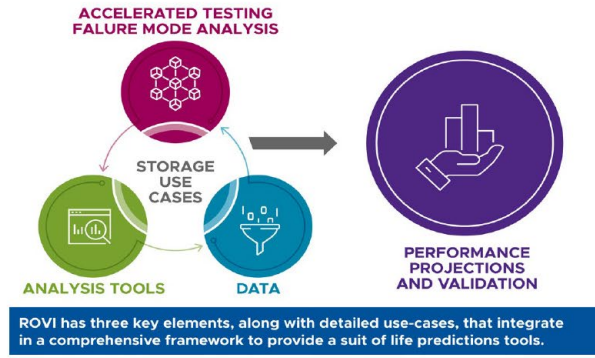

Data

- Develop sufficiently large set of performance and synthetic data across scales for AI/ML tools. Create secure, IP protected Datahubs that can handle wide range of varied data streams.

Analysis Tools

- Create a comprehensive suite of AI/ML tools that facilitate life predictions of key energy storage technologies in critical-use scenarios with minimal real-time testing. Tools must function across various scales and technologies

Accelerated Testing:

- Understand technology failure modes and develop accelerated testing methods.

Use-Cases

- Define critical use-cases that inform storage operating parameters.

ROVI: - Linking Data, Tools, and Analysis across Scales

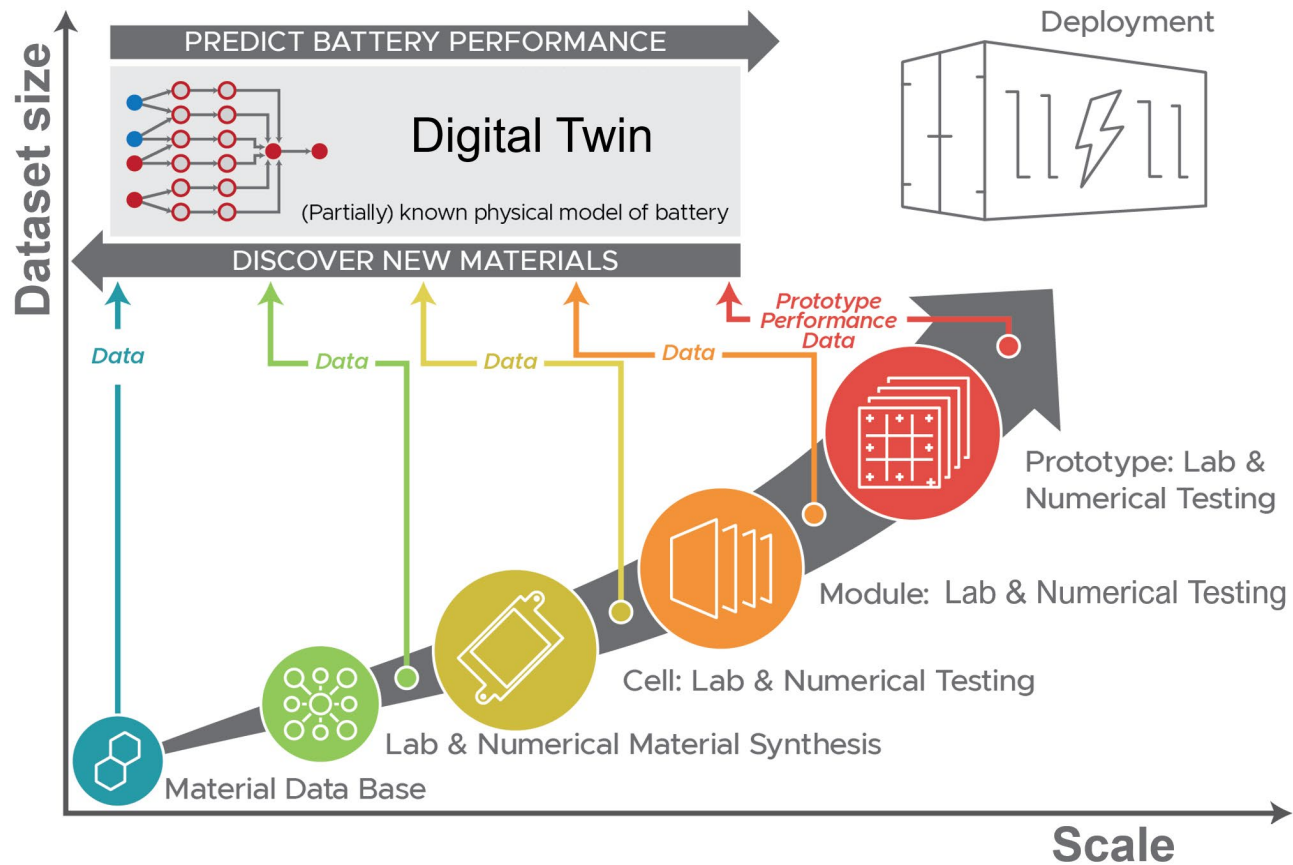

ROVI currently focused on:

Li-ion

- Large data sets at materials, cells, modules, and deployed systems.
- Understanding of failure modes, accelerated testing, AI/ML tools to train models.

Flow Batteries

- Initial AI/ML tools developed, materials to stack
- Expands current approach and lays groundwork for other technologies.

ROVI: Phases 1-4

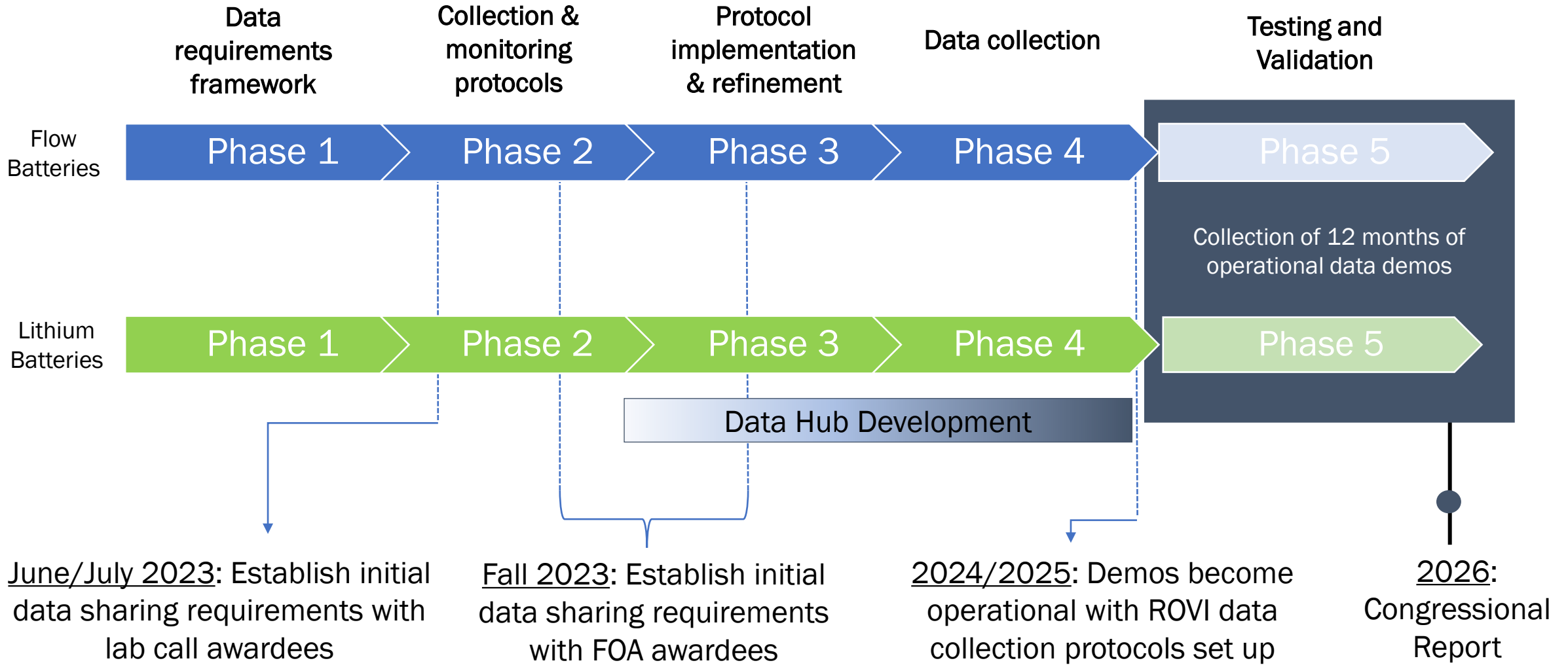

ROVI - Team



Team has extensive experience in:

- *Battery R&D,*
- *lifetime prediction (physics/ML/twin),*
- *data protocols and data hub development,*
- *accelerated testing, and*
- *deployment testing*

ROVI – How to engage

Industry Working Groups

- e.g. BCI/Cleantech Strategies Flow Battery Working Group
- working groups around other technologies, investment community.

Contact ESGC Leadership team:

- Vincent Sprenkle – vincent.sprenkle@pnnl.gov
- Wei Wang - wei.wang@pnnl.gov
- Sue Babinec - sbabinec@anl.gov
- Eric Dufek - eric.dufek@inl.gov
- Kandler Smith - kandler.smith@nrel.gov
- Michael Starke - kandler.smith@nrel.gov
- Valerio De Angelis - vdeange@sandia.gov

Or any of our speakers today

ROVI – Today's Panel

1. Data Requirements Development: Yuliya Preger - Sandia
2. Data Infrastructure: Srikanth Allu - ORNL
3. AI/ML Li-ion: Noah Paulson - ANL
4. AI/ML Flow: Jie Bao - PNNL
5. Accelerated Testing: Kevin Gering - INL



Srikanth Allu

Computational
Research Scientist,
Oak Ridge National
Laboratory



Jie Bao

Research Engineer,
Pacific Northwest
National Laboratory



Kevin Gering

Research Engineer,
Idaho National
Laboratory



Noah Paulson

Assistant
Computational
Scientist, Argonne
National Laboratory



Yuliya Preger

Chemical Engineer,
Battery Reliability,
Sandia National
Laboratories

3RD
ANNUAL

ENERGY STORAGE
GRAND CHALLENGE SUMMIT

ROVI Data Requirements

Yuliya Preger, Sandia National Labs



ENERGY STORAGE
GRAND CHALLENGE
U.S. DEPARTMENT OF ENERGY

Energy Storage Industry has Recognized a Need for Data Collection Standards

- **IEEE 2800-2022 – Transmission Interconnection – Inverter Based**
 - Specific requirements for data recording intervals, equipment monitored, control settings, fault recording
- **IEEE 1547.9 – Guide for Using IEEE Std 1547 for Interconnection of Energy Storage**
 - Recommendations for SOC/SOH reporting, interoperability/information sharing
- **NERC 1600 GADS**
 - Effective Jan. 1, 2024: reporting of configuration parameters and basic performance for storage used in hybrid PV and wind systems
- **Electric Power Research Institute Energy Storage Data Submission Guidelines**
 - Detailed descriptions of data points and architectures for data collection

Overview of ROVI Data Guidance

DE-FOA-0002867: Bipartisan Infrastructure Law Long-Duration Energy Storage Demonstrations

“In order to fulfill statutory objectives for reporting and testing and validation requirements outlined in the BIL and Energy Act of 2020, OCED will leverage ROVI to collect quality data from deployments funded by the BIL provisions.”

ROVI requirements leverage:

- (1) existing guidance (e.g., IEEE, EPRI, NERC)
- (2) labs’ experience with Li-ion and flow demonstration projects
- (3) perspectives of representative stakeholders (utility, developer, manufacturer)

ROVI provides guidance for three kinds of information:

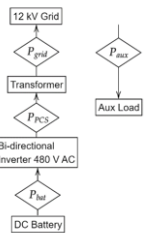

Metadata

Year/Date	VI	Acquisition Method	Acquisition Rate	Number of Samples	Resolution (V)	Resolution (A)	Resolution (W)	Resolution (kWh)
2017-07-20 00:00	NA	0014	NA	NA	NA	NA	NA	NA
2017-07-20 01:00	NA	0014	NA	NA	NA	NA	NA	NA
2017-07-20 02:00	NA	0014	NA	NA	NA	NA	NA	NA
2017-07-20 03:00	NA	0014	NA	NA	NA	NA	NA	NA
2017-07-20 04:00	NA	0014	NA	NA	NA	NA	NA	NA
2017-07-20 05:00	NA	0014	NA	NA	NA	NA	NA	NA
2017-07-20 06:00	NA	0014	NA	NA	NA	NA	NA	NA
2017-07-20 07:00	NA	0014	NA	NA	NA	NA	NA	NA
2017-07-20 08:00	NA	0014	NA	NA	NA	NA	NA	NA
2017-07-20 09:00	NA	0014	NA	NA	NA	NA	NA	NA
2017-07-20 10:00	NA	0014	NA	NA	NA	NA	NA	NA
2017-07-20 11:00	NA	0014	NA	NA	NA	NA	NA	NA
2017-07-20 12:00	NA	0014	NA	NA	NA	NA	NA	NA
2017-07-20 13:00	NA	0014	NA	NA	NA	NA	NA	NA
2017-07-20 14:00	NA	0014	NA	NA	NA	NA	NA	NA
2017-07-20 15:00	NA	0014	NA	NA	NA	NA	NA	NA
2017-07-20 16:00	NA	0014	NA	NA	NA	NA	NA	NA
2017-07-20 17:00	NA	0014	NA	NA	NA	NA	NA	NA
2017-07-20 18:00	NA	0014	NA	NA	NA	NA	NA	NA
2017-07-20 19:00	NA	0014	NA	NA	NA	NA	NA	NA
2017-07-20 20:00	NA	0014	NA	NA	NA	NA	NA	NA
2017-07-20 21:00	NA	0014	NA	NA	NA	NA	NA	NA
2017-07-20 22:00	NA	0014	NA	NA	NA	NA	NA	NA
2017-07-20 23:00	NA	0014	NA	NA	NA	NA	NA	NA

Streaming data

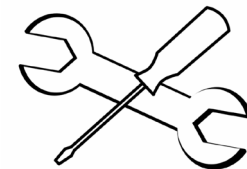

Maintenance data

System Metadata

Metadata is essential for describing and organizing data streams from different deployment projects. The ROVI-requested metadata includes: (1) general system specs, (2) system physical layout, (3) meter layout, and (4) vendor data sheets.

Li-ion system metadata excerpt

Metadata	Unit	Value	Description
General System Specifications			
Rated power	kVA		
Rated energy	kWh		Provide power at which Rated Energy is measured.
Min operating temperature	°C		
Max operating temperature	°C		
Preferred operating temperature window (lower to upper bound)	°C		
Max SOC (operating limit)	%		
Min SOC (operating limit)	%		

Example power meter layout

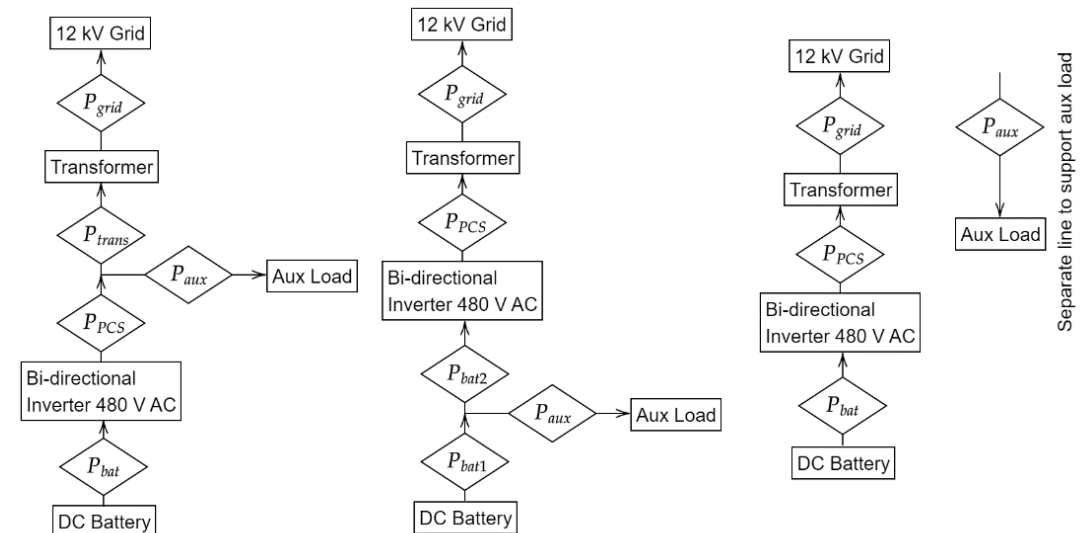

System Streaming Data

ROVI provides guidance for streaming data collection during normal operation. This guidance may be adjusted based on the properties of the battery management system, bandwidth for data streaming, etc.

Li-ion system streaming data excerpt

Data Point	Units	Sample Rate Minimum (sample/s)	Values	Notes
System Level				
Time		1	value	ISO 8601 format
Power at Point of Connection with Grid	kW	1	value	see meter layout diagram
Reactive Power at Point of Connection with Grid	kVAR	1	value	see meter layout diagram
Power Factor at Point of Connection with Grid		1	value	see meter layout diagram
AC RMS Voltage (A/B/C)	VRMS	1	value	distinct output for A/B/C
AC RMS Current (A/B/C)	IRMS	1	value	distinct output for A/B/C
SOC		1	value	0.01% precision

System Maintenance Data

Streaming data does not provide adequate context for the events (planned and unplanned) that impact performance. ROVI is providing a log for project performers to update whenever an event causes something to be taken offline, replaced, or updated.

Event #	Event Information			Component Information		Event Description		Resolution						
	Planned vs Unplanned	% System Rated Power Unavailable	Event Category (see options)	Component (see options)	Additional Component Details? (e.g., associated streaming label in system diagram)	Event Start Time (ISO 8601 format)	Short Event Description	Root Cause	Solution	Event Resolution Time (ISO 8601 format)	Event Duration (days, hours, minutes)	Related to Previous Event #	Enter outage duration if less than event duration	Additional Details (provide version ID# if standard firmware update)
1	Unplanned		Hardware	Battery	Container 2, Rack 12	2/2/2020 0:00				3/13/2020 11:01	40 days, 11 hours, 1 minutes	none	3 days	
2	Unplanned		Firmware / Software	Database issue		7/17/2020 0:00	Database software crash	Firmware issue / update firmware with vendor's help.		7/20/2020 0:01	3 days, 0 hours, 1 minutes	1		
3	Planned		Firmware / Software	Update										BMS upgraded to Version 11.2
4	Planned		Hardware	Battery			Replace bad module							

ROVI Data Framework: Next Steps

- ROVI data collection expectations (metadata, streaming data, and maintenance data) for Li-ion and flow systems delivered to DOE
- DOE will finalize data collection requirements with LDES FOA awardees during contracting phase
- ROVI team will implement infrastructure to collect data from demonstration projects (details in next presentation)

3RD
ANNUAL

ENERGY STORAGE
GRAND CHALLENGE SUMMIT

Data Infrastructure



ENERGY STORAGE
GRAND CHALLENGE
U.S. DEPARTMENT OF ENERGY

ROVI Data Architecture - Purpose

- Motivation : Harmonize data integration coming from several sources for effective value extraction and investment grade predictions.
- Design and implement Data Architecture that addresses Collection, Storage, Integration, Distribution, Reporting and Monitoring.

Data collection	Real time (or) Batch
Data Extract, Transform and Load (ETL)	Quality and Synchronization
Data Management and Storage	Distributed, Failover DBs
Data Security and Governance	MFAs, Logging, Access controls
Data Reporting and Monitoring	Continuous quality check - BI tools

Conceptual Layered ROVI Architecture

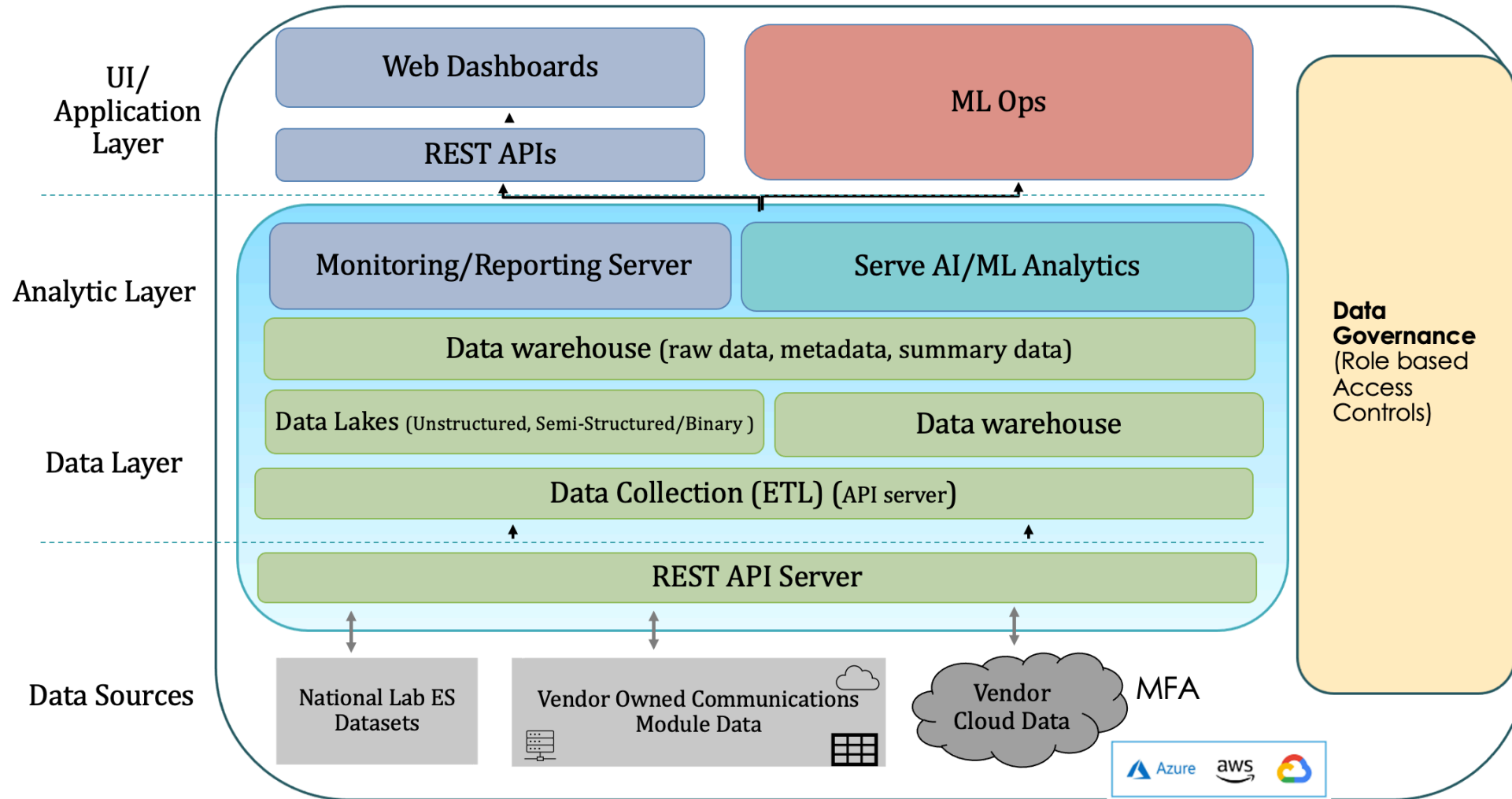

ROVI Data Architecture - Implementation

- ROVI Data Infrastructure : Preliminary evaluation of on-prem/cloud/hybrid infrastructure solutions
- Technologies Selection
 - Data quality and integration : Numerous technologies to enable maximum workflow automation
 - Data Storage (Warehouse/Lakes): Driven by the motivation and collection processes to minimize the risk of data loss
 - Monitoring/Reporting: Continuous and interactive visualizations
- Cyber Security Requirements : Token exchange , MFA to access data, Vulnerability scans, establish the data governance team
- Data Communication : Standardized collection processes and workflows
 - End to end failover solutions from source to storage
- Analytics : Data consistency and completeness for AI-Ready

ROVI Data Architecture - Collection

Connects Vendor Comm. Adapter

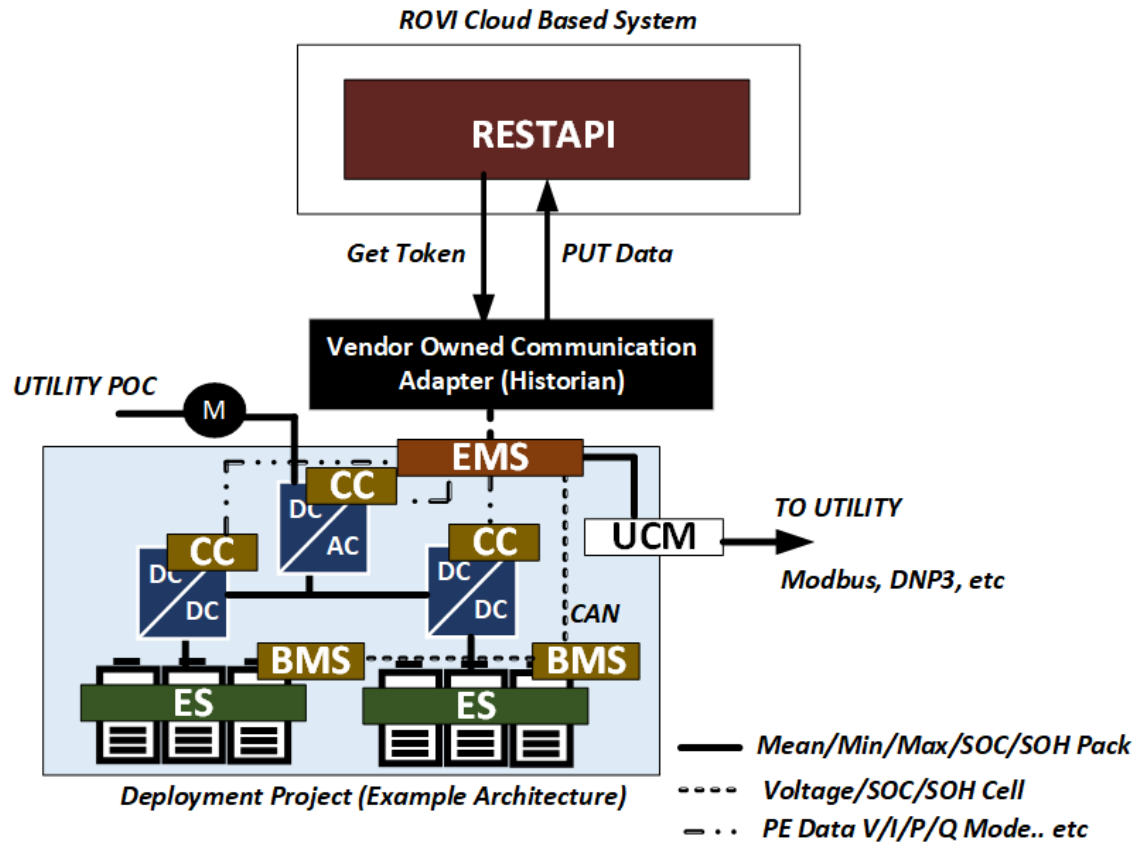

Connects to Vendor Cloud Services

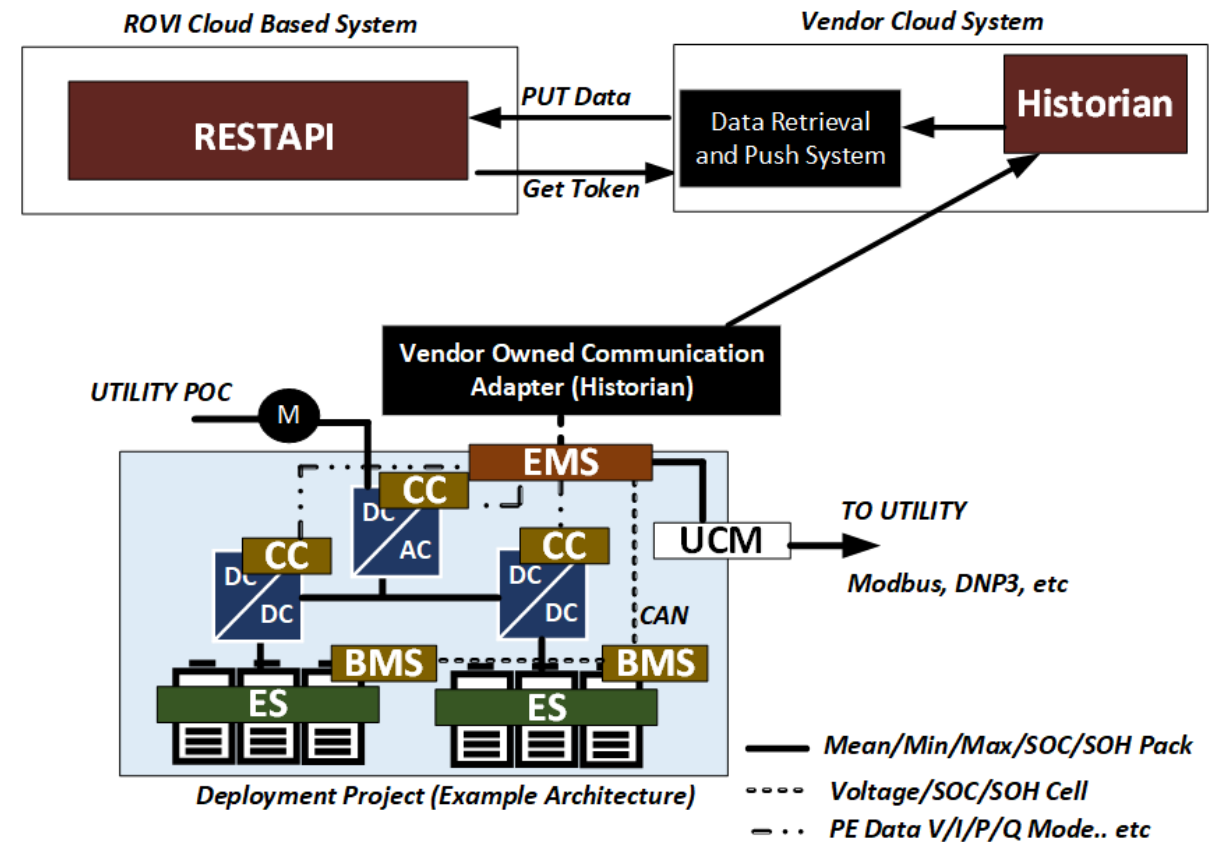

ROVI Data Architecture – DATA Strategy

Vision : harmonize data integration coming from several sources for effective value extraction and investment grade predictions

Capabilities

- ❑ Ingest spatially and temporally disparate raw data using data lakes
- ❑ Data warehouse using standardized data structures and schema for reliable and trustworthy analysis
- ❑ Ability to **host users** to access the data and address broad range of energy issues

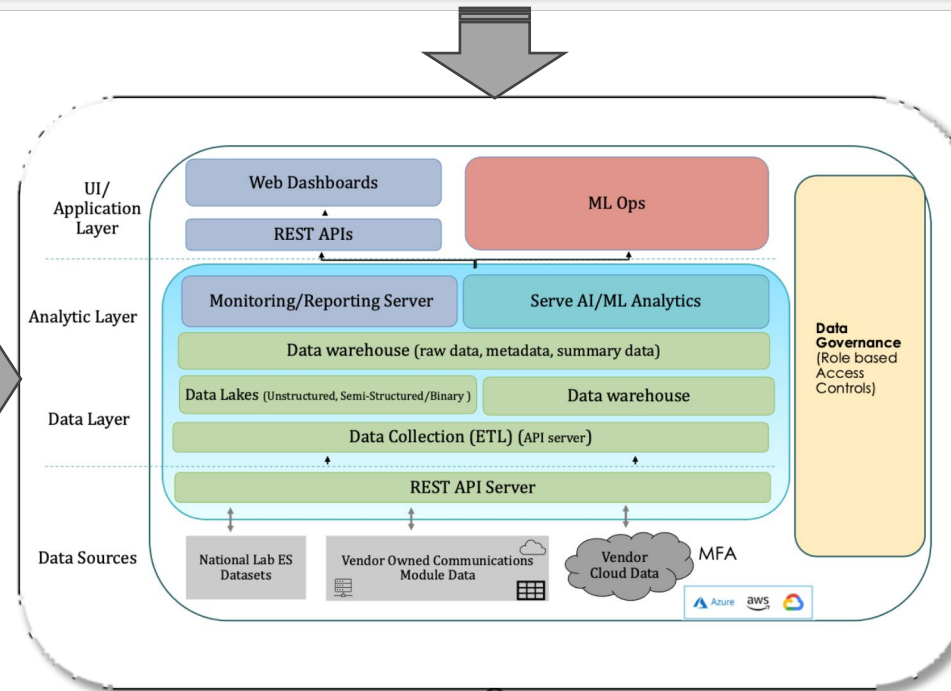

Outcomes

- Host data from several deployments
- Engage broader set of users to access data and address research questions
- Increased community understanding of scaling the deployments

Leveraging resources and expertise

High-Performance Storage System and Scalable Data Center
Expertise from maintaining operational data centers

3RD
ANNUAL

ENERGY STORAGE
GRAND CHALLENGE SUMMIT

AI-DRIVEN DIAGNOSIS AND PROGNOSIS FOR LI-ION BATTERIES



ENERGY STORAGE
GRAND CHALLENGE
U.S. DEPARTMENT OF ENERGY

NOAH PAULSON

Assistant Computational Scientist
Data Science and Learning Division
Argonne National Laboratory

AI LI-ION DIAGNOSIS AND PROGNOSIS

What are the key ROVI predictive capabilities?

Performance metrics (e.g. distributions of capacity, power, round-trip efficiency, OCV, impedances)

Degradation mechanisms, modes and severities

- Degradation mechanism examples: SEI, particle cracking, Li-plating
- Degradation mode examples: Loss of active material (NE, PE), Loss of Li inventory

System response to demands (e.g. installation balance, parasitic losses, cell responses)

Uncertainty and sensitivity for all predictions

AI LI-ION DIAGNOSIS AND PROGNOSIS

How can we deliver these capabilities?

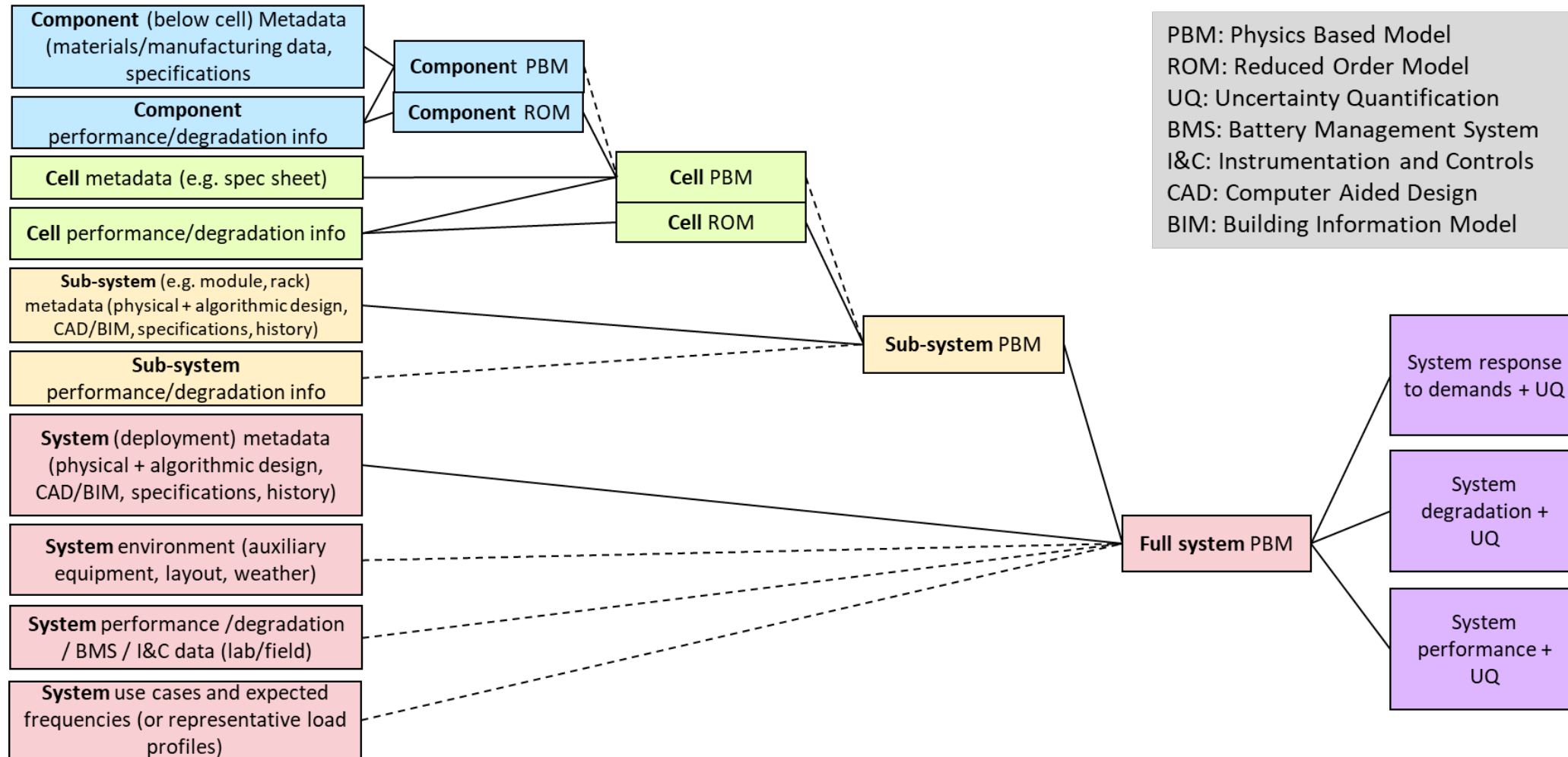

AI LI-ION DIAGNOSIS AND PROGNOSIS

AI/ML predicts battery lifetime and multivariate degradation trends

Predict battery lifetime for Argonne dataset of 300 Li-ion pouch cells representing 6 cathode chemistries

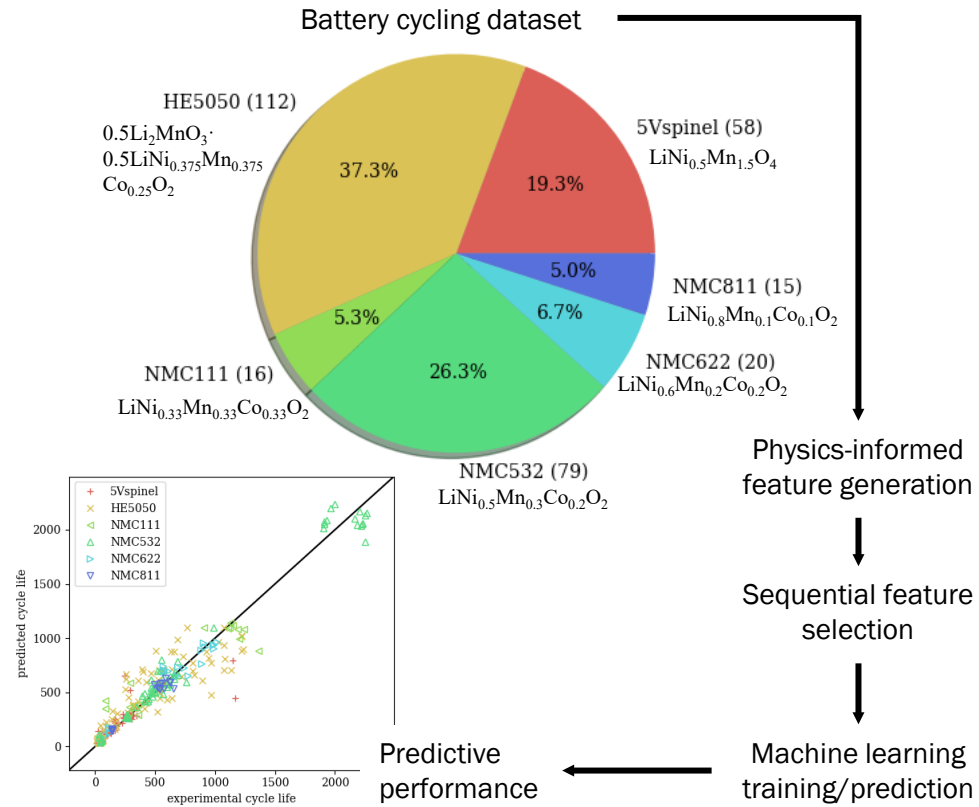

Noah H. Paulson et al 2022 *J. Power Sources* 527 231127

Forecast multivariate advanced state of health (capacity, energy impedances, etc.) via deep learning

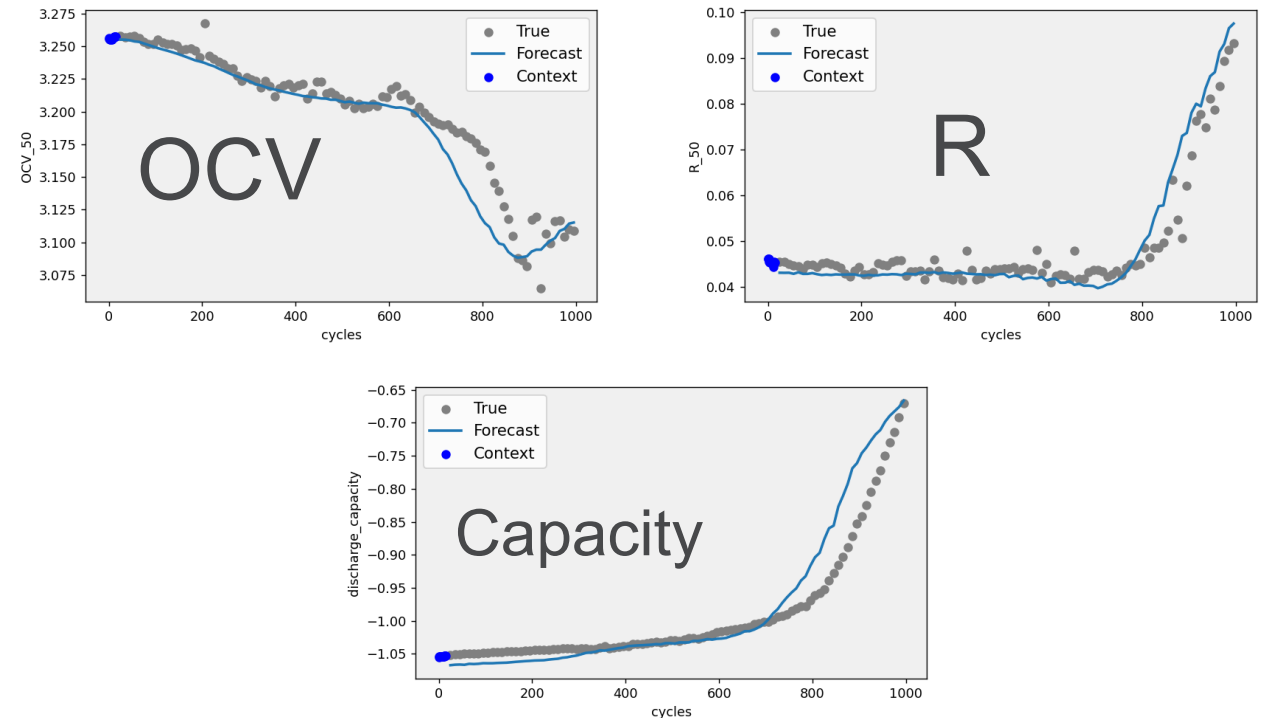

Noah H. Paulson et al in development

AI LI-ION DIAGNOSIS AND PROGNOSIS

ML-assisted battery modeling with quantified uncertainty

Symbolic regression and optimization predicts calendar and cyclic aging, with uncertainty, in LFP-Gr dataset

Calendar aging

Cyclic aging

Refit literature model

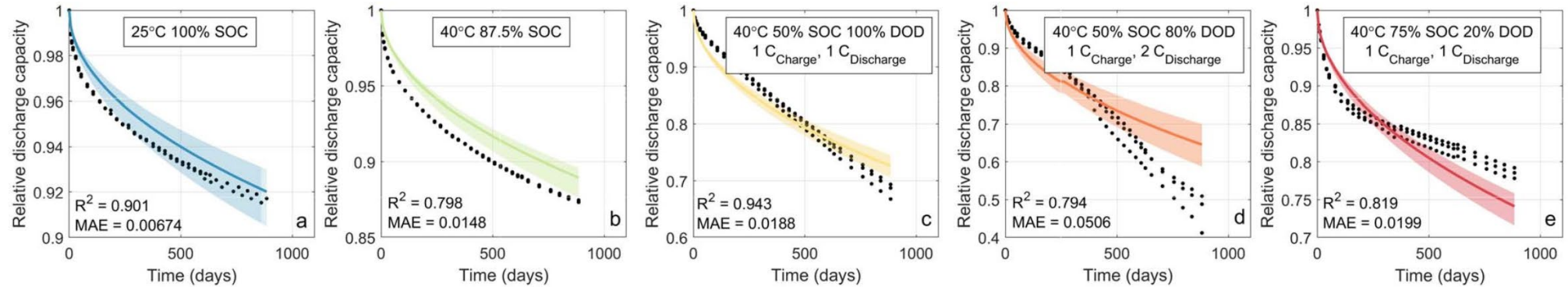

ML assisted

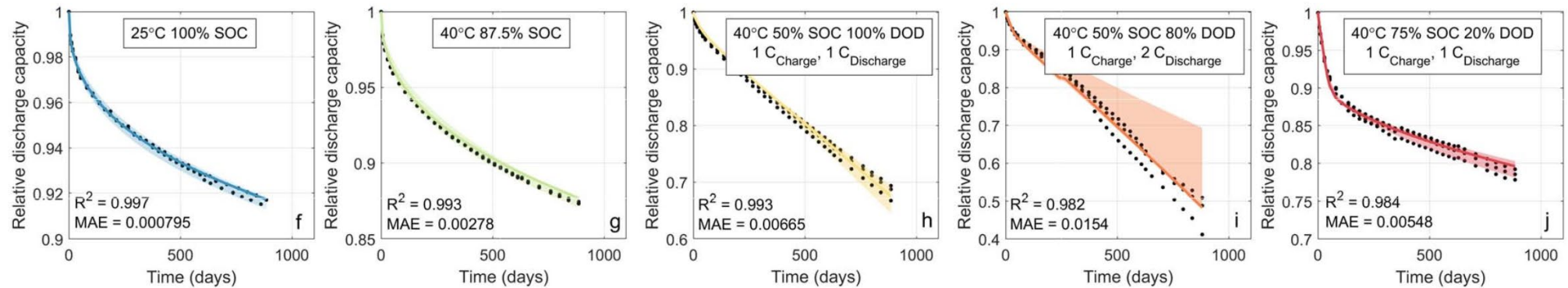

Paul Gasper et al 2022 *J. Electrochem. Soc.* 169 080518

AI LI-ION DIAGNOSIS AND PROGNOSIS

ML for prediction of degradation modes

Cycling info used by ML to classify degradation modes in 44 cells (2 cathode chem, 2 loadings, 5 charge rates)

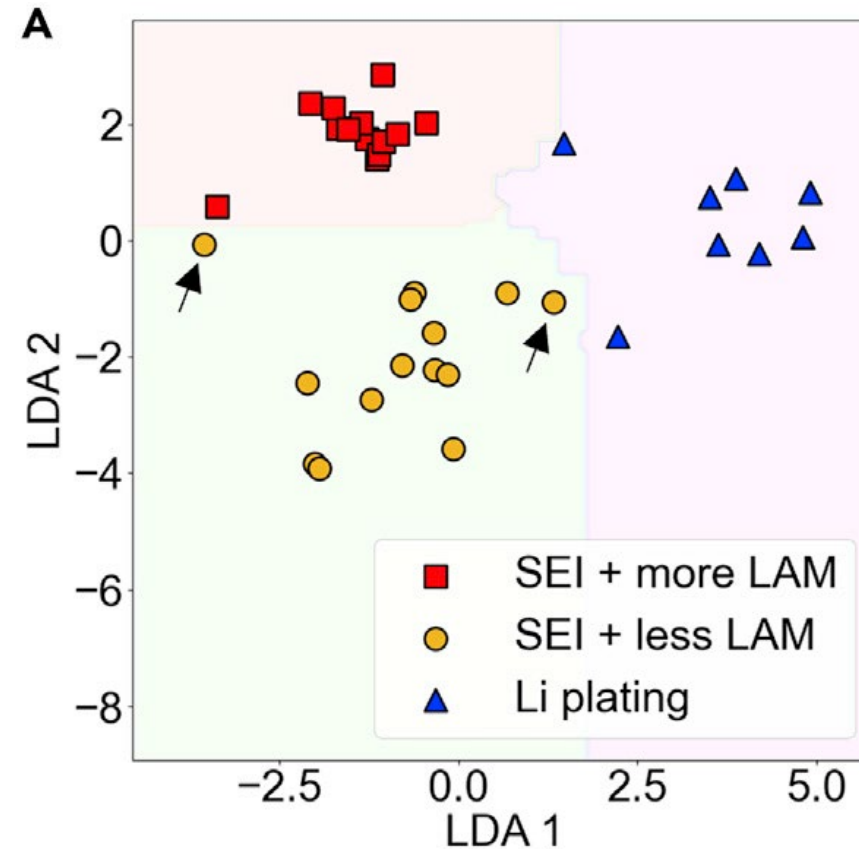
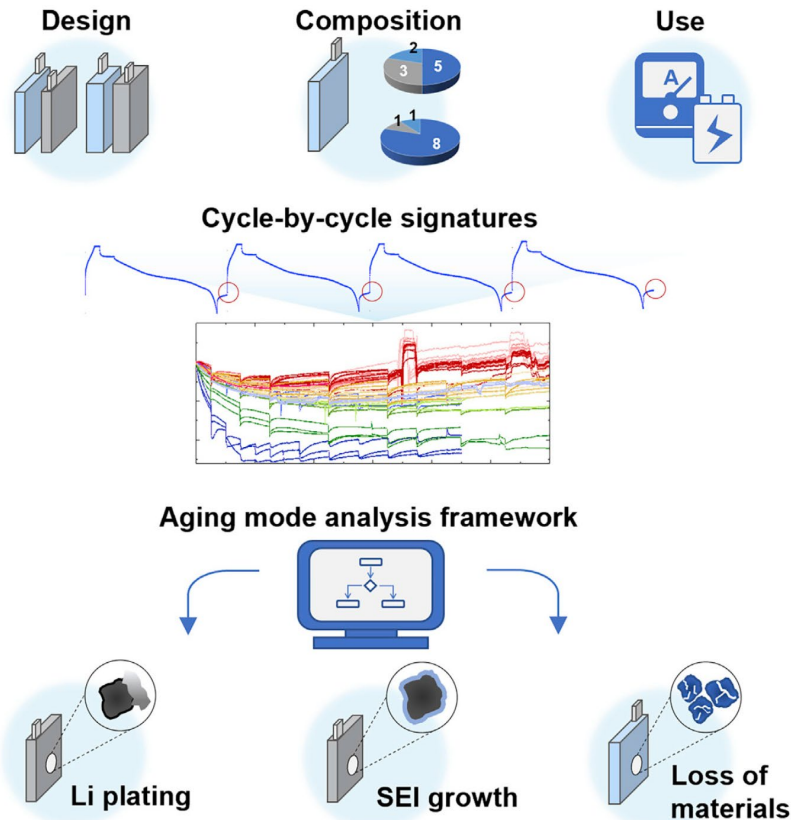

Bor-Rong Chen *et al* 2022 *Joule* 6 2776-2793

3RD
ANNUAL

ENERGY STORAGE
GRAND CHALLENGE SUMMIT

AI/ML Tools and Path Forward for Flow Batteries



ENERGY STORAGE
GRAND CHALLENGE
U.S. DEPARTMENT OF ENERGY

AI/ML Tools and Path Forward for Flow Batteries

Upscaling from Material to System through Physics-Based Models and AI/ML Tools

- Various physics-based models and AI/ML tools have been developed and trained to establish the connections across the scales
- Connecting the cell/stack level AI/ML models into system level model to construct the digital twin of the field deployed RFB LDES system

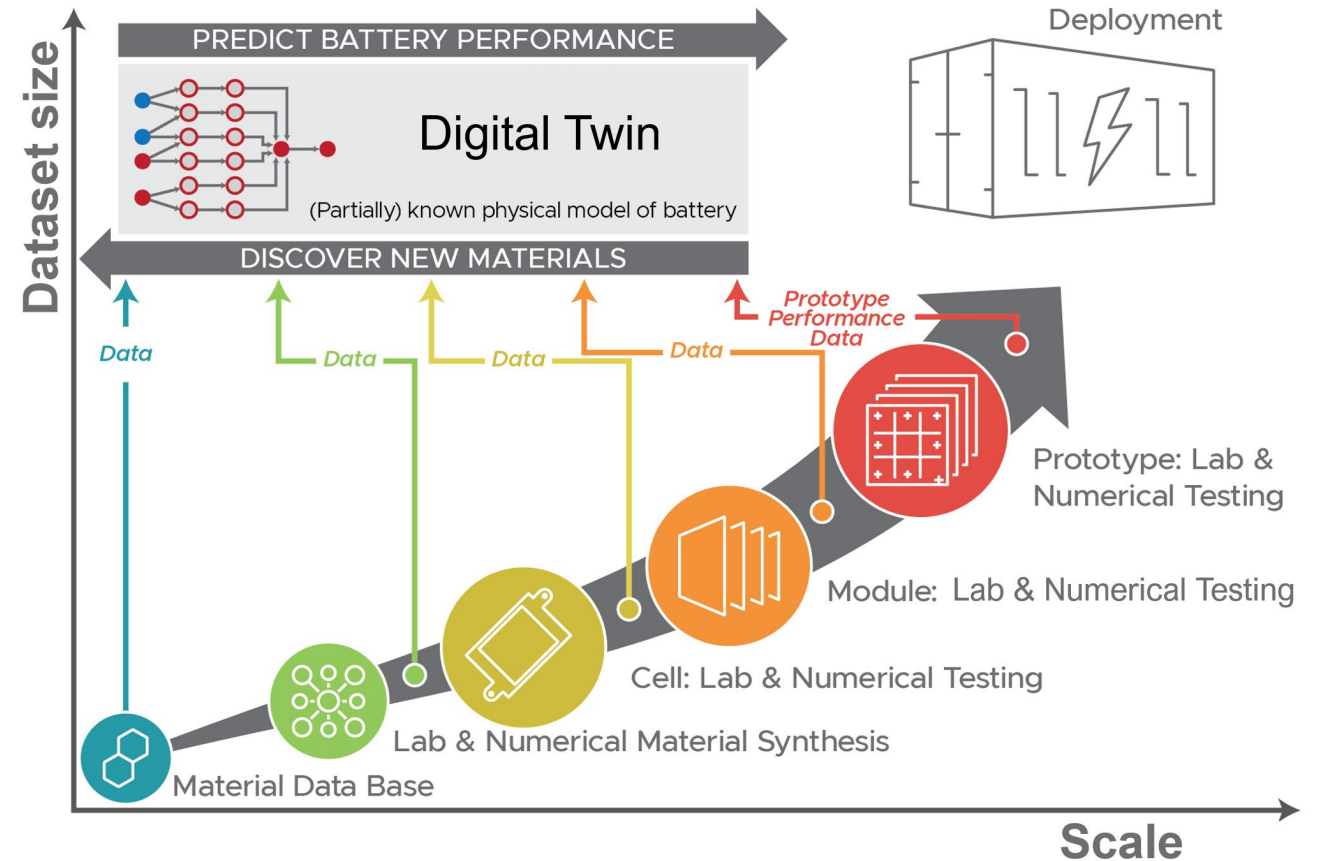



From Molecule Structure to Properties

- DFT calculation for stability and redox potential
- MD calculation for electrolyte viscosity, diffusivity, and conductivity at different concentration and supporting species environments
- Natural Language Processing for collecting data of other properties
- AI/ML models learn the relationship between the molecule structures and properties
- Automation and high throughput experiments for accelerated electrolyte characterizations
- Comprehensive molecular and electrolyte database

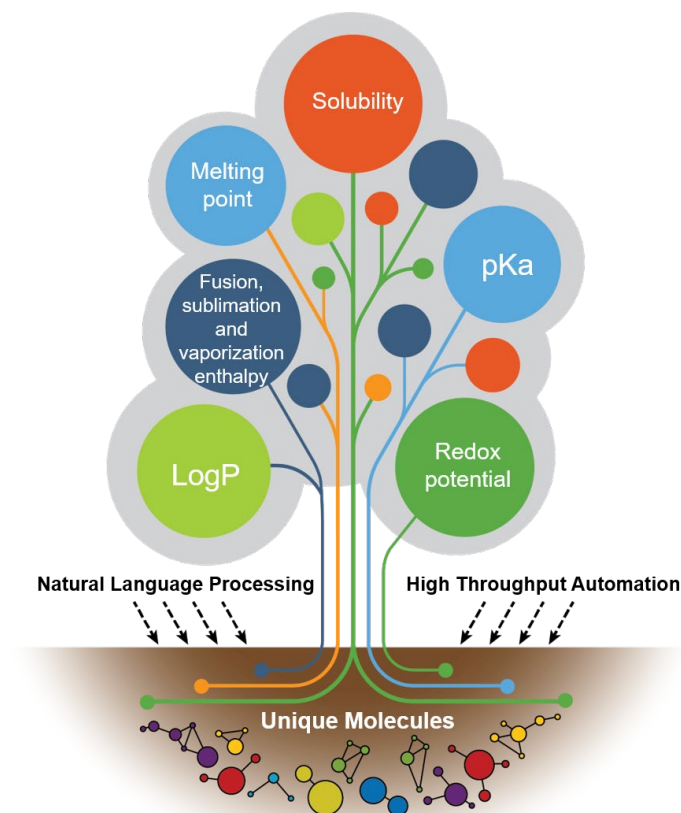

Peiyuan Gao, et al. Scientific Data, 9, 740 (2022)
Peiyuan Gao, et al. Physical Chemistry Chemical Physics, 23, 43, (2021)

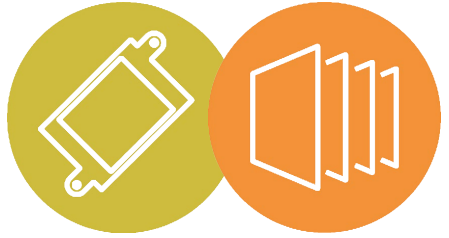

From Properties to Large Cell/Stack Performances

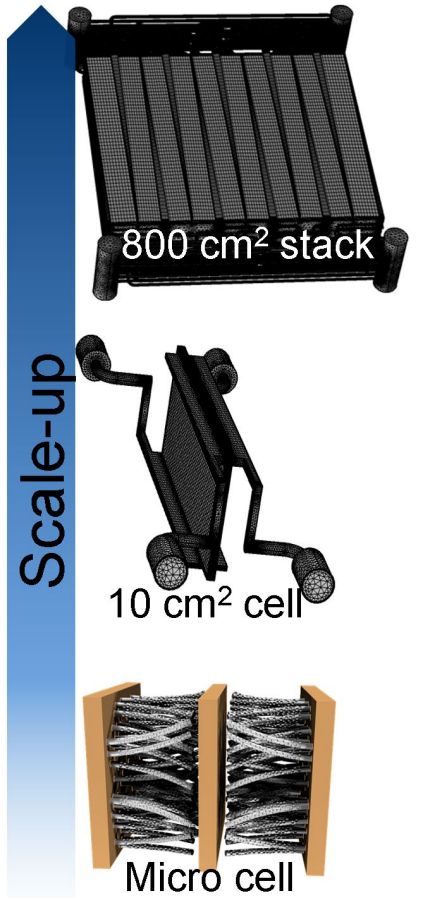

- In-situ parameter extraction protocol through small symmetric cell testing for mass transfer coefficient, charge transfer coefficient, reaction rate constant, etc.

- Validated the parameter extraction protocol and multi-physics model for small cell and large cell for the Vanadium system
- Predicted the large cell/stack performance

In-situ parameter extraction protocol

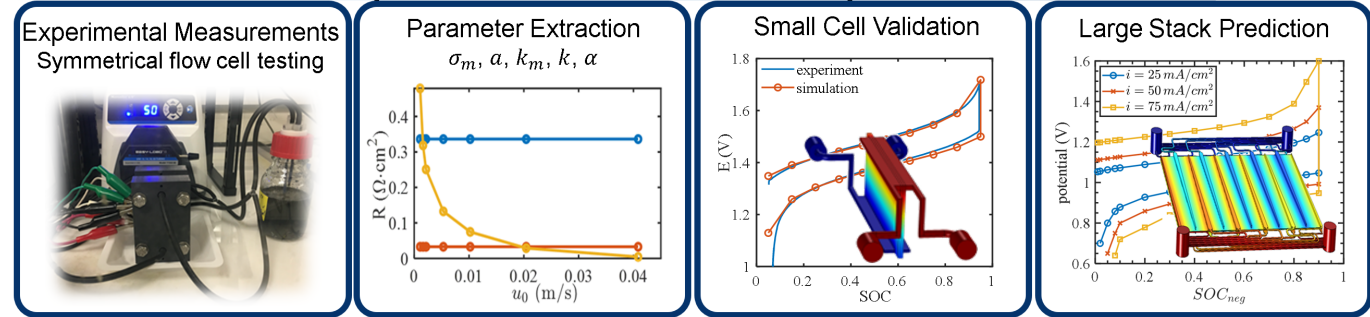

Chao Zheng, et al. Journal of The Electrochemical Society, 170, 3 (2023)
Chao Zheng, et al. Journal of The Electrochemical Society, 169, 2 (2022)
Yucheng Fu, et al. Journal of Power Sources, 556, (2022)
Jie Bao, et al. Advanced Theory and simulations, 3, 2, (2019)

σ_m decrease at rate $f(t)$
 a decrease at rate $g(t)$
 k_n decrease at rate $h(t)$
 :



Degradation Mechanism Quantification and Long-Duration Performance Prediction

Experiment Data

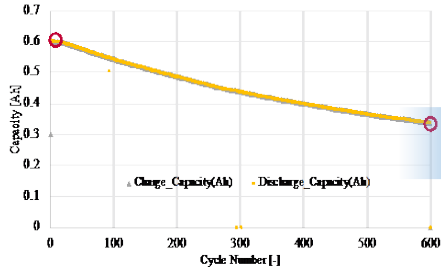

Various Degradation Mechanisms

σ_m decrease at rate $f(t)$
 a decrease at rate $g(t)$
 k_n decrease at rate $h(t)$
 :

Physics-Based RFB Model

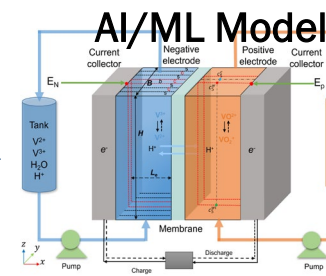

Global Optimization

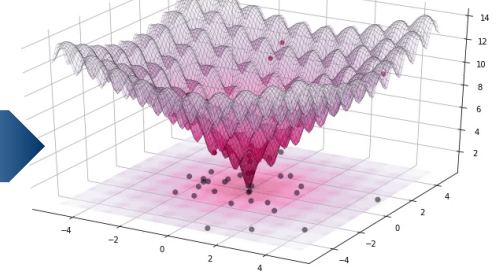

- The degraded properties can be characterized at several time snapshots for validating the model results

Degradation factor quantification

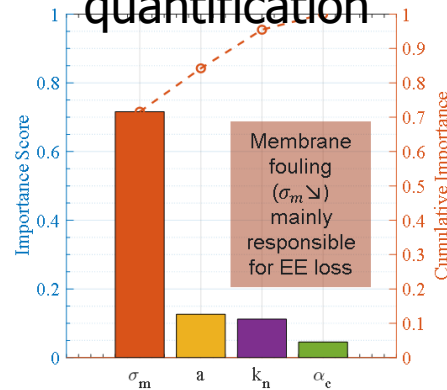

Degradation performance prediction

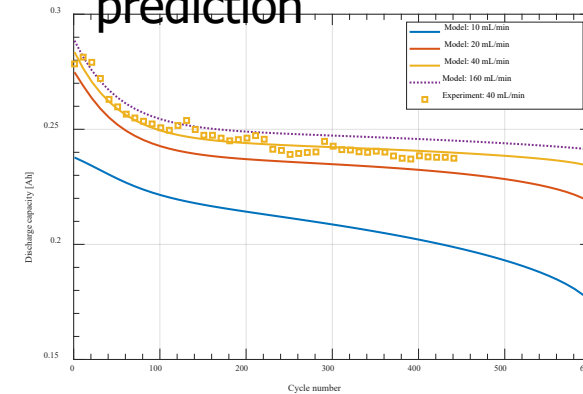

Yunxiang Chen, et al. Journal of Power Sources, 578, (2023)
 Yunxiang Chen, et al. Journal of Power Sources, 506, (2021)
 Yunxiang Chen, et al. Journal of Power Sources, 482, (2020)

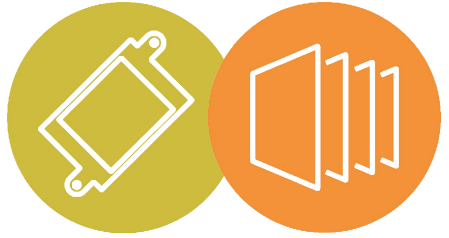

AI/ML for Large Cell and Stack Performance Estimation

- AI/ML tools for redox flow battery can incorporate physics constraints and adapt to limited datasets
 - Physics-informed neural network (PINN) is designed for requiring no training dataset
 - PINN is trained to generate the solutions that satisfy the coupled partial differential governing equations
- A modified Deep Operator Networks (DeepONets) is optimized for prediction of charging/discharging voltage at different SOC with relatively small datasets

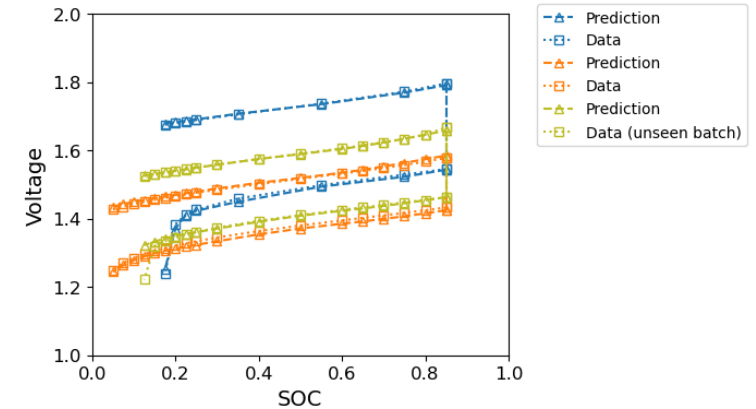
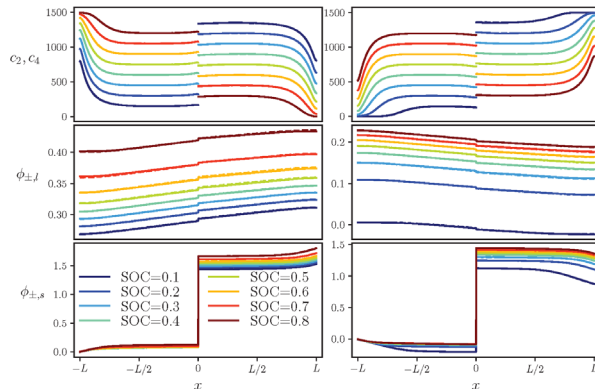
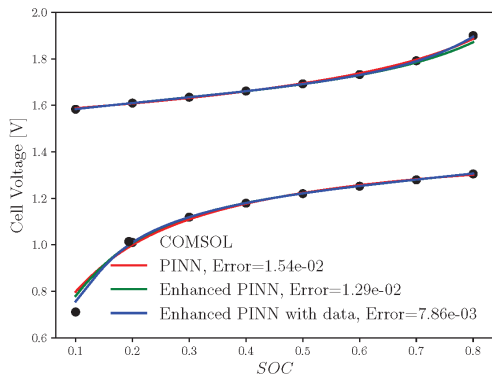

Wenqian Chen, et al. arXiv:2306.01010v1, (2023)
Amanda Howard, et al. Journal of Power Sources, 542, (2022)
Qizhi He, et al. Journal of Power Sources, 542, (2022)

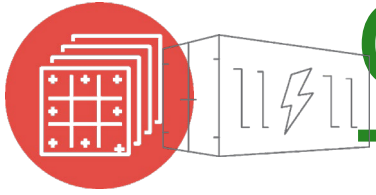

Overview Concept of the System Digital Twin for Redox Flow Battery

- The RFB system digital twin is the surrogate of the real deployed system
- Continuously receive the streaming data
- Automatically calibrate to best match the streamed data
- Predict the system future performance
- Predict and visualize the detailed performance of each cell and stack
- Predict and visualize the degradations of cell's components

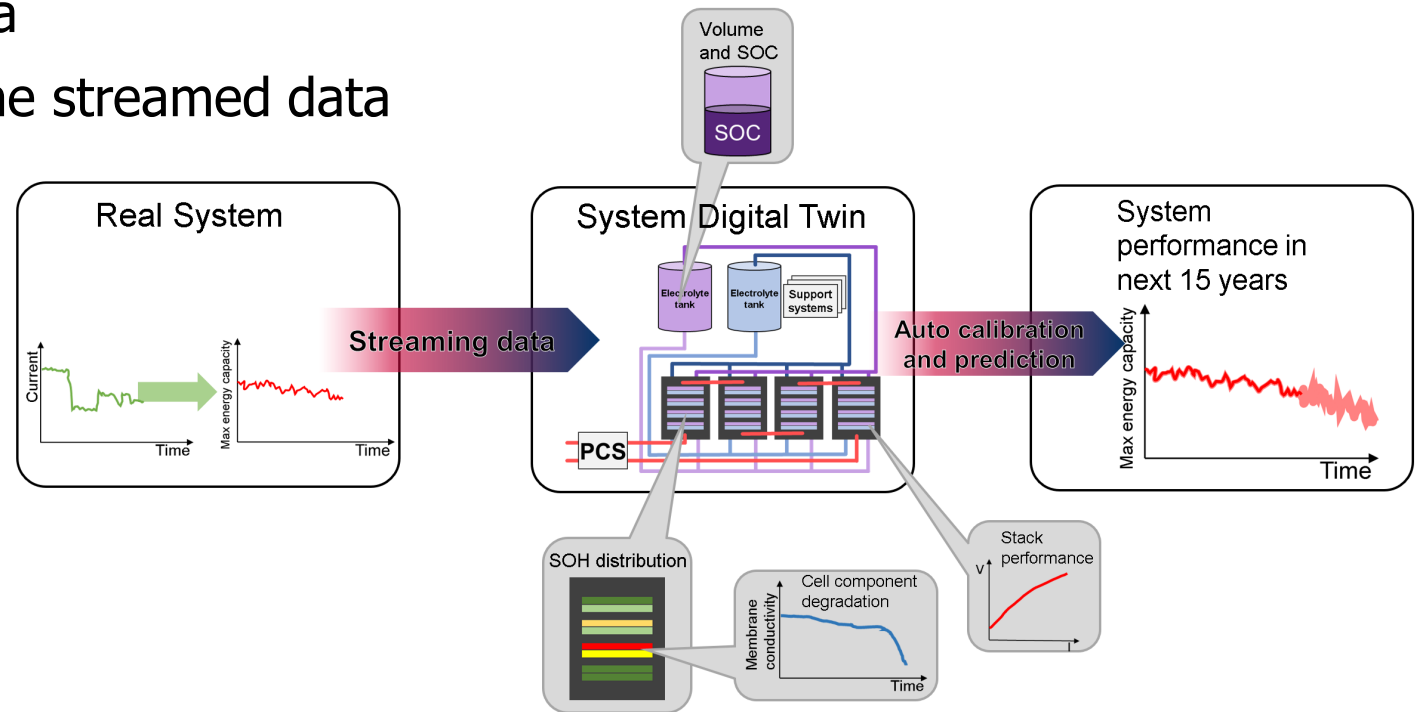

Vilayanur Viswanathan, et al. Journal of Power Sources, 247, (2014)

Soowhan Kim, et al. Journal of Power Sources, 237, (2013)

David Stephenson, et al. Journal of The Electrochemical Society, 159, (2012)

3RD
ANNUAL

ENERGY STORAGE
GRAND CHALLENGE SUMMIT

Accelerated Life Testing

– Flow Batteries and Li-ion Systems

Kevin L. Gering, PhD (INL)

July 27, 2023

Contributors:

PNNL: Vincent Sprenkle, Vilayanur Viswanathan, Wei Wang, Jie Bao

NREL: Kandler Smith

ORNL: Srikanth Allu

INL: Bin Li, Eric Dufek, Kaleb Houck



ENERGY STORAGE
GRAND CHALLENGE
U.S. DEPARTMENT OF ENERGY

Premise

- Accelerated Life Testing (AT) supports accelerated aging diagnostics and life predictions, especially for long-term applications such as LDES, allowing quicker BESS technology maturity, investment and market entry.
- “Acceleration” is achieved through
 1. Accelerated testing protocols that focus on intended field applications, which compresses the timeframe for data capture,
 2. Accelerated life predictions enabled by combinations of physics and AI.
- Physics-guided machine learning (PG-ML) serves as our engine for accelerating battery aging diagnostics and predictions, while supporting ROVI objectives.

ESGC mantra: Innovate Here, Make Here, Deploy Everywhere

Fundamental Considerations

- Design AT to have relevance to intended BESS field conditions (e.g., LDES Lab Call, DE-FOA-0002867 Topic 1 Goal: sustained operation of $\geq 100\text{kW}_{AC}$ for ≥ 10 hr)
- AT should
 - cover both cycle-life and calendar-life conditions,
 - avoid introducing new aging mechanisms or damage that would otherwise not be seen in the LDES applications,
 - be aware of particular rate capabilities and aging tendencies for the chosen BESS chemistries,
 - use a higher data sampling rate for early-phase testing (say, first third of testing) to capture critically important early-life trends.
- Connect AT Experimental Design to needs of PG-ML
 - Choice of data types, dataset sizes, methods to detect aging mechanisms, decision tree architectures, choice of training vs test sets, etc.
- Cell-to-string (module)-to-system testing transitions, in support of ROVI, ML, etc.

Overarching Life Prediction Challenge:

Long-term aging predictions based on early-life data

Per DE-FOA-0002867 (OCED) "...ROVI targets development of accelerated testing and validation methods for new LDES technologies that will yield **15+ years of investment grade performance projections with only 1 year or less of data required.**"

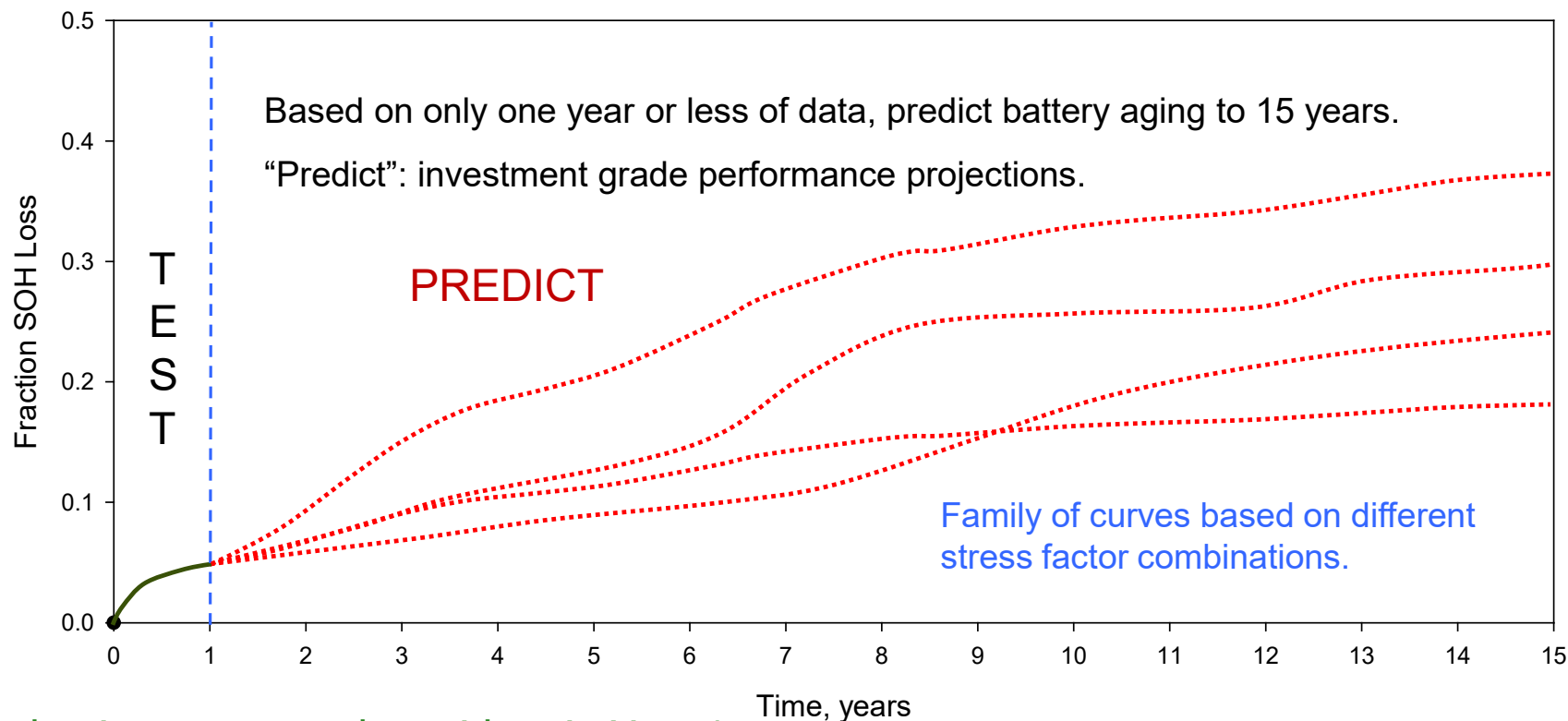

Considerations:

- Some aging mechanisms may not be evident in Year 1.
- We foresee the need for some physical metadata for LDES test articles to support physics models.
- AI will be valuable for discerning impact of multiple combined stress factors.

Part 1: Flow Batteries

What accelerated test protocols will yield 15+ years of investment grade performance projects with 1 year or less of data?

- Assumption: We cannot apply accelerated test procedures to fielded systems

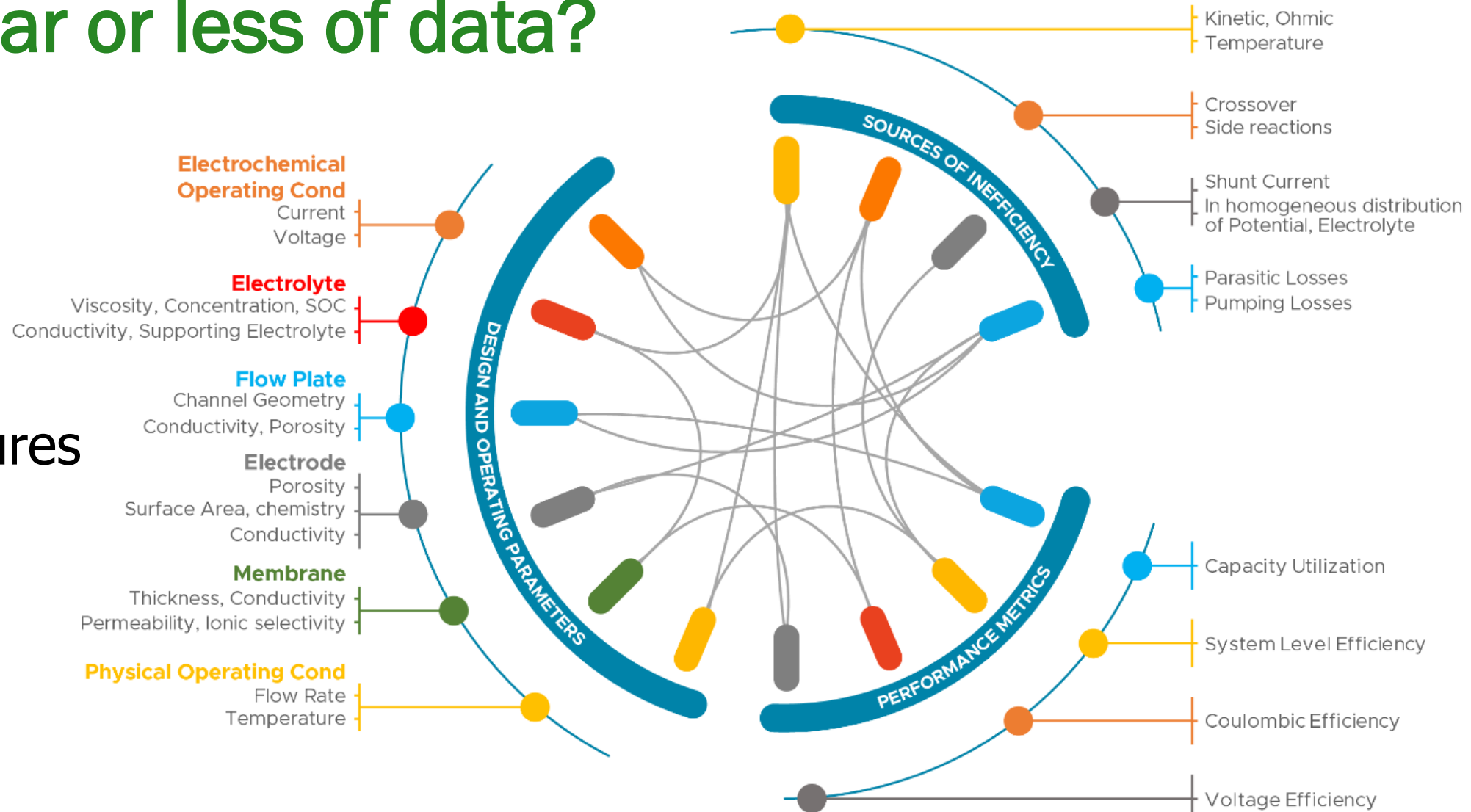

CHALLENGE 1: Chemistries/architectures drive different lab accelerated tests. Must down select

NON-FLOW

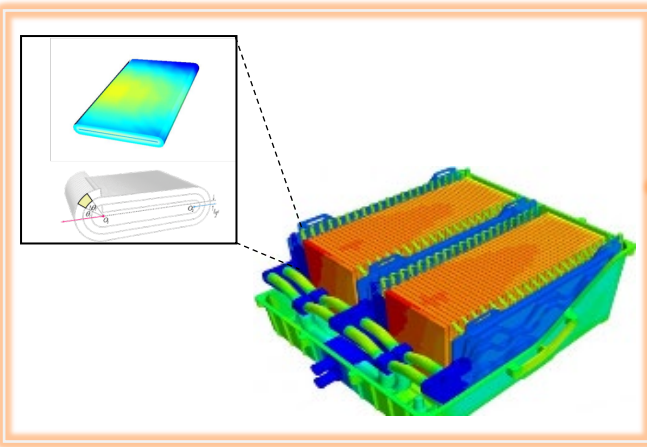

- COMMON: ROVI workflows/data/tools
- NON-FLOW: Validate complete pipeline from lab-accel.-testing to systems-level prediction
- FLOW: ROVI AT expected to build on dual-flow traditional RFB already ongoing at labs

FLOW

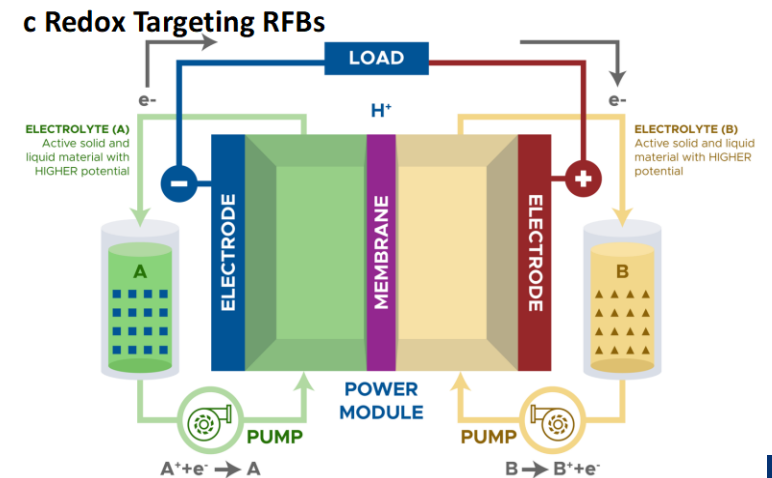
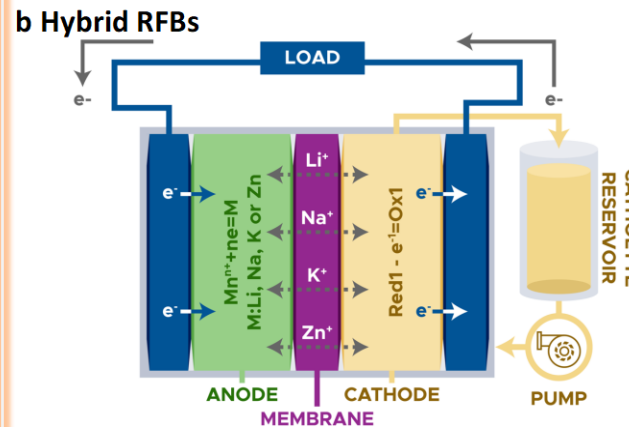
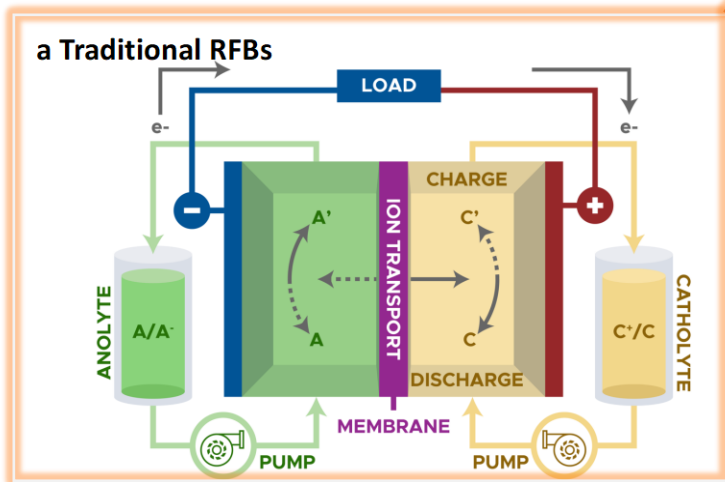

Materials



Small stack

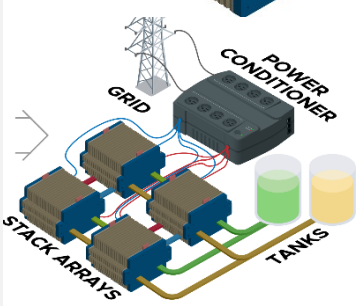
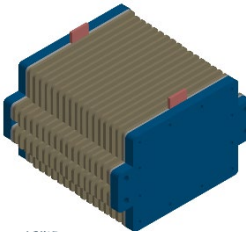
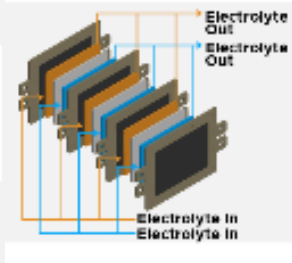

MW systems

CHALLENGE 2: How do we scale lab accel. tests to commercial systems?

- Conduct lab accelerated tests at “small stack” level (3- to 5-cell, $\sim 100 \text{ cm}^2$)
 - Observe/accelerate most echem degradation modes
- Models must extrapolate stack-size & system-level effects
 - Crossover
 - Shunt current
 - Heterogeneities (concentration/species/potential/current)
 - Balance of plant (complimented by field data)

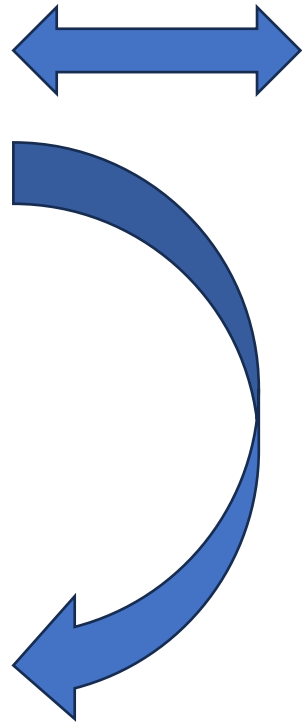

PNNL's Accelerated Stressor Lifetime Testing (ASLT) for VFRB

- ASLT protocol screens, selects and runs accelerated tests using 4 stressors^{1,2}
- Design of experiment includes both
 - Single stressor
 - Multi stressor (synergetic effect)
- Can be correlated with real device lifetime
- Reference electrode decouples cathode, anode, and membrane contributions^{3,4}

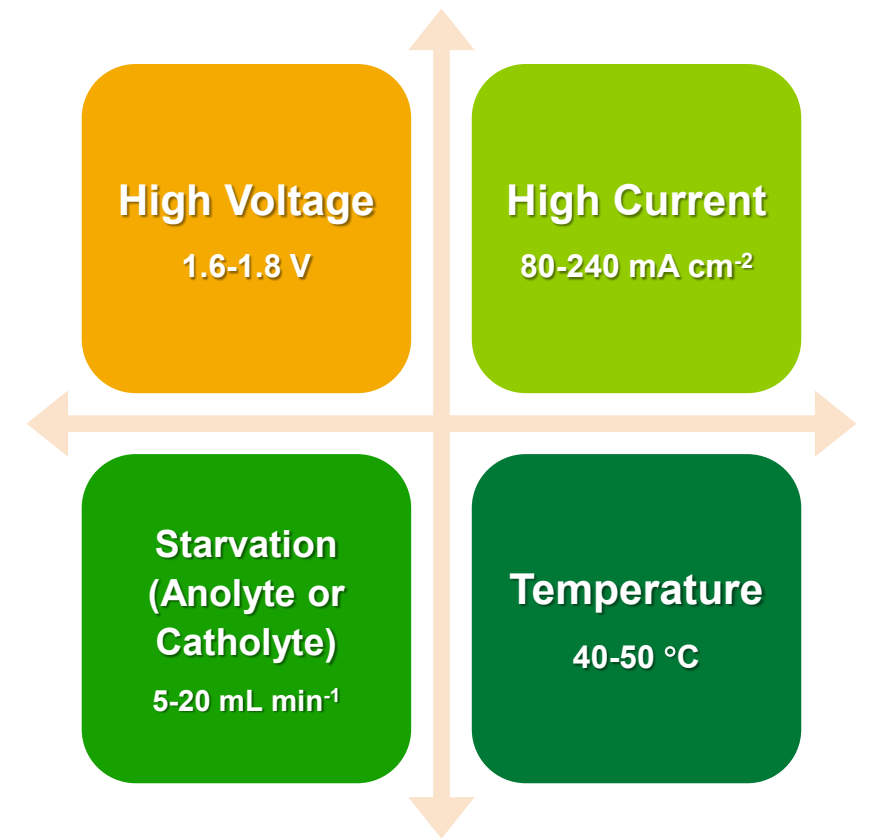

*Stressor screening and selection
by literature study and preliminary experiments*

1. "In-situ Reliability Studies of Vanadium Redox Flow Batteries: High Voltage Stressor" 2019 DOE OE Energy Storage Program Peer Review Poster, and 2020 ESS Safety & Reliability Forum Poster.
2. "In-situ Reliability Investigations of Vanadium Redox Flow Batteries: An Ultra-Stable Reference Electrode Development & High Current Stressor Study" 2021 DOE OE ES Program Peer Review Poster.
3. Q. Huang, B. Li, C. Song, Z. Jiang, A. Platt, K. Fatih, C. Bock, D. Jang and D. Reed, J. Electrochem. Soc., 2020, 167, 160541
4. Q. Huang, C. Song, A. Crawford, Z. Jiang, A. Platt, K. Fatih, C. Bock, and D. Reed, RSC Adv., 2022, 12, 32173

Part 2: Li-ion Systems

Summary of Stress Factors for Li-ion AT (LDES)

- Stress factors for Li-ion systems have been well studied, but will require review for new chemistry designs such as electrode architectures and electrolytes.
- We seek to accelerate normal aging pathways (at least 3-4X) without introducing new mechanisms. We also seek to avoid undue battery polarization in AT data.

Stress Factor	Intended Consequences	Unintended Consequences
Higher Temperature	Increase kinetics of aging mechanisms	Gas formation; electrolyte dryout
Higher SOC	Increase kinetics of aging mechanisms	Gas formation; electrolyte dryout, lithium plating
More severe cycling conditions	Increase impact of higher current density on mechanisms	Could introduce polarization hysteresis that compromises data
More frequent cycling	Increase impact of higher coulomb count on mechanisms	Could introduce polarization hysteresis that compromises data
Pressure management	Can moderate aging rates	Too little: gas formation

Assignment of AT Stress Factors will depend on LDES Awardees' Li-ion chemistries.

Hierarchy of Testing/Data: PG-ML for LDES

IDEALIZED

Clean Monolithic Lab Data

Each cell group is defined by one set of test conditions.

Lab Data with one or two field parameters (non-random)

Non-random variance of conditions is permitted in some cell groups.

Field Data with one or two parameters (cycle-life conditions non-random), but with random Cal-life inputs.

Frequency and duration of Cal-life is random. Cycle-life conditions (duty cycle) is set.

REALISTIC

Field Data with two or more parameters, but with random Cycle-life and Cal-life conditions.

Randomness is found in both frequency and magnitude of cycle-life and cal-life.

- Testing will benefit from a diversity of test articles (cell, string (module), system) in terms of providing a deeper data pool for ML.
- Data produced by above scenarios may vary in capture rate, type and fidelity. RPT (if available) versus cycle-by-cycle (CBC) is a prime consideration. *Connecting data to ROVI and ML architectures is a priority.*
- Thoughtful inclusion of physics models will alleviate data gaps and help determine hierarchy of aging stress factors (to aid in ML decision tree optimization).

Cell Reports Physical Science

CellPress OPEN ACCESS

Article

Accelerated battery life predictions through synergistic combination of physics-based models and machine learning

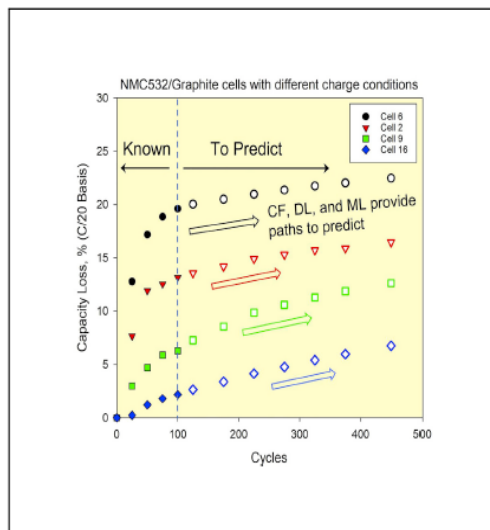

Kim et al. report methods to accelerate prediction of battery life on the basis of early-life test data. This allows timely decisions toward managing battery performance loss and related use conditions. This approach provides insights into battery design and operation strategies and may further improve robustness and reliability of batteries.

Sangwook Kim, Zonggen Yi, M. Ross Kunz, Eric J. Dufek, Tanvir R. Tanim, Bor-Rong Chen, Kevin L. Gering

kevin.gering@nl.gov

Highlights

Battery life prediction is accelerated on the basis of using early-life capacity loss data

Deep learning, advanced curve fitting, and machine learning are compared

Methods are demonstrated on NMC/graphite cells tested for fast charge

Small percentage deviations are seen between extended test data and models

Kim et al., Cell Reports Physical Science 3, 101023 September 21, 2022 © 2022 Elsevier Inc. <https://doi.org/10.1016/j.xcrp.2022.101023>

AT/Modeling Previous Work (one example)

Our Methods Showcased Accelerated Predictions focusing on LLI as the predominant aging mechanism, using SRE* basis

Sangwook Kim, Zonggen Yi, M. Ross Kunz, Eric J. Dufek, Tanvir R. Tanim, Bor-Rong Chen, and Kevin L. Gering

Cell Reports Physical Science 3, 101023 (August 2022)

- We demonstrate three methods by which SRE parameters are early assessed.
- NMC/graphite cells used for XCEL fast charge tests are evaluated.
- For cases dominated by loss of lithium inventory (LLI) we can predict end-of-test capacity loss using less than three weeks of data.
- In many cases, predictions are within 5%–10% relative error and to within 1%–2% absolute error of observed performance.

*Sigmoidal rate expression

Accelerated Testing: Reflections & The Future

- ASPIRATION: Predict 15+ years of investment-grade perf. with ≤ 1 year AT data
- FLOW: $\ll 10$ years experience
 - Example VFRB studies underway at PNNL
 - Adapt Li-ion experience to flow: Degradation Modes + Accel. Test + Physics models + ML
- LI-ION: 30 years since commercialization (10 years at \sim scale)
 - ACHIEVEMENTS: Life prediction possible in ~ 1 year using reduced-order models + ML. Li-ion systems are bankable, contractual levers have reached some maturity
 - NEEDS: \downarrow cost/time + \uparrow accuracy. Broad adoption of standard methods/tools. Better understanding of long-term degradation physics and linked mechanisms.
- NEXT for ROVI Lab Team
 - Survey available models, tools, and priority datasets
 - Coordinate approach with DOE & LDES awardees
 - What (sub-scale) hardware will be available for lab testing?
 - What metadata is available for LDES test articles?
 - What life-predictive tools and accelerated testing datasets are most valued by LDES performers?

