

# High-Silicon Steel Sheet by Single Stage Shear-Based Processing

DE-EE0007868

Purdue University/M4 Sciences/PNNL

06/15/17 – 12/31/20

---

Srinivasan Chandrasekar, Purdue University

Kevin Trumble, Purdue University

James Mann, M4 Sciences

Aashish Rohatgi, PNNL

U.S. DOE Advanced Manufacturing Office Virtual Program Review Meeting

June 2-3, 2020

*This presentation does not contain any proprietary, confidential, or otherwise restricted information.*

# Overview

**Project Title:** *High-Silicon Steel Sheet by Single Stage Shear-Based Processing*

## **Timeline:**

**Project Start Date:** 06/15/2017  
**Budget Period 2 End Date:** 12/31/2020  
**Project End Date:** 12/31/2020

## **AMO MYPP Connections:**

- Next Generation of Electric Machines II- Key Enabling Technologies
- Low-Loss Electrical Steel Manufacturing
- Improve electric motor efficiency
- Increase US manufacturing productivity and efficiency

## **Barriers and Challenges:**

- Low workability of high-Si steels
- Long lead-times (materials, equipment, tooling)
- Paradigm shift in materials processing

## **Project Budget and Costs:**

Budget	DOE Share	Cost Share	Total	CS %
Overall Budget	\$1,500,000	\$179,147	\$1,679,147	10.7%
Approved Budget (BP-1&2)	\$1,500,000	\$179,147	\$1,679,147	10.7%
Costs as of 3/31/20	\$755,698	\$99,172	\$854,861	11.6%

## **Project Team and Roles:**

- ***Purdue:*** process development and characterization
- ***M<sub>4</sub> Sciences:*** machine/process design
- ***PNNL:*** sheet characterization
- ***Seco Tools:*** tooling development
- ***Strategic Partners***

# Project Objective

- Scale up shear-based cutting process for producing sheet of low-workability alloys in a *single step* of deformation
- Apply new process to high-Si, low-loss electrical steels (6.5 %Si equivalent performance)
- Enable **cost-effective** production of high-Si electrical steel sheet for increased efficiency of electric motors

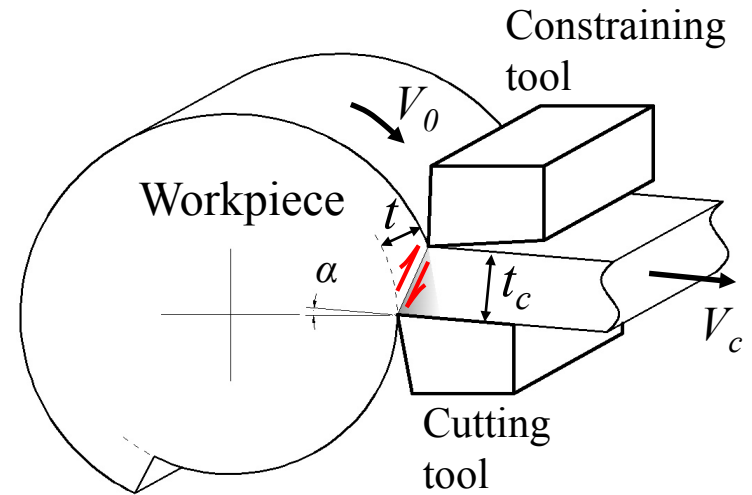

*Hybrid Cutting-Extrusion (HCE)*

Potential saving of 11,865 GWh/Yr (0.44% of total US electricity) if deployed across all electric motor sectors (DOE AMO, 2016)

# Technical Innovation

Virtually all metal alloy sheet is produced by rolling processes

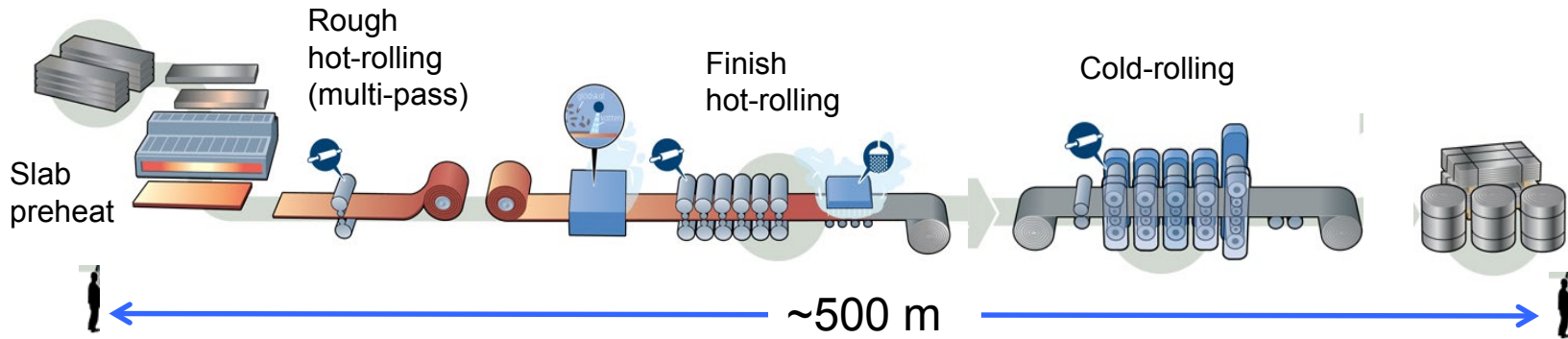

Multi-step reduction, large complex infrastructure, energy intensive

## Hybrid cutting-extrusion (HCE)

Innovative application of machining for materials manufacturing

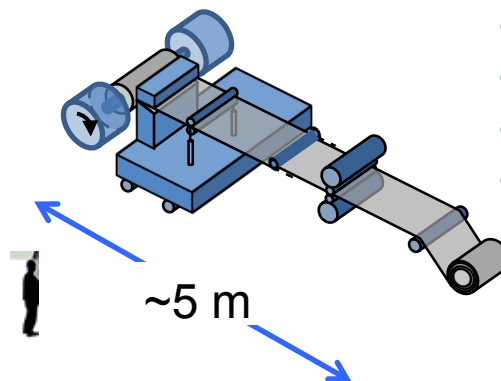
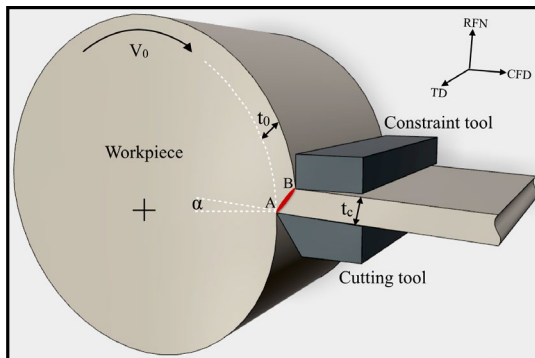

- Single-step process at high rate ( $>1$  m/s)
- Local deformation/adiabatic heating
- Compact infrastructure
- **$> 50\%$  process energy savings**



# Technical Approach

## Phase 1 (50-mm wide strip)

### Small scale HCE

- Fe-4Si, Fe-6Si
- Al alloys, brass
- Background IP

### Alloy development: FeSi-X

- Processing in HCE
- Format for workability

### Manufacturing Development

- Equipment/tooling/process
- HCE and FM+CR
- Range of alloys
- New mfg science & IP

Process scaling

Stage 1 scaling: 50 mm x 0.3 mm

## Phase 2 (150-mm wide strip)

### Process scaling – 2 stages

- Equipment design
- Prototype sheet/strip
- Model alloys (Al, Brass)
- New hi-Si alloy Fe-4Si-4Cr

### Process Capability

- Target scale
- Quality
- Material properties
- Processing characteristics

Pre-production

Stage 2A: 100 mm x 0.3 mm

Stage 2B: 150 mm x 0.5 mm

# Technical Approach

---

## Risks and unknowns:

- Tool design and performance (large size carbide tools, edge geometry, life)
- Equipment and workpiece designs
- Sheet quality attributes and stampability
- Long industry lead times (custom alloy workpieces and large tools)

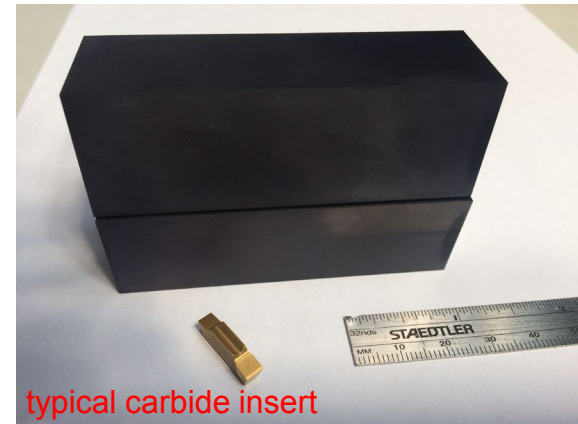

Large size (first-of-a-kind) carbide HCE tools

## Unique execution attributes:

- Prior success in commercializing materials processing technologies from university research (*M<sub>4</sub> Sciences and Purdue*)
- *Partnership with leading machine tool producer (Seco Tools-Sandvik and Purdue)*
- Prior partnership in processing science of HCE (US Freedom Car Program) for magnesium alloys (*PNNL and Purdue*)

# Results and Accomplishments

## Milestones (2019-20)

### M<sub>2</sub> Stage-1 process: 50-mm wide strip

- Fe<sub>4</sub>Si<sub>4</sub>Cr alloy strip produced (rotary HCE)
- microstructure and surface characterization completed; magnetic properties in progress

### M<sub>3</sub> Stage-2 process: 150-mm wide strip

- design of linear HCE process completed (D<sub>3</sub>)
- machine purchase in progress (installation July 2020)

## Key Result

- First wide (~50-mm) strips of Fe<sub>4</sub>Si<sub>4</sub>Cr produced
- Surface finish < 1 μm Sa (superior to cold rolled)
- Unique large carbide tools developed

## To be completed by end of project

- Produce 150-mm strips of Fe<sub>4</sub>Si<sub>4</sub>Cr alloy
- Verify surface quality and mechanical properties
- Demonstrate ≥50% reduction in core loss vs. Fe-3.2Si (M<sub>19</sub>)

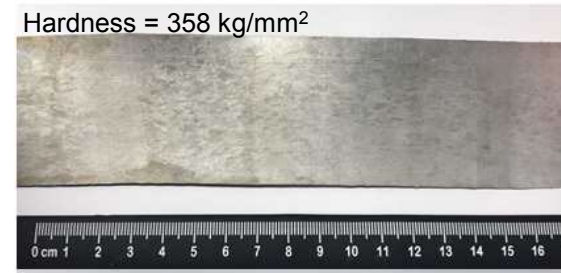

48-mm wide Fe<sub>4</sub>Si<sub>4</sub>Cr strip

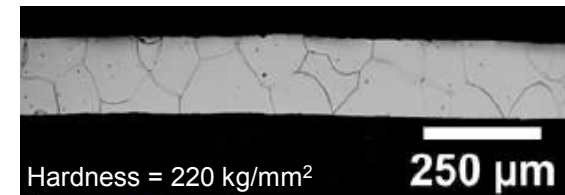

Annealed strip grain structure

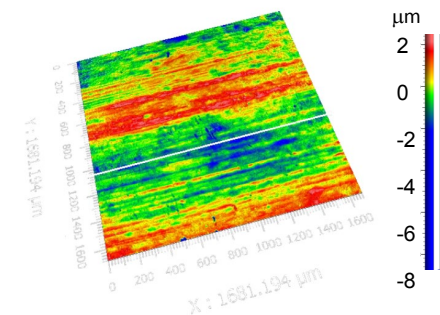

Surface roughness by optical profilometry 0.7-1.0 μm Sa

# Transition

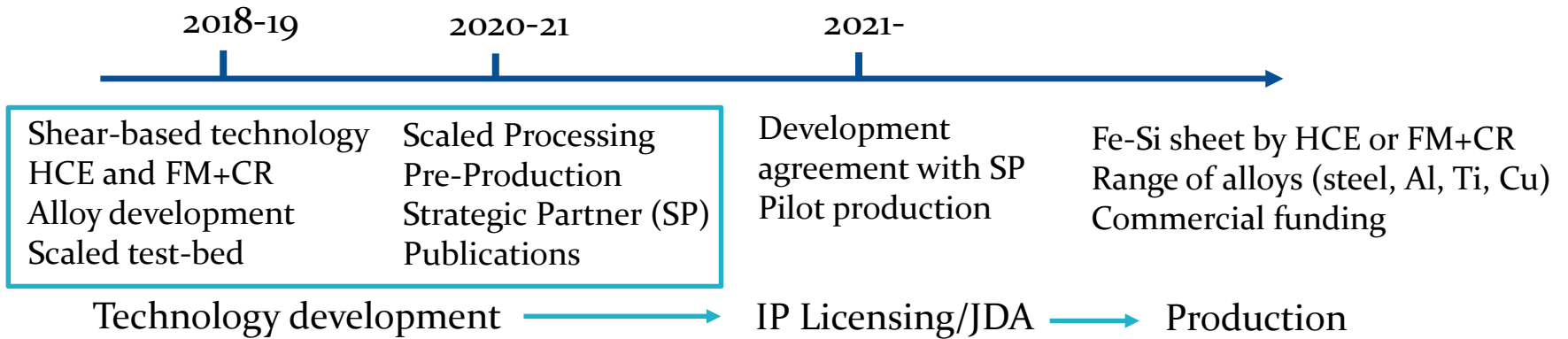

Rotary configuration  
(50-HP lathe)



Linear configuration  
(Modified double-column machining center)

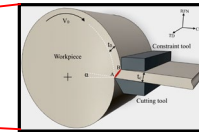
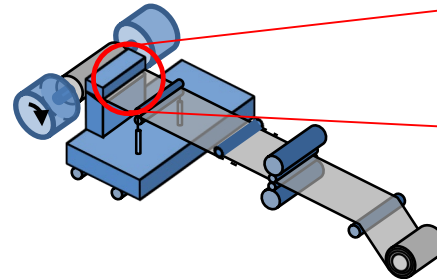

Hybrid cutting-extrusion

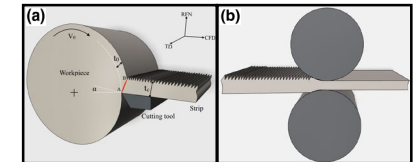

Free-machining + cold rolling

- Strategy
  - Technology development
  - Strategic partners – markets engaged early adopters (Seco-Sandvik, Spirit, General Cable, Arconic)
  - IP licensing and commercialization via Purdue/OTC
  - Pursue funding for production and commercialization