



The Boeing Company
Santa Susana Field Laboratory
5800 Woolsey Canyon Road
Canoga Park, CA 91304-1148

Via FedEx

October 31, 2012
In reply refer to SHEA 112600

Mr. David Hung
Regional Water Quality Control Board
Watershed Regulatory Section
320 West 4th Street, Suite 200
Los Angeles, CA 90013

Subject: October 2012 Update: Storm Water Pollution Prevention Plan (Revision 7) for The Boeing Company, Santa Susana Field Laboratory, Unincorporated, Ventura County, CA (NPDES NO. CA0001309, CI NO. 6027)

Dear Mr. Hung:

The Boeing Company is submitting the newly revised Storm Water Pollution Prevention Plan (SWPPP) for the Santa Susana Field Laboratory (SSFL) facility located in the Simi Hills, an unincorporated area of Ventura County, California. This SWPPP was updated to fulfill the Regional Water Quality Control Board's requirements of Order No. R4-2010-0090, Waste Discharge Requirements for the Boeing Company, Santa Susana Field Laboratory (NPDES CA0001309) and Monitoring and Reporting Program No. 6027, dated July, 19, 2010 (NPDES Permit). The SWPPP was updated based upon facility changes, revisions to figures and updated significant material inventory.

In addition, SWPPP incorporates the following updated plans required by the NPDES Permit: Significant Material Inventory; Best Management Practices Plan (BMPP) and Pollution Minimization Plan (PMP); and Spill Contingency Plan and Accidental Discharge and Contingency Plan.

Should you have any questions, please feel free to contact Mr. Paul Costa at (818) 466-8778.

Sincerely,

Thomas D. Gallacher
Director
Environment, Health and Safety
Santa Susana Field Laboratory

TG:PC:jag

Attachment: Storm Water Pollution Prevention Plan

cc: Ms. Cassandra Owens (LARWQCB)
CSU-Northridge Library
Simi Valley Library
Los Angeles Platt Library

**STORMWATER POLLUTION PREVENTION PLAN
FOR THE
SANTA SUSANA SITE**

Prepared for:

**THE BOEING COMPANY
SANTA SUSANA SITE**

Prepared by:

**MWH
618 Michillinda Ave, Suite 200
Arcadia, CA 91007**

Revision 7: OCTOBER 2012

TABLE OF CONTENTS

<u>Section</u>	<u>Page No.</u>
1.0 INTRODUCTION AND PURPOSE	1-1
1.1 Introduction	1-1
1.2 Purpose	1-1
2.0 POLLUTION PREVENTION TEAM (G.III.A)	2-1
3.0 FACILITY DESCRIPTION	3-1
3.1 Site Location	3-1
3.2 Santa Susana Site Description	3-1
3.3 Site Areas	3-1
3.4 Stormwater Drainage System and Outfalls	3-2
3.4.1 Surface Water Drainages	3-2
3.4.2 Surface Water Ponds	3-3
3.4.3 Surface Water Monitoring Locations	3-4
3.5 Stormwater Treatment and Conveyance System.....	3-5
3.6 Site Maps of Active Areas (G.IV.A – G.IV.E).....	3-7
3.7 Inactive and Non-Operational Areas	3-7
4.0 SIGNIFICANT MATERIALS (G.VI)	4-1
4.1 Potential Pollution Sources (G.VI.A)	4-1
4.1.1 Remediation Processes (G.VI.A.1) and Waste Handling and Storage Areas (G.VI.A.2)	4-1
4.1.2 Dust and Particulate Generating Activities (G.VI.A.3)	4-3
4.1.3 Significant Spills and Leaks (G.VI.A.4).....	4-3
4.1.4 Non-Stormwater Discharges (G.VI.A.5)	4-4
4.1.5 Recent Potential Soil Erosion & Dust Generation Areas (G.VI.A.6)	4-4
5.0 ASSESSMENT OF POTENTIAL POLLUTION SOURCES (G.VII)	5-1
5.1 Potential Sources of Pollutants	5-1
5.1.1 Active Areas	5-1
5.1.2 Inactive and Non-operational Areas	5-1
5.1.3 Permitted Non-Stormwater Discharges	5-1
5.2 Pollutants with Potential to be Present.....	5-1
6.0 STORMWATER MANAGEMENT AND CONTROLS	6-1
6.1 BMPs.....	6-1
6.2 BMP Implementation (G.VIII)	6-1
7.0 REFERENCES	7-1

FIGURES

Figure No.

- Figure 1 – Site Location Map
- Figure 2 – Site Map
- Figure 3 – Site Map with Stormwater Drainage Systems and Outfalls
- Figure 4 – Area I Key Map –
- Figure 4A – Area I - Sewage Treatment Plant No. I (Inactive)
- Figure 4B – Area I - Fire Station (Bldg 319)
- Figure 4C – Area I - Treatment System Chemicals (407 & 408 Yard) & Field Test Kit Chemicals/Reagents (407 Yard) Storage Area
- Figure 4D – Area I - Groundwater Extraction Treatment System (GETS)
- Figure 4E – Area I - Outfall 011 Stormwater Treatment System (SWTS)
- Figure 5 – Area II Key Map
- Figure 5A – Area II - Alfa Test Stand (Inactive)
- Figure 5B – Area II - Bravo Test Stand (Inactive)
- Figure 5C – Area II - Alfa-Bravo Fuel Farm (Inactive)
- Figure 5D – Area II - Delta Test Facility (Inactive)
- Figure 5E – Area II - Storage Propellant Area (SPA) (Inactive)
- Figure 5F – Area II - Laser Lab (Building 2203) and Expendable Launch Vehicle (ELV) (Building 2206)
- Figure 5G – Area II - Rocket Nozzle Test Facility (RNTF) - Coca Area and Vacuum Ball (Inactive)
- Figure 5H – Area II - NASA Hazardous Waste Yard
- Figure 6 – Area III Key Map
- Figure 6A – Area III - Outfall 018 Stormwater Treatment System
- Figure 7 – Area IV Key Map
- Figure 7A – Area IV - Radioactive Material Handling Facility (RMHF) (AOC)
- Figure 7B – Area IV - Laser Building (No. 9) and Building 4100 (Inactive)
- Figure 7C – Area IV - Sodium Pump Test Facility (SPTF)/Component Handling and Cleaning Facility (CHCF) (Inactive)
- Figure 7D – Area IV - Building 4055 (Inactive)
- Figure 7E – Area IV - Sodium Waste Treatment Facility (Building 4133) (Inactive)
- Figure 7F – Area IV - DOE Hazardous Waste Yard
- Figure 8 – Potential Soil Erosion, Dust Generation, and Impervious Areas

APPENDICES

Appendix

- A Waste Discharge Requirements for The Boeing Company, Santa Susana Field Laboratory (NPDES No. CA0001309) and Monitoring and Reporting Program No. 6027
- B Best Management Practices Plan (BMPP) and Pollutant Minimization Plan (PMP) (Non-Stormwater)
- C Significant Materials Inventory
- D California Stormwater Handbook Best Management Practices Factsheets
- E SSFL Spill Prevention and Response Plan and Accidental Discharges Contingency Plan

SECTION 1.0 INTRODUCTION AND PURPOSE

1.1 INTRODUCTION

This Stormwater Pollution Prevention Plan (SWPPP) was prepared for the Santa Susana Field Laboratory ('Santa Susana Site' or 'Site'), located in Simi Hills, Ventura County, California. This SWPPP was prepared in general accordance with the State of California General Industrial Stormwater Permit (No. CAS000001) (General Permit) SWPPP requirements. The Boeing Company (Boeing) also operates under a site-specific permit for the discharge of stormwater. Therefore, this SWPPP contains all of the elements required for a SWPPP designed to comply with the General Permit including those elements that are required in the site-specific National Pollutant Discharge Elimination System (NPDES) Permit (Order no. R4-2010-0090, NPDES No CA0001309, CI No. 6027) dated June 3, 2010, and effective July 19, 2010. Those elements include Certification of Compliance, Sampling Locations, and Sampling Plans, and are satisfied by compliance with the site-specific permit. References to the provisions of the requirements in Appendix A of the NPDES Permit are followed in this SWPPP and are included in the section headings (as an alpha-numeric designation in parentheses after the heading). The Monitoring and Reporting section of this SWPPP follows the provisions of the Monitoring and Reporting Program No. 6027 outlined specifically for the Site.

The November 2004 SWPPP was updated in December 2005, June 2006, March 2008, September 2009, October 2010 and October 2011. This SWPPP (Revision 7) describes site-specific activities, stormwater management and controls, stormwater monitoring procedures, and reporting procedures, as outlined for the Site. The NPDES Permit is included as Appendix A.

1.2 PURPOSE

The purpose of the SWPPP is to identify and evaluate sources of pollutants associated with current activities that may affect the quality of stormwater discharges and authorized non-stormwater discharges from the Site. Since March 2006 activities associated with the development of rocket propulsion systems and other programs at the Santa Susana Site ceased.

The Santa Susana Site is currently undergoing Site closure and the only operational activities are primarily related to Site closure activities, such as decommission, demolition, and restoration of the Site. Therefore, for the purposes of this SWPPP it is necessary to define the types of current activities as active, non-active, and non-operational. These are:

- Active areas include closure activities such as demolition, remediation operations and corrective measures construction.

- Non active areas consist of restored demolition areas or areas that never had Santa Susana Site operations.
- Non-operational areas include buildings and structures that are scheduled for future demolition that may or may not have significant quantities of chemical storage.

Active, non-active, and non-operational areas are currently being investigated under various characterization programs and may be subject to future remediation or corrective measures activities.

The SWPPP also identifies site-specific best management practices (BMPs) to reduce or prevent pollutants associated with current activities in stormwater discharges and authorized non-stormwater discharges. It should be noted that Project specific construction SWPPPs have been submitted for several of the active areas and these construction SWPPPs will take precedence over this site-wide SWPPP in these areas.

**SECTION 2.0
 POLLUTION PREVENTION TEAM (G.III.A)**

Boeing has identified a pollution prevention team for the Site in order to track, evaluate, and update issues covered under the SWPPP. The team members are responsible for overseeing the development, administration, and implementation of the plan, and updating the SWPPP, as required. The pollution prevention team consists of the following personnel:

Name	Department	Roles/Responsibilities
Paul Costa	Boeing, Environmental Protection Department	Environmental Program Manager
Deborah Taege	Boeing, Environmental Protection Department	Surface Water Project Manager
Gil Fuentes	Boeing, Environmental Protection Department	BMP Construction Supervisor
Dan Trippeda	Boeing, Environmental Protection Department	Construction Manager
Paul Waite	Boeing, Environmental Protection Department	Construction Manager
Bronwyn Kelly	Montgomery Watson Harza (MWH) Americas, Inc.	Surface Water Program Manager
Eric Walker	MWH Americas, Inc.	SWPPP Supervisor Lead
Shelby Valenzuela	MWH Americas, Inc.	MWHSurface Water Team Lead Project Geologist
Rick Banaga	MWH Americas, Inc.	Compliance Sampling Technician
Andrew Payne	MWH Americas, Inc.	Compliance Sampling Technician
Brian Mossman	Jacob Hefner and Associates (JHA) Environmental, Inc.	Surface Water Project Manager
Neil Smith	JHA Environmental, Inc.	SWPPP Field Manager and SWPPP inspector
Adam Goldenberg	JHA Environmental, Inc.	Compliance Sampling Lead and SWPPP inspector, Project Geologist
Stacie Aichner	JHA Environmental, Inc.	JHA Surface Water Team Lead Project Geologist

In addition, the team may assign trained individuals from various departments and/or contractors to conduct inspections and implement portions of the SWPPP.

Review and Update of SWPPP (G.X.A – G.X.F)

A copy of this SWPPP will be readily available to the regulatory agencies upon request. This SWPPP will be reviewed as part of the annual inspection as discussed in Section 7

of this document and will be updated upon significant changes at the Site, as necessary. Significant changes that may require the SWPPP to be amended are:

- Changes in the materials handling procedures;
- Changes in management practices;
- Changes in stormwater monitoring program methods or requirements; and
- Natural disasters/acts of God.

SECTION 3.0 FACILITY DESCRIPTION (G.IV)

3.1 SITE LOCATION

The Santa Susana Site is located approximately 29 miles northwest of downtown Los Angeles, California, in the southeast corner of Ventura County. The Site occupies approximately 2,850 acres of hilly terrain with approximately 1,100 feet of topographic relief near the crest of the Simi Hills. Figure 1 shows the geographic location, property lines, and surrounding communities of the Site.

3.2 SITE DESCRIPTION

The Santa Susana Site is currently undergoing Site closure activities such as demolition, remediation operations, and corrective measures construction. In March 2006 discharges associated with the development of rocket propulsion systems and other programs ceased. Prior to use as a rocket testing facility, the land at the Santa Susana Site was used for ranching and grazing. North American Aviation (a predecessor to Boeing) began using (by lease) what is now known as the northeastern portion of Area I during 1947/1948. The majority of the Santa Susana Site was acquired as part of the Silvernale property in 1954, and development of the western portion of the Santa Susana Site began soon after. Undeveloped land parcels to the south of the Santa Susana Site were acquired during 1968 and 1976, and to the north during 1998. These undeveloped portions of the Santa Susana Site were primarily historically used for ranching, grazing, and filmmaking.

3.3 SANTA SUSANA SITE AREAS

The Site is divided into four administrative areas (Areas I, II, III, and IV) and undeveloped land areas to both the north and south (Figure 2). The areas are owned and operated as follows:

Area I

Area I consists of approximately 713 acres located in the northeastern portion of the Site. Boeing owns 671 acres, and the remaining 42 acres are owned by the federal government and administered by National Aeronautics and Space Administration NASA. The 42-acre NASA property in Area I was formerly owned by the United States Air Force. Boeing operates the entire Area I, including the NASA portion. Three NPDES outfall monitoring locations are in Area I.

Area II

Area II consists of approximately 410 acres located in the north-central portion of the Site. Area II is owned by the federal government, administered by NASA and operated by Boeing. There are five NPDES outfall monitoring locations in Area II.

Area III

Area III consists of approximately 114 acres and is owned and operated by Boeing. There are no NPDES outfall monitoring location in Area III.

Area IV

Area IV consists of approximately 290 acres located in the northwest section of the Site that is owned by Boeing. Portions of Santa Susana Site in Area IV have some buildings that are owned by Department of Energy (DOE). Five NPDES outfall monitoring locations are in Area IV.

Southern Undeveloped Portion

The southern portion of the Santa Susana Site is an undeveloped, open-space area that consists of approximately 1,200 acres along the southern boundary of the Site. This naturally vegetated area is owned by Boeing. Industrial activities have never been conducted in this area. Three NPDES outfall monitoring locations are in this undeveloped area.

Northern Undeveloped Portion

The northern portion of the Santa Susana Site, adjacent to Areas II, III, and IV, is an undeveloped open space area consisting of approximately 175 acres. This area is naturally vegetated and has not been used for industrial activities. This open space area is owned by Boeing.

3.4 STORMWATER DRAINAGE SYSTEM AND OUTFALLS

The following sections describe the surface water drainages and ponds at the Santa Susana Site. Figure 3 depicts the surface water drainages and divides at and near the Santa Susana Site, as well as the surface water ponds. NPDES Outfalls are also identified on Figure 3.

3.4.1 Surface Water Drainages

Surface water at the Santa Susana Site is intermittent based on stormwater runoff from rain events with the exception of the Area I Groundwater Extraction and Treatment System (GETS) which is a continuous flow at approximately 15 gallons per minute (gpm). The GETS is described in more detail in Appendix B. The Santa Susana Site is in a Mediterranean climate zone characterized by a distinct rainy season in the winter during which almost all of the annual precipitation occurs during a relatively small number of storms. Surface water exists during and shortly after each storm, after which drainages are typically dry. Surface water is conveyed offsite into one of four main drainages (i.e., the Bell Creek, Happy Valley, Northwestern, and Northern drainages).

Bell Creek Drainage

Approximately 60% of the surface water from the Santa Susana Site flows off the southern property boundary through Bell Canyon and into Bell Creek, which subsequently discharges into the Los Angeles River. NPDES Outfalls 011, 001, 018, and 002 monitor surface water discharges from the Bell Creek drainage. NPDES Outfall 011 is upstream and in the same drainage as Outfall 001, and Outfall 018 is upstream and in the same drainage as Outfall 002. Additionally, Outfall 019 GETS was added as a surface-water monitoring location in the NPDES 2010 Permit and is located downstream Outfall 001.

Happy Valley Drainage

Stormwater from the eastern portion of the Santa Susana Site flows through Dayton Canyon into Dayton Creek, and combines with Bell Creek before joining the Los Angeles River. Surface water discharges from this portion of the Site are monitored at the NPDES Outfall 008.

Northwestern Drainage

Stormwater from the northwestern perimeter of the Santa Susana Site flows northward into Meier Canyon, which subsequently discharges into Arroyo Simi. Surface water discharges from the northwestern portion of the Site are monitored at NPDES Outfalls 003, 004, 005, 006, and 007.

Northern Drainage

Stormwater from the northeastern and north-central portions of the Santa Susana Site flow into the Northern Drainage, which connects to the Meier Canyon Drainage off Site to the north of the Santa Susana Site, and subsequently discharges into Arroyo Simi. Surface water discharges from the northern portion of the Site are monitored at NPDES Outfalls 009 and 010.

Minor Drainages

Three other small parcels of the Santa Susana Site that have had no operations convey stormwater runoff through three other drainages (i.e., Runkle Canyon, Woolsey Canyon, and Eastern drainages) and subsequently discharge into the Los Angeles River.

3.4.2 Surface Water Ponds

There are four larger ponds (R-1 Pond, Perimeter Pond, Silvernale Pond, and R-2 Ponds [R-2A and R-2B Ponds]), two smaller surface water ponds (Coca Pond and the SRE Pond [typically dry]), and one excavated hole where Building 4056 was supposed to be built within the Santa Susana Site (see Figure 3). Historically, these manmade ponds were constructed for collection of industrial process water and stormwater runoff, except for the Building 4056 excavation. A brief description of the four larger water bodies is provided below.

R-1 Pond

The R-1 Pond is an approximately 3.7 million gallon capacity reservoir located along the Area I Road. It collects stormwater runoff from the eastern tributary of the Bell Creek drainage. Discharges from R-1 Pond leads to Perimeter Pond.

Perimeter Pond

The Perimeter Pond is an approximately 1.2 million gallon capacity reservoir located near the southernmost portion of the Area I Road, north of the southern undeveloped land portion. It is located downstream of the R-1 Pond. Discharge from this pond leads to the Bell Creek drainage and is monitored at NPDES Outfalls 011 and 001. Water contained in Perimeter Pond may also be pumped to the R-1 Pond.

Silvernale Pond

The Silvernale Pond is an approximately 6 million gallon capacity reservoir located in Area III and represents the largest surface water body at the Santa Susana Site. The Silvernale Pond collects stormwater runoff from the central portion of the Santa Susana Site. Discharge from the Silvernale Pond leads to the R-2B Pond as described below.

R-2 Ponds

The R-2 Ponds are comprised of two surface water collection features, the larger R-2A Pond (approximately 2.5 million gallon capacity) and the smaller R-2B Pond (200,000 gallon capacity). The R-2B Pond receives flow from the Silvernale Pond and surface water runoff from the Burro Flats area of the Santa Susana Site. The R-2A Pond receives stormwater runoff from the Coca and Delta test stands. The R-2B Pond drains to the R-2A Pond via an underground culvert. Discharge from the R-2A Pond leads to the Bell Creek drainage and is monitored at NPDES Outfalls 018 and 002.

3.4.3 Surface Water Monitoring Locations

Per NPDES 2010 Permit No. R4-2010-0090, (effective July 19, 2010), there are 16 total surface water-monitoring locations (outfalls) at the Santa Susana Site (i.e. Outfalls 001 through 014, 018, and 019). Outfalls 001 through 014, and 018 monitor stormwater discharges. Outfall 019 monitors treated groundwater discharges. No other process water is discharged at any outfalls. The list below provides an overview of the discharge sources from each outfall.

<u>Outfall Number</u>	<u>Source</u>
001	Stormwater – South Slope below Perimeter Pond
002	Stormwater – South Slope below R-2 Pond
003	Stormwater – Radioactive Material Handling Facility (RMHF)
004	Stormwater – Sodium Reactor Experiment (SRE)
005	Stormwater – Upper Former Sodium Disposal Facility (FSDF-1)
006	Stormwater – Lower Former Sodium Disposal Facility (FSDF-2)
007	Stormwater – Building 4100
008	Stormwater – Happy Valley Drainage
009	Stormwater – WS-13 Drainage (Northern Drainage)

010	Stormwater – Building 2203
<u>Outfall Number</u>	<u>Source</u>
011	Stormwater – Perimeter Pond
012	Stormwater – Alfa Test Stand
013	Stormwater – Bravo Test Stand
014	Stormwater – former Advanced Propulsion Test Facility (APTF)
018	Stormwater – R-2 Pond
019	Treated groundwater – GETS

3.5 STORMWATER TREATMENT AND STORMWATER CONVEYANCE SYSTEMS

Silvernale Pond Conveyance System (aka Stormwater Conveyance System)

The Silvernale Pond Conveyance System consists of one stormwater treatment system (SWTS), ten holding ponds, eleven pumps, and over 15,000 of feet of pipeline. The conveyance system directs water from the ponds at Outfalls 003, 004 005, 006, 007, 010, 012, 013, and R2A/R2B pond to Silvernale Pond for treatment at the Outfall 018 SWTS. Additional details regarding the conveyance system, including a layout of system pipelines, are provided in Appendix B. Details of the Outfall 018 SWTS are provided below.

Outfall 018 Stormwater Treatment System

Boeing completed construction of a high-performance SWTS at Outfall 018. The SWTS became operational for the 2011-2012 rainfall season. The process employed by the SWTS is described further below. Additional details regarding the Outfall 018 SWTS are provided in Appendix B.

Stormwater for treatment at the Outfall 018 SWTS first passes through an intake cage at R-2A Pond and/or an intake structure at Silvernale Pond. Both the cage and the intake structure support and protect the piping that travels from R-2A and Silvernale Ponds. The treatment process itself begins when one treatment pump (1,035 gpm capacity) which conveys water from Silvernale Pond through two screen filters connected in parallel. Immediately following the screen filters is Box 1, which houses injection ports for the following chemicals:

- Potassium permanganate (KMnO₄) solution – for oxidation of dissolved metals and organics
- Sodium hydroxide (NaOH) – for pH adjustment
- Hydrochloric acid (HCl) – for pH adjustment
- Aluminum sulfate (alum) – for coagulation, flocculation, and particle settling

Use of one or a combination of the above chemicals will be dependent on influent conditions.

An orifice plate is located after the chemical injection points housed in Box 1. The orifice plate induces turbulent flow and enhances mixing of the chemicals in the influent water. Once the water passes through the orifice plate, it is routed through the oxidation contact tanks (OCTs) allowing time for the potassium permanganate to oxidize dissolved metals. Effluent from the OCTs is routed to the ACTIFLO rapid clarification unit through a line that includes a feed through Box 2 that houses chemical injection ports for alum and HCl. These chemicals are continuously introduced into the water stream at this stage of the process to control coagulation and flocculation. At this stage of the treatment process, there is a separate loop with a flash mix pump and nozzle for mixing injected alum in the treatment water prior to conveyance to ACTIFLO. Once within the ACTIFLO unit, polymer is introduced for coagulation and Microsand is added to enhance ballasted flocculation.

Water is treated inside the ACTIFLO unit and the effluent from ACTIFLO is then routed to a buffer tank. Box 3, located before the buffer tank, contains injection ports for KMnO₄ for additional oxidation and NaOH for pH control. The buffer tank stores an adequate volume of water to eliminate cavitation during the next stage of the treatment process, and provides additional contact time if oxidation or pH adjustment is required.

Effluent from the buffer tank is routed to a filter feed pump (1,035 gpm capacity) that conveys the water through a series of filtration stages. The first stage is sand filtration, which is conducted in two banks of decreasing media size. Each bank consists of two skids connected in parallel. The sand filter effluent is then routed to a bank of bag filters, connected in parallel, and finally to eight granular activated carbon (GAC) vessels, also connected in parallel. Treated effluent from the GAC vessels is injected through ports in Box 4 with HCl or NaOH to control pH if necessary, prior to discharge. Finally, the effluent is either re-circulated to Silvernale Pond or discharged directly to Outfall 018.

Solids generated during treatment in the ACTIFLO unit and backwashing of the sand filters have a separate treatment system for thickening, dewatering, and final disposal. Solids generated in the ACTIFLO unit are directed into a plate settler for thickening prior to being pumped into one of two solids weir tanks for further thickening. Solids generated during backwashing of the sand filter vessels will be directed into an equalization tank and then pumped into the solids weir tanks. Supernatant in the solids weir tanks will be routed into a supernatant tank prior to being pumped back to Box 1 before the OCTs. Thickened solids in the solids weir tanks will be pumped to a mixer tank, where the solids will be thoroughly mixed (to create a suspension) prior to being fed to the dewatering unit. Solids dewatered in the dewatering unit will be hauled offsite for disposal. Filtrate from the dewatering unit will be pumped to the supernatant tank for treatment in the SWTS.

Outfall 011 Stormwater Treatment System (SWTS)

Boeing completed construction of a high-performance SWTS at Outfall 011. The SWTS became operational for the 2011-2012 rainfall season. The Outfall 011 SWTS utilizes a process and treatment train identical to the Outfall 018 SWTS (i.e. screen filtration, chemical treatment in an oxidation tank, rapid clarification via ACTIFLO, neutralization in

a buffer/oxidation tank, sand and granular activated carbon filtration, and final neutralization). Stormwater runoff from the Outfall 011 and Outfall 014 watersheds is treated by the Outfall 011 SWTS and discharged to Outfall 011. Runoff from Outfall 014 is conveyed to the Outfall 011 SWTS via vacuum truck. Additional details regarding the Outfall 011 SWTS are provided in Appendix B.

3.6 SITE MAPS OF ACTIVE AREAS (G.IV.A and G.IV.E)

There are several active areas at the Site that may be sources of potential pollutants. Active areas include closure activities such as demolition, remediation operations and corrective measures construction. Figures showing the active areas (including materials handling and storage areas) have been generated for the Site. Area I active locations are shown on Figure 4, with each location within Area I depicted on Figures 4A through 4E. Area II active locations are shown on Figure 5, with each location within Area II depicted on Figures 5A through 5H. Area III active locations are shown on Figure 6, with each location within Area III depicted on Figures 6A. Area IV active locations are shown on Figure 7, with each location within Area IV shown on Figures 7A through 7F.

3.7 INACTIVE AND NON-OPERATIONAL AREAS

The inactive areas of the Santa Susana Site are those areas where historical operations may or may not have impacted soil and/or groundwater occurred, or areas that never had Site operations. Non-operational areas include buildings and formerly used outdoor equipment/tanks that may still be present and are scheduled for future demolition. Inactive and non-operational areas are identified on the Area I through Area IV key maps (Figures 4, 5, 6, and 7).

SECTION 4.0 SIGNIFICANT MATERIALS (G.VI)

Significant materials as defined by Ventura County Business Plan requirements are included in Appendix C. This list of significant materials is updated on an annual basis, as the Site operations associated with chemical use and waste generation change. Each significant material (and the maximum and/or average quantity stored at any one time) is listed under the operational area where the material is being used, stored, and/or handled. Significant materials will continue to decrease as the Santa Susana Site continues phased Site closure activities.

4.1 POTENTIAL POLLUTION SOURCES (G.VI.A)

A brief description of potential pollution sources to stormwater that may occur or have occurred in the past is outlined below in six categories: remediation processes, material handling and storage areas, potential soil erosion areas, dust generation activities, significant spills and leaks, and non-stormwater discharges. In addition, the inactive and non-operational areas may also be a potential pollution source as stormwater comes into contact with these areas (primarily vacant buildings with paved or vegetated surfaces surrounding the buildings). Non-industrial sources, naturally occurring constituents, such as, deposits due to fire or atmospheric deposition, are not included in the discussion of this SWPPP.

4.1.1 Remediation Processes (G.VI.A.1) and Waste Handling and Storage Areas (G.VI.A.2)

No industrial processes associated with rocket engine testing or manufacturing are currently operational onsite. Boeing has installed a groundwater treatment system and two stormwater treatment systems as part of the ongoing remediation and corrective action programs onsite.

Waste handling and storage areas at the Santa Susana Site are still operational. However, the majority of waste handled at the hazardous waste storage yards is associated with investigative derived waste as a result of closure investigations and demolition activities. There are no wastes as a result of industrial operations from rocket engine testing or manufacturing. Once manifested, the waste material is shipped to the appropriate facility for disposal.

The location description of remediation systems and waste handling and storage areas are summarized below. Significant materials are presented in Appendix C.

AREA I:

Area I: Building 1319 Fire Station

The fire station currently stores and maintains fire fighting vehicles and chemicals at the Santa Susana Site. Significant materials are stored and handled at the fire station area, and are included in Appendix C. Surface water flows to the south and is monitored at Outfalls 011 and 001.

Area I: Hazardous Waste Storage Yard Building 1407

The Area I Hazardous Waste Storage Yard is located adjacent to the Safety, Health, and Environmental Affairs SHEA Building (Building 1436) in Area I and is currently the 90-day storage facility for Boeing's hazardous waste at the Santa Susana Site. All hazardous waste is stored inside or in approved containers, and is transported off Site for disposal. Significant materials are presented in Appendix C. The storage yard contains awnings for covered storage. Surface water flows to the west towards R-1 and Perimeter Ponds, then Outfalls 011 and 001.

Area I: Building 1449 – Groundwater Extraction and Treatment System (GETS)

Building 1449 is currently the active GETS facility. This facility treats extracted groundwater from Areas I, II, III, and IV of the Santa Susana Site. Hydrogen Peroxide, compressed air, calcium chloride, lubricating oil, and waste solvents for field test kits are stored at this facility. Significant materials are presented in Appendix C. Treated effluent water is monitored within Building 1449 and conveyed to Outfall 019 for discharge downstream of Outfall 001.

Area I: Outfall 011 Stormwater Treatment System (SWTS)– Perimeter Pond

The Outfall 011 SWTS is a high-performing treatment system to treat stormwater from the watershed prior to discharge as discussed in Section 3.5. Treated effluent water is monitored at Outfalls 011 and 001.

AREA II:

Area II: NASA Hazardous Waste Storage Yard

The Area II Hazardous Waste Storage Yard is currently the 90-day storage facility for NASA hazardous waste at the Santa Susana Site. All hazardous waste is stored inside or in approved containers, and is transported off Site for disposal. The storage yard contains awnings for covered storage. The storage yard is adjacent to the SPA facility in Area II. Significant materials are presented in Appendix C. Demolition of this facility is pending final disposition of the Santa Susana Site. Surface water flows to the northwest towards Silvernale Pond, then Outfalls 018 and 002.

AREA III:

Area III: Outfall 018 Stormwater Treatment System (SWTS) – Silvernale Pond

The Outfall 018 SWTS is a high-performing treatment system to treat stormwater from the watershed prior to discharge as discussed in Section 3.5. Significant materials are presented in Appendix C. Treated effluent water is monitored at Outfalls 018 and 002.

AREA IV:

Area IV: Building 4021 Radioactive Material Handling Facility (RMHF)

Building 4021 Radioactive Material Handling Facility (RMHF) is currently used for storage of compressed gases, waste oils, waste debris, waste aerosols, and mixed waste debris. In the past, this building was used for packaging and shipping of radioactive waste at the Santa Susana Site. Significant materials are presented in Appendix C. The facility is bermed and, when present, stormwater flows to the bermed containment area where it is screened for radioactive materials. Stormwater is discharged to the bermed area then discharged to the south. Excessive flow will discharge toward the north where it is monitored at Outfall 003. Surface water is monitored at Outfalls 018 and 002.

Area IV: DOE Hazardous Waste Storage Yard

The Area IV Hazardous Waste Storage Yard is currently the 90-day storage location for DOE hazardous waste. All hazardous waste is stored inside or in approved containers, and is transported off Site for disposal. The hazardous waste yard is a fenced storage area adjacent to Building 4038 in Area IV. Significant materials at this location are listed in Appendix C. Surface water flows to the southwest to Outfalls 018 and 002.

4.1.2 Dust and Particulate Generating Activities (G.VI.A.3)

Soil disturbance activities may potentially contribute to pollutants in stormwater through generation of dust and particulates. These activities may include the excavation/stockpiling of impacted soils or sediments, the excavation and backfilling of clean fill soils in excavated areas, and biotreatment of stockpiled soils. Demolition activities will include the dismantling of facility systems and removal of building structures. BMP's and water are used to suppress and control dust during soil disturbance or post demolition activities. For all projects that involve the disturbance of more than one acre of soil, a Notice of Intent (NOI) to comply with the State General Permit for the discharge of stormwater associated with construction/demolition activities is submitted, and an individual construction SWPPP is implemented and the provisions thereof are followed. Details of these activities are also described later in this document.

4.1.3 Significant Spills and Leaks (G.VI.A.4)

Two historical events where materials have spilled or leaked in significant quantities in stormwater discharges or non-stormwater discharges have occurred since April 17,

1994. The events occurred on February 26, 1998 and December 4, 2008. These events are described below.

Approximately 1,000 gallons of rocket propellant (RP-1) was spilled near the Bravo facility in Area II on February 26, 1998. The release was due to an underground pipe leak (of an “inactive” pipeline) and resulted in RP-1 flowing into the drainage channel that eventually flowed into Silvernale Pond. The inlet to Silvernale Pond was protected from the flow of RP-1 by placement of absorbent pads and booms stationed at the inlet to Silvernale Pond. Absorbent pads and booms were replaced frequently until traces of RP-1 were no longer observed. The majority of the spilled RP-1 was managed using absorbent booms, pads, and vacuum trucks and did not enter the waterway. Impacted soil near the spill area was excavated and removed for off Site disposal. The underground pipeline was abandoned in place and isolated as an “inactive” line. Documentation of the incident is maintained at the Santa Susana Site.

On December 4, 2008 approximately 300 gallons of water was released from a 20,000 gallon Baker tank containing water generated from groundwater well installation and drilling operations in the Lower Delta area (former Delta Skim Pond). The release emanated from a leak around the main tank’s drainage line and primary discharge valve. Immediate response to the spill ensued. A sample of the water was collected from the water remaining in the tank. The highest VOC concentrations were 4,500 parts per billion (ppb) Trichloroethylene (TCE). The affected spill area measured approximately 15-ft by 40-ft by 1-ft. On December 5, 2008, excavation activities ensued and approximately 20 cubic yards of soil was removed from the spill area and contained in a roll-off bin. The waste was disposed at a Class I Landfill. Confirmation soil samples were collected from the excavated area, and the analytical results were below risk-based action levels for VOCs.

4.1.4 Non-Stormwater Discharges (G.VI.A.5)

There are several types of non-stormwater discharges presently produced at the Site:

- Routine maintenance of fire suppression systems and domestic water distribution systems;
- Landscape and irrigation;
- Routine dust suppression;
- Periodic safety shower maintenance checks;
- Treated groundwater from the GETS (Outfall 019).

Site-wide: Fire System Testing

A monthly test is conducted on the fire prevention systems throughout the Site. Water used during fire system testing is discharged as surface water runoff. Tests are typically less than 500 gallons per day (gpd) and evaporate before reaching a NPDES monitoring location.

Treated Groundwater

Treated groundwater is discharged continuously from the GETS (Outfall 019). Approximately 15 gpm (21,600 gpd) is currently discharged by the treatment system. This quantity is expected to increase to 100 gpm (144,000 gpd) when an additional thirteen extraction wells are brought online.

4.1.5 Recent Potential Soil Erosion & Dust Generation Areas (G.VI.A.6)

Figure 8 identifies the location of those areas that have the potential for soil erosion and dust generation. These areas are described below.

Northern Drainage

On November 6, 2007 the Los Angeles Regional Water Quality Control Board (RWQCB) issued Boeing a Cleanup and Abatement Order No. R4-2007-0054 (CAO) (RWQCB 2007) to remove and abate debris in the Outfall 009 drainage (Northern Drainage). The following is a summary of the source removal activities that have been completed as part of this removal action.

The (Liquid Oxygen Rocket Fuel) LOX debris area removal program was implemented in Fall 2007, and was conducted to remove debris and soil containing antimony and asbestos-containing material (ACM). Approximately 2,500 cubic yards (CY) of debris and soil were excavated and transported offsite for disposal. Following removal, substantial erosion control and channel stabilization features were installed in areas where excavation took place. These included coco matting across bare soils, placement of fiber rolls at frequent intervals across bare slopes, placement of hay bales, hydroseed on the stream banks and hillsides of the excavation area, and check dam structures at locations where water velocities would be potentially high.

The Northern Drainage lead and clay target debris removal associated with the former shooting range resumed in June 2009, and additional soil removal was conducted in May 2010. A total of eleven CY of soil was removed bringing the total amount of soil removed from the Northern Drainage to approximately 10,500 CY. Sediment and erosion control BMPs consisting of fiber rolls, straw bales, silt fencing, and rip-rap have been installed in the Northern Drainage watershed downstream of the excavation areas to minimize the potential for erosion along the drainage. These measures will be implemented throughout the duration of the project. Hydroseeding of the areas associated with the Northern Drainage cleanup effort was completed prior to the 2009-2010 rainy season. In May 2010, approximately 1,200 native plants were planted in several topographic lows within and adjacent to the Outfall 009 drainage. Also, in December 2010, three acres of hydroseed was applied in the Northern Drainage and the Former Shooting Range Location. In May 2011, Boeing started removing accumulated sediment within culverts discharging into the Northern Drainage. Most of the work is primarily being conducted in Area I, with some overlap into Area II. Flow from this area is to the west and is monitored at Outfall 009.

Boeing and NASA have worked with the Santa Susana Site Surface Water Expert Panel (Expert Panel) to develop a site-specific Restoration, Mitigation, and Monitoring Plan (RMMP) for the areas of the Northern Drainage that were subject to this Order. The RMMP was submitted to the RWQCB on October 5, 2011 and provides a detailed summary and conceptual designs for restoration and stabilization of the banks and bottom of the Northern Drainage, as well as mitigation and monitoring for riparian plants removed during remediation.

The RMMP implementation is divided into two phases. Phase I includes the installation of structural measures and phase II consists of the installation of plants and bioengineering features. Phase I began on August 28, 2012 and was completed on September 21, 2012. Phase II will commence in the beginning of November 2012 and is expected to be completed before the end of the month.

Interim Soil Removal Activities (ISRA)

The RWQCB issued a CAO to Boeing on December 3, 2008 (RWQCB, 2008). Per the CAO, Interim Soil Removal Activities (ISRA) activities were conducted within Outfall 008 and Outfall 009 watersheds under oversight of the RWQCB. These activities included the identification of soils containing constituents that exceeded NPDES permit limits or benchmarks limits. Approximately 44 areas were identified within the Outfall 008/009 watersheds as shown on Figure 8. Soil removal activities at these areas began in 2009 and are scheduled to continue through 2013.

A project specific SWPPP (MWH, 2009, 2010, and 2011) was submitted for ISRA identifying the BMPs to be implemented during and following soil removal activities. Erosion and sediment control BMPs, including a detention basin in the B-1 area, were installed prior to the start of remedial activities and BMP inspections were performed throughout construction activities; per the requirements of the ISRA project specific SWPPP. These measures will be performed throughout the duration of the project. In addition, hydroseeding and natural BMPs (plants and plant materials) were started in November 2009 to prevent soil erosion in the Outfall 008 and/or 009 watersheds.

Additionally, a BMP Plan for the Outfalls 008 and 009 watersheds was submitted in October 2010 to the RWQCB. The purpose of this plan is to identify and describe stormwater controls for the Outfall 008 and 009 watersheds, to improve stormwater quality and minimize future NPDES exceedances at these outfalls (RWQCB, 2010).

Surface water samples are collected during the rainy season within the Outfalls 008 and 009 watersheds to provide data for the ISRA performance monitoring and potential BMP monitoring programs. The 2011/2012 rainy season represents the third year of ISRA performance monitoring and the second year of BMP monitoring. A summary of the ISRA performance monitoring and potential BMP monitoring data from the 2011/2012 rainy season is presented in the 2011/2012 Rainy Season ISRA Performance Monitoring and Potential BMP Subarea Monitoring Report for the Outfall 008 and 009 Watersheds (Rainy Season report) submitted in August 2012, which included conceptual BMP recommendations provided by the Expert Panel.

Following submittal of the yearly Rainy Season report, the Expert Panel prepares the annual addendum to the BMP Plan. These addendums provides additional detail on the BMP recommendations presented in the Rainy Season reports that will be considered by Boeing and NASA for implementation in the following year and the implementation schedule. Two BMP Plan Addendums have been submitted to the RWQCB, including September 2011 and September 2012 BMP recommendations and the implementation schedule and construction activities are on-going and scheduled to be completed by 2014.

Lower Lot BMP

In the BMP Plan Outfalls 008 and 009 Watersheds (MWH, Surface Water Expert Panel, Geosyntec, Haley & Aldrich, and CH2MHill, December 2010), the panel proposed a treatment BMP (Lower Lot BMP) consisting of a sediment basin, a biofilter and a sump pump to be located within the Lower Parking Lot at SSFL. The purpose of the Lower Lot BMP is to improve NPDES compliance at Outfall 009. The lower lot BMP is designed with a runoff collection cistern at the low point of the parking lot at the Boeing-Sage Ranch property boundary, with a pump that will pump water up to a nearby sediment basin and biofilter area. The stormwater will be treated in the sediment basin and drain via an outlet control structure into a biofilter for discharge of treated stormwater effluent into the northern drainage west of the biofilter site. The construction of the Lower Lot BMP was started in August of 2012 and is anticipated to be completed before the end of the year.

Culvert Modifications

Culvert maintenance activities were completed in April 2009 at eleven culverts feeding into the Northern Drainage on both Sage Ranch and Boeing property. These culvert modifications resulted in reduced water velocities and sediment loadings from eleven side drainages into the Outfall 009 primary drainage. This was accomplished by installing customized headwalls with a filter chamber in existing culverts and lining those culverts. The headwalls have weirs that slow water velocities and create an upstream detention basin in which settling occurs. The overflow passes through a filter box that removes additional pollutants. The culverts were also lined to reduce erosion of older culvert material and discharges of pollutants from the culverts themselves. Fiber rolls and hydroseed were also installed to stabilize soil in the areas disturbed by culvert maintenance activities. Flow from these areas is to the west and is monitored at Outfall 009.

Area IV Soil Borrow Area

The Area IV Soil Borrow Area is currently inactive; however, it may be reactivated for future use. The Area IV Soil Borrow Area has been identified as an on-site area from where clean soil can be obtained and used as fill material in those areas requiring backfill material. BMPs currently include the use of silt fencing, straw bales, seeding, and fiber rolls to limit the potential transport of sediment to surface waters. Stormwater runoff will flow to the south and is monitored at Outfall 002

Demolition Activities

Various inactive facilities have been and continue to be demolished as part of the Santa Susana Site closure. In areas where soil has been disturbed due to demolition activities, sediment and erosion control BMPs are implemented, and consistently evaluated for effectiveness. When necessary, individual construction site SWPPPs have been prepared and implemented on-site for areas greater than one acre. All documentation, inspections and certifications of these SWPPPs are maintained on site. The individual SWPPPs will remain open until a uniform vegetative coverage with 70 percent coverage has been established, or equivalent stabilization measures have been employed.

SECTION 5.0 ASSESSMENT OF POTENTIAL POLLUTION SOURCES (G.VII)

There are a variety of activities at the Site that may contribute to stormwater and non-stormwater discharges, as described in Section 3.0. These are described generally below.

5.1 POTENTIAL SOURCES OF POLLUTANTS

5.1.1 Active Areas

Due to the closure of rocket test operations, the current onsite activities are primarily related to site closure activities. The active areas of the Site that comprise of remediation systems, BMP construction or sites currently undergoing demolition may have equipment, materials, and chemicals stored that have the potential to come in contact with stormwater. Areas of the Site that are undergoing physical and/or chemical remediation may also be a potential source of pollution since these areas have been identified as having impacted soil.

5.1.2 Inactive and Non Operational Areas

Non-operational areas may be a potential source of pollution since buildings, materials, unused equipment, tanks, and process equipment are still present in these areas and they have the potential to come in contact with stormwater. Inactive areas that have undergone demolition but have not undergone remediation or corrective action may be a potential source of pollution from stormwater coming into contact with impacted soil.

5.1.3 Permitted Non-Stormwater Discharges

Permitted non-stormwater discharges occurring at the Santa Susana Site, includes treated groundwater effluent from the GETS, and monthly tests on the fire prevention systems throughout the Site. Treated groundwater is discharged at Outfall 019 as described previously in this document. Water used during fire system testing is discharged as surface water runoff. Tests are typically less than 500 gallons per day and evaporate before reaching a NPDES monitoring location.

5.2 POLLUTANTS WITH POTENTIAL TO BE PRESENT

The list of significant materials stored and used at the various operational areas of the Santa Susana Site is included as Appendix B. Some of these significant materials are potential pollutant sources; however, with proper implementation of BMPs, they are not likely to impact stormwater quality. Potential pollutants may have included petroleum hydrocarbon-based compounds such as RP-1 fuel and hydraulic oils; polychlorinated biphenyls (PCBs), dioxins, polyaromatic hydrocarbons (PAHs); metals such as lead and mercury; and chlorinated hydrocarbon-based solvents such as TCE. Potential sources

of these pollutants may be naturally occurring and/or man-made. Petroleum hydrocarbon-based compounds were typically used for rocket engine testing, mechanical equipment use and maintenance, and fueling operations. Metals, dioxins, and PAHs may be naturally occurring in the soil, bedrock and sediment at the Site, as well as from lead-based paint, parts machining, equipment fabrication, and manufacturing operations. Past operations such as equipment and parts cleaning and engine test stand cleaning are also potential sources of solvent pollutants.

Stormwater monitoring is being conducted in accordance with the NPDES Permit. Stormwater monitoring has been documented in quarterly and annual reports issued to the RWQCB in accordance with the permit requirements. The constituents monitored are to assure that potential pollutants have not impacted stormwater quality leaving the Site, and include conventional pollutants, toxic priority pollutants, and unconventional pollutants. Existing data on the quality of stormwater for the specific constituents under the three categories of pollutants are summarized in the quarterly and annual reports submitted to the RWQCB. Copies of the reports are also maintained online at www.boeing.com/aboutus/environment/santa_susana/programs.html and at the Santa Susana Site.

SECTION 6.0 STORMWATER MANAGEMENT AND CONTROLS

Stormwater management control practices involve proper understanding and implementation of BMPs. Site BMPs that reduce the introduction of pollutants into stormwater are discussed below. In addition, a Best Management Practices Plan (BMPP) was prepared for the Site to outline specific BMPs that address the control of potential pollutant release in non-stormwater releases. The BMPP includes those BMP measures installed at each Outfall location. The BMPP is included as Appendix B.

6.1 BMPs

There are various types of BMPs: administrative, non-structural, and structural controls. Administrative BMPs are those developed and executed within a Site's management structure. Non-structural BMPs are those procedures or practices used by Site management and operating personnel to reduce the potential for stormwater contamination. Structural BMPs are physical constructions or devices used to reduce the potential for stormwater contamination. Descriptions of the structural and non-structural BMPs that have been implemented at the regulated outfalls are included in Appendix B. Descriptions of SWTSS optimization at specific outfalls are provided in Section 3.5 of this SWPPP, with further details available in Appendix B. A description of various BMPs that may be implemented at the Site, as identified in fact sheets from the California Stormwater Quality Association (CASQA) California Stormwater BMP Handbook - Industrial and Commercial that may be implemented at the Site are included in Appendix D.

6.2 BMP IMPLEMENTATION (G.VIII)

The Site has implemented many BMPs to improve control of potential pollutants from entering the stormwater system. Existing structural BMPs have been implemented at the Site, and new BMPs are implemented consistently at the Site. All BMP's are inspected and maintained on a routine basis to ensure effectiveness.

Good Housekeeping and Preventive Maintenance (G.VIII.A.1 and G.VIII.A.2)

Site buildings are inspected to ensure proper housekeeping practices, other BMP implementation, and ensure equipment and storage areas are properly maintained.

Spill Contingency Plan and Accidental Discharges Contingency Plan (G.VIII.A.3)

The Site maintains a Spill Contingency Plan which was prepared as part of the Site's Spill Prevention and Response Plan. This plan identifies petroleum product drum and tank storage areas and quantities. It also outlines standard material handling and management practices, spill containment, spill response clean-up procedures, and emergency contact information. The Site's Spill Prevention and Response Plan (including Spill Contingency Plan) and Accidental Discharges Contingency Plan are included as Appendix E.

Waste Handling and Storage (G.VIII.A.4)

Waste handling procedures are specific to individual operations at the Santa Susana Site. Emergency spill procedures are identified in the SPCC.

Hazardous substances are stored in containers which meet Department of Transportation (DOT) regulations or other appropriate regulations with labels affixed to each container that identifies the contents and date of accumulation. Appropriate containment berms and spill pallets are in place for stored containers to minimize the potential for an accidental release. Proper emergency spill and safety response procedures are in place, as outlined in the Site's Spill Prevention and Response Plan and Accidental Discharges Contingency Plan (Appendix E). Proper personal safety measures and environmental protection are used when handling all chemicals and hazardous wastes.

Employee Training (G.VIII.A.5)

The Santa Susana Site conducts training sessions every three years, in addition to periodic tailgate safety meetings to ensure adequate understanding of stormwater pollution prevention by key personnel. In addition to the Boeing team identified, additional trained individuals from various departments and/or contractors may be utilized to conduct inspections and implement portions of the SWPPP. Any new personnel supporting the program will be provided the initial training and subsequently receive the refresher training as noted above.

Waste Handling / Waste Recycling (G.VIII.A.6)

Non-hazardous waste is contained in various roll-off bins or other approved containers throughout the Site, and is picked up on a regular basis by a contracted waste disposal company.

Hazardous wastes are stored in containers that have affixed labels that appropriately identify the contents and date of accumulation. Several satellite areas are located throughout the Site, which protect the containers from coming into contact with stormwater during temporary storage of waste. The 90-day Hazardous Waste Storage Yard (located in Area I), the NASA Hazardous Waste Storage Yard (located in Area II), and the DOE Hazardous Waste Storage Yard (located in Area IV) provides a storage area for hazardous wastes prior to the waste being transported off Site for disposal or recycling.

Record Keeping and Internal Reporting (G.VIII.A.7)

SWPPP records are maintained at a centralized location at the facility. Internal reporting procedures consist of routine status meetings which may consist of weekly, bi-weekly or monthly meetings based on site conditions.

Records of all monitoring information, copies of all the NPDES monitoring reports, and records of all data used to complete the reports will be retained for a period of five years from the date of measurement, report, or monitoring activity. All records that are not already at the RWQCB office will be provided to the RWQCB upon request.

Erosion Control and Site Stabilization (G.VIII.A.8)

A large portion of the Site is undeveloped land that contains natural vegetation. In areas where native soils and vegetation are disturbed and access is feasible, erosion control measures, which may include, but is not limited to, silt fencing, straw bales, plastic sheeting, hydroseeding, soil binders, check dams, fiber rolls, or sandbags, may be used to prevent erosion and potential sediment transport into the stormwater system. Areas where significant erosion control and site stabilization measures have been implemented are shown on Figure 8.

Inspections (G.VIII.A.9 and G.IX.A – G.IX.D)

A comprehensive visual inspection of both non-structural and structural BMPs will be conducted annually in September to inspect areas potentially contributing to pollutants in stormwater runoff and to evaluate whether the BMPs identified in the SWPPP are adequate and are being properly implemented. Also, inspections of non-structural BMPs will be conducted before and after the rainy season (October to April) and once per month during the rainy season to confirm proper implementation and to monitor effectiveness at each active building at the Site. Records of these inspections will include the date of the inspection, name of the individuals who performed the inspection, and the observations made.

Quality Assurance (G.VIII.A.10)

The stormwater program in place at the Site is under the umbrella of an industrial NPDES permit that contains provisions and requirements to ensure quality assurance. The Site monitoring program has a Quality Assurance/ Quality Control procedure in place and the SWPPP consists of an annual review of the training logs and record keeping.

As a means of ensuring compliance with toxicity requirements in the NPDES permit, toxicity monitoring (both acute and chronic) is performed at specific monitoring locations as specified in the NPDES Permit. Toxicity monitoring is conducted, as required, in accordance with the Acute Toxicity Monitoring Program and Chronic Toxicity Monitoring Program, outlined in the Monitoring and Reporting Program Number 6027 (Appendix A). If toxicity results exceed the limitations defined, the initial investigation of the Toxicity Reduction Evaluation (TRE) Workplan prepared for the Site will be implemented. The TRE Workplan outlines actions to investigate and identify the cause of toxicity, actions to mitigate the impact of the discharge and prevent the recurrence of toxicity, and methods.

SECTION 7.0 REFERENCES

Geosyntec Consultants and Santa Susana Field Laboratory Surface Water Expert Panel, 2010. BMP Subarea Sampling Recommendations for 008/009 BMP Work Plan. December 16.

Geosyntec and Surface Water Expert Panel, 2012. Final 2011/2012 Rainy Season ISRA Performance Monitoring and Potential BMP Subarea Monitoring Report for the Outfall 008 and 009 Watersheds (Rainy Season report), August.

Geosyntec and Surface Water Expert Panel, 2011. ISRA BMP Plan Addendum 1, Santa Susana Field Laboratory, Ventura County, California. Geosyntec and Expert Panel, September 30.

Geosyntec and Expert Panel, 2012. ISRA BMP Plan Addendum 2, Santa Susana Field Laboratory, Ventura County, California, September 28.

Haley & Aldrich, Inc. (H&A), 2011. Northern Drainage Restoration,. Mitigation, and Monitoring Plan (RMMP), Santa Susana Field laboratory, Ventura County, California, October.

MWH, 2012. Interim Source Removal Activities (ISRA) Stormwater Pollution Prevention Plan (SWPPP), June 17, 2009, Revision 1 August 10th 2009, Revision 2 June 25th, 2010 and Revision 3 November 11.

FIGURES

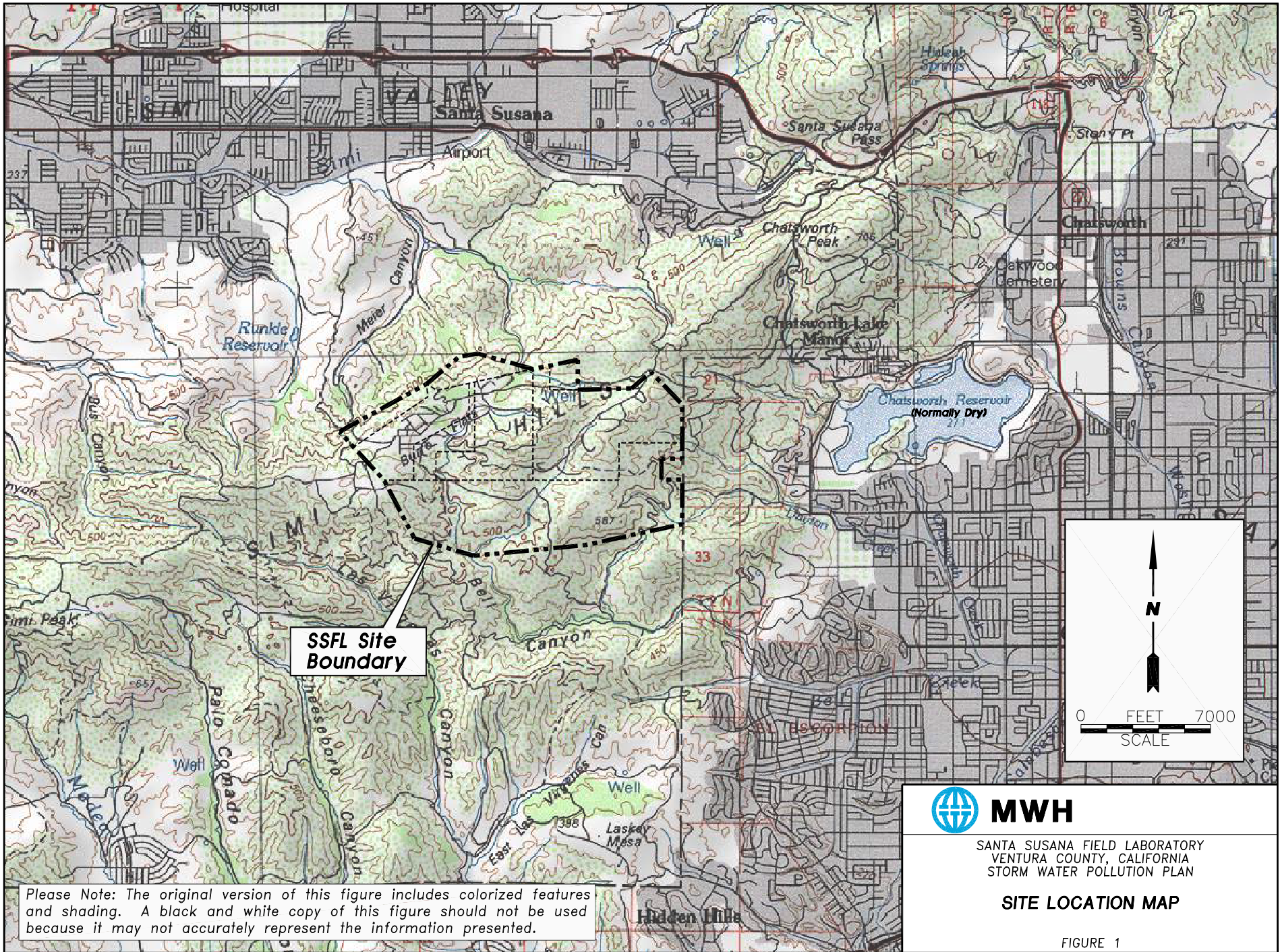

SSFL Site Boundary

Please Note: The original version of this figure includes colored features and shading. A black and white copy of this figure should not be used because it may not accurately represent the information presented.

 **MWH**
 SANTA SUSANA FIELD LABORATORY
 VENTURA COUNTY, CALIFORNIA
 STORM WATER POLLUTION PLAN

SITE LOCATION MAP

FIGURE 1

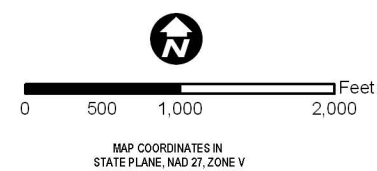
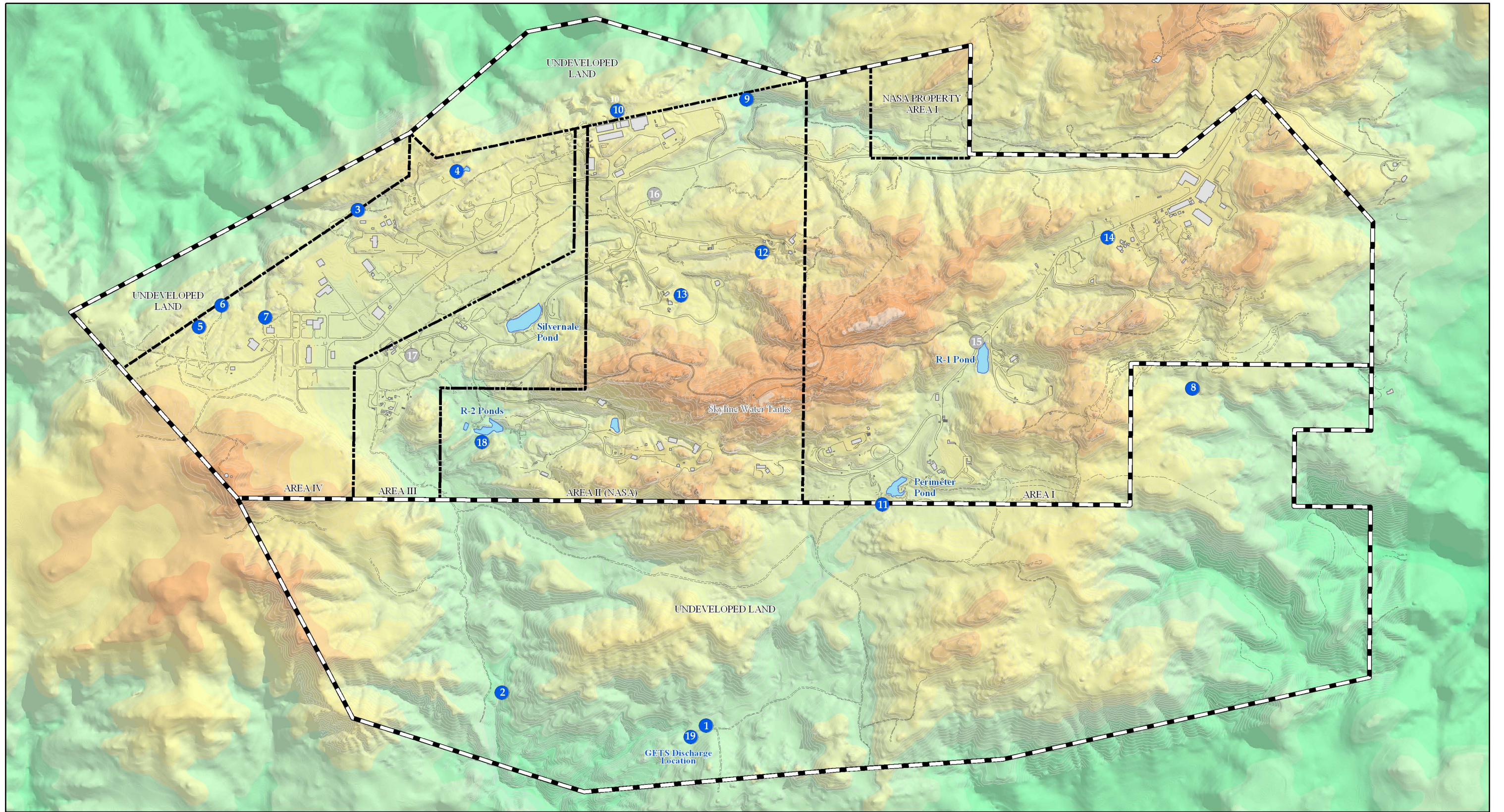

- NPDES Outfalls (RWQCB Primary Oversight Authority)
- Historical NPDES Outfalls
- Surface Water Reclamation Ponds

Elevation Legend		
■	> 2200 ft	■
■	2120 - 2200 ft	■
■	2040 - 2120 ft	■
■	1950 - 2040 ft	■
■	1900 - 1950 ft	■
■	1800 - 1900 ft	■
■	1730 - 1800 ft	■
■	1580 - 1730 ft	■
■	< 1580 ft	■

- | | | | |
|--|------------------------------|--|--------------------------------|
| | SSFL Property Boundary | | Existing Building or Structure |
| | Administrative Area Boundary | | |
| | Ground Elevation Contours | | |
| | A/C Curbing | | |
| | Dirt Road | | |

Site Map

Date: September 17, 2010
 File: \\Uspas1netapp1\dev\rocketdyne\gis\MasterGISFiles\ISRA_Projects\ISRA_MXD\BMP\CompliancePlanSept2010\Fig2_SiteLocationMap.mxd

FIGURE 2

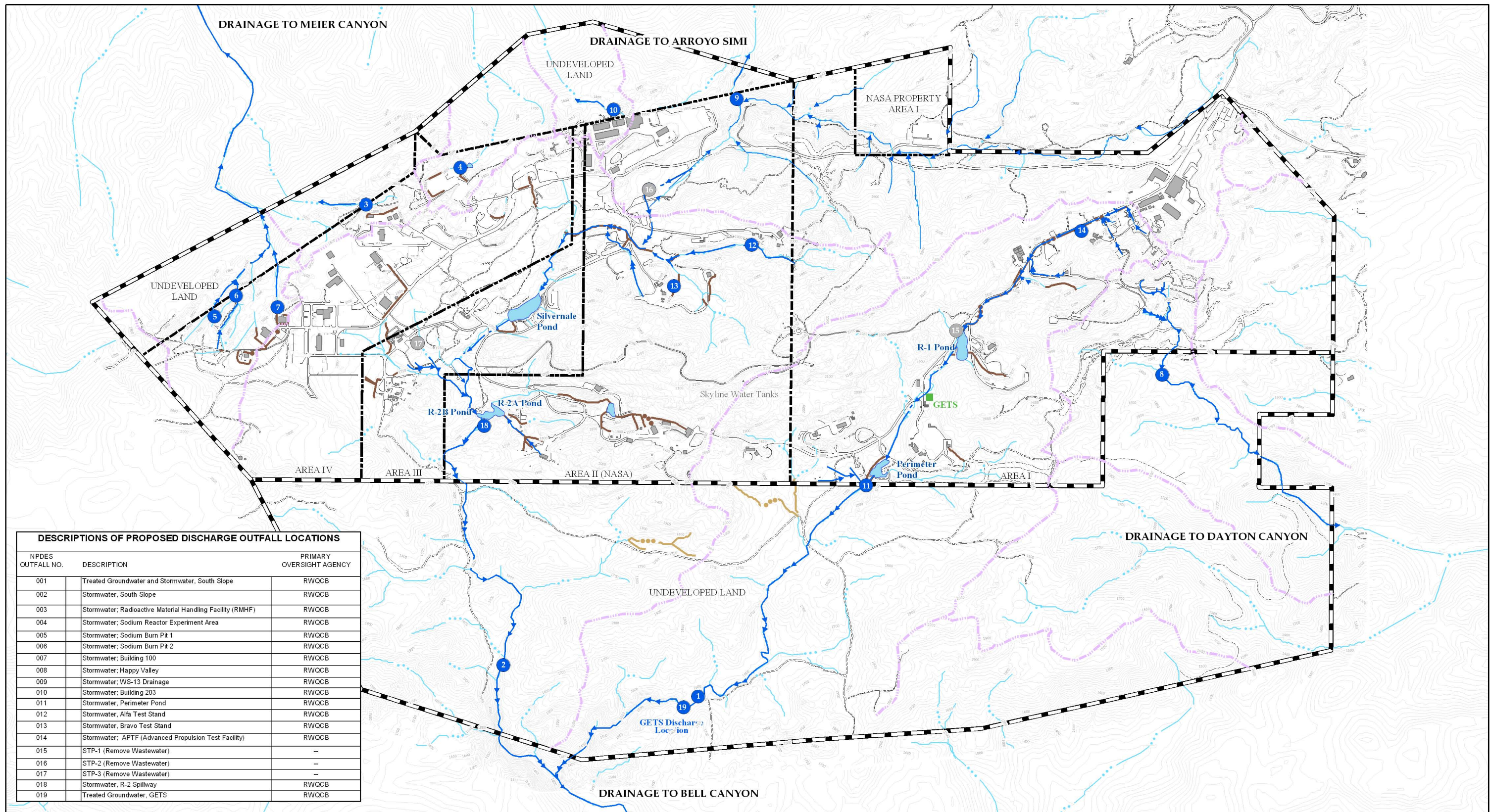

DESCRIPTIONS OF PROPOSED DISCHARGE OUTFALL LOCATIONS

NPDES OUTFALL NO.	DESCRIPTION	PRIMARY OVERSIGHT AGENCY
001	Treated Groundwater and Stormwater, South Slope	RWQCB
002	Stormwater, South Slope	RWQCB
003	Stormwater; Radioactive Material Handling Facility (RMHF)	RWQCB
004	Stormwater; Sodium Reactor Experiment Area	RWQCB
005	Stormwater; Sodium Burn Pit 1	RWQCB
006	Stormwater; Sodium Burn Pit 2	RWQCB
007	Stormwater; Building 100	RWQCB
008	Stormwater; Happy Valley	RWQCB
009	Stormwater; WS-13 Drainage	RWQCB
010	Stormwater; Building 203	RWQCB
011	Stormwater, Perimeter Pond	RWQCB
012	Stormwater, Alfa Test Stand	RWQCB
013	Stormwater, Bravo Test Stand	RWQCB
014	Stormwater; APTF (Advanced Propulsion Test Facility)	RWQCB
015	STP-1 (Remove Wastewater)	--
016	STP-2 (Remove Wastewater)	--
017	STP-3 (Remove Wastewater)	--
018	Stormwater, R-2 Spillway	RWQCB
019	Treated Groundwater, GETS	RWQCB

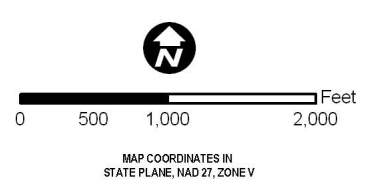

- Legend**
- NPDES Outfalls (RWQCB Primary Oversight Authority)
 - Historical NPDES Outfalls
 - Groundwater Extraction Treatment System (GETS)
 - Effluent Pathways
 - Surface Water Drainage Divide
 - Natural Drainage
 - Concrete Lined Drainage
 - Graded Drainage
 - Surface Water Reclamation Ponds

- Base Map Legend**
- SSFL Property Boundary
 - Administrative Area Boundary
 - Ground Elevation Contours
 - Drainage Pathways
 - A/C Curbing
 - Dirt Road
 - Existing Building or Structure

Site Map with Storm Water Drainage Systems and Outfalls

Date: September 17, 2010
 File: \\usps\inetapp1\del\rocketdyne_gis\MasterGISFiles\ISRA_Projects\ISRA_MXD\BMP\CompliancePlan\Sept2010\Fig1-2_SiteMapOf_Drainages.mxd

FIGURE 3

FILE: CAD\MUEBKE\BOENG_SANTA_SUSANA\SWPPP\SWPPP_FIGS_10_10_12

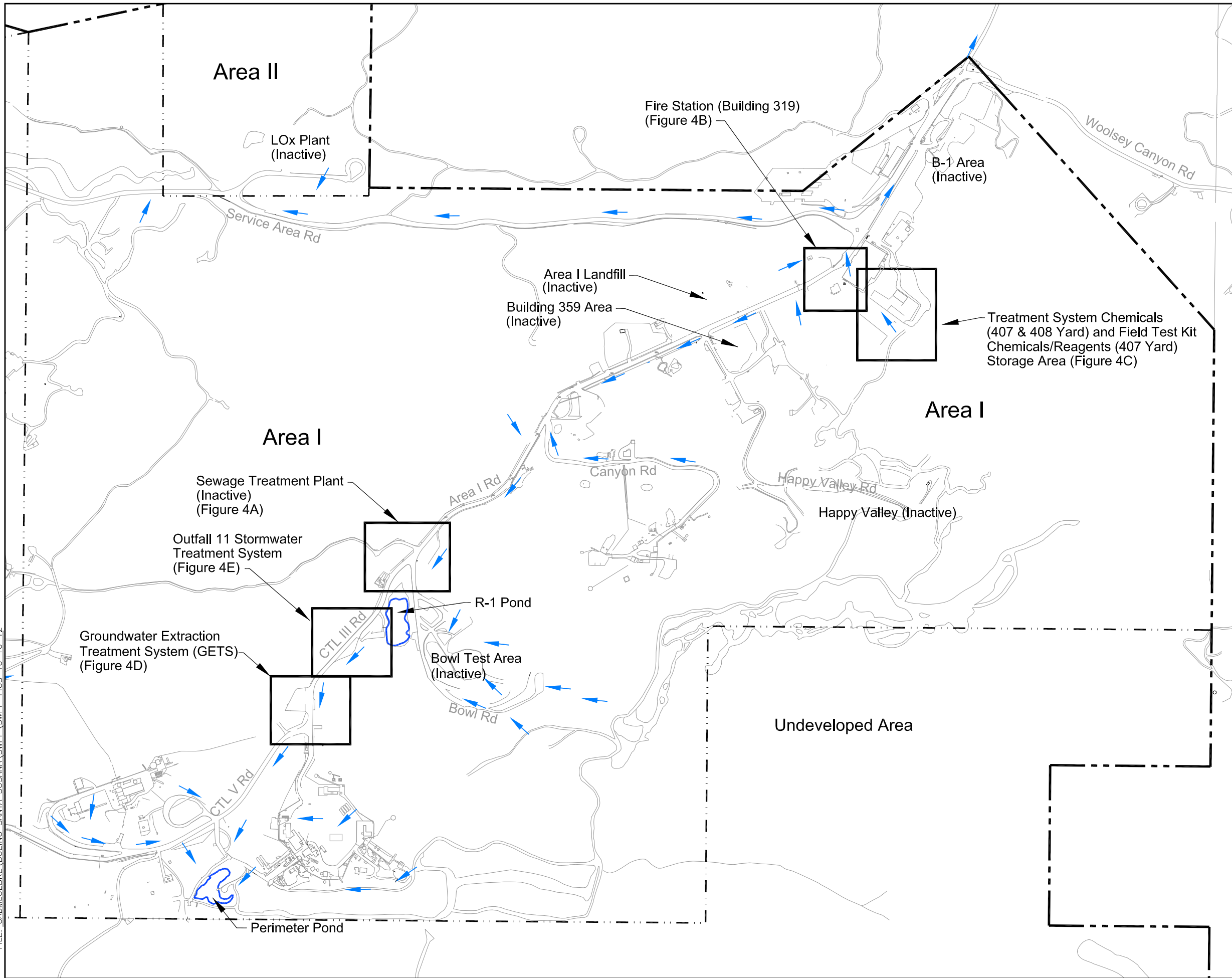

- Legend**
- Property Boundary
 - Administrative Boundary
 - Building
 - Surface Water Flow Direction
 - Dirt Road

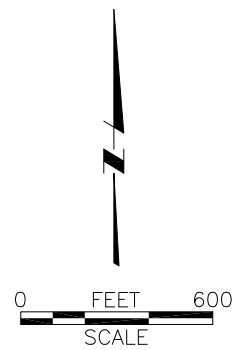

MWH
 SANTA SUSANA FIELD LABORATORY
 VENTURA COUNTY, CALIFORNIA
 STORMWATER POLLUTION PLAN



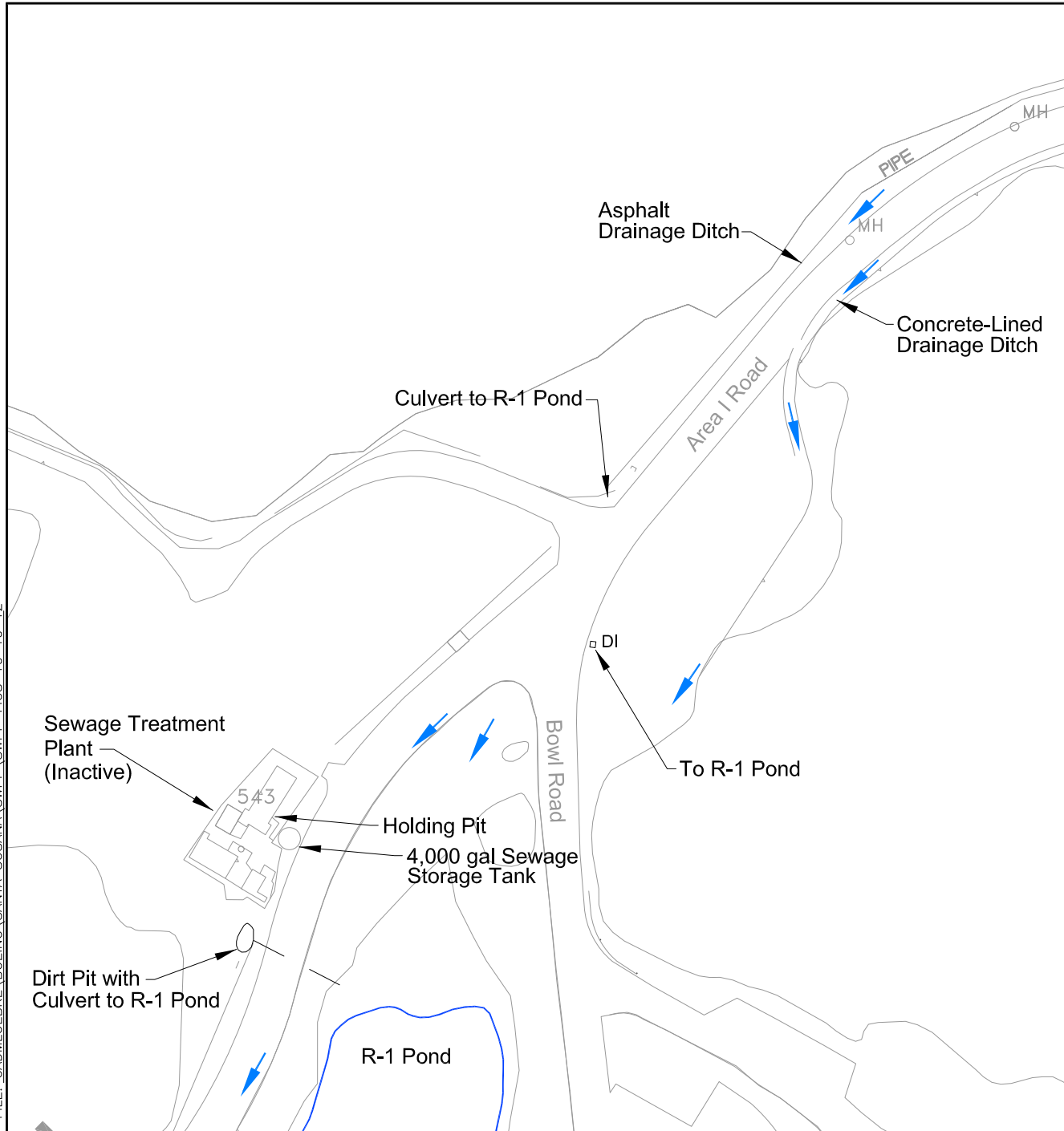

**AREA I
 KEY MAP**

FIGURE 4

FILE: _CAD\MUEBKE\BOEING\SANTA_SUSANA_SWPPP_SWPPP_FIGS_10_10_12

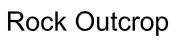

Legend

-  Building
-  MH Manhole
-  DI Drain Inlet
-  Rock Outcrop
-  Dirt Road
-  Surface Water Flow Direction

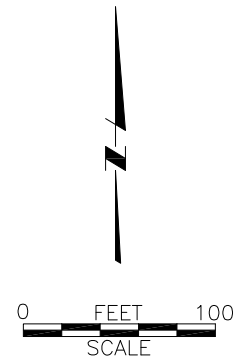

SANTA SUSANA FIELD LABORATORY
 VENTURA COUNTY, CALIFORNIA
 STORMWATER POLLUTION PLAN



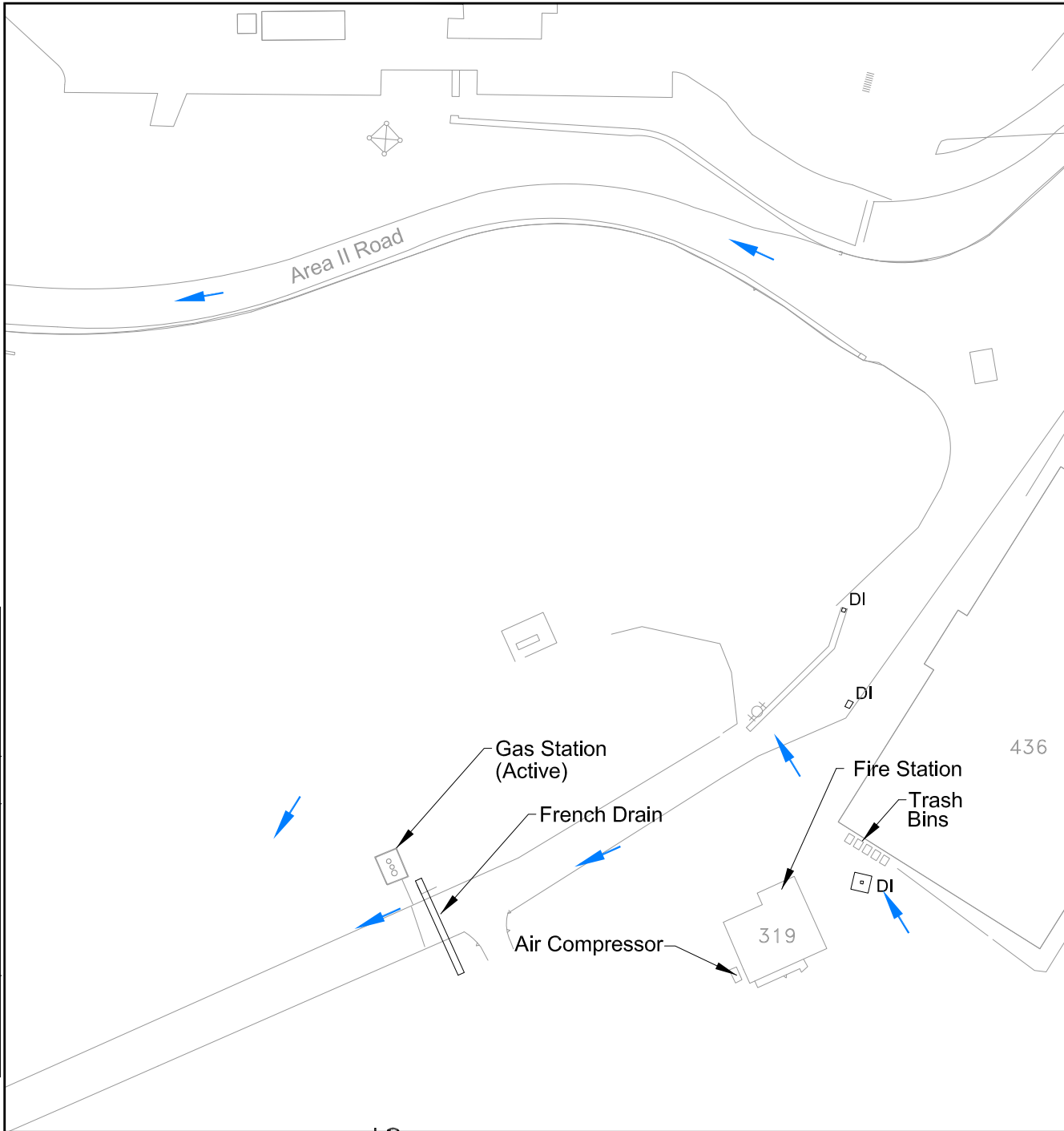

**AREA I - SEWAGE TREATMENT
 PLANT (INACTIVE)**

FIGURE 4A

FILE: CAD\M\LUEBKE\BOEING_SANTA_SUSANA\SWPP\SWPP_FIGS_10_10_12



Legend

-  Building
-  Rock Outcrop
-  Fire Hydrant
-  DI
-  Surface Water Flow Direction



MWH

SANTA SUSANA FIELD LABORATORY
VENTURA COUNTY, CALIFORNIA
STORMWATER POLLUTION PLAN



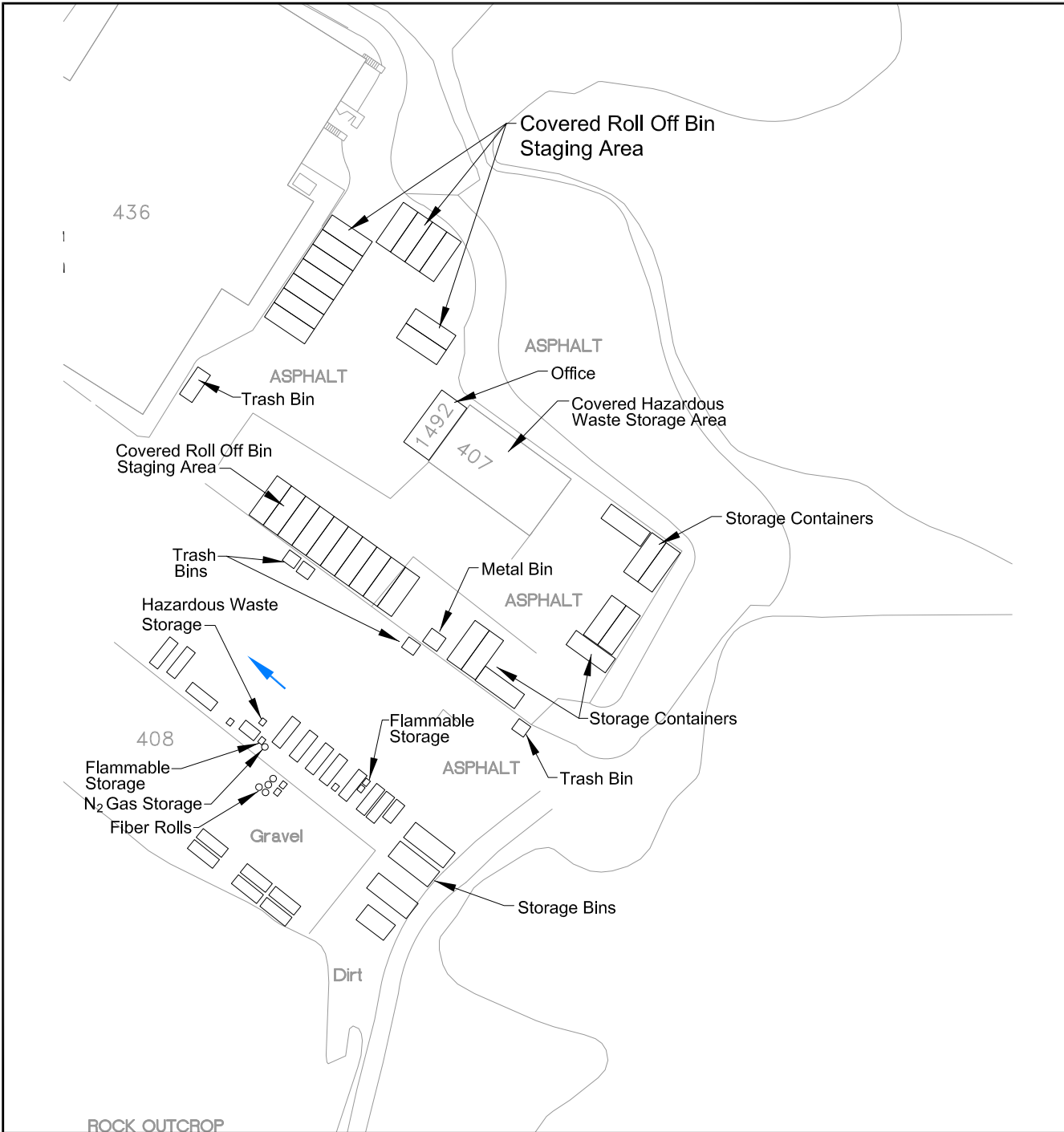

AREA I - FIRE STATION
(BUILDING 319)

FIGURE 4B

FILE: _CAD\M\L\EBKE\BOEING\SANTA SUSANA SWPP\SWPP_FIGS_10_10_12



Legend

-  Building
-  Rock Outcrop
-  Dirt Road
-  Surface Water Flow Direction

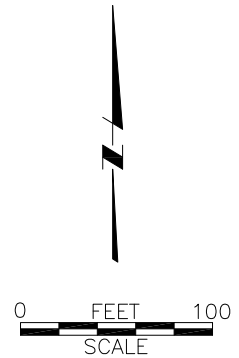

SANTA SUSANA FIELD LABORATORY
 VENTURA COUNTY, CALIFORNIA
 STORMWATER POLLUTION PLAN



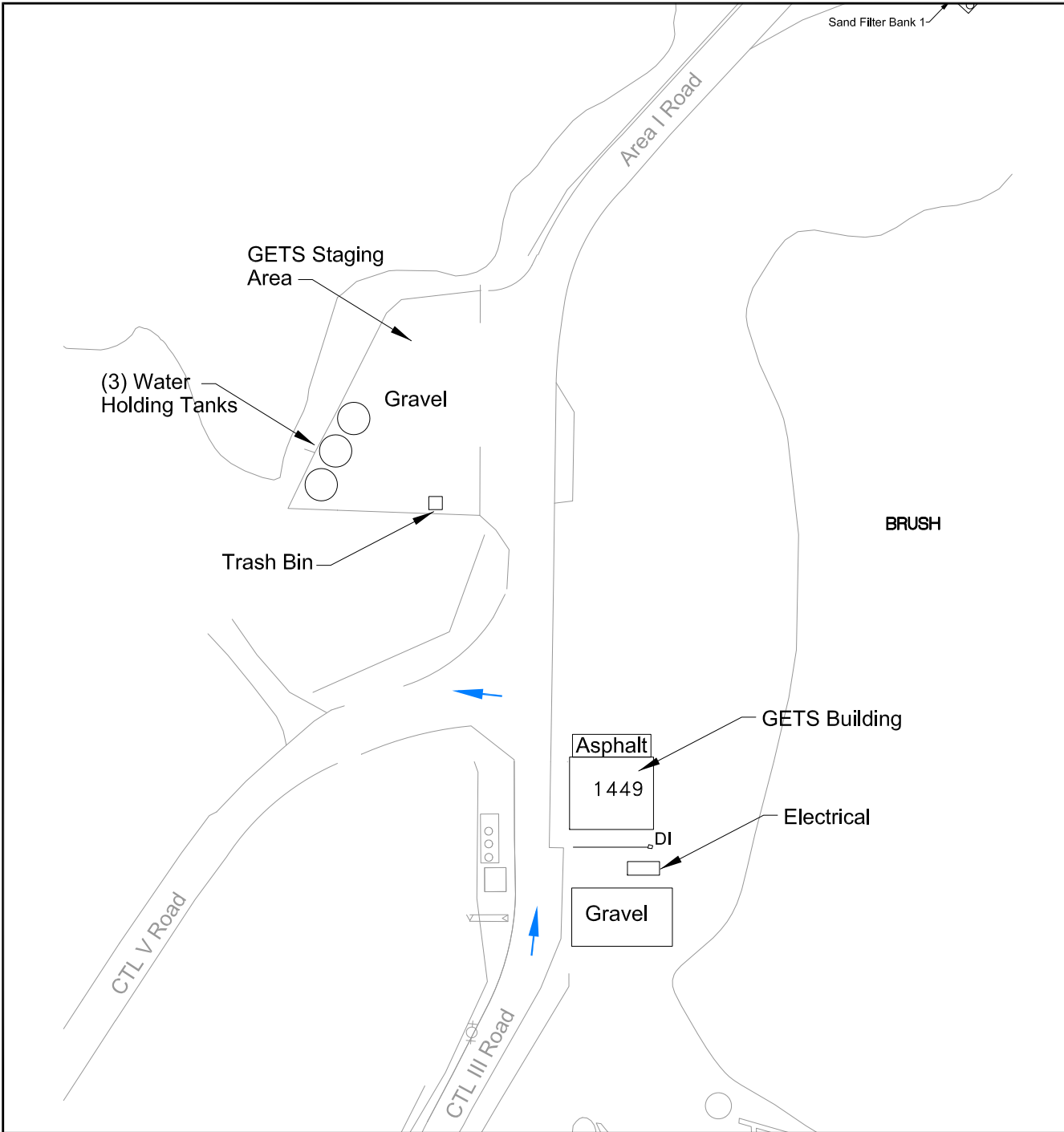

TREATMENT SYSTEM CHEMICALS (407 & 408 YARD) & FIELD TEST KIT CHEMICALS/ REAGENTS (407 YARD) STORAGE AREA

FIGURE 4C

ROCK OUTCROP



Legend

-  Building
-  Rock Outcrop
-  Dirt Road
-  Surface Water Flow Direction
-  DI

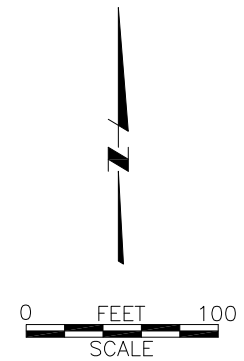

SANTA SUSANA FIELD LABORATORY
VENTURA COUNTY, CALIFORNIA
STORMWATER POLLUTION PLAN

GROUNDWATER EXTRACTION
TREATMENT SYSTEM (GETS)

FIGURE 4D

FILE: _CAD\MUEBEKE\BOEING\ SANTA SUSANA SWPP\ SWPP_FIGS_10_10_12

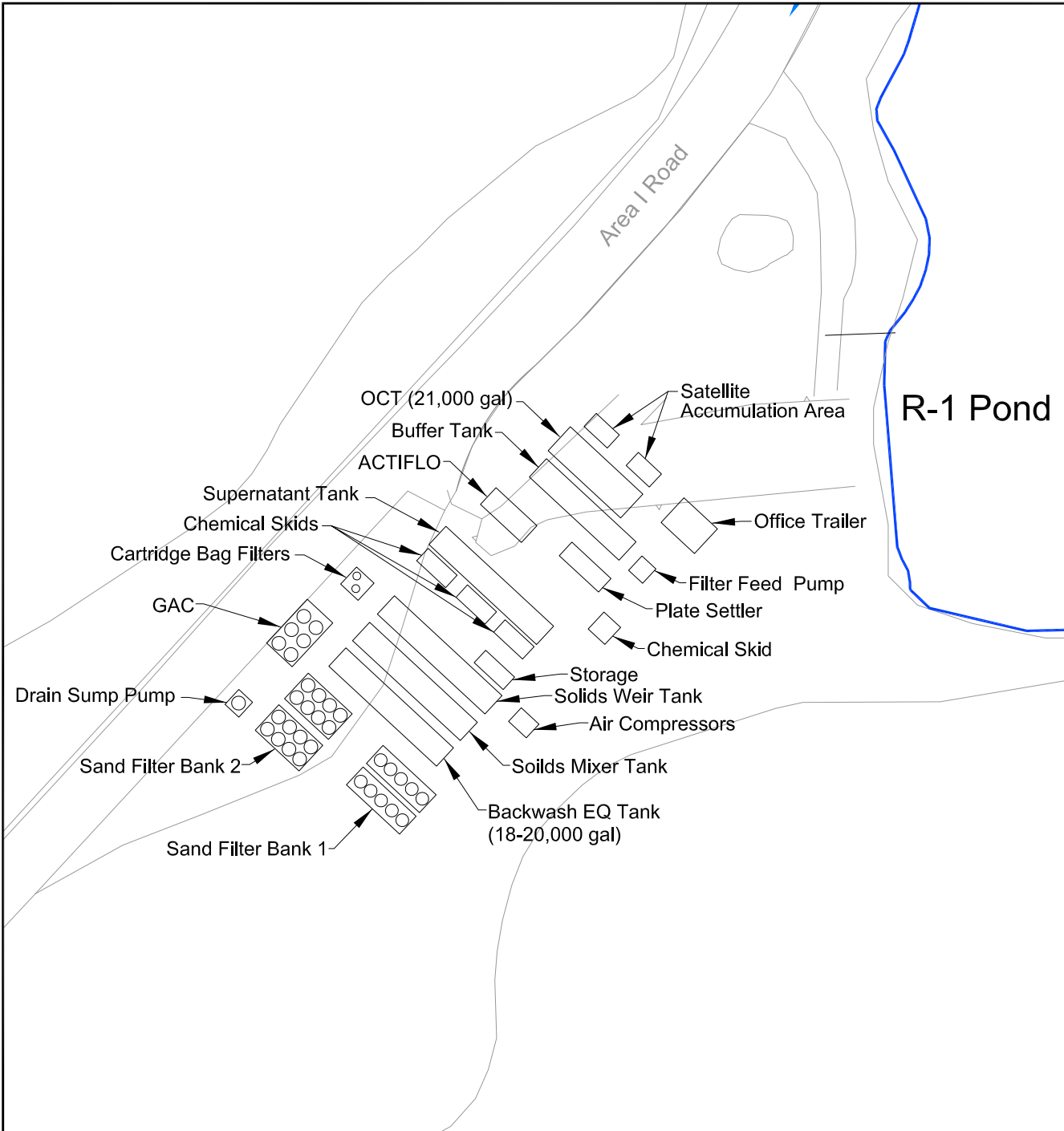

Legend

- Building
- Rock Outcrop
- Dirt Road
- Surface Water Flow Direction

R-1 Pond

Area I Road

Scale: 0 FEET 60 SCALE

North Arrow

MWH

SANTA SUSANA FIELD LABORATORY
 VENTURA COUNTY, CALIFORNIA
 STORMWATER POLLUTION PLAN

**OUTFALL 011
 STORMWATER TREATMENT SYSTEM**

FIGURE 4E

Laser Lab (Building 203) and Expendable Launch Vehicle (Bldg 206) (Figure 5F)

Undeveloped Area

Area II

- Legend**
- Property Boundary
 - Administrative Boundary
 - Building
 - Surface Water Flow Direction
 - Dirt Road
 - Kerosene

Area II Landfill (Inactive)

Building 515 Sewage Treatment Plant (Inactive)

Fire Station (Inactive)

ALFA-BRAVO Fuel Farm (Inactive) (Figure 5C)

Storage Propellant Area (SPA) (Figure 5E) (Inactive)

Area IV

NASA Area II Hazardous Waste Yard (Figure 5H)

Previous Spill Investigation (RP-1 Fuel)

ALFA Test Stand (Inactive) (Figure 5A)

Area I

Area II

BRAVO Test Stand (Inactive) (Figure 5B)

Area III

Coca Delta Fuel Farm (Inactive)

Water Tanks

Area II

Coca Pond

Rocket Nozzle Test Facility (RNTF) Coca Area (Inactive)(Figure 5G)

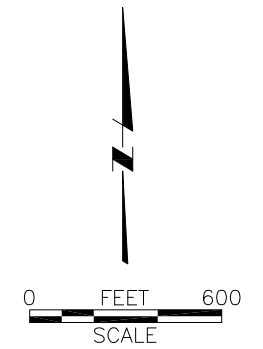

MWH

SANTA SUSANA FIELD LABORATORY
VENTURA COUNTY, CALIFORNIA
STORMWATER POLLUTION PLAN

AREA II
KEY MAP

FIGURE 5

FILE: CAD\MUEBEK\BOEING_SANTA_SUSANA\SWPPP\SWPPP_FIGS_10_10_12

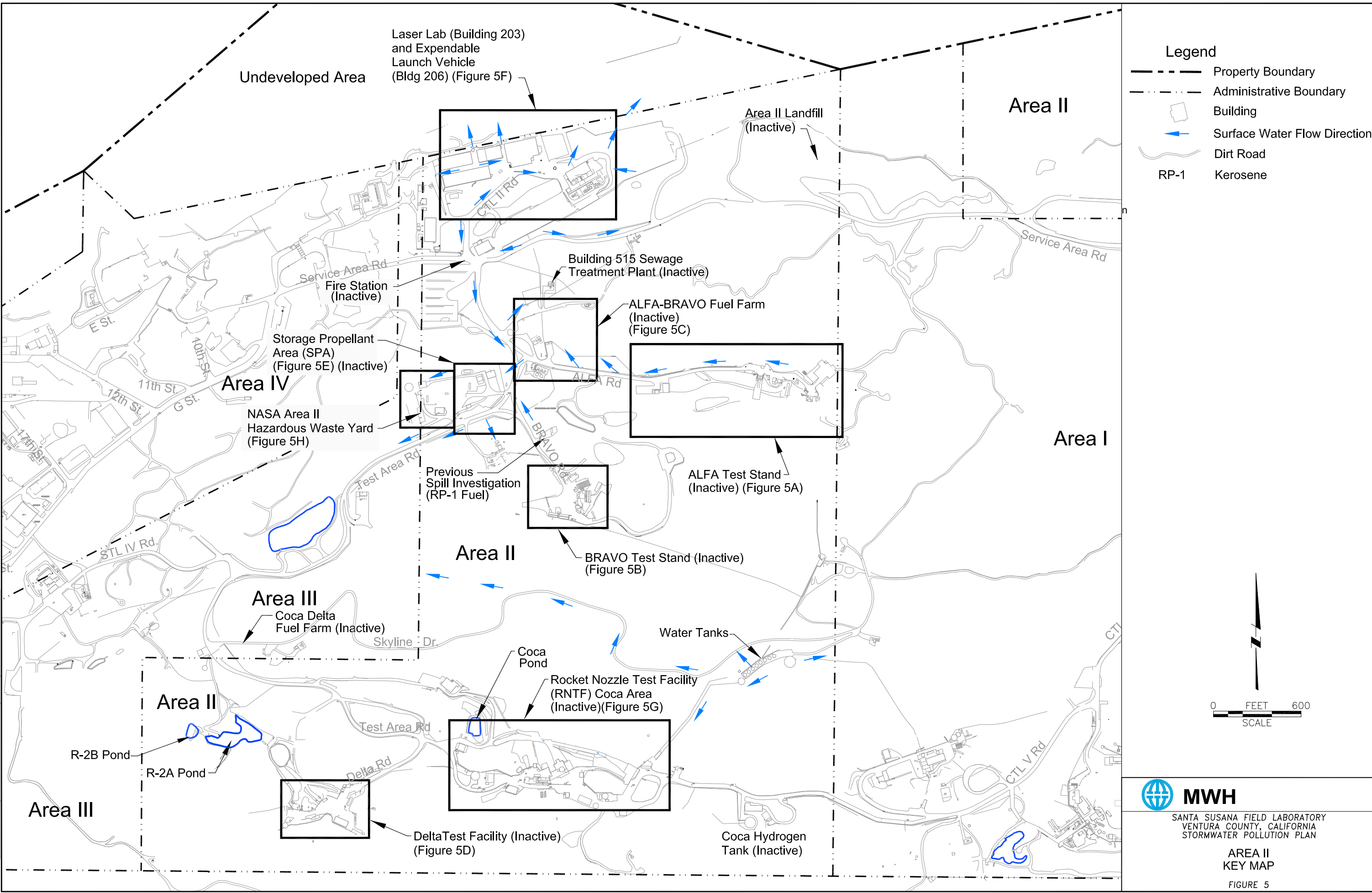

FILE No. CADMLUEBKE\SANTA_SUSANA\SWPP\SWPP_FIGS_10_10_12

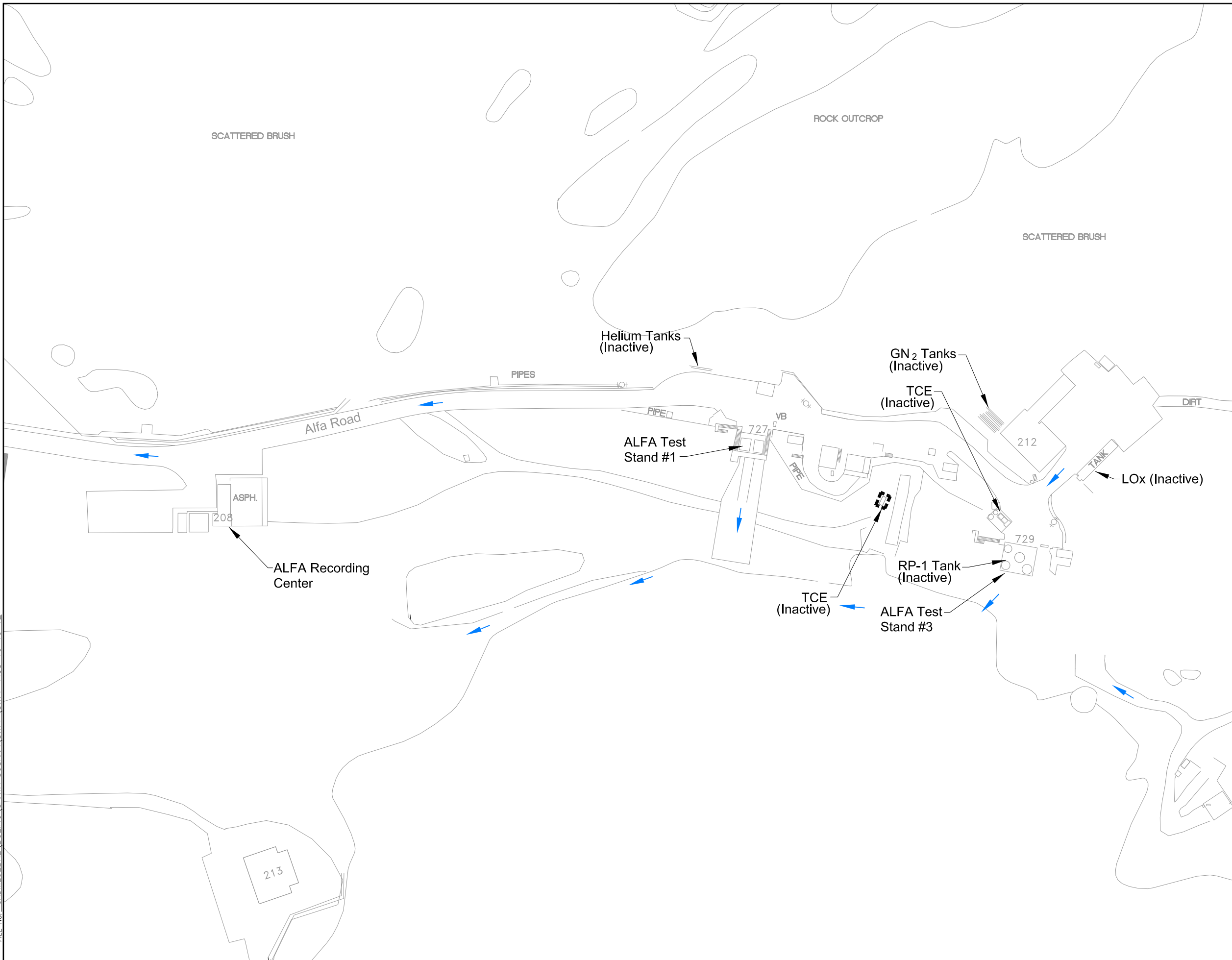

- Legend**
- Concrete Containment Berm
 - Rock Outcrop
 - Dirt Road
 - Fire Hydrant
 - Valve Box
 - Surface Water Flow Direction
 - LOx Liquid Oxygen
 - GN₂ Gaseous Nitrogen
 - RP-1 Kerosene
 - TCE Trichloroethene

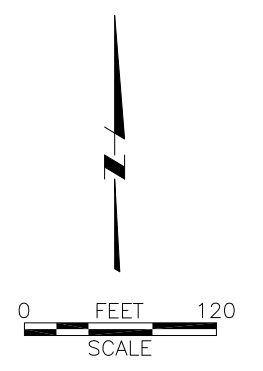



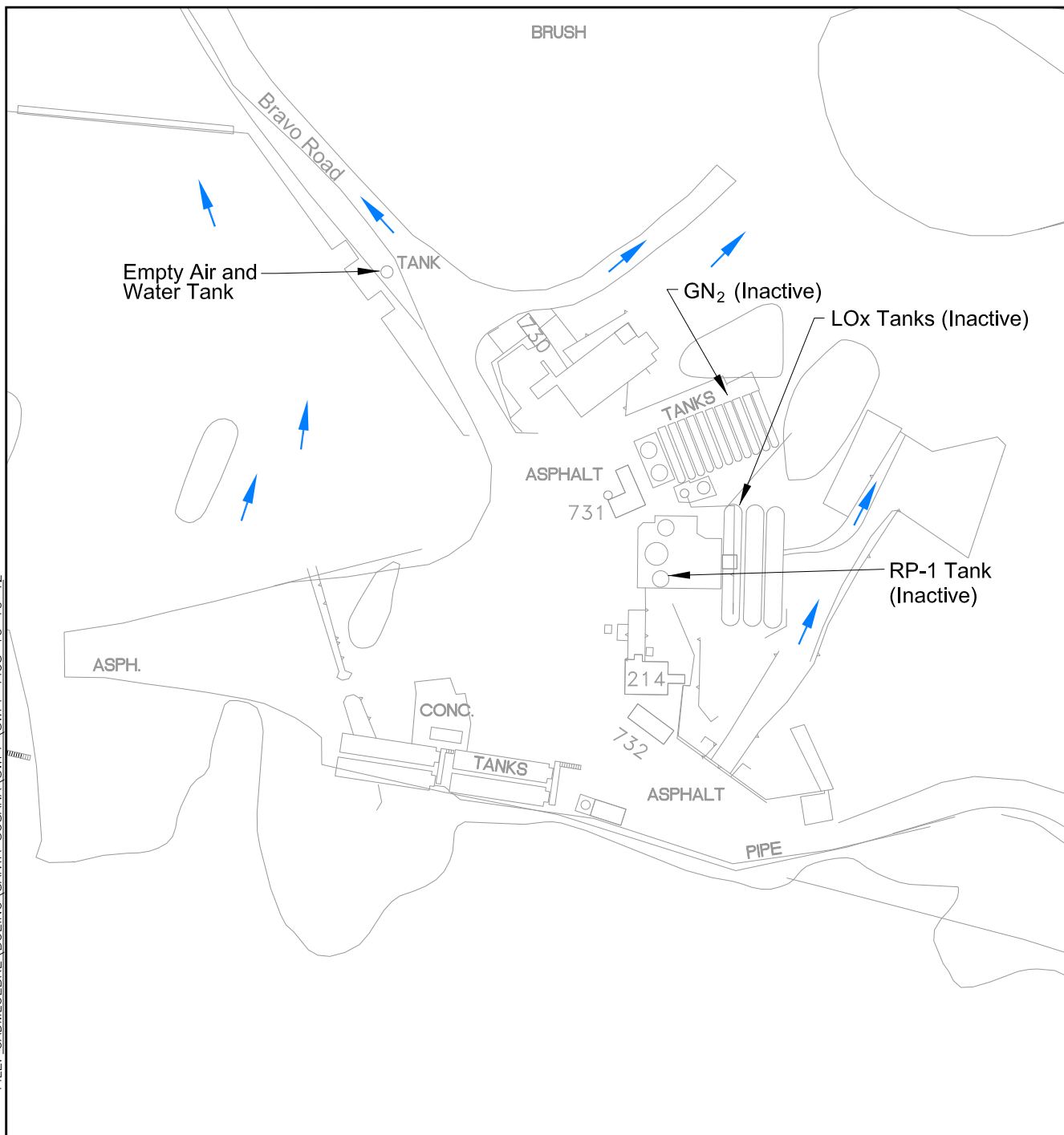

MWH
 SANTA SUSANA FIELD LABORATORY
 VENTURA COUNTY, CALIFORNIA
 STORMWATER POLLUTION PLAN
AREA II - ALFA TEST STAND (INACTIVE)
 FIGURE 5A

FILE: CAD\M\LUEBKE\BOEING\SANTA_SUSANA_SWPP\SWPP_FIGS.10.10.12



Legend

-  Building
-  Rock Outcrop
-  Dirt Road
-  Surface Water Flow Direction
- LOx** Liquid Oxygen
- GN₂** Gaseous Nitrogen
- RP-1** Kerosene



MWH

SANTA SUSANA FIELD LABORATORY
VENTURA COUNTY, CALIFORNIA
STORMWATER POLLUTION PLAN

AREA II - BRAVO TEST STAND
(INACTIVE)

FIGURE 5B

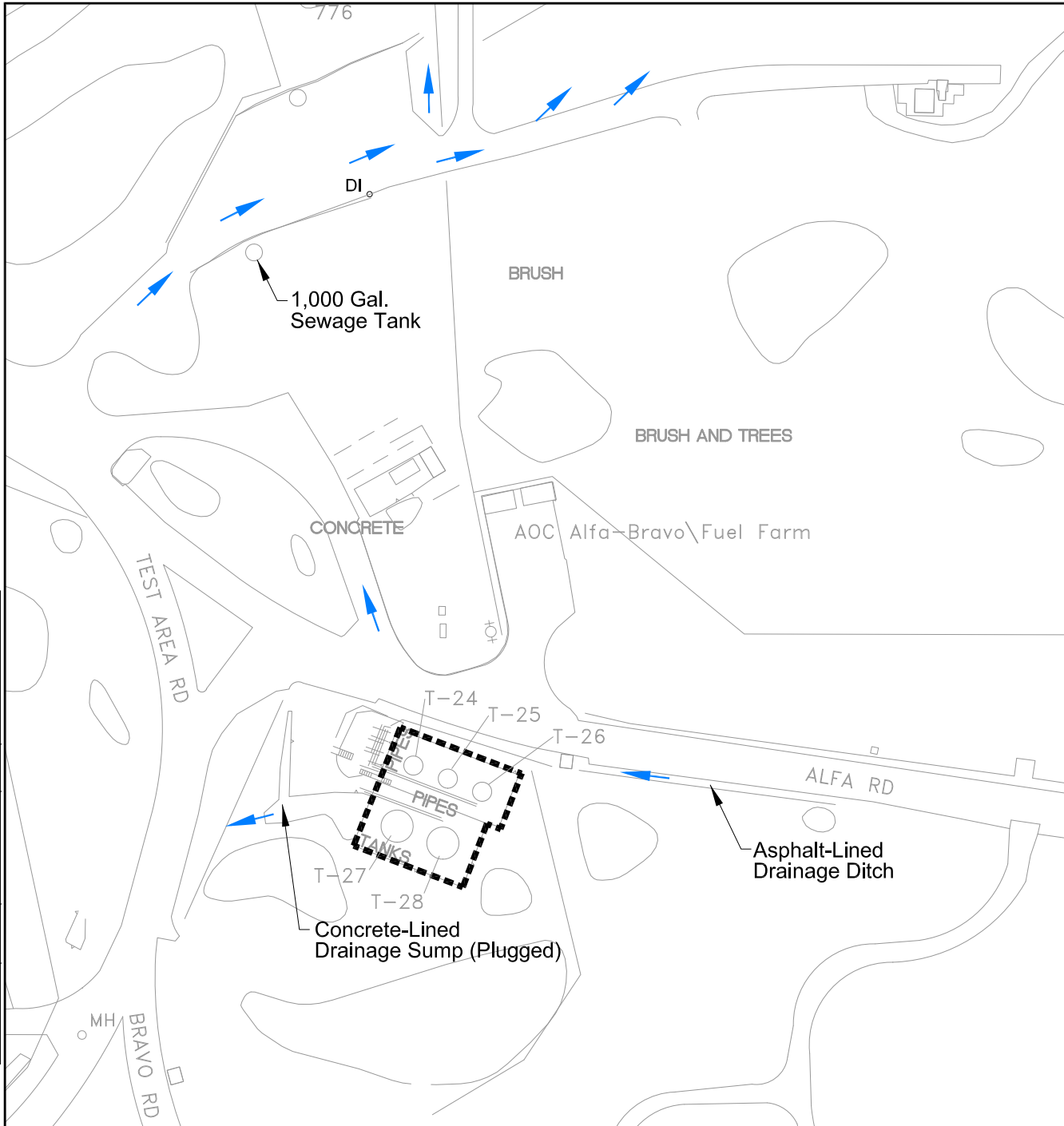

- Legend**
- Concrete Containment Berm
 - Building
 - Manhole
 - Rock Outcrop
 - Dirt Road
 - Fire Hydrant
 - Drain Inlet
 - Surface Water Flow Direction

Tank T-24 Inactive
 Tank T-25 Inactive
 Tank T-26 Inactive
 Tank T-27 Inactive
 Tank T-28 Inactive

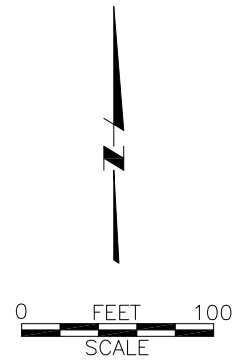

SANTA SUSANA FIELD LABORATORY
 VENTURA COUNTY, CALIFORNIA
 STORMWATER POLLUTION PLAN





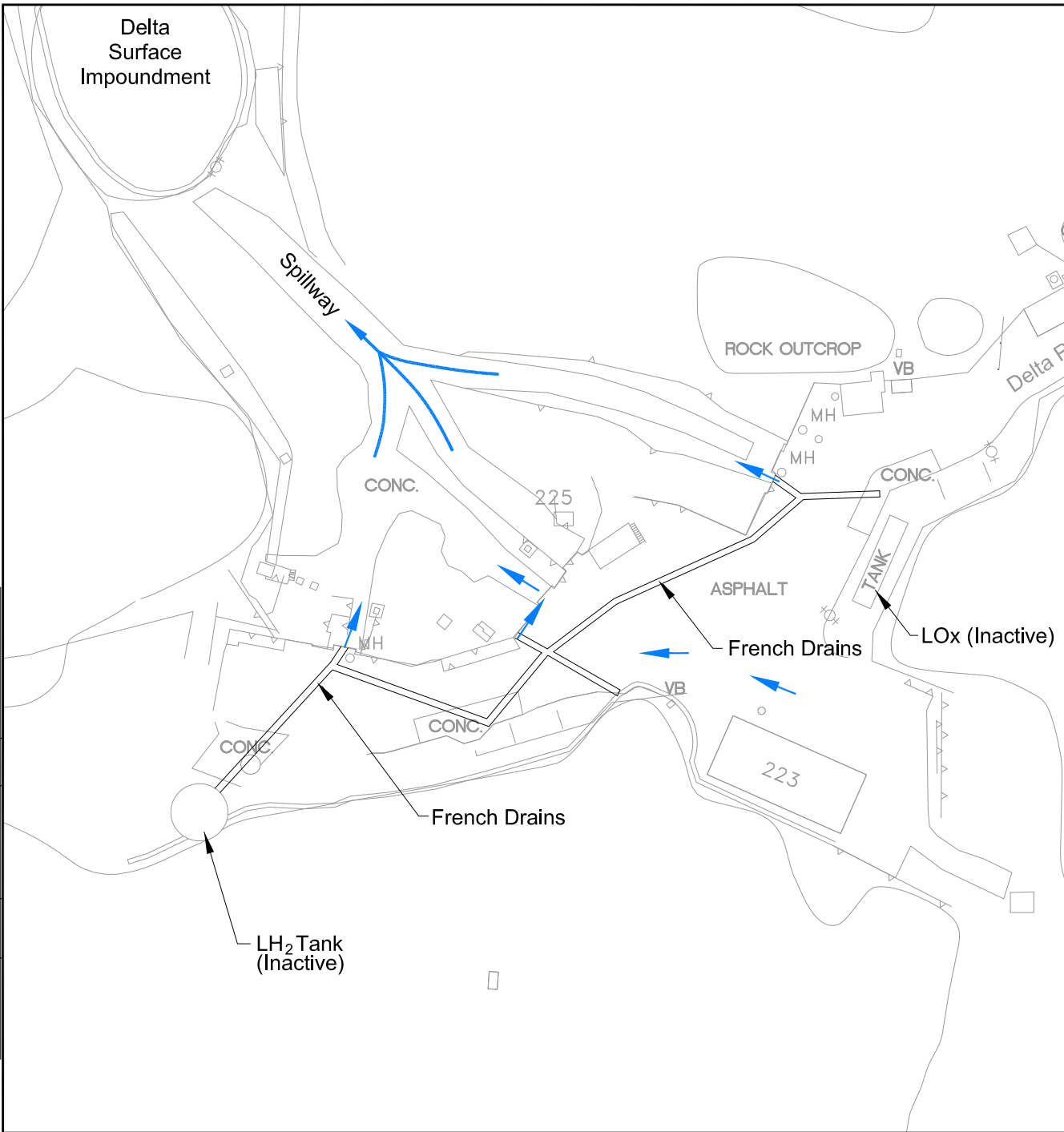

**AREA II - ALFA-BRAVO FUEL FARM
 (INACTIVE)**

FIGURE 5C

FILE: CAD\M\JEBKE\BOEING\SANTA_SUSANA\SWPP\SWPP_FIGS_10_10_12



Legend

-  Building
-  MH Manhole
-  Rock Outcrop
-  Dirt Road
-  Fire Hydrant
-  VB Valve Box
-  Surface Water Flow Direction
- LH₂ Liquid Hydrogen
- LOx Liquid Oxygen

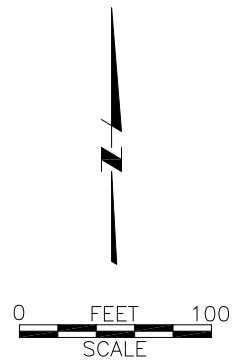

SANTA SUSANA FIELD LABORATORY
VENTURA COUNTY, CALIFORNIA
STORMWATER POLLUTION PLAN



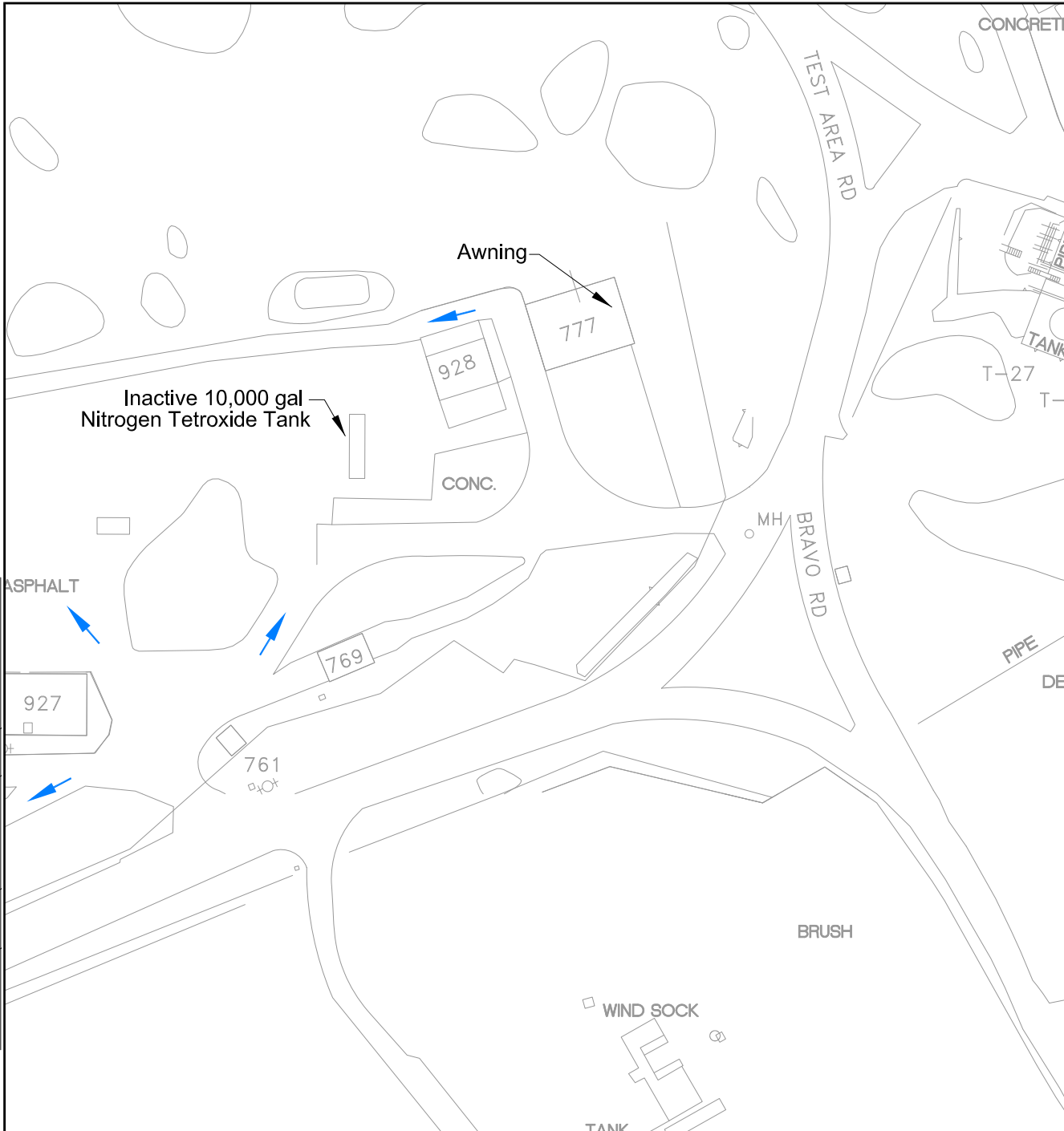

**AREA II - DELTA TEST FACILITY
(INACTIVE)**

FIGURE 5D

FILE: CADMLLEBKE\BOEING\SANTA_SUSANA\SWPP\SWPP_FIGS_10_10_12



Legend

-  Building
-  Rock Outcrop
-  Dirt Road
-  Fire Hydrant
-  Surface Water Flow Direction

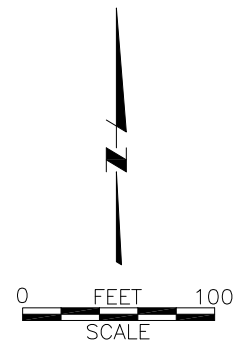





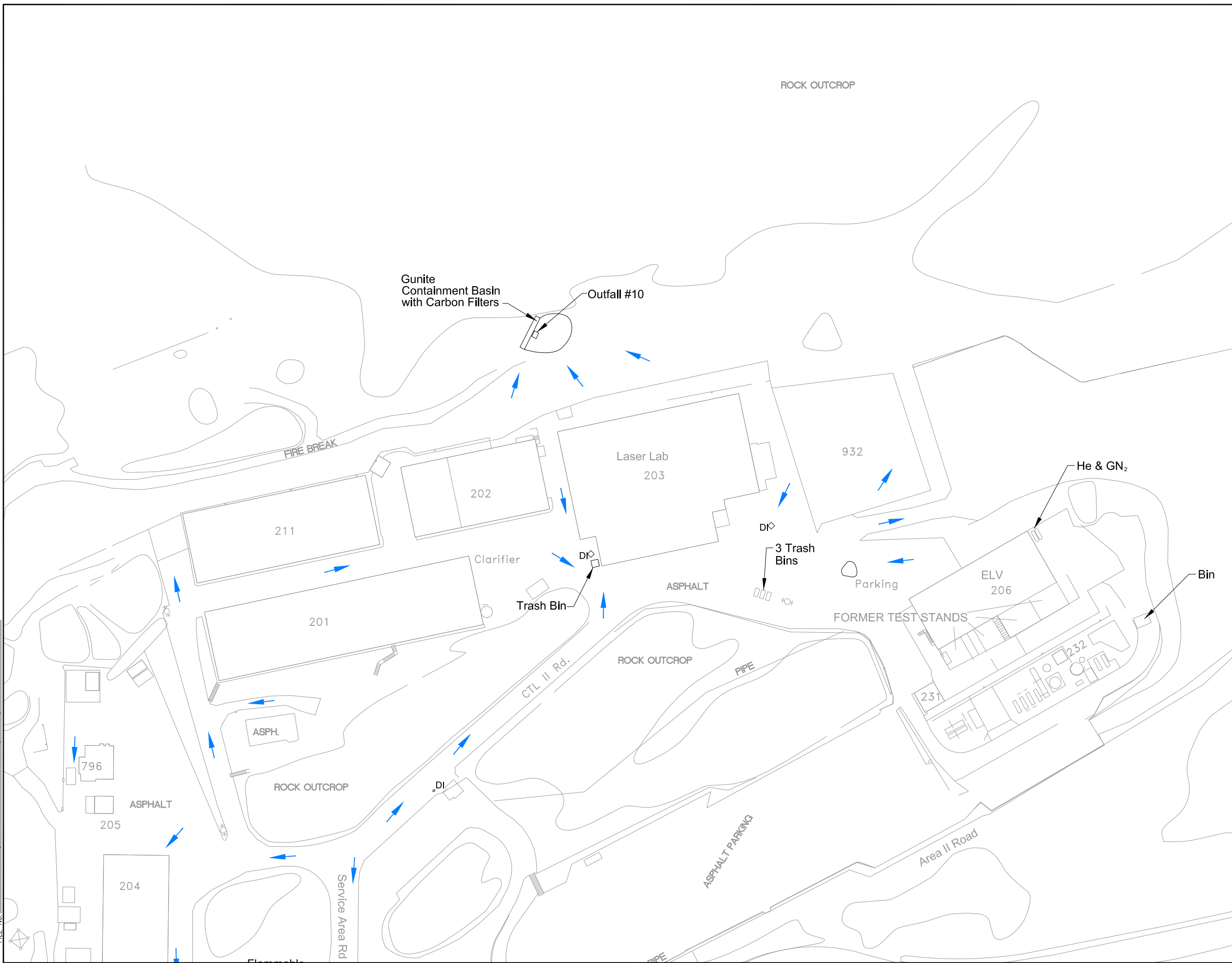

SANTA SUSANA FIELD LABORATORY
 VENTURA COUNTY, CALIFORNIA
 STORMWATER POLLUTION PLAN
**AREA II STORAGE PROPELLANT
 AREA (SPA) (INACTIVE)**

FIGURE 5E

FILE No. CADMLUEBKE\BOEING SANTA SUSANA\SWPP\SWPP FIGS 10 10 12



- Legend**
-  Building
 -  Rock Outcrop
 -  Dirt Road
 -  Fire Hydrant
 -  DI
 -  High Voltage Power Line Tower
 -  Surface Water Flow Direction

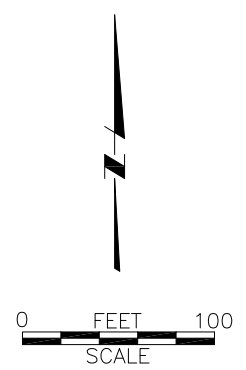

 **MWH**





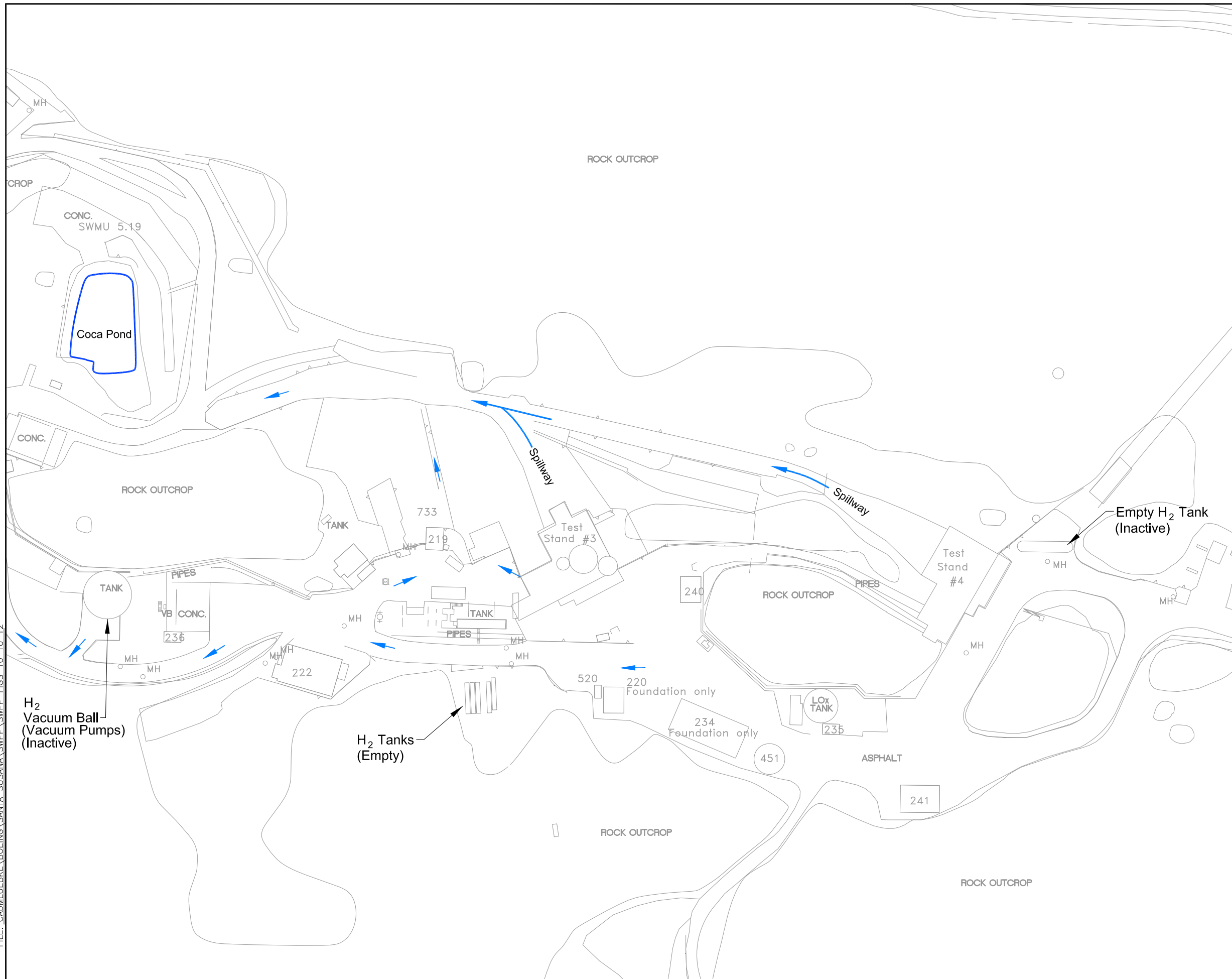

SANTA SUSANA FIELD LABORATORY
 VENTURA COUNTY, CALIFORNIA
 STORMWATER POLLUTION PLAN

**AREA II - LASER LAB (BUILDING 203)
 AND EXPENDABLE LAUNCH VEHICLE (ELV)
 (BUILDING 206)**

FIGURE 5F

FILE: CAD\MUEBKE\BOEING\SANTA SUSANA\SWPP\SWPP_FIGS_10_10_12





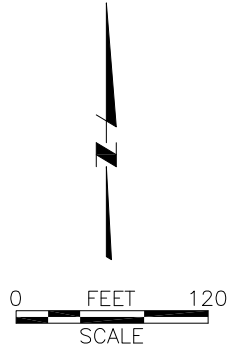



- Legend**
-  Building
 -  MH Manhole
 -  Rock Outcrop
 -  Dirt Road
 -  Fire Hydrant
 -  Surface Water Flow Direction
 - LOx Liquid Oxygen
 - H₂ Hydrogen

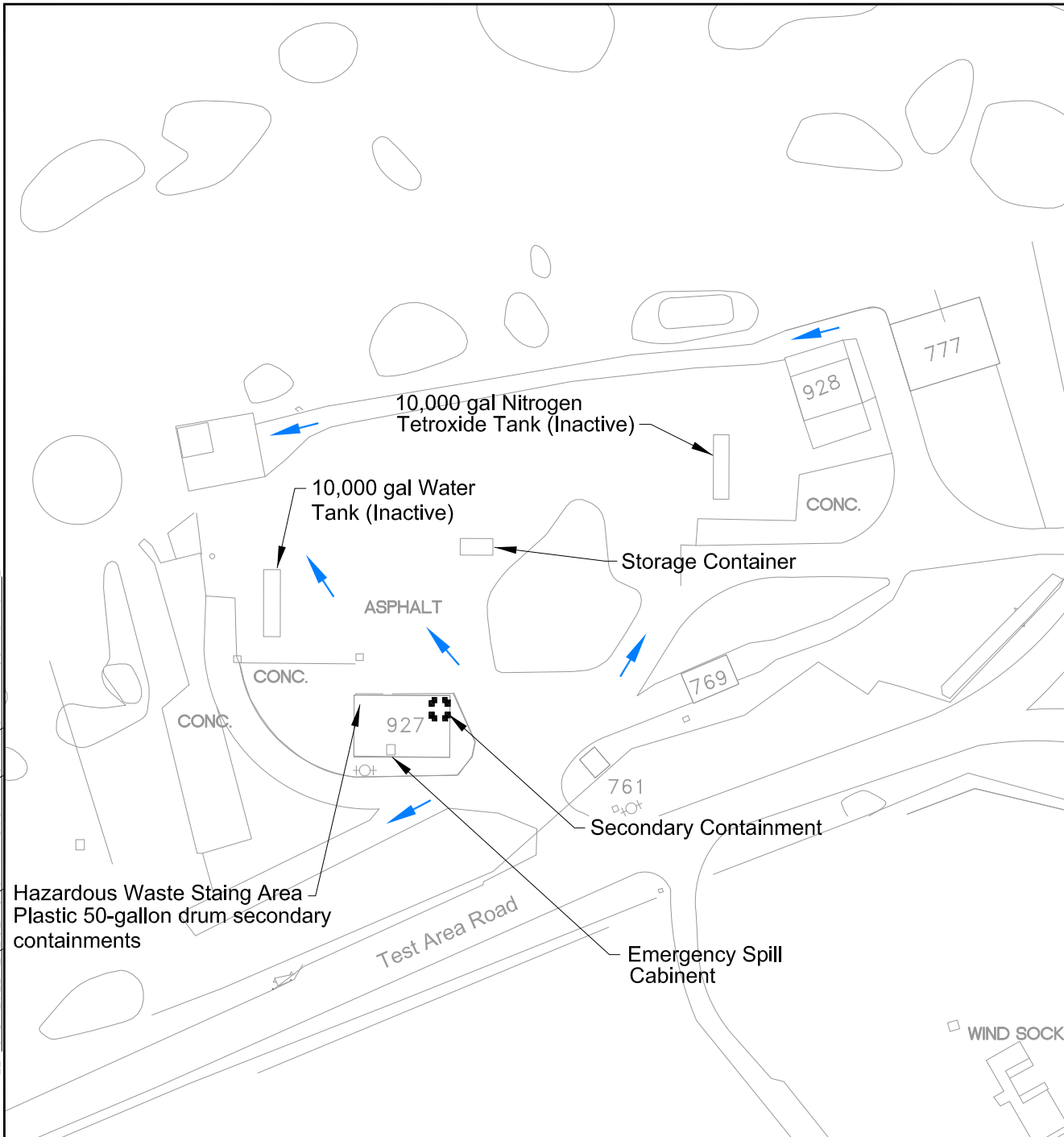

MWH
 SANTA SUSANA FIELD LABORATORY
 VENTURA COUNTY, CALIFORNIA
 STORMWATER POLLUTION PLAN
AREA II - ROCKET NOZZLE TEST FACILITY (RNTF) - COCA AREA AND VACUUM BALL (INACTIVE)
 FIGURE 5G

FILE: CAD\MLEBKE\BOEING\SANTA_SUSANA_SWPP\SWPP_FIGS_10_10_12



- Legend**
-  Building
 -  Rock Outcrop
 -  Dirt Road
 -  Fire Hydrant
 -  Surface Water Flow Direction

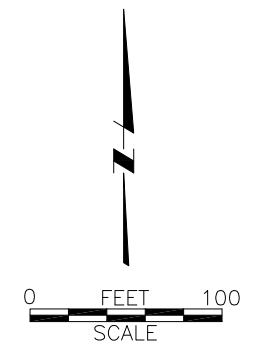

SANTA SUSANA FIELD LABORATORY
 VENTURA COUNTY, CALIFORNIA
 STORMWATER POLLUTION PLAN

**AREA II
 NASA HAZARDOUS WASTE YARD**

FIGURE 5H

FILE: CAD\MUEBKE\BOEING_SANTA_SUSANA_SWPPP_SWPPP_FIGS_10_10_12

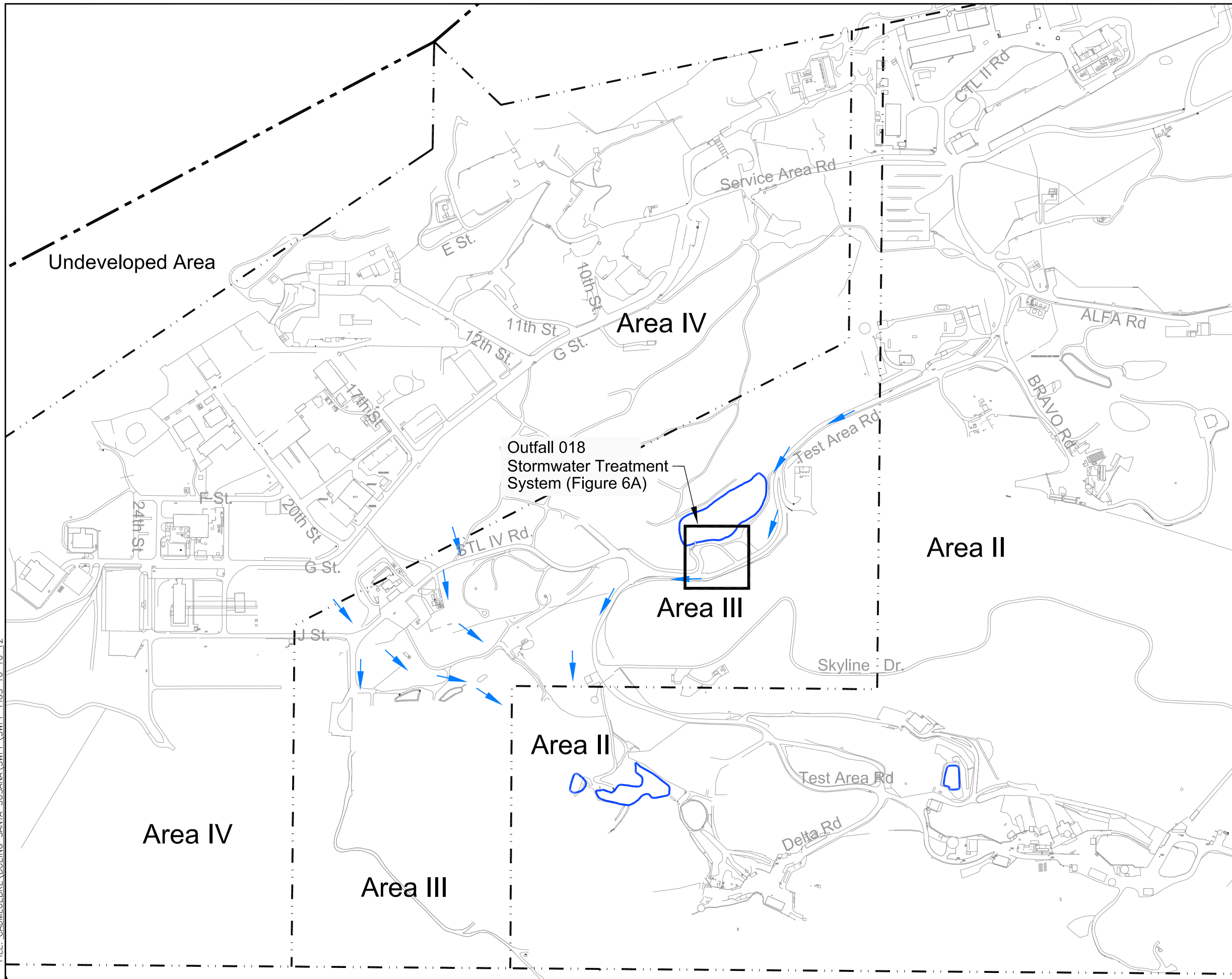

- Legend**
- Property Boundary
 - Administrative Boundary
 - Building
 - Surface Water Flow Direction
 - Dirt Road

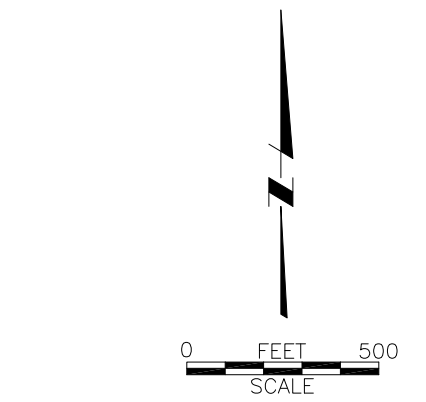

MWH
 SANTA SUSANA FIELD LABORATORY
 VENTURA COUNTY, CALIFORNIA
 STORMWATER POLLUTION PLAN



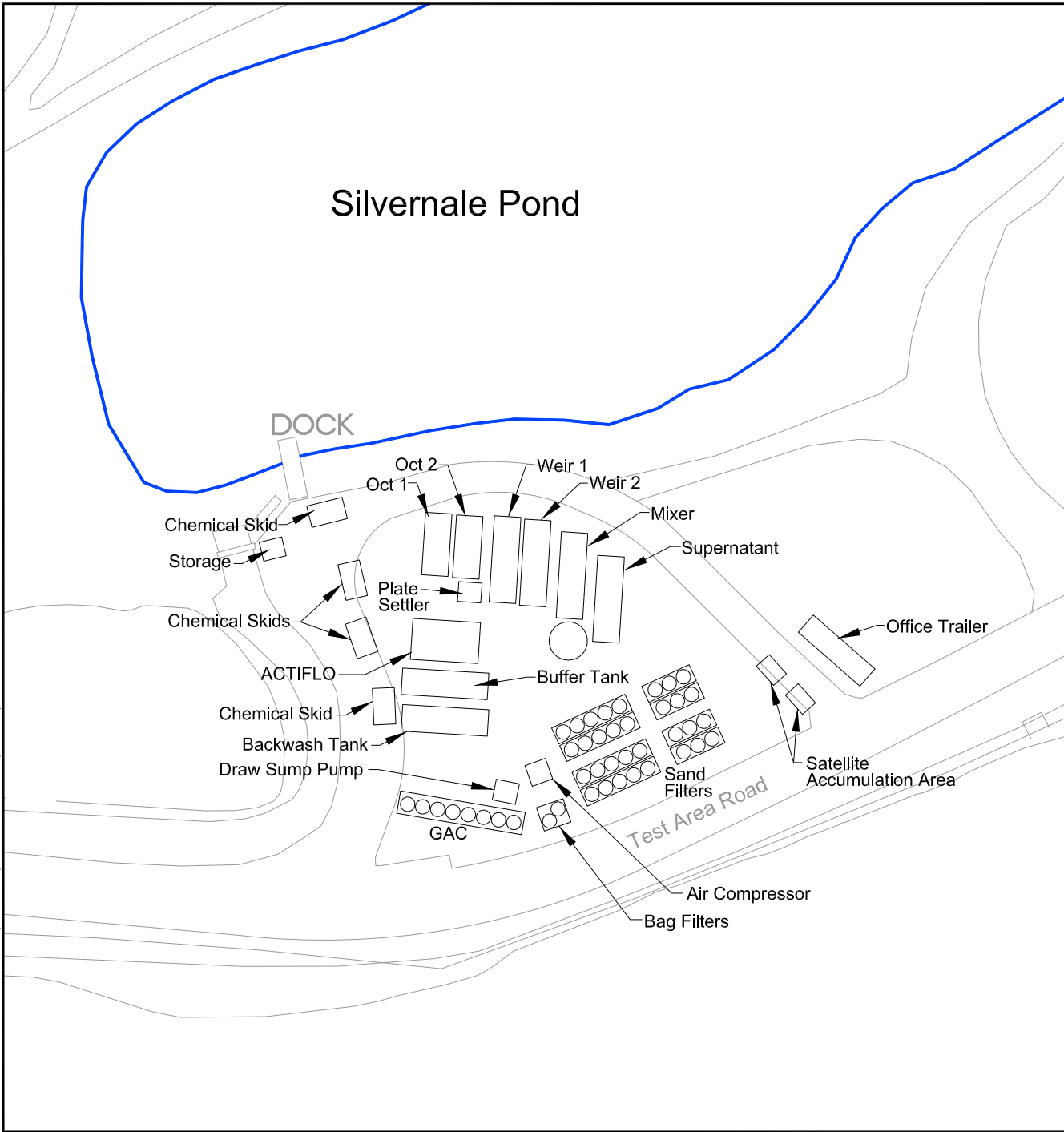

**AREA III
 KEY MAP**

FIGURE 6

FILE: _CAD\M\JEEKE\BOEING\SANTA_SUSANA_SWPP\SWPP_FIGS 10 10 12



Legend

-  Building
-  Rock Outcrop
-  Dirt Road
-  Surface Water Flow Direction

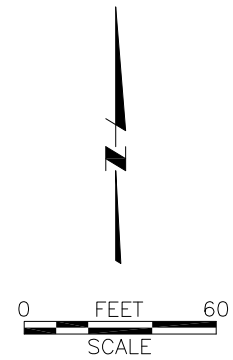

SANTA SUSANA FIELD LABORATORY
 VENTURA COUNTY, CALIFORNIA
 STORMWATER POLLUTION PLAN

**OUTFALL 018
 STORMWATER TREATMENT SYSTEM**

FIGURE 6A

FILE: CAD\MUEBKE\BOEING_SANTA_SUSANA_SWPPP_SWPPP_FIGS_10_10_12

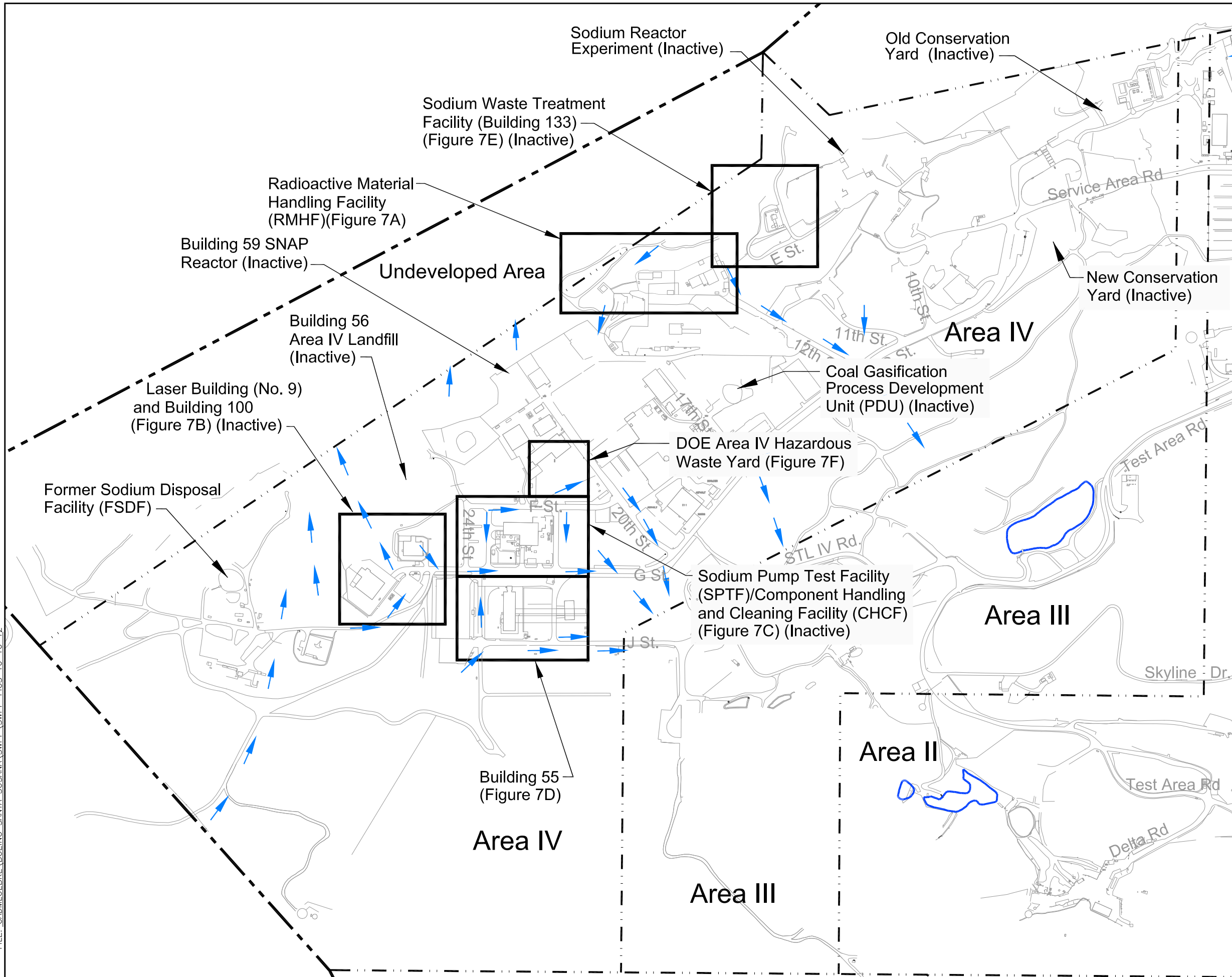

Legend

- Property Boundary
- Administrative Boundary
- Building
- Surface Water Flow Direction
- Dirt Road
- DOE Department of Energy
- SNAP Systems for Nuclear Auxiliary Power

0 FEET 500
SCALE

MWH
SANTA SUSANA FIELD LABORATORY
VENTURA COUNTY, CALIFORNIA
STORMWATER POLLUTION PLAN







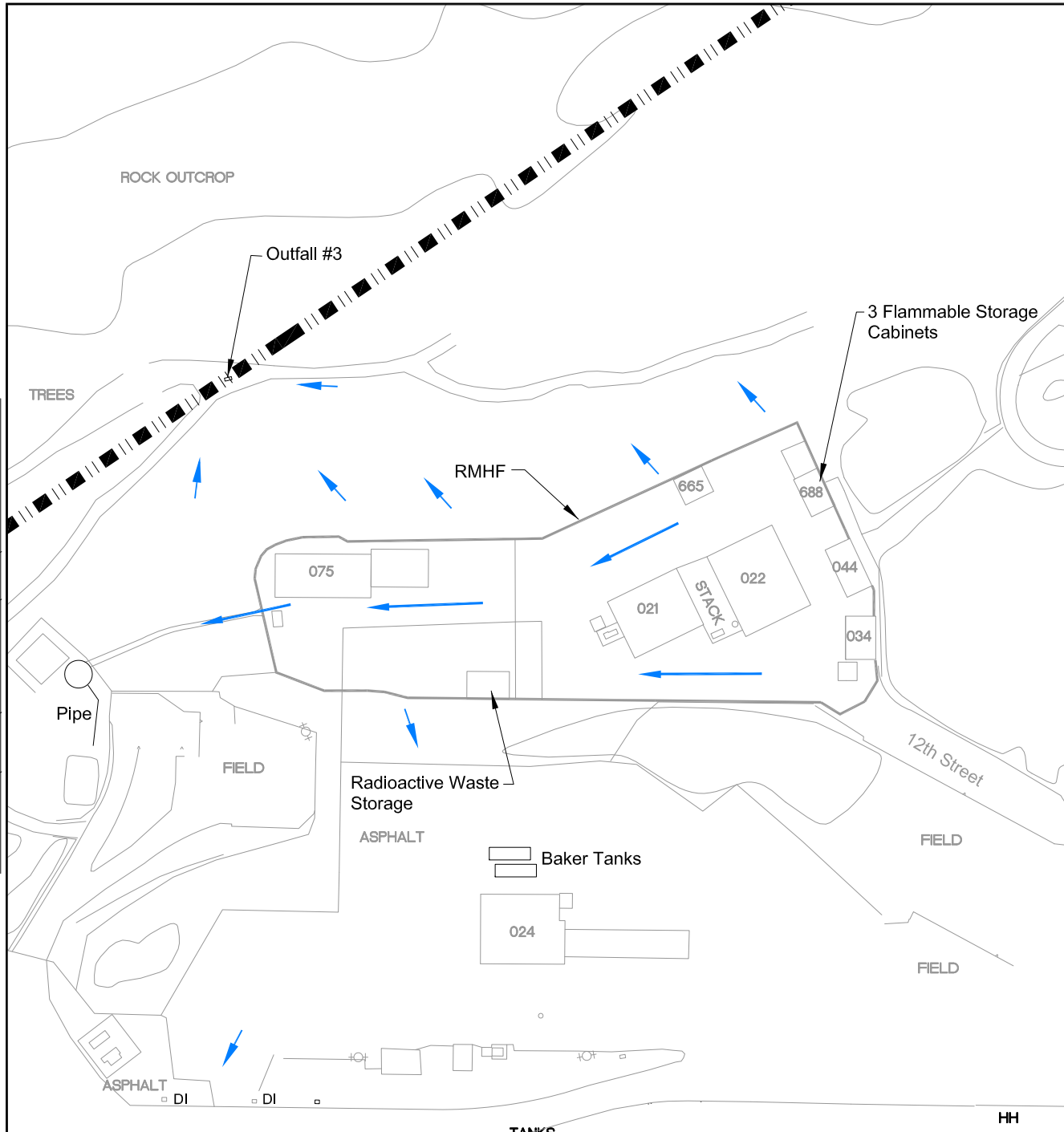

**AREA IV
KEY MAP**

FIGURE 7

FILE: CADMLUEBKE\BOEING\SANTA_SUSANA\SWPP\SWPP_FIGS_10_10_12



Legend

-  Administrative Boundary
-  Building
-  Rock Outcrop
-  Dirt Road
-  Fire Hydrant
-  Drain Inlet
-  Surface Water Flow Direction
-  AOC

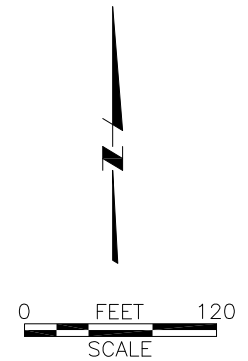

SANTA SUSANA FIELD LABORATORY
 VENTURA COUNTY, CALIFORNIA
 STORMWATER POLLUTION PLAN

AREA IV - RADIOACTIVE MATERIAL
 HANDLING FACILITY (RMHF) (AOC)

FIGURE 7A

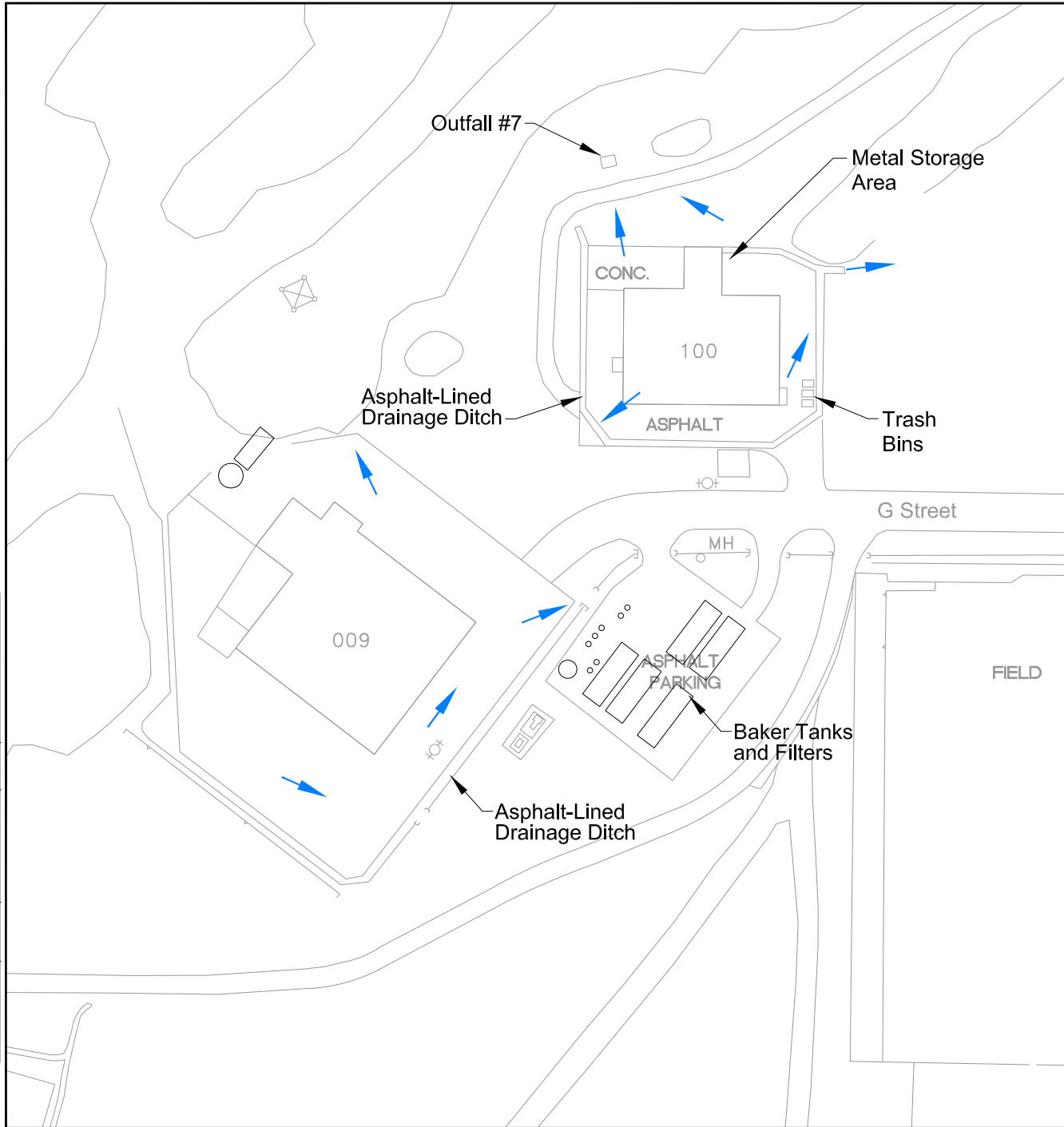

- Legend**
- Building
 - Manhole (MH)
 - Rock Outcrop
 - Dirt Road
 - Fire Hydrant
 - High Voltage Power Line Tower
 - Surface Water Flow Direction

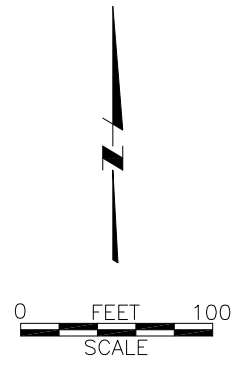







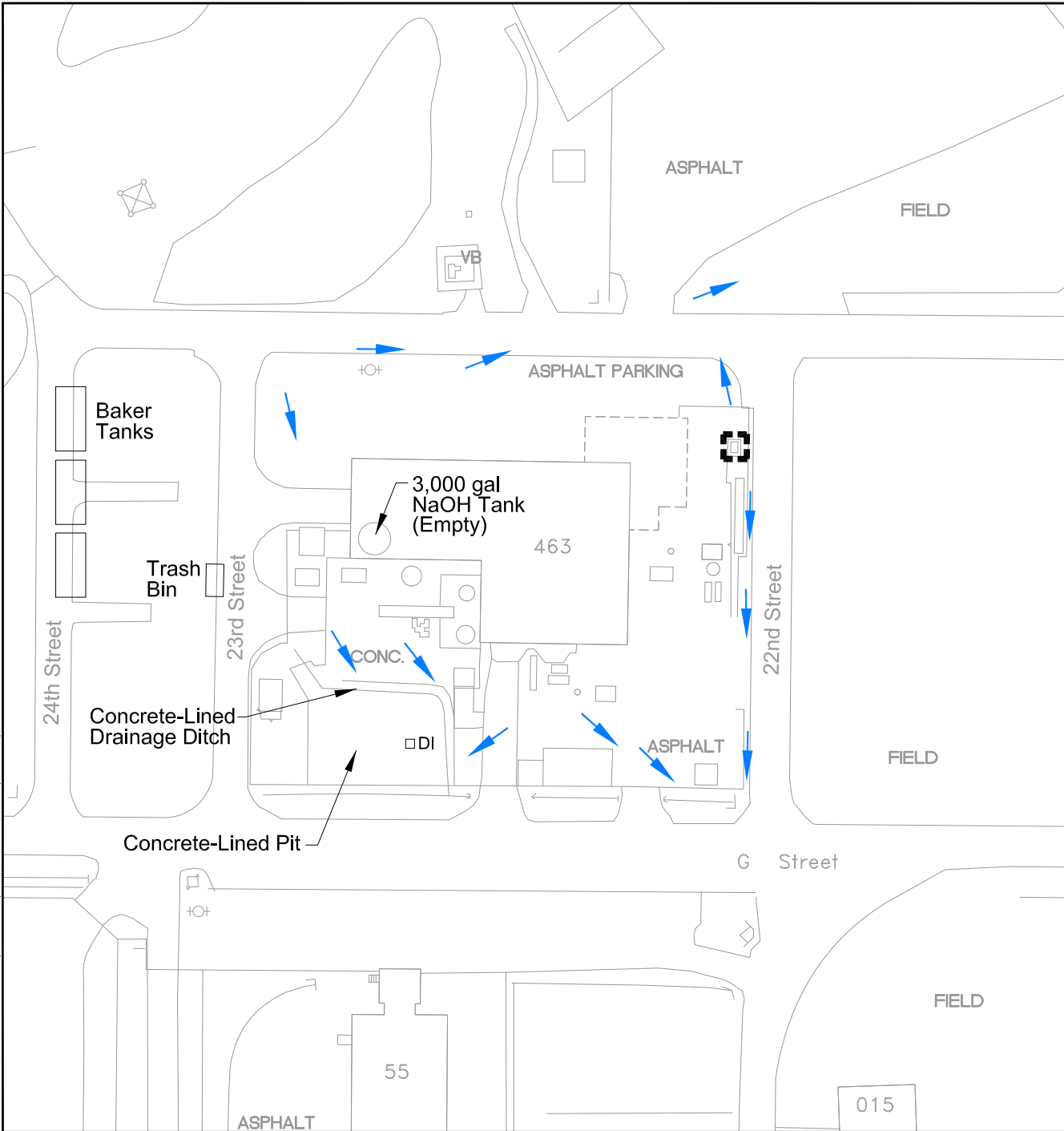



SANTA SUSANA FIELD LABORATORY
VENTURA COUNTY, CALIFORNIA
STORMWATER POLLUTION PLAN
**AREA IV - LASER BUILDING (NO. 9)
AND BUILDING 100 (INACTIVE)**

FIGURE 7B

FILE: _CAD\MUEBEKE\BOEING\ SANTA SUSANA\SWPP\SWPP_FIGS_10_10_12



- Legend**
-  Concrete Containment Berm
 -  Building
 -  Rock Outcrop
 -  Dirt Road
 -  Fire Hydrant
 -  Valve Box
 -  Drain Inlet
 -  High Voltage Power Line Tower
 -  Surface Water Flow Direction
 -  Sodium Hydroxide

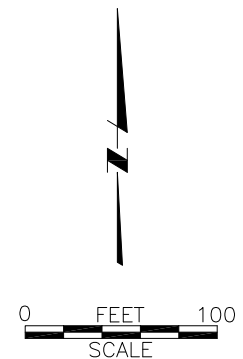





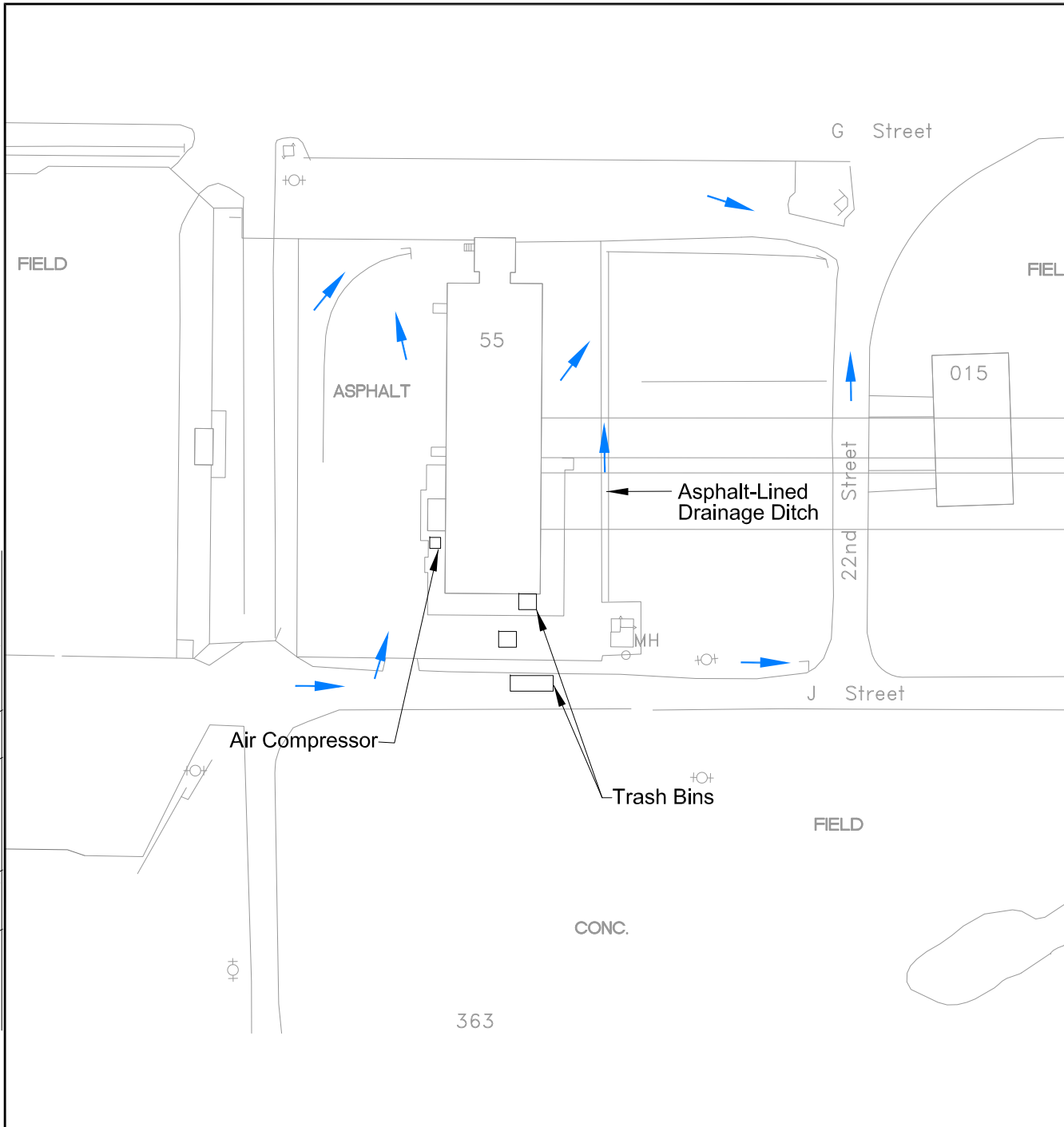

 **MWH**

SANTA SUSANA FIELD LABORATORY
 VENTURA COUNTY, CALIFORNIA
 STORMWATER POLLUTION PLAN

AREA IV - SODIUM PUMP TEST FACILITY (SPTF) COMPONENT HANDLING AND CLEANING FACILITY (CHCF) (INACTIVE)
 FIGURE 7C

FILE: CAD\MLEBKE\BOEING\SANTA_SUSANA\SWPP\SWPP_FIGS.10.10.12



- Legend**
-  Building
 -  Manhole
 -  Rock Outcrop
 -  Dirt Road
 -  Fire Hydrant
 -  Surface Water Flow Direction



SANTA SUSANA FIELD LABORATORY
 VENTURA COUNTY, CALIFORNIA
 STORMWATER POLLUTION PLAN





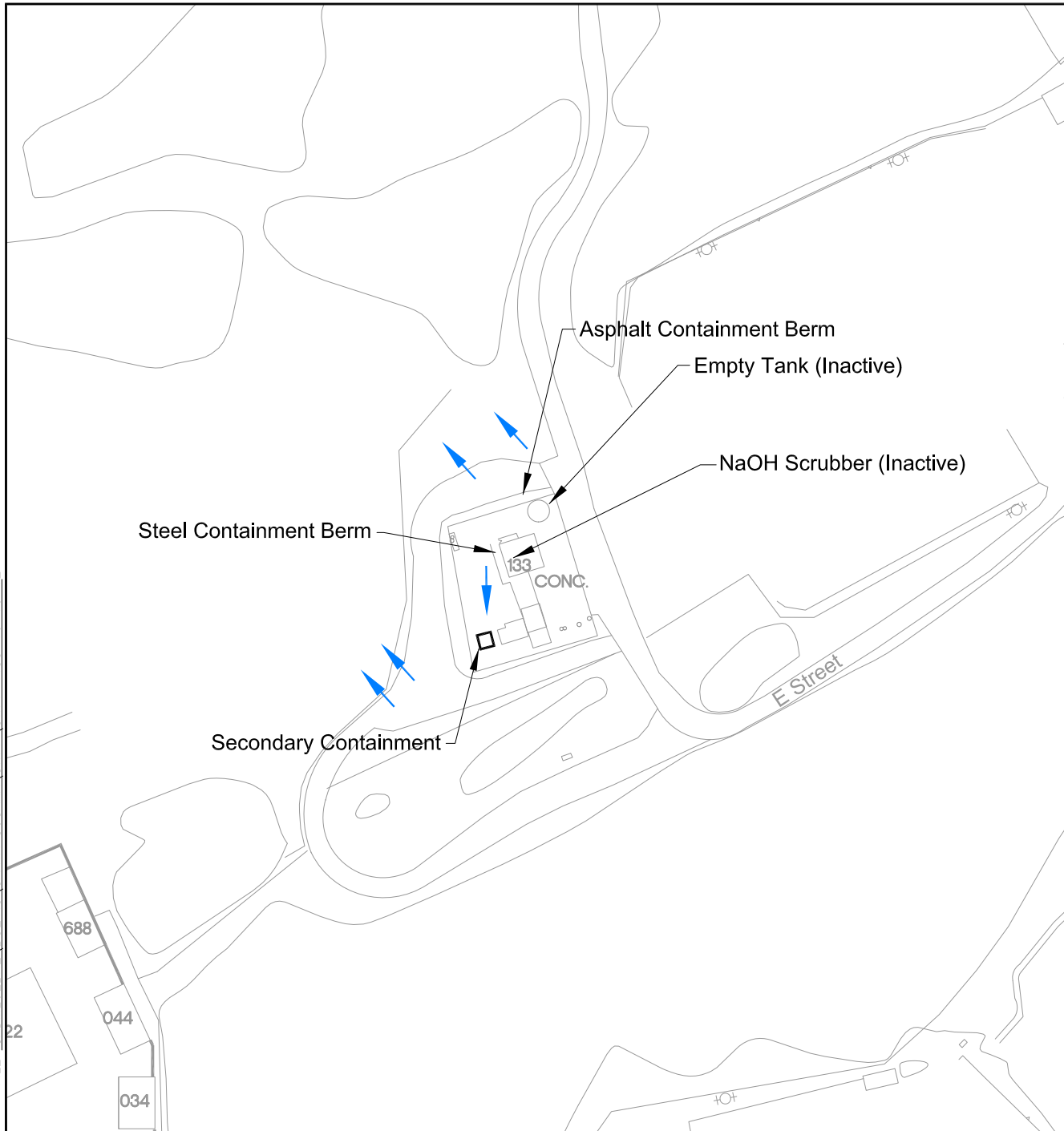

AREA IV - BUILDING 55
 (INACTIVE)

FIGURE 7D

FILE: CAD\MUEBKE\BOEING\SANTA_SUSANA\SWPP\SWPP_FIGS_10_10_12



Legend

-  Concrete Containment Berm
-  Building
-  Rock Outcrop
-  Dirt Road
-  Fire Hydrant
- NaOH** Sodium Hydroxide
-  Surface Water Flow Direction

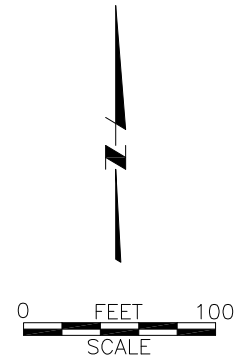







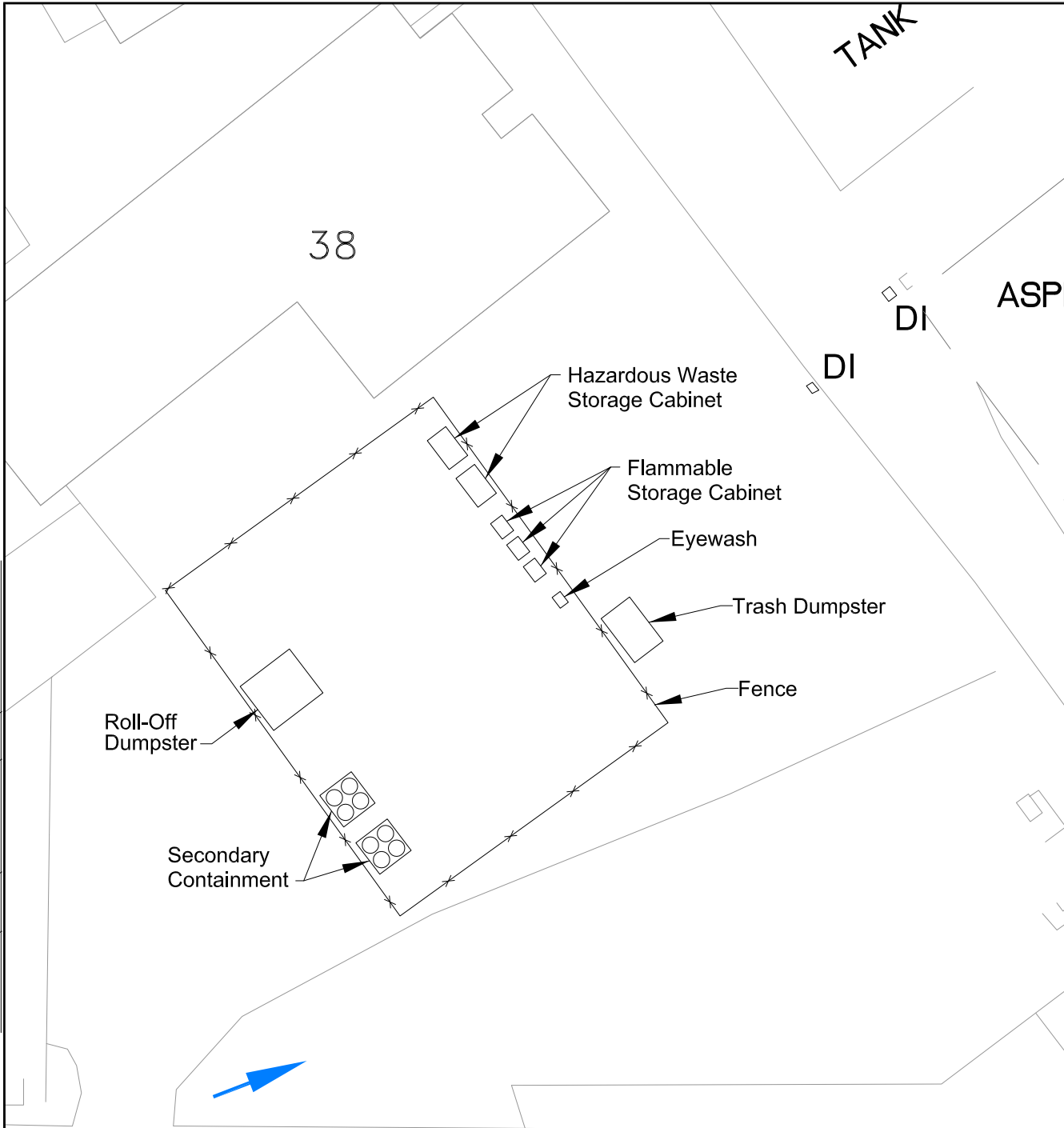

MWH

SANTA SUSANA FIELD LABORATORY
VENTURA COUNTY, CALIFORNIA
STORMWATER POLLUTION PLAN

**AREA IV - SODIUM WASTE TREATMENT
FACILITY (BUILDING 133) (INACTIVE)**

FIGURE 7E



- Legend**
-  Building
 -  MH Manhole
 -  Rock Outcrop
 -  Dirt Road
 -  Fire Hydrant
 -  DI Drain Inlet
 -  High Voltage Power Line Tower
 -  Surface Water Flow Direction



SANTA SUSANA FIELD LABORATORY
 VENTURA COUNTY, CALIFORNIA
 STORMWATER POLLUTION PLAN

**AREA IV
 DOE HAZARDOUS WASTE YARD**

FIGURE 7F

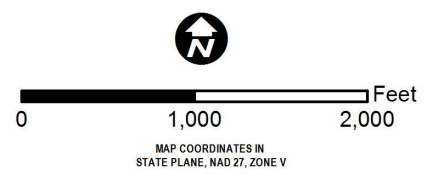
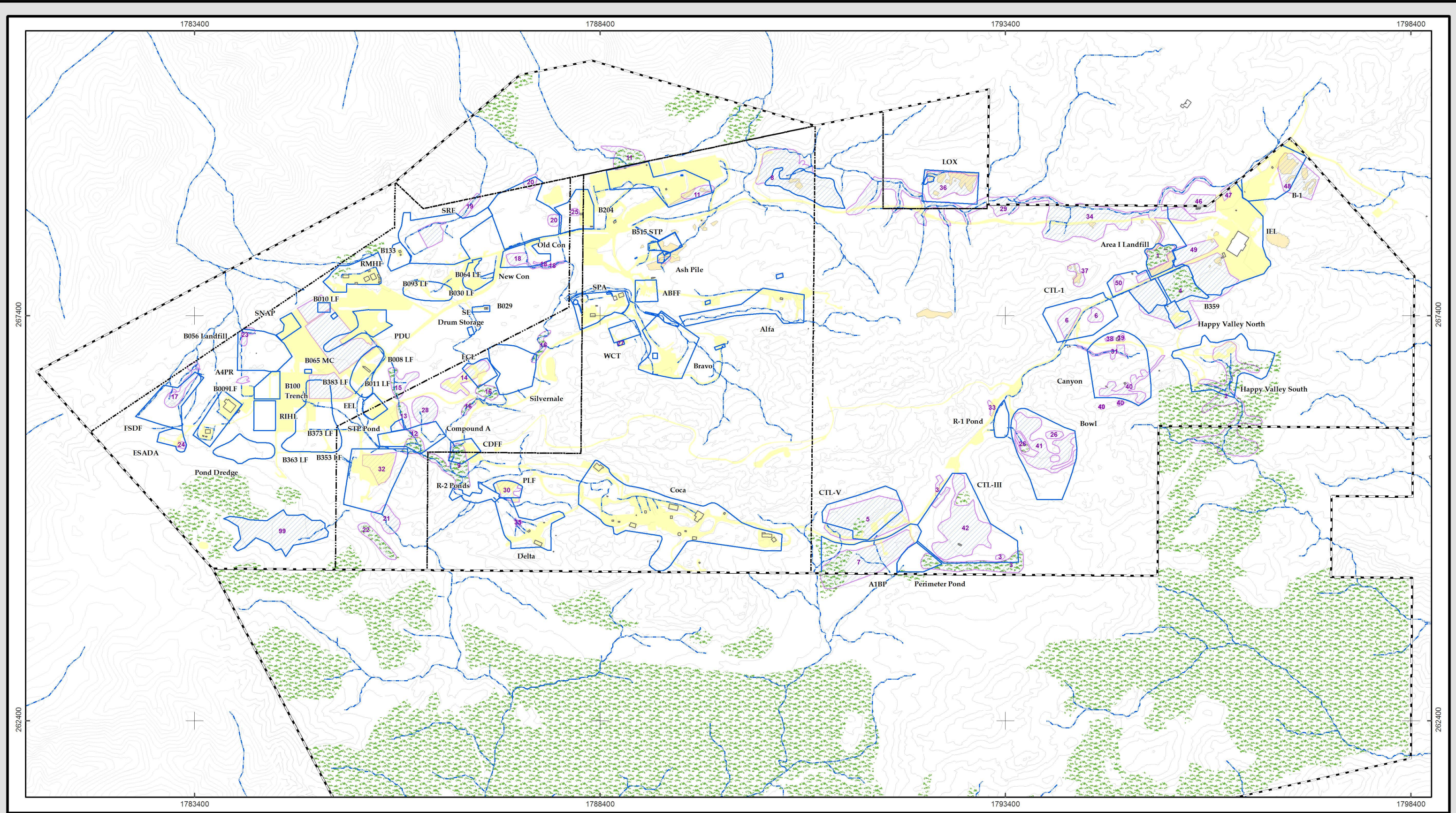

- SSFL Property Boundary
- Administrative Area Boundary
- Structures
- RFI Boundary
- BMP/Potential Soil Erosion & Dust Generation Areas
- SWMU Areas
- Impervious Surface Area
- Aerial Hydromulching Area
- ISRA Excavation Area
- Drainage Pathway
- Elevation Contour

Note: BMP Area boundaries indicate areas where sediment migration/erosion control measures were implemented. Areas shown are approximate.

Potential Soil Erosion, Dust Generation, and Impervious Areas

Date: October 17, 2012
 File: \\usps1s01\del\rocketdyne gis\MasterGISFiles\SiteWideProjects\SWPPP\NFDES_BMP.mxd



APPENDIX A

Waste Discharge Requirements for The Boeing Company,
Santa Susana Field Laboratory (NPDES No. CA0001309)
and Monitoring and Reporting Program No. 6027

**CALIFORNIA REGIONAL WATER QUALITY CONTROL BOARD
LOS ANGELES REGION**

320 W. 4th Street, Suite 200, Los Angeles, California 90013
Phone (213) 576 - 6600 • Fax (213) 576 - 6640
<http://www.waterboards.ca.gov>

**ORDER NO. R4-2010-0090
NPDES NO. CA0001309**

**WASTE DISCHARGE REQUIREMENTS FOR THE BOEING COMPANY,
SANTA SUSANA FIELD LABORATORY**

The following Discharger is subject to waste discharge requirements as set forth in this Order:

Table 1. Discharger Information

Discharger	The Boeing Company
Name of Facility	Santa Susana Field Laboratory
Facility Address	5800 Woolsey Canyon Road
	Canoga Park, CA 91304-1148
	Ventura County
The U.S. Environmental Protection Agency (USEPA) and the Regional Water Quality Control Board have classified this discharge as a minor discharge.	

The discharge by the Owner from the discharge points identified below is subject to waste discharge requirements as set forth in this Order:

April 6, 2010
Revised: May 20, 2010
Revised: June 3, 2010

Table 2. Discharge Location

Discharge Point	Effluent Description	Discharge Point Latitude	Discharge Point Longitude	Receiving Water
001	Storm water runoff and treated groundwater	34°12'49"	118 °41'06"	Bell Creek
002	Storm water runoff	34°12'51"	118 °42'16"	Bell Creek
003	Storm water runoff	34°14'04"	118°42'23"	Arroyo Simi
004	Storm water runoff	34°14'09"	118°14'04"	Arroyo Simi
005	Storm water runoff	34 °13'49"	118 °43'03"	Arroyo Simi
006	Storm water runoff	34 °13'52"	118 °42'59"	Arroyo Simi
007	Storm water runoff	34 °13'50"	118 °42'52"	Arroyo Simi
008	Storm water runoff	34 °13'42"	118 °40'28"	Dayton Canyon Creek
009	Storm water runoff	34 °14'19"	118 °41'38"	Arroyo Simi
010	Storm water runoff	34 °14'17"	118 °41'56"	Arroyo Simi
011	Storm water runoff	34 °13'27"	118 °41'15"	Bell Creek
012	Storm water runoff	34 °13'59"	118 °41'36"	Bell Creek
013	Storm water runoff	34 °13'54"	118 °41'47"	Bell Creek
014	Storm water runoff	34 °14'00"	118 °40'40"	Bell Creek
015	Former Sewage Treatment Plant–STP-1 - No longer used			
016	Former Sewage Treatment Plant–STP-2 - No longer used			
017	Former Sewage Treatment Plant–STP-3 - No longer used			
018	Storm water runoff	34 °13'35"	118 °42'18"	Bell Creek
019	Treated groundwater (downstream of Outfall 001)	34 °12'57"	118 °41'47"	Bell Creek

Table 3. Administrative Information

This Order was adopted by the Regional Water Quality Control Board on:	June 3, 2010
This Order shall become effective on:	July 19, 2010
This Order shall expire on:	April 10, 2014
The Discharger shall file a Report of Waste Discharge in accordance with title 23, California Code of Regulations, as application for issuance of new waste discharge requirements no later than:	October 13, 2013

April 6, 2010
 Revised: May 20, 2010
 Revised: June 3, 2010

IT IS HEREBY ORDERED, that Order No. R4-2009-0058, is terminated upon the effective date of this Order except for enforcement purposes, and, in order to meet the provisions contained in division 7 of the Water Code (commencing with section 13000) and regulations adopted thereunder, and the provisions of the federal Clean Water Act (CWA), and regulations and guidelines adopted thereunder, the Discharger shall comply with the requirements in this Order.

I, Samuel Unger, Interim Executive Officer, do hereby certify that this Order with all attachments is a full, true, and correct copy of an Order adopted by the California Regional Water Quality Control Board, Los Angeles Region, on June 3, 2010.



Samuel Unger, Interim Executive Officer

April 6, 2010
Revised: May 20, 2010
Revised: June 3, 2010

Table of Contents

I.	Facility Information	6
II.	Findings	7
III.	Discharge Prohibitions.....	16
IV.	Effluent Limitations and Discharge Specifications	16
	A. Effluent Limitations.....	16
	1. Final Effluent Limitations.....	16
	2. Final Effluent Limitations – Outfalls 003 - 010.....	20
	3. Benchmarks* – Outfalls 012 - 014	22
	4. Acute Toxicity Limitation Requirements:.....	24
	5. Chronic Toxicity Limitation and Requirements:.....	25
	B. Land Discharge Specifications.....	26
	C. Reclamation Specifications.....	26
V.	Receiving Water Limitations	26
	A. Surface Water Limitations.....	26
	B. Pesticides and PCBs	27
	C. Final Ambient WLAs for Pollutants in Sediment for Storm Water Dischargers	28
	D. Interim Ambient WLAs for Pollutants in Sediment for Storm Water Dischargers	29
	E. Groundwater Limitations	29
VI.	Provisions.....	29
	A. Standard Provisions.....	29
	B. Monitoring and Reporting Program (MRP) Requirements	33
	C. Special Provisions.....	33
	D. Construction, Operation and Maintenance Specifications.....	36
	E. Special Provisions for Municipal Facilities (POTWs Only)	36
	F. Other Special Provisions.....	37
VII.	Compliance Determination	37
	A. Single Constituent Effluent Limitation.	37
	B. Effluent Limitations Expressed as a Sum of Several Constituents.....	37
	C. Multiple Sample Data.....	37
	D. Average Monthly Effluent Limitation (AMEL).	38
	E. Maximum Daily Effluent Limitations (MDEL).....	38
	F. Instantaneous Minimum Effluent Limitation.	39

List of Tables

Table 1.	Discharger Information	1
Table 2.	Discharge Location.....	2
Table 3.	Administrative Information	2
Table 4.	Facility Information	6
Table 5.	Basin Plan Beneficial Uses.....	12
Table 5a.	Basin Plan Beneficial Uses.....	13
Table 6.	Effluent Limitations – Outfalls 011, 018, and 019. Benchmarks* – Outfalls 001 and 002.....	17

List of Attachments

Attachment A – Definitions	A-1
Attachment B – SSFL Location Map.....	B-1
Attachment C – Site Map With Outfall Locations	C-1
Attachment D – Standard Provisions.....	D-1
Attachment E – Monitoring and Reporting Program (MRP No. 6027)	E-1
Attachment F – Fact Sheet.....	F-1
Attachment G – Storm Water Pollution Prevention Plan Requirements	G-1
Attachment H – State Water Board Minimum Levels.....	H-1
Attachment I – List Of Priority Pollutants	I-1
Attachment J – Summary of Reasonable Potential Analysis	J-1

I. FACILITY INFORMATION

The following Discharger is subject to waste discharge requirements as set forth in this Order:

Table 4. Facility Information

Discharger	The Boeing Company
Name of Facility	Santa Susana Field Laboratory
Facility Address	5800 Woolsey Canyon Road
	Canoga Park, CA 91304-1148
	Los Angeles County
Facility Contact, Title, and Phone	Tom Gallacher, Director (818) 466-8161
Mailing Address	5800 Woolsey Canyon Road Canoga Park, CA 91304-1148
Type of Facility	Research and development
Facility Design Flow	Not applicable

II. FINDINGS

The California Regional Water Quality Control Board, Los Angeles Region (hereinafter Regional Water Board), finds:

A. **Background.** The Boeing Company (hereinafter Boeing or Discharger) is currently discharging from the Santa Susana Field Laboratory (hereinafter SSFL or Facility) pursuant to Order No. R4-2009-0058 and National Pollutant Discharge Elimination System (NPDES) Permit No. CA0001309. The Discharger submitted a Report of Waste Discharge (ROWD), dated December 10, 2008, and applied for an NPDES permit renewal. SSFL has the potential (based on a 24-hour duration, 10 year return storm event) to discharge a total of approximately 168 million gallons per day (MGD) of storm water runoff. The Facility has plans to discharge up to 0.3 MGD of treated groundwater from Outfall 019.

This update is the result of the annual review of new data submitted to the Regional Water Board as per the Monitoring and Reporting Program.

B. **Facility Description.** SSFL occupies approximately 2,850 acres and is located at the top of Woolsey Canyon Road in the Simi Hills, Ventura County, California. The Facility is jointly owned by Boeing and the National Aeronautics and Space Administration (NASA). The site is divided into four administrative areas (Area I, II, II, and IV) and undeveloped land areas to both the north and the south. The NASA property includes a portion of Area I and all of Area II. Ninety acres of Area IV are leased to the United States Department of Energy (DOE).

Boeing and its predecessors' operations at SSFL since 1950 included research, development, assembly, disassembly, and testing of nuclear reactors, rocket engines, and chemical lasers. NASA operations included rocket engine assembly, testing, and propellant and fuel storage and loading. DOE conducted past operations in research and development of energy related programs, and seismic testing experiments. During the 1950s to the mid 1970s, volatile organic compounds were utilized for the cleaning of hardware and rocket engine thrust chambers and for the cleaning of other equipment. These solvents migrated into the subsurface, contaminating groundwater primarily with trichloroethylene (TCE) and 1,2-dichloroethylene (1,2-DCE). Current activities on the site are solely related to environmental assessment, remediation, restoration and closure.

C. **Discharge Locations.** The Facility currently has sixteen (16) active outfalls. Fifteen (15) of the outfalls discharge storm water runoff that has historically contained elevated levels of contaminants present on the site. One outfall (Outfall 19) will discharge treated groundwater. A complete list of the outfalls appears on the cover page with the associated types of wastewater discharged and the receiving water. Attachments B and C provide maps of the area around the Facility.

D. **Legal Authorities.** This Order is issued pursuant to section 402 of the federal Clean Water Act (CWA) and implementing regulations adopted by the U.S. Environmental Protection Agency (USEPA) and chapter 5.5, division 7 of the California Water Code

(commencing with section 13370). It shall serve as an NPDES permit for point source discharges from this facility to surface waters. This Order also serves as Waste Discharge Requirements (WDRs) pursuant to article 4, chapter 4, division 7 of the Water Code (commencing with section 13260).

- E. Background and Rationale for Requirements.** The Regional Water Board developed the requirements in this Order based on information submitted as part of the application, through monitoring and reporting programs, and other available information. The Fact Sheet (Attachment F), which contains background information and the rationale for Order requirements, is hereby incorporated into this Order and constitutes part of the Findings for this Order. Attachments A through E and G through J are also incorporated into this Order.
- F. California Environmental Quality Act (CEQA).** Under Water Code section 13389, this action to adopt an NPDES permit is exempt from the provisions of CEQA, Public Resources Code sections 21100-21177.
- G. Technology-based Effluent Limitations.** Section 301(b) of the CWA and implementing USEPA permit regulations at section 122.44, title 40 of the Code of Federal Regulations¹, require that permits include conditions meeting applicable technology-based requirements at a minimum, and any more stringent effluent limitations necessary to meet applicable water quality standards. The discharge authorized by this Order must meet minimum federal technology-based requirements based on Best Professional Judgment (BPJ) in accordance with Part 125, section 125.3. A detailed discussion of the technology-based effluent limitations development is included in the Fact Sheet (Attachment F).
- H. Water Quality-Based Effluent Limitations.** Section 301(b) of the CWA and section 122.44(d) require that permits include limitations more stringent than applicable federal technology-based requirements where necessary to achieve applicable water quality standards.

Section 122.44(d)(1)(i) mandates that permits include effluent limitations for all pollutants that are or may be discharged at levels that have the reasonable potential to cause or contribute to an exceedance of a water quality standard, including numeric and narrative objectives within a standard. Where reasonable potential has been established for a pollutant, but there is no numeric criterion or objective for the pollutant, water quality-based effluent limitations (WQBELs) must be established using: (1) USEPA criteria guidance under CWA section 304(a), supplemented where necessary by other relevant information; (2) an indicator parameter for the pollutant of concern; or (3) a calculated numeric water quality criterion, such as a proposed state criterion or policy interpreting the state's narrative criterion, supplemented with other relevant information, as provided in section 122.44(d)(1)(vi).

I. Watershed Management Approach and Total Maximum Daily Loads (TMDLs)

The Regional Water Board has implemented the Watershed Management Approach

All further statutory references are to title 40 of the Code of Federal Regulations unless otherwise indicated.

to address water quality issues in the region. Watershed management may include diverse issues as defined by stakeholders to identify comprehensive solutions to protect maintain, enhance, and restore water quality and beneficial uses. To achieve this goal, the Watershed Management Approach integrates the Regional Water Board's "many diverse programs, particularly TMDLs, to better assess cumulative impacts of pollutants from all point and non point sources. A TMDL is a tool for implementing water quality standards and is based on the relationship between pollution sources and in-stream water quality conditions. The TMDL establishes the allowable loadings or other quantifiable parameters for a water body and thereby provides the basis to establish water quality based controls. These controls should provide the pollution reduction necessary for a water body to meet water quality standards. This process facilitates the development of watershed-specific solutions that balance the environmental and economic impacts within the watershed. The TMDLs will establish waste load allocations (WLAs) and load allocations (LAs) for point and non-point sources, and will result in achieving water quality standards for the water body. Discharges from the SSFL enter both the Los Angeles River Watershed and the Calleguas Creek Watershed.

Certain receiving waters in the Los Angeles and Ventura County watersheds do not fully support beneficial uses and therefore have been classified as impaired on the 2006 303(d) list and have been scheduled for TMDL development. The USEPA approved the State's 2006 303(d) list of impaired water bodies on June 28, 2007. Bell Creek, a tributary to the Los Angeles River, is one of the receiving waters for discharges from the SSFL on the south side. Bell Creek is on the 2006 Clean Water Act 303 (d) list. Coliform bacteria is the pollutant listed. Downstream receiving waters are listed for: coliform bacteria, volatiles (1,1-dichloroethane (1,1-DCE) and vinyl chloride, tetrachloroethylene (PCE), and trichloroethylene (TCE)), trash, and oil.

The storm water runoff discharge from Outfalls 003 through 007, 009 and 010, when it is sufficient flows to the Calleguas Creek Reach 7 (formerly Arroyo Simi Reach 1 – Hydrological Unit 403.62). The stressors listed in the 2006 State Board's California 303(d) list for this reach of Arroyo Simi are: boron, chloride, sulfates, fecal coliform, and total dissolved solids.

TMDLs have been developed for a number of the stressors listed for both the Los Angeles River Watershed and the Calleguas Creek Watershed. Following is a summary of each of the applicable TMDLs.

Nutrient TMDL for Los Angeles River: The TMDL for Nitrogen (nutrients) in the Los Angeles (LA) River received Regional Water Board approval on July 10, 2003 (Resolution No. 03-009) and State Board approval with the adoption of Order 2003-0074 on November 19, 2003. The Office of Administrative Law (OAL) and USEPA approval dates were February 27, 2003 and March 18, 2003, respectively. The Regional Water Board filed a Notice of Decision with the California Resources Agency on March 23, 2004, and the TMDL was effective as of that date. Subsequently, Regional Water Board revised the interim effluent limit for ammonia by adoption of Resolution 2003-016 on December 4, 2003. It became effective on September 27, 2004. This permit includes effluent limits based on the nutrient TMDL established for the Los Angeles River.

Los Angeles River Metals TMDL: The TMDL for metals in the LA River was approved by the Regional Water Board during the June 2, 2005, hearing (Resolution No. 2005-006). The State Board approved the TMDL on October 20, 2005, OAL and EPA approvals were received on December 9, 2005, and December 22, 2005, respectively. The LA River Metals TMDL establishes numeric water quality targets that are based on objectives established by USEPA in the CTR. An amendment to the metals TMDL was adopted by the Regional Water Board on September 6, 2007. State Board, OAL, and USEPA approvals occurred on June 17, 2008, October 17, 2008, and October 29, 2008. This permit includes wet weather limits for cadmium, and copper based on the LA River Metals TMDL. The permit also includes dry weather TMDL based limits for copper. The limits for lead are the same for both dry and wet weather conditions.

Los Angeles River Trash TMDL: The LA River Trash TMDL (Resolution No. 2001-013) was adopted by the Regional Water Board on September 19, 2001. This TMDL established a numeric target of zero trash in the river. The TMDL became effective on August 28, 2002.

There were a number of challenges to the LA River Trash TMDL. The consideration of the challenges resulted in a requirement that the TMDL be set aside until the California Environmental Quality Act (CEQA) requirements were satisfied. The resolution (Resolution No. 2006-013) became effective on July 17, 2006. On September 23, 2008, a new Basin Plan Amendment Resolution 07-012 Trash TMDL for the Los Angeles River became effective. It is implemented through the Municipal Separate Storm Sewer Systems (MS4) NPDES Permit Program. This permit does not include requirements associated with the LA River Trash TMDL.

Calleguas Creek Watershed Salts TMDL (Resolution No. R4-2007-016): The Calleguas Creek Watershed Salts TMDL was adopted by the Regional Water Board on October 4, 2007. After approvals by the State Board, OAL and EPA the TMDL became effective on December 2, 2008. It includes interim and final dry weather WLAs for urban runoff. These WLAs are not implemented in this permit since there are no discharges to the Arroyo Simi during dry weather.

Calleguas Creek Nitrogen Compounds and Related Effects TMDL. On October 24, 2002, the Regional Water Board adopted Resolution No. 2002-017, Amendment to the *Basin Plan for the Los Angeles Region* to Include a TMDL for Nitrogen Compounds and Related Effects in Calleguas Creek (*Nitrogen Compounds and Related Effects TMDL*). The TMDL became effective on July 16, 2003.

The WLAs for the Calleguas Creek Nitrogen TMDL were revised by adoption of Regional Water Board Resolution No. R4-2008-009 (adopted September 11, 2008). It became effective on October 15, 2009. Both of the TMDLs for Nitrogen in Calleguas Creek included WLAs for the publicly owned treatment works (POTW) located in the watershed.

TMDL for Toxicity, Chlorpyrifos, and Diazinon in the Calleguas Creek, its tributaries and Mugu Lagoon (Resolution No. R4-2005-009) was adopted by the Regional Water Board on July 7, 2005. The approved TMDL includes numeric targets, WLAs, and load allocations for toxicity, chlorpyrifos, and diazinon. The appropriate waste load allocations are translated into permit limits and they are included in this Order.

Resolution No. R4-2005-0010, a TMDL for Organochlorine (OC) Pesticides, Polychlorinated Biphenyl (PCBs) and Siltation in Calleguas Creek, its tributaries, and Mugu Lagoon, was also approved by the Regional Water Board on July 7, 2005. The TMDL establishes water column targets, fish tissue targets, and sediment targets to ensure the protection of beneficial uses. The waste load allocations for OC pesticides and PCBs in sediment have been translated directly into ambient contaminant concentrations in the sediment of Arroyo Simi. Those ambient contaminant concentrations are compared directly to sediment concentrations measured in the samples collected to determine compliance. The waste load allocations in the water column are translated into effluent limitations and are included as receiving water effluent limits.

Resolution R4-2006-012, the TMDL for Metals and Selenium for Calleguas Creek, its tributaries and Mugu Lagoon became effective on March 26, 2007. The TMDL establishes numeric targets for dissolved copper, nickel, and zinc, and in total recoverable mercury and selenium. It also includes fish tissue targets for mercury, bird egg targets for mercury and selenium and sediment quality guidelines for copper, nickel, and zinc. This TMDL has been implemented as detailed in the Fact Sheet.

Revolon Slough & Beardsley Wash Trash TMDL. This TMDL was adopted by the Regional Water Board on June 7, 2007, and became effective on March 6, 2008. Since discharges from SSFL do not enter Revolon Slough or Beardsley Wash criteria included in the TMDL have not been implemented in this Order.

- J. **Water Quality Control Plans.** The Regional Water Board adopted a Water Quality Control Plan for the Los Angeles Region (hereinafter Basin Plan) on June 13, 1994, that designates beneficial uses, establishes water quality objectives, and contains implementation programs and policies to achieve those objectives for all waters addressed through the plan. In addition, the Basin Plan implements State Water Resources Control Board (State Water Board) Resolution No. 88-63, which established state policy that all waters, with certain exceptions, should be considered suitable or potentially suitable for municipal or domestic supply.

Discharges from the SSFL facility enter two watersheds. Discharges to the south and east of the facility enter Bell Creek and Dayton Canyon Creek, tributaries to the Los Angeles River. The beneficial uses applicable to the Bell Creek, Dayton Canyon Creek and the Los Angeles River upstream of Figueroa Street are listed below:

Table 5. Basin Plan Beneficial Uses

Discharge Point	Receiving Water Name	Beneficial Use(s)
008	Dayton Canyon Creek – Hydrologic Unit 405.21	Existing: wildlife habitat Intermittent: groundwater recharge, contact and non-contact water recreation; warm freshwater habitat.
001, 002, 011, 012, 013, 014, 018, 019	Bell Creek – Hydrologic Unit 405.21	Existing: wildlife habitat Intermittent: groundwater recharge, contact and non-contact water recreation; warm freshwater habitat.
001, 002, 011, 012, 013, 014, 018, 019	Los Angeles River upstream of Figueroa St. – Hydrologic Unit 405.21-	Existing: groundwater recharge; contact and non-contact water recreation, warm freshwater habitat; wildlife habitat; and wetland habitat. Potential: industrial service supply.

Dayton Canyon Creek, Bell Creek and many of the reaches of the Los Angeles River, except for the estuary, have municipal and domestic supply (MUN) listed as a potential beneficial use in the Basin Plan. This is consistent with Regional Water Board Resolution 89-03; however the Regional Water Board has only conditionally designated the MUN beneficial uses and at this time, the Regional Water Board cannot establish effluent limitations designed to protect the conditional designation.

Table 5a. Basin Plan Beneficial Uses

Discharge Point	Receiving Water Name	Beneficial Use(s)
003, 004, 005, 006, 007, 009, 010	Arroyo Simi – Hydrologic Unit 403.62	Existing: wildlife habitat, rare, threatened, or endangered species habitat, Intermittent: industrial process supply, groundwater recharge, freshwater replenishment, contact and non-contact water recreation, warm freshwater habitat.
003, 004, 005, 006, 007, 009, 010	Arroyo Las Posas – Hydrologic Unit 403.62	Existing: groundwater recharge, freshwater replenishment, contact and non-contact water recreation, warm freshwater habitat, wildlife habitat, Potential: industrial process supply, industrial service supply, agricultural supply, and cold freshwater habitat.
003, 004, 005, 006, 007, 009, 010	Calleguas Creek Hydrologic Unit 403.12	Existing: industrial service supply, industrial process supply, agricultural supply, groundwater recharge, contact and non-contact water recreation, warm freshwater habitat, and wildlife habitat.

All of the reaches of Calleguas Creek, except the estuary, also include conditional municipal and domestic supply designations as an intermittent or potential beneficial use in the Basin Plan. Requirements of this Order implement the Basin Plan.

The State Water Board adopted the *Water Quality Control Plan for Control of Temperature in the Coastal and Interstate Water and Enclosed Bays and Estuaries of California* (Thermal Plan) on May 18, 1972, and amended this plan on September 18, 1975. This plan along with a white paper developed by Regional Water Board staff entitled *Temperature and Dissolved Oxygen Impacts on Biota in Tidal Estuaries and Enclosed Bays in the Los Angeles Region* contains temperature objectives for inland and coastal surface waters. Requirements of this Order implement the Thermal Plan and the findings included in the white paper.

- K. **National Toxics Rule (NTR) and California Toxics Rule (CTR).** USEPA adopted the NTR on December 22, 1992, and later amended it on May 4, 1995, and November 9, 1999. About forty criteria in the NTR applied in California. On May 18, 2000, USEPA adopted the CTR. The CTR promulgated new toxics criteria for California and, in addition, incorporated the previously adopted NTR criteria that were applicable in the state. The CTR was amended on February 13, 2001. These rules contain water quality criteria for priority pollutants.

- L. **State Implementation Policy.** On March 2, 2000, the State Water Board adopted the Policy for Implementation of Toxics Standards for Inland Surface Waters, Enclosed Bays, and Estuaries of California (State Implementation Policy or SIP). The SIP became effective on April 28, 2000, with respect to the priority pollutant criteria promulgated for California by the USEPA through the NTR and to the priority pollutant objectives established by the Regional Water Board in the Basin Plan. The SIP became effective on May 18, 2000, with respect to the priority pollutant criteria promulgated by the USEPA through the CTR. The State Water Board adopted amendments to the SIP on February 24, 2005, that became effective on July 13, 2005. The SIP establishes implementation provisions for priority pollutant criteria and objectives and provisions for chronic toxicity control. Requirements of this Order implement the SIP.
- M. **Compliance Schedules and Interim Requirements.** Section 2.1 of the SIP provides that, based on a Discharger's request and demonstration that it is infeasible for an existing Discharger to achieve immediate compliance with an effluent limitation derived from a CTR criterion, compliance schedules may be allowed in an NPDES permit. Unless an exception has been granted under section 5.3 of the SIP, a compliance schedule may not exceed 5 years from the date that the permit is issued or reissued, nor may it extend beyond 10 years from the effective date of the SIP (or May 17, 2010) to establish and comply with CTR criterion-based effluent limitations. Where a compliance schedule for a final effluent limitation exceeds 1 year, the Order must include interim numeric limitations for that constituent or parameter. Where allowed by the Water Quality Control Plan Los Angeles Region, compliance schedules and interim effluent limitations or discharge specifications may also be granted to allow time to implement a new or revised water quality objective. This Order does not include a compliance schedule or interim effluent limitations.
- N. **Alaska Rule.** On March 30, 2000, USEPA revised its regulation that specifies when new and revised state and tribal water quality standards (WQS) become effective for CWA purposes. (40 C.F.R. § 131.21; 65 Fed. Reg. 24641 (April 27, 2000).) Under the revised regulation (also known as the Alaska rule), new and revised standards submitted to USEPA after May 30, 2000, must be approved by USEPA before being used for CWA purposes. The final rule also provides that standards already in effect and submitted to USEPA by May 30, 2000, may be used for CWA purposes, whether or not approved by USEPA.
- O. **Antidegradation Policy.** Section 131.12 requires that the state water quality standards include an antidegradation policy consistent with the federal policy. The State Water Board established California's antidegradation policy in State Water Board Resolution No. 68-16. Resolution No. 68-16 incorporates the federal antidegradation policy where the federal policy applies under federal law. Resolution No. 68-16 requires that existing quality of waters be maintained unless degradation is justified based on specific findings. The Regional Water Board's Basin Plan implements, and incorporates by reference, both the state and federal antidegradation policies. As discussed in detail in the Fact Sheet the permitted discharge is consistent with the antidegradation provision of section 131.12 and State Water Board Resolution No. 68-16.

- P. Anti-Backsliding Requirements.** Sections 402(o)(2) and 303(d)(4) of the CWA and federal regulations at title 40, Code of Federal Regulations section 122.44(l) prohibit backsliding in NPDES permits. These anti-backsliding provisions require effluent limitations in a reissued permit to be as stringent as those in the previous permit, with some exceptions where limitations may be relaxed. All effluent limitations in this Order are at least as stringent as the effluent limitations in the previous Order No. R4-2009-0058.
- Q. Endangered Species Act.** This Order does not authorize any act that results in the taking of a threatened or endangered species or any act that is now prohibited, or becomes prohibited in the future, under either the California Endangered Species Act (Fish and Game Code sections 2050 to 2097) or the Federal Endangered Species Act (16 U.S.C.A. sections 1531 to 1544). This Order requires compliance with effluent limits, receiving water limits, and other requirements to protect the beneficial uses of waters of the state. The discharger is responsible for meeting all requirements of the applicable Endangered Species Act.
- R. Monitoring and Reporting.** Section 122.48 requires that all NPDES permits specify requirements for recording and reporting monitoring results. Water Code sections 13267 and 13383 authorizes the Regional Water Board to require technical and monitoring reports. The Monitoring and Reporting Program establishes monitoring and reporting requirements to implement federal and State requirements. This Monitoring and Reporting Program is provided in Attachment E.
- S. Standard and Special Provisions.** Standard Provisions, which apply to all NPDES permits in accordance with section 122.41, and additional conditions applicable to specified categories of permits in accordance with section 122.42, are provided in Attachment D. The discharger must comply with all standard provisions and with those additional conditions that are applicable under section 122.42. The Regional Water Board has also included in this Order special provisions applicable to the Discharger. A rationale for the special provisions contained in this Order is provided in the attached Fact Sheet.
- T. Provisions and Requirements Implementing State Law.** The provisions/requirements in subsections IV.B, IV.C, V.B, and VI.C. of this Order are included to implement state law only. These provisions/requirements are not required or authorized under the federal CWA; consequently, violations of these provisions/requirements are not subject to the enforcement remedies that are available for NPDES violations.
- U. Notification of Interested Parties.** The Regional Water Board has notified the Discharger and interested agencies and persons of its intent to prescribe Waste Discharge Requirements for the discharge and has provided them with an opportunity to submit their written comments and recommendations. Details of notification are provided in the Fact Sheet of this Order.

- V. **Consideration of Public Comment.** The Regional Water Board, in a public meeting, heard and considered all comments pertaining to the discharge. Details of the Public Hearing are provided in the Fact Sheet of this Order.

THEREFORE, IT IS HEREBY ORDERED, that this Order supercedes Order No. R4-2009-0058 except for enforcement purposes, and, in order to meet the provisions contained in division 7 of the Water Code (commencing with section 13000) and regulations adopted thereunder, and the provisions of the federal Clean Water Act (CWA) and regulations and guidelines adopted thereunder, the Discharger shall comply with the requirements in this Order.

III. DISCHARGE PROHIBITIONS

- A. Wastes discharged shall be limited to 168 mgd of storm water runoff and 0.3 mgd of treated groundwater, as proposed.
- B. Discharges of water, materials, radiological wastes, thermal wastes, elevated temperature wastes, toxic wastes, deleterious substances, or wastes other than those authorized by this Order, to a storm drain system, Bell Creek, Dayton Canyon Creek, the Arroyo Simi, or other waters of the State, are prohibited.
- C. Neither the treatment nor the discharge of pollutants shall create pollution, contamination, or a nuisance as defined by Section 13050 of the Water Code.
- D. Wastes discharged shall not contain any substances in concentrations toxic to human, animal, plant, or aquatic life.
- E. The discharge shall not cause a violation of any applicable water quality standards for receiving waters adopted by the Regional Water Board or the State Water Resources Control Board as required by the Federal CWA and regulations adopted thereunder. If more stringent applicable water quality standards are promulgated or approved pursuant to section 303 of the Federal CWA, and amendments thereto, the Board will revise and modify this Order in accordance with such more stringent standards.
- F. The discharge of any radiological, chemical, or biological warfare agent or high level radiological waste is prohibited.
- G. Any discharge of wastes at any point(s) other than specifically described in this Order is prohibited, and constitutes a violation of the Order.
- H. There shall be no discharge of PCB compounds, such as those once commonly used for transformer fluid.

IV. EFFLUENT LIMITATIONS AND DISCHARGE SPECIFICATIONS

A. Effluent Limitations

1. Final Effluent Limitations

- a. The discharge of storm water runoff only from Outfall 018 and Outfall 011 with constituents in excess of the daily maximum limitations listed below is prohibited.

Discharges from Outfall 019 of treated groundwater must demonstrate compliance with the daily maximum and monthly average effluent limitations.

Table 6. Effluent Limitations – Outfalls 011, 018, and 019. Benchmarks* – Outfalls 001 and 002.

Parameter	Units	Effluent Limitations		
		Average Monthly ¹⁴	Maximum Daily	Instantaneous Minimum/Maximum
<i>Conventional Pollutants</i>				
Biochemical Oxygen Demand (BOD)(5-day @20 Deg. C)	mg/L	20	30	--
	lbs/day ²	26,700	40,032	--
Oil and Grease	mg/L	10	15	--
	lbs/day ²	13,344	20,016	--
pH	s.u.	--	--	6.5/8.5
Total Suspended Solids (TSS) ¹	mg/L	15	45	--
	lbs/day ²	20,016	60,048	--
<i>Priority Pollutants</i>				
Antimony, Total Recoverable ⁵	µg/L	--	6.0	--
	lbs/day ²	--	8.0	--
Arsenic, Total Recoverable ⁵	µg/L	--	10	--
	lbs/day ²	--	67	--
Beryllium, Total Recoverable ⁵	µg/L	--	4.0	--
	lbs/day ²	--	5.3	--
Cadmium, Total Recoverable ⁵	µg/L	2.0	4.0/3.1 ⁷	--
	lbs/day ²	2.7	5.3/4.1 ⁷	--
Chromium VI, Total Recoverable ^{5,6}	µg/L	8	16	--
	lbs/day ²	11	22	--
Copper, Total Recoverable ⁵	µg/L	7.1	14	--
	lbs/day ²	10	19	--
Lead, Total Recoverable ⁵	µg/L	2.6	5.2	--
	lbs/day ²	3.5	6.9	--
Mercury, Total Recoverable ⁵	µg/L	0.05	0.10	--
	lbs/day ²	0.07	0.13	--
Nickel, Total Recoverable ⁵	µg/L	35	96	--
	lbs/day ²	47	128	--

Parameter	Units	Effluent Limitations		
		Average Monthly ¹⁴	Maximum Daily	Instantaneous Minimum/Maximum
Selenium, Total Recoverable ⁵	µg/L	4.1	8.2/5 ⁸	--
	lbs/day ²	5.5	11/6.7 ⁸	--
Silver, Total Recoverable ⁵	µg/L	2.0	4.1	--
	lbs/day ²	2.7	5.5	--
Thallium, Total Recoverable ⁵	µg/L	--	2.0	--
	lbs/day ²	--	2.7	--
Zinc, Total Recoverable ⁵	µg/L	54	119	--
	lbs/day ²	72	159	--
Cyanide	µg/L	4.3	8.5	--
	lbs/day ²	5.7	11	--
1,2-Dichloroethane (not applicable at Outfall 019)	µg/L	--	0.5	--
	lbs/day ²	--	0.67	--
1,1-Dichloroethylene	µg/L	3.2	6.0	--
	lbs/day ²	4.3	8.0	--
Trichloroethylene	µg/L	--	5.0	--
	lbs/day ²	--	6.7	--
TCDD (TEQ)	µg/L	1.4E-08	2.8E-08	--
	lbs/day ²	1.9E-08	3.7E-08	--
2,4,6-Trichlorophenol	µg/L	6.5	13	--
	lbs/day ²	8.7	17	--
2,4-Dinitrotoluene	µg/L	9.1	18	--
	lbs/day ²	12	24	--
Alpha BHC	µg/L	0.01	0.03	--
	lbs/day ²	0.013	0.04	--
N-Nitrosodimethylamine	µg/L	8.1	16	--
	lbs/day ²	11	22	--
Pentachlorophenol	µg/L	8.2	16.5	--
	lbs/day ²	11	22	--
Bis(2-ethylhexyl) phthalate	µg/L	--	4.0	--
	lbs/day	--	5.3	--

Parameter	Units	Effluent Limitations		
		Average Monthly ¹⁴	Maximum Daily	Instantaneous Minimum/Maximum
<i>Non-Conventional Pollutants</i>				
Chloride	mg/L	--	150	--
	lbs/day	--	200,160	--
Acute toxicity	% survival	--	¹³	--
Chronic toxicity	TUc		1 ⁹	--
Chlorine, Total Residual	mg/L	--	0.1	--
	lbs/day	--	133	--
Ammonia – N	mg/L	1.96 ³	10.1 ⁴	--
	lbs/day ²	2,615	13,500	--
Nitrate - N	mg/L	--	8 ¹⁰	--
	lbs/day ²	--	10,700	--
Nitrite - N	mg/L	--	1 ¹⁰	--
	lbs/day ²	--	1,334	--
Nitrate +Nitrite - N	mg/L	--	8 ¹⁰	--
	lbs/day ²	--	10,700	--
Settleable Solids ¹	ml/L	0.1	0.3	--
Sulfate	mg/L	--	300	--
	lbs/day ²	--	400,320	--
Barium	mg/L	--	1.0	--
	lbs/day ²	--	1,330	--
Fluoride	mg/L	--	1.6	--
	lbs/day ²	--	2,135	--
Iron	mg/L	--	0.3	--
	lbs/day ²	--	400	--
Detergents (as MBAS)	mg/L	--	0.5	--
	lbs/day ²	--	667	--
Temperature	°F	--	--	86
Total Dissolved Solids	mg/L	--	950	--
	lbs/day ²	--	1,270,000	--
Perchlorate	µg/L	--	6.0	--
	lbs/day ²	--	8.0	--
Manganese	µg/L	--	50	--
	lbs/day ²	--	66.7	--
Radioactivity Gross Alpha	pCi/L	--	15	--
Gross Beta	pCi/L	--	50	--
Combined Radium -226 & Radium-228	pCi/L	--	5.0	--
Tritium	pCi/L	--	20,000	--

Parameter	Units	Effluent Limitations		
		Average Monthly ¹⁴	Maximum Daily	Instantaneous Minimum/Maximum
Strontium- 90	pCi/L	--	8.0	--

2. Final Effluent Limitations – Outfalls 003 - 010.

- a. The discharge of storm water only from the above referenced locations with constituents in excess of the following limits is prohibited.

Parameter	Units	Effluent Limitations	
		Maximum Daily	Instantaneous Minimum/ Maximum
<i>Conventional Pollutants</i>			
Oil and Grease	mg/L	15	--
	lbs/day ²	2,227	--
pH	s.u.	--	6.5/8.5
<i>Priority Pollutants</i>			
Antimony, Total Recoverable ⁵	µg/L	6.0	--
	lbs/day ²	0.89	--
Cadmium, Total Recoverable ⁵	µg/L	4.0/3.1 ^{7,11}	--
	lbs/day ²	0.59/0.46 ^{7,11}	--
Copper, Total Recoverable	µg/L	14	--
	lbs/day ²	2.1	--
Lead, Total Recoverable ⁵	µg/L	5.2	--
	lbs/day ²	0.77	--
Mercury, Total Recoverable ⁵	µg/L	0.13	--
	lbs/day ²	0.02	--
Nickel, Total Recoverable ⁵	µg/L	100	--
	lbs/day ²	14.9	--
Selenium, Total Recoverable ⁵	µg/L	5 ¹¹	--
	lbs/day ²	0.7	--
Thallium, Total Recoverable ⁵	µg/L	2.0	--
	lbs/day ²	0.3	--
Zinc, Total Recoverable ⁵	µg/L	159 ¹¹	--
	lbs/day ²	24	--
Cyanide, Total Recoverable	µg/L	9.5	--

Parameter	Units	Effluent Limitations	
		Maximum Daily	Instantaneous Minimum/ Maximum
	lbs/day ²	1.4	--
TCDD	µg/L	2.8E-08	--
	lbs/day ²	4.2E-09	--
<i>Non-Conventional Pollutants</i>			
Acute toxicity	% survival	1 ³	--
Chronic toxicity	TUc	1 ¹²	--
Chloride	mg/L	150	--
	lbs/day	22,268	--
Boron	mg/L	1.0	--
	lbs/day	148	--
Ammonia – N ¹¹	mg/L	10.1 ⁴	--
	lbs/day ²	15,000 ⁴	--
Nitrate – N	mg/L	8 ¹¹	--
	lbs/day ²	1,190 ¹¹	--
Nitrite - N	mg/L	1 ¹¹	--
	lbs/day ²	148 ¹¹	--
Nitrate +Nitrite - N	mg/L	8 ¹¹	--
	lbs/day ²	1,188 ¹¹	--
Nitrate +Nitrite - N	mg/L	10 ¹²	--
	lbs/day ²	1,485 ¹²	--
Sulfate	mg/L	250 ¹²	--
	lbs/day ²	37,113 ¹²	--
Sulfate	mg/L	300 ¹¹	--
	lbs/day ²	44,536 ¹¹	--
Fluoride	mg/L	1.6	--
	lbs/day ²	238	--
Perchlorate	µg/L	6.0	--
	lbs/day ²	0.89	--
Temperature	°F	--	86
Total Dissolved Solids	mg/L	850 ¹²	--
	lbs/day ²	126,184 ¹²	--
Total Dissolved Solids	mg/L	950 ¹¹	--
	lbs/day ²	141,029 ¹¹	--
Radioactivity			
Gross Alpha	pCi/L	15	--
Gross Beta	pCi/L	50	--
Combined Radium -226 & Radium-228	pCi/L	5.0	--
Tritium	pCi/L	20,000	--

Parameter	Units	Effluent Limitations	
		Maximum Daily	Instantaneous Minimum/ Maximum
Strontium-90	pCi/L	8.0	--

3. Benchmarks* – Outfalls 012 - 014

Parameter	Units	Effluent Limitations	
		Maximum Daily	Instantaneous Minimum/ Maximum
<i>Conventional Pollutants</i>			
Oil and Grease	mg/L	15	--
	lbs/day ²	0.5	--
pH	s.u.	--	6.5/8.5
<i>Priority Pollutants</i>			
Cadmium, Total Recoverable	µg/L	3.1	--
	lbs/day ²	0.0001	--
Copper, Total Recoverable	µg/L	14	--
	lbs/day ²	0.0004	--
Lead, Total Recoverable	µg/L	5.2	--
	lbs/day ²	0.0002	--
Mercury, Total Recoverable	µg/L	0.10	--
	lbs/day ²	0.000003	--
Selenium, total Recoverable	µg/L	5	--
	lbs/day ²	0.0002	--
Zinc, Total Recoverable	µg/L	159	--
	lbs/day ²	0.005	--
Naphthalene	µg/L	21	--
	lbs/day ²	0.0007	--
TCDD	µg/L	2.8E-08	--
	lbs/day ²	9.3E-12	--
<i>Non-Conventional Pollutants</i>			
Acute toxicity	% survival	13	--
Chloride	mg/L	150	--
	lbs/day	5.0	--
Total petroleum hydrocarbons	µg/L	100	--

Parameter	Units	Effluent Limitations	
		Maximum Daily	Instantaneous Minimum/ Maximum
Ethylene dibromide	lbs/day ²	0.003	--
	µg/L	50	--
	lbs/day ²	0.002	--
Tertiary butyl alcohol	µg/L	12	--
	lbs/day ²	0.0004	--
Ammonia – N	mg/L	10.1 ⁴	--
	lbs/day ²	0.34 ⁴	--
Nitrate - N	mg/L	8	--
	lbs/day ²	0.3	--
Nitrite - N	mg/L	1	--
	lbs/day ²	0.03	--
Nitrate +Nitrite - N	mg/L	8	--
	lbs/day ²	0.3	--
Settleable Solids	ml/L	0.3	--
Sulfate	mg/L	300	--
	lbs/day ²	10	--
Fluoride	mg/L	1.6	--
	lbs/day ²	0.5	--
1,4-Dioxane	µg/L	3	--
	lbs/day ²	0.0001	--
Perchlorate	µg/L	6.0	--
	lbs/day ²	0.0002	--
Temperature	°F	--	86
Total suspended solids	mg/L	45	--
	lbs/day ²	1.5	--
Total Dissolved Solids	mg/L	950	--
	lbs/day	31.7	--

- * A “benchmark” is a water quality based effluent limit or a performance based limit that is used to evaluate the performance of best management practices (BMPs) with regard to the removal of contaminants present in the discharge. In this permit, the benchmarks are established based on water quality based effluent limitations. Exceedance of a benchmark triggers an evaluation of the BMPs implemented at the site. The evaluation may determine that the BMPs require augmentation, upgrading, or replacement. If so, the Discharger must develop a plan to implement the required upgrades and report to the Regional Water Board staff within 60 days of the reported exceedance. The Discharger will continue monitoring as directed in the Monitoring and Reporting Program.
1. The effluent limitations for total suspended solids and settleable solids are not applicable for discharges during wet weather. During wet weather flow, a discharge event is greater than 0.1 inch of rainfall in a 24-hour period. No more than one sample per week need be obtained during extended periods of rainfall or the discharge of collected storm water. A storm event must be preceded by at least 72 hours of dry weather.
 2. The mass is calculated using the maximum permitted flow of 160 mgd for Outfalls 001 and 002. The flow used to calculate the mass for Outfalls 003 through 010 is 17.89 mgd. The flow used for Outfalls 012

through 014 was 0.004 mgd. If the recorded flow is different the mass should be recalculated using the equation: $\text{Mass (lbs/day)} = \text{Flow (mgd)} * 8.34 * \text{concentration (mg/L)}$.

3. Thirty day average at pH = 7.9 and 20°C, when hourly samples are collected and composited or only one grab sample is collected. Analysis for the temperature and pH of the receiving water at the same time as the discharge would provide data for a site specific determination of the ammonia limit using Attachment H to the WDR. Shall there be no receiving water present, the pH and temperature of the effluent at the monitoring location shall be determined and reported.
4. One hour average WLA at 7.9 pH and 20°C, applies if hourly samples are taken throughout the storm and each is analyzed. No single sample may exceed the 10.1 mg/L limit. Analysis for the temperature and pH of the receiving water at the same time as the discharge would provide data for a site specific determination of the ammonia limit using Attachment H to the WDR. Shall there be no receiving water present, the pH and temperature of the effluent at the end of pipe shall be determined and reported.
5. Concentrations correspond to a total hardness of 100 mg/L.
6. The Discharger has the option to meet the hexavalent chromium limitations with a total chromium analysis. However, if the total chromium level exceeds the hexavalent chromium limitation, it will be considered a violation unless an analysis has been made for hexavalent chromium in replicate sample and the result reported is within the hexavalent chromium limits.
7. Effluent limit applies only during wet weather discharges. The wet-weather targets apply to days when the maximum daily flow in the LA River is equal to or greater than 500 cubic feet per second (cfs).
8. Effluent limit applies only during dry weather discharges. The dry-weather targets apply to days when the maximum daily flow in the LA River is less than 500 cfs.
9. The chronic toxicity limit as defined in Item 5 below.
10. Average monthly limit from LA River Nitrogen Compounds and Related Effects TMDL. Since no daily maximum limit is provided, the average monthly waste load allocation becomes the daily maximum limit.
11. Limit applies to Outfall 008 only.
12. Limit applies to Outfalls 003-007, 009, and 010.
13. Acute Toxicity: There shall be no acute toxicity in the discharge. The acute toxicity of the effluent shall be such that:
 - (i) the average survival in the undiluted effluent for any three (3) consecutive 96-hour static or continuous flow bioassay tests shall be at least 90%, and
 - (ii) no single test producing less than 70 % survival. Compliance with the toxicity objectives will be determined by the method described in V.4 below
14. Outfall 019 only.

4. Acute Toxicity Limitation Requirements:

- a. The acute toxicity for all of the effluent discharges shall be such that: (i) the average survival in the undiluted effluent for any three (3) consecutive 96-hour static or continuous flow bioassay tests shall be at least 90%, and (ii) no single test producing less than 70 % survival.
- b. If either of the above requirements is not met, the Discharger shall conduct six additional tests over a six-week period. The discharger shall ensure that they receive results of a failing acute toxicity test within 24 hours of the close of the test and the additional tests shall begin within 3 business days of the receipt of the result. If the additional tests indicate compliance with acute toxicity limitation, the discharger may resume regular testing. However, if the results of any two of the six accelerated tests are less than 90% survival, then the Discharger shall begin a Toxicity Identification Evaluation (TIE). The TIE shall include all reasonable steps to identify the sources of toxicity. Once the sources are identified, the Discharger shall take all reasonable steps to reduce toxicity to meet the objective.

- c. If the initial test and any of the additional six acute toxicity bioassay test result in less than 70% survival, including the initial test, the Discharger shall immediately begin a TIE.
- d. The Discharger shall conduct acute toxicity monitoring as specified in Monitoring and Reporting Program No. 6027.

5. Chronic Toxicity Limitation and Requirements:

- a. This Order includes a chronic testing toxicity trigger defined as an exceedance of 1.0 TU_c in a critical life stage test for 100% effluent. (The monthly median for chronic toxicity of 100% effluent shall not exceed 1.0 TU_c in a critical life stage test.)
- b. If the chronic toxicity of the effluent exceeds 1.0 TU_c, the Discharger shall immediately implement an accelerated chronic toxicity testing according to MRP No. 6027. If the results of two of the six accelerated tests exceed 1.0 TU_c, the Discharger shall initiate a TIE and implement the Initial Investigation TRE Workplan. (see MRP No. 6027)
- c. The Discharger shall conduct chronic toxicity monitoring as specified in MRP No. 6027.
- d. The chronic toxicity of the effluent shall be expressed and reported in toxic units, where:

$$TU_c = \frac{100}{NOEC}$$

The No Observable Effect Concentration (NOEC) is expressed as the maximum percent effluent concentration that causes no observable effect on test organisms, as determined by the results of a critical life stage toxicity test.

6. Preparation of an Initial Investigation TRE Workplan

- a. The Discharger shall submit a detailed initial investigation Toxicity Reduction Evaluation (TRE) workplan to the Executive Officer of the Regional Water Board for approval within 90 days of the effective date of this permit. The Discharger shall use EPA manuals EPA/600/2-88/070 (industrial) or EPA/833B-99/002 (municipal) as guidance or current versions. At a minimum, the TRE workplan must contain the provisions in Attachment C. This workplan shall describe the steps the Discharger intends to follow if toxicity is detected, and should include, at a minimum:
- b. A description of the investigation and evaluation techniques that would be used to identify potential causes and sources of toxicity, effluent variability, and treatment system efficiency;

- c. A description of the facility's methods of maximizing in-house treatment efficiency and good housekeeping practices, and a list of all chemicals used in operation of the facility; and,
- d. If a toxicity identification evaluation (TIE) is necessary, an indication of the person who would conduct the TIEs (i.e., an in-house expert or an outside contractor) (See MRP. for guidance manuals).

B. Land Discharge Specifications

Not applicable

C. Reclamation Specifications

Not applicable

V. RECEIVING WATER LIMITATIONS

A. Surface Water Limitations

Receiving water limitations are based on water quality objectives contained in the Basin Plan and are a required part of this Order. The discharge shall not cause the following in Arroyo Simi or in Bell Creek:

- 1. The normal ambient pH to fall below 6.5 nor exceed 8.5 units nor vary from normal ambient pH levels by more than 0.5 units.
- 2. Surface water temperature to rise greater than 5°F above the natural temperature of the receiving waters at any time or place.
- 3. Water Contact Standards

State/Regional Water Board Water Contact Standards

In fresh water designated for water contact recreation (REC-I), the waste discharged shall not cause the following bacterial standards to be exceeded in the receiving water:

a. Geometric Mean Limits

E. coli density shall not exceed 126/100 ml.

Fecal coliform density shall not exceed 200/100 ml.

b. Single Sample Maximum (SSM)

E. coli density shall not exceed 235/100 ml.

Fecal coliform density shall not exceed 400/100 ml.

4. Depress the concentration of dissolved oxygen to fall below 5.0 mg/L anytime, and the median dissolved oxygen concentration for any three consecutive months shall not be less than 80 percent of the dissolved oxygen content at saturation.
5. Exceed total ammonia (as N) concentrations specified in the Regional Water Board Resolution No. 2002-011. Resolution No. 2002-011 revised the ammonia water quality objectives for inland surface waters characteristic of freshwater in the 1994 Basin Plan, to be consistent with the "1999 Update of Ambient Water Quality Criteria for Ammonia". Adopted on April 28, 2002, Resolution No. 2002-011 was approved by State Water Board, Office of Administrative Law (OAL) and USEPA on April 30, 2003, June 5, 2003, and June 19, 2003, respectively and is now in effect.
6. The presence of visible, floating, suspended or deposited macroscopic particulate matter or foam.
7. Oils, greases, waxes, or other materials in concentrations that result in a visible film or coating on the surface of the receiving water or on objects in the water.
8. Toxic or other deleterious substances in concentrations or quantities which cause deleterious effects on aquatic biota, wildlife, or waterfowl or render any of these unfit for human consumption either at levels created in the receiving waters or as a result of biological concentration.
9. Accumulation of bottom deposits or aquatic growths.
10. Dissolved sulfide concentration to exceed 0.1 mg/L
11. Violation of any applicable water quality standards for receiving waters adopted by the Regional Water Board or State Water Board. If more stringent applicable water quality standards are promulgated or approved pursuant to section 303 of the CWA, or amendments thereto, the Regional Water Board will revise or modify this Order in accordance with such standards.

B. Pesticides and PCBs

The discharge shall not cause the concentration of constituents in Arroyo Simi in the vicinity of the discharges, from Outfalls 003 through 007, 009, and 010, to exceed the following limits:

<u>Constituents</u>	<u>Units</u>	<u>Discharge</u>	<u>Limitations</u>
		<u>Monthly Average</u>	<u>Daily Maximum</u>
Chlorpyrifos	µg/L	---	0.02
Diazinon	µg/L	---	0.16
Chlordane	µg/L	---	0.001
4,4-DDD	µg/L	---	0.0014
4,4-DDE	µg/L	---	0.001
4,4-DDT	µg/L	---	0.001
Dieldrin	µg/L	---	0.0002
PCBs	µg/L	---	0.0003
Toxaphene	µg/L	---	0.0003

C. Final Ambient WLAs for Pollutants in Sediment for Storm Water Dischargers

Compliance is determined by evaluating the in-stream annual averages at the base of each subwatershed where the discharges are located.

The final WLAs must be achieved and become sediment limitations after the sampling indicates that the Discharger is able to comply with the final WLAs or at the end of the 20-year compliance schedule specified in the TMDL (March 24, 2026), whichever occurs first. In either event, the permit will be reopened at that time to include appropriate sediment limitations.

Constituents	Units	Discharge Limitations	
		Monthly Average	Daily Maximum
Chlordane	µg/g	--	0.0033
4,4-DDD	µg/g	--	0.002
4,4-DDE	µg/g	--	0.0014
4,4-DDT	µg/g	--	0.0003
Dieldrin	µg/g	--	0.0002

Constituents	Units	Discharge Limitations	
		Monthly Average	Daily Maximum
PCBs	µg/g	--	0.12
Toxaphene	µg/g	--	0.0006

D. Interim Ambient WLAs for Pollutants in Sediment for Storm Water Dischargers

The following sediment interim WLAs are effective as sediment limitations from the effective date of the permit through June 26, 2014.

<u>Constituents</u>	<u>Units</u>	<u>Discharge Limitations</u>	
		<u>Monthly Average</u>	<u>Daily Maximum</u>
Chlordane	µg/g	--	0.0033
4,4-DDD	µg/g	--	0.014
4,4-DDE	µg/g	--	0.17
4,4-DDT	µg/g	--	0.025
Dieldrin	µg/g	--	0.0011
PCBs	µg/g	--	25.7
Toxaphene	µg/g	--	0.23

The implementation schedule for the TMDL (Resolution No. R4-2005-0010) provides for interim sediment limitations through March 24, 2026 (twenty years from the effective date of the Basin Plan Amendment).

E. Groundwater Limitations

Not applicable

VI. PROVISIONS

A. Standard Provisions

1. Federal Standard Provisions. The Discharger shall comply with all Standard Provisions included in Attachment D of this Order.

2. Regional Water Board Standard Provisions. The Discharger shall comply with the following provisions:
 - a. With the exception of Outfalls 001 and 002 or 011 and 018, in the event that an effluent limitation set forth above for a pollutant other than a radioactive material is exceeded and the Discharger presents within 30 days of the date of discovery documentation that (i) discharges from a solid waste management unit (unit) regulated by DTSC are causing or contributing to the violation, and (ii) the Discharger was in compliance with all applicable requirements of DTSC permits and corrective action requirements for the unit, and (iii) modifications to DTSC's permit or corrective action requirements are necessary to consistently comply with this Order, then the Discharger, DTSC, and Regional Water Board will work cooperatively to develop a schedule that is as short as possible to take appropriate actions under the RCRA corrective action requirements or permits, as appropriate, to ensure compliance with this Order. This Order may be reopened and modified, in accordance with applicable laws and regulations, or a Time Schedule Order issued to incorporate appropriate interim limits while the appropriate actions are being taken under the RCRA corrective action requirements or permits.
 - b. This Order may be modified, revoked, reissued, or terminated in accordance with the provisions of sections 122.44, 122.62, 122.63, 122.64, 125.62 and 125.64. Causes for taking such actions include, but are not limited to: failure to comply with any condition of this Order; endangerment to human health or the environment resulting from the permitted activity; or acquisition of newly-obtained information which would have justified the application of different conditions if known at the time of Order adoption. The filing of a request by the Discharger for an Order modification, revocation, and issuance or termination, or a notification of planned changes or anticipated noncompliance does not stay any condition of this Order.
 - c. The Discharger must comply with the lawful requirements of municipalities, counties, drainage districts, and other local agencies regarding discharges of storm water to storm drain systems or other water courses under their jurisdiction; including applicable requirements in municipal storm water management program developed to comply with NPDES permits issued by the Regional Water Board to local agencies.
 - d. Discharges of wastes to any point other than specifically described in this Order and permit is prohibited and constitutes a violation thereof.
 - e. The Discharger shall comply with all applicable effluent limitations, national standards of performance, toxic effluent standards, and all federal regulations established pursuant to sections 301, 302, 303(d), 304, 306, 307, 316, 318, 405, and 423 of the Federal CWA and amendments thereto.
 - f. These requirements do not exempt the operator of the waste disposal facility from compliance with any other laws, regulations, or ordinances which may be

applicable; they do not legalize this waste disposal facility, and they leave unaffected any further restraints on the disposal of wastes at this site which may be contained in other statutes or required by other agencies.

- g. Oil or oily material, chemicals, refuse, or other pollutionable materials shall not be stored or deposited in areas where they may be picked up by rainfall and carried off of the property and/or discharged to surface waters. Any such spill of such materials shall be contained and removed immediately.
- h. A copy of these waste discharge specifications shall be maintained at the discharge facility so as to be available at all times to operating personnel.
- i. After notice and opportunity for a hearing, this Order may be terminated or modified for cause, including, but not limited to:
 - i. Violation of any term or condition contained in this Order;
 - ii. Obtaining this Order by misrepresentation, or failure to disclose all relevant facts;
 - iii. A change in any condition that requires either a temporary or permanent reduction or elimination of the authorized discharge.
- j. If there is any storage of hazardous or toxic materials or hydrocarbons at this facility and if the facility is not manned at all times, a 24-hour emergency response telephone number shall be prominently posted where it can easily be read from the outside.
- k. The Discharger shall notify the Regional Water Board not later than 120 days in advance of implementation of any plans to alter production capacity of the product line of the manufacturing, producing or processing facility by more than ten percent. Such notification shall include estimates of proposed production rate, the type of process, and projected effects on effluent quality. Notification shall include submittal of a new report of waste discharge appropriate filing fee.
- l. The Discharger shall file with the Regional Water Board a report of waste discharge at least 120 days before making any material change or proposed change in the character, location or volume of the discharge.
- m. All existing manufacturing, commercial, mining, and silvicultural dischargers must notify the Regional Water Board as soon as they know or have reason to believe that they have begun or expect to begin to use or manufacture intermediate or final product or byproduct of any toxic pollutant that was not reported on their application.
- n. In the event of any change in name, ownership, or control of these waste disposal facilities, the discharger shall notify this Regional Water Board of such

change and shall notify the succeeding owner or operator of the existence of this Order by letter, copy of which shall be forwarded to the Regional Water Board.

- o. The Water Code provides that any person who violates a waste discharge requirement or a provision of the Water Code is subject to civil penalties of up to \$5,000 per day, \$10,000 per day, or \$25,000 per day of violation, or when the violation involves the discharge of pollutants, is subject to civil penalties of up to \$10 per gallon per day or \$25 per gallon per day of violation; or some combination thereof, depending on the violation, or upon the combination of violations.

Violation of any of the provisions of the NPDES program or of any of the provisions of this Order may subject the violator to any of the penalties described herein, or any combination thereof, at the discretion of the prosecuting authority; except that only one kind of penalty may be applied for each kind of violation.

- p. The discharge of any product registered under the Federal Insecticide, Fungicide, and Rodenticide Act to any waste stream which may ultimately be released to waters of the United States, is prohibited unless specifically authorized elsewhere in this permit or another NPDES permit. This requirement is not applicable to products used for lawn and agricultural purposes.
- q. The discharge of any waste resulting from the combustion of toxic or hazardous wastes to any waste stream that ultimately discharges to waters of the United States is prohibited, unless specifically authorized elsewhere in this permit.
- r. The Discharger shall notify the Executive Officer in writing no later than 6 months prior to the planned discharge of any chemical, other than the products previously reported to the Executive Officer, which may be toxic to aquatic life. Such notification shall include:
 - i. Name and general composition of the chemical,
 - ii. Frequency of use,
 - iii. Quantities to be used,
 - iv. Proposed discharge concentrations, and
 - v. USEPA registration number, if applicable.
- s. Failure to comply with provisions or requirements of this Order, or violation of other applicable laws or regulations governing discharges from this facility, may subject the Discharger to administrative or civil liabilities, criminal penalties, and/or other enforcement remedies to ensure compliance. Additionally, certain violations may subject the Discharger to civil or criminal enforcement from appropriate local, state, or federal law enforcement entities.

- t. In the event the Discharger does not comply or will be unable to comply for any reason, with any prohibition, maximum daily effluent limitation, monthly average effluent limitation, instantaneous minimum, or instantaneous maximum, or receiving water limitation of this Order, the Discharger shall notify the Regional Water Board by telephone (213) 576-6600 within 24 hours of having knowledge of such noncompliance, and shall confirm this notification in writing within five days, unless the Regional Water Board waives confirmation. The written notification shall state the nature, time, duration, and cause of noncompliance, and shall describe the measures being taken to remedy the current noncompliance and, prevent recurrence including, where applicable, a schedule of implementation. Other noncompliance requires written notification as above at the time of the normal monitoring report.
- u. Prior to making any change in the point of discharge, place of use, or purpose of use of treated wastewater that results in a decrease of flow in any portion of a watercourse, the Discharger must file a petition with the State Water Board, Division of Water Rights, and receive approval for such a change. (Water Code § 1211)

B. Monitoring and Reporting Program (MRP) Requirements

The Discharger shall comply with the MRP, and future revisions thereto, in Attachment E of this Order.

C. Special Provisions

1. Reopener Provisions

- a. This Order may be reopened and modified, in accordance with SIP Section 2.2.2.A, to incorporate new limits based on future reasonable potential analysis to be conducted, upon completion of the collection of additional data by the Discharger. Notwithstanding the foregoing, in the event that reasonable potential analyses indicate that a pollutant has reasonable potential the Regional Water Board staff shall bring an appropriate modification to the Regional Water Board, at the next practicable Board Meeting.
- b. If more stringent applicable water quality standards are promulgated or approved pursuant to Section 303 of the Federal CWA, and amendments thereto, the Regional Water Board will revise and modify this Order in accordance with such more stringent standards.
- c. This Order may be reopened and modified, in accordance with the provisions set forth in 40 CFR Parts 122 and 124, to include requirements for the implementation of the watershed management approach or to include new MLs.
- d. This Order may be reopened and modified to revise effluent limitations as a result of future Basin Plan Amendments, such as an update of an objective or the adoption of a TMDL for the Los Angeles River and tributaries thereto or to Arroyo Simi, a tributary to Calleguas Creek.

- e. This Order may be reopened and modified to consider incorporation of a site specific or regional design storm (based on the evaluation of the results of the Design Storm Project) and subsequent policy considerations.
- f. This Order may be reopened for modification, or revocation and reissuance, as a result of the detection of a reportable priority pollutant generated by special conditions included in this Order. These special conditions may be, but are not limited to, fish tissue sampling, whole effluent toxicity, monitoring requirements on internal waste stream(s), and monitoring for surrogate parameters. Additional requirements may be included in this Order as a result of the special condition monitoring data. Special Studies, Technical Reports and Additional Monitoring Requirements.
- g. This Order may be reopened and modified, to revise the toxicity language once that language becomes standardized.
- h. In accordance with Provision VII.2.a, this Order may be reopened and modified to incorporate interim limits, to the extent authorized by law, while DTSC revises and reissues updated RCRA corrective action requirements or permits, as appropriate, to ensure compliance with this Order.
- i. This Order may also be reopened and modified, revoked, and reissued or terminated in accordance with the provisions of 40 CFR sections 122.44, 122.62 to 122.64, 125.62, and 125.64. Causes for taking such actions include, but are not limited to, failure to comply with any condition of this order and permit, endangerment to human health or the environment resulting from the permitted activity.

2. **Special Studies, Technical Reports and Additional Monitoring Requirements**

- a. **Initial Investigation Toxicity Reduction Evaluation (TRE) Workplan.** The Discharger shall submit to the Regional Water Board an Initial Investigation Toxicity Reduction Evaluation (TRE) workplan (1-2 pages) **within 90 days** of the effective date of this permit. This plan shall describe the steps the permittee intends to follow in the event that toxicity is detected, and should include at a minimum:
 - i. A description of the investigation and evaluation techniques that will be used to identify potential causes/sources of toxicity, effluent variability, and treatment system efficiency;
 - ii. A description of the facility's method of maximizing in-house treatment efficiency and good housekeeping practices, and a list of all chemicals used in operation of the facility;
 - iii. If a Toxicity Identification Evaluation (TIE) is necessary, an indication of the person who would conduct the TIEs (i.e., an in-house expert or an outside contractor) (Section V of the MRP, Attachment E provides references for the guidance manuals that should be used for performing TIEs).

3. Storm Water Pollution Prevention, Best Management Practices, and Spill Contingency Plan

- a. The Discharger shall submit within 90 days of the effective date of this Order:
 - i. An updated Storm Water Pollution Prevention Plan (SWPPP) that describes site-specific management practices for minimizing contamination of storm water runoff and for preventing contaminated storm water runoff from being discharged directly to waters of the State. The SWPPP shall be developed in accordance with the requirements in Attachment I.
 - ii. An updated Best Management Practices (BMPs) Plan that includes site-specific plans and procedures implemented to prevent hazardous waste/material from being discharged to waters of the State. The BMPs shall be consistent with the general guidance contained in the USEPA Guidance Manual for Developing Best Management Practices (BMPs) (EPA 833-B-93-004) and any applicable advanced technologies. The SWPPP and the BMP plans shall be implemented 30 days after submittal to the Regional Water Board for approval. If the Regional Water Board does not provide specific comments on the plans submitted they are to be implemented as proposed.

With input from the Expert Panel, the Discharger shall submit a workplan that describes and prioritizes BMPs, including measurable milestones and implementing Interim Source Removal Action (ISRA) and Engineered Natural Treatment Systems (ENTS) that will resolve exceedances from Outfalls 008 and 009. This workplan will describe the siting and phasing of BMPs.

- iii. A Spill Contingency Plan (or substituted with an updated version of the Dischargers Spill Prevention Control and Countermeasure Plan).

Each plan shall cover all areas of the Facility and shall include an updated drainage map of the Facility. The Discharger shall identify on a map of appropriate scale the areas that contribute runoff to the permitted discharge point; describe the activities in each area and the potential for contamination of storm water runoff from historical contamination and the discharge of hazardous waste/material; and address the feasibility of containment and/or treatment of storm. The plans must be reviewed and updated annually at the same time. Updated information shall be submitted within 30 days of revision.

- iv. Pollutant Minimization Program:

The Discharger shall develop a PMP to maintain effluent concentrations of OC Pesticides and PCBs at or below the effluent limitations specified in Receiving Water Limitations and Interim Ambient Mass of Pollutants in Sediment for Storm Water Dischargers specified in this Order. The PMP shall include the following:

- a. Annual review and monitoring of the receiving water, sediment in the receiving water, and the effluent for OC Pesticides and PCBs;
- b. Submittal of a control strategy designed to proceed toward the goal of maintaining effluent concentrations at or below the effluent limitation;
- c. Implementation of appropriate cost-effective control measures consistent with the control strategy;
- d. An annual status report that shall be sent to the Regional Water Board at the same time the annual summary report is submitted in accordance with section I.B of the MRP, and include:
 1. All PMP monitoring results for the previous year;
 2. A list of potential sources of OC Pesticides and PCBs;
 3. A summary of all actions undertaken pursuant to the control strategy;
 4. A description of actions to be taken in the following year.
- v. Compliance Plan.

The interim sediment limitations stipulated in section VI.C. of this Order for OC Pesticides and PCBs in sediment shall be in effect until April 10, 2014. The data collected will be evaluated and the ability of the Discharger to meet the final effluent limitations included in the Calleguas Creek OC Pesticides and PCBs TMDL evaluated. The TMDL includes provisions for the compliance schedule to be effective until March 24, 2026. Thereafter, the Discharger shall comply with the limitations specified for the OC Pesticides and PCBs in section VI.C of this Order.

The Discharger shall update the Compliance Plan submitted to the Regional Water Board which identified the measures taken to reduce the concentrations of OC Pesticides and PCBs in sediment at the base of the subwatershed discharging to Arroyo Simi. This plan must evaluate options to achieve compliance with final sediment limitations.

The Discharger shall submit annual reports to describe the progress of studies and or actions undertaken to reduce the OC Pesticides and PCBs in the effluent and the sediment, and to achieve compliance with the limitations in this Order by the deadline specified above. The Regional Water Board shall receive the annual progress reports at the same time as the annual summary report is due.

D. Construction, Operation and Maintenance Specifications

The Discharger shall at all times properly operate and maintain all facilities and systems installed or used to achieve compliance with this Order.

E. Special Provisions for Municipal Facilities (POTWs Only)

Not Applicable

F. Other Special Provisions

Pursuant to the requirements of 40 CFR 122.42(a), the Discharger must notify the Board as soon as it knows, or has reason to believe that it has begun or expected to being, to use or manufacture a toxic pollutant not reported in the permit application, or (2) a discharge of toxic pollutant not limited by this Order has occurred, or will occur, in concentrations that exceed the specified limitations in 40 CFR 122.42 (a).

VII. COMPLIANCE DETERMINATION

Compliance with the effluent limitations contained in section IV of this Order will be determined as specified below:

A. Single Constituent Effluent Limitation.

If the concentration of the pollutant in the monitoring sample is greater than the effluent limitation and greater than or equal to the reported Minimum Level (see Reporting Requirement I.G. of the MRP), then the Discharger is out of compliance.

B. Effluent Limitations Expressed as a Sum of Several Constituents.

If the sum of the individual pollutant concentrations is greater than the effluent limitation, then the Discharger is out of compliance. In calculating the sum of the concentrations of a group of pollutants, consider constituents reported as ND or DNQ to have concentrations equal to zero, provided that the applicable ML is used.

C. Multiple Sample Data.

When determining compliance with an AMEL or MDEL for priority pollutants and more than one sample result is available, the Discharger shall compute the arithmetic mean unless the data set contains one or more reported determinations of "Detected, but Not Quantified" (DNQ) or "Not Detected" (ND). In those cases, the Discharger shall compute the median in place of the arithmetic mean in accordance with the following procedure:

1. The data set shall be ranked from low to high, ranking the reported ND determinations lowest, DNQ determinations next, followed by quantified values (if any). The order of the individual ND or DNQ determinations is unimportant.
2. The median value of the data set shall be determined. If the data set has an odd number of data points, then the median is the middle value. If the data set has an even number of data points, then the median is the average of the two values around the middle unless one or both of the points are ND or DNQ, in which case the median value shall be the lower of the two data points where DNQ is lower than a value and ND is lower than DNQ.

D. Average Monthly Effluent Limitation (AMEL).

If the average (or when applicable, the median determined by subsection E above for multiple sample data) of daily discharges over a calendar month exceeds the AMEL for a given parameter, this will represent a single violation, though the Discharger will be considered out of compliance for each day of that month for that parameter (e.g., resulting in 31 days of non-compliance in a 31-day month). If only a single sample is taken during the calendar month and the analytical result for that sample exceeds the AMEL, the Discharger will be considered out of compliance for that calendar month. For any one calendar month during which no sample (daily discharge) is taken, no compliance determination can be made for that calendar month.

In determining compliance with the AMEL, the following provisions shall also apply to all constituents:

1. If the analytical result of a single sample, monitored monthly, quarterly, semiannually, or annually, does not exceed the AMEL for that constituent, the Discharger has demonstrated compliance with the AMEL for that month;
2. If the analytical result of a single sample, monitored monthly, quarterly, semiannually, or annually, exceeds the AMEL for any constituent, the Discharger shall collect four additional samples at approximately equal intervals during the month. All five analytical results shall be reported in the monitoring report for that month, or 45 days after results for the additional samples were received, whichever is later.

When all sample results are greater than or equal to the reported Minimum Level (see Reporting Requirement I.G. of the MRP), the numerical average of the analytical results of these five samples will be used for compliance determination.

When one or more sample results are reported as “Not-Detected (ND)” or “Detected, but Not Quantified (DNQ)” (see Reporting Requirement I.G. of the MRP), the median value of these four samples shall be used for compliance determination. If one or both of the middle values is ND or DNQ, the median shall be the lower of the two middle values.

3. In the event of noncompliance with an AMEL, the sampling frequency for that constituent shall be increased to weekly and shall continue at this level until compliance with the AMEL has been demonstrated.
4. If only one sample was obtained for the month or more than a monthly period and the result exceeds the AMEL, then the Discharger is in violation of the AMEL.

E. Maximum Daily Effluent Limitations (MDEL).

If a daily discharge exceeds the MDEL for a given parameter, an alleged violation will be flagged and the discharger will be considered out of compliance for that parameter

for that 1 day only within the reporting period. For any 1 day during which no sample is taken, no compliance determination can be made for that day.

F. Instantaneous Minimum Effluent Limitation.

If the analytical result of a single grab sample is lower than the instantaneous minimum effluent limitation for a parameter, a violation will be flagged and the discharger will be considered out of compliance for that parameter for that single sample. Non-compliance for each sample will be considered separately (e.g., the results of two grab samples taken within a calendar day that both are lower than the instantaneous minimum effluent limitation would result in two instances of non-compliance with the instantaneous minimum effluent limitation).

G. Instantaneous Maximum Effluent Limitation.

If the analytical result of a single grab sample is higher than the instantaneous maximum effluent limitation for a parameter, a violation will be flagged and the discharger will be considered out of compliance for that parameter for that single sample. Non-compliance for each sample will be considered separately (e.g., the results of two grab samples taken within a calendar day that both exceed the instantaneous maximum effluent limitation would result in two instances of non-compliance with the instantaneous maximum effluent limitation).

H. Compliance with the pH Limitation.

If the receiving water pH, exceeds 8.5 pH units as a result of

- a. high pH in the storm water, or
- b. elevated pH in the receiving water upstream of the discharge

then the exceedance shall not be considered a violation.

I. Compliance with the Temperature Limitation.

If the receiving water temperature downstream of the discharge, exceeds 86°F as a result of:

- a. high temperature in the ambient air, or
- b. elevated temperature in the receiving water upstream of the discharge,

then the exceedance shall not be considered a violation.

J. Benchmarks and Receiving Water Limitations.

A “benchmark” is a water quality based effluent limit or a performance based limit that is used to evaluate the performance of best management practices (BMPs) with regard to the removal of contaminants present in the discharge. In this permit, the benchmarks are established based on water quality based effluent limitations. Exceedance of a benchmark triggers an evaluation of the BMPs implemented at the site. The evaluation may determine that the BMPs require augmentation, upgrading, or replacement. If so,

the Discharger must develop a plan to implement the required upgrades and report to the Regional Water Board staff within 60 days of the reported exceedance. The Discharger will continue monitoring as directed in the Monitoring and Reporting Program and the Basin Management Practices Compliance Plan.

The Discharger shall comply with benchmarks and receiving water limitations through timely implementation of control measures and other actions to reduce pollutants in the discharges in accordance with the BMP plan and its components and other requirements of this Order including any modifications. The BMP plan and its components shall be designed to achieve compliance with receiving water limitations. If exceedances of Water Quality Objectives or Water Quality Standards (collectively, Water Quality Standards) persist, notwithstanding implementation of the BMP and its components and other requirements of this permit, the Discharger shall assure compliance with discharge prohibitions and receiving water limitations by complying with the following procedure:

1. Upon a determination by either the Permittee or the Regional Water Board that discharges are causing or contributing to an exceedance of an applicable Water Quality Standard, the Discharger shall within 24 hours notify and thereafter submit a revised BMP compliance report (as described in the Monitoring and Reporting Program) to the Regional Water Board that describes the BMPs that are currently being implemented and additional BMPs that will be implemented to prevent or reduce any pollutants that are causing or contributing to the exceedance of Water Quality Standards. This BMP Compliance Report is due to the Regional Water Board 60 days after the reported exceedance of a benchmark. The BMP Compliance Report shall include an implementation schedule along with descriptions and proposed installation locations of the upgrades or new BMPs. The Executive Officer at the Regional Water Board may require modifications to the BMP Compliance Report.
2. Submit any modifications to the BMP Compliance Report required by the Regional Water Board within 30 days of notification.
3. Within 30 days following the approval of the BMP Compliance Report, the Discharger shall revise the BMP Plan and its component and monitoring program to incorporate the approved modifications that have been and will be implemented; and implementation schedule, and any additional monitoring required.
4. Implement the revised BMP plan and its components and monitoring program according to the approved schedule.
5. So long as the Discharger has complied with the procedures set forth above and is implementing the revised BMP plan and its component, the Discharger does not have to repeat the same procedure for continuing or recurring exceedances of the same effluent limitations or receiving water limitations unless directed by the Regional Water Board to develop additional BMPs.

K. Mass Emission Rates

In calculating mass emission rates from the monthly average concentrations, use one half of the method detection limit for “not Detected” (ND) and the estimated concentration for “Detected, but Not Quantified” (DNQ) for the calculation of the monthly average concentration. To be consistent, if all pollutants belonging to the same group are reported as ND or DNQ, the sum of the individual pollutant concentrations should be considered as zero for the calculation of the monthly average concentrations.

L. Compliance with Sediment Effluent Limitations

Compliance with sediment effluent concentrations will be determined by calculating the in-stream annual average at the base of each subwatershed where the discharges are located. The Boeing SSFL discharge is located in Arroyo Simi and the sediment concentration at Arroyo Simi East of Hitch Boulevard or at Simi Valley Water Quality Control Plant should not exceed the interim effluent limitations. Since the facility is located near the top of the watershed, the Discharger collects samples closer to the facility, in Frontier Park. The data collected in this area will provide information regarding the contaminant concentrations in sediment in the upper watershed, and in the area that may be impacted by discharges from the facility.

ATTACHMENT A – DEFINITIONS

Arithmetic Mean (μ)

Also called the average, is the sum of measured values divided by the number of samples. For ambient water concentrations, the arithmetic mean is calculated as follows:

Arithmetic mean = $\mu = \Sigma x / n$ where: Σx is the sum of the measured ambient water concentrations, and n is the number of samples.

Average Monthly Effluent Limitation (AMEL)

The highest allowable average of daily discharges over a calendar month, calculated as the sum of all daily discharges measured during a calendar month divided by the number of daily discharges measured during that month.

Average Weekly Effluent Limitation (AWEL)

The highest allowable average of daily discharges over a calendar week (Sunday through Saturday), calculated as the sum of all daily discharges measured during a calendar week divided by the number of daily discharges measured during that week.

Benchmark

A “benchmark” is a water quality based effluent limit or a performance based limit that is used to evaluate the performance of best management practices (BMPs) with regard to the removal of contaminants present in the discharge. In this permit, the benchmarks are established based on water quality based effluent limitations. Exceedance of a benchmark triggers an evaluation of the BMPs implemented at the site. The evaluation may determine that the BMPs require augmentation, upgrading, or replacement. If so, the Discharger must develop a plan to implement the required upgrades and report to the Regional Water Board staff within 60 days of the reported exceedance. The Discharger will continue monitoring as directed in the Monitoring and Reporting Program.

Bioaccumulative

Those substances taken up by an organism from its surrounding medium through gill membranes, epithelial tissue, or from food and subsequently concentrated and retained in the body of the organism.

Carcinogenic

Pollutants are substances that are known to cause cancer in living organisms.

Coefficient of Variation (CV)

CV is a measure of the data variability and is calculated as the estimated standard deviation divided by the arithmetic mean of the observed values.

Daily Discharge

Daily Discharge is defined as either: (1) the total mass of the constituent discharged over the calendar day (12:00 am through 11:59 pm) or any 24-hour period that reasonably represents a calendar day for purposes of sampling (as specified in the permit), for a constituent with limitations expressed in units of mass or; (2) the unweighted arithmetic mean measurement of

the constituent over the day for a constituent with limitations expressed in other units of measurement (e.g., concentration).

The daily discharge may be determined by the analytical results of a composite sample taken over the course of one day (a calendar day or other 24-hour period defined as a day) or by the arithmetic mean of analytical results from one or more grab samples taken over the course of the day.

For composite sampling, if 1 day is defined as a 24-hour period other than a calendar day, the analytical result for the 24-hour period will be considered as the result for the calendar day in which the 24-hour period ends.

Detected, but Not Quantified (DNQ)

DNQ are those sample results less than the RL, but greater than or equal to the laboratory's MDL.

Dilution Credit

Dilution Credit is the amount of dilution granted to a discharge in the calculation of a water quality-based effluent limitation, based on the allowance of a specified mixing zone. It is calculated from the dilution ratio or determined through conducting a mixing zone study or modeling of the discharge and receiving water.

Effluent Concentration Allowance (ECA)

ECA is a value derived from the water quality criterion/objective, dilution credit, and ambient background concentration that is used, in conjunction with the coefficient of variation for the effluent monitoring data, to calculate a long-term average (LTA) discharge concentration. The ECA has the same meaning as waste load allocation (WLA) as used in USEPA guidance (Technical Support Document For Water Quality-based Toxics Control, March 1991, second printing, EPA/505/2-90-001).

Enclosed Bays

Enclosed Bays means indentations along the coast that enclose an area of oceanic water within distinct headlands or harbor works. Enclosed bays include all bays where the narrowest distance between the headlands or outermost harbor works is less than 75 percent of the greatest dimension of the enclosed portion of the bay. Enclosed bays include, but are not limited to, Humboldt Bay, Bodega Harbor, Tomales Bay, Drake's Estero, San Francisco Bay, Morro Bay, Los Angeles-Long Beach Harbor, Upper and Lower Newport Bay, Mission Bay, and San Diego Bay. Enclosed bays do not include inland surface waters or ocean waters.

Estimated Chemical Concentration

The estimated chemical concentration that results from the confirmed detection of the substance by the analytical method below the ML value.

Estuaries

Estuaries means waters, including coastal lagoons, located at the mouths of streams that serve as areas of mixing for fresh and ocean waters. Coastal lagoons and mouths of streams that are temporarily separated from the ocean by sandbars shall be considered estuaries. Estuarine waters shall be considered to extend from a bay or the open ocean to a point

upstream where there is no significant mixing of fresh water and seawater. Estuarine waters included, but are not limited to, the Sacramento-San Joaquin Delta, as defined in Water Code section 12220, Suisun Bay, Carquinez Strait downstream to the Carquinez Bridge, and appropriate areas of the Smith, Mad, Eel, Noyo, Russian, Klamath, San Diego, and Otay rivers. Estuaries do not include inland surface waters or ocean waters.

Inland Surface Waters

All surface waters of the State that do not include the ocean, enclosed bays, or estuaries.

Instantaneous Maximum Effluent Limitation

The highest allowable value for any single grab sample or aliquot (i.e., each grab sample or aliquot is independently compared to the instantaneous maximum limitation).

Instantaneous Minimum Effluent Limitation

The lowest allowable value for any single grab sample or aliquot (i.e., each grab sample or aliquot is independently compared to the instantaneous minimum limitation).

Maximum Daily Effluent Limitation (MDEL)

The highest allowable daily discharge of a pollutant, over a calendar day (or 24-hour period). For pollutants with limitations expressed in units of mass, the daily discharge is calculated as the total mass of the pollutant discharged over the day. For pollutants with limitations expressed in other units of measurement, the daily discharge is calculated as the arithmetic mean measurement of the pollutant over the day.

Median

The middle measurement in a set of data. The median of a set of data is found by first arranging the measurements in order of magnitude (either increasing or decreasing order). If the number of measurements (n) is odd, then the median = $X_{(n+1)/2}$. If n is even, then the median = $(X_{n/2} + X_{(n/2)+1})/2$ (i.e., the midpoint between the $n/2$ and $n/2+1$).

Method Detection Limit (MDL)

MDL is the minimum concentration of a substance that can be measured and reported with 99 percent confidence that the analyte concentration is greater than zero, as defined in title 40 of the Code of Federal Regulations, Part 136, Attachment B, revised as of July 3, 1999.

Minimum Level (ML)

ML is the concentration at which the entire analytical system must give a recognizable signal and acceptable calibration point. The ML is the concentration in a sample that is equivalent to the concentration of the lowest calibration standard analyzed by a specific analytical procedure, assuming that all the method specified sample weights, volumes, and processing steps have been followed.

Mixing Zone

Mixing Zone is a limited volume of receiving water that is allocated for mixing with a wastewater discharge where water quality criteria can be exceeded without causing adverse effects to the overall water body.

Not Detected (ND)

Sample results which are less than the laboratory's MDL.

Ocean Waters

The territorial marine waters of the State as defined by California law to the extent these waters are outside of enclosed bays, estuaries, and coastal lagoons. Discharges to ocean waters are regulated in accordance with the State Water Board's California Ocean Plan.

Persistent Pollutants

Persistent pollutants are substances for which degradation or decomposition in the environment is nonexistent or very slow.

Pollutant Minimization Program (PMP)

PMP means waste minimization and pollution prevention actions that include, but are not limited to, product substitution, waste stream recycling, alternative waste management methods, and education of the public and businesses. The goal of the PMP shall be to reduce all potential sources of a priority pollutant(s) through pollutant minimization (control) strategies, including pollution prevention measures as appropriate, to maintain the effluent concentration at or below the water quality-based effluent limitation. Pollution prevention measures may be particularly appropriate for persistent bioaccumulative priority pollutants where there is evidence that beneficial uses are being impacted. The Regional Water Board may consider cost effectiveness when establishing the requirements of a PMP. The completion and implementation of a Pollution Prevention Plan, if required pursuant to Water Code section 13263.3(d), shall be considered to fulfill the PMP requirements.

Pollution Prevention

Pollution Prevention means any action that causes a net reduction in the use or generation of a hazardous substance or other pollutant that is discharged into water and includes, but is not limited to, input change, operational improvement, production process change, and product reformulation (as defined in Water Code section 13263.3). Pollution prevention does not include actions that merely shift a pollutant in wastewater from one environmental medium to another environmental medium, unless clear environmental benefits of such an approach are identified to the satisfaction of the State or Regional Water Board.

Reporting Level (RL)

RL is the ML (and its associated analytical method) chosen by the Discharger for reporting and compliance determination from the MLs included in this Order. The MLs included in this Order correspond to approved analytical methods for reporting a sample result that are selected by the Regional Water Board either from Appendix 4 of the SIP in accordance with section 2.4.2 of the SIP or established in accordance with section 2.4.3 of the SIP. The ML is based on the proper application of method-based analytical procedures for sample preparation and the absence of any matrix interferences. Other factors may be applied to the ML depending on the specific sample preparation steps employed. For example, the treatment typically applied in cases where there are matrix-effects is to dilute the sample or sample aliquot by a factor of ten. In such cases, this additional factor must be applied to the ML in the computation of the RL.

Satellite Collection System

The portion, if any, of a sanitary sewer system owned or operated by a different public agency than the agency that owns and operates the wastewater treatment facility that a sanitary sewer system is tributary to.

Source of Drinking Water

Any water designated as municipal or domestic supply (MUN) in a Regional Water Board Basin Plan.

Standard Deviation (σ)

Standard Deviation is a measure of variability that is calculated as follows:

$$\sigma = (\sum[(x - \mu)^2]/(n - 1))^{0.5}$$

where:

x is the observed value;

μ is the arithmetic mean of the observed values; and

n is the number of samples.

Toxicity Reduction Evaluation (TRE)

TRE is a study conducted in a step-wise process designed to identify the causative agents of effluent or ambient toxicity, isolate the sources of toxicity, evaluate the effectiveness of toxicity control options, and then confirm the reduction in toxicity. The first steps of the TRE consist of the collection of data relevant to the toxicity, including additional toxicity testing, and an evaluation of facility operations and maintenance practices, and best management practices. A Toxicity Identification Evaluation (TIE) may be required as part of the TRE, if appropriate. (A TIE is a set of procedures to identify the specific chemical(s) responsible for toxicity. These procedures are performed in three phases (characterization, identification, and confirmation) using aquatic organism toxicity tests.)

ACRONYMS AND ABBREVIATIONS

AMEL	Average Monthly Effluent Limitation
B	Background Concentration
BAT	Best Available Technology Economically Achievable
Basin Plan	<i>Water Quality Control Plan for the Coastal Watersheds of Los Angeles and Ventura Counties</i>
BCT	Best Conventional Pollutant Control Technology
BMP	Best Management Practices
BMPPP	Best Management Practices Plan
BPJ	Best Professional Judgment
BOD	Biochemical Oxygen Demand 5-day @ 20 °C
BPT	Best Practicable Treatment Control Technology
C	Water Quality Objective
CCR	California Code of Regulations
CEQA	California Environmental Quality Act
CFR	Code of Federal Regulations
CTR	California Toxics Rule
CV	Coefficient of Variation
CWA	Clean Water Act
CWC	California Water Code
Discharger	The Boeing Company
DMR	Discharge Monitoring Report
DNQ	Detected But Not Quantified
ELAP	California Department of Health Services Environmental Laboratory Accreditation Program
ELG	Effluent Limitations, Guidelines and Standards
Facility	Santa Susana Field Laboratory
gpd	gallons per day
IC	Inhibition Coefficient
IC ₁₅	Concentration at which the organism is 15% inhibited
IC ₂₅	Concentration at which the organism is 25% inhibited
IC ₄₀	Concentration at which the organism is 40% inhibited
IC ₅₀	Concentration at which the organism is 50% inhibited
LA	Load Allocations
LOEC	Lowest Observed Effect Concentration
µg/L	micrograms per Liter
mg/L	milligrams per Liter
MDEL	Maximum Daily Effluent Limitation
MEC	Maximum Effluent Concentration
MGD	Million Gallons Per Day
ML	Minimum Level
MRP	Monitoring and Reporting Program
ND	Not Detected
NOEC	No Observable Effect Concentration
NPDES	National Pollutant Discharge Elimination System
NSPS	New Source Performance Standards

NTR	National Toxics Rule
OAL	Office of Administrative Law
PMEL	Proposed Maximum Daily Effluent Limitation
PMP	Pollutant Minimization Plan
POTW	Publicly Owned Treatment Works
QA	Quality Assurance
QA/QC	Quality Assurance/Quality Control
Ocean Plan	<i>Water Quality Control Plan for Ocean Waters of California</i>
Regional Water Board	California Regional Water Quality Control Board, Los Angeles Region
RPA	Reasonable Potential Analysis
SCP	Spill Contingency Plan
SIP	State Implementation Policy (<i>Policy for Implementation of Toxics Standards for Inland Surface Waters, Enclosed Bays, and Estuaries of California</i>)
SMR	Self Monitoring Reports
State Water Board	California State Water Resources Control Board
SWPPP	Storm Water Pollution Prevention Plan
TAC	Test Acceptability Criteria
Thermal Plan	<i>Water Quality Control Plan for Control of Temperature in the Coastal and Interstate Water and Enclosed Bays and Estuaries of California</i>
TIE	Toxicity Identification Evaluation
TMDL	Total Maximum Daily Load
TOC	Total Organic Carbon
TRE	Toxicity Reduction Evaluation
TSD	Technical Support Document
TSS	Total Suspended Solid
TU _c	Chronic Toxicity Unit
USEPA	United States Environmental Protection Agency
WDR	Waste Discharge Requirements
WET	Whole Effluent Toxicity
WLA	Waste Load Allocations
WQBELs	Water Quality-Based Effluent Limitations
WQS	Water Quality Standards
%	Percent

ATTACHMENT B – SSFL LOCATION MAP

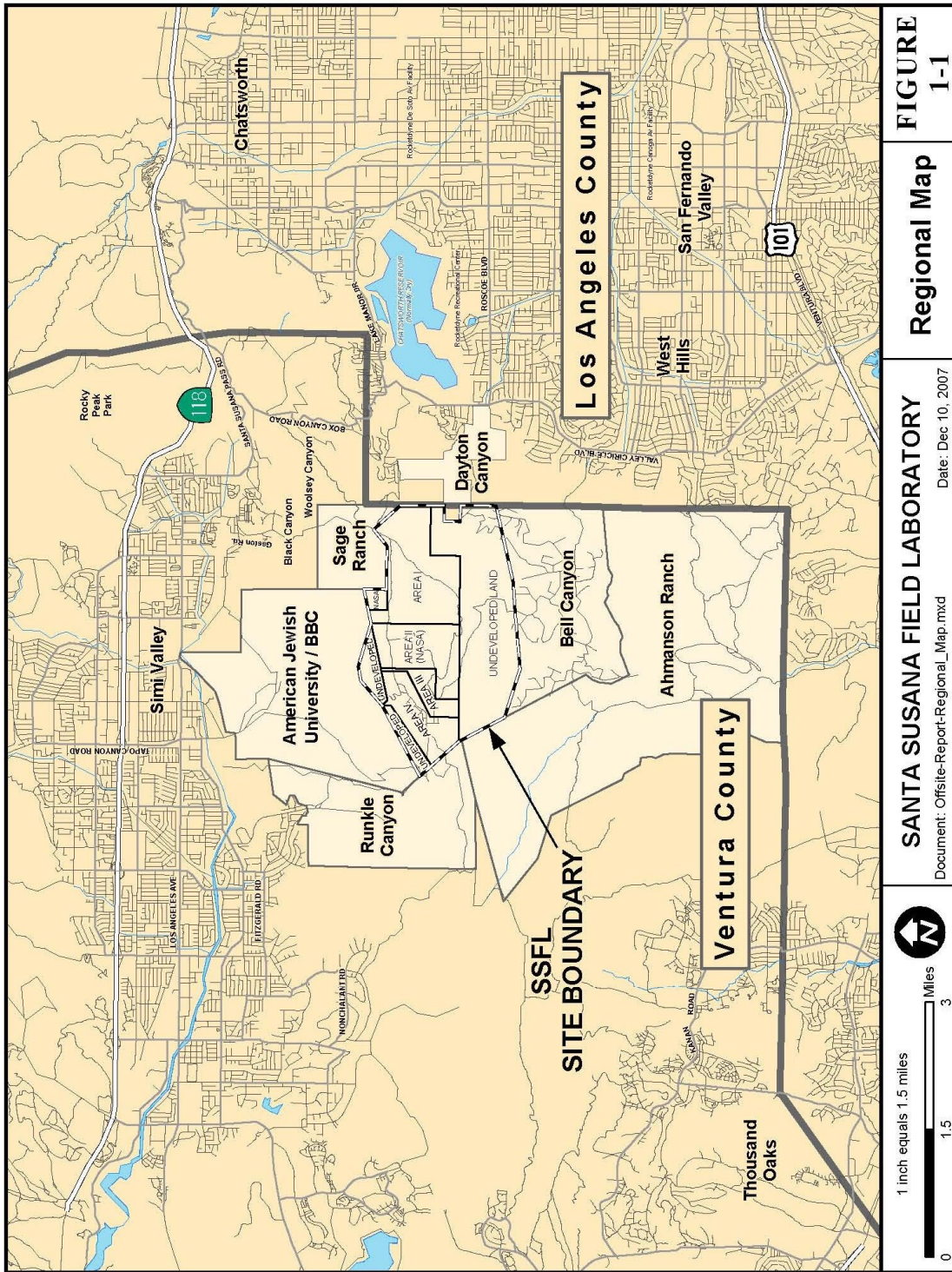

ATTACHMENT C – SITE MAP WITH OUTFALL LOCATIONS

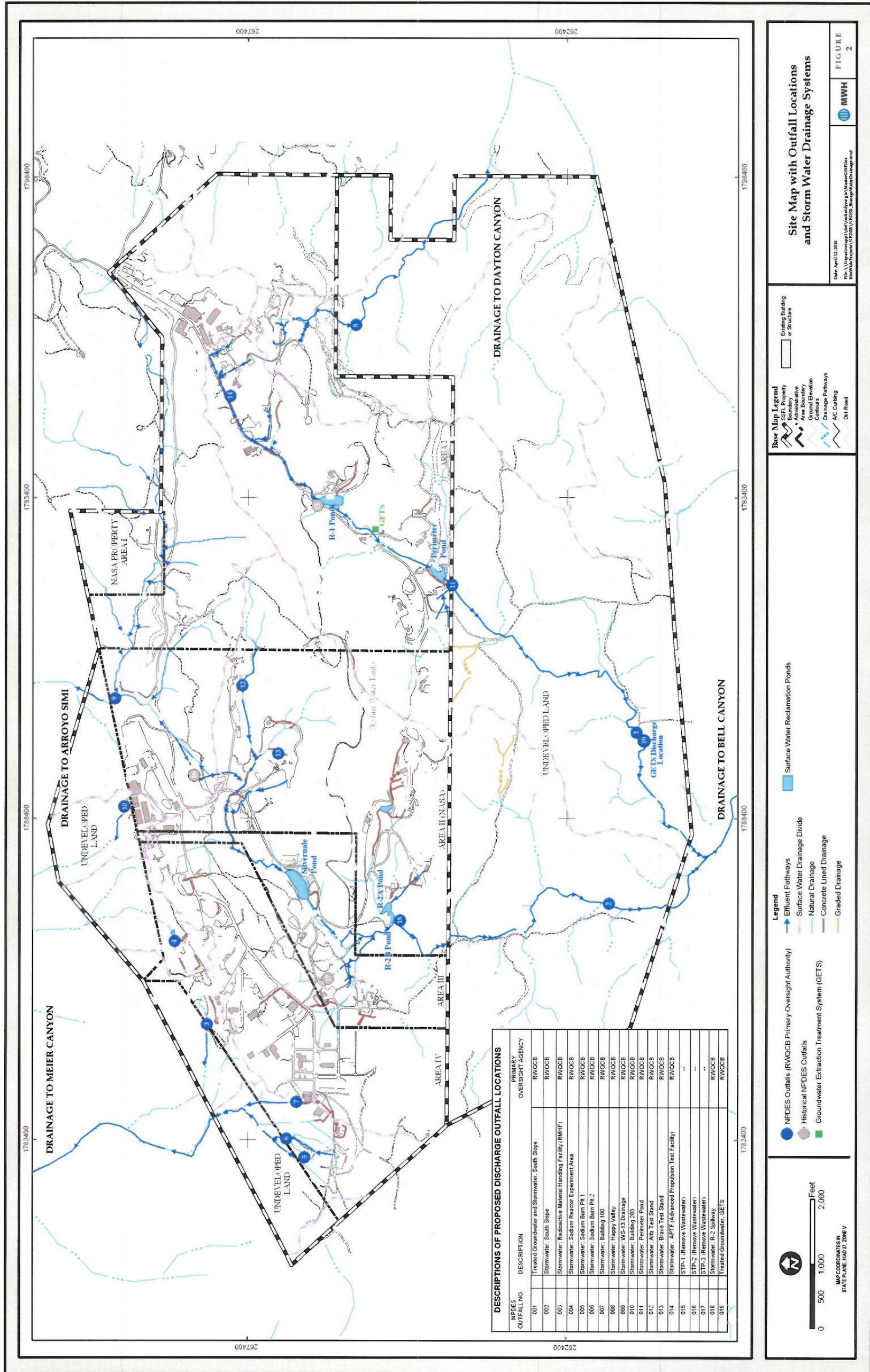

ATTACHMENT D – STANDARD PROVISIONS

I. STANDARD PROVISIONS – PERMIT COMPLIANCE

A. Duty to Comply

1. The Discharger must comply with all of the conditions of this Order. Any noncompliance constitutes a violation of the Clean Water Act (CWA) and the California Water Code and is grounds for enforcement action, for permit termination, revocation and reissuance, or modification; or denial of a permit renewal application [section 122.41(a)].
2. The Discharger shall comply with effluent standards or prohibitions established under Section 307(a) of the CWA for toxic pollutants and with standards for sewage sludge use or disposal established under Section 405(d) of the CWA within the time provided in the regulations that establish these standards or prohibitions, even if this Order has not yet been modified to incorporate the requirement [section 122.41(a)(1)].

B. Need to Halt or Reduce Activity Not a Defense

It shall not be a defense for a Discharger in an enforcement action that it would have been necessary to halt or reduce the permitted activity in order to maintain compliance with the conditions of this Order [section 122.41(c)].

C. Duty to Mitigate

The Discharger shall take all reasonable steps to minimize or prevent any discharge or sludge use or disposal in violation of this Order that has a reasonable likelihood of adversely affecting human health or the environment [section 122.41(d)].

D. Proper Operation and Maintenance

The Discharger shall at all times properly operate and maintain all facilities and systems of treatment and control (and related appurtenances) which are installed or used by the Discharger to achieve compliance with the conditions of this Order. Proper operation and maintenance also includes adequate laboratory controls and appropriate quality assurance procedures. This provision requires the operation of backup or auxiliary facilities or similar systems that are installed by a Discharger only when necessary to achieve compliance with the conditions of this Order [section 122.41(e)].

E. Property Rights

1. This Order does not convey any property rights of any sort or any exclusive privileges [section 122.41(g)].

2. The issuance of this Order does not authorize any injury to persons or property or invasion of other private rights, or any infringement of state or local law or regulations [section 122.5(c)].

F. Inspection and Entry

The Discharger shall allow the Regional Water Board, State Water Board, United States Environmental Protection Agency (USEPA), and/or their authorized representatives (including an authorized contractor acting as their representative), upon the presentation of credentials and other documents, as may be required by law, to [section 122.41(i)] [Water Code section 13383]:

1. Enter upon the Discharger's premises where a regulated facility or activity is located or conducted, or where records are kept under the conditions of this Order [section 122.41(i)(1)];
2. Have access to and copy, at reasonable times, any records that must be kept under the conditions of this Order [section 122.41(i)(2)];
3. Inspect and photograph, at reasonable times, any facilities, equipment (including monitoring and control equipment), practices, or operations regulated or required under this Order [section 122.41(i)(3)]; and
4. Sample or monitor, at reasonable times, for the purposes of assuring Order compliance or as otherwise authorized by the CWA or the Water Code, any substances or parameters at any location [section 122.41(i)(4)].

G. Bypass

1. Definitions
 - e. "Bypass" means the intentional diversion of waste streams from any portion of a treatment facility [section 122.41(m)(1)(i)].
 - f. "Severe property damage" means substantial physical damage to property, damage to the treatment facilities, which causes them to become inoperable, or substantial and permanent loss of natural resources that can reasonably be expected to occur in the absence of a bypass. Severe property damage does not mean economic loss caused by delays in production [section 122.41(m)(1)(ii)].
2. Bypass not exceeding limitations. The Discharger may allow any bypass to occur which does not cause exceedances of effluent limitations, but only if it is for essential maintenance to assure efficient operation. These bypasses are not subject to the provisions listed in Standard Provisions – Permit Compliance I.G.3, I.G.4, and I.G.5 below [section 122.41(m)(2)].

3. Prohibition of bypass. Bypass is prohibited, and the Regional Water Board may take enforcement action against a Discharger for bypass, unless [section 122.41(m)(4)(i)]:
 1. Bypass was unavoidable to prevent loss of life, personal injury, or severe property damage [section 122.41(m)(4)(i)(A)];
 2. There were no feasible alternatives to the bypass, such as the use of auxiliary treatment facilities, retention of untreated wastes, or maintenance during normal periods of equipment downtime. This condition is not satisfied if adequate back-up equipment should have been installed in the exercise of reasonable engineering judgment to prevent a bypass that occurred during normal periods of equipment downtime or preventive maintenance [section 122.41(m)(4)(i)(B)]; and
 3. The Discharger submitted notice to the Regional Water Board as required under Standard Provisions – Permit Compliance I.G.5 below [section 122.41(m)(4)(i)(C)].
 4. The Regional Water Board may approve an anticipated bypass, after considering its adverse effects, if the Regional Water Board determines that it will meet the three conditions listed in Standard Provisions – Permit Compliance I.G.3 above [section 122.41(m)(4)(ii)].
5. Notice
 1. Anticipated bypass. If the Discharger knows in advance of the need for a bypass, it shall submit a notice, if possible at least 10 days before the date of the bypass [section 122.41(m)(3)(i)].
 2. Unanticipated bypass. The Discharger shall submit notice of an unanticipated bypass as required in Standard Provisions - Reporting V.E below (24-hour notice) [section 122.41(m)(3)(ii)].

H. Upset

Upset means an exceptional incident in which there is unintentional and temporary noncompliance with technology based permit effluent limitations because of factors beyond the reasonable control of the Discharger. An upset does not include noncompliance to the extent caused by operational error, improperly designed treatment facilities, inadequate treatment facilities, lack of preventive maintenance, or careless or improper operation [section 122.41(n)(1)].

1. Effect of an upset. An upset constitutes an affirmative defense to an action brought for noncompliance with such technology based permit effluent limitations if the requirements of Standard Provisions – Permit Compliance I.H.2 below are met. No determination made during administrative review of claims that noncompliance was caused by upset, and before an action for noncompliance, is final administrative action subject to judicial review [section 122.41(n)(2)].

2. Conditions necessary for a demonstration of upset. A Discharger who wishes to establish the affirmative defense of upset shall demonstrate, through properly signed, contemporaneous operating logs or other relevant evidence that [section 122.41(n)(3)]:
 1. An upset occurred and that the Discharger can identify the cause(s) of the upset [section 122.41(n)(3)(i)];
 2. The permitted facility was, at the time, being properly operated [section 122.41(n)(3)(ii)];
 3. The Discharger submitted notice of the upset as required in Standard Provisions – Reporting V.E.2.b below (24-hour notice) [section 122.41(n)(3)(iii)]; and
 4. The Discharger complied with any remedial measures required under Standard Provisions – Permit Compliance I.C above [section 122.41(n)(3)(iv)].
3. Burden of proof. In any enforcement proceeding, the Discharger seeking to establish the occurrence of an upset has the burden of proof [section 122.41(n)(4)].

II. STANDARD PROVISIONS – PERMIT ACTION

A. General

This Order may be modified, revoked and reissued, or terminated for cause. The filing of a request by the Discharger for modification, revocation and reissuance, or termination, or a notification of planned changes or anticipated noncompliance does not stay any Order condition [section 122.41(f)].

B. Duty to Reapply

If the Discharger wishes to continue an activity regulated by this Order after the expiration date of this Order, the Discharger must apply for and obtain a new permit [section 122.41(b)].

C. Transfers

This Order is not transferable to any person except after notice to the Regional Water Board. The Regional Water Board may require modification or revocation and reissuance of the Order to change the name of the Discharger and incorporate such other requirements as may be necessary under the CWA and the Water Code [section 122.41(l)(3) and section 122.61].

III. STANDARD PROVISIONS – MONITORING

- A. Samples and measurements taken for the purpose of monitoring shall be representative of the monitored activity [section 122.41(j)(1)].

- B. Monitoring results must be conducted according to test procedures under Part 136 or, in the case of sludge use or disposal, approved under Part 136 unless otherwise specified in Part 503 unless other test procedures have been specified in this Order [section 122.41(j)(4) and section 122.44(i)(1)(iv)].

IV. STANDARD PROVISIONS – RECORDS

- A. Except for records of monitoring information required by this Order related to the Discharger's sewage sludge use and disposal activities, which shall be retained for a period of at least five years (or longer as required by Part 503), the Discharger shall retain records of all monitoring information, including all calibration and maintenance records and all original strip chart recordings for continuous monitoring instrumentation, copies of all reports required by this Order, and records of all data used to complete the application for this Order, for a period of at least three (3) years from the date of the sample, measurement, report or application. This period may be extended by request of the Regional Water Board Executive Officer at any time [section 122.41(j)(2)].
- B. Records of monitoring information shall include:
1. The date, exact place, and time of sampling or measurements [section 122.41(j)(3)(i)];
 2. The individual(s) who performed the sampling or measurements [section 122.41(j)(3)(ii)];
 3. The date(s) analyses were performed [section 122.41(j)(3)(iii)];
 4. The individual(s) who performed the analyses [section 122.41(j)(3)(iv)];
 5. The analytical techniques or methods used [section 122.41(j)(3)(v)]; and
 6. The results of such analyses [section 122.41(j)(3)(vi)].

C. Claims of confidentiality for the following information will be denied [section 122.7(b)]:

1. The name and address of any permit applicant or Discharger [section 122.7(b)(1)]; and
2. Permit applications and attachments, permits and effluent data [section 122.7(b)(2)].

V. STANDARD PROVISIONS – REPORTING

A. Duty to Provide Information

The Discharger shall furnish to the Regional Water Board, State Water Board, or USEPA within a reasonable time, any information which the Regional Water Board, State Water Board, or USEPA may request to determine whether cause exists for modifying, revoking and reissuing, or terminating this Order or to determine compliance

with this Order. Upon request, the Discharger shall also furnish to the Regional Water Board, State Water Board, or USEPA copies of records required to be kept by this Order [section 122.41(h)] [Water Code section 13267].

B. Signatory and Certification Requirements

1. All applications, reports, or information submitted to the Regional Water Board, State Water Board, and/or USEPA shall be signed and certified in accordance with Standard Provisions – Reporting V.B.2, V.B.3, V.B.4, and V.B.5 below [section 122.41(k)].
2. All permit applications shall be signed by a responsible corporate officer. For the purpose of this section, a responsible corporate officer means: (i) A president, secretary, treasurer, or vice-president of the corporation in charge of a principal business function, or any other person who performs similar policy- or decision-making functions for the corporation, or (ii) the manager of one or more manufacturing, production, or operating facilities, provided, the manager is authorized to make management decisions which govern the operation of the regulated facility including having the explicit or implicit duty of making major capital investment recommendations, and initiating and directing other comprehensive measures to assure long term environmental compliance with environmental laws and regulations; the manager can ensure that the necessary systems are established or actions taken to gather complete and accurate information for permit application requirements; and where authority to sign documents has been assigned or delegated to the manager in accordance with corporate procedures. [section 122.22(a)(1)].
3. All reports required by this Order and other information requested by the Regional Water Board, State Water Board, or USEPA shall be signed by a person described in Standard Provisions – Reporting V.B.2 above, or by a duly authorized representative of that person. A person is a duly authorized representative only if:
 - a. The authorization is made in writing by a person described in Standard Provisions – Reporting V.B.2 above [section 122.22(b)(1)];
 - b. The authorization specifies either an individual or a position having responsibility for the overall operation of the regulated facility or activity such as the position of plant manager, operator of a well or a well field, superintendent, position of equivalent responsibility, or an individual or position having overall responsibility for environmental matters for the company. (A duly authorized representative may thus be either a named individual or any individual occupying a named position.) [section 122.22(b)(2)]; and
 - c. The written authorization is submitted to the Regional Water Board and State Water Board [section 122.22(b)(3)].
4. If an authorization under Standard Provisions – Reporting V.B.3 above is no longer accurate because a different individual or position has responsibility for the overall

operation of the facility, a new authorization satisfying the requirements of Standard Provisions – Reporting V.B.3 above must be submitted to the Regional Water Board and State Water Board prior to or together with any reports, information, or applications, to be signed by an authorized representative [section 122.22(c)].

5. Any person signing a document under Standard Provisions – Reporting V.B.2 or V.B.3 above shall make the following certification:

“I certify under penalty of law that this document and all attachments were prepared under my direction or supervision in accordance with a system designed to assure that qualified personnel properly gather and evaluate the information submitted. Based on my inquiry of the person or persons who manage the system or those persons directly responsible for gathering the information, the information submitted is, to the best of my knowledge and belief, true, accurate, and complete. I am aware that there are significant penalties for submitting false information, including the possibility of fine and imprisonment for knowing violations.” [section 122.22(d)].

C. Monitoring Reports

1. Monitoring results shall be reported at the intervals specified in the Monitoring and Reporting Program (Attachment E) in this Order [section 122.22(l)(4)].
2. Monitoring results must be reported on a Discharge Monitoring Report (DMR) form or forms provided or specified by the Regional Water Board or State Water Board for reporting results of monitoring of sludge use or disposal practices [section 122.41(l)(4)(i)].
3. If the Discharger monitors any pollutant more frequently than required by this Order using test procedures approved under Part 136 or, in the case of sludge use or disposal, approved under Part 136 unless otherwise specified in Part 503, or as specified in this Order, the results of this monitoring shall be included in the calculation and reporting of the data submitted in the DMR or sludge reporting form specified by the Regional Water Board [section 122.41(l)(4)(ii)].
4. Calculations for all limitations, which require averaging of measurements, shall utilize an arithmetic mean unless otherwise specified in this Order [section 122.41(l)(4)(iii)].

D. Compliance Schedules

Reports of compliance or noncompliance with, or any progress reports on, interim and final requirements contained in any compliance schedule of this Order, shall be submitted no later than 14 days following each schedule date [section 122.41(l)(5)].

E. Twenty-Four Hour Reporting

1. The Discharger shall report any noncompliance that may endanger health or the environment. Any information shall be provided orally within 24 hours from the time the Discharger becomes aware of the circumstances. A written submission shall also be provided within five (5) days of the time the Discharger becomes aware of the circumstances. The written submission shall contain a description of the noncompliance and its cause; the period of noncompliance, including exact dates and times, and if the noncompliance has not been corrected, the anticipated time it is expected to continue; and steps taken or planned to reduce, eliminate, and prevent reoccurrence of the noncompliance [section 122.41(l)(6)(i)].
2. The following shall be included as information that must be reported within 24 hours under this paragraph [section 122.41(l)(6)(ii)]:
3. Any unanticipated bypass that exceeds any effluent limitation in this Order [section 122.41(l)(6)(ii)(A)].
4. Any upset that exceeds any effluent limitation in this Order [section 122.41(l)(6)(ii)(B)].
5. The Regional Water Board may waive the above-required written report under this provision on a case-by-case basis if an oral report has been received within 24 hours [section 122.41(l)(6)(iii)].

F. Planned Changes

The Discharger shall give notice to the Regional Water Board as soon as possible of any planned physical alterations or additions to the permitted facility. Notice is required under this provision only when [section 122.41(l)(1)]:

1. The alteration or addition to a permitted facility may meet one of the criteria for determining whether a facility is a new source in section 122.29(b) [section 122.41(l)(1)(i)]; or
2. The alteration or addition could significantly change the nature or increase the quantity of pollutants discharged. This notification applies to pollutants that are not subject to effluent limitations in this Order [section 122.41(l)(1)(ii)].

The alteration or addition could significantly change the nature or increase the quantity of pollutants discharged. This notification applies to pollutants that are subject neither to effluent limitations in this Order nor to notification requirements under section 122.42(a)(1) (see Additional Provisions—Notification Levels VII.A.1) [section 122.41(l)(1)(ii)].

3. The alteration or addition results in a significant change in the Discharger's sludge use or disposal practices, and such alteration, addition, or change may justify the application of permit conditions that are different from or absent in the existing permit, including notification of additional use or disposal sites not reported during the permit application process or not reported pursuant to an approved land application plan [section 122.41(l)(1)(iii)].

G. Anticipated Noncompliance

The Discharger shall give advance notice to the Regional Water Board or State Water Board of any planned changes in the permitted facility or activity that may result in noncompliance with General Order requirements [section 122.41(l)(2)].

H. Other Noncompliance

The Discharger shall report all instances of noncompliance not reported under Standard Provisions – Reporting V.C, V.D, and V.E above at the time monitoring reports are submitted. The reports shall contain the information listed in Standard Provision – Reporting V.E above [section 122.41(l)(7)].

I. Other Information

When the Discharger becomes aware that it failed to submit any relevant facts in a permit application, or submitted incorrect information in a permit application or in any report to the Regional Water Board, State Water Board, or USEPA, the Discharger shall promptly submit such facts or information [section 122.41(l)(8)].

VI. STANDARD PROVISIONS – ENFORCEMENT

- A.** The Regional Water Board is authorized to enforce the terms of this permit under several provisions of the Water Code, including, but not limited to, sections 13385, 13386, and 13387.
- B.** The CWA provides that any person who violates section 301, 302, 306, 307, 308, 318 or 405 of the Act, or any permit condition or limitation implementing any such sections in a permit issued under section 402, or any requirement imposed in a pretreatment program approved under sections 402(a)(3) or 402(b)(8) of the Act, is subject to a civil penalty not to exceed \$25,000 per day for each violation. The CWA provides that any person who negligently violates sections 301, 302, 306, 307, 308, 318, or 405 of the Act, or any condition or limitation implementing any of such sections in a permit issued under section 402 of the Act, or any requirement imposed in a pretreatment program approved under section 402(a)(3) or 402(b)(8) of the Act, is subject to criminal penalties of \$2,500 to \$25,000 per day of violation, or imprisonment of not more than one (1) year, or both. In the case of a second or subsequent conviction for a negligent violation, a person shall be subject to criminal penalties of not more than \$50,000 per day of violation, or by imprisonment of not more than two (2) years, or both. Any person who knowingly violates such sections, or such conditions or limitations is subject to criminal penalties of \$5,000 to \$50,000 per day of violation, or imprisonment for not more than

three (3) years, or both. In the case of a second or subsequent conviction for a knowing violation, a person shall be subject to criminal penalties of not more than \$100,000 per day of violation, or imprisonment of not more than six (6) years, or both. Any person who knowingly violates section 301, 302, 303, 306, 307, 308, 318 or 405 of the Act, or any permit condition or limitation implementing any of such sections in a permit issued under section 402 of the Act, and who knows at that time that he thereby places another person in imminent danger of death or serious bodily injury, shall, upon conviction, be subject to a fine of not more than \$250,000 or imprisonment of not more than 15 years, or both. In the case of a second or subsequent conviction for a knowing endangerment violation, a person shall be subject to a fine of not more than \$500,000 or by imprisonment of not more than 30 years, or both. An organization, as defined in section 309(c)(3)(B)(iii) of the CWA, shall, upon conviction of violating the imminent danger provision, be subject to a fine of not more than \$1,000,000 and can be fined up to \$2,000,000 for second or subsequent convictions [*section 122.41(a)(2)*] [*Water Code sections 13385 and 13387*].

- C. Any person may be assessed an administrative penalty by the Regional Water Board for violating section 301, 302, 306, 307, 308, 318 or 405 of this Act, or any permit condition or limitation implementing any of such sections in a permit issued under section 402 of this Act. Administrative penalties for Class I violations are not to exceed \$10,000 per violation, with the maximum amount of any Class I penalty assessed not to exceed \$25,000. Penalties for Class II violations are not to exceed \$10,000 per day for each day during which the violation continues, with the maximum amount of any Class II penalty not to exceed \$125,000 [*section 122.41(a)(3)*].
- D. The CWA provides that any person who falsifies, tampers with, or knowingly renders inaccurate any monitoring device or method required to be maintained under this permit shall, upon conviction, be punished by a fine of not more than \$10,000, or by imprisonment for not more than 2 years, or both. If a conviction of a person is for a violation committed after a first conviction of such person under this paragraph, punishment is a fine of not more than \$20,000 per day of violation, or by imprisonment of not more than 4 years, or both [*section 122.41(j)(5)*].
- E. The CWA provides that any person who knowingly makes any false statement, representation, or certification in any record or other document submitted or required to be maintained under this Order, including monitoring reports or reports of compliance or noncompliance shall, upon conviction, be punished by a fine of not more than \$10,000 per violation, or by imprisonment for not more than six months per violation, or by both [*section 122.41(k)(2)*].

VII. ADDITIONAL PROVISIONS – NOTIFICATION LEVELS

A. Non-Municipal Facilities

Dischargers shall notify the Regional Water Board as soon as they know or have reason to believe [*section 122.42(a)*]:

1. That any activity has occurred or will occur that would result in the discharge, on a routine or frequent basis, of any toxic pollutant that is not limited in this Order, if that discharge will exceed the highest of the following "notification levels" [section 122.42(a)(1)]:
 - a. 100 micrograms per liter ($\mu\text{g/L}$) [section 122.42(a)(1)(i)];
 - b. 200 $\mu\text{g/L}$ for acrolein and acrylonitrile; 500 $\mu\text{g/L}$ for 2,4-dinitrophenol and 2-methyl-4,6-dinitrophenol; and 1 milligram per liter (mg/L) for antimony [section 122.42(a)(1)(ii)];
 - c. Five (5) times the maximum concentration value reported for that pollutant in the Report of Waste Discharge [section 122.42(a)(1)(iii)]; or
 - d. The level established by the Regional Water Board in accordance with section 122.44(f) [section 122.42(a)(1)(iv)].
2. That any activity has occurred or will occur that would result in the discharge, on a non-routine or infrequent basis, of any toxic pollutant that is not limited in this Order, if that discharge will exceed the highest of the following "notification levels" [section 122.42(a)(2)]:
 - a. 500 micrograms per liter ($\mu\text{g/L}$) [section 122.42(a)(2)(i)];
 - b. 1 milligram per liter (mg/L) for antimony [section 122.42(a)(2)(ii)];
 - c. Ten (10) times the maximum concentration value reported for that pollutant in the Report of Waste Discharge [section 122.42(a)(2)(iii)]; or
 - d. The level established by the Regional Water Board in accordance with section 122.44(f) [section 122.42(a)(2)(iv)].

ATTACHMENT E – MONITORING AND REPORTING PROGRAM (MRP NO. 6027)

Table of Contents

I.	General Monitoring Provisions.....	E-2
II.	Monitoring Locations	E-5
III.	Influent Monitoring Requirements.....	E-7
IV.	Effluent Monitoring Requirements	E-7
	A. Monitoring Location EFF-001, EFF-002, EFF-011, EFF-018	E-7
	B. Monitoring Location EFF-003 - EFF-010.....	E-10
	C. Monitoring Location EFF-012, EFF-013, and EFF-014	E-11
	D. Monitoring Location EFF-019 – The Groundwater Treatment System.....	E-13
V.	Whole Effluent Toxicity Testing Requirements	E-18
	A. Definition of Toxicity.....	E-18
VI.	Land Discharge Monitoring Requirements	E-25
VII.	Reclamation Monitoring Requirements.....	E-25
VIII.	Receiving Water Monitoring Requirements – Surface Water.....	E-25
	A. Monitoring Locations RSW-001 (Bell Creek) and RSW-002 (Arroyo Simi).	E-25
	B. Receiving Water Surveys.....	E-27
IX.	Sediment Sampling	E-28
X.	Bioassessment Monitoring.....	E-29
XI.	Other Monitoring Requirements.....	E-31
XII.	Reporting Requirements.....	E-31

List of Tables

Table E-1.	Monitoring Station Locations.....	E-6
Table E-2a.	Effluent Monitoring - EFF-001, EFF-002, EFF-011, EFF-018.....	E-8
Table E-2b.	Effluent Monitoring - EFF-003 - EFF-010	E-10
Table E-2c.	Effluent Monitoring - EFF-012, EFF-013, and EFF-014.....	E-11
Table E-2d.	Effluent Monitoring - EFF-019	E-13
Table E-3.	Receiving Water Monitoring Requirements – RSW-001 and RSW-002	E-25
Table E-3.	Receiving Water Sediment Monitoring Requirements.....	E-29

ATTACHMENT E – MONITORING AND REPORTING PROGRAM (MRP) NO. 6027

The Code of Federal Regulations section 122.48 requires that all NPDES permits specify monitoring and reporting requirements. Water Code Sections 13267 and 13383 also authorize the Regional Water Quality Control Board (Regional Water Board) to require technical and monitoring reports. This MRP establishes monitoring and reporting requirements, which implement the federal and California regulations.

I. GENERAL MONITORING PROVISIONS

- A. All effluent sampling stations shall be established for the point of discharge as defined in Table E-1 and shall be located where representative samples of that effluent can be obtained.
- B. The Regional Water Board shall be notified in writing of any change in the sampling stations once established or in the methods for determining the quantities of pollutants in the individual waste streams.
- C. Each monitoring report shall contain a separate section titled “Summary of Non-Compliance” which discusses the compliance record and corrective actions taken or planned that may be needed to bring the discharge into full compliance with waste discharge requirements. This section shall clearly list all non-compliance with waste discharge requirements, as well as all excursions of effluent limitations.

Each quarterly report shall contain a separate section titled “Reasonable Potential Analysis” which discusses whether or not reasonable potential was triggered for pollutants which do not have a final effluent limitation in the NPDES permit. This section shall contain the following statement, “The analytical results for this sampling period did/did not trigger reasonable potential.” If reasonable potential was triggered, then the following information should be provided:

- a. A list of the pollutant(s) that triggered reasonable potential;
 - b. The Basin Plan or CTR criteria that was exceeded for each given pollutant;
 - c. The concentration of the pollutant(s);
 - d. The test method used to analyze the sample; and
 - e. The data and time of sample collection.
- D. Pollutants shall be analyzed using the analytical methods described in sections 136.3, 136.4, and 136.5 (revised May 12, 2007); or, where no methods are specified for a given pollutant, by methods approved by this Regional Water Board or the State Water Board. Laboratories analyzing effluent samples and receiving water samples shall be certified by the California Department of Public Health Environmental Laboratory Accreditation Program (ELAP) or approved by the Executive Officer and must include quality assurance/quality control (QA/QC) data in their reports. A copy of the laboratory certification shall be provided each time a new certification and/or renewal of the certification is obtained from ELAP. For purposes of monitoring pH, dissolved oxygen,

residual chlorine, and temperature, tests may be conducted at the field sampling location provided that all the requirements of the approved analytical methods for NPDES use in 40 CFR 136 are met.

- E. For any analyses performed for which no procedure is specified in the USEPA guidelines or in the MRP, the constituent or parameter analyzed and the method or procedure used must be specified in the monitoring report.
- F. Each monitoring report must affirm in writing that “all analyses were conducted at a laboratory certified for such analyses by the Department of Public Health or approved by the Executive Officer and in accordance with current USEPA guideline procedures or as specified in this MRP”.
- G. The monitoring reports shall specify the analytical method used, the Method Detection Limit (MDL), and the Minimum Level (ML) for each pollutant. For the purpose of reporting compliance with numerical limitations, benchmarks, and receiving water limitations, analytical data shall be reported by one of the following methods, as appropriate:
 - 1. An actual numerical value for sample results greater than or equal to the ML; or
 - 2. “Detected, but Not Quantified (DNQ)” if results are greater than or equal to the laboratory’s MDL but less than the ML; or,
 - 3. “Not-Detected (ND)” for sample results less than the laboratory’s MDL with the MDL indicated for the analytical method used.

Analytical data reported as “less than” for the purpose of reporting compliance with permit limitations shall be the same or lower than the permit limit(s) established for the given parameter.

Current MLs (Attachment H) are those published by the State Water Board in the Policy for the Implementation of Toxics Standards for Inland Surface Waters, Enclosed Bays, and Estuaries of California, February 24, 2005.

- H. Where possible, the MLs employed for effluent analyses shall be lower than the permit limitations established for a given parameter. If the ML value is not below the effluent limitation, then the lowest ML value and its associated analytical method shall be selected for compliance purposes. At least once a year, the Discharger shall submit a list of the analytical methods employed for each test and associated laboratory QA/QC procedures.

The Regional Water Board, in consultation with the State Water Board Quality Assurance Program, shall establish a ML that is not contained in Attachment H to be included in the Discharger’s permit in any of the following situations:

1. When the pollutant under consideration is not included in Attachment H;
 2. When the Discharger and Regional Water Board agree to include in the permit a test method that is more sensitive than that specified in 40 CFR Part 136 (revised March 12, 2007);
 3. When the Discharger agrees to use an ML that is lower than that listed in Attachment H;
 4. When the Discharger demonstrates that the calibration standard matrix is sufficiently different from that used to establish the ML in Attachment H, and proposes an appropriate ML for their matrix; or,
 5. When the Discharger uses a method whose quantification practices are not consistent with the definition of an ML. Examples of such methods are the USEPA-approved method 1613 for dioxins and furans, method 1624 for volatile organic substances, and method 1625 for semi-volatile organic substances. In such cases, the Discharger, the Regional Water Board, and the State Water Board shall agree on a lowest quantifiable limit and that limit will substitute for the ML for reporting and compliance determination purposes.
- I. Water/wastewater samples must be analyzed within allowable holding time limits as specified in section 136.3. All QA/QC items must be run on the same dates the samples were actually analyzed, and the results shall be reported in the Regional Water Board format, when it becomes available, and submitted with the laboratory reports. Proper chain of custody procedures must be followed, and a copy of the chain of custody shall be submitted with the report.
 - J. All analyses shall be accompanied by the chain of custody, including but not limited to data and time of sampling, sample identification, and name of person who performed sampling, date of analysis, name of person who performed analysis, QA/QC data, method detection limits, analytical methods, copy of laboratory certification, and a perjury statement executed by the person responsible for the laboratory.
 - K. The Discharger shall calibrate and perform maintenance procedures on all monitoring instruments and to insure accuracy of measurements, or shall insure that both equipment activities will be conducted.
 - L. The Discharger shall have, and implement, an acceptable written quality assurance (QA) plan for laboratory analyses. The annual monitoring report required in Section XII.D.3 shall also summarize the QA activities for the previous year. Duplicate chemical analyses must be conducted on a minimum of ten percent (10%) of the samples, or at least one sample per sampling period, whichever is greater. A similar frequency shall be maintained for analyzing spiked samples.

- M. When requested by the Regional Water Board or USEPA, the Discharger will participate in the NPDES discharge monitoring report QA performance study. The Discharger must have a success rate equal to or greater than 80%.
- N. For parameters that both average monthly and daily maximum limits are specified and the monitoring frequency is less than four times a month, the following shall apply. If an analytical result is greater than the average monthly limit, the Discharger shall collect four additional samples at approximately equal intervals during the month, until compliance with the average monthly limit has been demonstrated. All five analytical results shall be reported in the monitoring report for that month, or 45 days after results for the additional samples were received, whichever is later. In the event of noncompliance with an average monthly effluent limitation, the sampling frequency for that constituent shall be increased to weekly and shall continue at this level until compliance with the average monthly effluent limitation has been demonstrated. The Discharger shall provide for the approval of the Executive Officer a program to ensure future compliance with the average monthly limit.
- O. In the event wastes are transported to a different disposal site during the report period, the following shall be reported in the monitoring report:
1. Types of wastes and quantity of each type;
 2. Name and address for each hauler of wastes (or method of transport if other than by hauling); and
 3. Location of the final point(s) of disposal for each type of waste.
- If no wastes are transported off-site during the reporting period, a statement to that effect shall be submitted.
- P. Each monitoring report shall state whether or not there was any change in the discharge as described in the Order during the reporting period.
- Q. Laboratories analyzing monitoring samples shall be certified by the Department of Public Health, in accordance with the provision of Water Code section 13176, and must include quality assurance/quality control data with their reports.

II. MONITORING LOCATIONS

The Discharger shall establish the following monitoring locations to demonstrate compliance with the effluent limitations, discharge specifications, and other requirements in this Order:

Table E-1. Monitoring Station Locations

Discharge Point Name	Monitoring Location Name	Monitoring Location Description
001	EFF-001	Effluent shall be sampled at the point of discharge into the unnamed canyon tributary to Bell Creek
002	EFF-002	Effluent shall be sampled at the point of discharge into the unnamed canyon tributary to Bell Creek
003	EFF-003	Effluent shall be sampled at the point of discharge into the unnamed canyon tributary to Arroyo Simi
004	EFF-004	Effluent shall be sampled at the point of discharge into the unnamed canyon tributary to Arroyo Simi
005	EFF-005	Effluent shall be sampled at the point of discharge into the unnamed canyon tributary to Arroyo Simi
006	EFF-006	Effluent shall be sampled at the point of discharge into the unnamed canyon tributary to Arroyo Simi
007	EFF-007	Effluent shall be sampled at the point of discharge into the unnamed canyon tributary to Arroyo Simi
008	EFF-008	Effluent shall be sampled at the point of discharge into the unnamed canyon tributary to Bell Creek
009	EFF-009	Effluent shall be sampled at the point of discharge into the unnamed canyon tributary to Arroyo Simi
010	EFF-010	Effluent shall be sampled at the point of discharge into the unnamed canyon tributary to Arroyo Simi
011	EFF-011	Effluent shall be sampled at the point of discharge into the unnamed canyon tributary to Bell Creek
012	EFF-012	Effluent shall be sampled at the point of discharge into the unnamed canyon tributary to Bell Creek
013	EFF-013	Effluent shall be sampled at the point of discharge into the unnamed canyon tributary to Bell Creek
014	EFF-014	Effluent shall be sampled at the point of discharge into the unnamed canyon tributary to Bell Creek
015		No longer used
016		No longer used
017		No longer used
018	EFF-018	Effluent shall be sampled at the point of discharge into the unnamed canyon tributary to Bell Creek
019	EFF-019	Effluent shall be sampled at the point of discharge into the unnamed canyon tributary to Bell Creek
	RSW-001	Receiving water sampling requirements are satisfied by sampling of priority pollutants on the discharge, from EFF-001, EFF-002, EFF-011, or EFF-018, which is essentially the headwaters of Bell Creek.

Discharge Point Name	Monitoring Location Name	Monitoring Location Description
	RSW-002	A sampling station has been established in Frontier Park downstream of the discharge point into Arroyo Simi, the receiving water.

III. INFLUENT MONITORING REQUIREMENTS

Not applicable

IV. EFFLUENT MONITORING REQUIREMENTS

A. Monitoring Location EFF-001, EFF-002, EFF-011, EFF-018

- A. The Discharger shall monitor storm water runoff and treated groundwater effluent as follows. If more than one analytical test method is listed for a given parameter, the Discharger must select from the listed methods and corresponding Minimum Level:

Table E-2a. Effluent Monitoring - EFF-001, EFF-002, EFF-011, EFF-018

Parameter	Units	Sample Type	Minimum Sampling Frequency ¹	Required Analytical Test Method
Flow	gpd (gallons per day)	Measure	1/Discharge	--
Rainfall	Inches	Continuous	Daily	--
Biochemical Oxygen Demand (BOD)(5-day @20 Deg. C)	mg/L	Composite	1/Discharge	2
Temperature	°F	Grab	1/Discharge	2
Oil and Grease	mg/L	Grab	1/Discharge	2
Conductivity at 25 °C	µmhos/cm	Grab	1/Discharge	
pH	s.u.	Grab	1/Discharge	2
Total Suspended Solids (TSS)	mg/L	Composite	1/Discharge	2
Total organic carbon	mg/L	Composite	1/Year	2
Hardness (as mg/L CaCO ₃)	mg/L	Composite	1/Year	2
Detergents (as MBAS)	mg/L	Composite	1/Discharge	2
Cyanide	µg/L	Grab	1/Discharge	2
Copper, Total Recoverable	µg/L	Composite	1/Discharge	2
Lead, Total Recoverable	µg/L	Composite	1/Discharge	2
Mercury, Total Recoverable	µg/L	Composite	1/Discharge	2
1,1-Dichloroethylene	µg/L	Grab	1/Discharge	2
1,2-Dichloroethane	µg/L	Grab	1/Discharge	2
Perchlorate	µg/L	Composite	1/Discharge	2
2,4,6-Trichlorophenol	µg/L	Composite	1/Discharge	2
2,4-Dinitrotoluene	µg/L	Composite	1/Discharge	2
Alpha-BHC	µg/L	Composite	1/Discharge	2
Bis(2-ethylhexyl)phthalate	µg/L	Composite	1/Discharge	2
N-Nitrosodimethylamine	µg/L	Composite	1/Discharge	2
Pentachlorophenol	µg/L	Composite	1/Discharge	2
Trichloroethylene	µg/L	Grab	1/Discharge	2
TCDD ¹¹	µg/L	Composite	1/Discharge	2
Volatile organic compounds	µg/L	Grab	1/Quarter	2
Boron	mg/L	Composite	1/Year ¹⁴	2
Fluoride	mg/L	Composite	1/Year ¹⁴	2
Barium	mg/L	Composite	1/Year ¹⁴	2
Iron	mg/L	Composite	1/Year ¹⁴	2
Manganese	µg/L	Composite	1/Year ¹⁴	2
Antimony	µg/L	Composite	1/Year ¹⁴	2
Total Arsenic	µg/L	Composite	1/Year ¹⁴	2
Total Beryllium	µg/L	Composite	1/Year ¹⁴	2
Total Cadmium	µg/L	Composite	1/Discharge	2
Total Chromium VI ⁸	µg/L	Composite	1/Year ¹⁴	2

Parameter	Units	Sample Type	Minimum Sampling Frequency ¹	Required Analytical Test Method
Total Nickel	µg/L	Composite	1/Year ¹⁴	2
Total Selenium	µg/L	Composite	1/Discharge	2
Total Silver	µg/L	Composite	1/Year ¹⁴	2
Total Thallium	µg/L	Composite	1/Year ¹⁴	2
Total Zinc	µg/L	Composite	1/Discharge	2
Cobalt	µg/L	Composite	1/Year	2
Vanadium	µg/L	Composite	1/Year	2
Ammonia – N	mg/L	Composite	1/Discharge	2,3
Nitrate + Nitrite-N	mg/L	Composite	1/Discharge	2
Nitrate – N	mg/L	Composite	1/Discharge	2
Nitrite – N	mg/L	Composite	1/Discharge	2
Chloride	mg/L	Composite	1/Discharge	2
Chlorine, Total Residual	mg/L	Grab	1/Year	2
Dissolved Oxygen	mg/L	Grab	1/Discharge	2
Settleable Solids	ml/L	Grab	1/Discharge	2
Sulfate	mg/L	Composite	1/Discharge	2
Total Dissolved Solids	mg/L	Composite	1/Discharge	2
Fecal coliform	(MPN per 100 mL)	Grab	1/Year	2
E. coli	(MPN per 100 mL)	Grab	1/Year	2
Toxicity, Acute	% survival	Composite	1/Year	2,5
Toxicity, Chronic	TUc	Composite	1 st and 2 nd rain events of each year	2,5
Turbidity	NTU	Grab	1/Discharge	2
Radioactivity- Gross Alpha Gross Beta	pCi/L pCi/L	Composite Composite	1/Discharge 1/Discharge	6
Combined Radium 226 & Radium 228 ⁷	pCi/L	Composite	1/Discharge	2
Tritium (H-3)	pCi/L	Composite	1/Discharge	2
Strontium-90	pCi/L	Composite	1/Discharge	2, 6, 7
K-40 (Potassium-40)	pCi/L	Composite	1/Discharge	2, 6, 7
CS-137	pCi/L	Composite	1/Discharge	2, 6, 7
Uranium	pCi/L	Composite	1/Discharge	2, 6, 7
PCBs	µg/L	Composite	1/Year	2
TPH ⁹	µg/L	Grab	1/Year	2
Monomethyl hydrazine ¹⁰	µg/L	Composite	1/Year	2
cis-1,2-Dichloroethene	µg/L	Grab	1/Year	2
1,4-Dioxane	µg/L	Composite	1/Year	2
1,1,2-Trichloro-1,2,2-	µg/L	Composite	1/Quarter	2

Parameter	Units	Sample Type	Minimum Sampling Frequency ¹	Required Analytical Test Method
trifluoroethane				
1,2-Dichloro-1,1,2-trifluoroethane	µg/L	Composite	1/Year	2
Cyclohexane	µg/L	Grab	1/Year	2
Remaining Priority Pollutants ⁴	µg/L	Composite or Grab as appropriate	1/Year	2

B. Monitoring Location EFF-003 - EFF-010

The Discharger shall monitor storm water runoff effluent as follows. If more than one analytical test method is listed for a given parameter, the Discharger must select from the listed methods and corresponding Minimum Level:

Table E-2b. Effluent Monitoring - EFF-003 - EFF-010

Parameter	Units	Sample Type	Minimum Sampling Frequency ¹	Required Analytical Test Method
Flow	gpd (gallons per day)	Measure	1/Discharge	--
Rainfall	Inches	Continuous	Continuous	--
Oil and Grease	mg/L	Grab	1/Discharge	2
pH	s.u.	Grab	1/Discharge	2
Total Suspended Solids (TSS)	mg/L	Composite	1/Year	2
Hardness (as mg/L CaCO ₃)	mg/L	Composite	1/Year	2
Copper, Total Recoverable	µg/L	Composite	1/Discharge	2
Lead, Total Recoverable	µg/L	Composite	1/Discharge	2
Mercury, Total Recoverable	µg/L	Composite	1/Discharge	2
Perchlorate	µg/L	Composite	1/Discharge ¹²	2
TCDD ¹¹	µg/L	Composite	1/Discharge	2
Boron	mg/L	Composite	1/Year ¹⁴	2
Fluoride	mg/L	Composite	1/Year	2
Iron	mg/L	Composite	1/Year	2
Total Antimony	µg/L	Composite	1/Discharge	2
Total Cadmium	µg/L	Composite	1/Discharge	2
Total Selenium ¹³	µg/L	Composite	1/Discharge	2
Total Thallium	µg/L	Composite	1/Discharge	2
Total Zinc ¹³	µg/L	Composite	1/Discharge	2
Total cyanide	µg/L	Composite	1/Discharge	2
Total Vanadium	µg/L	Composite	1/Year	2
Total Aluminum	µg/L	Composite	1/Year	2
Chlorpyrifos	µg/L	Composite	1/Year ¹⁴	2

Parameter	Units	Sample Type	Minimum Sampling Frequency ¹	Required Analytical Test Method
Diazinon	µg/L	Composite	1/Year ¹⁴	2
Ammonia – N ^{3,13}	mg/L	Composite	1/Discharge	2
Nitrate + Nitrite-N	mg/L	Composite	1/Discharge	2
Nitrate – N ¹³	mg/L	Composite	1/Discharge	2
Nitrite – N ¹³	mg/L	Composite	1/Discharge	2
Chloride	mg/L	Composite	1/Discharge	2
Sulfate	mg/L	Composite	1/Discharge	2
Temperature	°F	Grab	1/Discharge	2
Total Dissolved Solids	mg/L	Composite	1/Discharge	2
Radioactivity- Gross Alpha	pCi/L	Composite	1/Discharge	2, 6
Gross Beta	pCi/L	Composite	1/Discharge	2, 6
Combined Radium 226 & Radium 228 ⁷	pCi/L	Composite	1/Discharge	2
Tritium (H-3)	pCi/L	Composite	1/Discharge	2
Strontium-90	pCi/L	Composite	1/Discharge	2, 6
K-40 (Potassium-40)	pCi/L	Composite	1/Discharge	2, 6
Cs-137	pCi/L	Composite	1/Discharge	2
Uranium	pCi/L	Composite	1/Discharge	2
Toxicity, Acute	% survival	Composite	1/Year	2, 5
Toxicity, Chronic	TUc	Composite	1 st and 2 nd rain events of each year	2
Fecal coliform	(MPN per 100 mL)	Grab	1/Year	2
E. coli	(MPN per 100 mL)	Grab	1/Year	2
Remaining Priority Pollutants ⁴	µg/L	Composite or Grab as appropriate	1/Year	2

C. Monitoring Location EFF-012, EFF-013, and EFF-014

Table E-2c. Effluent Monitoring - EFF-012, EFF-013, and EFF-014

Parameter	Units	Sample Type	Minimum Sampling Frequency ¹	Required Analytical Test Method
Rainfall	inches	Continuous	continuous	2
Hardness as CaCO ₃	mg/L	Composite	1/Year	2
pH	s.u.	Grab	1/Year ¹⁴	2
Temperature	°F	Grab	1/Year ¹⁴	2
Suspended solids	mg/L	Composite	1/Year ¹⁴	2

Parameter	Units	Sample Type	Minimum Sampling Frequency ¹	Required Analytical Test Method
BOD ₅ 20°C	mg/L	Composite	1/Year ¹⁴	²
Settleable solids	ml/L	Grab	1/Year ¹⁴	²
Oil and grease	mg/L	Grab	1/Year ¹⁴	²
Ammonia-N ³	mg/L	Composite	1/Year ¹⁴	²
Nitrate-N	mg/L	Composite	1/Year ¹⁴	²
Nitrite-N	mg/L	Composite	1/Year ¹⁴	²
Turbidity	NTU	Composite	1/Year ¹⁴	²
Total dissolved solids	mg/L	Composite	1/Year ¹⁴	²
Total petroleum hydrocarbons ⁹	µg/L	Grab	1/Year ¹⁴	²
Perchlorate	µg/L	Composite	1/Year ¹⁴	²
N-Nitrosodimethylamine	µg/L	Composite	1/Year ¹⁴	²
1,4-Dioxane	µg/L	Composite	1/Year ¹⁴	²
1,2,3-Trichloropropane	µg/L	Grab	1/Year ¹⁴	²
Ethylene dibromide	µg/L	Grab	1/Year ¹⁴	²
Methyl tertiary butyl ether (MTBE)	µg/L	Grab	1/Year ¹⁴	²
Naphthalene	µg/L	Composite	1/Year ¹⁴	²
Di-isopropyl Ether (DIPE)	µg/L	Grab	1/Year ¹⁴	²
Tertiary Butyl Alcohol (TBA)	µg/L	Grab	1/Year ¹⁴	²
Monomethyl hydrazine ¹⁰	µg/L	Grab	1/Year ¹⁴	²
Chloride	mg/L	Composite	1/Year ¹⁴	²
Boron	mg/L	Composite	1/Year ¹⁴	²
Sulfate	mg/L	Composite	1/Year ¹⁴	²
Fluoride	mg/L	Composite	1/Year ¹⁴	²
Nitrate + Nitrite-N	mg/L	Composite	1/Year ¹⁴	²
Copper, Total Recoverable	µg/L	Composite	1/Year ¹⁴	²
Lead, Total Recoverable	µg/L	Composite	1/Year ¹⁴	²
Mercury, Total Recoverable	µg/L	Composite	1/Year ¹⁴	²
Cadmium, Total Recoverable	µg/L	Composite	1/Year ¹⁴	²
Selenium, Total Recoverable	µg/L	Composite	1/Year ¹⁴	²
Zinc, Total Recoverable	µg/L	Composite	1/Year ¹⁴	²
TCDD ¹¹	µg/L	Composite	1/Year ¹⁴	²
Acute toxicity	% survival	Composite	1/Year	^{2, 5}
Chronic toxicity	TUc	Composite	1 st and 2 nd rain events of each year	²
Remaining USEPA priority pollutants excluding asbestos ⁴	µg/L	Composite or Grab as appropriate	1/Year	²

D. Monitoring Location EFF-019 – The Groundwater Treatment System

Table E-2d Effluent Monitoring - EFF-019

Parameter	Units	Sample Type	Minimum Sampling Frequency	Required Analytical Test Method
Flow	gpd (gallons per day)	Measure	Continuous	--
Biochemical Oxygen Demand (BOD)(5-day @20 Deg. C)	mg/L	Composite	1/Month	2
Temperature	°F	Grab	1/Month	2
Oil and Grease	mg/L	Grab	1/Month	2
Conductivity at 25 °C	µmhos/cm	Grab	1/Quarter	
pH	s.u.	Grab	1/Month	2
Total Suspended Solids (TSS)	mg/L	Composite	1/Month	2
Total organic carbon	mg/L	Composite	1/Month	2
Hardness (as mg/L CaCO ₃)	mg/L	Composite	1/Quarter	2
Detergents (as MBAS)	mg/L	Composite	1/Month	2
Cyanide, Total Recoverable	µg/L	Composite	1/Month	2
Cadmium, Total Recoverable	µg/L	Composite	1/Month	2
Copper, Total Recoverable	µg/L	Composite	1/Month	2
Lead, Total Recoverable	µg/L	Composite	1/Month	2
Mercury, Total Recoverable	µg/L	Composite	1/Month	2
Zinc, Total Recoverable	µg/L	Composite	1/Month	2
1,1-Dichloroethylene	µg/L	Grab	1/Month	2
Perchlorate	µg/L	Composite	1/Month	2
2,4,6-Trichlorophenol	µg/L	Composite	1/Month	2
2,4-Dinitrotoluene	µg/L	Composite	1/Month	2
Alpha-BHC	µg/L	Composite	1/Month	2
Bis(2-ethylhexyl)phthalate	µg/L	Composite	1/Month	2
N-Nitrosodimethylamine	µg/L	Composite	1/Month	2
Pentachlorophenol	µg/L	Composite	1/Month	2
Trichloroethylene	µg/L	Grab	1/Month	2
TCDD ¹¹	µg/L	Composite	1/Month	2
Volatile organic compounds	µg/L	Grab	1/Month	2
Boron	mg/L	Composite	1/Year ¹⁴	2
Fluoride	mg/L	Composite	1/Year ¹⁴	2
Barium	mg/L	Composite	1/Year ¹⁴	2
Iron	mg/L	Composite	1/Year ¹⁴	2
Manganese, Total Recoverable	µg/L	Composite	1/Year ¹⁴	2
Antimony, Total Recoverable	µg/L	Composite	1/Year ¹⁴	2
Arsenic, Total Recoverable	µg/L	Composite	1/Year ¹⁴	2

Parameter	Units	Sample Type	Minimum Sampling Frequency	Required Analytical Test Method
Beryllium, Total Recoverable	µg/L	Composite	1/Year ¹⁴	2
Chromium VI ⁸ , Total Recoverable	µg/L	Composite	1/Year ¹⁴	2
Nickel, Total Recoverable	µg/L	Composite	1/Year ¹⁴	2
Selenium, Total Recoverable	µg/L	Composite	1/Month	2
Silver, Total Recoverable	µg/L	Composite	1/Year ¹⁴	2
Thallium, Total Recoverable	µg/L	Composite	1/Year ¹⁴	2
Cobalt	µg/L	Composite	1/Year	2
Vanadium	µg/L	Composite	1/Year	2
Ammonia – N ³	mg/L	Composite	1/Month	2
Nitrate + Nitrite-N	mg/L	Composite	1/Month	2
Nitrate – N	mg/L	Composite	1/Month	2
Nitrite – N	mg/L	Composite	1/Month	2
Chloride	mg/L	Composite	1/Month	2
Chlorine, Total Residual	mg/L	Grab	1/Year	2
Dissolved Oxygen	mg/L	Grab	1/Month	2
Settleable Solids	ml/L	Grab	1/Month	2
Sulfate	mg/L	Composite	1/Month	2
Temperature	°F	Grab	1/Month	2
Total Dissolved Solids	mg/L	Composite	1/Month	2
Fecal coliform	(MPN per 100 mL)	Grab	1/Year	2
E. coli	(MPN per 100 mL)	Grab	1/Year	2
Toxicity, Acute	% survival	Composite	1/Quarter	2, 5
Toxicity, Chronic	TUc	Composite	2/Year	2
Turbidity	NTU	Composite	1/Month	2
Radioactivity- Gross Alpha Gross Beta	pCi/L pCi/L	Composite Composite	1/Month 1/Month	2,6,7
Combined Radium 226 & Radium 228 ⁷	pCi/L	Composite	1/Month	2,6,7
Tritium	pCi/L	Composite	1/Month	2,6,7
Strontium-90	pCi/L	Composite	1/Month	2,6,7
K-40 (Potassium-40)	pCi/L	Composite	1/Month	2,6,7
CS-137	pCi/L	Composite	1/Month	2,6,7
Uranium	pCi/L	Composite	1/Month	2,6,7
PCBs	µg/L	Grab	1/Year	2
TPH ⁹	µg/L	Grab	1/Year ¹⁴	2
Monomethyl hydrazine	µg/L	Grab	1/Year	2
cis-1,2-Dichloroethene	µg/L	Grab	1/Month	2

Parameter	Units	Sample Type	Minimum Sampling Frequency	Required Analytical Test Method
1,4-Dioxane	µg/L	Composite	1/Year ¹⁴	2
1,1,2-Trichloro-1,2,2-trifluoroethane	µg/L	Composite	1/Quarter	2
1,2-Dichloro-1,1,2-trifluoroethane	µg/L	Composite	1/Year	2
Cyclohexane	µg/L	Grab	1/Year	2
Remaining Priority Pollutants ⁴ excluding asbestos	µg/L	Composite or Grab as appropriate	1/Year	2

1. During wet weather flow, a discharge event is greater than 0.1 inch of rainfall in a 24-hour period. No more than one sample per week need be obtained during extended periods of rainfall and a storm must be preceded by at least 72 hours of dry weather. Sampling shall be during the first hour of discharge or at the first safe opportunity. The reason for delay shall be included in the report. If the rain event is not sufficient to produce flow from the area, the observation must be documented with date, time condition and rainfall amount. During dry weather flow, whenever Outfalls 001, 002, 011, 018, or 019 is discharging, minimum sampling frequency during operations generating discharges shall be once per month.
2. Pollutants shall be analyzed using the analytical methods described in 40 CFR Part 136; for Priority Pollutants the methods must meet the lowest minimum levels (MLs) specified in Attachment 4 of the SIP, provided as Attachment H. Where no methods are specified for a given pollutant, the methods must be approved by this Regional Water Board or the State Water Board.
3. The thirty day average at pH = 7.9 and 20°C, when hourly samples are collected and composited or only one grab sample is collected. The one hour average WLA at 7.9 pH and 20°C, applies if hourly samples are taken throughout the storm and each is analyzed. No single sample may exceed the 10.1 mg/L limit. Analysis for the temperature and pH of the receiving water at the same time as the discharge would provide data for a site-specific determination of the ammonia limit using Attachment H to the WDR. Shall there be no receiving water present, the pH and temperature of the effluent at the monitoring location shall be determined and reported.
4. Priority Pollutants as defined by the CTR defined in Finding II.I of the Limitations and Discharge Requirements of this Order, and included as Attachment I. Analysis shall include xylenes and trichlorofluoromethane. Analysis at 008 and 009 shall include asbestos.
5. Refer to section V., Whole Effluent Toxicity Testing Requirements.
6. Analyze these radiochemicals by the following USEPA testing methods: method 900.0 for gross alpha and gross beta, method 903.0 or 903.1 for radium-226, method 904.0 for radium-228, method 906.0 for tritium, method 908.0 for uranium, method 901.0 or 901.1 for Cesium, and method 905.0 for strontium-90.
7. Gross alpha and gross beta analysis must be performed. Gross alpha analysis must be ≤15 pCi/L. If gross alpha is >15 pCi/L, uranium analysis must be performed and must be less than 30 µg/L (20 pCi/L). Compliance with the permit shall then be based on comparing gross alpha minus total uranium to the gross alpha limit of 15 pCi/L. Radium-226 and radium-228 analysis must be performed, and combined Radium-226 and Ra-228 activity must be ≤ 5pCi/L. If gross alpha is <5 pCi/L, one can assume Ra-226 activity = gross alpha activity for purposes of meeting the 5 pCi/L limit.

Gross Beta, H-3, K-40, and Sr-90 analyses must be performed. Gross beta analysis must be ≤50 pCi/L. However, if gross beta is >50 pCi/L, compliance with the Permit shall be based on comparing gross beta minus K-40 to the ≤50 pCi/L gross beta limitation. The gross beta limit is 50 pCi/L, after subtraction of K-40 activity. The K-40 is assumed to be all natural. The H-3 limit is 20,000 pCi/L, and the Sr-90 limit is 8 pCi/L. If gross beta >50 pCi/L (after subtracting K-40 activity) gamma isotopic analysis must be performed for Cs-137 (the most likely emitter associated with the site). The sum of the fractions technique must be used to demonstrate that the gamma emitters don't exceed 4 mrem/year (200 pCi/L for Cs-137). The sum of the fractions must include H-3 and Sr-90. If the limit is exceeded, which is an annual average, the frequency of the sampling is increased to once per discharge event until the annual average is below the specified limit. If the analyses of these constituents demonstrates exceedances, of the annual average effluent limitations (determined at each sampling point) the monitoring frequency is increased to once per discharge until four consecutive analyses demonstrates compliance with the effluent limitations.

8. The Discharger has the option to meet the hexavalent chromium limitations with a total chromium analysis. However, if the total chromium level exceeds the hexavalent chromium limitation it will be considered a violation unless an analysis has been made for hexavalent chromium in a replicate sample and the result is reported within the hexavalent chromium limits.
9. Total petroleum hydrocarbons include all fuels, gasoline, diesel, and jet fuel. Analysis should be completed using EPA 8015 (modified) methods. If the results exceeds the criteria then the monitoring frequency must be increased from monthly to weekly at Outfall 019 or as directed by Regional Water Board Executive Officer for outfalls that are not currently monitored once per discharge event.
10. This analysis is completed only for discharges from APTF at Outfall 014.
11. Discharger must monitor the effluent for the presence of the 17 congeners of 2,3,7,8-TCDD listed below. To determining compliance with effluent limits or for conduction of Reasonable Potential Analysis, this Order requires the Discharger to calculate and report dioxin-toxicity equivalencies (TEQs) using the following formula, where the toxicity equivalency factors (TEFs) and bioaccumulation equivalency factor (BEF) are as listed in Table below:

$$\text{Dioxin-TEQ} = \sum(C_x \times \text{TEF}_x \times \text{BEF}_x)$$

Table: Toxicity Equivalency Factors and Bioaccumulation Equivalency Factors

Dioxin or Furan Congener	Toxicity Equivalency Factor (TEF)	Bioaccumulation Equivalency Factor (BEF)
2,3,7,8-tetra CDD	1.0	1.0
1,2,3,7,8-penta CDD	1.0	0.9
1,2,3,4,7,8-hexa CDD	0.1	0.3
1,2,3,6,7,8-hexa CDD	0.1	0.1
1,2,3,7,8,9-hexa CDD	0.1	0.1
1,2,3,4,6,7,8-hepta CDD	0.01	0.05
Octa CDD	0.0001	0.01
2,3,7,8-tetra CDF	0.1	0.8
1,2,3,7,8-penta CDF	0.05	0.2
2,3,4,7,8-penta CDF	0.5	1.6

Dioxin or Furan Congener	Toxicity Equivalency Factor (TEF)	Bioaccumulation Equivalency Factor (BEF)
1,2,3,4,7,8-hexa CDF	0.1	0.08
1,2,3,6,7,8-hexa CDF	0.1	0.2
1,2,3,7,8,9-hexa CDF	0.1	0.6
2,3,4,6,7,8-hexa CDF	0.1	0.7
1,2,3,4,6,7,8-hepta CDF	0.01	0.01
1,2,3,4,7,8,9-hepta CDF	0.01	0.4
Octa CDF	0.0001	0.02

where:

C_x = concentration of dioxin or furan congener x
 TEF_x = TEF for congener x
 BEF_x = BEF for congener x

12. Once per discharge event at Outfall 008 only. Semiannually at all other storm water only outfalls. If the results are non detect for two years the Discharger may submit a request for the monitoring frequency to be decreased to annually with Executive Officer approval.
13. Analyzed for Outfall 008 only
14. If the detected concentration exceeds the criteria, the frequency of analysis must be increased to once per discharge (once per month at Outfall 019). After four consecutive samplings demonstrate compliance, then the frequency reverts back to annual sampling.

V. WHOLE EFFLUENT TOXICITY TESTING REQUIREMENTS

A. Definition of Toxicity

2. Acute Toxicity.

Acute toxicity is a measure of primarily lethal effects that occur over a 96-hour period. Acute toxicity shall be measured in percent survival measured in undiluted (100%) effluent.

- (a) The average survival in the undiluted effluent for any three (3) consecutive 96-hour static or continuous flow bioassay tests shall be at least 90%, and
- (b) No single test shall produce less than 70% survival.

3. Chronic Toxicity.

Chronic toxicity measures a sublethal effect (e.g., reduced growth, reproduction) to experimental test organisms exposed to an effluent or ambient waters compared to that of the control organisms. Chronic toxicity shall be measured in TU_c , where $TU_c = 100/NOEC$. The No Observable Effect Concentration (NOEC) is expressed as the maximum percent effluent concentration that causes no observable effect on test organisms, as determined by the results of a critical life stage toxicity test.

This Order includes a chronic testing toxicity trigger defined as an exceedance of 1.0 TU_c in a critical life stage test of 100% effluent. (The monthly median for chronic toxicity of 100% effluent shall not exceed, 1 TU_c in a critical life stage test.)

4. Accelerated Monitoring

If either of the above requirements is not met, the Discharger shall conduct six additional tests over a 6-week period, if possible. The Discharger shall ensure that they receive results of a failing toxicity test within 24 hours of the close of the test and the additional tests shall begin within 3 business days of the receipt of the result. If the additional tests indicate compliance with the toxicity limitation, the Discharger may resume regular testing. However, if the results of any two of the six accelerated tests are less than the stipulated requirements, then the Discharger shall begin a Toxicity Identification Evaluation (TIE). The TIE shall include all reasonable steps to identify the sources of toxicity. Once the sources are identified, the Discharger shall take all reasonable steps to reduce toxicity to meet the objective.

If the initial test and any of the additional six acute toxicity bioassay tests result in less than 70% survival, including the initial test, the Discharger shall immediately begin a TIE.

B. Acute Toxicity Effluent Monitoring Program

1. Method. The Discharger shall conduct acute toxicity tests on 24-hour composite 100% effluent samples by methods specified in Part 136 which cites USEPA's *Methods for Measuring the Acute Toxicity of Effluents and Receiving Waters to Freshwater and Marine Organisms*, Fifth Edition, October 2002, USEPA, Office of Water, Washington D.C. (EPA-821-R-02-012) or a more recent edition to ensure compliance. Effluent samples shall be collected after all treatment processes and before discharge to the receiving water.
2. Test species. The fathead minnow, *Pimephales promelas*, (Acute Toxicity Test Method 2000.0) shall be used as the test species for fresh water discharges and the topsmelt, *Atherinops affinis*, shall be used as the test species for brackish effluent. However, if the salinity of the receiving water is between 1 to 32 parts per thousand (ppt), the Discharger may have the option of using the inland silverside, *Menidia beryllina* (Acute Toxicity Test Method 2006.0), instead of the topsmelt. The method for topsmelt (Larval Survival and Growth Test Method 1006.0) is found in USEPA's *Short-term Method for Estimating the Chronic Toxicity of Effluents and Receiving Waters to Fresh Water Organisms*, Fourth Edition, October 2002 (EPA-821-02-013).
3. In lieu of conducting the standard acute toxicity testing with the fathead minnow, the Discharger may elect to report the results or endpoint from the first 96 hours of the chronic toxicity test as the results of the acute toxicity test.
4. Effluent samples shall be collected after all treatment processes and before discharge to the receiving water.

C. Chronic Toxicity Effluent Monitoring Program

1. The Discharger shall conduct critical life stage chronic toxicity tests on effluent samples (24-hour composite) 100% effluent or receiving water samples. For freshwater discharge the analysis is completed in accordance with EPA's *Short-Term Methods for Estimating the Chronic Toxicity of Effluents and Receiving Waters to Freshwater Organisms*, Fourth Edition, October 2002 (EPA/821-R-02-013) or a more recent edition. For brackish effluent, the Discharger shall conduct the chronic toxicity test in accordance with USEPA's *Short-term Methods for Estimating the Chronic Toxicity of Effluent and Receiving Waters to West Coast Marine and Estuarine Organisms*, First Edition, August 1995 (EPA/600/R-95/136) or *Short Term Methods for Estimating the Chronic Toxicity of Effluents and Receiving Waters to Marine and Estuarine Organisms*, Third Edition, October 2002, (EPA/821-R-02-014) or a more recent edition.
2. The Discharger shall conduct tests as follows: with a vertebrate, an invertebrate, and an alga (plant) for the first three suites of tests. After the screening period, monitoring shall be conducted using the most sensitive species.

3. Re-screening is required every 24 months. The Discharger shall re-screen with the three species listed above and continue to monitor with the most sensitive species. If the first suite of re-screening tests demonstrates that the same species is the most sensitive than the re-screening does not need to include more than one suite of tests. If a different species is the most sensitive or if there is ambiguity then the Discharger shall proceed with suites of screening tests for a minimum of three, but not to exceed five suites.
4. The presence of chronic toxicity shall be estimated as specified using West Coast marine organisms according to EPA's Short-Term Methods for Estimating Chronic Toxicity of Effluent and Receiving Waters to Freshwater Organisms, Fourth Edition, October 2002 (EPA/821-R-02-013).
5. In brackish waters, the presence of chronic toxicity may be estimated as specified using West Coast marine organisms according to USEPA's *Short-Term Methods for Estimating Chronic Toxicity of Effluent and Receiving Waters to West Coast Marine and Estuarine Organisms*, August 1995 (EPA/600/R-95/136), or a more recent edition.
6. After the screening period, monitoring shall be conducted quarterly using the most sensitive species.
7. Effluent samples shall be collected after all treatment processes and before discharge to the receiving water.

D. Quality Assurance

1. Concurrent testing with a reference toxicant shall be conducted. Reference toxicant tests shall be conducted using the same test conditions as the effluent toxicity tests (e.g., same test duration, etc).
2. If either the reference toxicant test or effluent test does not meet all test acceptability criteria (TAC) as specified in the test methods manuals (EPA/600/4-91/002 and EPA/821-R-02-014), then the Discharger must re-sample and re-test at the earliest time possible.
3. Control and dilution water should be receiving water or laboratory water, as appropriate, as described in the manual. If the dilution water used is different from the culture water, a second control using culture water shall be used.

E. Accelerated Monitoring and Initial Investigation TRE Trigger

1. If toxicity exceeds the limitations (as defined below in sections V.A.1 and V.A.2, above), then the Discharger shall immediately implement accelerated testing, as specified at section V.A.3, above. The Discharger shall ensure that they receive results of a failing toxicity test within 24 hours of the completion of the test and the

additional tests shall begin within 3 business days of the receipt of the results or at the first opportunity of discharge. If the accelerated testing shows consistent toxicity, the Discharger shall immediately implement the Initial Investigation of the TRE Workplan.

2. If implementation of the Initial Investigation TRE Workplan indicates the source of toxicity (e.g., a temporary plant upset, etc.), then the Discharger may discontinue the TIE.
3. The first step in the Initial Investigation TRE Workplan for downstream receiving water toxicity can be a toxicity test protocol designed to determine if the effluent causes or contributes to the measured downstream toxicity. If this first step TRE testing shows that the outfall effluent does not cause or contribute to downstream toxicity, using USEPA's *Short-Term Methods for Estimating the Chronic Toxicity of Effluents and Receiving Waters to Marine and Estuarine Organisms*, Fourth Edition, October 2002, USEPA, Office of Water, Washington D.C. (EPA/821-R-02-014) then a report on this testing shall be submitted to the Regional Water Board and the TRE will be considered to be completed. Routine testing in accordance with the MRP shall be continued thereafter.

F. Toxicity Reduction Evaluation (TRE)/ Toxicity Identification Evaluation (TIE) Trigger

1. If the accelerated testing shows consistent toxicity as defined below:
 - i. Acute Toxicity:
 1. If the results of any two of the six accelerated tests are less than 90% survival, or
 2. If the initial test and any of the additional six acute toxicity bioassay tests result in less than 70% survival
 - ii. Chronic Toxicity:
 1. If the results of two of the six accelerated tests exceed 1.0 TU_c.

then, the Discharger shall immediately implement the Toxicity Reduction Evaluation (TRE) as described below.

G. Steps in TRE and TIE Procedures

1. Following a TRE trigger, the Discharger shall initiate a TRE in accordance with the facility's Initial Investigation TRE workplan. At a minimum, the Discharger shall use USEPA manuals EPA/600/2-88/070 (industrial) or EPA/833B-99/002 (municipal) as guidance. The Discharger shall expeditiously develop a more detailed TRE

workplan for submittal to the Executive Officer within 30 days of the trigger, which will include, but not be limited to:

- i. Further actions to investigate and identify the cause of toxicity;
- ii. Actions the Discharger will take to mitigate the impact of the discharge and prevent the recurrence of toxicity;
- iii. Standards the Discharger will apply to consider the TRE complete and to return to normal sampling frequency; and,
- iv. A schedule for these actions.

2. The following is a stepwise approach in conducting the TRE

- i. Step 1 - Basic data collection. Data collected for the accelerated monitoring requirements may be used to conduct the TRE;
- ii. Step 2 - Evaluates optimization of the treatment system operation, facility housekeeping, and the selection and use of in-plant process chemicals;
- iii. Step 3 – If Steps 1 and 2 are unsuccessful, Step 3 implements a Toxicity Identification Evaluation (TIE) by employing all reasonable efforts and using currently available TIE methodologies. The Discharger shall use the USEPA acute and chronic manuals, EPA/600/6-91/005F (Phase I)/EPA/600/R-96-054 (for marine), EPA/600/R-92/080 (Phase II), and EPA-600/R-92/081 (Phase III) as guidance. The objective of the TIE is to identify the substance or combination of substances causing the observed toxicity;
- iv. Step 4 – Assuming successful identification or characterization of the toxicant(s), Step 4 evaluates final effluent treatment options;
- v. Step 5 evaluates in-plant treatment options; and,
- vi. Step 6 consists of confirmation once a toxicity control method has been implemented.

Many recommended TRE elements parallel source control, pollution prevention, and storm water control program best management practices (BMPs). To prevent duplication of efforts, evidence of implementation of these control measures may be sufficient to comply with TRE requirements. By requiring the first steps of a TRE to be accelerated testing and review of the facility's TRE workplan, a TRE may be ended in its early stages. All reasonable steps shall be taken to reduce toxicity to the required level. The TRE may be ended at any stage if monitoring indicates there is no longer toxicity (or six consecutive acute toxicity test results are greater than 90% survival).

3. If a TRE/TIE is initiated prior to completion of the accelerated testing schedule required by this permit, then the accelerated testing schedule may be terminated, or used as necessary in performing the TRE/TIE, as determined by the Executive Officer.
4. Toxicity tests conducted as part of a TRE/TIE may also be used for compliance determination, if appropriate.
5. The Regional Water Board recognizes that toxicity may be episodic and identification of causes of and reduction of sources of toxicity may not be successful in all cases. Consideration of enforcement action by the Regional Water Board will be based in part on the Discharger's actions and efforts to identify and control or reduce sources of consistent toxicity.

H. Ammonia Removal

1. Except with prior approval from the Executive Officer of the Regional Water Board, ammonia shall not be removed from bioassay samples. The Discharger must demonstrate the effluent toxicity is caused by ammonia *because of* increasing test pH when conducting the toxicity test. It is important to distinguish the potential toxic effects of ammonia from other pH sensitive chemicals, such as certain heavy metals, sulfide, and cyanide. The following may be steps to demonstrate that the toxicity is caused by ammonia and not other toxicants before the Executive Officer would allow for control of pH in the test.
 - a. There is consistent toxicity in the effluent and the maximum pH in the toxicity test is in the range to cause toxicity due to increased pH.
 - b. Chronic ammonia concentrations in the effluent are greater than 4 mg/L total ammonia.
 - c. Conduct graduated pH tests as specified in the toxicity identification evaluation methods. For example, mortality should be higher at pH 8 and lower at pH 6.
 - d. Treat the effluent with a zeolite column to remove ammonia. Mortality in the zeolite treated effluent should be lower than the non-zeolite treated effluent. Then add ammonia back to the zeolite-treated samples to confirm toxicity due to ammonia.
3. When it has been demonstrated that toxicity is due to ammonia because of increasing test pH, pH may be controlled using appropriate procedures which do not significantly alter the nature of the effluent, after submitting a written request to the Regional Water Board, and receiving written permission expressing approval from the Executive Officer of the Regional Water Board.

I. Reporting

1. The Discharger shall submit a full report of the toxicity test results, including any accelerated testing conducted during the month as required by this permit. Test results shall be reported as % survival for acute toxicity test results with the self monitoring reports (SMR) for the month in which the test is conducted.
2. If an initial investigation indicates the source of toxicity and accelerated testing is unnecessary, then those results also shall be submitted with the SMR for the period in which the investigation occurred.
 - i. The full report shall be submitted on or before the end of the month in which the SMR is submitted.
 - ii. The full report shall consist of (1) the results; (2) the dates of sample collection and initiation of each toxicity test; (3) the acute toxicity average limit and (4) printout of the ToxCalc or CETIS program results.
3. Test results for toxicity tests also shall be reported according to the appropriate manual chapter on Report Preparation and shall be attached to the SMR. Routine reporting shall include, at a minimum, as applicable, for each test:
 - i. Sample date(s);
 - ii. Test initiation date;
 - iii. Test species;
 - iv. End point values for each dilution (e.g., number of young, growth rate, percent survival);
 - v. NOEC value(s) in percent effluent;
 - vi. IC₁₅, IC₂₅, IC₄₀ and IC₅₀ values in percent effluent;
 - vii. TU_c values $\left(TU_c = \frac{100}{NOEC} \right)$;
 - viii. Mean percent mortality (+standard deviation) after 96 hours in 100% effluent (if applicable);
 - ix. NOEC and LOEC values for reference toxicant test(s);
 - x. IC₂₅ value for reference toxicant test(s);

- xi. Any applicable charts; and
 - xii. Available water quality measurements for each test (e.g., pH, D.O., temperature, conductivity, hardness, salinity, ammonia).
4. The Discharger shall provide a compliance summary, which includes a summary table of toxicity data from all samples collected during that year.

The Discharger shall notify by telephone or electronically, this Regional Water Board of any toxicity exceedance of the limit or trigger within 24 hours of receipt of the results followed by a written report within 14 calendar days of receipt of the results. The verbal or electronic notification shall include the exceedance and the plan the Discharger has taken or will take to investigate and correct the cause(s) of toxicity. It may also include a status report on any actions required by the permit, with a schedule for actions not yet completed. If no actions have been taken, the reasons shall be given.

VI. LAND DISCHARGE MONITORING REQUIREMENTS

Not applicable

VII. RECLAMATION MONITORING REQUIREMENTS

Not applicable

VIII. RECEIVING WATER MONITORING REQUIREMENTS – SURFACE WATER

A. Monitoring Locations RSW-001 (Bell Creek) and RSW-002 (Arroyo Simi).

Table E-3. Receiving Water Monitoring Requirements – RSW-001 and RSW-002

Parameter	Units	Sample Type	Minimum Sampling Frequency	Required Analytical Test Method
Water velocity	Ft/second	Recorder	1/Quarter	1
pH	s.u.	grab	1/Quarter	1,2
Hardness (as mg/L CaCO ₃)	mg/L	grab	1/Quarter	1,2
TSS	mg/L	grab	1/Year	1,2
Fecal coliform ⁵	(MPN per 100 mL)	grab	1/Year	1
E. coli ⁵	(MPN per 100 mL)	grab	1/Year	1
Temperature	°F	grab	1/Quarter ³	1
TCDD – Equivalents ⁴	µg/L	grab	1/Year	1
Chlorpyrifos	µg/L	grab	1/Quarter ³	1
Diazinon	µg/L	grab	1/Quarter ³	1
Chlordane	µg/L	grab	1/Quarter ³	1

Parameter	Units	Sample Type	Minimum Sampling Frequency	Required Analytical Test Method
4,4-DDD	µg/L	grab	1/Quarter ³	1
4,4-DDE	µg/L	grab	1/Quarter ³	1
4,4-DDT	µg/L	grab	1/Quarter ³	1
Dieldrin	µg/L	grab	1/Quarter ³	1
PCBs	µg/L	grab	1/Quarter ³	1
Toxaphene	µg/L	grab	1/Quarter ³	1
Priority Pollutants	µg/L	grab	Once every five years	1,2

1. Pollutants shall be analyzed using the analytical methods described in 40 CFR Part 136; for Priority Pollutants the methods must meet the lowest minimum levels (MLs) specified in Attachment 4 of the SIP, provided as Attachment H. Where no methods are specified for a given pollutant, the methods must be approved by this Regional Water Board or the State Board.
2. Receiving water samples for pH, hardness, and priority pollutants must be collected at the same time as effluent samples.
3. Samples are collected quarterly. The final concentration is the average of the samples collected over one year. Compliance is determined by comparing the final concentration limits listed in Section V of Order R4-2010-0090.
4. The Discharger must monitor the receiving water for the presence of the 17 congeners of 2,3,7,8-TCDD listed below. To determine compliance with effluent limits or for conduction of Reasonable Potential Analysis, this Order requires the Discharger to calculate and report dioxin-toxicity equivalencies (TEQs) using the following formula, where the toxicity equivalency factors (TEFs) and bioaccumulation equivalency factor (BEF). BEFs are as listed in Table below:

$$\text{Dioxin-TEQ} = (C_x \times \text{TEF}_x \times \text{BEF}_x)$$

Table: Toxicity Equivalency Factors and Bioaccumulation Equivalency Factors

Dioxin or Furan Congener	Toxicity Equivalency Factor (TEF)	Bioaccumulation Equivalency Factor (BEF)
2,3,7,8-tetra CDD	1.0	1.0
1,2,3,7,8-penta CDD	1.0	0.9
1,2,3,4,7,8-hexa CDD	0.1	0.3
1,2,3,6,7,8-hexa CDD	0.1	0.1
1,2,3,7,8,9-hexa CDD	0.1	0.1
1,2,3,4,6,7,8-hepta CDD	0.01	0.05
Octa CDD	0.0001	0.01
2,3,7,8-tetra CDF	0.1	0.8
1,2,3,7,8-penta CDF	0.05	0.2
2,3,4,7,8-penta CDF	0.5	1.6
1,2,3,4,7,8-hexa CDF	0.1	0.08
1,2,3,6,7,8-hexa CDF	0.1	0.2

Dioxin or Furan Congener	Toxicity Equivalency Factor (TEF)	Bioaccumulation Equivalency Factor (BEF)
1,2,3,7,8,9-hexa CDF	0.1	0.6
2,3,4,6,7,8-hexa CDF	0.1	0.7
1,2,3,4,6,7,8-hepta CDF	0.01	0.01
1,2,3,4,7,8,9-hepta CDF	0.01	0.4
Octa CDF	0.0001	0.02

where:

C_x = concentration of dioxin or furan congener x
 TEF_x = TEF for congener x
 BEF_x = BEF for congener x

5 Bacterial Limitations

1. Geometric Mean Limits:

- a. E. coli density shall not exceed 126/100 ml.
- b. Fecal coliform density shall not exceed 200/100 ml

2. Single Sample Maximum Limits:

- a. E. coli density shall not exceed 235/100 ml.
- b. Fecal coliform density shall not exceed 400/100 ml.

The geometric mean values should be calculated based on a statistically sufficient number of samples (generally not less than 5 samples equally spaced over a 30-day period, if possible).

If any of the single sample limits are exceeded, the Regional Water Board requires repeat sampling on a daily basis until the sample falls below the single sample limit in order to determine the persistence of the exceedance.

When repeat sampling is required because of an exceedance of any one single sample limit, values from all samples collected during that 30-day period shall be used to calculate the geometric mean.

B. Receiving Water Surveys

The receiving water monitoring program shall include periodic surveys of Bell Creek, Dayton Canyon Creek and the Arroyo Simi and shall include studies of those physical-chemical characteristics of the receiving water that may be impacted by the discharge.

Receiving Water Observations. General observations of the receiving water shall be made at each discharge point on a monthly basis (only during discharge from any of the respective Outfalls) and shall be reported in the quarterly monitoring report.

Observations shall be descriptive where applicable, such that colors, approximate amounts, or types of materials that are apparent are enumerated. The following observations shall be made.

- Tidal stage, time, and date of monitoring
- Weather conditions
- Color of water
- Appearance of oil films or grease, or floatable materials
- Extent of visible turbidity or color patches
- Direction of tidal flow
- Description of odor, if any, or the receiving water
- Presence and/or activity to California Least Tern or California Brown Pelican.

IX. SEDIMENT SAMPLING

The Calleguas Creek OC Pesticides and PCBs TMDL includes requirements for the concentrations of several pesticides and PCBs in sediment. Therefore this permit includes requirements to monitor sediment for these constituents. The Discharger may choose to join the Calleguas Creek Watershed TMDL Monitoring Program (CCWTMP) and collect the required sediment samples along with a host of other stakeholders in the watershed. This facility is located in Arroyo Simi and the Compliance Sampling Site locations stipulated in the TMDL documentation are Arroyo Simi East of Hitch Boulevard (07_HITCH) or Simi Valley Water Quality Control Plant (07D_SIMI). As an alternative the Discharger may choose to collect the sediment samples at the base of the subwatershed where the discharge occurs. The exact location of the sampling point must be stipulated in the initial self-monitoring report.

The in-stream sediment sampling shall be conducted according to methods developed by the USGS and outlined in *Guidelines for Collecting and Processing Samples of Stream Bed Sediment for Analysis of Trace Elements and Organic Contaminants for the National Water Quality Assessment Program* (1994). A brief description of the protocol also appears in the *Draft Calleguas Creek Watershed Management Plan Quality Assurance Project Plan (QAPP) Monitoring and Reporting Program Plan for Nitrogen, OC and PCBs, and Toxicity Total Maximum Daily Loads* dated September 26, 2006, beginning on page 38. Discussions include field measurements and observations, sample handling and custody, sample handling and shipping, and analytical methods.

Table E-3. Receiving Water Sediment Monitoring Requirements

Parameter	Units	Sample Type	Minimum Sampling Frequency
Sediment toxicity (chronic 10-day eohaustorius estuarius toxicity)	NA	Grab	1/Year
48-hour Bivalve Embryo toxicity (Mytilus edulis or Crassostrea gigas)	NA	Grab	1/Year
Total ammonia	Mg/wet kg	Grab	1/Year
% Moisture	%	Grab	1/Year
Particle Size Distribution	um	Grab	1/Year
Total Organic Carbon	% dry weight	Grab	1/Year
Water velocity	ft/sec	Grab	1/Year
pH	pH units	Grab	1/Year
Temperature	°C	Grab	1/Year
Dissolved Oxygen	mg/L	Grab	1/Year
Conductivity	µmhos/cm	Grab	1/Year
Chlordane	µg/g	Grab	1/Year
4,4-DDD	µg/g	Grab	1/Year
4,4-DDE	µg/g	Grab	1/Year
4,4-DDT	µg/g	Grab	1/Year
Dieldrin	µg/g	Grab	1/Year
PCBs	µg/g	Grab	1/Year
Toxaphene	µg/g	Grab	1/Year

X. BIOASSESSMENT MONITORING

1. The goals of the bioassessment monitoring for the Arroyo Simi and Los Angeles River are to:
 - Determine compliance with receiving water limits;
 - Monitor trends in surface water quality;
 - Ensure protection of beneficial uses;
 - Provide data for modeling contaminants of concern;
 - Characterize water quality including seasonal variation of surface waters within the watershed;
 - Assess the health of the biological community; and
 - Determine mixing dynamics of effluent and receiving waters in the estuary.

2. In coordination with interested stakeholders in the Calleguas Creek Watershed and within the Los Angeles River Watershed, the Discharger shall conduct instream bioassessment monitoring once a year, during the spring/summer period (unless an alternate sampling period is approved by the Executive Officer). Over time, bioassessment monitoring will provide a measure of the physical condition of the waterbody and the integrity of its biological communities.
 - a. The bioassessment program shall include an analysis of the community structure of the in stream macroinvertebrate assemblages and physical habitat assessment at the monitoring stations RSW-001U and RSW-002D. This program shall be implemented by appropriately trained staff. Alternatively, a professional subcontractor qualified to conduct bioassessments may be selected to perform the bioassessment work for the Discharger. Analyses of the results of the bioassessment monitoring program, along with photographs of the monitoring site locations taken during sample collection, shall be submitted in the corresponding annual report. If another stakeholder, or interested party in the watershed subcontracts a qualified professional to conduct bioassessment monitoring during the same season and at the same location as specified in the MRP, then the Discharger may, in lieu of duplicative sampling, submit the data, a report interpreting the data, photographs of the site, and related QA/QC documentation in the corresponding annual report.
 - b. The Discharger must provide a copy of their Standard Operation Procedures (SOPs) for the Bioassessment Monitoring Program to the Regional Water Board upon request. The document must contain step-by-step field, laboratory and data entry procedures, as well as, related QA/QC procedures. The SOP must also include specific information about each bioassessment program including: assessment program description, its organization and the responsibilities of all its personnel; assessment project description and objectives; qualifications of all personnel; and the type of training each member has received.
 - c. Field sampling must conform to the SOP established for the California Stream Bioassessment Procedure (CSBP) or more recently established sampling protocols, such as used by the Surface Water Ambient Monitoring Program (SWAMP). Field crews shall be trained on aspects of the protocol and appropriate safety issues. All field data and sample Chain of Custody (COC) forms must be examined for completion and gross errors. Field inspections shall be planned with random visits and shall be performed by the Discharger or an independent auditor. These visits shall report on all aspects of the field procedure with corrective action occurring immediately.
 - d. A taxonomic identification laboratory shall process the biological samples that usually consist of subsampling organisms, enumerating and identifying taxonomic groups and entering the information into an electronic format. The Regional Water Board may require QA/QC documents from the taxonomic laboratories and examine

their records regularly. Intra-laboratory QA/QC for subsampling, taxonomic validation and corrective actions shall be conducted and documented. Biological laboratories shall also maintain reference collections, vouchered specimens (the Discharger may request the return of their sample voucher collections) and remnant collections. The laboratory should participate in an (external) laboratory taxonomic validation program at a recommended level of 10% or 20%. External QA/QC may be arranged through the California Department of Fish and Game's Aquatic Bioassessment Laboratory located in Rancho Cordova, California.

- e. The Executive Officer of the Regional Water Board may modify the Monitoring and Reporting Program to accommodate the watershed-wide monitoring

XI. OTHER MONITORING REQUIREMENTS

A. SWPPP Status and Effectiveness Report

1. As required under Special Provision VI.C.3 of this Order, the Discharger shall submit an updated SWPPP to the Executive Officer of the Regional Water Board within 90 days of the effective date of this permit.
2. Annually the Discharger shall report the status of the implementation and the effectiveness of the SWPPP required under Special Provision VI.C.3 of this Order. The SWPPP shall be reviewed at a minimum once per year and updated as needed to ensure all actual or potential sources of pollutants in wastewater and storm water discharged from the Facility are addressed in the SWPPP Status and Effectiveness Report. All changes or revisions to the SWPPP Status and Effectiveness Report will be summarized in the annual report required under Attachment E, Monitoring and Reporting Section XII.A.

B. Chemical Use Report

XII. REPORTING REQUIREMENTS

A. General Monitoring and Reporting Requirements

1. The Discharger shall comply with all Standard Provisions (Attachment D) related to monitoring, reporting, and recordkeeping.
2. If there is no discharge during any reporting period, the report shall so state.
3. Each monitoring report shall contain a separate section titled "Summary of Non-Compliance" which discusses the compliance record and corrective actions taken or planned that may be needed to bring the discharge into full compliance with waste discharge requirements. This section shall clearly list all non-compliance with waste discharge requirements, as well as all excursions of effluent limitations.

4. The Discharger shall inform the Regional Water Board well in advance of any proposed construction activity that could potentially affect compliance with applicable requirements.
5. The Discharger shall report the results of acute toxicity testing, TRE and TIE as required in the Attachment E, Monitoring and Reporting, section V.G.

B. Self Monitoring Reports (SMRs)

1. At any time during the term of this permit, the State or Regional Water Board may notify the Discharger to electronically submit Self-Monitoring Reports (SMRs) using the State Water Board’s California Integrated Water Quality System (CIWQS) Program Web site (<http://www.waterboards.ca.gov/ciwqs/index.html>). Until such notification is given, the Discharger shall submit hard copy SMRs. The CIWQS Web site will provide additional directions for SMR submittal in the event there will be service interruption for electronic submittal.
2. The Discharger shall report in the SMR the results for all monitoring specified in this MRP under sections III through IX. The Discharger shall submit quarterly SMRs including the results of all required monitoring using USEPA-approved test methods or other test methods specified in this Order. If the Discharger monitors any pollutant more frequently than required by this Order, the results of this monitoring shall be included in the calculations and reporting of the data submitted in the SMR.
3. Monitoring periods and reporting for all required monitoring shall be completed according to the following schedule:

Table E-4. Monitoring Periods and Reporting Schedule

Sampling Frequency	Monitoring Period Begins On...	Monitoring Period	SMR Due Date
1/Discharge Event, 1/Month, and/or 1/Quarter	July 19, 2010	January 1 through March 31 April 1 through June 30 July 1 through September 30 October 1 through December 31	May 15 August 15 November 15 February 15
1/Year	July 19, 2010	January 1 through December 31	March 1

4. Reporting Protocols. The Discharger shall report with each sample result the applicable reported Minimum Level (ML) and the current Method Detection Limit (MDL), as determined by the procedure in Part 136.

The Discharger shall report the results of analytical determinations for the presence of chemical constituents in a sample using the following reporting protocols:

- a. Sample results greater than or equal to the reported ML shall be reported as measured by the laboratory (i.e., the measured chemical concentration in the sample).
- b. Sample results less than the RL, but greater than or equal to the laboratory's MDL, shall be reported as "Detected, but Not Quantified," or DNQ. The estimated chemical concentration of the sample shall also be reported.

For the purposes of data collection, the laboratory shall write the estimated chemical concentration next to DNQ as well as the words "Estimated Concentration" (may be shortened to "Est. Conc."). The laboratory may, if such information is available, include numerical estimates of the data quality for the reported result. Numerical estimates of data quality may be percent accuracy (+ a percentage of the reported value), numerical ranges (low to high), or any other means considered appropriate by the laboratory.

- d. Sample results less than the laboratory's MDL shall be reported as "Not Detected," or ND.
 - e. Dischargers are to instruct laboratories to establish calibration standards so that the ML value (or its equivalent if there is differential treatment of samples relative to calibration standards) is the lowest calibration standard. At no time is the Discharger to use analytical data derived from extrapolation beyond the lowest point of the calibration curve.
5. The Discharger shall submit SMRs in accordance with the following requirements:
- a. The Discharger shall arrange all reported data in a tabular format. The data shall be summarized to clearly illustrate whether the facility is operating in compliance with interim and/or final effluent limitations. The Discharger is not required to duplicate the submittal of data that is entered in a tabular format within CIWQS. When electronic submittal of data is required and CIWQS does not provide for entry into a tabular format within the system, the Discharger shall electronically submit the data in a tabular format as an attachment.
 - b. The Discharger shall attach a cover letter to the SMR. The information contained in the cover letter shall clearly identify violations of the WDRs; discuss corrective actions taken or planned; and the proposed time schedule for corrective actions. Identified violations must include a description of the requirement that was violated and a description of the violation.
 - c. SMRs must be submitted to the Regional Water Board, signed and certified as required by the Standard Provisions (Attachment D), to the address listed below:

**California Regional Water Quality Control Board
 Los Angeles Region
 320 W. 4th Street, Suite 200
 Los Angeles, Ca 90013**

C. Discharge Monitoring Reports (DMRs)

1. As described in section X.B.1 above, at any time during the term of this permit, the State or Regional Water Board may notify the Discharger to electronically submit SMRs that will satisfy federal requirements for submittal of Discharge Monitoring Reports (DMRs). Until such notification is given, the Discharger shall submit DMRs in accordance with the requirements described below. DMRs must be signed and certified as required by the standard provisions (Attachment D). The Discharger shall submit the original DMR and one copy of the DMR to the address listed below:

STANDARD MAIL	FEDEX/UPS/ OTHER PRIVATE CARRIERS
State Water Resources Control Board Division of Water Quality c/o DMR Processing Center PO Box 100 Sacramento, CA 95812-1000	State Water Resources Control Board Division of Water Quality c/o DMR Processing Center 1001 I Street, 15 th Floor Sacramento, CA 95814

2. All discharge monitoring results must be reported on the official USEPA pre-printed DMR forms (EPA Form 3320-1). Forms that are self-generated will not be accepted unless they follow the exact same format of EPA Form 3320-1.

D. Other Reports

1. The Discharger shall report the results of any acute toxicity testing and TRE/TIE required by Special Provisions – VI.C.2 of this Order. The Discharger shall submit reports in compliance with SMR reporting requirements described in section X above.
2. **Within 90 days** of the effective date of this permit, the Discharger is required to submit the following to the Regional Water Board:
 - f. Initial Investigation TRE workplan
 - g. Updated SWPPP
3. By **March 1** of each year, the Discharger shall submit an annual report to the Regional Water Board. The report shall contain the following:

- a. Both tabular and graphical summaries of the monitoring data obtained during the previous year,
 - b. A discussion on the compliance record and the corrective actions taken or planned to bring the discharge into full compliance with the waste discharge requirements,
 - c. A report discussing the following: 1) operation/maintenance problems; 2) changes to the facility operations and activities; 3) potential discharge of the pollutants associated with the changes and how these changes are addressed in the BMPP; 3) calibration of flow meters or other equipment/device used to demonstrate compliance with effluent limitations of this Order.
 - d. A report summarizing the quantities of all chemicals, listed by both trade and chemical names, which are used at the facility and which are discharged or have the potential to be discharged.
 - e. A report on the status of the implementation and the effectiveness of the SWPPP, BMPP, and Spill Contingency Plan.
4. As discussed in Section IC.C of the MRP, Attachment E, the Discharger shall submit to the Regional Water Board, together with the first monitoring report required by this permit, a list of all chemicals and proprietary additive which would affect this waste discharge, including quantities of each. Any subsequent changes in types and/or quantities shall be reported promptly.
 5. This Regional Water Board requires the Discharger to file with the Regional Water Board, **within 90 days** after the effective date of this Order, a technical report on his preventive (failsafe) and contingency (cleanup) plans for controlling accidental discharges, and for minimizing the effect of such events. The technical report should:
 - a. Identify the possible sources of accidental loss, untreated waste bypass, and contaminated drainage. Loading and storage areas, power outage, waste treatment unit outage, and failure of process equipment, tanks and pipes should be considered.
 - b. Evaluate the effectiveness of present facilities and procedures and state when they become operational.
 - c. Describe facilities and procedures needed for effective preventive and contingency plans.
 - d. Predict the effectiveness of the proposed facilities and procedures and provide an implementation schedule contingent interim and final dates when they will be constructed, implemented, or operational.

This Regional Water Board, after review of the technical report, may establish conditions which it deems necessary to control accidental discharges and to minimize the effects of such events. Such conditions may be incorporated as part of this Order, upon notice to the Discharger

ATTACHMENT F – FACT SHEET

Table of Contents

I.	Permit Information	F-4
II.	Facility Description	F-5
	A. Description of Discharge	F-10
	B. Discharge Points and Receiving Waters	F-12
	C. Summary of Existing Requirements and Self-Monitoring Report (SMR) Data	F-13
	D. Compliance Summary	F-16
	E. Planned Changes	F-17
III.	Applicable Plans, Policies, and Regulations	F-17
	A. Legal Authorities	F-17
	B. California Environmental Quality Act (CEQA)	F-17
	C. State and Federal Regulations, Policies, and Plans	F-17
	D. Watershed Management Approach	F-21
	E. Impaired Water Bodies on CWA 303(d) List	F-22
	F. Total Maximum Daily Loads (TMDL)	F-22
	G. Title 22 of the California Code of Regulations	F-26
	H. Perchlorate	F-26
	I. Other Plans, Policies and Regulations	F-27
IV.	Rationale For Effluent Limitations and Discharge Specifications	F-27
	A. Discharge Prohibitions	F-27
	B. Technology-Based Effluent Limitations	F-28
	1. Scope and Authority	F-28
	2. Applicable Technology-Based Effluent Limitations	F-29
	C. Water Quality-Based Effluent Limitations (WQBELs)	F-30
	1. Scope and Authority	F-30
	2. Applicable Beneficial Uses and Water Quality Criteria and Objectives	F-30
	3. Determining the Need for WQBELs	F-38
	4. WQBEL Calculations	F-41
	5. WQBELs based on Basin Plan Objectives	F-45
	6. Whole Effluent Toxicity (WET)	F-46
	7. Final WQBELs	F-46
	D. Final Effluent Limitations	F-48
	1. Satisfaction of Anti-Backsliding Requirements	F-48
	2. Satisfaction of Antidegradation Policy	F-49
	3. Stringency of Requirements for Individual Pollutants	F-49
	4. Mass-based Effluent Limitations	F-50
	5. Receiving Water Limitations	F-58
	6. Final Receiving Water Sediment Effluent Limitations for Arroyo Simi	F-58
	7. Interim Ambient WLAs for Pollutants in Sediment for Storm Water Discharges to Arroyo Simi	F-59
	E. Land Discharge Specifications	F-59
	F. Reclamation Specifications	F-59
V.	Rationale for Receiving Water Limitations	F-59

A.	Surface Water	F-59
B.	Groundwater	F-60
VI.	Rationale for Monitoring and Reporting Requirements	F-60
A.	Influent Monitoring	F-60
B.	Effluent Monitoring	F-60
C.	Storm Water Monitoring	F-60
D.	Whole Effluent Toxicity Testing Requirements	F-60
E.	Receiving Water Monitoring	F-61
1.	Surface Water	F-61
2.	Groundwater	F-61
F.	Sediment Monitoring and Reporting	F-61
G.	Bioassessment Monitoring	F-61
VII.	Rationale for Provisions	F-62
A.	Standard Provisions	F-62
B.	Special Provisions	F-62
1.	Reopener Provisions	F-62
2.	Special Studies and Additional Monitoring Requirements	F-62
3.	Best Management Practices and Pollution Prevention	F-62
4.	Construction, Operation, and Maintenance Specifications	F-63
5.	Special Provisions for Municipal Facilities (POTWs Only)	F-63
6.	Other Special Provisions	F-63
VIII.	Public Participation	F-63
A.	Notification of Interested Parties	F-63
B.	Written Comments	F-63
C.	Public Hearing	F-63
D.	Nature of Hearing	F-64
E.	Parties to the Hearing	F-64
F.	Public Comments and Submittal of Evidence	F-64
G.	Hearing Procedure	F-64
H.	Waste Discharge Requirements Petitions	F-65
I.	Information and Copying	F-65
J.	Register of Interested Persons	F-65
K.	Additional Information	F-65

List of Tables

Table F-1.	Facility Information	F-4
Table F-2.	Historic Effluent Limitations and Monitoring Data Outfalls 001, 002, 011, 018, and 019	F-13
Table F-2a.	Historic Effluent Limitations and Monitoring Data Outfalls 003 - 010	F-14
Table F-3.	Basin Plan Beneficial Uses	F-18
Table F-3a.	Basin Plan Beneficial Uses	F-19
Table F-4.	Summary of Technology-based Effluent Limitations/Benchmarks* Outfalls 001-002, 011-014, 018, 019	F-29
Table F-4a.	Summary of Technology-based Effluent Limitations Outfalls 003 - 010	F-30
Table F-5a.	Applicable Water Quality Criteria	F-31
Table F-5b.	Toxicity Equivalency Factors and Bioaccumulation Equivalency Factors	F-35

Table F-5c. Applicable Basin Plan Numeric Water Quality Objectives..... F-36
Table F-6a. Summary of Reasonable Potential Analysis Outfalls 011, 018, 019..... F-39
Table F-6b. Summary of Reasonable Potential Analysis Outfalls 003 - 010 F-40
Table F-7. Summary of Water Quality-based Effluent Limitations for Outfalls 001, 002, 011, 018, 019 F-46
Table F-7a. Summary of Water Quality-based Effluent Limitations for Outfalls 003-010.... F-48
Table F-8. Summary of Final Effluent Limitations for Outfalls 011, 018, and 019..... F-50
Table F-8a. Summary of Final Effluent Limitations for Outfalls 003-010 F-53
Table F-8b - Summary of Benchmarks* – Outfalls 012-014 F-56
Table F-9. Summary of Receiving Water Limitations for Arroyo Simi..... F-58
Table F-10. Summary of Final Receiving Water Sediment Limitations for Arroyo Simi..... F-58
Table F-11. Summary of Interim Ambient Receiving Water Sediment Limitations for Arroyo Simi F-59

ATTACHMENT F – FACT SHEET

As described in section II of this Order, this Fact Sheet includes the legal requirements and technical rationale that serve as the basis for the requirements of this Order. This Order has been prepared under a standardized format to accommodate a broad range of discharge requirements for dischargers in California. Only those sections or subsections of this Order that are specifically identified as “not applicable” have been determined not to apply to this Discharger. Sections or subsections of this Order not specifically identified as “not applicable” are fully applicable to this Discharger.

I. PERMIT INFORMATION

The following table summarizes administrative information related to the Facility.

Table F-1. Facility Information

WDID	
Discharger	The Boeing Company
Name of Facility	Santa Susana Field Laboratory
Facility Address	6800 Woolsey Canyon Road
	Canoga Park, CA 91304-1148
	Ventura County
Facility Contact, Title and Phone	Thomas Gallacher, Director SSFL – Environmental Health and Safety (818) 466-8161
Authorized Person to Sign and Submit Reports	Thomas Gallacher, Director (818) 466-8161
Mailing Address	5800 Woolsey Canyon Road Canoga Park, CA 91304-1148
Billing Address	SAME
Type of Facility	Research and development
Major or Minor Facility	Major
Threat to Water Quality	2
Complexity	B
Pretreatment Program	Not Applicable
Reclamation Requirements	Not Applicable
Facility Permitted Flow	168 million gallons per day (mgd)
Facility Design Flow	Not applicable
Watershed	Los Angeles River Watershed, Calleguas Creek Watershed
Receiving Water	Bell Creek, Arroyo Simi
Receiving Water Type	Inland Surface Water

- A. The Boeing Company (hereinafter Boeing or Discharger) discharges waste from its Santa Susana Field Laboratory (hereinafter SSFL or Facility), under waste discharge requirements which serve as a National Pollutant Discharge Elimination System (NPDES) permit, contained in Order R4-2009-0058 adopted by this Regional Water Board on May 8, 2009 (NPDES No. CA0001309).

For the purposes of this Order, references to the “discharger” or “permittee” in applicable federal and state laws, regulations, plans, or policy are held to be equivalent to references to the Discharger herein.

- B. The Facility discharges storm water runoff and treated groundwater to tributaries of the Los Angeles River and Calleguas Creek, waters of the United States. The current permit Order No. R4-2009-0058, expires on April 10, 2014.
- C. This update is the result of the annual review of new data submitted to the Regional Water Board as per the Monitoring and Reporting Program.

II. FACILITY DESCRIPTION

SSFL occupies approximately 2,850 acres and is located at the top of Woolsey Canyon Road in the Simi Hills, Ventura County, California. The Facility is jointly owned by Boeing and the United States of America. The National Aeronautics and Space Administration (NASA) administers the portion of the property owned by the federal government. The site is divided into four administrative areas (Areas I, II, III, and IV) and undeveloped land areas to both the north and south. The NASA property includes a portion of Area I and all of Area II. The United States Department of Energy (DOE) also owns several buildings that were constructed on land owned by Boeing in the northwest portion in Area IV.

The developed portion of the site comprises approximately 1,500 acres. Boeing and its predecessors' operations at SSFL since 1950 included research, development, assembly, disassembly, and testing of small scale nuclear reactors, rocket engines, and chemical lasers. During the 1950s to the mid-1970s, volatile organic compounds were utilized for the cleaning of hardware and rocket engine thrust chambers, and for the cleaning of other equipment. These solvents migrated into the subsurface, contaminating groundwater primarily with trichloroethylene (TCE) and 1,2-dichloroethylene (1,2-DCE). NASA operations included rocket engine assembly and testing, and propellant and fuel storage and loading. DOE conducted past operations in research and development of energy related programs, and seismic testing experiments. The activities included developing and operating reactors, and fabricating and disassembling nuclear fuel. The DOE began to phase out the program in the 1960s. The last reactor was shut down in 1980, and nuclear research was terminated in 1989. The research and the associated activities resulted in residual contamination.

Following is a more detailed description of some activities that may have contributed to onsite contamination.

Rocket Engine and Component Testing: Rocket engine testing began at the SSFL site in 1950s. An engine test consisted of a cycle of one to three engine runs lasting one to

three minutes each. A test cycle may take one to two weeks to complete. Each engine run resulted in the use of 50,000 to 200,000 gallons of deluge/cooling water that contacted fuels such as liquid oxygen (LOX) or kerosene and associated combustion products. The frequency of testing historically varied depending on production requirements. In July 2004, the frequency of testing was one test cycle every one or two months. In late 2006, the rocket engine and component testing operations at the facility were terminated. These tests generated fuel related contaminants and heavy metals. Three of the test stands and the associated spillways are present onsite. Storm water runoff from these areas is monitored or collected and transported to the treatment system at Silvernale for treatment prior to monitoring and discharge.

Groundwater Remediation: During the early 1950s to the mid-1970s, volatile organic compounds were used for the cleaning of hardware and rocket engine thrust chambers and for the cleaning of other equipment. These solvents migrated into the subsurface contaminating groundwater primarily with trichloroethylene (TCE) and 1,2-dichloroethylene (1,2-DCE).

As a result, in July 2004 there was an extensive groundwater remediation/investigation program in progress at SSFL, which included pumping, treating, and storing groundwater at the facility for reuse. Groundwater remediation activities at the site were terminated in 2005 as a result of fires that destroyed much of the system. The groundwater was historically treated to remove volatile organic compounds. Perchlorate was also detected in some wells and treatment systems implemented for those wells included operations to remove perchlorate. Boeing is in the process of designing, installing equipment and constructing a modified central groundwater treatment system. All extracted groundwater will be piped over to a treatment unit located in Area 1. The effluent from the treatment system will be discharged at Outfall 019.

Water Reclamation System and Discharges: Historically, SSFL utilized a system of natural, unlined, and man-made ponds and channels to collect water from onsite operations. Water supplied to the retention system came from any one or a combination of the storm water runoff, treated groundwater, treated sanitary sewage, rocket engine test cooling water or drinking water purchased from an established purveyor (Calleguas Municipal Water District).

The water reclamation system consisted of five ponds: R-1, Perimeter, Silvernale, R2-B and R2-A. The ponds are unlined basins with capacities that ranged from 200,000 gallons to 6.0 million gallons.

The SSFL is underlain by alluvium, weathered bedrock and unweathered bedrock. The alluvium occurs in narrow drainages and alluvial valleys and is underlain by the Chatsworth Formation. The Chatsworth Formation consists of fractured sandstone with interbeds of siltstone and claystone, which can transmit water as well as contaminants. The ponds have also been identified as solid waste management units (SWMU) under the Resource Conservation and Recovery Act (RCRA) cleanup and assessment that is progressing with oversight by the California Department of Toxic Substances Control (DTSC).

Storm Water Discharges: In 1989, the Environmental Protection Agency (EPA) conducted an investigation and submitted a report on SSFL environmental issues. The report recommended that the Regional Water Board use the Clean Water Act to ensure run-off from the northwest side of Area IV was not contaminated. In response to the request Boeing developed a surface water monitoring program for the northwest slope area that was subsequently approved by EPA and implemented. The monitoring locations were established to collect runoff from past radiological facilities. The data collected resulted in establishing the monitoring locations as compliance points with effluent limits for radiologicals and for a number of other priority pollutants.

More recently, additional storm water monitoring locations have been established to capture runoff from areas associated with historical activities that have resulted in contamination. There are currently fifteen locations that discharge storm water only.

Current activities at the site include:

Site investigation and cleanup. An investigation is ongoing regarding the nature and extent of contamination that has resulted from historical operations. Some removals of contaminated soils have occurred and more are anticipated. These activities are being conducted under the oversight of and in accordance with procedures established by the California Environmental Protection Agency (Cal-EPA) Department of Toxic Substances Control (DTSC). Information regarding the investigation and cleanup activities can be found at the following website established by DTSC: http://www.dtsc.ca.gov/SiteCleanup/Projects/Santa_Susana.cfm. Investigation and cleanup activities are not expected to result in discharges of water. Some water may be applied to excavation areas for support activities and dust control. This water will be contained and removed or allowed to evaporate and infiltrate and not flow to a pond or outfall. Best Management Practices (BMPs) to prevent the movement of sediments or contaminants from investigation areas to the extent practicable are implemented and maintained during invasive investigation work at these areas. When invasive investigation work is not taking place, site vegetation is maintained and where vegetation is insufficient, BMPs are implemented and maintained to minimize movement of sediments or contaminants from these areas.

Groundwater Sampling, Extraction and Treatment. As part of the ongoing investigation into the nature and extent of groundwater contamination and the testing of different groundwater cleanup and management strategies, groundwater is routinely sampled from numerous wells across the facility. In specific areas, groundwater is extracted over longer periods of time to control groundwater elevations and to test conceptual models regarding groundwater constituent fate and transport and appropriate cleanup and management strategies. Additionally, potable water is occasionally used for rinsing and maintenance of structural storm water treatment control Best Management Practices at the outfalls. The groundwater and potable water used onsite are currently hauled offsite for disposal but will be treated onsite and discharged at a single separate outfall, Outfall 019, once a new central treatment system comes online. Treatment of these flows will consist of air stripping to remove volatile organic compounds, green sand to remove iron, manganese

and other trace metals, and granular activated carbon to complete final polishing of the water.

Demolition and Decommissioning. Demolition and decommissioning of building and facilities are ongoing. These operations are not expected to generate waste water discharges. However, these operations may result in the exposure of contaminants in surface soils that were previously covered. These operations may also result in exposure to potential releases as impacted buildings and/or equipment is dismantled. BMPs will be implemented during these operations to minimize sediment or potential contaminant migration.

Laser Research. Some small scale laser research occurs onsite inside enclosed laboratories. There are no associated discharges to surface waters.

Local Fire Department Training. Fire departments in the area routinely utilize a small portion of the site for staff training exercises. These exercises result in small releases of water and retardant. The retardant materials are collected and removed. The released water is contained and either allowed to evaporate or infiltrate. The water is not allowed to flow into a pond or to flow offsite via an outfall.

Routine Maintenance Activities. The repair and maintenance activities includes safety shower inspections, air conditioning system maintenance, fire hydrant inspection and testing, quarterly testing of the sprinkler risers at the buildings, testing of the perimeter sprinklers systems, testing of irrigation systems, and fire station maintenance. These operations include the periodic release of small amounts of potable water to the ground. The water is allowed to evaporate and infiltrate.

Current Discharges

Storm water runoff is currently the sole permitted discharge from the facility. The storm water while traversing the site has historically contained elevated concentrations of a number of contaminants present onsite as a result of historical operations.

Discharges from the site are regulated under an NPDES permit No. CA0001309. When originally issued, the permit authorized discharges of storm water, storm water mixed with wastewater, and wastewater. Operations at the SSFL have changed over the years, and wastewater discharges have been eliminated from 15 of the 16 outfalls at the SSFL. The only wastewater discharge permitted in this Order is treated groundwater which will be discharged from Outfall 019.

Two south facing watersheds have large ponds within them. The watershed leading to Outfalls 011 and 001 includes R-1 Pond and Perimeter Pond. The watershed leading to Outfalls 018 and 002 includes Silvernale Pond and R-2 Pond. After excessive rainfall, the ponds overflow and discharge through Outfalls 011 and 018, respectively. Some of the pond overflows, depending on the size of the rain event and the onsite storage capacity available, cause flow at Outfalls 001 and 002. Other overflows do not. Whether the overflows cause flow at Outfalls 001 and 002 depends on the quantity of rainfall and soil

moisture conditions before the rain begins. In addition, during some rainfall events, Outfalls 001 or 002 will flow even when there are not overflows at Outfalls 011 or 018 because of the substantial area of undeveloped property between Outfalls 011 and 001 and between Outfalls 018 and 002 from which rainwater runs off.

As a result of soil, sediment, and ground water contamination on site, the Facility is currently undergoing investigation and corrective action with oversight from California Department of Toxic Substances Control (DTSC) for the Resource Conservation and Recovery Act (RCRA) activities. A description of the framework of site activities follows.

The 1995 Final SB 1082 Framework which was issued on December 14, 1995, documents the framework for implementing Health and Safety Code Section 25204.6(b) dealing with jurisdictional overlap between DTSC and the Regional Water Quality Control Boards (RWQCBs). SB 1082 requires that "sole jurisdiction over the supervision of that action [meaning oversight of those corrective action activities] is vested in either the department or the State Water Resources Control Board and the California Regional Water Quality Control Boards." Since many of the identified wastewater sources are currently involved in the RCRA corrective action or the Post Closure Permits with DTSC as the oversight agency, consistent with RCRA, DTSC will ensure that the discharges from these operations through the RCRA permitting process meet the substantive Clean Water Act requirement. Regional Water Board staff will provide appropriate comments during the revision of RCRA permits to ensure the Clean Water Act, Porter-Cologne Act, and the Basin Plan requirement are met. However, at all times, the final downstream Outfalls 001 and 002 or Outfalls 011 and 018 will be regulated by the accompanying NPDES permit and will implement relevant water quality standards.

On December 3, 2008, the Regional Water Board issued a Section 13304 Interim/Source Removal Action (ISRA) of Soil in the Areas of Outfalls 008 and 009 Drainage Areas, to the Boeing Company Santa Susana Field Laboratory. Boeing was directed to cleanup the wastes that are discharging to waters of the State, minimize impacts to the streambed and to adjacent habitat during the cleanup, protect the water quality during and after cleanup, and restore the streambed and surrounding habitat following the cleanup.

Compliance with the Section 13304 Order is ongoing. The Discharger submitted a proposed work plan, which would result in compliance with the 13304 Order. During the 2009-2010 dry weather season, ISRA activities included the excavation of 5,000 cubic yards of soil from the Watershed of Outfall 008. The primary constituents of concern were lead, copper, and dioxins (TCDD-TEQs). Activities in the Outfall 009 Watershed to date have resulted in the excavation of 153 cubic yards of soil. The constituents of concern for the Outfall 009 Watershed excavation were dioxins and lead.

The Regional Water Board has determined that the work plan sets forth an appropriate schedule, for the completion of the clean-up and the evaluation of the impact of the clean-up on the NPDES permit compliance. This effort can feasibly be completed by June 3, 2012.

A. Description of Discharge

The discharge from the SSFL regulated by this permit is composed primarily of storm water runoff that traverses the site. The storm water picks up contaminants present on site as a result of past activities.

Storm water

Storm water is currently the primary discharge from the site and represents approximately 99 percent of water discharged from the site. Storm water discharges occur periodically when there is sufficient rain to cause flow within the outfall drainages. A Storm water Management Model 5.0.013 (SWMM) (USEPA, 2008) was employed to estimate storm water discharges at outfalls 001-011 and 018 at the facility. The estimated flows for Outfalls 001, 002, 011, and 018 were compared to flow meter readings at Outfalls 001, 002, 011, and 018 to verify that the estimates were within range of the measured flows.

Cumulative volume hydrographs were developed for each outfall for the 100-year 24-hour, 10-year 24-hour storm, and 1-year 24-hour storms to estimate the daily flow expected from such events. Table 1 lists the estimated daily storm water discharges.

Table 1: Estimated Storm water Discharges by Outfall*

Outfall	Area (acres)	100-yr 24-hr V (MGD)	10-yr 24-hr V (MGD)	1-yr 24-hr V (MGD)
001	306	72.9	33.7	6.97
002	603	109	50.6	10.7
003	13.9	1.7	0.79	0.17
004	6.5	0.96	0.55	0.19
005	0.3	0.0025	0.0015	0.0007
006	12.9	1.67	0.81	0.2
007	2.8	0.4	0.2	0.05
008 ¹	62	10	4.8	0.36
009 ¹	536	78	35	3.0
010	5.3	0.69	0.38	0.12
011	290.7	37.2	17.3	3.73
012	0.077	0.019	0.012	0.0052
013	0.32	0.078	0.049	0.022
014	0.51	0.13	0.08	0.035
018	539.2	60.3	27.9	5.88
Sums		360	167	35

MGD million gallons per day for 24 hour period
 V is the 24 hour discharge volume – not a peak flow rate.
 * Assumptions used in the modeling approach include:

- The 1, 10, and 100-year rain depths used were 2.5, 5.7 and 9.0 inches, respectively; these are based on an analysis of local rain gauge data rather than isohyets reported in the Ventura County hydrology manual.
 - Antecedent moisture conditions were assumed to be equal to field capacity.
 - The LA county hydrology manual unit hyetograph was used.
 - Imperviousness values accounted for the disconnected natural imperviousness (i.e., exposed bedrock) that is found in each watershed.
- ¹ Runoff volume estimates for Outfalls 008 and 009 were taken from the ENTS hydrology report (Geosyntec, 2008).

In an effort to control the transport of contaminants off site, the Discharger has recently implemented a treatment system adjacent to the Silvernale Pond upstream from Outfall 018. The Outfall 018 Temporary Storm Water Treatment System (TSTS) consists of water treatment and solids removal systems. Water from R-2 Pond is pumped uphill to Silvernale Pond for treatment at the Outfall 018 TSTS. Potassium permanganate (KMnO₄), aluminum sulfate (alum) and polymer are injected into the water at different stages to enhance treatment. The KMnO₄ oxidizes iron and manganese so that it will precipitate out of solution. The alum and polymer stimulate coagulation and flocculation of fine sediments with co-precipitation of other metals and constituents. The water treatment system is comprised of screen filters, equalization tanks, contact tanks, two banks of sand filters, bag filters, and granular activated carbon (GAC) filters. Effluent from the treatment system is discharged at Outfall 018 at approximately 1,000 gallons per minute. The addition of alum and polymer coagulation followed by settling and filtration produces solids that are backwashed to a solids holding tank and later removed in a system comprised of a weir and lamella plate tank, solids holding tanks, and a centrifuge. Dewatered solids from this system are collected in roll-off bins and transported offsite for disposal. The supernatant is routed back to the front end of the water treatment system. Construction of the Outfall 018 TSTS began in November 2009 and was completed in the First Quarter of 2010. The system was operational during all discharges that occurred at Outfall 018 during the First Quarter 2010 with chemical adjustment occurring through March 2010. The results of the 2009-2010 storm season are being used to better define the treatment system that will be put in place at Outfalls 011 and 018 for the 2010-2011 storm season.

Future Treated Groundwater Discharge

Boeing is currently designing and will construct a modified central groundwater treatment system. The system will be located in Area I downstream of the R-1 Pond and upstream of the Perimeter Pond. Extracted groundwater will be pumped to this new central groundwater treatment system that will discharge at a new outfall location (Outfall 019), which is located downstream of Outfall 001. Well purge water and potable rinse water from BMP rinsing, and groundwater generated during well installations or pumping tests will be transported to the central groundwater treatment system. The primary compounds of potential concern (COPCs) are volatile organic compounds (VOCs), semi-volatile organic compounds (SVOCs) (primarily 1,4-dioxane), n-nitrosodimethylamine (NDMA), perchlorate, and some metals. The maximum flow rate of extracted groundwater once the new groundwater treatment system is fully

operational is 0.3 MGD. Monitoring of the effluent will occur after all treatment operations prior to discharge to the receiving water.

The location of the discharge from the groundwater treatment system to the receiving water downstream of Outfall 001 segregates the discharge of the treated groundwater from the discharge of storm water. The treated groundwater discharge, once it is initiated will occur continuously. Thus the discharge will be required to meet both monthly average and daily maximum effluent limitations. This is consistent with other treated wastewater permits.

Putting the discharge into the receiving water downstream of areas that may be disturbed during remediation and downstream of areas that may have contaminated soil or sediments ensures that the discharge does not provide a method of transport for contaminants that may be present between Outfall 001 and the location of the groundwater treatment system (upstream of Outfall 011).

The treatment process will involve conveyance of the water to a storage tank located at the treatment facility. From the storage tank, water will pass through filtration or settling systems for the removal of particulates. Depending on groundwater quality and COPCs, groundwater will be treated by one or more of the following processes: filtration, ion exchange, advanced coagulation/precipitation, green sand filtration, air stripping, liquid phase granular activated carbon (GAC), and ultraviolet (UV) oxidation. If air stripping is utilized, the effluent vapor generated by the process will pass through vapor phase GAC prior to discharge to the atmosphere. Liquid and vapor phase GAC will be hauled offsite for disposal or regeneration at an authorized off-site, licensed facility. Other treatment residuals will be properly characterized, manifested, and hauled offsite for proper disposal or regeneration at an authorized licensed facility.

B. Discharge Points and Receiving Waters

SSFL has the potential (based on a 24-hour duration, 10 year return storm event) to discharge approximately 167 million gallons per day (MGD) of storm water runoff that has the potential to contain pollutants from the facilities. Approximately 70% of the discharge exits the property via two southerly discharge points (Discharge Outfalls 001 and 002) to Bell Creek, a tributary to the Los Angeles River, a water of the United States, with its confluence located near the intersection of Bassett Street and Owensmouth Avenue in Canoga Park. Upstream outfalls that contribute to the discharge at Outfalls 001 and 002 include Outfalls 011, 012, 013, 014, and 018. Outfall 019 discharges treated groundwater downstream of Outfall 001. Outfalls 015, 016, 017 are the locations of the three package type sewage treatment plants which are no longer used. Wastewater generated onsite is collected in the collection basins of the plants and periodically trucked off site for disposal at one of Los Angeles County Sanitation District's Public Owned Treatment Work (POTW) facilities.

The storm water from the northern boundaries of the site is discharged via Outfalls 003 through 007, 009 and 010 toward the Arroyo Simi. The storm water runoff from Happy Valley (Outfall 008) flows via Dayton Canyon Creek to Chatsworth Creek. Chatsworth

Creek flows south to Bell Creek southwest of the intersection of Shoup Avenue and Sherman Way. Bell Creek subsequently flows southeast to the Los Angeles River.

C. Summary of Existing Requirements and Self-Monitoring Report (SMR) Data

Effluent limitations contained in the existing Order for discharges from Discharge Point 001 (Monitoring Location EFF-001) and monitoring data representing the quality of effluent discharged during the previous permit term are as follows:

Table F-2. Historic Effluent Limitations and Monitoring Data Outfalls 001, 002, 011, 018, and 019

Parameter	Units	Effluent Limitation			Monitoring Data (1/13/2004 – 12/2009)	
		Instantaneous Maximum / Minimum	Average Monthly	Average Weekly		Maximum Daily
Flow	gpd	--	--	--		
Biochemical Oxygen Demand (BOD)(5-day @20 Deg. C)	mg/L	--	20	--	30	33
Oil and Grease	mg/L	--	10	--	15	17
pH	s.u.	6.5/8.5	--	--	--	--
Total Suspended Solids (TSS)	mg/L	--	50	45	--	33000
Barium	mg/L	--	--	--	1	2.3
Fluoride	mg/L	--	--	--	1.6	--
Iron	mg/L	--	--	--	0.3	97
Detergents (as MBAS)	mg/L	--	--	--	0.5	10
Nitrite-N	mg/L	--	--	--	1.0	0.2
Ammonia-N	mg/L	--	1.96	--	10.1	13
Nitrate-N	mg/L	--	--	--	8.0	38
Total Manganese	µg/L	--	--	--	50	11000
Total Cyanide	µg/L	--	4.3	--	8.5	18
Total Antimony	µg/L	--	--	--	6.0	1.3
Total Arsenic	µg/L	--	--	--	10	35
Total Beryllium	µg/L	--	--	--	4.0	11
Total Cadmium	µg/L	--	2.0	--	4.0/3.1	6.9
Total Chromium VI	µg/L	--	8.1	--	16.3	0.65
Total Copper	µg/L	--	7.1	--	14	100
Total Lead	µg/L	--	2.6	--	5.2	3.10
Total Mercury	µg/L	--	0.05	--	0.10	0.32
Total Nickel	µg/L	--	35	--	96	100
Total Selenium	µg/L	--	4.1	--	8.2	2
Total Silver	µg/L	--	2.0	--	4.1	1
Total Thallium	µg/L	--	--	--	2.0	1.9
Total Zinc	µg/L	--	54	--	119	790
1,1-Dichloroethylene	µg/L	--	3.2	--	6.0	ND ¹
Trichloroethylene	µg/L	--	--	--	5.0	ND ¹

Parameter	Units	Effluent Limitation			Monitoring Data (1/13/2004 – 12/2009)	
		Instantaneous Maximum / Minimum	Average Monthly	Average Weekly		Maximum Daily
Perchlorate	µg/L	--	--	--	6.0	5.8
TCDD	µg/L	--	1.4E-08	--	2.8E-08	4.3x10 ⁻⁵
2,4,6-Trichlorophenol	µg/L	--	6.5	--	13	4.1
2,4-Dinitrotoluene	µg/L	--	9.1	--	18	0.23
Alpha BHC	µg/L	--	0.01	--	0.03	0.015
Bis(2-ethylhexyl)phthalate	µg/L	--	--	--	4.0	ND
N-nitrosodimethylamine	µg/L	--	8.1	--	16	3.7
Pentachlorophenol	µg/L	--	8.2	--	16	4
Radioactivity Gross Alpha	pCi/L	--	--	--	15	17.3
Gross Beta	pCi/L	--	--	--	50	20
Combined Radium-226 & Radium-228	pCi/L	--	--	--	5.0	17
Tritium	pCi/L	--	--	--	20.000	230
Strontium-90	pCi/L	--	--	--	8.0	2.8
Acute Toxicity	% survival	--	--	--	2	--
Chloride		--	--	--	150	84
Chlorine, Total Residual	mg/L	--	--	--	0.1	0.2
Dissolved Oxygen	mg/L	--	--	--	--	--
Nitrate + Nitrite (as N)	mg/L	--	--	--	8	10
Settleable solids	ml/L	--	0.1	--	0.3	10
Sulfate	mg/L	--	--	--	300	400
Sulfides	mg/L	--	--	--	1.0	
Temperature	°F	--	--	--	100	--
Total Dissolved Solids (TDS)	mg/L	--	--	--	950	1000
Turbidity	NTU	--	50	--	75	--

¹ ND = Not detected; results reported as below detection limits.

² Average survival in undiluted effluent for any three (3) consecutive 96-hour static or continuous flow bioassay tests shall be at least 90% and no single test producing less than 70% survival.

Table F-2a. Historic Effluent Limitations and Monitoring Data Outfalls 003 - 010

Parameter	Units	Instantaneous Maximum / Minimum	Effluent Limitation	Monitoring Data (1/13/2004 – 12/2009)
			Maximum Daily	
Flow	gpd	--	--	
Oil and Grease	mg/L	--	15	16
pH	s.u.	6.5/8.5	--	9.7
Total Suspended Solids (TSS)	mg/L	--	--	4,000
Fluoride	mg/L	--	1.6	0.46

Parameter	Units	Instantaneous Maximum / Minimum	Effluent Limitation	Monitoring Data (1/13/2004 – 12/2009)
			Maximum Daily	
Nitrite-N	mg/L	--	1.0	ND
Ammonia-N	mg/L	--	10.1	1.1
Nitrate-N	mg/L	--	8.0	7.7
Total Cyanide	µg/L	--	8.5	2.9
Total Antimony	µg/L	--	6.0	35
Total Arsenic	µg/L	--	10	27
Total Beryllium	µg/L	--	4.0	ND
Total Cadmium	µg/L	--	4.0/3.1	9.2
Total Chromium	µg/L	--	16.3	14
Total Copper	µg/L	--	14	39
Total Lead	µg/L	--	5.2	260
Total Mercury	µg/L	--	0.10	0.89
Total Nickel	µg/L	--	96	15
Total Selenium	µg/L	--	8.2	4.7
Total Silver	µg/L	--	4.1	4.1
Total Thallium	µg/L	--	2.0	0.41
Total Zinc	µg/L	--	119	91
1,1-Dichloroethylene	µg/L	--	6.0	ND
Trichloroethylene	µg/L	--	5.0	0.66
Perchlorate	µg/L	--	6.0	2.5
TCDD	µg/L	--	2.8E-08	9.1E-04
2,4,6-Trichloroophenol	µg/L	--	13	ND
2,4-Dinitrotoluene	µg/L	--	18	ND
Alpha BHC	µg/L	--	0.03	ND
Bis(2-ethylhexyl)phthalate	µg/L	--	4.0	ND
N-nitrosodimethylamine	µg/L	--	16	ND
Pentachlorophenol	µg/L	--	16	ND
Radioactivity Gross Alpha	pCi/L	--	15	16.3
Gross Beta	pCi/L	--	50	62
Combined Radium-226 & Radium-228	pCi/L	--	5.0	1.9
Tritium	pCi/L	--	20,000	300
Strontium-90	pCi/L	--	8.0	11.4
Acute Toxicity	% survival	--	3	--
Chloride		--	150	210
Nitrate + Nitrite (as N)	mg/L	--	8	51
Sulfate	mg/L	--	300	240
Temperature	°F	--	86	70.8
Total Dissolved Solids (TDS)	mg/L	--	950	980

D. Compliance Summary

Monitoring data collected from Fourth Quarter 2006 through First Quarter 2009 yielded the following violations of the NPDES permit.

Outfall	Date	Monitoring Period	Violation Type	Parameter	Reported Value	Permit Limit	Units
001	01/31/06	1st Quarter 2006	Monthly	CN (Cyanide)	7.4	4.3	ug/L
005	02/28/06	1st Quarter 2006	Daily	(NO2+NO3) as N	40	10	mg/L
002	02/28/06	1st Quarter 2006	Daily	CN (Cyanide)	18	8.5	ug/L
002	02/28/06	1st Quarter 2006	Monthly	CN (Cyanide)	18	4.3	ug/L
001	02/28/06	1st Quarter 2006	Monthly	CN (Cyanide)	7.3	4.3	ug/L
005	03/29/06	1st Quarter 2006	Daily	(NO2+NO3) as N	43	10	mg/L
005	04/05/06	2nd Quarter 2006	Daily	(NO2+NO3) as N	23	10	mg/L
005	04/15/06	2nd Quarter 2006	Daily	(NO2+NO3) as N	22	10	mg/L
018	05/31/06	2nd Quarter 2006	Monthly	TSS	20	15	mg/L
010	12/10/06	4th Quarter 2006	Daily	TCDD	3.31E-07	2.8E-08	ug/L
003	01/28/07	1st Quarter 2007	Instantaneous	pH	9.6	6.5-8.5	pH units
003	01/28/07	1st Quarter 2007	Daily	Gross Beta	56.3 ± 1.9	50	pCi/L
006	01/28/07	1st Quarter 2007	Daily	Chloride	210	150	mg/L
003	02/19/07	1st Quarter 2007	Instantaneous	pH	9	6.5-8.5	pH units
006	02/19/07	1st Quarter 2007	Daily	Gross Beta	63.8 ± 2.8	50	pCi/L
009	02/19/07	1st Quarter 2007	Daily	TCDD	7.64E-07	2.8E-08	ug/L
004	09/22/07	3rd Quarter 2007	Daily	Hg	0.23	0.13	ug/L
004	09/22/07	3rd Quarter 2007	Daily	TCDD	2.54E-06	2.8E-08	ug/L
009	09/22/07	3rd Quarter 2007	Daily	TCDD	3.13E-06	2.8E-08	ug/L
006	12/07/07	4th Quarter 2007	Daily	Chloride	170	150	mg/L
004	12/19/07	4th Quarter 2007	Daily	TCDD	3.97E-07	2.8E-08	ug/L
006	12/19/07	4th Quarter 2007	Daily	Chloride	210	150	mg/L
004	01/05/08	1st Quarter 2008	Daily	TCDD	6.53E-07	2.8E-08	ug/L
018	01/23/08	1st Quarter 2008	Daily	TCDD	5.15E-07	2.8E-08	ug/L
004	01/24/08	1st Quarter 2008	Daily	TCDD	3.26E-07	2.8E-08	ug/L
011	01/27/08	1st Quarter 2008	Daily	TCDD	7.04E-07	2.8E-08	ug/L
011	01/27/08	1st Quarter 2008	Monthly	TCDD	7.04E-07	1.4E-08	ug/L
011	02/03/08	1st Quarter 2008	Daily	Fe	0.72	0.3	mg/L
018	02/03/08	1st Quarter 2008	Daily	Fe	0.66	0.3	mg/L
018	02/03/08	1st Quarter 2008	Daily	TCDD	3.41E-07	2.8E-08	ug/L
004	02/24/08	1st Quarter 2008	Daily	TCDD	3.80E-07	2.8E-08	ug/L
018	02/24/08	1st Quarter 2008	Daily	TCDD	4.41E-07	2.8E-08	ug/L
006	11/26/08	4th Quarter 2008	Daily	pH	6	6.5-8.5	pH units
004	12/15/08	4th Quarter 2008	Daily	pH	9.1	6.5-8.5	pH units
004	02/06/09	1st Quarter 2009	Daily	TCDD	6.10E-07	2.8E-08	ug/L
018	02/16/09	1st Quarter 2009	Daily	Mn	140	50	ug/L
011	02/16/09	1st Quarter 2009	Daily	Mn	150	50	ug/L
004	02/16/09	1st Quarter 2009	Daily	TCDD	3.60E-07	2.8E-08	ug/L
011	02/16/09	1st Quarter 2009	Daily	Fe	11	0.3	mg/L

Outfall	Date	Monitoring Period	Violation Type	Parameter	Reported Value	Permit Limit	Units
018	02/16/09	1st Quarter 2009	Daily	Fe	12	0.3	mg/L
011	02/16/09	1st Quarter 2009	Daily	TCDD	1.40E-06	2.8E-08	ug/L
018	02/16/09	1st Quarter 2009	Daily	TCDD	2.60E-06	2.8E-08	ug/L
011	02/28/09	1st Quarter 2009	Monthly	Zn	60	54	ug/L
011	02/28/09	1st Quarter 2009	Monthly	TCDD	1.40E-06	1.4E-08	ug/L

The violations noted are being evaluated for enforcement action.

E. Planned Changes

Not applicable

III. APPLICABLE PLANS, POLICIES, AND REGULATIONS

The requirements contained in the proposed Order are based on the requirements and authorities described in this section.

A. Legal Authorities

This Order is issued pursuant to section 402 of the federal Clean Water Act (CWA) and implementing regulations adopted by the U.S. Environmental Protection Agency (USEPA) and chapter 5.5, division 7 of the California Water Code (commencing with section 13370). It shall serve as an NPDES permit for point source discharges from this facility to surface waters. This Order also serves as Waste Discharge Requirements (WDRs) pursuant to article 4, chapter 4, division 7 of the Water Code (commencing with section 13260).

B. California Environmental Quality Act (CEQA)

Under Water Code section 13389, this action to adopt an NPDES permit is exempt from the provisions of CEQA, Public Resources Code sections 21100 through 21177.

C. State and Federal Regulations, Policies, and Plans

1. **Water Quality Control Plans.** The Regional Water Quality Control Board (Regional Water Board) adopted a Water Quality Control Plan for the Los Angeles Region (hereinafter Basin Plan) on June 13, 1994 that designates beneficial uses, establishes water quality objectives, and contains implementation programs and policies to achieve those objectives for all waters addressed through the plan. In addition, the Basin Plan implements State Water Resources Control Board (State Water Board) Resolution No. 88-63, which established state policy that all waters, with certain exceptions, should be considered suitable or potentially suitable for municipal or domestic supply.

A number of the outfalls at SSFL discharge to the Los Angeles River via either Bell Creek or Dayton Canyon Creek. The beneficial uses applicable to Dayton Canyon Creek, Bell Creek and the Los Angeles River are as follows:

Table F-3. Basin Plan Beneficial Uses

Discharge Point	Receiving Water Name	Beneficial Use(s)
008	Dayton Canyon Creek – Hydro Unit 405.21	<u>Existing:</u> wildlife habitat <u>Intermittent:</u> groundwater recharge, contact and non contact recreation: warm freshwater habitat.
001, 002, 011, 012, 013, 014, 018, 019	Bell Creek – Hydro Unit 405.21	<u>Existing:</u> wildlife habitat <u>Intermittent:</u> groundwater recharge, contact and non contact recreation: warm freshwater habitat.
001, 002, 011, 008, 012, 013, 014, 018, 019	Los Angeles River upstream of Figueroa St. - Hydro Unit 405.21	<u>Existing:</u> groundwater recharge; contact and non-contact water recreation; warm freshwater habitat; wildlife habitat; and wetland habitat. <u>Potential:</u> industrial service supply.
001, 002, 011, 008, 012, 013, 014, 018, 019	Los Angeles River down-stream of Figueroa St. - Hydro Unit 405.15	<u>Existing:</u> groundwater recharge; contact and non-contact water recreation; and warm freshwater habitat. <u>Potential:</u> industrial service supply; and wildlife habitat.
001, 002, 011, 008, 012, 013, 014, 018, 019	Los Angeles River Estuary - Hydro Unit 405.12	Existing: industrial service supply; navigation; contact water recreation; non-contact water recreation; commercial and sport fishing; estuarine habitat; marine habitat; wildlife habitat; rare, threatened, or endangered species; migration of aquatic organisms; spawning, reproduction, and/or early development; and wetland habitat. Potential: shellfish harvesting

Dayton Canyon Creek, Bell Creek and all of the reaches of the Los Angeles River listed except for the estuary also have municipal and domestic supply (MUN) listed

in the Basin Plan as a potential beneficial use with an asterisk. This is consistent with Regional Water Board Resolution 89-03; however the Regional Water Board has only conditionally designated the MUN beneficial uses and at this time cannot establish effluent limitations designed to protect the conditional designation.

The storm water runoff, from Outfalls 003 through 007, 009, and 010, flows to the northwest and down Meir and Runkle Canyons toward Arroyo Simi. Arroyo Simi is a tributary to the Callegaus Creek. The beneficial uses for the receiving water are listed below.

Table F-3a. Basin Plan Beneficial Uses

Discharge Point	Receiving Water Name	Beneficial Use(s)
003 – 007, 009, 010	Arroyo Simi – Hydro Unit 403.62	<p><u>Existing</u>: wildlife habitat; rare, threatened, or endangered species habitat;</p> <p><u>Intermittent</u>: industrial process supply, groundwater recharge, freshwater replenishment, contact and non-contact water recreation, warm freshwater habitat.</p>
003-007, 009,010	Arroyo Las Posas – Hydro Unit 403.62	<p><u>Existing</u>: wildlife habitat</p> <p><u>Intermittent</u>: groundwater recharge, contact and non contact recreation: warm freshwater habitat.</p>

Requirements of this Order implement the Basin Plan.

13. **Thermal Plan.** The State Water Board adopted a Water Quality Control Plan for Control of Temperature in the Coastal and Interstate Water and Enclosed Bays and Estuaries of California (Thermal Plan) on May 18, 1972, and amended this plan on September 18, 1975. Requirements of this Order implement the Thermal Plan and a white paper developed by Regional Water Board staff entitled *Temperature and Dissolved Oxygen Impacts on Biota in Tidal Estuaries and Enclosed Bays in the Los Angeles Region*. The white paper evaluated the optimum temperatures for steelhead, topsmelt, ghost shrimp, brown rock crab, jackknife clam, and blue mussel. The temperature effluent limitation of 86°F that is included in this Order is reflective of the information included in the white paper.
14. **National Toxics Rule (NTR) and California Toxics Rule (CTR).** USEPA adopted the NTR on December 22, 1992, and later amended it on May 4, 1995, and November 9, 1999. About forty criteria in the NTR applied in California. On May 18, 2000, USEPA adopted the CTR. The CTR promulgated new toxics criteria for California and, in addition, incorporated the previously adopted NTR criteria that

were applicable in the state. The CTR was amended on February 13, 2001. These rules contain water quality criteria for priority pollutants.

15. **State Implementation Policy.** On March 2, 2000, the State Water Board adopted the *Policy for Implementation of Toxics Standards for Inland Surface Waters, Enclosed Bays, and Estuaries of California* (State Implementation Policy or SIP). The SIP became effective on April 28, 2000, with respect to the priority pollutant criteria promulgated for California by the USEPA through the NTR and to the priority pollutant objectives established by the Regional Water Board in the Basin Plan. The SIP became effective on May 18, 2000, with respect to the priority pollutant criteria promulgated by the USEPA through the CTR. The State Water Board adopted amendments to the SIP on February 24, 2005, that became effective on July 13, 2005. The SIP establishes implementation provisions for priority pollutant criteria and objectives and provisions for chronic toxicity control. Requirements of this Order implement the SIP.
16. **Alaska Rule.** On March 30, 2000, USEPA revised its regulation that specifies when new and revised state and tribal water quality standards (WQS) become effective for CWA purposes (40 C.F.R. § 131.21, 65 Fed. Reg. 24641 (April 27, 2000)). Under the revised regulation (also known as the Alaska rule), new and revised standards submitted to USEPA after May 30, 2000, must be approved by USEPA before being used for CWA purposes. The final rule also provides that standards already in effect and submitted to USEPA by May 30, 2000, may be used for CWA purposes, whether or not approved by USEPA.
17. **Antidegradation Policy.** Section 131.12 requires that the state water quality standards include an antidegradation policy consistent with the federal policy. The State Water Board established California's antidegradation policy in State Water Board Resolution No. 68-16. Resolution No. 68-16 incorporates the federal antidegradation policy where the federal policy applies under federal law. Resolution No. 68-16 requires that existing water quality be maintained unless degradation is justified based on specific findings. The Regional Water Board's Basin Plan implements, and incorporates by reference, both the State and federal antidegradation policies. The permitted discharge must be consistent with the antidegradation provision of section 131.12 and State Water Board Resolution No. 68-16.
18. **Anti-Backsliding Requirements.** Sections 402(o)(2) and 303(d)(4) of the CWA and federal regulations at title 40, Code of Federal Regulations¹ section 122.44(l) prohibit backsliding in NPDES permits. These anti-backsliding provisions require that effluent limitations in a reissued permit must be as stringent as those in the previous permit, with some exceptions in which limitations may be relaxed. All limits in the permit are as stringent as the previous permit.

¹ All further statutory references are to title 40 of the Code of Federal Regulations unless otherwise indicated.

D. Watershed Management Approach

The Regional Water Board has implemented a Watershed Management Approach, in accordance with *Watershed Protection: A Project Focus* (EPA841-R-95-003, August 1995), to address water quality protection in the Los Angeles Region. Programs covered under the Watershed Management Approach include regulatory (e.g., NPDES), monitoring and assessment, basin planning and water quality standards, watershed management, wetlands, TMDLs, 401 certifications, groundwater (as appropriate), and nonpoint source management activities. The Watershed Management Approach integrates the Regional Water Board's many diverse programs, particularly, permitting, planning, and other surface-water oriented programs. It emphasizes cooperative relationships between regulatory agencies, the regulated community, environmental groups, and other stakeholders in the watershed to achieve the greatest environmental improvements with the resources available. This approach facilitates a more accurate assessment of cumulative impacts of pollutants from both point and nonpoint sources.

The Los Angeles River watershed is one of the largest in the Region. The headwaters of the Los Angeles River originate in the Santa Monica, Santa Susana, and San Gabriel Mountains. The river flows through industrial and commercial areas and is bordered by rail yards, freeways, and major commercial and government buildings. The Los Angeles River tidal prism/estuary begins in Long Beach at Willow Street and runs approximately three miles before joining with Queensway Bay located between the Port of Long Beach and the City of Long Beach.

Discharges from Outfalls 001, 002, 011, 012, 013, 014, 018, and 019 enter Bell Creek, a tributary to the Los Angeles River. Storm water from Happy Valley, Outfall 008 exits the site toward Dayton Canyon Creek, which flows into Chatsworth Creek. Chatsworth Creek flows southward to Bell Creek, near the intersection of Sherman Way and Shop Avenue, and subsequently to the Los Angeles River. The area where SSFL is located is largely undeveloped. The majority of the Los Angeles River Watershed downstream of the site is considered impaired due to a variety of point and nonpoint sources.

Storm water runoff exiting the SSFL site to the north does so near the northwest site boundary from Outfalls 003 through 007, 009 and 010. The receiving water for the storm water runoff from these locations is the Arroyo Simi, a tributary of Calleguas Creek. The Calleguas Creek Watershed extends from the Santa Monica Mountains and Simi Hills in the south, to the Santa Susana Mountains, South Mountain, and Oak Ridge in the north. Land uses vary throughout the watershed. Urban developments are generally restricted to the city limits of Simi Valley, Moorpark, Thousand Oaks, and Camarillo. Agricultural activities are spread out along valleys and on the Oxnard Plain.

The storm water discharge exits the site and travels down Meier and Runkle Canyons toward the Arroyo Simi. Most of the land use around the facility is open area. Overall the Calleguas Creek Watershed is considered an impaired watershed. It appears that the sources of many of these pollutants are agricultural activities. Approximately fifty percent of the watershed is still open space although there is a severe lack of benthic

and riparian habitat present. The discharge, when it is sufficient to reach the Arroyo Simi, enters it in Reach 1 – Hydrological Unit 403.62.

E. Impaired Water Bodies on CWA 303(d) List

Section 303(d) of the CWA requires states to identify specific water bodies where water quality standards are not expected to be met after implementation of technology-based effluent limitations on point sources. For all 303(d)-listed water bodies and pollutants, the Regional Water Board plans to develop and adopt TMDLs that will specify waste load allocations (WLAs) for point sources and load allocations (LAs) for non-point sources, as appropriate.

The USEPA approved the State's 2006 303(d) list of impaired water bodies on June 28, 2007. Certain receiving waters in the Los Angeles and Ventura County watersheds do not fully support beneficial uses and therefore have been classified as impaired on the 2006 303(d) list and have been scheduled for TMDL development. The 2006 State Water Board's California 303(d) List classifies Bell Creek and the Los Angeles River (Reach 6) as impaired. The pollutants/stressors listed include: coliform bacteria, 1,1-dichloroethane, trichloroethylene, and tetrachloroethylene. The TMDLs adopted for the Los Angeles River and its tributaries applies to discharges from the SSFL Outfalls 001, 002, 008, 011 - 014, 018 and 019.

Arroyo Simi the receiving water for storm water discharges from the northern boundary of the SSFL is in the Calleguas Creek Watershed. The Arroyo Simi is in Calleguas Creek Reach 7, which appears on the State's 2006 303(d) list. The stressors listed include boron, chloride, fecal coliform, sulfates, and total dissolved solids. The TMDLs adopted for Calleguas Creek are applicable for Arroyo Simi and for the discharges from SSFL Outfalls 003 – 007, 009, and 010.

F. Total Maximum Daily Loads (TMDL)

TMDLs have been developed for a number of the constituents on California State Water Board 2006 303(d) list. When each TMDL is complete the Regional Water Board will adopt water quality based effluent limits (WQBELs) consistent with the corresponding WLAs.

Los Angeles River Nitrogen (Nutrients) TMDL. The TMDL for Nitrogen (nutrients) in the Los Angeles River received Regional Water Board approval on July 10, 2003 (Resolution No. 03-009). The Regional Water Board filed a Notice of Decision with the California Resources Agency on March 23, 2004 and the TMDL was effective as of that date. Subsequently, Resolution 03-009 which revised the interim effluent limits for ammonia was adopted by the Regional Water Board on December 4, 2003 (Resolution No. 2003-016). The effective date for the Order was September 27, 2004.

The TMDL includes numeric targets for ammonia as nitrogen (NH₃-N), Nitrate-nitrogen and nitrite-Nitrogen within Reach 5 (within Sepulveda Basin) Reach 3 (Riverside Drive to Figueroa Street), and the Burbank Western Channel. Waste loads are allocated to minor point sources in these reaches that are enrolled in industrial and construction storm water permits.

Los Angeles River Metals TMDL. The TMDL for metals in the Los Angeles (LA) River was approved by the Regional Water Board during the June 2, 2005, hearing (Resolution No. 2005-006). An amendment to the metals TMDL was adopted by the Regional Water Board on September 6, 2007.

The TMDL includes numeric target that are based on objectives established by USEPA in the CTR. Targets for copper, lead, zinc, and/or selenium (total recoverable) are established for designated reaches of the Los Angeles River. Separate water quality targets are established for dry and wet weather discharges.

The TMDL for metals in the Los Angeles River includes an implementation schedule for non-storm water NPDES permits (including POTWs, other major, minor, and general permits). SSFL is included in this group of permittees. The implementation schedule states that NPDES permits shall achieve waste load allocations, which shall be expressed as NPDES WQBELs. Compliance schedules may allow up to five years in individual NPDES permits to meet the requirements.

Discharges from SSFL, of wastewater and of storm water runoff only exiting the site enter Bell Creek or Dayton Canyon Creek. Dry-weather numeric water quality targets for copper, lead, and selenium are established for Bell Creek in the TMDL. WLAs are assigned to all point source discharges that flow to Bell Creek and tributaries to Bell Creek. Wet-weather numeric targets for cadmium, copper, lead, and zinc are established for Los Angeles River Reach 1 in the TMDL. WLAs are assigned to all point source discharges to the Los Angeles River Reach 1 and all upstream reaches and tributaries to Reach 1 (including Bell Creek and tributaries to Bell Creek). Hence, effluent limits for cadmium, copper, lead, zinc, and selenium in discharges to Bell Creek, Dayton Canyon Creek, or any tributaries of the Los Angeles River will be based on WLAs established by the TMDL or existing permit limits, whichever are more protective.

Los Angeles River Trash TMDL: The LA River Trash TMDL was adopted by the Regional Water Board on September 19, 2001. The TMDL established a numeric target of zero trash in the river to be implemented via storm water permits in a phased reduction for a period of ten years. The TMDL became effective on August 28, 2002.

There were a number of challenges to the LA River Trash TMDL. The consideration of the challenges resulted in a requirement that the TMDL be set aside and not implemented until the California Environmental Quality Act (CEQA) requirements had been satisfied. On June 8, 2006, the Los Angeles Regional Water Quality Control Board adopted a resolution to set aside the adopted TMDL. Subsequently, the Los Angeles River trash TMDL was adopted by the Regional Water Board on August 9, 2007. The State Board approved the TMDL with Resolution 2008-0024 on April 15, 2008. OAL approved it on July 1, 2008, and USEPA approved it on July 24, 2008.

This TMDL will be implemented through the Municipal Separate Storm Sewer Systems (MS4) NPDES Permit Program. Therefore this permit does not include any criteria associated with this TMDL.

Storm water only discharges from the northern portion of the SSFL site enter the Calleguas Creek Watershed via tributaries to the Arroyo Simi. A number of TMDLs have been developed for Calleguas Creek. A summary of the applicable TMDLs follows.

Calleguas Creek Salts TMDL (Resolution No. R4-2007-016): The Calleguas Creek Watershed Salts TMDL was adopted by the Regional Water Board on October 4, 2007. After approvals by the State Board, OAL, and US EPA the TMDL became effective on December 2, 2008. The TMDL includes interim and final dry weather WLAs for urban runoff. These WLAs are not implemented in this permit since there are no discharges to the Arroyo Simi during dry weather. The TMDL also includes final WLAs for other NPDES dischargers which are concentration-based WLAs that are equivalent to the Basin Plan objectives for these constituents. These Basin Plan objectives are included in this permit.

Calleguas Creek Nitrogen Compounds and Related Effects TMDL. The TMDL for Nitrogen Compounds and Related effects in Calleguas Creek was adopted by the Regional Water Board on October 24, 2002 (Resolution No. 2002-017). The TMDL became effective on July 16, 2003.

The WLAs for Calleguas Creek Nitrogen TMDL was revised by adoption of Regional Water Board Resolution No. R4-2008-009 on September 11, 2008. The TMDL was approved by State Board (State Board Resolution No. 2009-0052), OAL (OAL File No. 2009-0818-02 S) and EPA on June 16, 2009, October 5, 2009, and October 15, 2009, respectively. The TMDL includes WLAs for ammonia as nitrogen, nitrite as nitrogen, nitrate as nitrogen, and nitrate + nitrite as nitrogen for the POTWs in the watershed. The revision also includes LAs for agriculture and other nonpoint sources for nitrate + nitrite as nitrogen.

The first and the revised TMDLs included WLAs for the publicly owned treatment works (POTWs) located in the watershed and do not include WLAs for other point sources. Consequently, this Order does not include criteria based on this TMDL.

Calleguas Creek Toxicity TMDL: The TMDL for toxicity, chlorpyrifos, and diazinon in the Calleguas Creek, its tributaries and Mugu Lagoon (Calleguas Creek Toxicity TMDL) (Resolution No. R4-2005-009) was adopted by the Regional Water Board on July 7, 2005. The TMDL became effective on March 24, 2006. The approved TMDL addresses impairment to water quality due to elevated levels of chlorpyrifos, diazinon, other pesticides and/or other toxicants. The TMDL includes numeric targets, WLAs and load allocations for toxicity, chlorpyrifos and diazinon. The toxicity wasteload allocation of 1.0 TU_c is included for the major point sources (POTWs) and minor point sources. The implementation procedure specifies that the toxicity wasteload allocation be implemented as a trigger. The TMDL also includes WLAs for chlorpyrifos and diazinon. The appropriate WLAs have been translated into permit limits and included in this Order.

Calleguas Creek OC Pesticides & PCBs TMDL. Resolution No. R4-2005-0010, a TMDL for Organochlorine (OC) Pesticides and Polychlorinated Biphenyls (PCBs) and Siltation in Calleguas Creek, its tributaries, and Mugu Lagoon, was approved by the Regional Water Board on July 7, 2005. The TMDL establishes water column targets, fish tissue targets, and sediment targets to ensure the protection of beneficial uses. The WLAs for OC pesticides and PCBs in sediment have been translated directly into ambient contaminant concentrations in the sediment of Arroyo Simi. Those ambient contaminant concentrations will be compared directly to sediment concentrations measured in the samples collected to determine compliance. The WLAs in the water column are translated into effluent limitations and are included as receiving water effluent limits. The Discharger samples the OC pesticides in sediment in Frontier Park. Monitoring for OC pesticides in the receiving water also occurs in the Frontier Park vicinity within the Arroyo Simi.

Calleguas Creek Watershed Metals TMDL. Resolution R4-2006-012, the TMDL for metals and selenium for Calleguas Creek, its tributaries and Mugu Lagoon became effective on March 26, 2007. The TMDL includes final WLA for wet weather total recoverable copper and nickel. A concentration-based WLA applied during both wet and dry weather was also included for mercury.

Discharges from the SSFL site (Outfalls 003 through 007, 009, and 010) enter Calleguas Creek in Reach 7, which was noted as Arroyo Simi Reaches 1 and 2 in the 1998 303(d) List. Discharges from these outfalls only occur during rain events. Therefore no dry weather WLAs have been developed for this reach as it is not on the 303(d) list. The final WLA developed for mercury was 0.051 µg/L. That WLA is based on the CTR criteria. The mercury WLA included in the TMDL was used to develop a daily maximum effluent limit, which has been implemented at Outfalls 003 through 007, 009, 010. Only the daily maximum is included since discharges only occur during rain events. Rain events in southern California are infrequent and seasonal.

Final WLAs for wet weather daily maximum concentrations of copper and nickel are stipulated as 31.0 and 958 µg/L, respectively. The daily maximum limit for copper is included in the permit. The TMDL-based daily maximum for nickel (958 µg/L), which was developed to protect aquatic life in the lower Calleguas Creek and Mugu Lagoon, is greater than the Title 22-based MCL limit of 100 µg/L. Since the groundwater basin below the Arroyo Simi has municipal and domestic supply as an existing beneficial use and Arroyo Simi has groundwater recharge as an intermittent beneficial use, the effluent limitation implemented must be protective of both groundwater recharge and of the downstream aquatic life beneficial uses. Therefore, the 100 µg/L effluent limitation which is protective of the beneficial uses of Arroyo Simi and the groundwater basin below it, has been implemented for nickel.

Revolon Slough & Beardsley Wash Trash TMDL. This TMDL was adopted by the Regional Water Board on June 7, 2007 and became effective on March 6, 2008. Since discharges from SSFL do not enter Revolon Slough or Beardsley Wash criteria included in the TMDL have not been implemented in this Order.

G. Title 22 of the California Code of Regulations.

The California Department of Public Health established primary and secondary maximum contaminant levels (MCLs) for a number of chemical and radioactive contaminants. The MCLs can be found in Title 22, California Code of Regulations (Title 22). Chapter 3 of the Basin Plan incorporates portions of Title 22 by reference. Narrative objectives require the ground waters shall not contain taste or odor-producing substances in concentrations that affect beneficial uses. The secondary MCLs in Title 22 are designed to ensure that the water's taste and odor does not affect its suitability as a drinking water source. Title 22 MCLs have been incorporated into NPDES permits and Non-Chapter 15 WDRs to protect the municipal and domestic supply (MUN) and groundwater recharge (GWR), where the underlying groundwater has a designated MUN beneficial use.

Groundwater Recharge. Sections of Bell Creek and Arroyo Simi, near the SSFL discharge points, are designated as GWR indicating that groundwater recharge is a beneficial use. Surface water from Bell Creek enters the Los Angeles River Watershed. The headwaters of the Los Angeles River originate in the Santa Monica, Santa Susana, and San Gabriel Mountains. Four basins in the San Fernando Valley area contain substantial deep groundwater reserves and are recharged mainly through runoff and infiltration.

Surface water discharges from the northwest edge of SSFL are directed to Arroyo Simi, a tributary located in the Calleguas Creek Watershed. Supplies of groundwater are critical to agricultural operations and industry (sand and gravel mining) in the watershed.

Moreover, much of the population in the watershed relies upon groundwater for drinking. Since groundwater from these basins is used to provide drinking water to a large portion of the population, Title-22-based limits are needed to protect that drinking water supply. By limiting the contaminants in SSFL discharges, the amount of pollutants entering the surface waters and groundwater basins are correspondingly reduced. Once groundwater basins are contaminated, it may take years to clean them up depending on the pollutants. Compared to surface water pollution, investigation and remediation of groundwater are often more difficult, costly, and extremely slow. For these reasons Title 22-based limits will remain in the NPDES permit where there is reasonable potential.

H. Perchlorate.

Perchlorate and its salts are used in, but not limited to, solid propellant for rockets, missiles, and fireworks. The defense and aerospace industries purchase more than 90 percent of all the perchlorate manufactured. Perchlorate has historically been used at SSFL and thus is considered a chemical of concern at the site. Monitoring data collected during the tenure of the current permit indicates that perchlorate was present in the storm water runoff in Happy Valley and it has been detected in some of the groundwater wells utilized in the cleanup operations ongoing with DTSC oversight.

Perchlorate can interfere with iodide uptake by the thyroid gland; this can result in a decrease in the production of thyroid hormones, which are needed for prenatal and

postnatal growth and development, as well as for normal body metabolism. Neither, the CTR, NTR, or the Basin Plan has requirements stipulated for perchlorate. The June 25, 2007, R-16-04 amended California Code of Regulations, Title 22, Chapter 15, Article 2, Section 64431 to include a primary MCL for perchlorate of 6 µg/L. That MCL has been included as an effluent limit for perchlorate in this order.

I. Other Plans, Polices and Regulations

Not applicable

IV. RATIONALE FOR EFFLUENT LIMITATIONS AND DISCHARGE SPECIFICATIONS

The CWA requires point source dischargers to control the amount of conventional, non-conventional, and toxic pollutants that are discharged into the waters of the United States. The control of pollutants discharged is established through effluent limitations and other requirements in NPDES permits. There are two principal bases for effluent limitations in the Code of Federal Regulations: section 122.44(a) requires that permits include applicable technology-based limitations and standards; and section 122.44(d) requires that permits include water quality-based effluent limitations to attain and maintain applicable numeric and narrative water quality criteria to protect the beneficial uses of the receiving water.

The SSFL discharges storm water runoff and treated groundwater from the site which is located at the top of Woolsey Canyon, in the Simi Hills. The historical operations of Boeing and its predecessors' included research, development, assembly, disassembly, and testing of nuclear reactors, rocket engines, and chemical lasers. DOE conducted past operations in research and development of energy related programs, and seismic testing experiments. The previous Order established effluent limitations for pH, temperature, TSS, BOD, oil and grease, turbidity, settleable solids, sulfides, and residual chlorine, due to the fact that these are the typical pollutants of concern in discharges from backwash water and drainage from settling basins. Effluent limitations for TDS, chloride, nitrate plus nitrite (as Nitrogen), sulfate, and residual chlorine, are based on water quality objectives contained in the Basin Plan. Effluent limitations for some priority pollutants are based on an analysis of effluent monitoring data and the applicable water quality criteria.

Generally, mass-based effluent limitations ensure that proper treatment, and not dilution, is employed to comply with the final effluent concentration limitations. Section 122.45(f)(1) requires that all permit limitations, standards or prohibitions be expressed in terms of mass units except under the following conditions: (1) for pH, temperature, radiation or other pollutants that cannot appropriately be expressed by mass limitations; (2) when applicable standards or limitations are expressed in terms of other units of measure; or (3) if in establishing technology-based permit limitation on a case-by-case basis limitation based on mass are infeasible because the mass or pollutant cannot be related to a measure of production. The limitations, however, must ensure that dilution will not be used as a substitute for treatment.

A. Discharge Prohibitions

The discharge prohibitions are based on the requirements of the Basin Plan, State Water Board's plans and policies, the Water Code, and previous permit provisions.

They are also consistent with the requirements set for other discharges to the Los Angeles River and Calleguas Creek watersheds that are regulated by NPDES permits.

B. Technology-Based Effluent Limitations

1. Scope and Authority

Section 301(b) of the CWA and implementing USEPA permit regulations at section 122.44, title 40 of the Code of Federal Regulations, require that permits include conditions meeting applicable technology-based requirements at a minimum, and any more stringent effluent limitations necessary to meet applicable water quality standards. The discharge authorized by this Order must meet minimum federal technology-based requirements based on Best Professional Judgment (BPJ) in accordance with Part 125, section 125.3.

The CWA requires that technology-based effluent limitations be established based on several levels of controls:

- a. Best practicable treatment control technology (BPT) represents the average of the best performance by plants within an industrial category or subcategory. BPT standards apply to toxic, conventional, and non-conventional pollutants.
- b. Best available technology economically achievable (BAT) represents the best existing performance of treatment technologies that are economically achievable within an industrial point source category. BAT standards apply to toxic and non-conventional pollutants.
- c. Best conventional pollutant control technology (BCT) represents the control from existing industrial point sources of conventional pollutants including BOD, TSS, fecal coliform, pH, and oil and grease. The BCT standard is established after considering the “cost reasonableness” of the relationship between the cost of attaining a reduction in effluent discharge and the benefits that would result, and also the cost effectiveness of additional industrial treatment beyond BPT.
- d. New source performance standards (NSPS) represent the best available demonstrated control technology standards. The intent of NSPS guidelines is to set limitations that represent state-of-the-art treatment technology for new sources.

The CWA requires USEPA to develop effluent limitations, guidelines and standards (ELGs) representing application of BPT, BAT, BCT, and NSPS. Section 402(a)(1) of the CWA and section 125.3 of the Code of Federal Regulations authorize the use of best professional judgment (BPJ) to derive technology-based effluent limitations on a case-by-case basis where ELGs are not available for certain industrial categories and/or pollutants of concern. Where BPJ is used, the permit writer must consider specific factors outlined in section 125.3.

2. Applicable Technology-Based Effluent Limitations

No ELGs are available for this facility. Therefore, this Order includes technology-based effluent limitations based on BPJ in accordance with 40 CFR section 125.3. Effluent limitations for TSS, BOD, oil and grease, settleable solids, and sulfides have been carried over from the existing Order (No. R4-2009-0058), since they continue to be appropriate for the discharge.

The previous Order required the Discharger to develop and implement a Storm Water Pollution Prevention Plan (SWPPP). The SWPPP currently outlines site-specific management processes for minimizing storm water runoff contamination and for preventing contaminated storm water runoff from being discharged to the receiving water. This Order will continue to require that the Discharger update and continue to implement the site specific SWPPP (see Attachment G).

The Regional Water Board will require the Discharger to update their Best Management Practices. The purpose of BMPs is to establish site-specific procedures that will ensure proper operation and maintenance of equipment and storage areas, to ensure that unauthorized non-storm water discharges (i.e., spills) do not occur at the Facility.

The combination of the SWPPP and BMPs, and the Order limitations based on past performance and reflecting BPJ will serve as the equivalent of technology-based effluent limitations, in the absence of established ELGs, in order to carry out the purposes and intent of the CWA.

**Table F-4. Summary of Technology-based Effluent Limitations/Benchmarks*
Outfalls 001-002, 011-014, 018, 019**

Parameter	Units	Effluent Limitations	
		Average Monthly ¹	Maximum Daily
BOD ₅ @ 20°C	mg/L	20	30
Oil and Grease	mg/L	10	15
Total Suspended Solids	mg/L	15	45
Settleable Solids	ml/L	0.1	0.3

* A “benchmark” is a water quality based effluent limit or a performance based limit that is used to evaluate the performance of best management practices (BMPs) with regard to the removal of contaminants present in the discharge. In this permit, the benchmarks are established based on water quality based effluent limitations. Exceedance of a benchmark triggers an evaluation of the BMPs implemented at the site. The evaluation may determine that the BMPs require augmentation, upgrading, or replacement. If so, the Discharger must develop a plan to implement the required upgrades and report to the Regional Water Board staff within 60 days of the reported exceedance. The Discharger will continue monitoring as directed in the Monitoring and Reporting Program.

1. Outfall 019 only

Table F-4a. Summary of Technology-based Effluent Limitations Outfalls 003 - 010

Parameter	Units	Effluent Limitations Maximum Daily
Oil and Grease	mg/L	15
Settleable Solids	ml/L	0.3

C. Water Quality-Based Effluent Limitations (WQBELs)

1. Scope and Authority

Section 301(b) of the CWA and section 122.44(d) require that permits include limitations more stringent than applicable federal technology-based requirements where necessary to achieve applicable water quality standards.

Section 122.44(d)(1)(i) mandates that permits include effluent limitations for all pollutants that are or may be discharged at levels that have the reasonable potential to cause or contribute to an exceedance of a water quality standard, including numeric and narrative objectives within a standard. Where reasonable potential has been established for a pollutant, but there is no numeric criterion or objective for the pollutant, water quality-based effluent limitations (WQBELs) must be established using: (1) USEPA criteria guidance under CWA section 304(a), supplemented where necessary by other relevant information; (2) an indicator parameter for the pollutant of concern; or (3) a calculated numeric water quality criterion, such as a proposed state criterion or policy interpreting the state’s narrative criterion, supplemented with other relevant information, as provided in section 122.44(d)(1)(vi).

The process for determining reasonable potential and calculating WQBELs when necessary is intended to protect the designated uses of the receiving water as specified in the Basin Plan, and achieve applicable water quality objectives and criteria that are contained in other state plans and policies, or any applicable water quality criteria contained in the CTR and NTR.

2. Applicable Beneficial Uses and Water Quality Criteria and Objectives

As noted in section II of the Limitations and Discharge Requirements, the Regional Water Board adopted a Basin Plan that designates beneficial uses, establishes water quality objectives, and contains implementation programs and policies to achieve those objectives for all waters addressed through the Basin Plan. The beneficial uses applicable to Bell Creek, Dayton Canyon Creek and the Los Angeles River are summarized in section IV.C of this Fact Sheet. The beneficial uses applicable to Arroyo Simi and subsequent tributaries to Calleguas Creek are also summarized in section IV.C. The Basin Plan includes both narrative and numeric water quality objectives applicable to the receiving water.

Priority pollutant water quality criteria in the CTR are applicable to the receiving waters (Bell Creek, Dayton Canyon Creek, and Arroyo Simi). The CTR contains both saltwater and freshwater criteria. Because a distinct separation generally does not exist between freshwater and saltwater aquatic communities, the following apply, in accordance with section 131.38(c)(3), freshwater criteria apply at salinities of 1 part per thousand (ppt) and below at locations where this occurs 95 percent or more of the time. The CTR criteria for fresh water or human health for consumption of water and organisms, whichever is more stringent, are used to prescribe the effluent limitations in this Order to protect the beneficial uses of Bell Creek and Dayton Canyon Creek, tributaries to the Los Angeles River, and to Arroyo Simi, waters of the United States in the vicinity of the discharge.

Some water quality criteria are hardness dependent. The Discharger provided hardness data for the receiving water during this permit term. The data indicates that the 100 mg/L as CaCO₃ for hardness continues to be representative of the discharge from the Facility. The 100 mg/L hardness has been used to develop the total recoverable water quality criteria.

Table F-5a and F-5b summarize the applicable numeric water quality criteria/objective for priority pollutants and non-priority pollutants reported in detectable concentrations in the effluent or receiving water. These criteria were used in conducting the RPA for this Order.

Table F-5a. Applicable Water Quality Criteria

CTR No.	Constituent	Selected Criteria µg/L	CTR/NTR Water Quality Criteria					
			Freshwater		Saltwater		Human Health for Consumption of:	
			Acute	Chronic	Acute	Chronic	Water & Organisms	Organisms only
			µg/L	µg/L	µg/L	µg/L	µg/L	µg/L
1	Antimony	6 ¹	--	--	N/A	N/A	4,300	
2	Arsenic	10 ²	340	150			--	
3	Beryllium	4 ¹	--	--			--	
4	Cadmium	2.2	4.3	2.2			--	
5a	Chromium (III)	180	550	180			--	
5b	Chromium (VI)	11	16	11			--	
6	Copper	9.0	13	9.0			--	
7	Lead	2.5	65	2.5			--	
8	Mercury	0.051	--	--			0.051	
9	Nickel	52	470	52			4,600	
10	Selenium	5.0	--	--			--	
11	Silver	3.4	3.4	--			--	
12	Thallium	6.3	--	--			6.3	
13	Zinc	2.0 ¹	120	90			--	
14	Cyanide	5.2	22	5.2			220,000	
16	2,3,7,8-TCDD	1.4E-08	--	--			1.4E-08	

CTR No.	Constituent	Selected Criteria	CTR/NTR Water Quality Criteria					
			Freshwater		Saltwater		Human Health for Consumption of:	
			Acute	Chronic	Acute	Chronic	Water & Organisms	Organisms only
			µg/L	µg/L	µg/L	µg/L	µg/L	µg/L
30	1,1-Dichloroethylene	3.2	--	--				3.2
43	Trichloroethylene	5 ¹	--	--				81
53	Pentachlorophenol	8.2	19	15				8.2
55	2,4,6-Trichlorophenol	6.5	--	--				6.5
68	Bis(2-ethylhexyl)phthalate	5.9	--	--				5.9
82	2,4-Dinitrotoluene	9.1	--	--				9.1
96	N-Nitrosodimethylamine	8.1	--	--				8.1
103	Alpha-BHC	0.013	--	--				0.013
	Perchlorate	6 ³	--	--				--
	Radioactivity							
	Gross Alpha (pCi/L)	15 ¹	--	--				--
	Gross Beta (pCi/L)	50 ¹	--	--				--
	Combined Radium-226 & Radium-228 (pCi/L)	5 ¹	--	--				--
	Tritium (pCi/L)	20,000 ¹	--	--				--
	Strontium-90 (pCi/L)	8 ¹	--	--				--

"N/A" indicates the receiving water body is not characterized as saltwater, nor are the water quality criteria for the protection of human health for the consumption of organisms (only) applicable.

¹ Basin Plan-Title 22 criteria.

² USEPA MCL

³ CA MCL

Numeric criterion for TCDD equivalents (Dioxin – TEQ):

The CTR establishes a numeric water quality objective for 2,3,7,8-tetrachlorinated dibenzo-p-dioxin (2,3,7,8-TCDD) of 1.4×10^{-8} µg/L for the protection of human health, when aquatic organisms are consumed. When CTR was promulgated, USEPA stated its support of the regulation of other dioxin and dioxin-like compounds through the use of toxicity equivalencies (TEQs) in NPDES permits. For California waters, USEPA stated specifically, "if the discharge of dioxin or dioxin-like compounds has reasonable potential to cause or contribute to a violation of a narrative criterion, numeric water quality-based effluent limitations for dioxin or dioxin-like compounds should be included in NPDES permits and should be expressed using a TEQ scheme" [65 Fed. Reg. 31682, 31695 (2000)]. This procedure, developed by the World Health Organization (WHO) in 1988, uses a set of toxicity equivalency factors (TEFs) to convert the concentration of any congener of dioxin or furan into an equivalent concentration of 2,3,7,8-TCDD. When the CTR was promulgated, USEPA also stated that the Agency will continue to assess the risks posed by dioxin to public health and the water quality criteria for dioxin that it had promulgated. To determine if the discharge of dioxin or dioxin-like compounds from the Facility has reasonable potential to cause or contribute to a violation of the Basin Plan's narrative water quality objective regarding bioaccumulation, Regional

Water Board staff has therefore used TEFs to express the measured concentrations of 16 dioxin congeners in effluent and background samples as 2,3,7,8-TCDD. These “equivalent” concentrations are then compared to the numeric criterion, established by the CTR for 2,3,7,8-TCDD of 1.4×10^{-8} µg/L.

Dioxin-TEQ (TCDD – equivalencies) values reflect the combined effect of numerous dioxin and furan compounds (congeners). The effluent limits implement the *Los Angeles Region (Region 4) Water Quality Control Plan's* (Basin Plan's) bioaccumulation objective:

Toxic pollutants shall not be present at levels that will bioaccumulate in aquatic life to levels which are harmful to aquatic life or human health.

According to 40 CFR 122.44(d), where reasonable potential exists for a discharge to cause or contribute to violations of water quality objectives, water quality-based effluent limits must be established. If the potentially violated objective is narrative, the narrative objective must be translated into an effluent limitation. The dioxin-TEQ effluent limitations in the permit are numeric translations of the Basin Plan narrative bioaccumulation objective.

The translations are based on relevant scientific information used to weight the congener concentrations with respect to their relative toxicities compared to the toxicity of a particular dioxin congener: 2,3,7,8-tetrachlorinated dibenzo-p-dioxin (2,3,7,8-TCDD). The World Health Organization developed toxicity equivalency factors (TEFs) to convert congener concentrations into equivalent concentrations of 2,3,7,8-TCDD, which when added together are expressed as dioxin-TEQ. The *Policy for Implementation of Toxics Standards for Inland Surface Waters, Enclosed Bays, and Estuaries of California* (State Implementation Policy) specifies that the World Health Organization's 1998 TEFs are to be used to calculate dioxin-TEQ. To complete the translation of the Basin Plan's narrative bioaccumulation objective into a numeric effluent limit, dioxin-TEQ limits are derived from the California Toxic Rule (40 CFR 131) numeric water quality objective for 2,3,7,8-TCDD (numeric objectives do not exist for the other congeners).

In February 2008, the San Francisco Estuary Institute convened an expert panel to provide an unbiased review and analysis of available information regarding San Francisco Bay dioxins and furans. Representatives of the Regional Water Board, the U.S. Environmental Protection Agency, the Bay Area Clean Water Agencies, and others with expertise in the field participated. The panel's recommendations included the following:

- Apply both TEFs and BEFs to dioxin and furan concentrations when calculating dioxin-TEQ; and
- Do not use dioxin and furan congener concentrations reported below MLs when computing dioxin-TEQ.

Bioaccumulation Equivalency Factors (BEFs)

The different dioxin and furan congeners exhibit different levels of toxicity, they also exhibit different levels of bioaccumulation potential. To account for the different levels of bioaccumulation potential, each congener may be assigned a BEF relative to 2,3,7,8-TCDD. This is comparable to the TEFs that account for relative differences in toxicities. The BEFs shown in Table F-5b correspond to the differences in biological uptake from the water column for the various dioxin congeners. They come from the Great Lakes Water Quality Initiative.

In 1995, the U.S. Environmental Protection Agency adopted the approach of using both TEFs and BEFs to calculate dioxin-TEQ for the Great Lakes System (40 CFR 132, Appendix F). In the absence of site-specific BEFs, the U.S. Environmental Protection Agency supports the use of national BEFs, stating, "...EPA believes that national bioaccumulation factors are broadly applicable to sites throughout the United States and can be applied to achieve an acceptable degree of accuracy when estimating bioaccumulation potential at most sites." In its *Great Lakes Water Quality Initiative Technical Support Document for the Procedure to Determine Bioaccumulation Factors* (EPA-820-B-95-005), the U.S. Environmental Protection Agency states, "Limited comparison to BEFs calculated from data obtained for other ecosystems confirms these bioaccumulation potential differences for [dioxins and furans] for fish in ecosystems outside the Great Lakes." Recently, the U.S. Environmental Protection Agency and the Regional Water Board incorporated the national BEFs into the dioxin-TEQ calculations required for the NPDES permit for the City and County of San Francisco's Oceanside Water Pollution Control Plant (Order Number R2-2009-062).

The San Francisco Estuary Institute's expert panel concluded that, if suitable data are unavailable to derive site-specific BEFs for the San Francisco Bay Region, use of the BEFs derived for the Great Lakes System is preferable to omitting BEFs altogether. The panel concluded that, because BEFs for the congeners most commonly detected in wastewater can be as low as 0.01, calculating dioxin-TEQ without BEFs (the current practice) may mischaracterize the significance of dioxin and furan discharges by as much as two orders of magnitude. Therefore, for the purpose of determining compliance with effluent limits, this Order requires the Dischargers to calculate and report dioxin-TEQ using the following formula, where the TEFs and BEFs are as listed in Table F-5b:

$$\text{Dioxin-TEQ} = \sum (C_x \times \text{TEF}_x \times \text{BEF}_x)$$

Table F-5b. Toxicity Equivalency Factors and Bioaccumulation Equivalency Factors

Dioxin or Furan Congener	Minimum Level (pg/L)	Toxicity Equivalency Factor (TEF)	Bioaccumulation Equivalency Factor (BEF)
2,3,7,8-TCDD	10	1.0	1.0
1,2,3,7,8-PeCDD	50	1.0	0.9
1,2,3,4,7,8-HxCDD	50	0.1	0.3
1,2,3,6,7,8-HxCDD	50	0.1	0.1
1,2,3,7,8,9-HxCDD	50	0.1	0.1
1,2,3,4,6,7,8-HpCDD	50	0.01	0.05
OCDD	100	0.0001	0.01
2,3,7,8-TCDF	10	0.1	0.8
1,2,3,7,8-PeCDF	50	0.05	0.2
2,3,4,7,8-PeCDF	50	0.5	1.6
1,2,3,4,7,8-HxCDF	50	0.1	0.08
1,2,3,6,7,8-HxCDF	50	0.1	0.2
1,2,3,7,8,9-HxCDF	50	0.1	0.6
2,3,4,6,7,8-HxCDF	50	0.1	0.7
1,2,3,4,6,7,8-HpCDF	50	0.01	0.01
1,2,3,4,7,8,9-HpCDF	50	0.01	0.4
OCDF	100	0.0001	0.02

where:

C_x = concentration of dioxin or furan congener x

TEF_x = TEF for congener x

BEF_x = BEF for congener x

Minimum Levels

For purposes of laboratory analysis, reporting, and compliance, the minimum level (ML) is the concentration at which the entire analytical system gives a recognizable signal and acceptable calibration point. Below the ML, detected concentrations can sometimes be estimated, but not with sufficient analytical confidence for regulatory compliance purposes. Currently, the Dischargers analyze dioxin and furan congeners in wastewater using the latest version of U.S. Environmental Protection Agency Method 1613 (*Tetra- through Octa-Chlorinated Dioxins and Furans by Isotope Dilution HRGC/HRMS*, USEPA 1994). Many permits set forth the dioxin and furan MLs for reporting and compliance

purposes as equal to one half the default MLs specified in Method 1613. This Order revises the dioxin and furan MLs to be consistent among all permits and with Method 1613.

This Order also requires the Dischargers to exclude estimated congener concentrations below MLs when calculating dioxin-TEQ for the purpose of determining compliance with effluent limits. When a dioxin or furan congener is detected below its ML, its concentration could be as high as the ML or as low as zero. Dioxin and furan concentrations measured in effluent using high-volume screening techniques have often been orders of magnitude lower than Method 1613's default MLs. Therefore, the San Francisco Estuary Institute's expert panel concluded that assuming congeners detected below MLs are present at concentrations equal to the MLs (or one half the MLs) probably mischaracterizes the significance of dioxin and furan discharges by orders of magnitude. Moreover, when calculating dioxin-TEQ, the errors associated with adding multiple estimated values compound, resulting in values too uncertain for regulatory compliance purposes. Excluding values below MLs when adding multiple data points is consistent with how the U.S. Environmental Protection Agency directs dischargers to calculate averages when some data are below practical quantitation limits (comparable to MLs). When adding values to determine averages, data points below the practical quantitation limit are to be treated as zeros ("Instructions for Completing EPA Form 3320-1" [Rev. 01/06]).

Although this Order includes the dioxin and furan MLs, the Dischargers must continue to report all measured and estimated congener concentrations with appropriate data qualifiers.

Applicable Basin Plan Criteria

For a number of constituents the Basin Plan Objectives were used to develop the current limitations. The following Table summarizes the Basin Plan Water Quality Objectives utilized in this Order.

Table F-5c. Applicable Basin Plan Numeric Water Quality Objectives

Constituent	Units	Water Quality Criteria
pH	s.u.	Between 6.5 and 8.5 at all times, ambient pH shall not be changed more than 0.2 units from natural conditions
Ammonia	mg/L	1.96 mg/L of ammonia for the monthly average and 10.1 mg/L of ammonia for daily maximum at pH=7.9 and temperature of 20 °C as per Resolutions 2002-011 and 2005-014.
Temperature	°F	Receiving water shall not be altered by more than 5 °F above the natural temperature.

Constituent	Units	Water Quality Criteria
Turbidity	NTU	Where natural turbidity is between 0 and 50 NTU, increases shall not exceed 20%. Where natural turbidity is greater than 50 NTU increases shall not exceed 10%.
Total suspended solids or settleable materials	mg/L mL/L	Waters shall not contain suspended or settleable material in concentrations that cause nuisance or adversely affect beneficial uses.
BOD ₅ 20 °C	mg/L	Waters shall be free of substances that result in increases in the BOD which adversely affect beneficial uses.
Oil and grease	mg/L	Waters shall not contain oils, greases, waxes or other materials in concentrations that result in a visible film or coating on the surface of the water or on objects in the water, that cause nuisance, or that otherwise adversely affect beneficial uses.
Total residual chlorine	mg/L	Chlorine residual shall not be present in surface water discharges at concentrations that exceed 0.1 mg/L or shall not persist in the receiving waters at any concentration that causes impairment of beneficial uses.
Total dissolved solids	mg/L	Numerical mineral quality objectives for individual surface waters as designated in Table 3-8 of the Basin Plan.
Chloride	mg/L	
Sulfate	mg/L	
Iron	mg/L	
Detergents (as MBAS)	mg/L	
Nitrate + Nitrite –N	mg/L	Waters shall not exceed 10 mg/L nitrogen as nitrate-nitrogen plus nitrite-nitrogen (NO ₃ -N +NO ₂ -N), 45 mg/L as nitrate (NO ₃), 10 mg/L as nitrate-nitrogen (NO ₃ -N), or 1 mg/L as nitrite-nitrogen (NO ₃ -N) or as otherwise designated in Table 3-8.
Nitrate-N	mg/L	
Nitrite-N	mg/L	
Chemical Constituents		Surface waters shall not contain concentrations of chemical constituents in amounts that adversely affect any designated beneficial use. Water designated for use as Domestic or Municipal Supply (MUN) shall not contain concentrations of chemical constituents in excess of the limits specified in the provisions of Title 22 of the California Code of Regulations.
Barium	mg/L	
Fluoride	mg/L	
Manganese	mg/L	
Antimony	µg/L	
Arsenic	µg/L	
Beryllium	µg/L	
Cyanide	µg/L	
Thallium	µg/L	

Constituent	Units	Water Quality Criteria
Perchlorate	µg/L	
Trichloroethylene	µg/L	
Bis(2-ethylhexyl)phthalate	µg/L	
Radioactivity Gross Alpha Gross Beta	pCi/L pCi/L	Radionuclides shall not be present in concentrations that are deleterious to human, plant, animal, or aquatic life or that result in the accumulation of radionuclides in the food web to an extent that presents a hazard to human, plant, animal, or aquatic life.
Combined Radium 226 & Radium 228	pCi/L	
Tritium	pCi/L	
Strontium-90	pCi/L	

3. Determining the Need for WQBELs

In accordance with Section 1.3 of the SIP, the Regional Water Board conducts a reasonable potential analysis (RPA) for each priority pollutant with an applicable criterion or objective to determine if a WQBEL is required in the permit. The Regional Water Board analyzes effluent and receiving water data and identifies the maximum observed effluent concentration (MEC) and maximum background concentration (B) in the receiving water for each constituent. To determine reasonable potential, the MEC and the B are then compared with the applicable water quality objectives (C) outlined in the CTR, NTR, as well as the Basin Plan. For all pollutants that have a reasonable potential to cause or contribute to an excursion above a state water quality standard, numeric WQBELs are required. The RPA considers water quality criteria from the CTR and NTR, and when applicable, water quality objectives specified in the Basin Plan. To conduct the RPA, the Regional Water Board identifies the MEC and maximum background concentration in the receiving water for each constituent, based on data provided by the Discharger.

Section 1.3 of the SIP provides the procedures for determining reasonable potential to exceed applicable water quality criteria and objectives. The SIP specifies three triggers to complete a RPA:

- 1) Trigger 1 – If the MEC ≥ C, a limit is needed.
- 2) Trigger 2 – If the background concentration (B) > C and the pollutant is detected in the effluent, a limit is needed.

- 3) Trigger 3 – If other related information such as CWA 303(d) listing for a pollutant, discharge type, compliance history, etc. indicates that a WQBEL is required.

Sufficient effluent and receiving water data are needed to conduct a complete RPA. If data are not sufficient, the Discharger will be required to gather the appropriate data for the Regional Water Board to conduct the RPA. Upon review of the data, and if the Regional Water Board determines that WQBELs are needed to protect the beneficial uses, the permit will be reopened for appropriate modification.

The RPA was performed for the priority pollutants regulated in the CTR for which data are available. The data set includes information collected from 2005 through 2004 through 1st Quarter of 2010. The results of the RPA are included in the following table. Refer to Attachment J for a summary of the RPA and associated effluent limitation calculations.

Table F-6a. Summary of Reasonable Potential Analysis Outfalls 011, 018, 019

CTR No.	Constituent	Applicable Water Quality Criteria (C)	Max Effluent Conc. (MEC)	Maximum Detected Receiving Water Conc. (B)	RPA Result - Need Limit?	Reason
		µg/L	µg/L	µg/L		
1	Antimony	6 ³	1.3	--	Yes	Limit based on BPJ
2	Arsenic	10 ³	35	--	Yes	MEC>C
3	Beryllium	4 ³	11	--	Yes	MEC>C
4	Cadmium	2 ^{1,2}	6.9	--	Yes – Limit based on TMDL	303(d) listed pollutant
5a	Chromium III	180	0.65	--	No	Analysis used to meet Chromium VI requirement
5b.	Chromium VI	8.1		--	Yes	BPJ
6	Copper	7.1	8.9	--	Yes – Limit based on TMDL ¹	303(d) listed pollutant
7	Lead	2.6	3.1	--	Yes	MEC>C
8	Mercury	0.05	0.32	--	Yes	MEC>C
9	Nickel	35	5	--	Yes	Limit based on BPJ
10	Selenium	4.1	2	--	Yes	Limit based on BPJ
11	Silver	2.0	1	--	Yes	Limit based on BPJ
12	Thallium	2.0 ³	1.9	--	Yes	MEC=C
13	Zinc	54	790	--	Yes	MEC>C,

CTR No.	Constituent	Applicable Water Quality Criteria (C)	Max Effluent Conc. (MEC)	Maximum Detected Receiving Water Conc. (B)	RPA Result - Need Limit?	Reason
		µg/L	µg/L	µg/L		
						303(d) listed pollutant
14	Cyanide	4.3	18	--	Yes	MEC>C
16	TCDD	1.4E-08	2E-06	--	Yes	MEC>C
29	1,1-Dichloroethane	0.5	2.4	--	Yes	MEC>C
30	1,1-Dichloroethylene	3.2	ND	--	Yes	Limit based on BPJ
43	Trichloroethylene	5 ³	ND	--	Yes	Limit based on BPJ
53	Pentachlorophenol	8.2	4	--	Yes	Limit based on BPJ
55	2,4,6-Trichlorophenol	6.5	4.1	--	Yes	Limit based on BPJ
68	Bis(2-ethylhexyl)phthalate	5.9	ND	--	Yes	Limit based on BPJ
82	2,4-Dinitrotoluene	9.1	5.4	--	Yes	Limit based on BPJ
98	N-Nitrosodimethylamine	8.1	3.7	--	Yes	Limit based on BPJ
103	Alpha BHC	0.013	0.015	--	Yes	Limit based on BPJ
	Perchlorate	6 ⁴	5.8	--	Yes	Limit based on BPJ
	Radioactivity Gross Alpha (pCi/L) Gross Beta (pCi/L)	15 ³ 50 ³	17.3 20	-- --	Yes	Limit based on BPJ
	Combined Radium-226 & Radium 228 (pCi/L)	5 ³	17	--	Yes	MEC>C
	Tritium (pCi/L)	20,000 ³	230	--	Yes	Limit based on BPJ
	Strontium-90 (pCi/L)	8 ³	2.8	--	Yes	Limit based on BPJ

- 1 Based on dry weather TMDL limit for LA River
- 2 Based on wet weather TMDL limit for LA River
- 3 Based on Basin Plan
- 4 Based on California MCL

Table F-6b. Summary of Reasonable Potential Analysis Outfalls 003 - 010

CTR No.	Constituent	Applicable Water Quality Criteria (C)	Max Effluent Conc. (MEC)	Maximum Detected Receiving Water Conc. (B)	RPA Result - Need Limit?	Reason
		µg/L	µg/L	µg/L		
1	Antimony	6 ³	35	--	Yes	MEC>C

CTR No.	Constituent	Applicable Water Quality Criteria (C)	Max Effluent Conc. (MEC)	Maximum Detected Receiving Water Conc. (B)	RPA Result - Need Limit?	Reason
		µg/L	µg/L	µg/L		
4	Cadmium	4.0/3 ^{1,2}	9.2		Yes	MEC>C
6	Copper	14	39	--	Yes	MEC>C
7	Lead	5.2	26	--	Yes	MEC>C
8	Mercury	0.1	0.89	--	Yes	MEC>C
9	Nickel	96	15	--	Yes	MEC>C
10	Selenium ⁵	5	8.1	--	Yes	TMDL
12	Thallium	2.0 ³	0.41	--	Yes	BPJ
13	Zinc ⁵	119	4	--	Yes	BPJ
14	Cyanide	8.5	9.6	--	Yes	MEC>C
16	TCDD	2.8E-08	9.1E-04	--	Yes	MEC>C
	Perchlorate	6 ⁴	2.5	--	Yes	BPJ
	Radioactivity					
	Gross Alpha (pCi/L)	15 ³	1.34	--	Yes	BPJ
	Gross Beta (pCi/L)	50 ³	43.8	--	Yes	
	Combined Radium-226 & Radium 228 (pCi/L)	5 ³	1.9	--	Yes	BPJ
	Tritium (pCi/L)	20,000 ³	106	--	Yes	BPJ
	Strontium-90 (pCi/L)	8 ³	11.4	--	Yes	BPJ

- ¹ Based on dry weather TMDL limit for LA River
- ² Based on wet weather TMDL limit for LA River
- ³ Based on Basin Plan
- ⁴ Based on California MCL
- ⁵ Outfall 008 only

4. WQBEL Calculations

- a. If a reasonable potential exists to exceed applicable water quality criteria or objectives, then a WQBEL must be established in accordance with one or more of the three procedures contained in Section 1.4 of the SIP. These procedures include:
 - i. If applicable and available, use of the waste load allocation (WLA) established as part of a total maximum daily load (TMDL).
 - ii. Use of a steady-state model to derive maximum daily effluent limitations (MDELs) and average monthly effluent limitations (AMELs).
 - iii. Where sufficient effluent and receiving water data exist, use of a dynamic model, which has been approved by the Regional Water Board.

- b. Water quality based effluent limits (final) for a number of priority pollutants are based on monitoring results and following the procedure based on the steady-state model, available in Section 1.4 of the SIP.
- c. Since many of the streams in the Region have minimal upstream flows, mixing zones and dilution credits are usually not appropriate. Therefore, in this proposed Order, no dilution credit is being allowed. However, in accordance with the reopener provision in Section VI.C.1.e in the proposed Order, this Order may be reopened upon the submission by the Discharger of adequate information to establish appropriate dilution credits or a mixing zone, as determined by the Regional Water Board.
- d. WQBELs Calculation Example

Using copper as an example, the following demonstrates how WQBELs were established for this Order. The tables in Attachment J summarize the development and calculation of all WQBELs for this Order using the process described below.

Concentration-Based Effluent Limitations

A set of AMEL and MDEL values are calculated separately, one set for the protection of aquatic life and the other for the protection of human health. The AMEL and MDEL limitations for aquatic life and human health are compared, and the most restrictive AMEL and the most restrictive MDEL are selected as the WQBEL.

Calculation of aquatic life AMEL and MDEL:

Step 1: For each constituent requiring an effluent limit, identify the applicable water quality criteria or objective. For each criteria determine the effluent concentration allowance (ECA) using the following steady state equation:

$$\begin{aligned} \text{ECA} &= C + D(C - B) \quad \text{when } C > B, \text{ and} \\ \text{ECA} &= C \quad \quad \quad \text{when } C \leq B, \end{aligned}$$

- Where
- C = The priority pollutant criterion/objective, adjusted if necessary for hardness, pH and translators. In this Order a pH of 7.9 was used for pH-dependent criteria and 100 mg/L as CaCO₃ was the hardness value used for hardness-dependent criteria.
 - D = The dilution credit, and
 - B = The ambient background concentration

As discussed above, for this Order, dilution was not allowed; therefore:

$$\text{ECA} = C$$

For copper, the applicable water quality criteria is given in Table F-5a. After adjustment of hardness value, the total recoverable metals water quality criteria (as shown in Attachment Table R2) are:

$$\begin{aligned} ECA_{acute} &= 14.0 \mu\text{g/L} \\ ECA_{chronic} &= 9.33 \mu\text{g/L} \end{aligned}$$

Step 2: For each ECA based on aquatic life criterion/objective, determine the long-term average discharge condition (LTA) by multiplying the ECA by a factor (multiplier). The multiplier is a statistically based factor that adjusts the ECA to account for effluent variability. The value of the multiplier varies depending on the coefficient of variation (CV) of the data set and whether it is an acute or chronic criterion/objective. Table 1 of the SIP provides pre-calculated values for the multipliers based on the value of the CV. Equations to develop the multipliers in place of using values in the tables are provided in Section 1.4, Step 3 of the SIP and will not be repeated here.

$$LTA_{acute} = ECA_{acute} \times \text{Multiplier}_{acute 99}$$

$$LTA_{chronic} = ECA_{chronic} \times \text{Multiplier}_{chronic 99}$$

The CV for the data set must be determined before the multipliers can be selected and will vary depending on the number of samples and the standard deviation of a data set. If the data set is less than 10 samples, or at least 80% of the samples in the data set are reported as non-detect, the CV shall be set equal to 0.6.

For copper, the following data was used to develop the acute and chronic LTA using equations provided in Section 1.4, Step 3 of the SIP (Table 1 of the SIP also provides this data up to three decimals):

No. of Samples	CV	ECA Multiplier _{acute 99}	ECA Multiplier _{chronic 99}
4	0.581	0.33	0.53

$$LTA_{acute} = 14.0 \mu\text{g/L} \times 0.37 = 4.6 \mu\text{g/L}$$

$$LTA_{chronic} = 9.33 \mu\text{g/L} \times 0.54 = 5.0 \mu\text{g/L}$$

Step 3: Select the most limiting (lowest) of the LTA.

$$LTA = \text{most limiting of } LTA_{acute} \text{ or } LTA_{chronic}$$

For copper, the most limiting LTA was the LTA_{acute}

$$LTA = 4.6 \mu\text{g/L}$$

Step 4: Calculate the WQBELs by multiplying the LTA by a factor (multiplier). WQBELs are expressed as Average Monthly Effluent Limitations (AMEL) and

Maximum Daily Effluent Limitation (MDEL). The multiplier is a statistically based factor that adjusts the LTA for the averaging periods and exceedance frequencies of the criteria/objectives and the effluent limitations. The value of the multiplier varies depending on the probability basis, the coefficient of variation (CV) of the data set, the number of samples (for AMEL) and whether it is a monthly or daily limit. Table 2 of the SIP provides pre-calculated values for the multipliers based on the value of the CV and the number of samples. Equations to develop the multipliers in place of using values in the tables are provided in Section 1.4, Step 5 of the SIP and will not be repeated here.

$$AMEL_{\text{aquatic life}} = LTA \times AMEL_{\text{multiplier 95}}$$

$$MDEL_{\text{aquatic life}} = LTA \times MDEL_{\text{multiplier 99}}$$

AMEL multipliers are based on a 95th percentile occurrence probability, and the MDEL multipliers are based on the 99th percentile occurrence probability. If the number of samples is less than four (4), the default number of samples to be used is four (4).

For copper, the following data was used to develop the AMEL and MDEL for aquatic life using equations provided in Section 1.4, Step 5 of the SIP (Table 2 of the SIP also provides this data up to two decimals):

No. of Samples Per Month	CV	Multiplier _{MDEL 99}	Multiplier _{AMEL 95}
4	0.58	3.0	1.5

$$AMEL_{\text{aquatic life}} = 4.48 \times 1.55 = 7.1 \mu\text{g/L}$$

$$MDEL_{\text{aquatic life}} = 4.48 \times 3.11 = 14.0 \mu\text{g/L}$$

Calculation of human health AMEL and MDEL:

Step 5: For the ECA based on human health, set the AMEL equal to the ECA_{human health}

$$AMEL_{\text{human health}} = ECA_{\text{human health}}$$

However, for copper:

ECA_{human health} = Not Available. The CTR does not contain a numeric copper criterion protective of human health for organisms only; therefore, it was not possible to develop a copper AMEL based on human health criteria.

Step 6: Calculate the MDEL for human health by multiplying the AMEL by the ratio of the Multiplier_{MDEL} to the Multiplier_{AMEL}. Table 2 of the SIP provides pre-calculated ratios to be used in this calculation based on the CV and the number of samples.

$$MDEL_{\text{human health}} = AMEL_{\text{human health}} \times (\text{Multiplier}_{MDEL} / \text{Multiplier}_{AMEL})$$

A copper MDEL_{human health} could not be calculated because a copper AMEL_{human health} was not available. There are no human health criteria for copper; therefore, none of the limitations for copper are based on human health criteria.

Step 7: Select the lower of the AMEL and MDEL based on aquatic life and human health as the water-quality based effluent limit for the Order.

For copper:

AMEL _{aquatic life}	MDEL _{aquatic life}	AMEL _{human health}	MDEL _{human health}
7.1 µg/L	14 µg/L	N/A	N/A

the lowest (most restrictive) effluent limits are based on aquatic toxicity and were incorporated into this Order.

5. WQBELS based on Basin Plan Objectives

The Basin Plan states that the pH of inland surface waters shall not be depressed below 6.5 or raised above 8.5 as a result of waste discharge. Based on the requirements of the Basin Plan an instantaneous minimum limitation of 6.5 and an instantaneous maximum limitation of 8.5 for pH are included in the proposed permit. The Basin Plan provides narrative criteria for temperature for both WARM and COLD water beneficial uses and requirements for the receiving waters. It also references the Thermal Plan. Based on the requirements of the Thermal Plan and a white paper developed by Regional Water Board staff entitled *Temperature and Dissolved Oxygen Impacts on Biota in Tidal Estuaries and Enclosed Bays in the Los Angeles Region*, a maximum effluent temperature limitation of 86 °F is included in the proposed permit. The white paper evaluated the optimum temperatures for steelhead, topsmelt, ghost shrimp, brown rock crab, jackknife clam, and blue mussel.

The Basin Plan includes water quality objectives for TDS, sulfate, chloride, and nitrogen for the Los Angeles River Watershed and the Calleguas Creek Watershed. The objectives listed for these pollutants were included in the Order. The objectives are established to protect designated beneficial uses of the receiving waters. Further, the Basin Plan objectives are applied to the discharge end of pipe, because the receiving water has no dilution capabilities. As indicated previously, the receiving water only flows intermittently.

6. Whole Effluent Toxicity (WET)

Whole effluent toxicity (WET) protects the receiving water quality from the aggregate toxic effect of a mixture of pollutants in the effluent. WET tests measure the degree of response of exposed aquatic test organisms to an effluent. The WET approach allows for protection of the narrative “no toxics in toxic amounts” criterion while implementing numeric criteria for toxicity. There are two types of WET tests: acute and chronic. An acute toxicity test is conducted over a short time period and measures mortality. A chronic toxicity test is conducted over a longer period of time and may measure mortality, reproduction, and growth.

The Basin Plan specifies a narrative objective for toxicity, requiring that all waters be maintained free of toxic substances in concentrations that are lethal to or produce other detrimental responses by aquatic organisms. Detrimental response includes but is not limited to decreased growth rate, decreased reproductive success of resident or indicator species, and/or significant alterations in population, community ecology, or receiving water biota. The existing Order contains acute toxicity limitations and monitoring requirements in accordance with the Basin Plan, in which the acute toxicity objective for discharges dictates that the average survival in undiluted effluent for any three consecutive 96-hour static or continuous flow bioassay tests shall be at least 90%, with no single test having less than 70% survival. The Facility’s effluent has been in compliance with existing acute toxicity limitations. Consistent with Basin Plan requirements, this Order also includes the acute toxicity limitations and monitoring requirements.

In addition to the Basin Plan requirements, section 4 of the SIP states that a chronic toxicity effluent limitation is required in permits for all discharges that will cause, have the reasonable potential to cause, or contribute to chronic toxicity in receiving waters. This Order includes the chronic toxicity and monitoring to demonstrate compliance.

7. Final WQBELs

A summary of final WQBELs proposed in this Order is provided in Table F-7.

Table F-7. Summary of Water Quality-based Effluent Limitations for Outfalls 001, 002, 011, 018, 019

Parameter	Units	Effluent Limitations	
		Average Monthly ¹	Maximum Daily
Antimony	µg/L	--	6
Arsenic	µg/L	--	10
Beryllium	µg/L	--	4
Cadmium	µg/L	2.0	4.0/3.1
Chromium VI	µg/L	8.1	16.3

Parameter	Units	Effluent Limitations	
		Average Monthly ¹	Maximum Daily
Copper	µg/L	7.1	14
Lead, Total Recoverable	µg/L	2.6	5.2
Mercury	µg/L	0.05	0.1
Nickel	µg/L	35	96
Selenium	µg/L	4.1	8.2/5
Silver	µg/L	2	4.1
Thallium	µg/L	--	2
Zinc	µg/L	54	119
Cyanide	µg/L	4.3	8.5
1,1-Dichloroethylene	µg/L	3.2	6.0
1,2-Dichloroethane	µg/L	--	0.5
Trichloroethylene	µg/L	--	5.0
Perchlorate	µg/L	--	6
2,4,6-Trichlorophenol	µg/L	6.5	13
2,4-Dinitrotoluene	µg/L	9.1	18.3
Alpha-BHC	µg/L	0.01	0.03
Bis(2-ethylhexyl)phthalate	µg/L	--	4
N-Nitrosodimethylamine	µg/L	8.1	16.3
Pentachlorophenol	µg/L	8.2	16.5
2,3,7,8-TCDD ³	µg/L	1.4E-08	2.8E-08
Radioactivity			
Gross Alpha	pCi/L	--	15
Gross Beta	pCi/L	--	50
Combined Radium-226 & Radium-228	pCi/L	--	5
Tritium	pCi/L	--	20,000
Strontium-90	pCi/L	--	8
Acute toxicity ²	% survival	--	--

¹ Applicable to discharges from Outfall 019 only.

² The acute toxicity of the effluent shall be such that: (i) the average survival in the undiluted effluent for any three (3) consecutive 96-hour static or continuous bioassay tests shall be at least 90%, and (ii) no single test producing less than 70% survival.

³ The limit for 2,3,7,8-TCDD is evaluated in TCDD equivalents. See full description on Page F-31.

Table F-7a. Summary of Water Quality-based Effluent Limitations for Outfalls 003-010

Parameter	Units	Effluent Limitations	
		Average Monthly	Maximum Daily
Antimony	µg/L	--	6
Cadmium	µg/L	--	4/3.1
Copper	µg/L	--	14
Cyanide	µg/L	--	9.5
Lead, Total Recoverable	µg/L	--	5.2
Mercury	µg/L	--	0.13
Nickel	µg/L	--	100
Selenium (Outfall 008 only)	µg/L	--	5
Thallium	µg/L	--	2
Zinc (Outfall 008 only)	µg/L	--	159
2,3,7,8-TCDD -TEQs	µg/L	--	2.8E-08
Perchlorate	µg/L	--	6
Radioactivity			
Gross Alpha	pCi/L	--	15
Gross Beta	pCi/L		50
Combined Radium-226 & Radium-228	pCi/L	--	5
Tritium	pCi/L	--	20,000
Strontium-90	pCi/L	--	8
Acute toxicity ¹	% survival	--	--

¹ The acute toxicity of the effluent shall be such that: (i) the average survival in the undiluted effluent for any three (3) consecutive 96-hour static or continuous bioassay tests shall be at least 90%, and (ii) no single test producing less than 70% survival.

D. Final Effluent Limitations

Section 402(o) of the CWA and section 122.44(l) require that effluent limitations or conditions in reissued Orders be at least as stringent as those in the existing Orders based on the submitted sampling data. Effluent limitations for constituents included in previous Orders and are considered pollutants of concern at the Facility have been included in this Order.

1. Satisfaction of Anti-Backsliding Requirements

Effluent limitations in this Order are at least as stringent as the effluent limitations in the previous Order. This Order also includes a new effluent limitation for 1,2-

dichloroethane. Data obtained demonstrated reasonable potential for that constituent.

2. Satisfaction of Antidegradation Policy

Section 131.12 requires that the state water quality standards include an anti-degradation policy consistent with the federal policy. The State Water Board established California's antidegradation policy in State Water Board Resolution No. 68-16. Resolution No. 68-16 incorporates the federal antidegradation policy where the federal policy applies under federal law. Resolution No. 68-16 requires that existing water quality be maintained unless degradation is justified based on specific findings. The Regional Water Board's Basin Plan implements, and incorporates by reference, both the State and federal antidegradation policies.

The discharge is not a new discharge and many of the operations which historically contributed contaminants to the discharge have been terminated. Currently, there are only two components to the discharge: treated groundwater effluent and storm water runoff. The treated groundwater effluent, when discharges from the system are initiated, will be monitored for chemicals of concern at the facility and it must meet the effluent limits prior to discharge to tributaries to surface waters onsite. The storm water runoff from the site has historically had elevated concentrations of contaminants associated with historical operations. This permit includes effluent limits developed to protect the beneficial uses of the receiving waters. The effluent limits ensure that the discharge does not adversely impact the beneficial uses or degrade water quality of Bell Creek, Dayton Canyon Creek, or Arroyo Simi. The NPDES permit also included prohibitions to ensure that the discharge does not adversely affect the beneficial uses of the receiving water. The inclusion of the effluent limits and prohibitions in the NPDES permit, ensure that any discharge would not result in the lowering of water quality. The requirements support the conclusion that no degradation will arise as a result of reissuing this permit. The issuance of this permit, therefore, is consistent with the state's antidegradation policy.

3. Stringency of Requirements for Individual Pollutants

This Order contains both technology-based and water quality-based effluent limitations for individual pollutants. Technology based effluent limits are in some cases published in the Federal Register. The combination of the SWPPP and BMPs will serve as the equivalent of technology-based effluent limitations, in the absence of established ELGs, in order to carry out the purposes and intent of the CWA.

The technology-based effluent limitations consist of restrictions on TSS, BOD, oil and grease, and settleable solids. Restrictions on these pollutants are discussed in section IV.B. of the Fact Sheet. This Order's technology-based pollutant restrictions implement the minimum, applicable federal technology-based requirements.

Water quality-based effluent limitations have been scientifically derived to implement water quality objectives that protect beneficial uses. Both the beneficial uses and

the water quality objectives have been approved pursuant to federal law and are the applicable federal water quality standards. All beneficial uses and water quality objectives contained in the Basin Plan were approved under state law and submitted to and approved by USEPA prior to May 30, 2000. Any water quality objectives and beneficial uses submitted to USEPA prior to May 30, 2000, but not approved by USEPA before that date, are nonetheless “applicable water quality standards for purposes of the CWA” pursuant to section 131.21(c)(1). Collectively, this Order’s restrictions on individual pollutants are no more stringent than required to implement the requirements of the CWA.

4. Mass-based Effluent Limitations

Mass-based effluent limitations are established using the following formula:

$$\text{Mass (lbs/day)} = \text{flow rate (mgd)} \times 8.34 \times \text{effluent limitation (mg/L)}$$

where: Mass = mass limitation for a pollutant (lbs/day)
 Effluent limitation = concentration limit for a pollutant (mg/L)
 Flow rate = discharge flow rate (MGD)

Table F-8. Summary of Final Effluent Limitations for Outfalls 011, 018, and 019

Parameter	Units	Effluent Limitations			Basis for Limitation ¹
		Average Monthly ⁴	Maximum Daily	Instantaneous Minimum/Maximum	
<i>Conventional Pollutants</i>					
Biochemical Oxygen Demand (BOD)(5-day @20 Deg. C)	mg/L	20	30	--	E , BPJ
	lbs/day ²	26,700	40,032	--	
Oil and Grease	mg/L	10	15	--	E, BPJ
	lbs/day ²	13,344	20,016	--	
pH	s.u.	--	--	6.5/8.5	BP
Total Suspended Solids (TSS)	mg/L	15	45	--	BP, BPJ, E
	lbs/day ²	20,016	60,048	--	
<i>Priority Pollutants</i>					
Antimony, Total Recoverable	µg/L	--	6.0	--	BP, BPJ
	lbs/day ²	--	8.0	--	
Arsenic, Total Recoverable	µg/L	--	10	--	USEPA MCL
	lbs/day ²	--	67	--	
Beryllium, Total Recoverable	µg/L	--	4.0	--	BP-Title 22
	lbs/day ²	--	5.3	--	

Parameter	Units	Effluent Limitations			
		Average Monthly ⁴	Maximum Daily	Instantaneous Minimum/Maximum	Basis for Limitation ¹
Cadmium, Total Recoverable	µg/L	2.0	4.0/3.1	--	CTR/LA River Metals TMDL
	lbs/day ²	2.7	5.3/4.1	--	
Chromium VI, Total Recoverable	µg/L	8.1	16	--	CTR
	lbs/day ²	11	22	--	
Copper, Total Recoverable	µg/L	7.1	14	--	CTR
	lbs/day ²	10	19	--	
Lead, Total Recoverable	µg/L	2.6	5.2	--	CTR
	lbs/day ²	3.5	6.9	--	
Mercury, Total Recoverable	µg/L	0.05	0.10	--	CTR
	lbs/day ²	0.07	0.13	--	
Nickel, Total Recoverable	µg/L	35	96	--	CTR
	lbs/day ²	47	128	--	
Selenium, Total Recoverable	µg/L	4.1	8.2/5	--	CTR/LA River Metals TMDL
	lbs/day ²	5.5	11/6.7	--	
Silver, Total Recoverable	µg/L	2.0	4.1	--	CTR
	lbs/day ²	2.7	5.5	--	
Thallium, Total Recoverable	µg/L	--	2.0	--	BP
	lbs/day ²	--	2.7	--	
Zinc, Total Recoverable	µg/L	54	119	--	CTR
	lbs/day ²	72	159	--	
Cyanide	µg/L	4.3	8.5	--	BPJ
	lbs/day ²	5.7	11	--	
1,2-dichloroethane (not applicable at Outfall 019)	µg/L	--	0.5	--	BP
	lbs/day ²	--	3.4	--	
1,1-Dichloroethylene	µg/L	3.2	6.0	--	CTR/BPJ-Title 22
	lbs/day ²	4.3	8.0	--	
Trichloroethylene	µg/L	--	5.0	--	BPJ
	lbs/day ²	--	6.7	--	
TCDD (TEQ)	µg/L	1.4E-08	2.8E-08	--	CTR
	lbs/day ²	1.9E-08	3.7E-08	--	

Parameter	Units	Effluent Limitations			Basis for Limitation ¹
		Average Monthly ⁴	Maximum Daily	Instantaneous Minimum/Maximum	
2,4,6-Trichloephenol	µg/L	6.5	13	--	CTR
	lbs/day ²	8.7	17	--	
2,4-Dinitrotoluene	µg/L	9.1	18	--	CTR
	lbs/day ²	12	24	--	
Alpha BHC	µg/L	0.01	0.03	--	CTR
	lbs/day ²	0.013	0.04	--	
N-Nitrosodimethylamine	µg/L	8.1	16	--	CTR
	lbs/day ²	11	22	--	
Pentachlorophenol	µg/L	8.2	16	--	CTR
	lbs/day ²	11	22	--	
Bis(2-ethylhexyl) phthalate	µg/L	--	4.0	--	BP, BPJ
	lbs/day	--	5.3	--	
<i>Non-Conventional Pollutants</i>					
Chloride	mg/L	--	150	--	BP
	lbs/day	--	200,160	--	
Acute toxicity	% survival	--	³		BP
Chronic toxicity	TUc		1	--	BP
Chlorine, Total Residual	mg/L	--	0.1	--	E, BP
	lbs/day	--	133	--	
Ammonia – N	mg/L	1.96	10.1	--	TMDL
	lbs/day ²	2,615	13,500	--	
Nitrate - N	mg/L	--	8	--	TMDL
	lbs/day ²	--	10,700	--	
Nitrite - N	mg/L	--	1	--	TMDL
	lbs/day ²	--	1,334	--	
Nitrate +Nitrite - N	mg/L	--	8	--	BP, TMDL
	lbs/day ²	--	10,700	--	
Settleable Solids	ml/L	0.1	0.3	--	E, BPJ
Sulfate	mg/L	--	300	--	BP
	lbs/day ²	--	400,320	--	
Barium	mg/L	--	1.0	--	BPJ
	lbs/day ²	--	1,330	--	
Fluoride	mg/L	--	1.6	--	BP, BPJ
	lbs/day ²	--	2,135	--	

Parameter	Units	Effluent Limitations			Basis for Limitation ¹
		Average Monthly ⁴	Maximum Daily	Instantaneous Minimum/Maximum	
Iron	mg/L	--	0.3	--	BPJ
	lbs/day ²	--	400	--	
Detergents (as MBAS)	mg/L	--	0.5	--	BP, BPJ
	lbs/day ²	--	667	--	
Temperature	°F	--	--	86	BP, TP
Total Dissolved Solids	mg/L	--	950	--	BP
	lbs/day ²	--	1,270,000	--	
Perchlorate	µg/L	--	6.0	--	BPJ
	lbs/day ²	--	8.0	--	
Manganese	µg/L	--	50	--	BPJ
	lbs/day ²	--	67	--	
Radioactivity Gross Alpha	pCi/L	--	15	--	BPJ, BP
Gross Beta	pCi/L	--	50	--	BPJ, BP
Combined Radium -226 & Radium-228	pCi/L	--	5.0	--	BPJ, BP
Tritium	pCi/L	--	20,000	--	BPJ, BP
Strontium-90	pCi/L	--	8.0	--	BPJ, BP

¹ E = Existing Order; BP = Basin Plan; CTR = California Toxics Rule; TP = Thermal Plan; TMDL = Total Maximum Daily Load; LA = Los Angeles; BPJ = Best Professional Judgment

² Mass-based effluent limitations are based on a maximum discharge flow rate of 160 MGD.

³ The acute toxicity of the effluent shall be such that: (i) the average survival in the undiluted effluent for any three (3) consecutive 96-hour static or continuous bioassay tests shall be at least 90%, and (ii) no single test producing less than 70% survival.

⁴ The average monthly effluent limitations are applicable to Outfall 019.

Table F-8a. Summary of Final Effluent Limitations for Outfalls 003-010

Parameter	Units	Effluent Limitations		
		Maximum Daily	Instantaneous Minimum/Maximum	Basis for Limitation
<i>Conventional Pollutants</i>				
Oil and Grease	mg/L	15	--	E, BPJ
	lbs/day ²	2,227	--	
pH	s.u.	--	6.5/8.5	BP
<i>Priority Pollutants</i>				
Antimony, Total Recoverable	µg/L	6.0	--	BP, BPJ
	lbs/day ²	0.89	--	

Parameter	Units	Effluent Limitations		
		Maximum Daily	Instantaneous Minimum/Maximum	Basis for Limitation
Cadmium, Total Recoverable	µg/L	4.0 ⁵ /3.1 ⁴	--	CTR/LA River Metals TMDL
	lbs/day ²	0.59 ⁵ /0.46 ⁴	--	
Copper, Total Recoverable	µg/L	14	--	CTR
	lbs/day ²	2.1	--	
Cyanide, Total Recoverable	µg/L	9.5	--	CTR
	lbs/day ²	1.4	--	
Lead, Total Recoverable	µg/L	5.2	--	CTR
	lbs/day ²	0.77	--	
Mercury, Total Recoverable	µg/L	0.13	--	CC Metals TMDL/CTR
	lbs/day ²	0.02	--	
Nickel, Total Recoverable	µg/L	100	--	CC Metals TMDL
	lbs/day ²	14.9	--	
Selenium, Total Recoverable	µg/L	5	--	LA River Metals TMDL /BPJ
	lbs/day ²	0.7	--	
Thallium, Total Recoverable	µg/L	2.0	--	BP
	lbs/day ²	0.3	--	
Zinc, Total Recoverable	µg/L	159	--	LA River Metals TMDL/CTR
	lbs/day ²	24	--	
TCDD	µg/L	2.8E-08	--	E, CTR, BPJ
	lbs/day ²	4.2E-09	--	
<i>Non-Conventional Pollutants</i>				
Acute toxicity	% survival	³		BP
Chronic toxicity	TUc	1	--	BP
Chloride	mg/L	150	--	BP
	lbs/day	22,268	--	
Boron	mg/L	1.0	--	E, BP
	lbs/day	148	--	
Ammonia – N ⁴	mg/L	10.1	--	LA River Nutrient TMDL, E
	lbs/day ²	15,000	--	
Nitrate – N ⁴	mg/L	8	--	LA River Nutrient TMDL, E
	lbs/day ²	1,190	--	

Parameter	Units	Effluent Limitations		
		Maximum Daily	Instantaneous Minimum/Maximum	Basis for Limitation
Nitrite – N ⁴	mg/L	1	--	LA River Nutrient TMDL, E
	lbs/day ²	148	--	
Nitrate +Nitrite - N	mg/L	8 ⁴	--	E, BP
	lbs/day ²	1,188	--	
Nitrate +Nitrite - N	mg/L	10 ⁵	--	E, BP
	lbs/day ²	1,485	--	
Sulfate	mg/L	300 ⁴	--	E, BP
	lbs/day ²	44,536	--	
Sulfate	mg/L	250 ⁵	--	E, BP
	lbs/day ²	37,113	--	
Fluoride	mg/L	1.6	--	BP, BPJ
	lbs/day ²	238	--	
Perchlorate	µg/L	6.0	--	E, BPJ, MCL
	lbs/day ²	0.89	--	
Temperature	°F	--	86	BP, TP
Total Dissolved Solids	mg/L	850 ⁵	--	E, BP
	lbs/day	126,184	--	
Total Dissolved Solids	mg/L	950 ⁴	--	E, BP
	lbs/day	141,029	--	
Radioactivity Gross Alpha	pCi/L	15	--	BP, BPJ, E
Gross Beta	pCi/L	50	--	
Combined Radium -226 & Radium-228	pCi/L	5.0	--	BP, BPJ, E
Tritium	pCi/L	20,000	--	BP, BPJ, E
Strontium-90	pCi/L	8.0	--	BP, BPJ, E

¹ E = Existing Order; BP = Basin Plan; CTR = California Toxics Rule; TP = Thermal Plan; TMDL = Total Maximum Daily Load; LA = Los Angeles; BPJ = Best Professional Judgment, CC= Calleguas Creek

² . The flow used to calculate the mass for Outfalls 003 through 010 is 17.89 mgd.

³ The acute toxicity of the effluent shall be such that: (i) the average survival in the undiluted effluent for any three (3) consecutive 96-hour static or continuous bioassay tests shall be at least 90%, and (ii) no single test producing less than 70% survival.

⁴ Limitations apply to Outfall 008 only.

⁵ The limit applies to Outfalls 003 through 007, 009, and 010 which flow to Calleguas Creek. It is not applicable at Outfall 008 which flows to Bell Creek, a tributary to LA River

Table F-8b - Summary of Benchmarks* – Outfalls 012-014

Parameter	Units	Benchmark Limitations		
		Maximum Daily	Instantaneous Minimum/Maximum	Basis for Benchmark ¹
<i>Conventional Pollutants</i>				
Oil and Grease	mg/L	15	--	E, BPJ
	lbs/day ²	0.5	--	
pH	s.u.	--	6.5/8.5	E, BPJ
<i>Priority Pollutants</i>				
Cadmium, Total Recoverable	µg/L	3.1 ⁴	--	LA River Metals TMDL, E
	lbs/day ²	0.0001	--	
Copper, Total Recoverable	µg/L	14	--	CTR, E
	lbs/day ²	0.0004	--	
Lead, Total Recoverable	µg/L	5.2	--	E, CTR
	lbs/day ²	0.0002	--	
Mercury, Total Recoverable	µg/L	0.10	--	E, CTR
	lbs/day ²	0.000003	--	
Selenium, Total Recoverable	µg/L	5 ⁵	--	LA River Metals TMDL, E
	lbs/day ²	0.0002	--	
Zinc, Total Recoverable	µg/L	159	--	LA River Metals TMDL, E
	lbs/day ²	0.005	--	
Naphthalene	µg/L	21	--	E, BPJ
	lbs/day ²	0.0007	--	
TCDD	µg/L	2.8E-08	--	BPJ
	lbs/day ²	9.3E-12	--	
<i>Non-Conventional Pollutants</i>				
Acute toxicity	% survival	³		BP, E
Chloride	mg/L	150	--	BP, E
	lbs/day	5.0	--	
Boron	mg/L	1.0	--	BP, E
	lbs/day	0.03	--	
Total petroleum	µg/L	100	--	E, BPJ

Parameter	Units	Benchmark Limitations		
		Maximum Daily	Instantaneous Minimum/Maximum	Basis for Benchmark ¹
hydrocarbons	lbs/day ²	0.003	--	
Ethylene dibromide	µg/L	50	--	E, BPJ
	lbs/day ²	0.002	--	
Tertiary butyl alcohol	µg/L	12	--	E, BPJ
	lbs/day ²	0.0004	--	
Ammonia – N	mg/L	10.1 ⁴	--	LA River Nitrogen TMDL, E
	lbs/day ²	0.34 ⁴	--	
Nitrate – N	mg/L	8	--	LA River Nitrogen TMDL, E
	lbs/day ²	0.3	--	
Nitrite - N	mg/L	1	--	LA River Nitrogen TMDL, E
	lbs/day ²	0.03	--	
Nitrate +Nitrite - N	mg/L	8	--	LA River Nitrogen TMDL, E
	lbs/day ²	0.3	--	
Sulfate	mg/L	300 ²	--	E, BP
	lbs/day ²	10	--	
Fluoride	mg/L	1.6	--	E, BP
	lbs/day ²	0.5	--	
1,4-Dioxane	µg/L	3	--	E, BPJ
	lbs/day ²	0.0001	--	
Perchlorate	µg/L	6.0	--	E, BPJ
	lbs/day ²	0.0002	--	
Temperature	°F	--	86	E, BP, TP
Total suspended solids	mg/L	45	--	E, BPJ
	lbs/day ²	1.5	--	
Total Dissolved Solids	mg/L	950	--	E, BPJ
	lbs/day	31.7	--	

A “benchmark” is a water quality based effluent limit or a performance based limit that is used to evaluate the performance of best management practices (BMPs) with regard to the removal of contaminants present in the discharge. In this permit, the benchmarks are established based on water quality based effluent limitations. Exceedance of a benchmark triggers an evaluation of the BMPs implemented at the site. The evaluation may determine that the BMPs require augmentation, upgrading, or replacement. If so, the Discharger must develop a plan to implement the required upgrades and report to the Regional Water Board staff within 60 days of the reported exceedance. The Discharger will continue monitoring as directed in the Monitoring and Reporting Program.

¹ E = Existing Order; BP = Basin Plan; CTR = California Toxics Rule; TP = Thermal Plan; TMDL = Total Maximum Daily Load; LA = Los Angeles; BPJ = Best Professional Judgment

² The flow used to calculate the mass for Outfalls 012 through 014 is 0.004 mgd.

- ³ The acute toxicity of the effluent shall be such that: (i) the average survival in the undiluted effluent for any three (3) consecutive 96-hour static or continuous bioassay tests shall be at least 90%, and (ii) no single test producing less than 70% survival.
- ⁴ Effluent limit applies only during wet weather discharges.
- ⁵ Applicable during dry weather discharges only.

5. Receiving Water Limitations

The discharge shall not cause the concentration of constituents in Arroyo Simi, a tributary of Calleguas Creek, in excess of the following limits.

Table F-9. Summary of Receiving Water Limitations for Arroyo Simi

Parameter	Units	Basis for Limitation ¹		
		Average Monthly	Maximum Daily	Basis for Limitation
Chlorpyrifos	µg/L	--	0.02	Toxicity TMDL
Diazinon	µg/L	--	0.16	Toxicity TMDL
Chlordane	µg/L	--	0.001	OC Pest & PCBs TMDL
4,4-DDD	µg/L	--	0.0014	OC Pest & PCBs TMDL
4,4-DDE	µg/L	--	0.001	OC Pest & PCBs TMDL
4,4-DDT	µg/L	--	0.001	OC Pest & PCBs TMDL
Dieldrin	µg/L	--	0.0002	OC Pest & PCBs TMDL
PCBs	µg/L	--	0.0003	OC Pest & PCBs TMDL
Toxaphene	µg/L	--	0.0003	OC Pest & PCBs TMDL

6. Final Receiving Water Sediment Effluent Limitations for Arroyo Simi

Final ambient WLAs for pollutants in sediment for storm water dischargers were established in the Calleguas Creek OC Pesticides & PCBs TMDL. In-stream annual averages at the base of each subwatershed where the discharges are located are developed. These in-stream annual averages are compared to the final WLAs.

The final WLAs must be achieved and become sediment limits after the sampling indicates that the Discharger is able to comply with the final WLAs or at the end of the 20-year compliance schedule specified in the TMDL (March 24, 2026), which ever occurs first.

Table F-10. Summary of Final Receiving Water Sediment Limitations for Arroyo Simi

Parameter	Units	Basis for Limitation ¹		
		Average Monthly	Maximum Daily	Basis for Limitation
Chlordane	µg/g	--	0.0033	OC Pest & PCBs TMDL
4,4-DDD	µg/g	--	0.002	OC Pest & PCBs TMDL

Parameter	Units	Basis for Limitation ¹		
		Average Monthly	Maximum Daily	Basis for Limitation
4,4-DDE	µg/g	--	0.0014	OC Pest & PCBs TMDL
4,4-DDT	µg/g	--	0.0003	OC Pest & PCBs TMDL
Dieldrin	µg/g	--	0.0002	OC Pest & PCBs TMDL
PCBs	µg/g	--	0.12	OC Pest & PCBs TMDL
Toxaphene	µg/g	--	0.0006	OC Pest & PCBs TMDL

7. Interim Ambient WLAs for Pollutants in Sediment for Storm Water Discharges to Arroyo Simi

The OC Pesticides & PCBs TMDL includes interim WLAs for contaminants in sediment. The interim limits are effective from the effective date of this permit through June 26, 2014. Sediment samples after that date must comply with final receiving water sediment daily maximum effluent limitations included in Finding 6 above.

Table F-11. Summary of Interim Ambient Receiving Water Sediment Limitations for Arroyo Simi

Parameter	Units	Basis for Limitation ¹		
		Average Monthly	Maximum Daily	Basis for Limitation
Chlordane	µg/g	--	0.0033	OC Pest & PCBs TMDL
4,4-DDD	µg/g	--	0.014	OC Pest & PCBs TMDL
4,4-DDE	µg/g	--	0.17	OC Pest & PCBs TMDL
4,4-DDT	µg/g	--	0.0025	OC Pest & PCBs TMDL
Dieldrin	µg/g	--	0.0011	OC Pest & PCBs TMDL
PCBs	µg/g	--	25.7	OC Pest & PCBs TMDL
Toxaphene	µg/g	--	0.0006	OC Pest & PCBs TMDL

E. Land Discharge Specifications

Not applicable

F. Reclamation Specifications

Not applicable

V. RATIONALE FOR RECEIVING WATER LIMITATIONS

A. Surface Water

The Basin Plan contains numeric and narrative water quality objectives applicable to all surface waters within the Los Angeles Region. Water quality objectives include an objective to maintain the high quality waters pursuant to federal regulations (section 131.12) and State Water Board Resolution No. 68-16. Receiving water limitations in

this Order are included to ensure protection of beneficial uses of the receiving water and are based on the water quality objectives contained in the Basin Plan.

B. Groundwater

Not applicable

VI. RATIONALE FOR MONITORING AND REPORTING REQUIREMENTS

Section 122.48 requires that all NPDES permits specify requirements for recording and reporting monitoring results. Water Code sections 13267 and 13383 authorizes the Regional Water Board to require technical and monitoring reports. The Monitoring and Reporting Program (MRP), Attachment E of this Order, establishes monitoring and reporting requirements to implement federal and state requirements. The following provides the rationale for the monitoring and reporting requirements contained in the MRP for this facility.

A. Influent Monitoring

Not applicable

B. Effluent Monitoring

Monitoring for those pollutants expected to be present in the effluent will be required as stipulated in the MRP. The data will be used to assess the impact of the discharge to the beneficial uses of the receiving waters.

C. Storm Water Monitoring

Storm water runoff discharges from the SSFL are subject to requirements stipulated in the NPDES permit and the Discharger is required to comply with all applicable provisions of the Storm Water Pollution Prevention Plan (SWPPP). This permit includes requirements to develop, implement, and when appropriate update the SWPPP along with the BMPs with the goal of preventing all pollutants from moving into receiving waters.

D. Whole Effluent Toxicity Testing Requirements

Whole effluent toxicity (WET) protects the receiving water quality from the aggregate toxic effect of a mixture of pollutants in the effluent. An acute toxicity test is conducted over a short time period and measures mortality. A chronic toxicity test is conducted over a longer period of time and may measure mortality, reproduction, and growth. This Order includes limitations for acute toxicity, and therefore, monitoring requirements are included in the MRP to determine compliance with the effluent limitations.

Section 4 of the SIP states that a chronic toxicity effluent limitation is required in permits for all discharges that will cause, have the reasonable potential to cause, or contribute to chronic toxicity in receiving waters. This permit includes a chronic toxicity trigger and requirements to monitor at all of the outfalls.

E. Receiving Water Monitoring

1. Surface Water

The Regional Water Board is requiring that the Discharger conduct receiving water monitoring of the CTR priority pollutants at Monitoring Locations RSW-001 and RSW-002. RSW-002 is located in Frontier Park approximately 50 feet upstream from the discharge point of the unnamed tributary into Arroyo Simi. The discharge from Outfalls 011 and 018 which subsequently exists Outfalls 001 and 002 respectively form the headwaters of Bell Creek. The Discharger may use data collected from these outfalls as receiving water data for Bell Creek. Thus data for RSW-001 may be collected at EFF-001, EFF-002, EFF-011, or EFF-018. Priority pollutant monitoring is required for both the Arroyo Simi and Bell Creek once during the five year permit term.

The Calleguas Creek Toxicity TMDL and the Calleguas Creek OC Pesticides & PCBs TMDL include receiving water concentrations that are to be accomplished utilizing BMPs. This Order includes requirements to monitor the receiving water for the specified constituents.

2. Groundwater

Not applicable

F. Sediment Monitoring and Reporting

The OC Pesticides & PCBs TMDL includes sediment contaminant concentrations for tributaries of Calleguas Creek as well. This permit includes monitoring requirements to determine compliance with the stipulated effluent limits.

G. Bioassessment Monitoring

The goals of the bioassessment monitoring for the Arroyo Simi and Los Angeles River are to:

- Determine compliance with receiving water limits;
- Monitor trends in surface water quality;
- Ensure protection of beneficial uses;
- Provide data for modeling contaminants of concern
- Characterize water quality including seasonal variation of surface waters within the watershed;
- Assess the health of the biological community; and
- Determine mixing dynamics of effluent and receiving waters in the estuary.

A requirement for bioassessment monitoring is included in this Order.

VII. RATIONALE FOR PROVISIONS

A. Standard Provisions

Standard Provisions, which apply to all NPDES permits in accordance with section 122.41, and additional conditions applicable to specified categories of permits in accordance with section 122.42, are provided in Attachment D. The Discharger must comply with all standard provisions and with those additional conditions that are applicable under section 122.42.

Section 122.41(a)(1) and (b) through (n) establish conditions that apply to all State-issued NPDES permits. These conditions must be incorporated into the permits either expressly or by reference. If incorporated by reference, a specific citation to the regulations must be included in the Order. Section 123.25(a)(12) allows the state to omit or modify conditions to impose more stringent requirements. In accordance with section 123.25, this Order omits federal conditions that address enforcement authority specified in sections 122.41(j)(5) and (k)(2) because the enforcement authority under the Water Code is more stringent. In lieu of these conditions, this Order incorporates by reference Water Code section 13387(e).

B. Special Provisions

1. Reopener Provisions

These provisions are based on section 123 and the previous Order. The Regional Water Board may reopen the permit to modify permit conditions and requirements. Causes for modifications include the promulgation of new federal regulations, modification in toxicity requirements, or adoption of new regulations by the State Water Board or Regional Water Board, including revisions to the Basin Plan.

2. Special Studies and Additional Monitoring Requirements

Initial Investigation Toxicity Reduction Evaluation Workplan. This provision is based on section 4 of the SIP, Toxicity Control Provisions, which establishes minimum toxicity control requirements for implementing the narrative toxicity objective for aquatic life protection established in the basin plans of the State of California.

3. Best Management Practices and Pollution Prevention

This provision is based on section 122.44(k) and includes the requirement to develop a SWPPP and BMPs.

- a. Storm Water Pollution Prevention Plan (SWPPP). The Discharger is required to update and continue to implement a SWPPP in accordance with Attachment G. The SWPPP will outline site-specific management processes for minimizing storm water runoff contamination and for preventing contaminated storm water runoff from being discharged directly into the receiving water.
- b. Spill Contingency Plan (SCP). Since spill or overflow may occur in the facility, this Order requires the Discharger to prepare a SCP for the Facility. The

Discharger shall review and update, if necessary, the SCP after each incident and make it available for the facility personnel at all times.

4. Construction, Operation, and Maintenance Specifications

Not applicable

5. Special Provisions for Municipal Facilities (POTWs Only)

Not applicable

6. Other Special Provisions

Not applicable

VIII. PUBLIC PARTICIPATION

The California Regional Water Quality Control Board, Los Angeles Region (Regional Water Board) is considering the issuance of waste discharge requirements (WDRs) that will serve as a National Pollutant Discharge Elimination System (NPDES) permit for the Lincoln Avenue Water Company. As a step in the WDR adoption process, the Regional Water Board staff has developed tentative WDRs. The Regional Water Board encourages public participation in the WDR adoption process.

A. Notification of Interested Parties

The Regional Water Board has notified the Discharger and interested agencies and persons of its intent to prescribe waste discharge requirements for the discharge and has provided them with an opportunity to submit their written comments and recommendations.

B. Written Comments

The staff determinations are tentative. Interested persons are invited to submit written comments concerning these tentative WDRs. Comments must be submitted either in person or by mail to the Executive Office at the Regional Water Board at the address above on the cover page of this Order.

To be fully responded to by staff and considered by the Regional Water Board, written comments must be received at the Regional Water Board offices by 5:00 p.m. on May 10, 2010.

C. Public Hearing

The Regional Water Board will hold a public hearing on the tentative WDRs during its regular Board meeting on the following date and time and at the following location:

Date: June 3, 2010

Time: 9:00 A.M.

Location: Metropolitan Water District of Southern California, Board Room 700 North Alameda Street, Los Angeles, California.

Interested persons are invited to attend. At the public hearing, the Regional Water Board will hear testimony, if any, pertinent to the discharge, WDRs, and permit. Oral testimony will be heard; however, for accuracy of the record, important testimony should be in writing.

Please be aware that dates and venues may change. Our Web address is <http://www.waterboards.ca.gov/losangeles> where you can access the current agenda for changes in dates and locations.

D. Nature of Hearing

This will be a formal adjudicative hearing pursuant to section 648 et seq. of title 23 of the California Code of Regulations. Chapter 5 of the California Administrative Procedure Act (commencing with section 11500 of the Government Code) will not apply to this proceeding.

Ex Parte Communications Prohibited: As a quasi-adjudicative proceeding, no board member may discuss the subject of this hearing with any person, except during the public hearing itself. Any communications to the Regional Water Board must be directed to staff.

E. Parties to the Hearing

The following are the parties to this proceeding:

1. The applicant/permittee

Any other persons requesting party status must submit a written or electronic request to staff not later than 20 business days before the hearing. All parties will be notified if other persons are so designated.

F. Public Comments and Submittal of Evidence

Persons wishing to comment upon or object to the tentative waste discharge requirements, or submit evidence for the Board to consider, are invited to submit them in writing to the above address. To be evaluated and responded to by staff, included in the Board's agenda folder, and fully considered by the Board, written comments must be received no later than close of business May 12, 2010. Comments or evidence received after that date will be submitted, ex agenda, to the Board for consideration, but only included in administrative record with express approval of the Chair during the hearing. Additionally, if the Board receives only supportive comments, the permit may be placed on the Board's consent calendar, and approved without an oral testimony.

G. Hearing Procedure

The meeting, in which the hearing will be a part of, will start at 9:00 a.m. Interested persons are invited to attend. Staff will present the matter under consideration, after which oral statements from parties or interested persons will be heard. For accuracy of the record, all important testimony should be in writing. The Board will include in the administrative record written transcriptions of oral testimony that is actually presented at the hearing. Oral testimony may be limited to 3 minutes maximum or less for each

speaker, depending on the number of persons wishing to be heard. Parties or persons with similar concerns or opinions are encouraged to choose one representative to speak. At the conclusion of testimony, the Board will deliberate in open or close session, and render a decision.

Parties or persons with special procedural requests should contact staff. Any procedure not specified in this hearing notice will be waived pursuant to section 648(d) of title 23 of the California Code of Regulations. Objections to any procedure to be used during this hearing must be submitted in writing not later than close of 15 business days prior to the date of the hearing. Procedural objections will not be entertained at the hearing.

H. Waste Discharge Requirements Petitions

Any aggrieved person may petition the State Water Resources Control Board to review the decision of the Regional Water Board regarding the final WDRs. The petition must be submitted within 30 days of the Regional Water Board's action to the following address:

State Water Resources Control Board
Office of Chief Counsel
P.O. Box 100, 1001 I Street
Sacramento, CA 95812-0100

I. Information and Copying

The Report of Waste Discharge (RWD), related documents, tentative effluent limitations and special provisions, comments received, and other information are on file and may be inspected at the address above at any time between 8:30 a.m. and 4:45 p.m., Monday through Friday. Copying of documents may be arranged through the Regional Water Board by calling (213) 576 – 6600.

J. Register of Interested Persons

Any person interested in being placed on the mailing list for information regarding the WDRs and NPDES permit should contact the Regional Water Board, reference this facility, and provide a name, address, and phone number.

K. Additional Information

Requests for additional information or questions regarding this order should be directed to Mazhar Ali at (213) 576-6652.

ATTACHMENT G – STORM WATER POLLUTION PREVENTION PLAN REQUIREMENTS

I. Implementation Schedule

A storm water pollution prevention plan (SWPPP) shall be developed and submitted to the Regional Water Board within 90 days following the adoption of this Order. The SWPPP shall be implemented for each facility covered by this Permit within 10 days of approval from the Regional Water Board, or 6-months from the date of the submittal of the SWPPP to the Regional Water Board (whichever comes first).

II. Objectives

The SWPPP has two major objectives: (a) to identify and evaluate sources of pollutants associated with industrial activities that may affect the quality of storm water discharges and authorized non-storm water discharges from the facility; and (b) to identify and implement site-specific best management practices (BMPs) to reduce or prevent pollutants associated with industrial activities in storm water discharges and authorized non-storm water discharges. BMPs may include a variety of pollution prevention measures or other low-cost and pollution control measures. They are generally categorized as non-structural BMPs (activity schedules, prohibitions of practices, maintenance procedures, and other low-cost measures) and as structural BMPs (treatment measures, run-off controls, overhead coverage.) To achieve these objectives, facility operators should consider the five phase process for SWPPP development and implementation as shown in Table A.

The SWPPP requirements are designed to be sufficiently flexible to meet the needs of various facilities. SWPPP requirements that are not applicable to a facility should not be included in the SWPPP.

A facility's SWPPP is a written document that shall contain a compliance activity schedule, a description of industrial activities and pollutant sources, descriptions of BMPs, drawings, maps, and relevant copies or references of parts of other plans. The SWPPP shall be revised whenever appropriate and shall be readily available for review by facility employees or Regional Water Board inspectors.

III. Planning and Organization

A. Pollution Prevention Team

The SWPPP shall identify a specific individual or individuals and their positions within the facility organization as members of a storm water pollution prevention team responsible for developing the SWPPP, assisting the facility manager in SWPPP implementation and revision, and conducting all monitoring program activities required in Attachment E of this Permit. The SWPPP shall clearly identify the Permit related responsibilities, duties, and activities of each team member. For small facilities, storm water pollution prevention teams may consist of one individual where appropriate.

B. Review Other Requirements and Existing Facility Plans

The SWPPP may incorporate or reference the appropriate elements of other regulatory requirements. Facility operators should review all local, State, and Federal requirements that impact, complement, or are consistent with the requirements of this General Permit. Facility operators should identify any existing facility plans that contain storm water pollutant control measures or relate to the requirements of this Permit. As examples, facility operators whose facilities are subject to Federal Spill Prevention Control and Countermeasures' requirements should already have instituted a plan to control spills of certain hazardous materials. Similarly, facility operators whose facilities are subject to air quality related permits and regulations may already have evaluated industrial activities that generate dust or particulates.

IV. Site Map

The SWPPP shall include a site map. The site map shall be provided on an 8-½ x 11 inch or larger sheet and include notes, legends, and other data as appropriate to ensure that the site map is clear and understandable. If necessary, facility operators may provide the required information on multiple site maps.

TABLE A FIVE PHASES FOR DEVELOPING AND IMPLEMENTING INDUSTRIAL STORM WATER POLLUTION PREVENTION PLANS

PLANNING AND ORGANIZATION

Form Pollution Prevention Team
Review other plans

ASSESSMENT PHASE

Develop a site map
Identify potential pollutant sources
Inventory of materials and chemicals
List significant spills and leaks
Identify non-storm water discharges
Assess pollutant risks

BEST MANAGEMENT PRACTICES IDENTIFICATION PHASE

Non-structural BMPs
Structural BMPs
Select activity and site-specific BMPs

<p>IMPLEMENTATION PHASE</p> <p>Train employees Implement BMPs Conduct recordkeeping and reporting</p>
--

<p>EVALUATION / MONITORING</p> <p>Conduct annual site evaluation Review monitoring information Evaluate BMPs Review and revise SWPPP</p>

The following information shall be included on the site map:

- A.** The facility boundaries; the outline of all storm water drainage areas within the facility boundaries; portions of the drainage area impacted by run-on from surrounding areas; and direction of flow of each drainage area, on-site surface water bodies, and areas of soil erosion. The map shall also identify nearby water bodies (such as rivers, lakes, and ponds) and municipal storm drain inlets where the facility's storm water discharges and authorized non-storm water discharges may be received.
- B.** The location of the storm water collection and conveyance system, associated points of discharge, and direction of flow. Include any structural control measures that affect storm water discharges, authorized non-storm water discharges, and run-on. Examples of structural control measures are catch basins, berms, detention ponds, secondary containment, oil/water separators, diversion barriers, etc.
- C.** An outline of all impervious areas of the facility, including paved areas, buildings, covered storage areas, or other roofed structures.
- D.** Locations where materials are directly exposed to precipitation and the locations where significant spills or leaks identified in Section A.6.a.iv. below have occurred.
- E.** Areas of industrial activity. This shall include the locations of all storage areas and storage tanks, shipping and receiving areas, fueling areas, vehicle and equipment storage/maintenance areas, material handling and processing areas, waste treatment and disposal areas, dust or particulate generating areas, cleaning and rinsing areas, and other areas of industrial activity which are potential pollutant sources.

V. List of Significant Materials

The SWPPP shall include a list of significant materials handled and stored at the site. For each material on the list, describe the locations where the material is being stored,

received, shipped, and handled, as well as the typical quantities and frequency. Materials shall include raw materials, intermediate products, final or finished products, recycled materials, and waste or disposed materials.

VI. Description of Potential Pollutant Sources

A. The SWPPP shall include a narrative description of the facility's industrial activities, as identified in Section A.4.e above, associated potential pollutant sources, and potential pollutants that could be discharged in storm water discharges or authorized non-storm water discharges. At a minimum, the following items related to a facility's industrial activities shall be considered:

1. **Industrial Processes.** Describe each industrial process, the type, characteristics, and quantity of significant materials used in or resulting from the process, and a description of the manufacturing, cleaning, rinsing, recycling, disposal, or other activities related to the process. Where applicable, areas protected by containment structures and the corresponding containment capacity shall be described.
2. **Material Handling and Storage Areas.** Describe each handling and storage area, type, characteristics, and quantity of significant materials handled or stored, description of the shipping, receiving, and loading procedures, and the spill or leak prevention and response procedures. Where applicable, areas protected by containment structures and the corresponding containment capacity shall be described.
3. **Dust and Particulate Generating Activities.** Describe all industrial activities that generate dust or particulates that may be deposited within the facility's boundaries and identify their discharge locations; the characteristics of dust and particulate pollutants; the approximate quantity of dust and particulate pollutants that may be deposited within the facility boundaries; and a description of the primary areas of the facility where dust and particulate pollutants would settle.
4. **Significant Spills and Leaks.** Describe materials that have spilled or leaked in significant quantities in storm water discharges or non-storm water discharges since April 17, 1994. Include toxic chemicals (listed in 40 CFR, Part 302) that have been discharged to storm water as reported on U.S. Environmental Protection Agency (USEPA) Form R, and oil and hazardous substances in excess of reportable quantities (see 40 Code of Federal Regulations [CFR], Parts 110, 117, and 302).

The description shall include the type, characteristics, and approximate quantity of the material spilled or leaked, the cleanup or remedial actions that have occurred or are planned, the approximate remaining quantity of materials that may be exposed to storm water or non-storm water discharges, and the preventative measures taken to ensure spill or leaks do not reoccur. Such list shall be updated as appropriate during the term of this Permit.

- 5. Non-Storm Water Discharges.** Facility operators shall investigate the facility to identify all non-storm water discharges and their sources. As part of this investigation, all drains (inlets and outlets) shall be evaluated to identify whether they connect to the storm drain system.

All non-storm water discharges shall be described. This shall include the source, quantity, frequency, and characteristics of the non-storm water discharges and associated drainage area.

Non-storm water discharges (other boiler blowdown and boiler condensate permitted under the Order) that contain significant quantities of pollutants or that do not meet the conditions provided in Special Conditions D of the storm water general permit are prohibited by this Permit (Examples of prohibited non-storm water discharges are contact and non-contact cooling water, rinse water, wash water, etc.). Non-storm water discharges that meet the conditions provided in Special Condition D of the general storm water permit are authorized by this Permit. The SWPPP must include BMPs to prevent or reduce contact of non-storm water discharges with significant materials or equipment.

- 6. Soil Erosion.** Describe the facility locations where soil erosion may occur as a result of industrial activity, storm water discharges associated with industrial activity, or authorized non-storm water discharges.

- B.** The SWPPP shall include a summary of all areas of industrial activities, potential pollutant sources, and potential pollutants. This information should be summarized similar to Table B. The last column of Table B, "Control Practices", should be completed in accordance with Section A.8. below.

VII. Assessment of Potential Pollutant Sources

- A.** The SWPPP shall include a narrative assessment of all industrial activities and potential pollutant sources as described in A.6. above to determine:
- 1.** Which areas of the facility are likely sources of pollutants in storm water discharges and authorized non-storm water discharges, and
 - 2.** Which pollutants are likely to be present in storm water discharges and authorized non-storm water discharges. Facility operators shall consider and evaluate various factors when performing this assessment such as current storm water BMPs; quantities of significant materials handled, produced, stored, or disposed of; likelihood of exposure to storm water or authorized non-storm water discharges; history of spill or leaks; and run-on from outside sources.
- B.** Facility operators shall summarize the areas of the facility that are likely sources of pollutants and the corresponding pollutants that are likely to be present in storm water discharges and authorized non-storm water discharges.

Facility operators are required to develop and implement additional BMPs as appropriate and necessary to prevent or reduce pollutants associated with each pollutant source. The BMPs will be narratively described in Section 8 below.

VIII. Storm Water Best Management Practices

The SWPPP shall include a narrative description of the storm water BMPs to be implemented at the facility for each potential pollutant and its source identified in the site assessment phase (Sections A.6. and 7. above). The BMPs shall be developed and implemented to reduce or prevent pollutants in storm water discharges and authorized non-storm water discharges. Each pollutant and its source may require one or more BMPs. Some BMPs may be implemented for multiple pollutants and their sources, while other BMPs will be implemented for a very specific pollutant and its source.

TABLE B
EXAMPLE
ASSESSMENT OF POTENTIAL POLLUTION SOURCES AND
CORRESPONDING BEST MANAGEMENT PRACTICES
SUMMARY

Area	Activity	Pollutant Source	Pollutant	Best Management Practices
Vehicle & Equipment Fueling	Fueling	Spills and leaks during delivery. Spills caused by topping off fuel tanks. Hosing or washing down fuel oil fuel area. Leaking storage tanks. Rainfall running off fuel oil, and rainfall running onto and off fueling area.	fuel oil	Use spill and overflow protection. Minimize run-on of storm water into the fueling area. Cover fueling area. Use dry cleanup methods rather than hosing down area. Implement proper spill prevention control program. Implement adequate preventative maintenance program to preventive tank and line leaks. Inspect fueling areas regularly to detect problems before they occur. Train employees on proper fueling, cleanup, and spill response techniques.

The description of the BMPs shall identify the BMPs as (1) existing BMPs, (2) existing BMPs to be revised and implemented, or (3) new BMPs to be implemented. The description shall also include a discussion on the effectiveness of each BMP to reduce or prevent pollutants in storm water discharges and authorized non-storm water discharges. The SWPPP shall provide a summary of all BMPs implemented for each pollutant source. This information should be summarized similar to Table B.

Facility operators shall consider the following BMPs for implementation at the facility:

A. Non-Structural BMPs

Non-structural BMPs generally consist of processes, prohibitions, procedures, schedule of activities, etc., that prevent pollutants associated with industrial activity from contacting with storm water discharges and authorized non-storm water discharges. They are considered low technology, cost-effective measures. Facility operators should consider all possible non-structural BMPs options before considering additional

structural BMPs (see Section A.8.b. below). Below is a list of non-structural BMPs that should be considered:

1. **Good Housekeeping.** Good housekeeping generally consist of practical procedures to maintain a clean and orderly facility.
2. **Preventive Maintenance.** Preventive maintenance includes the regular inspection and maintenance of structural storm water controls (catch basins, oil/water separators, etc.) as well as other facility equipment and systems.
3. **Spill Response.** This includes spill clean-up procedures and necessary clean-up equipment based upon the quantities and locations of significant materials that may spill or leak.
4. **Material Handling and Storage.** This includes all procedures to minimize the potential for spills and leaks and to minimize exposure of significant materials to storm water and authorized non-storm water discharges.
5. **Employee Training.** This includes training of personnel who are responsible for (1) implementing activities identified in the SWPPP, (2) conducting inspections, sampling, and visual observations, and (3) managing storm water. Training should address topics such as spill response, good housekeeping, and material handling procedures, and actions necessary to implement all BMPs identified in the SWPPP. The SWPPP shall identify periodic dates for such training. Records shall be maintained of all training sessions held.
6. **Waste Handling/Recycling.** This includes the procedures or processes to handle, store, or dispose of waste materials or recyclable materials.
7. **Recordkeeping and Internal Reporting.** This includes the procedures to ensure that all records of inspections, spills, maintenance activities, corrective actions, visual observations, etc., are developed, retained, and provided, as necessary, to the appropriate facility personnel.
8. **Erosion Control and Site Stabilization.** This includes a description of all sediment and erosion control activities. This may include the planting and maintenance of vegetation, diversion of run-on and runoff, placement of sandbags, silt screens, or other sediment control devices, etc.
9. **Inspections.** This includes, in addition to the preventative maintenance inspections identified above, an inspection schedule of all potential pollutant sources. Tracking and follow-up procedures shall be described to ensure adequate corrective actions are taken and SWPPPs are made.
10. **Quality Assurance.** This includes the procedures to ensure that all elements of the SWPPP and Monitoring Program are adequately conducted.

B. Structural BMPs.

Where non-structural BMPs as identified in Section A.8.a. above are not effective, structural BMPs shall be considered. Structural BMPs generally consist of structural devices that reduce or prevent pollutants in storm water discharges and authorized non-storm water discharges. Below is a list of structural BMPs that should be considered:

- 1. Overhead Coverage.** This includes structures that provide horizontal coverage of materials, chemicals, and pollutant sources from contact with storm water and authorized non-storm water discharges.
- 2. Retention Ponds.** This includes basins, ponds, surface impoundments, bermed areas, etc. that do not allow storm water to discharge from the facility.
- 3. Control Devices.** This includes berms or other devices that channel or route run-on and runoff away from pollutant sources.
- 4. Secondary Containment Structures.** This generally includes containment structures around storage tanks and other areas for the purpose of collecting any leaks or spills.
- 5. Treatment.** This includes inlet controls, infiltration devices, oil/water separators, detention ponds, vegetative swales, etc. that reduce the pollutants in storm water discharges and authorized non-storm water discharges.

IX. Annual Comprehensive Site Compliance Evaluation

The facility operator shall conduct one comprehensive site compliance evaluation (evaluation) in each reporting period (July 1-June 30). Evaluations shall be conducted within 8-16 months of each other. The SWPPP shall be revised, as appropriate, and the revisions implemented within 90 days of the evaluation. Evaluations shall include the following:

- A.** A review of all visual observation records, inspection records, and sampling and analysis results.
- B.** A visual inspection of all potential pollutant sources for evidence of, or the potential for, pollutants entering the drainage system.
- C.** A review and evaluation of all BMPs (both structural and non-structural) to determine whether the BMPs are adequate, properly implemented and maintained, or whether additional BMPs are needed. A visual inspection of equipment needed to implement the SWPPP, such as spill response equipment, shall be included.
- D.** An evaluation report that includes, (i) identification of personnel performing the evaluation, (ii) the date(s) of the evaluation, (iii) necessary SWPPP revisions, (iv)

schedule, as required in Section A.10.e, for implementing SWPPP revisions, (v) any incidents of non-compliance and the corrective actions taken, and (vi) a certification that the facility operator is in compliance with this Permit. If the above certification cannot be provided, explain in the evaluation report why the facility operator is not in compliance with this General Permit. The evaluation report shall be submitted as part of the annual report, retained for at least five years, and signed and certified in accordance with Standard Provisions V.D.5 of Attachment D.

X. SWPPP General Requirements

- A.** The SWPPP shall be retained on site and made available upon request of a representative of the Regional Water Board and/or local storm water management agency (local agency) which receives the storm water discharges.
- B.** The Regional Water Board and/or local agency may notify the facility operator when the SWPPP does not meet one or more of the minimum requirements of this Section. As requested by the Regional Water Board and/or local agency, the facility operator shall submit an SWPPP revision and implementation schedule that meets the minimum requirements of this section to the Regional Water Board and/or local agency that requested the SWPPP revisions. Within 14 days after implementing the required SWPPP revisions, the facility operator shall provide written certification to the Regional Water Board and/or local agency that the revisions have been implemented.
- C.** The SWPPP shall be revised, as appropriate, and implemented prior to changes in industrial activities which (i) may significantly increase the quantities of pollutants in storm water discharge, (ii) cause a new area of industrial activity at the facility to be exposed to storm water, or (iii) begin an industrial activity which would introduce a new pollutant source at the facility.
- D.** The SWPPP shall be revised and implemented in a timely manner, but in no case more than 90 days after a facility operator determines that the SWPPP is in violation of any requirement(s) of this Permit.
- E.** When any part of the SWPPP is infeasible to implement due to proposed significant structural changes, the facility operator shall submit a report to the Regional Water Board prior to the applicable deadline that (i) describes the portion of the SWPPP that is infeasible to implement by the deadline, (ii) provides justification for a time extension, (iii) provides a schedule for completing and implementing that portion of the SWPPP, and (iv) describes the BMPs that will be implemented in the interim period to reduce or prevent pollutants in storm water discharges and authorized non-storm water discharges. Such reports are subject to Regional Water Board approval and/or modifications. Facility operators shall provide written notification to the Regional Water Board within 14 days after the SWPPP revisions are implemented.
- F.** The SWPPP shall be provided, upon request, to the Regional Water Board. The SWPPP is considered a report that shall be available to the public by the Regional Water Board under Section 308(b) of the Clean Water Act.

ATTACHMENT H – STATE WATER BOARD MINIMUM LEVELS

The Minimum Levels (MLs) in ppb ($\mu\text{g/L}$) in this appendix are for use in reporting and compliance determination purposes in accordance with section 2.4 of the State Implementation Policy. These MLs were derived from data for priority pollutants provided by State certified analytical laboratories in 1997 and 1998. These MLs shall be used until new values are adopted by the State Water Board and become effective. The following tables (Tables 2a - 2d) present MLs for four major chemical groupings: volatile substances, semi-volatile substances, inorganics, and pesticides and PCBs.

Table 2a - VOLATILE SUBSTANCES*	GC	GCMS
1,1 Dichloroethane	0.5	1
1,1 Dichloroethylene	0.5	2
1,1,1 Trichloroethane	0.5	2
1,1,2 Trichloroethane	0.5	2
1,1,2,2 Tetrachloroethane	0.5	1
1,2 Dichlorobenzene (volatile)	0.5	2
1,2 Dichloroethane	0.5	2
1,2 Dichloropropane	0.5	1
1,3 Dichlorobenzene (volatile)	0.5	2
1,3 Dichloropropene (volatile)	0.5	2
1,4 Dichlorobenzene (volatile)	0.5	2
Acrolein	2.0	5
Acrylonitrile	2.0	2
Benzene	0.5	2
Bromoform	0.5	2
Methyl Bromide	1.0	2
Carbon Tetrachloride	0.5	2
Chlorobenzene	0.5	2
Chlorodibromo-methane	0.5	2
Chloroethane	0.5	2
Chloroform	0.5	2
Chloromethane	0.5	2
Dichlorobromo-methane	0.5	2
Dichloromethane	0.5	2
Ethylbenzene	0.5	2
Tetrachloroethylene	0.5	2
Toluene	0.5	2
Trans-1,2 Dichloroethylene	0.5	1
Trichloroethene	0.5	2
Vinyl Chloride	0.5	2

*The normal method-specific factor for these substances is 1; therefore, the lowest standard concentration in the calibration curve is equal to the above ML value for each substance.

Table 2b - SEMI-VOLATILE SUBSTANCES*	GC	GCMS	LC	COLOR
Benzo (a) Anthracene	10	5		
1,2 Dichlorobenzene (semivolatile)	2	2		
1,2 Diphenylhydrazine		1		
1,2,4 Trichlorobenzene	1	5		

Table 2b - SEMI-VOLATILE SUBSTANCES*	GC	GCMS	LC	COLOR
1,3 Dichlorobenzene (semivolatile)	2	1		
1,4 Dichlorobenzene (semivolatile)	2	1		
2 Chlorophenol	2	5		
2,4 Dichlorophenol	1	5		
2,4 Dimethylphenol	1	2		
2,4 Dinitrophenol	5	5		
2,4 Dinitrotoluene	10	5		
2,4,6 Trichlorophenol	10	10		
2,6 Dinitrotoluene		5		
2- Nitrophenol		10		
2-Chloroethyl vinyl ether	1	1		
2-Chloronaphthalene		10		
3,3' Dichlorobenzidine		5		
Benzo (b) Fluoranthene		10	10	
3-Methyl-Chlorophenol	5	1		
4,6 Dinitro-2-methylphenol	10	5		
4- Nitrophenol	5	10		
4-Bromophenyl phenyl ether	10	5		
4-Chlorophenyl phenyl ether		5		
Acenaphthene	1	1	0.5	
Acenaphthylene		10	0.2	
Anthracene		10	2	
Benzidine		5		
Benzo(a) pyrene		10	2	
Benzo(g,h,i)perylene		5	0.1	
Benzo(k)fluoranthene		10	2	
bis 2-(1-Chloroethoxyl) methane		5		
bis(2-chloroethyl) ether	10	1		
bis(2-Chloroisopropyl) ether	10	2		
bis(2-Ethylhexyl) phthalate	10	5		
Butyl benzyl phthalate	10	10		
Chrysene		10	5	
di-n-Butyl phthalate		10		
di-n-Octyl phthalate		10		
Dibenzo(a,h)-anthracene		10	0.1	
Diethyl phthalate	10	2		
Dimethyl phthalate	10	2		
Fluoranthene	10	1	0.05	
Fluorene		10	0.1	
Hexachloro-cyclopentadiene	5	5		
Hexachlorobenzene	5	1		
Hexachlorobutadiene	5	1		
Hexachloroethane	5	1		
Indeno(1,2,3,cd)-pyrene		10	0.05	
Isophorone	10	1		
N-Nitroso diphenyl amine	10	1		
N-Nitroso-dimethyl amine	10	5		
N-Nitroso -di n-propyl amine	10	5		
Naphthalene	10	1	0.2	
Nitrobenzene	10	1		
Pentachlorophenol	1	5		
Phenanthrene		5	0.05	

Table 2b - SEMI-VOLATILE SUBSTANCES*	GC	GCMS	LC	COLOR
Phenol **	1	1		50
Pyrene		10	0.05	

* With the exception of phenol by colorimetric technique, the normal method-specific factor for these substances is 1,000; therefore, the lowest standard concentration in the calibration curve is equal to the above ML value for each substance multiplied by 1,000.

** Phenol by colorimetric technique has a factor of 1.

Table 2c – INORGANICS*	FAA	GFAA	ICP	ICPMS	SPGFAA	HYDRIDE	CVAA	COLOR	DCP
Antimony	10	5	50	0.5	5	0.5			1,000
Arsenic		2	10	2	2	1		20	1,000
Beryllium	20	0.5	2	0.5	1				1,000
Cadmium	10	0.5	10	0.25	0.5				1,000
Chromium (total)	50	2	10	0.5	1				1,000
Chromium VI	5							10	
Copper	25	5	10	0.5	2				1,000
Cyanide								5	
Lead	20	5	5	0.5	2				10,000
Mercury				0.5			0.2		
Nickel	50	5	20	1	5				1,000
Selenium		5	10	2	5	1			1,000
Silver	10	1	10	0.25	2				1,000
Thallium	10	2	10	1	5				1,000
Zinc	20		20	1	10				1,000

* The normal method-specific factor for these substances is 1; therefore, the lowest standard concentration in the calibration curve is equal to the above ML value for each substance.

Table 2d – PESTICIDES – PCBs*	GC
4,4'-DDD	0.05
4,4'-DDE	0.05
4,4'-DDT	0.01
a-Endosulfan	0.02
alpha-BHC	0.01
Aldrin	0.005
b-Endosulfan	0.01
Beta-BHC	0.005
Chlordane	0.1
Delta-BHC	0.005
Dieldrin	0.01
Endosulfan Sulfate	0.05
Endrin	0.01
Endrin Aldehyde	0.01
Heptachlor	0.01
Heptachlor Epoxide	0.01
Gamma-BHC (Lindane)	0.02
PCB 1016	0.5
PCB 1221	0.5
PCB 1232	0.5

Table 2d – PESTICIDES – PCBs*	GC
PCB 1242	0.5
PCB 1248	0.5
PCB 1254	0.5
PCB 1260	0.5
Toxaphene	0.5

* The normal method-specific factor for these substances is 100; therefore, the lowest standard concentration in the calibration curve is equal to the above ML value for each substance multiplied by 100.

Techniques:

GC - Gas Chromatography

GCMS - Gas Chromatography/Mass Spectrometry

HRGCMS - High Resolution Gas Chromatography/Mass Spectrometry (i.e., EPA 1613, 1624, or 1625)

LC - High Pressure Liquid Chromatography

FAA - Flame Atomic Absorption

GFAA - Graphite Furnace Atomic Absorption

HYDRIDE - Gaseous Hydride Atomic Absorption

CVAA - Cold Vapor Atomic Absorption

ICP - Inductively Coupled Plasma

ICPMS - Inductively Coupled Plasma/Mass Spectrometry

SPGFAA - Stabilized Platform Graphite Furnace Atomic Absorption (i.e., EPA 200.9)

DCP - Direct Current Plasma

COLOR – Colorimetric

ATTACHMENT I – LIST OF PRIORITY POLLUTANTS

CTR Number	Parameter	CAS Number	Suggested Analytical Methods
1	Antimony	7440360	1
2	Arsenic	7440382	1
3	Beryllium	7440417	1
4	Cadmium	7440439	1
5a	Chromium (III)	16065831	1
5a	Chromium (VI)	18540299	1
6	Copper	7440508	1
7	Lead	7439921	1
8	Mercury	7439976	1
9	Nickel	7440020	1
10	Selenium	7782492	1
11	Silver	7440224	1
12	Thallium	7440280	1
13	Zinc	7440666	1
14	Cyanide	57125	1
15	Asbestos	1332214	1
16	2,3,7,8-TCDD	1746016	1
17	Acrolein	107028	1
18	Acrylonitrile	107131	1
19	Benzene	71432	1
20	Bromoform	75252	1
21	Carbon Tetrachloride	56235	1
22	Chlorobenzene	108907	1
23	Chlorodibromomethane	124481	1
24	Chloroethane	75003	1
25	2-Chloroethylvinyl Ether	110758	1
26	Chloroform	67663	1
27	Dichlorobromomethane	75274	1
28	1,1-Dichloroethane	75343	1
29	1,2-Dichloroethane	107062	1
30	1,1-Dichloroethylene	75354	1
31	1,2-Dichloropropane	78875	1
32	1,3-Dichloropropylene	542756	1
33	Ethylbenzene	100414	1
34	Methyl Bromide	74839	1
35	Methyl Chloride	74873	1
36	Methylene Chloride	75092	1
37	1,1,2,2-Tetrachloroethane	79345	1
38	Tetrachloroethylene	127184	1

CTR Number	Parameter	CAS Number	Suggested Analytical Methods
39	Toluene	108883	1
40	1,2-Trans-Dichloroethylene	156605	1
41	1,1,1-Trichloroethane	71556	1
42	1,1,2-Trichloroethane	79005	1
43	Trichloroethylene	79016	1
44	Vinyl Chloride	75014	1
45	2-Chlorophenol	95578	1
46	2,4-Dichlorophenol	120832	1
47	2,4-Dimethylphenol	105679	1
48	2-Methyl-4,6-Dinitrophenol	534521	1
49	2,4-Dinitrophenol	51285	1
50	2-Nitrophenol	88755	1
51	4-Nitrophenol	100027	1
52	3-Methyl-4-Chlorophenol	59507	1
53	Pentachlorophenol	87865	1
54	Phenol	108952	1
55	2,4,6-Trichlorophenol	88062	1
56	Acenaphthene	83329	1
57	Acenaphthylene	208968	1
58	Anthracene	120127	1
59	Benidine	92875	1
60	Benzo(a)Anthracene	56553	1
61	Benzo(a)Pyrene	50328	1
62	Benzo(b)Fluoranthene	205992	1
63	Benzo(ghi)Perylene	191242	1
64	Benzo(k)Fluoranthene	207089	1
65	Bis(2-Chloroethoxy)Methane	111911	1
66	Bis(2-Chloroethyl)Ether	111444	1
67	Bis(2-Chloroisopropyl)Ether	108601	1
68	Bis(2-Ethylhexyl)Phthalate	117817	1
69	4-Bromophenyl Phenyl Ether	101553	1
70	Butylbenzyl Phthalate	85687	1
71	2-Chloronaphthalene	91587	1
72	4-Chlorophenyl Phenyl Ether	7005723	1
73	Chrysene	218019	1
74	Dibenzo(a,h)Anthracene	53703	1
75	1,2-Dichlorobenzene	95501	1
76	1,3-Dichlorobenzene	541731	1
77	1,4-Dichlorobenzene	106467	1
78	3,3'-Dichlorobenzidine	91941	1
79	Diethyl Phthalate	84662	1
80	Dimethyl Phthalate	131113	1
81	Di-n-Butyl Phthalate	84742	1

CTR Number	Parameter	CAS Number	Suggested Analytical Methods
82	2,4-Dinitrotoluene	121142	1
83	2,6-Dinitrotoluene	606202	1
84	Di-n-Octyl Phthalate	117840	1
85	1,2-Diphenylhydrazine	122667	1
86	Fluoranthene	206440	1
87	Fluorene	86737	1
88	Hexachlorobenzene	118741	1
89	Hexachlorobutadiene	87863	1
90	Hexachlorocyclopentadiene	77474	1
91	Hexachloroethane	67721	1
92	Indeno(1,2,3-cd)Pyrene	193395	1
93	Isophorone	78591	1
94	Naphthalene	91203	1
95	Nitrobenzene	98953	1
96	N-Nitrosodimethylamine	62759	1
97	N-Nitrosodi-n-Propylamine	621647	1
98	N-Nitrosodiphenylamine	86306	1
99	Phenanthrene	85018	1
100	Pyrene	129000	1
101	1,2,4-Trichlorobenzene	120821	1
102	Aldrin	309002	1
103	alpha-BHC	319846	1
104	beta-BHC	319857	1
105	gamma-BHC	58899	1
106	delta-BHC	319868	1
107	Chlordane	57749	1
108	4,4'-DDT	50293	1
109	4,4'-DDE	72559	1
110	4,4'-DDD	72548	1
111	Dieldrin	60571	1
112	alpha-Endosulfan	959988	1
113	beta-Endosulfan	33213659	1
114	Endosulfan Sulfate	1031078	1
115	Endrin	72208	1
116	Endrin Aldehyde	7421934	1
117	Heptachlor	76448	1
118	Heptachlor Epoxide	1024573	1
119	PCB-1016	12674112	1
120	PCB-1221	11104282	1
121	PCB-1232	11141165	1
122	PCB-1242	53469219	1
123	PCB-1248	12672296	1
124	PCB-1254	11097691	1

CTR Number	Parameter	CAS Number	Suggested Analytical Methods
125	PCB-1260	11096825	1
126	Toxaphene	8001352	1

1. Pollutants shall be analyzed using the methods described in 40 CFR Part 136

ATTACHMENT J – SUMMARY OF REASONABLE POTENTIAL ANALYSIS

TABLE R1

Boeing SSFL
Outfalls 001, 002, 011, 018 and 019
(CA0001309, CI-6027)

CTRH	DATE	Units	CV	MEC	CTR CRITERIA		Basin Plan	REASONABLE POTENTIAL ANALYSIS (RPA)										HUMAN HEALTH CALCULATIONS		
					Freshwater			Human Health		Tier 1 - Need limit?	B (RD-B-C)	Tier 2 - Need limit?	Tier 3 - Need limit?	AMEL/hh = ECA = C hh O multiplier	Organisms Only	Tier 3 - Need limit?	Tier 3 - other info. ?	Tier 3 - Need limit?	AMEL/hh = ECA = C hh O multiplier	MDEL/hh
					C acute = CMC tot	C chronic = CCC tot		Not applicable C, hh W&O C, hh O	Title 22 GWR											
1	Antimony	µg/L	0.60	1.30	NONE	NONE	14	4300	6	6.0	No	Go to Tier 2	No	No	Yes	Yes	Yes	4300	2.0	8,627
2	Arsenic	µg/L	1.7	35.00	340	150	NONE	NONE	10	10.0	YES	Go to Tier 2	No	No	Yes	Yes	Yes	NONE	3.0	
3	Beryllium	µg/L	2.7	11.00	NONE	NONE	Narrative	Narrative	4	4.0	YES	NO	No	No	Yes	Yes	Yes	Narrative	3.2	
4	Cadmium*	µg/L	0.6	6.90	4.5	2.46	Narrative	Narrative	5	2.5	YES	Go to Tier 2	No	No	Yes	Yes	Yes	Narrative	2.0	
5a	Chromium III*	µg/L	2.6	100.00	1737	207	Narrative	Narrative		207.0	No	Go to Tier 2	No	No	NO	NO	NO	Narrative	3.2	
5b	Chromium VI	µg/L	0.6	0.65	16.3	11.4	Narrative	Narrative	50	11.4	No	Go to Tier 2	No	No	Yes	Yes	Yes	Narrative	2.0	
6	Copper*	µg/L	0.6	100.00	14.0	9.3	1300	NONE		9.3	YES	Yes						NONE	2.0	
7	Lead*	µg/L	0.6	310	81.6	3.2	Narrative	Narrative		3.2	YES	Yes						Narrative	2.0	
8	Mercury	µg/L	1.0	0.32	Reserved	Reserved	0.05	0.051	2	0.05	YES	Yes						0.051	2.5	0.13
9	Nickel*	µg/L	1.3	110	469.17	52.16	610	4600	100	52.16	YES	Go to Tier 2	No	Yes	Yes	Yes	Yes	4600	2.7	12,939
10	Selenium	µg/L	0.6	2.0	Reserved	5	Narrative	Narrative	50	5.00	No	Go to Tier 2	No	No	Yes	Yes	Yes	Narrative	2.01	
11	Silver*	µg/L	0.6	1.00	4.06	none	NONE	NONE		4.06	No	Go to Tier 2	No	No	Yes	Yes	Yes	NONE	2.01	
12	Thallium	µg/L	1.9	1.90	NONE	NONE	1.7	6.3	2	2.00	No	Go to Tier 2	No	No	Yes	Yes	Yes	6.3	3.04	19.15
13	Zinc*	µg/L	0.7	790	120	120	none	NONE		119.82	YES	Go to Tier 2	No	Yes	Yes	Yes	Yes	NONE	2.19	
14	Cyanide	µg/L	0.6	18	22	5.2	700	220,000	200	5.2	YES	Go to Tier 2	No	Yes	Yes	Yes	Yes	220000	2.0	441,361.6
	2,3,7,8-TCDD (Dioxin)	µg/L	0.6	4E-05	NONE	NONE	1.3E-08	1.4E-08	3x10^-5	1.4E-08	YES	Yes						0.000000014	2.01	2.81E-08
19	Benzene	µg/L	0.6	0.84	NONE	NONE	1.2	71	1	1	No	Go to Tier 2	No	No	NO	NO	NO	71	2.01	142
23	Dibromochloromethane	µg/L	0.6	0.98	NONE	NONE	0.401	34	34	34	No	Go to Tier 2	No	No	NO	NO	NO	34	2.01	68
26	Chloroform	µg/L	0.6	19	NONE	NONE	Reserved	Reserved		Reserved	No	Go to Tier 2	NA	NO	NO	NO	NO	Reserved	2.01	
27	Dichlorobromomethane	µg/L	0.6	1.2	NONE	NONE	0.56	46	46	46	No	Go to Tier 2	No	NO	NO	NO	NO	46	2.01	92
29	1,2-dichloroethane	µg/L	0.6	2.4	NONE	NONE	0.38	99	99	0.5	YES	Go to Tier 2	No	Yes	Yes	Yes	Yes	99	2.01	199
30	1,1-Dichloroethylene	µg/L	0.6	0.42	NONE	NONE	0.057	3.2	6	3.2	NO	Go to Tier 2	No	No	Yes	Yes	Yes	3.2	2.01	6

TABLE R1

Boeing SSFL
Outfalls 001, 002, 011, 018 and 019
(CA0001309, CI-6027)

CTR#	DATE	Units	CV	MEC	CTR CRITERIA				REASONABLE POTENTIAL ANALYSIS (RPA)							HUMAN HEALTH CALCULATIONS			
					Freshwater		Human Health		Basin Plan	MEC >= Lowest C	Tier 1 - Need limit? 1)	B (RD) B > C	Tier 2 - Need limit? 2)	Tier 3 - other info. 7	Tier 3 - need limit?	AMEL/hh = ECA = C hh O	MDEL/AMEL multiplier	MDEL_hh	
					C acute = CMC tot	C chronic = CCC tot	Not applicable	C hh W&O C hh O											Title 22 GWR
43	Trichloroethylene	µg/L	0.6	2.4	NONE	NONE	2.7	8.1	5		No	Go to Tier 2		No	NO	Yes	8.1	2.01	163
53	Pentachlorophenol	µg/L	0.6	4	26.4	20.2	0.28	8.2			YES	Go to Tier 2		No	Yes	Yes	8.2	2.01	16
55	2,4,6-Trichlorophenol	µg/L	0.6	4.1	NONE	NONE	2.1	6.5	6.5	ND	No	Go to Tier 2		No	NO	Yes	6.5	2.01	13
68	Bis(2-Ethylhexyl) Phthalate	µg/L	0.6	0.22	NONE	NONE	1.8	5.9	4		No	Go to Tier 2		No	No	Yes	5.9	2.31	14
82	2,4-Dinitrotoluene	µg/L	0.6	0.23	NONE	NONE	0.11	9.1	9.1	ND	No	Go to Tier 2		No	NO	Yes	9.1	2.01	18
98	N-Nitrosodimethylamine	µg/L	0.6	3.7	NONE	NONE	0.00069	8.1	8.1	ND	No	Go to Tier 2		No	NO	Yes	8.1	2.01	16
98	N-Nitrosodiphenylamine	µg/L	0.6	0.15	NONE	NONE	5	16	16	ND	No	Go to Tier 2		No	NO	NO	16	2.01	32
103	alpha-BHC	µg/L	0.6	0.015	NONE	NONE	0.0039	0.013	0.013	ND	No	Go to Tier 2		No	NO	Yes	0.013	2.01	0

FOOTNOTE:
Proposed limits are benchmarks at Outfalls 001 and 002.
The Lowest AMEL is applicable only at Outfall 019, the treated groundwater discharge.
These metals are hardness dependent. CTR criteria was calculated using an average receiving water hardness of 100 µg/L.

TABLE R1

Boeing SSFL
Outfalls 001, 002, 011, 018 and 019
(CA0001309, CI-6027)

CTR#	DATE	Units	AQUATIC LIFE CALCULATIONS						PROPOSED LIMITS		Recommendation Current limitation Included in proposed permit Included in proposed permit Current limitation Included in proposed permit Current limitation Included in proposed permit Current limitation Included in proposed permit Current limitation Included in proposed permit Interim Monitoring - No Limit Current limitation Included in proposed permit 0.03 permit.		
			Freshwater			Freshwater			Lowest AMEL ¹	Lowest MDEL			
			ECA acute multiplier (n=7)	LTA acute	ECA chronic multiplier	LTA chronic	Lowest LTA	AMEL multiplier (n=4)				AMEL acifife (n=4)	MDEL multiplier (n=4)
43	Trichloroethylene	µg/L	0.32		0.53			1.6	13.1	3.11		5	Included in proposed permit
53	Pentachlorophenol	µg/L	0.32	8.46	0.53	10.7	8.5	1.6		3.1	26	16.5	Included in proposed permit
55	2,4,6-trichlorophenol	µg/L	0.32		0.53			1.6		3.1		13.0	Included in proposed permit
68	Bis(2-Ethylhexyl) Phthalate	µg/L	0.24		0.43			1.77		4.1		4.0	Included in proposed permit
82	2,4-Dinitrotoluene	µg/L	0.3		0.5			1.6		3.1		18	Included in proposed permit
96	N-Nitrosodimethylamine	µg/L	0.32		0.53			1.6		3.11		16.3	Included in proposed permit
98	N-Nitrosodiphenylamine	µg/L	0.32		0.53			1.6		3.11		0.01	Interim Monitoring - No Limit Current limitation Included in proposed permit.
103	alpha-BHC	µg/L	0.32		0.53			1.6		3.11		0.03	Included in proposed permit.

FOOTNOTE:
Proposed limits are benchmarks at Outfalls 001 and 002.
The Lowest AMEL is applicable only at Outfall 018, the treated groundwater discharge.
These metals are hardness dependent. CTR criteria was calculated using an average receiving water hardness of 100 µg/L.

Table A3

Reasonable Potential Analysis for Non-Priority Pollutants in Storm water and Wastewater
 The Boeing Company
 (Santa Susana Field Laboratory)
 Outfalls 1,2,11, 18, and 19
 (CA0001309, CI-6027)

CONSTITUENT	Units	Number of Samples	Maximum Observed Effluent Concentration	CV	Multipier	Projected Maximum Effluent Concentration (99/99)	Dilution Ratio	Background Concentration	Projected Maximum Receiving Water Concentration	Water Quality Objectives	BU - Beneficial use protection NC-Human noncarcinogen protection AF-Aquatic life protection	REASONABLE POTENTIAL
Manganese	µg/L	34	11000	4.74	8.19	90124.04	0		90124.04	50	BU	YES
Barium	µg/L	26	2.3	3.33	8.30	19.10	0		19.10	1,000	BU	NO*
Settleable solids	ml/L	106	10	5.34	3.04	30.38	0		30.38	0.3	BU	YES
Iron	µg/L	43	97.00	2.57	4.49	435.33	0		435.33	0.3	BU	YES
MBAS	mg/L	107	10	3.11	2.52	25.18	0		25.18	0.5	BU	YES
TSS	mg/L	107	33000	8.76	3.50	115360	0		115360	45.00	BU	YES
Perchlorate	µg/L	107	2.00	0.37	1.24	2.47	0		2.47	6.00	BU	NO*
Nitrate + Nitrite as Nitrogen	mg/L	104	10.00	1.33	1.86	18.58	0		18.58	8.0	BU	YES
Fluoride	mg/L	24	0.50	0.34	1.58	0.79	0		0.79	1.6	BU	NO*
Oil and Grease	mg/L	107	17.00	0.82	1.54	26.17	0		26.17	10	BU	YES
Sulfate	mg/L	107	400.00	1.10	1.71	683.19	0		683.19	300	BU	YES
BOD ₅ 20°C	mg/L	105	33.00	1.51	1.94	64.08	0		64.08	20	BU	YES
Chloride	mg/L	107	84.00	0.70	1.46	122.57	0		123	150	BU	NO*
Total Dissolved Solids	mg/L	107	1000.00	0.68	1.45	1447.10	0		1447	950	BU	YES
Boron	mg/L	24	0.22	0.66	2.31	0.51	0		0.51	1.0	BU	NO
Gross Alpha	pCi/L	33	17.3	1.37	3.45	59.62	0		59.62	15	BU	YES
Gross Beta	pCi/L	29	20	0.76	2.38	47.54	0		47.54	50	BU	NO*
Strontium-90	pCi/L	26	2.79	5.19	11.57	32.28	0		32.28	8.0	BU	YES
Combined Radium 226 and Radium 228	pCi/L	21	17.01	3.38	10.38	176.53	0		176.53	5.0	BU	YES
Tritium	pCi/L	25	230	-11.67	20.67	4753.64	0		4754	20000	BU	NO*
Ammonia as Nitrogen	mg/L	107	13	2.47	2.32	30.11	0		30.11	10	BU	YES
Nitrate as Nitrogen	mg/L	18	3.8	1.25	4.60	17.50	0		17.50	8.00	BU	YES
Nitrite as Nitrogen	mg/L	8	0.20	1.53	0.23	0.23	0		0.23	1.00	BU	NO*
Total Residual Chlorine	mg/L	22	0.17	0.58	2.19	0.37	0		0.37	0.10	BU	NO*

* Limitation retained based on BPJ.

TABLE R1

Boeing SSFL
Outfalls 003-010
(CA0001309, CI-6027)

CTR#	DATE	Units	CV	MEC	CTR CRITERIA			REASONABLE POTENTIAL ANALYSIS (RPA)										HUMAN HEALTH CALCULATIONS	
					Freshwater		Human Health		Basin Plan		MEC >= Lowest C	Tier 1 - limit?	B (RD)	Tier 2 - Need limit?	Tier 3 - other info?	Tier 3 - need limit?	AMEL/AMEL-ECA = C th O multiplier	Organisms Only	
					C acute = CMC-101	C chronic = CCC-101	Not applicable C th W&O	C th O	Title 22 SWR	Lowest C									
1	Antimony	µg/L	2.77	35.00	NONE	NONE	14	4500	6	6.0	YES	Go to Tier 2	No	No	Yes	Yes	4300	3.2	13,877
2	Arsenic	µg/L	1.0	27.00	340	190	NONE	NONE	10	10.0	YES	Go to Tier 2	No	No	Yes	Yes	NONE	2.6	
3	Beryllium	µg/L	0.6	0.00	NONE	NONE	Narrative	Narrative	4	4.0	No	No	No	No	Yes	Yes	Narrative	2.0	
4	Cadmium*	µg/L	3.9	9.20	4.5	2.46	Narrative	Narrative	5	2.5	YES	Go to Tier 2	No	No	Yes	Yes	Narrative	3.4	
5a	Chromium III*	µg/L	0.8	14.00	1737	207	Narrative	Narrative		207.0	No	Go to Tier 2	No	No	NO	NO	Narrative	2.4	
5b	Chromium VI	µg/L	0.6	NA	16.3	11.4	Narrative	Narrative	50	11.4	YES	Go to Tier 2	No	No	Yes	Yes	Narrative	2.0	
6	Copper*	µg/L	1.065	39.00	14.0	9.3	1300	NONE		9.3	YES	Yes	Yes	Yes	Yes	Yes	NONE	2.6	
7	Lead*	µg/L	4.2	260	81.6	3.2	Narrative	Narrative		3.2	YES	Yes	Yes	Yes	Yes	Yes	Narrative	3.4	
8	Mercury	µg/L	1.2	0.89	Reserved	Reserved	0.05	0.051	2	0.05	YES	Yes	Yes	Yes	Yes	Yes	0.051	2.7	0.14
9	Nickel*	µg/L	1.0	15	469.17	52.16	610	4600	100	52.16	No	Go to Tier 2	No	No	No	No	4600	2.5	11512
10	Selenium	µg/L	0.5	8.8	Reserved	5	Narrative	Narrative	50	5.00	YES	Go to Tier 2	No	No	Yes	Yes	Narrative	2.01	
11	Silver ¹	µg/L	0.6	4.1	4.06	note	NONE	NONE		4.06	YES	Go to Tier 2	No	No	NO	NO	NONE	2.01	
12	Thallium	µg/L	0.6	7.00	NONE	NONE	1.7	6.3	2	2.00	YES	Go to Tier 2	No	No	Yes	Yes	6.3	2.01	12.64
13	Zinc*	µg/L	1.2	91	120	120	none	NONE		119.82	No	Go to Tier 2	No	No	Yes	Yes	NONE	2.67	
14	Cyanide	µg/L	1.1	9.6	22	5.2	700	220,000	200	5.20	YES	Go to Tier 2	No	Yes	Yes	Yes	220000	2.6	565293.5
	2,3,7,8-TCDD (Dioxin)	µg/L	10.8	9E-04	NONE	NONE	1.3E-08	1.4E-08	3x10 ⁻⁵	1.4E-08	YES	Go to Tier 2	No	Yes	Yes	Yes	0.00000014	3.90	5.47E-08
20	Bromofom	µg/L	0.6	3.1	NONE	NONE	4.3	360	ND	360	No	Go to Tier 2	No	No	NO	NO	360	2.01	722
35	Methyl chloride	µg/L	0.6	0.43	NONE	NONE	Narrative	Narrative		Narrative	ND	Go to Tier 2	No	NO	NO	NO	Narrative	2.01	
36	Methylene chloride	µg/L	0.6	1.4	NONE	NONE	4.7	1,600		1,600	ND	Go to Tier 2	No	NO	NO	NO	1600	2.01	3210
41	1,1,1-Trichloroethane	µg/L	0.6	0.76	NONE	NONE	Narrative	Narrative	200	200	No	Go to Tier 2	No	NO	NO	NO	Narrative	2.01	
43	Trichloroethylene	µg/L	0.6	0.66	NONE	NONE	2.7	81	5	5	No	Go to Tier 2	No	NO	NO	NO	81	2.01	163
104	beta-BHC	µg/L	0.6	0.0052	NONE	NONE	0.014	0.046		0.046	ND	Go to Tier 2	No	NO	NO	NO	0.046	2.01	0.09
110	Endrin Alkalyde	µg/L	0.6	0.0027	NONE	NONE	0.76	0.81		0.81	ND	Go to Tier 2	No	NO	NO	NO	0.81	2.01	1.6

FOOTNOTE:
1) The detected concentration for Silver was a DNQ value.

TABLE R1

Boeing SSFL
Outfalls 003-010
(CA0001309, CI-6027)

CTR#	DATE	Units	AQUATIC LIFE CALCULATIONS						AQUATIC LIFE CALCULATIONS				PROPOSED LIMITS		Recommendation Current limitation Included in proposed permit. Interim monitoring - No limitation included. Interim monitoring - No limitation included. Current limitation Included in proposed permit. No RPA at either Outfall. No effluent limit applied. Interim monitoring - No limitation included. Current limitation Included in proposed permit. Current limitation Included in proposed permit. Current limitation Included in proposed permit. Current limitation Included in proposed permit. Current limitation Included in proposed permit. New limitation incorporated. Current limitation Included in proposed permit. Interim Monitoring - No Limit No Limit - No Criteria Available Interim Monitoring - No Limit Interim Monitoring - No Limit Interim Monitoring - No Limit Interim Monitoring - No Limit Interim Monitoring - No Limit	
			Freshwater			Freshwater			Freshwater		Freshwater		Lowest AMEL	Lowest MDEL		
			ECA acute multiplier (p.7)	LTA acute	ECA chronic multiplier	LTA chronic	Lowest LTA	AMEL multiplier (n=4)	AMEL aq.life (n=4)	MDEL multiplier (n=4)	MDEL aq.life					
1	Antimony	µg/L	0.10		0.15			3.2			10.4			6.0		
2	Arsenic	µg/L	0.20	68.2	0.37	55.1		2.0	108.2		5.0	274.6				
3	Beryllium	µg/L	0.32		0.53			1.8			3.1					
4	Cadmium*	µg/L	0.08	0.4	0.12	0.3	0.3	3.6	1.1	12.0		3.5		4.0		
5a	Chromium III*	µg/L	0.22	382.9	0.40	82.4	82.4	1.9	153.7	4.5	373.9					
5b	Chromium VI	µg/L	0.32	5.2	0.53	6.0	6.2	1.6	8.1	3.1	16.3					
6	Copper*	µg/L	0.19	2.7	0.35	3.31	2.7	2.0	5.4	5.2	14.0			14.0		
7	Lead*	µg/L	0.08	6.8	0.11	0.4	0.4	3.6	1.3	12.3	4.5			5.2		
8	Mercury	µg/L	0.17		0.32			2.1		5.7				0.1		
9	Nickel*	µg/L	0.21	97.2	0.38	19.7	19.7	1.9	38	4.8	95			100		
10	Selenium	µg/L	0.32		0.53	2.6	2.6	1.6	4	3.1	8			5.0		
11	Silver ¹	µg/L	0.32	1.3	0.53		1.3	1.6	2	3.1	4					
12	Thallium	µg/L	0.32		0.53			1.6		3.1				2.0		
13	Zinc*	µg/L	0.18	21.3	0.33	39.3	21.3	2.1	45	5.6	120			159		
14	Cyanide	µg/L	0.2	4.3	0.36	1.9	1.9	2.0	3.7	5.1	9.5			9.5		
	2,3,7,8-TCDD (Dioxin)	µg/L	0.07		0.1			3.8		14.8				2.8E-08		
20	Bromoforn	µg/L	0.3		0.53			1.6		3.11						
35	Methyl chloride	µg/L	0.3		0.53			1.6		3.11						
36	Methylene chloride	µg/L	0.3		0.53			1.6		3.11						
41	1,1,1-Trichloroethane	µg/L	0.3		0.53			1.6		3.11						
43	Trichloroethylene	µg/L	0.32		0.53			1.6		3.11						
104	Isia-BHC	µg/L	0.32		0.53			1.6		3.11						
116	Endrin Aldehyde	µg/L	0.32		0.53			1.6		3.11						
	FOOTNOTE:	µg/L	0.32		0.53			1.6		3.11						

¹ The detected concentration for Silver was a

TABLE R1
 Boeing SSFL
 Outfalls 003-010
 (CA0001309, CI-6027)

CTR#	DATE These metals are hardness dependent. CTR criteria was calculated using an average receiving water hardness of 100 mg/L.	CTR CRITERIA			REASONABLE POTENTIAL ANALYSIS (RPA)							HUMAN HEALTH CALCULATIONS					
		Freshwater		Human Health	Basin Plan	MEC	CV	Units	Lowest C	MEC >= Lowest C	Tier 1 - Need limit?	B (RD) B > C	Tier 2 - Need limit?	Tier 3 - other info. ?	Tier 3 - need limit?	AMEL/hh = ECA = C hh O multiplier	MDEL/hh
		C acute = CMC tot	C chronic = CCC tot	Not applicable C hh W&D C hh O													

TABLE R1

Boeing SSFL
Outfalls 003-010
(CA0001309, CI-6027)

CTR#	DATE These metals are hardness dependent. CTR criteria was calculated using an average receiving water hardness of 100 mg/L.	AQUATIC LIFE CALCULATIONS					AQUATIC LIFE CALCULATIONS			PROPOSED LIMITS		Recommendation		
		Freshwater		Freshwater			Freshwater		Lowest AMEL	Lowest MDEL	Lowest MDEL			
		ECA acute multiplier (p-7)	LTA acute	ECA chronic multiplier	LTA chronic	Lowest LTA	AMEL multiplier (n=4)	AMEL aq.life (n=4)					MDEL multiplier (n=4)	MDEL aq.life

Table A3

Reasonable Potential Analysis for Non-Priority Pollutants in Storm Water Runoff
 The Boeing Company
 (Santa Susana Field Laboratory)
 Outfalls 003-010
 (CA0001309, CI-6027)

CONSTITUENT	Units	Number of Samples	Maximum Observed Effluent Concentration	CV	Multiplier	Projected Maximum Effluent Concentration (99/99)	Dilution Ratio	Background Concentration	Projected Maximum Receiving Water Concentration	Water Quality Objectives	BU - Beneficial use protection	NC-Human noncarcinogen protection	AP-Aquatic life protection	REASONABLE POTENTIAL
Perchlorate	µg/L	69	2.00	0.70	1.66	3.33	0		3.33	6.00	BU	BU	NO*	
Nitrate + Nitrite as Nitrogen	mg/L	211	51.00	2.17	1.49	76.22	0		76.22	8.0	BU	BU	YES	
Fluoride	mg/L	17	0.46	0.27	1.54	0.71	0		0.71	1.6	BU	BU	NO*	
Oil and Grease	mg/L	227	16.00	1.45	1.34	21.41	0		21.41	10	BU	BU	YES	
Sulfate	mg/L	227	240.00	1.41	1.33	319.90	0		319.90	300	BU	BU	YES	
Chloride	mg/L	227	210.00	1.46	1.34	281.45	0		281.45	150	BU	BU	NO*	
Total Dissolved Solids	mg/L	240	980.00	0.76	1.19	1162.01	0		1162	950	BU	BU	YES	
Boron	mg/L	33	0.21	1.20	3.12	0.65	0		0.65	1.0	BU	BU	NO*	
Gross Alpha	pCi/L	80	16.3	1.50	2.23	36.28	0		36.28	15	BU	BU	YES	
Gross Beta	pCi/L	83	64	1.20	1.97	125.90	0		125.90	50	BU	BU	NO*	
Strontium-90	pCi/L	75	11.4	3.17	3.29	37.45	0		37.45	8.0	BU	BU	YES	
Combined Radium 226 and Radium 228	pCi/L	55	2.167	1.44	2.66	5.77	0		5.77	5.0	BU	BU	YES	
Tritium	pCi/L	67	300	-6.54	4.95	1486.39	0		1486.39	20000	BU	BU	NO*	
Ammonia as Nitrogen	mg/L	4	1.1	1.23	14.68	16.14	0		16.14	10	BU	BU	YES	
Nitrate as Nitrogen	mg/L	4	7.7	0.55	4.26	32.78	0		32.78	8.00	BU	BU	YES	
Nitrite as Nitrogen	mg/L	4	0.09	0.55	4.26	0.38	0		0.38	1.00	BU	BU	NO*	

TABLE R1

Boeing SSFL
Outfalls 012-014
(CA0001309, CI-6027)

CTR#	DATE	Units	CV	MEC	CTR CRITERIA				REASONABLE POTENTIAL ANALYSIS (RPA)										HUMAN HEALTH CALCULATIONS	
					Freshwater		Human Health		Basin Plan	Lowest C	MEC >= Lowest C	Tier 1 - Need limit? Go to Tier 2	B (RD)	Tier 2 - Need limit?	Tier 3 - other info.	Tier 3 - need limit?	ANEL fth = ECA = C th O	MDEL/ANEL multiplier	MDEL fth	
					C acute = CMC tot	C chronic applicable = CCC tot C th W&O	Not applicable C th O	Ti Ne 22 GWR												
1	Ammony	µg/L	0.60	3.30	NONE	NONE	14	4300	6	6.0	No	No	No	No	4300	2.0	8,627			
2	Arsenic	µg/L	0.6	7.00	340	NONE	NONE	NONE	10	10.0	No	No	No	No	NONE	2.0				
3	Beryllium	µg/L	0.6	0.90	NONE	NONE	Narrative	Narrative	4	4.0	No	No	No	No	Narrative	2.0				
4	Cadmium*	µg/L	1.0	5.20	4.5	2.46	Narrative	Narrative	5	2.5	YES	Yes	Yes	Yes	Narrative	2.5				
5a	Chromium III*	µg/L	0.6	5.20	1737	207	Narrative	Narrative		207.0	No	No	No	No	Narrative	2.0				
6	Copper*	µg/L	0.400	12.00	14.0	9.3	1300	NONE		9.3	YES	Yes	Yes	Yes	NONE	1.7				
7	Lead*	µg/L	0.5	6	81.6	3.2	Narrative	Narrative		3.2	YES	Yes	Yes	Yes	Narrative	1.8				
8	Mercury	µg/L	0.6	0.12	Reserved	Reserved	0.05	0.051	2	0.05	YES	Yes	Yes	Yes	0.051	2.0	0.10			
9	Nickel*	µg/L	0.6	4.5	469.17	52.16	610	4600	100	52.16	No	No	No	No	4600	2.0	9228			
10	Selenium	µg/L	1.6	1.4	Reserved	5	Narrative	Narrative	50	5.00	No	No	Yes	Yes	Narrative	2.93				
11	Silver*	µg/L	0.6	ND	4.06	none	NONE	NONE		4.06	No	No	No	No	NONE	2.01				
12	Thallium	µg/L	0.6	0.35	NONE	NONE	1.7	6.3	2	2.00	No	No	No	No	6.3	2.01	12.64			
13	Zinc*	µg/L	0.7	92	120	120	none	NONE		119.82	No	No	Yes	Yes	NONE	2.19				
14	Cyanide	µg/L	0.6	4.3	22	5.2	700	220,000	200	5.2	No	Yes	Yes	Yes	220000	2.0	441361.6			
	2,3,7,8-TCDD (Dioxin TEQs)	µg/L	0.6	1E-06	NONE	NONE	1.3E-08	1.4E-08	3x10^-5	1.4E-08	YES	Yes	Yes	Yes	0.00000014	2.01	2.81E-08			
19	Benzene	µg/L	0.6	0.71	NONE	NONE	1.2	71	1	1	No	No	No	No	71	2.01	142			
20	Bromofom	µg/L	0.6	0.66	NONE	NONE	4.3	360		360	ND	No	No	No	360	2.01	722			
23	Dibromochloromethane	µg/L	0.6	1.3	NONE	NONE	0.401	34		34	No	No	No	No	34	2.01	68			
26	Chlorofom	µg/L	0.5	0.66	NONE	NONE	Reserved	Reserved	Reserved	Reserved	No	No	No	MA	Reserved	2.01				
27	Dichlorobromomethane	µg/L	0.6	1.1	NONE	NONE	0.66	46		46	No	No	No	No	46	2.01	92			
33	Ethylbenzene	µg/L	0.6	0.6	NONE	NONE	3100	26,000	0.7	0.7	No	No	No	No	29000	2.01	58179			
39	Toluene	µg/L	0.6	3	NONE	NONE	6600	200,000	150	150	ND	No	No	No	200000	2.01	401238			

TABLE R1

Boeing SSFL
Outfalls 012-014
(CA0001308, CI-6027)

CTR#	DATE	Units	AQUATIC LIFE CALCULATIONS										PROPOSED BENCHMARKS		Recommendation
			Freshwater					Freshwater					Lowest AMEL	Lowest MDEL	
			ECA acute multiplier (P.7)	LTA acute	ECA chronic multiplier	LTA chronic	AMEL multiplier (N-4)	AMEL aq.life (N-4)	MDEL multiplier (N-4)	MDEL aq.life					
1	Antimony	µg/L	0.32	0.53	0.53	79.1	79.1	1.6	122.8	3.1	246.4	3.1	3.1	Interim Monitoring - No Limit	
2	Arsenic	µg/L	0.32	0.53	0.53	79.1	79.1	1.6	122.8	3.1	246.4	3.1	3.1	Interim Monitoring - No Limit	
3	Beryllium	µg/L	0.32	0.53	0.53	79.1	79.1	1.6	122.8	3.1	246.4	3.1	3.1	Interim Monitoring - No Limit	
4	Cadmium*	µg/L	0.21	0.38	0.9	0.9	0.9	1.9	1.8	4.8	4.5	3.1	3.1	Current benchmark included in proposed permit.	
5a	Chromium III*	µg/L	0.32	0.53	109.2	109.2	1.6	169.5	3.1	340.0	14	14	14	Interim Monitoring - No Limit	
6	Copper*	µg/L	0.44	0.64	6.0	6.0	1.4	8.2	2.3	5.2	5.2	5.2	5.2	Benchmark retained.	
7	Lead*	µg/L	0.37	0.56	1.8	1.8	1.5	2.7	2.7	3.1	3.1	3.1	3.1	Benchmark retained.	
8	Mercury	µg/L	0.32	0.53	27.5	27.5	1.6	43	3.1	86	86	86	86	Benchmark retained.	
9	Nickel*	µg/L	0.32	0.53	27.5	27.5	1.6	43	3.1	86	86	86	86	Benchmark retained.	
10	Selenium	µg/L	0.14	0.25	1.2	1.2	2.5	3	7.3	9	9	9	9	Benchmark retained.	
11	Silver*	µg/L	0.32	0.53	1.3	1.3	1.6	2	3.1	4	4	4	4	Interim Monitoring - No Limit	
12	Thallium	µg/L	0.32	0.53	0.53	0.53	1.6	1.6	3.1	3.1	3.1	3.1	3.1	Interim Monitoring - No Limit	
13	Zinc*	µg/L	0.27	0.47	56.2	56.2	1.7	56	3.7	120	120	120	120	Benchmark retained.	
14	Cyanide	µg/L	0.3	0.53	2.7	2.7	1.6	4.3	3.1	8.5	8.5	8.5	8.5	Interim Monitoring - No Limit	
	2,3,7,8-TCDD (Dioxin TEQs)	µg/L	0.32	0.5	0.5	0.5	1.6	1.6	3.1	3.1	3.1	3.1	3.1	Benchmark retained.	
19	Benzene	µg/L	0.3	0.53	0.53	0.53	1.6	1.6	3.1	3.1	3.1	3.1	3.1	Interim Monitoring - No Limit	
20	Bromoform	µg/L	0.3	0.53	0.53	0.53	1.6	1.6	3.1	3.1	3.1	3.1	3.1	Interim Monitoring - No Limit	
23	Dibromochloromethane	µg/L	0.3	0.53	0.53	0.53	1.6	1.6	3.1	3.1	3.1	3.1	3.1	Interim Monitoring - No Limit	
26	Chloroform	µg/L	0.3	0.53	0.53	0.53	1.6	1.6	3.1	3.1	3.1	3.1	3.1	Interim Monitoring - No Limit	
27	Dichlorobromomethane	µg/L	0.3	0.53	0.53	0.53	1.6	1.6	3.1	3.1	3.1	3.1	3.1	Interim Monitoring - No Limit	
33	Ethylbenzene	µg/L	0.3	0.53	0.53	0.53	1.6	1.6	3.1	3.1	3.1	3.1	3.1	Interim Monitoring - No Limit	
39	Toluene	µg/L	0.3	0.53	0.53	0.53	1.6	1.6	3.1	3.1	3.1	3.1	3.1	Interim Monitoring - No Limit	

TABLE R1

Boeing SSFL
Outfalls 012-014
(CA0001309, CI-6027)

CTR#	DATE	CTR CRITERIA				REASONABLE POTENTIAL ANALYSIS (RPA)										HUMAN HEALTH CALCULATIONS	
		Freshwater		Human Health		Basin Plan		MEC >= Lowest C	Tier 1 - Need limit? Go to Tier 2	Tier 1 - B (RD) B-C	Tier 2 - Need limit?	Tier 3 - other info?	Tier 3 - need limit?	AMEL/AMEL ECA = C th O multiplier	MDEL/AMEL multiplier	MDEL th	
		C acute = CMC tot	C chronic = CCC tot	Not applicable	Human Health	Human Health	Basin Plan										
43	Trichloroethylene	0.6	1.4	NONE	NONE	2.7	81	5	No	No	NO	Yes	81	2.01	163		
54	Phenol	0.6	7.2	NONE	NONE	21,000	4,600,000	4.6x10 ⁶	ND	No	NO	NO	4600000	2.01	9228470		
57	Acanaphthylene	0.6	12	NONE	NONE	NONE	NONE	ND	No Criteria Available	No	NO	NO	NONE	2.01			
94	Napthalene	0.9515	73	NONE	NONE	NONE	NONE	21	No Criteria Available	No	NO	NO	NONE	2.47			
99	Phenanthrene	0.6	4.9	NONE	NONE	NONE	NONE	ND	No Criteria Available	NA	NO	NO	NONE	2.01			
FOOTNOTE: These metals are hardness dependent. CTR criteria was calculated using an average receiving water hardness of 100 mg/L.																	

TABLE R1
Boeing SBFL
Outfalls 012-014
(CA0001309, CH6027)

CTR#	DATE	Units	AQUATIC LIFE CALCULATIONS						AQUATIC LIFE CALCULATIONS			PROPOSED BENCHMARKS			Recommendation	
			Freshwater			Freshwater			Freshwater			Freshwater				
			ECA acute multiplier (6.7)	LTA acute	ECA chronic multiplier	LTA chronic	Lowest LTA	AMEL multiplier (n=4)	AMEL ac.life (n=4)	MDEL multiplier (n=4)	MDEL ac.life	Lowest AMEL	Lowest MDEL	Lowest MDEL		
43	Trichloroethylene	µg/L	0.32		0.53			1.6			3.11					Interim Monitoring - No Limit
54	Phenol	µg/L	0.32		0.53			1.6			3.1					Interim Monitoring - No Limit
57	Acenaphthylene	µg/L	0.32		0.53			1.6			3.11					Interim Monitoring - No Limit
94	Naphthalene	µg/L	0.21		0.39			1.9			4.69			21		Benchmark retained.
98	Phenanthrene	µg/L	0.32		0.53			1.6			3.11					Interim Monitoring - No Limit
FOOTNOTE:		These metals are hardness dependent. CTR criteria was calculated using an average receiving water hardness of 100 mg/L.														

APPENDIX B

Best Management Practices Plan (BMPP) and Pollutant
Minimization Plan (PMP) (Non-Storm Water)

Best Management Practices Plan
and
Pollution Minimization Plan

The Boeing Company
Santa Susana Field Laboratory

NPDES Permit No. CA0001309
October 31, 2012

Table of Contents

<u>Section</u>	<u>Page No.</u>
I. Introduction	1
II. Site Description and Background	2
III. Facilities Utilizing Chemicals and Products That Could Potentially Contaminate Non-Storm Water Discharges	2
IV. Non-structural BMPs and Program Administration	4
V. Structural BMPs	5
VI. Proposed BMPs and Implementation Schedule	8

SSFL Best Management Practices Plan
NPDES Permit No. CA0001309

Page 1

I. INTRODUCTION

Federal regulations resulting from implementation of the 1972 Clean Water Act require development of Best Management Practice (BMP) plans for facilities using any chemical or other materials listed in Section 307(a)(1) of the Clean Water Act (CWA), or any pollutant listed as hazardous under Section 311 of the CWA which is used in significant quantities. As a result, the Santa Susana Site (Site) developed a BMP plan in 1981 and has adopted best management practices in Site operations site-wide to ensure pollution of waterways and the environment is minimized to the maximum extent possible.

As a direct discharger of surface water to the waters of the state, The Boeing Company's (Boeing) Santa Susana Field Laboratory (Santa Susana Site) is regulated by a National Pollutant Discharge Elimination System (NPDES) Permit issued by the Los Angeles Regional Water Quality Control Board (LARWQCB). Through the permit renewal process, the Santa Susana Site NPDES permit has undergone significant modification and was reissued on July 1, 2004; March 17, 2006; November 9, 2007; May 8, 2009; and more recently on June 3, 2010. Included in the current permit is a condition requiring the development and implementation of a Best Management Practices Plan (BMPP) for non-storm water discharges and a Pollution Minimization Plan (PMP) for maintaining Organochlorine (OC) pesticides (OCP) and polychlorinated biphenyls (PCBs) effluent concentrations at or below Receiving Water Limitations.

The objective of this document is to establish site-specific procedures that will prevent the discharge of pollutants in non-storm water discharges. The BMPP and PMP cover all areas of the Site. To reduce the duplication of efforts and to provide continuity, this BMPP/PMP is now part of the Santa Susana Site Storm Water Pollution Prevention Plan (SWPPP). Where applicable, information will be cited by reference to the various elements of the SWPPP.

A BMP plan was originally prepared in 1993 to document the status of the implementation of BMP's specific to Fuels Propellants and Oxidizers. A second BMP plan, implemented in 1994, addressed Solvent usage and disposal. This BMPP/PMP documents the adoption of those BMPs and OCPs/PCBs into Site operations site-wide. The objective of the program is as follows:

1. To eliminate, where possible, the introduction of chemicals into the Santa Susana Site surface water retention system.
2. To ensure the proper disposal of waste chemicals to minimize impact to the environment.

The current controls and management practices in place at the Santa Susana Site allow for the protection of the environment and waterways such that the objectives of this BMPP/PMP are being achieved on a consistent basis.

SSFL Best Management Practices Plan

NPDES Permit No. CA0001309

Page 2

II. SITE DESCRIPTION AND BACKGROUND

See Section 3.0 of the SWPPP

III. FACILITIES UTILIZING CHEMICALS AND PRODUCTS THAT COULD POTENTIALLY CONTAMINATE NON-STORM WATER DISCHARGES.

General

In general, the chemicals that are currently used at the Santa Susana Site are related to remediation operations, demolition activities, BMP construction and facility support. Facilities that store chemicals in quantities greater than 55 gallons per container are equipped with secondary containment. Appendix C of the SWPPP contains an inventory of all significant materials as well as a complete list of chemicals used in each building at the Site.

All chemical purchases at Santa Susana Site require approval from the Environmental Health and Safety department before a purchase order may be issued. Purchase requests that are not approved are reviewed with the requesting party to explain why the order was turned down and query personnel as to the reason the request was made. This approval process has become a very important part of the current chemical usage and tracking system.

Chemicals used at the Santa Susana Site are received in a variety of containers. Global containers are typically delivered directly to the using department by vendors or off loaded at the Site's receiving area then delivered to the appropriate area by the Santa Susana Site Transportation Department. Chemical usage at the Site is strictly monitored and controlled by internal methods as well as outside agencies. The Ventura County Air Pollution Control District (VCAPCD) sets limits on the volumes of some materials to use. To ensure compliance with regulations, an extensive record keeping system is in place to track the volume of chemicals covered by VCAPCD permits.

Other Agencies, such as the Los Angeles RWQCB and the California Department of Toxic Substance Control (DTSC), indirectly limit how and where chemicals are used as well as how they are disposed of. Strict surface water discharge limits have been in place at the Santa Susana Site for several years, and the Site has adopted very conservative requirements on how, when and where chemicals are used, as well as how wastes are disposed of. Internal Boeing procedures along with DTSC regulations ensure the proper handling, storage and disposal of all wastes generated at the Santa Susana Site. A complete inventory of liquid waste shipped offsite for treatment and or disposal is reported in the NPDES quarterly discharge monitoring reports.

SSFL Best Management Practices Plan

NPDES Permit No. CA0001309

Page 3

AREA I:

Fire Station Building 1319

This building is for the storage and maintenance of fire fighting vehicles, and related materials such as ansulite ARC (Foam) and oxygen gas.

Best Management Practices in Place:

Significant materials are either stored inside or outside in approved storage cabinets or secondary containment. The building is inspected on a monthly basis.

Area I: Hazardous Waste Storage Yard Building 1407

The Area I Hazardous Waste Storage Yard is currently the 90-day storage facility for Boeing hazardous waste at the Santa Susana Site. All hazardous waste is stored inside or in approved containers, and is transported offsite for disposal.

Best Management Practices in Place:

Significant materials are either stored inside or outside in approved storage cabinets or secondary containment. The building is inspected on a monthly basis.

Area I: Building 1449 – Groundwater Extraction and Treatment System

Building 1449 is currently the active GETS facility. This facility treats extracted groundwater from of the Santa Susana Site. Hydrogen Peroxide, compressed air, calcium chloride, lubricating oil, and waste solvents for field test kits are stored at this facility.

Best Management Practices in Place:

Significant materials are either stored inside or outside in approved storage cabinets or secondary containment. The building is inspected on a monthly basis.

Area I: Outfall 011 Stormwater Treatment System (SWTS) – Perimeter Pond

The Outfall 011 SWTS is a high-performing treatment system that treats stormwater from its surrounding watershed stormwater that is conveyed from Outfall 014 prior to discharge as discussed in Section 3.5. Chemicals used in the treatment process are aluminum sulfate, anionic polymer, hydrochloric acid, sodium hydroxide and potassium permanganate.

Best Management Practices in Place:

Significant materials are either stored in approved storage cabinets or secondary containment. The building is inspected on a monthly basis.

AREA II

Area II: NASA Hazardous Waste Storage Yard

The Area II Hazardous Waste Storage Yard is currently the 90-day storage facility for NASA hazardous waste at the Santa Susana Site. All hazardous waste is stored inside or in approved containers, and is transported offsite for disposal. The storage yard

SSFL Best Management Practices Plan

NPDES Permit No. CA0001309

Page 4

contains awnings for covered storage. The storage yard is adjacent to the storage propellant area (SPA) facility in Area II.

Best Management Practices in Place:

Significant materials are either stored inside or outside in approved storage cabinets or secondary containment. The building is inspected on a monthly basis.

AREA III

Area III: Outfall 018 Stormwater Treatment System (SWTS) – Silvernale Pond

The Outfall 018 SWTS is a high-performing treatment system that treats stormwater from its surrounding watershed and stormwater that is conveyed from Outfalls 003, 004, 005, 006, 007, 010, 012, 013 and R-2A/R-2B ponds prior to discharge as discussed in Section 3.5. Chemicals used in the treatment process are aluminum sulfate, anionic polymer, hydrochloric acid, sodium hydroxide and potassium permanganate.

Best Management Practices in Place:

Significant materials are either stored in approved storage cabinets or secondary containment. The building is inspected on a monthly basis.

AREA IV

Building 4021 Radioactive Material Handling Facility (RMHF)

The building is currently inactive and was used for the packaging and shipping of radioactive waste. Currently the chemicals stored in the area are Cesium-137, P-10 gas, propane, synthetic lubricants, waste aerosols, and waste oils. The area is completely bermed. All activities are conducted indoors under tightly controlled conditions.

Best Management Practices in Place:

Significant materials are either stored in approved storage cabinets or secondary containment. The building is inspected on a monthly basis.

Area IV: Department of Energy (DOE) Hazardous Waste Storage Yard

The Area IV Hazardous Waste Storage Yard is currently the 90-day storage location for DOE hazardous waste. All hazardous waste is stored inside or in approved containers, and is transported off Site for disposal. The hazardous waste yard is a storage area adjacent to Building 4038 in Area IV.

Best Management Practices in Place:

Significant materials are either stored in approved storage cabinets or secondary containment. The building is inspected on a monthly basis.

IV. NON-STRUCTURAL BMP's AND PROGRAM ADMINISTRATION

The general administration of this and other BMP programs in place at the Santa Susana Site involve the implementation of company-wide pollution control policies, procedures, and employee training programs intended to ensure environmental quality and pollution control at all Santa Susana Site-operated facilities. These "non-structural" management practices are an integral part of the Santa Susana Site commitment to

SSFL Best Management Practices Plan

NPDES Permit No. CA0001309

Page 5

environmental quality and are as important to the administration and effectiveness of the program as site-specific source control BMPs. These documents establish a framework for implementation of the BMP program as they set forth employee and departmental responsibilities, operating procedures, and employee training requirements.

Inspections of bermed areas in active portions of the Site are routinely conducted by both area personnel and Santa Susana Site Environmental Health and Safety (EHS) personnel. Should a problem be noted on the inspection form, corrective actions taken to mitigate the problem will also be noted on the inspection form.

The Santa Susana Site is well equipped to respond to unintentional releases of hazardous materials. The Site has a fire department which is staffed 24 hours a day, as well as a number of employees trained as first responders for incidents involving chemical releases. Should a significant incident occur, the notification procedures for Environmental Regulatory Agencies found in the Santa Susana Site Spill Prevention and Response Plan (Appendix E of the SWPPP) would be followed.

V. BMPs

Boeing has implemented structural and non-structural BMPs at the regulated outfalls at the Site in order to comply with NPDES permit effluent concentration limits. The BMPs at the outfalls are summarized in the table below. A more detailed description of the structural BMP(s) at each outfall is provided following the table. Figures B-1 through B-3 provide additional details on Site BMPs, specifically the Silvernale Pond Conveyance System (aka Site Wide Conveyance System), and Outfall 011 and 018 Storm Water Treatment Systems.

Outfall BMP Summary

Outfall	BMPs Implemented
001	Sediment and erosion control BMPs
002	Sediment and erosion control BMPs
003	BMP consists of a containment area with an overflow from the containment area to a sand filter bed, then through a mixed media filter bed (containing, sand, granular activated carbon and zeolite), and finally discharge to the outfall; a pump is also provided to convey runoff to the Outfall 018 SWTS
004	BMP consists of a containment area with an overflow from the containment area to a sand filter bed, then through a mixed media filter bed (containing, sand, granular activated carbon and zeolite) and finally discharge to the outfall; a pump is also provided to convey runoff to the Outfall 018 SWTS
005	BMP consists of a containment area with an overflow from the containment area to the outfall; a pump is also provided to convey runoff to the Outfall 018 SWTS
006	BMP consists of a containment area with an overflow from the containment area to a sand filter bed, then through a mixed media filter bed (containing, sand, granular activated carbon and

SSFL Best Management Practices Plan**NPDES Permit No. CA0001309**

Page 6

Outfall	BMPs Implemented
	zeolite), and finally discharge to the outfall; a pump is also provided to convey runoff to the Outfall 018 SWTS
007	BMP consists of a containment area with an overflow from the containment area to the outfall; a pump is also provided to convey runoff to the Outfall SWTS
008*	Sediment and erosion control BMPs
009*	Sediment and erosion control BMPs
010	BMP consists of a containment area with an overflow from the containment area to a sand filter bed and then discharge to the outfall; a pump is also provided to convey runoff to the Outfall 018 SWTS
011	BMP consists of a containment area with an overflow through a granular activated carbon media and a stormwater treatment system (physical filtration and chemical treatment) that treats runoff and discharges to the outfall, including stormwater from Outfall 014
012	BMP consists of a containment area with an overflow from the containment area over a series of bags that contained mixed filter media, and then discharge to the outfall; a pump is also provided to convey runoff to the Outfall 018 SWTS
013	BMP consists of a containment area with an overflow from the containment area over a series of bags that contained mixed filter media, and then discharge to the outfall; a pump is also provided to convey runoff to the Outfall 018 treatment system
014	BMP consists of a bermed retention pond with natural planting with an overflow from the retention pond to the outfall. The stormwater overflow from this area is pumped and conveyed to the Outfall 011 SWTS.
018	BMP consists of a containment area with an overflow through a granular activated carbon media and zeolite and a stormwater treatment system (physical filtration and chemical treatment) that treats runoff from the individual outfall (018) and runoff collected via the Site stormwater conveyance system, and discharges to the outfall
019	Building 1449-GETS consists of a bag filters, metals removal (ion exchange and/or sand filters), air stripping, granular activated carbon, advanced oxidation (AOP) and finally discharge through a conveyance system at Outfall 019

SSFL Best Management Practices Plan

NPDES Permit No. CA0001309

Page 7

Outfall 003

Structural BMP consists of a dual-media bed gravity flow filtration system built into existing natural features of the outfall area. The media beds consist of one upstream sand filtration bed, and one downstream granular activated carbon (GAC) and zeolite bed. Further upstream before the sand filtration bed is an impoundment created by a natural depression and a downstream gabion dam. The gabion dam has a flow-through discharge pipe for water to pass through the dam to the filtration system. A conveyance pump is also provided to convey storm water runoff from the outfall watershed to the Outfall 018 storm water treatment system for further treatment prior to discharge. Run off that is conveyed to Outfall 018 for treatment is discharged at Outfall 018.

Outfall 004

Structural BMP consists of a dual-media bed gravity flow filtration system built into existing natural features of the outfall area. The media beds consist of one upstream sand filtration bed, and one downstream granular activated carbon (GAC) and zeolite bed. A conveyance pump is also provided to convey storm water runoff from the outfall watershed to the Outfall 018 storm water treatment system for further treatment prior to discharge. Run off that is conveyed to Outfall 018 for treatment is discharged at Outfall 018.

Outfall 006

Structural BMP consists of a dual-media bed gravity flow filtration system built into existing natural features of the outfall area. The media beds consist of one upstream sand filtration bed, and one downstream granular activated carbon (GAC) and zeolite bed. A conveyance pump is also provided to convey storm water runoff from the outfall watershed to the Outfall 018 storm water treatment system for further treatment prior to discharge. Run off that is conveyed to Outfall 018 for treatment is discharged at Outfall 018.

Outfall 010

Structural BMP consists of a single media bed gravity flow filtration basin built into existing natural features of the outfall area. The media beds consist of one layer of sand, one layer of granular activated carbon (GAC), and one layer of zeolite. A conveyance pump is also provided to convey storm water runoff from the outfall watershed to the Outfall 018 storm water treatment system for further treatment prior to discharge. Run off that is conveyed to Outfall 018 for treatment is discharged at Outfall 018.

Outfall 011

Structural BMP consists of a stormwater treatment system and a single media bed gravity flow filtration system built into existing natural features of the outfall area. The stormwater treatment system is described further below. The media beds consist of bulk granular activated carbon (GAC) media.

Outfall 018

Structural BMP consists of a stormwater treatment system and multi-cell gravity flow filtration system built into an existing concrete spillway downstream of the outfall ponds. The stormwater treatment system is described further below. The filtration cells consist of bulk GAC and zeolite media.

VI. PROPOSED BMP's AND IMPLEMENTATION SCHEDULE

Adequate control technology is in place through both structural and non-structural BMP's to essentially achieve the objective of this program on a consistent basis. Site inspections provide a means for identifying opportunities to improve some BMP controls in place at specific sites. Planned BMP improvements that have been implemented are listed and described below.

Outfalls 011/018 SWTSs (Perimeter Pond and Silvernale Pond, respectively). Boeing has constructed high-performing treatment systems to treat stormwater from outfall watersheds prior to its discharge. Stormwater from Outfalls 003, 004, 005, 006, 007, 010, 012, 013, and R-2A/R-2B ponds will be conveyed to the Outfall 018 SWTS for treatment; stormwater from Outfall 014 will be conveyed to the Outfall 011 SWTS for treatment. Because of the size of these watersheds, the extraordinarily low effluent limits, and the advanced technology required for treatment, developing such a system required pilot testing which occurred through 2008 to 2010.

Based on the final results of the pilot tests, selected filter media and processes were included in the final treatment system to improve water quality discharges from within the context of the iterative BMP process. This system consists of a clean water treatment system and a solids handling and disposal system. The clean water treatment system pumps stormwater from ponds through screen filters, oxidation contact tanks, an ACTIFLO unit, two banks of sand filters, bag filters, and GAC media filters. The ACTIFLO unit controls high turbidity peaks and protects the rest of the system from solids overload. The fraction of solids that remains in suspension are removed by filtration through two stages of sand filters followed by bag filters. The finished effluent is then polished through a bank of GAC media filters before being discharged at approximately 1,000 gallons per minute (gpm) to Outfall 018. Outfall 011 SWTS utilizes the same treatment technologies but has a treatment capacity of 700 gpm.

The solids handling and disposal system removes all solids produced by the clean water treatment system. The solids generated by ACTIFLO is sent to a lamella plate settler for further thickening. The solids generated from sand filter backwashing is collected in a backwash tank and then pumped to open top weir tanks for further thickening. The thickened solids are pumped to a mixer tank which provides a homogenous solids stream to the dewatering unit. The solids produced from the dewatering unit is collected and transported offsite for disposal. The supernatant and filtrate produced in the thickening and dewatering processes are collected in a supernatant tank and then returned to the front of the system to be re-treated. Figure B-2 and B-3 show the layouts of Outfalls 011 and 018.

SSFL Best Management Practices Plan

NPDES Permit No. CA0001309

Page 9

Outfall 019 – The GETS treats extracted groundwater from Areas I, II, III, and IV of the Santa Susana Site. The GETS consists of a bank of bag filters, metals removal, air stripping, liquid and vapor phase GAC, advanced oxidation process (AOP - based on UV light and hydrogen peroxide) and finally discharge of treated water through a conveyance system and dissipater located just south of Outfall 001. Additionally, calcium chloride may be added to effluent prior to discharge if hardness concentrations warrant the addition. The metals removal is accomplished through one of two treatment trains. The first option would consist of particulate filtration utilizing bag filters, oxidation possibly with chlorine or permanganate, followed by ion exchange resin. The secondary option consists of particulate filtration utilizing bag filters followed by ion exchange resin. Specific ion exchange resins are used to treat iron, manganese and zinc. Effluent from the last ion exchange vessel may be treated with air stripping, GAC and AOP, or a combination thereof. Treated effluent water is monitored within Building 1449 and discharged through a conveyance system and a flow dissipater, consisting of 12" rip rap at Outfall 019 located south of Outfall 001. Figure B-4 provides a process flow diagram for the GETS.

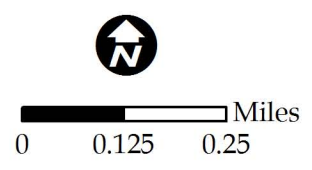
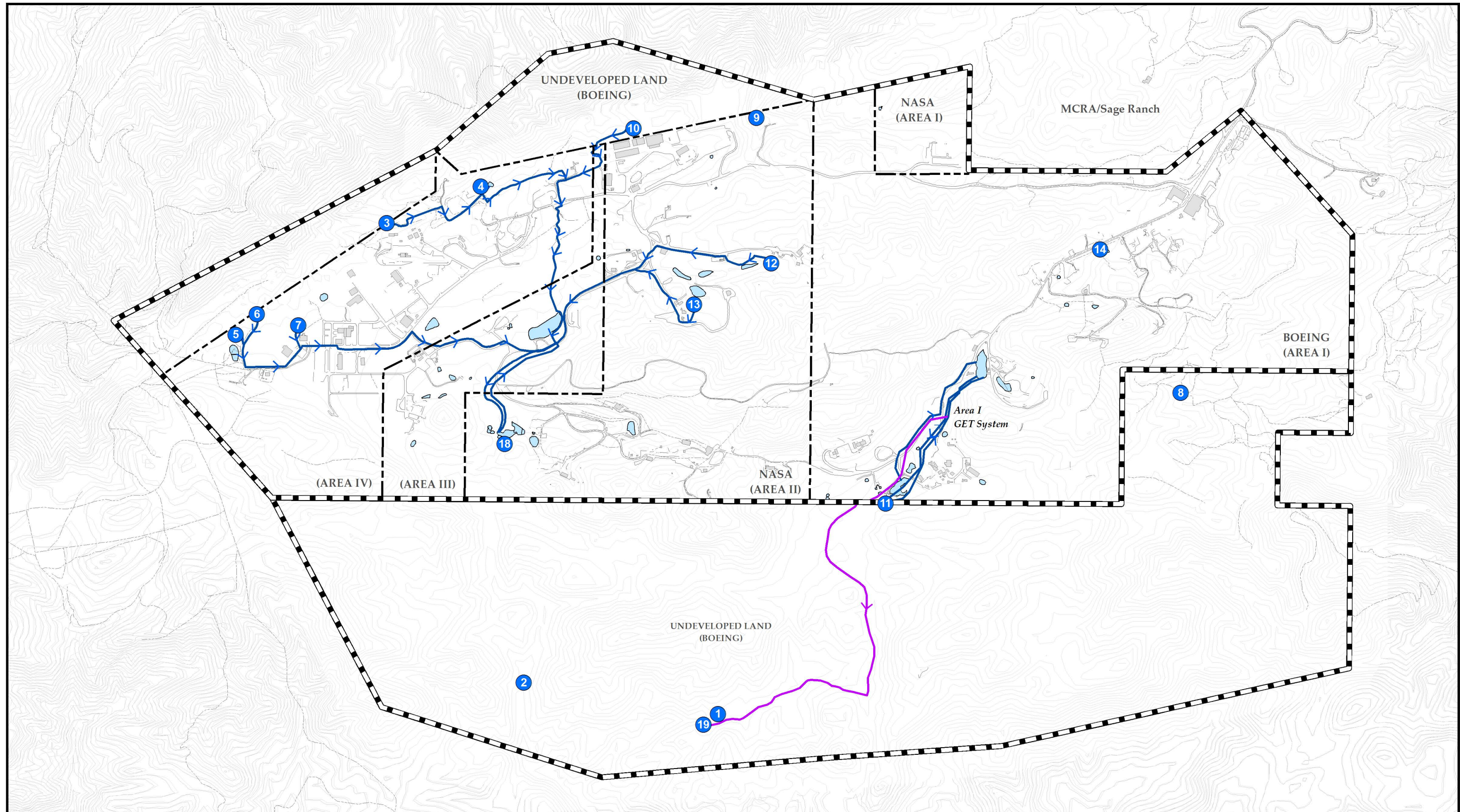

Base Map Legend

- Stormwater Conveyance Pipeline with Flow Direction
- GETS Discharge Conveyance Pipeline
- Roads
- Dirt Road
- Pond
- Administrative Area Boundary
- NPDES Outfall
- Existing Buildings
- Elevation Contour

Site Wide Conveyance System

Date: September 26, 2011
 File: \\UspsInetapp1\dei\rocketdyne_gis\MasterGISFiles\ISRA_Projects\ISRA_MXD\BMP\CompliancePlanSept2010\FigC1_SiteWideConveyance.mxd



FIGURE B-1

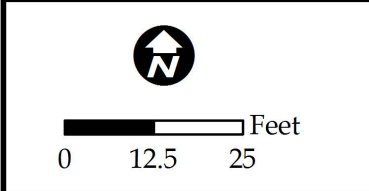
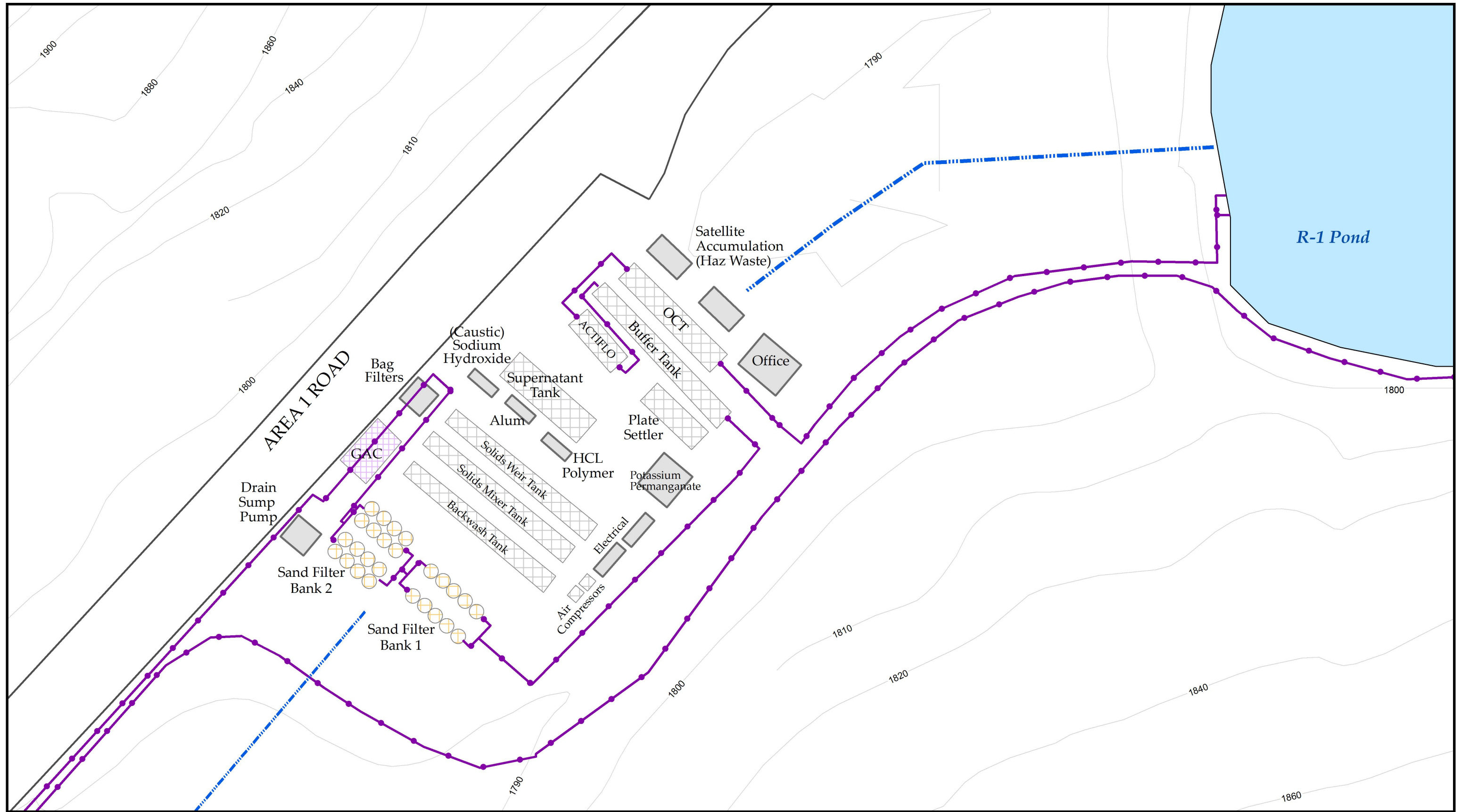

Base Map Legend

- Roads
- Surface Water Drainage



Pond

Stormwater Treatment System Infrastructure

- Pipe Corridor



Tank

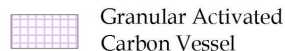

Granular Activated Carbon Vessel

- Building or Structure



Sand Filter

Outfall 11 Stormwater Treatment System

Date: October 24, 2012
 File: \\Usas1s01\dei\rocketdyne gis\Master GISFiles\ISRA_Projects\ISRA_MX\BMP\Compliance PlanSept2010\FigC2_OF11_BMP_Updated.mxd



FIGURE B-2

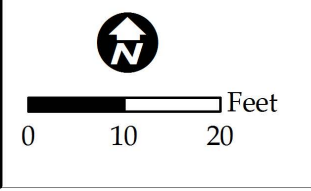
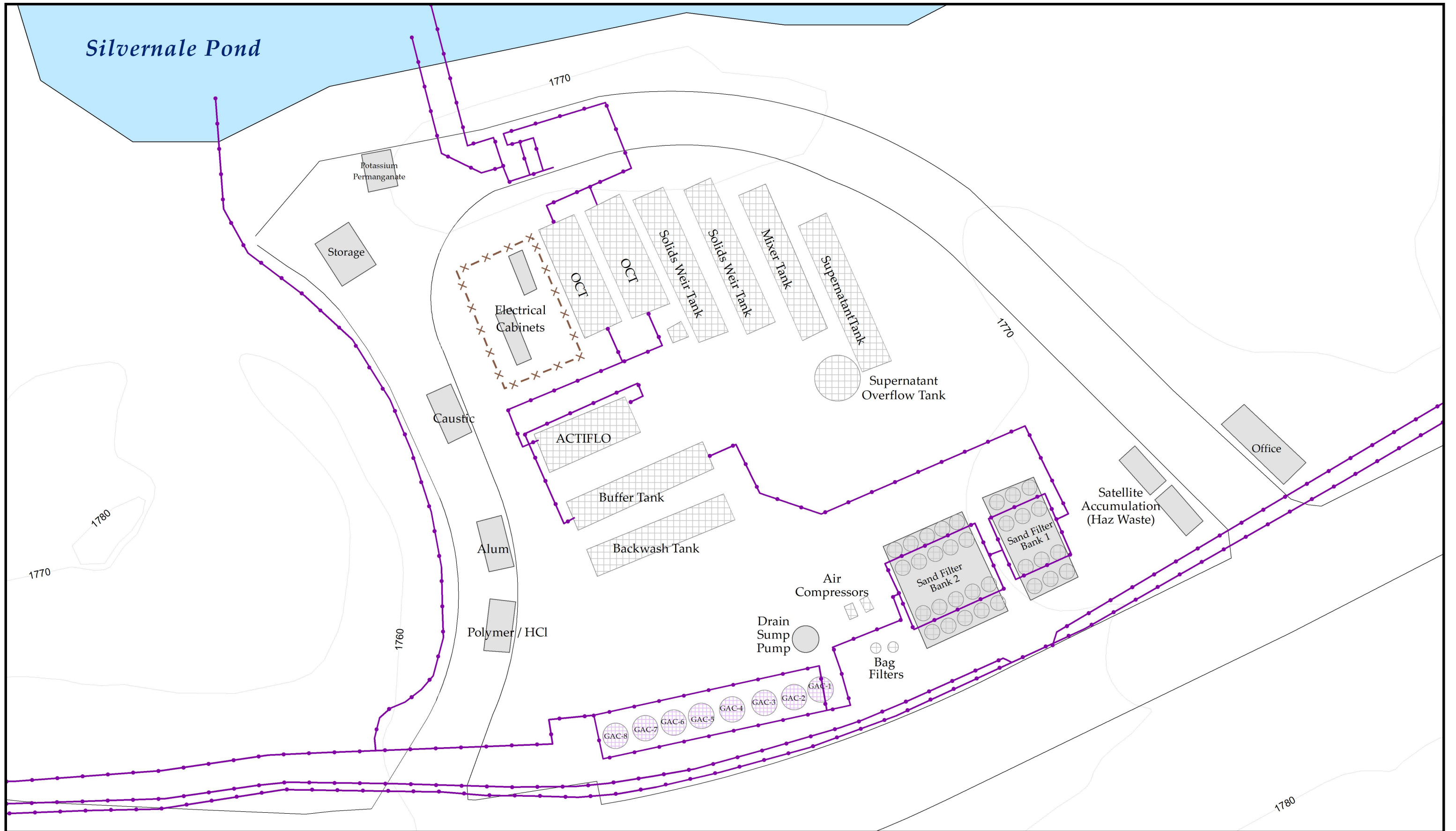

Base Map Legend		Stormwater Treatment System Infrastructure	
	Roads		Pipe Corridor
	Pond		Fence
			Tank
			Building or Structure

Outfall 18 Stormwater Treatment System

Date: October 22, 2012
 File: \\Uspsas01\dei\rocketdyne gis\MasterGISFiles\ISRA_Projects\ISRA_MX\BMP\CompliancePlanSept2010\FigC3_OF18_BMP_Update.mxd

MWH

FIGURE B-3

Sep 21, 2011 - 10:51am ADE - T:\2011\1000-1099\10xx SSFL\GET\Presentation\810-2567.dwg

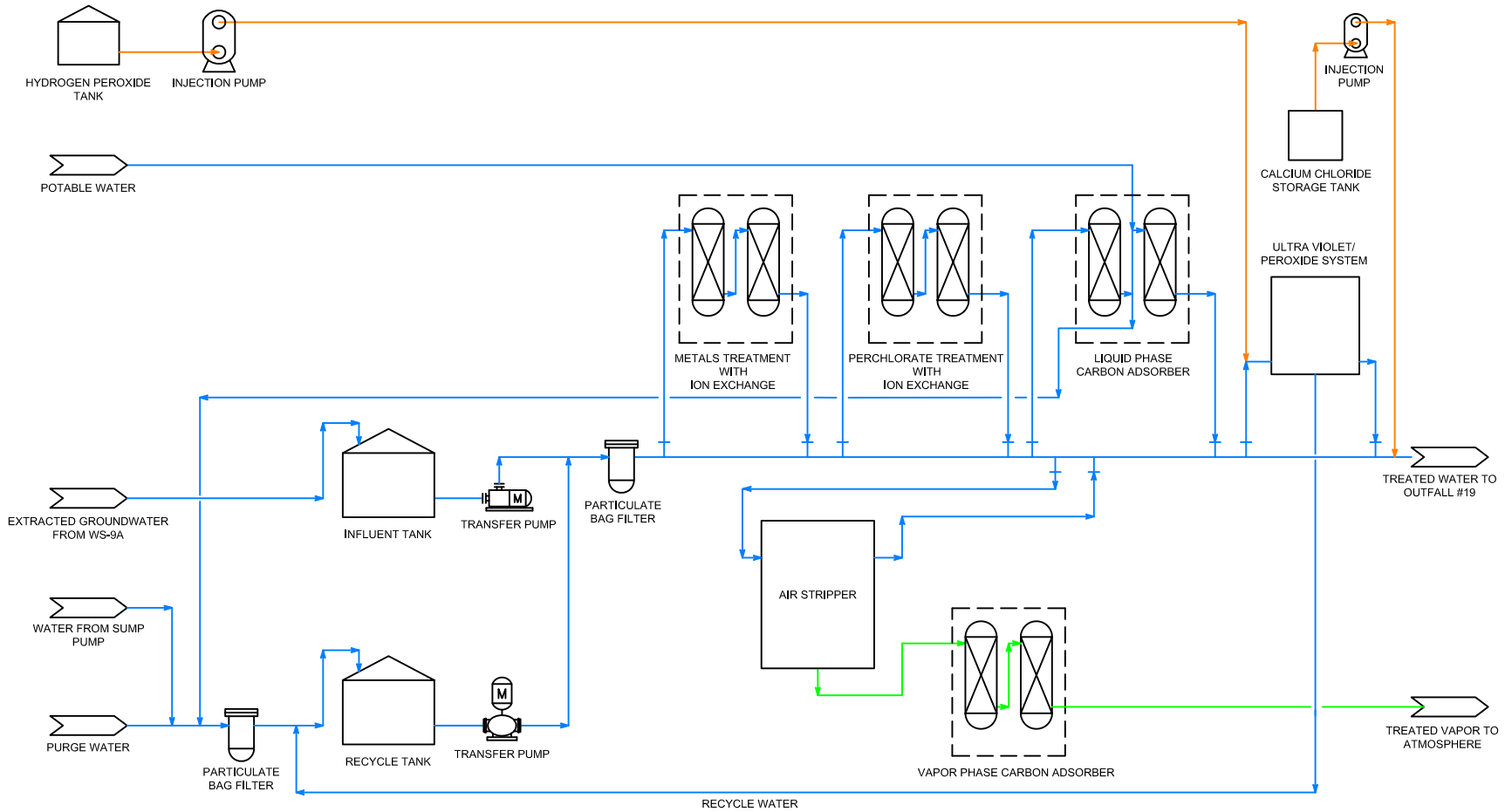

EXPLANATION	
—	WATER LINE
—	VAPOR LINE
—	CHEMICAL LINE



HARGIS+ASSOCIATES, INC.
Hydrogeology/Engineering

FIGURE B-4
GROUNDWATER EXTRACTION & TREATMENT SYSTEM
PROCESS FLOW

APPENDIX C

Significant Materials Inventory

**March 2012 Hazardous Materials Inventory Summary
The Boeing Company - Santa Susana Field Laboratory**

Number	Unit	Area	Facility	Material Name	Max. Amt. Stored	Avg. Daily Amount	Largest Container	Amt. Ann'l Waste
Area 1 Fire Station UP0001222 Map Grid - D35								
HZ0013123	(Unit #39)	Area 1	Fire Station	ABC	400	400	400 lbs	
HZ0013124	(Unit #39)	Area 1	Fire Station	Ansulite ARC (Foam)	620	620	55 gal	
HZ0011788	(Unit #39)	Area 1	Fire Station	Oxygen Gas	60	60	15 ft3	
Area 1 Bldg 1407 HWSA UP0001211 Map Grid - D28								
HZ0011803	(Unit #26)	Area 1	Bldg 1407 HWSA	Soil, Equip, and Debris Contaminated w/ PCB	10,000	200	5,000 lbs	10,000
HZ0004963	(Unit #26)	Area 1	Bldg 1407 HWSA	Waste Mercury and Mercury Containing Mfg. Articles	50	10	50 lbs	100
HZ0011801	(Unit #26)	Area 1	Bldg 1407 HWSA	Waste Oil and Oil/Water	1,200	200	1,200 lbs	2,000
HZ0011804	(Unit #26)	Area 1	Bldg 1407 HWSA	Waste Paint	350	10	55 gal	350
HZ0005064	(Unit #26)	Area 1	Bldg 1407 HWSA	Potassium Permanganate	3000	100	55 lbs	3000
Need HZ Number	(Unit #26)	Area 1	Bldg 1407 HWSA	PRESSURIZED GASES	100	1	300 ft3	100
HZ0006057	(Unit #26)	Area 1	Bldg 1407 HWSA	Sodium Hydroxide 25% Solution	1,210	1,210	55 gal	
HZ0003382	(Unit #26)	Area 1	Bldg 1407 HWSA	Lab Pack Waste - Toxic Solids	60	25	60 lbs	120

Number	Unit	Area	Facility	Material Name	Max. Amt. Stored	Avg. Daily Amount	Largest Container	Amt. Ann'l Waste
HZ0004974	(Unit #26)	Area 1	Bldg 1407 HWSA	Soil and Debris (incl. concrete) Contaminated w/ Metals	500,000	80,000	40,000 lbs	1,000,000
HZ0003345	(Unit #26)	Area 1	Bldg 1407 HWSA	Waste Oil Filled Equip and Components	2,000	500	2,000 lbs	5,000
HZ0003405	(Unit #26)	Area 1	Bldg 1407 HWSA	Soil, Filter Media, and Debris (incl. concrete) Contaminated w/ Solvents	300,000	10,000	40,000 lbs	500,000
Need HZ Number	(Unit #26)	Area 1	Bldg 1407 HWSA	SOLVENTS	162	1	14 gal	162
Need HZ Number	(Unit #26)	Area 1	Bldg 1407 HWSA	TOXIC SUBSTANCES AND DEBRIS	5000	20	5000 lbs	8000
Need HZ Number	(Unit #26)	Area 1	Bldg 1407 HWSA	WASTE WATER CONTAMINATED W/ METALS	150	5	55 gal	150
HZ0003308	(Unit #26)	Area 1	Bldg 1407 HWSA	Waste Water Contaminated w/ Spent Solvents	40000	1000	40,000 lbs	45,000
HZ0011810	(Unit #26)	Area 1	Bldg 1407 HWSA	Soil and Debris Contaminated w/ Petroleum	10,000	2,000	10,000 lbs	10,000
HZ0011815	(Unit #26)	Area 1	Bldg 1407 HWSA	Waste Acids and Acidic Solutions	50	50	50 lbs	50
Need HZ Number	(Unit #26)	Area 1	Bldg 1407 HWSA	Propane	460	460	20 gal	
HZ0003301	(Unit #26)	Area 1	Bldg 1407 HWSA	Waste Friable Asbestos and Debris	6,500	500	1,000 lbs	6,500
Need HZ Number	(Unit #26)	Area 1	Bldg 1407 HWSA	OXIDIZERS AND OXIDIZER CONTAMINATED DEBRIS	100	<1	100 lbs	100
HZ0004975	(Unit #26)	Area 1	Bldg 1407 HWSA	Hydrochloric Acid 14.5% Solution	1100	770	55 gal	
HZ0008545	(Unit #26)	Area 1	Bldg 1407 HWSA	Lab Pack Waste - Toxic Liquids	500	200	75 lbs	500
HZ0003307	(Unit #26)	Area 1	Bldg 1407 HWSA	Waste Aerosols	100	40	40 lbs	100
Need HZ Number	(Unit #26)	Area 1	Bldg 1407 HWSA	ALCOHOL FILLED COMPONENTS	75	<1	55 gal	75

Number	Unit	Area	Facility	Material Name	Max. Amt. Stored	Avg. Daily Amount	Largest Container	Amt. Ann'l Waste
HZ0003351	(Unit #26)	Area 1	Bldg 1407 HWSA	Waste Alkaline Solutions	500	100	500 lbs	1000
HZ0003340	(Unit #26)	Area 1	Bldg 1407 HWSA	Lab Pack Waste - Flammable Liquids	50	20	50 lbs	200
HZ0011806	(Unit #26)	Area 1	Bldg 1407 HWSA	Waste Antifreeze	258	258	258 lbs	258
HZ0011794	(Unit #26)	Area 1	Bldg 1407 HWSA	Waste Caustic Contaminated Debris	200	20	60 lbs	200
HZ0003380	(Unit #26)	Area 1	Bldg 1407 HWSA	Empty Containers	80	80	80 lbs	80
HZ0004971	(Unit #26)	Area 1	Bldg 1407 HWSA	Hydrex 3751 Copolymer	800	110	55 gal	800
HZ0003309	(Unit #26)	Area 1	Bldg 1407 HWSA	Lab Pack Waste - Corrosive Liquids	320	20	55 gal	600
HZ0004965	(Unit #26)	Area 1	Bldg 1407 HWSA	Waste Acid Contaminated Debris	500	55	55 lbs	500
HZ0013134	(Unit #26)	Area 1	Bldg 1407 HWSA	Aluminum Sulfate Solution (Alum)	1,540	1,540	55 gal	
Area 1	Core Hole		UP0001211				Map Grid - D34	
HZ0020205	(Unit #26)	Area 1	Core Hole	Nitrogen Gas	300	300	300 ft3	
Area 1	Bldg 1408 Contractor Staging Area		UP0001223				Map Grid - D35	
HZ0013134	(Unit #40)	Area 1	Bldg 1408 Contractor Staging Area	Diesel Fuel	120	120	74 gal	
HZ0019635	(Unit #40)	Area 1	Bldg 1408 Contractor Staging Area	Nitrogen Gas	3600	3600	300 ft3	
HZ0003383	(Unit #40)	Area 1	Bldg 1408 Contractor Staging Area	Paint (Various)	100	55	5 gal	
Need HZ Number	(Unit #40)	Area 1	Bldg 1408 Contractor Staging Area	UNLEADED GASOLINE	150	100	20 gal	

Number	Unit	Area	Facility	Material Name	Max. Amt. Stored	Avg. Daily Amount	Largest Container	Amt. Ann'l Waste
--------	------	------	----------	---------------	------------------	-------------------	-------------------	------------------

Area 1 Bldg 1324 Staging Area UP0001202

Map Grid - D27/33

HZ0003374 (Unit #21) Area 1 Bldg 1324 Staging Area Unleaded Gasoline 500 300 500 gal

Area 1 OF 11 SWTS UP0001227

Map Grid - J21/K15

HZ0003379 (Unit #44) Area 1 OF 11 SWTS Hydrex 3751 Copolymer 55 30 25 gal

HZ0003381 (Unit #44) Area 1 OF 11 SWTS Hydrochloric Acid 14.5% Solution 220 110 200 gal 80

HZ0004973 (Unit #44) Area 1 OF 11 SWTS Waste Acid Debris 300 150 300 lbs 300

HZ0003369 (Unit #44) Area 1 OF 11 SWTS Aluminum Sulfate 50% Solution (Alum) 330 165 350 gal 30

HZ0003389 (Unit #44) Area 1 OF 11 SWTS Potassium Permanganate 55 30 350 gal 360

HZ0022642 (Unit #44) Area 1 OF 11 SWTS Potassium Permanganate 220 110 55 lbs

HZ0004972 (Unit #44) Area 1 OF 11 SWTS Sodium Hydroxide 25% Solution 220 110 350 gal 20

HZ0005063 (Unit #44) Area 1 OF 11 SWTS Waste Caustic Debris 300 150 300 lbs 300

Area 1 GETS UP0001228

Map Grid - J28

HZ0003300 (Unit #45) Area 1 GETS Ion Exchange Resin 6,000 6,000 3,000 lbs 30,000

HZ0005061 (Unit #45) Area 1 GETS Waste Water Contaminated w/ Spent Solvents 45,000 17,000 38,000 lbs 240,000

HZ0022820 (Unit #45) Area 1 GETS Waste Caustic Debris 25 5 25 lbs 50

Need HZ Number (Unit #45) Area 1 GETS BIRM FILTER MEDIA 6,000 6,000 3,000 6,000

HZ0022818 (Unit #45) Area 1 GETS Activated Carbon 8,000 8,000 2,000 lbs 9,000

Number	Unit	Area	Facility	Material Name	Max. Amt. Stored	Avg. Daily Amount	Largest Container	Amt. Ann'l Waste
HZ0022819	(Unit #45)	Area 1	GETS	Waste Acid Contaminated Debris	25	5	25 lbs	50
HZ0022821	(Unit #45)	Area 1	GETS	Waste Water W/ Alkaline Reagents	120	5	120 lbs	260
Area 1 Well 14			UP00001201	Map Grid - D27				
HZ0005143	(Unit #17)	Area 1	Well 14	Nitrogen Gas	300	300	300 ft3	
Area 2 COCA			UP00000095	Map Grid - H34/35				
Need HZ Number	(Unit #2)	Area 2	COCA	Argon Gas	200	125	200 ft3	
HZ0008558	(Unit #2)	Area 2	COCA	Helium Gas	53,119 ft3	53,119	52,519 ft3	
HZ0003302	(Unit #2)	Area 2	COCA	Nitrogen Gas	103,581	103,581	57,025 ft3	
Area 2 Skyline			UP00001225	Map Grid - J17				
HZ0016234	(Unit #42)	Area 2	Skyline	Diesel Fuel	1,000	1,000	1,000 gal	
HZ0003304	(Unit #42)	Area 2	Skyline	Propane	1,000	1,000	500 gal	
Area 2 HWSA SPA			UP00001224	Map Grid - B40				
HZ0003348	(Unit #41)	Area 2	HWSA SPA	Soil and Debris (incl. concrete) Contaminated w/ Metals	280	5	1 yd3	280
HZ0003366	(Unit #41)	Area 2	HWSA SPA	Waste Oil Contaminated Debris	1,500	5	1 yd3	1,500
Need HZ Number	(Unit #41)	Area 2	HWSA SPA	WASTE WATER CONTAMINATED W/ METALS	70	1	30 gal	70
Need HZ Number	(Unit #41)	Area 2	HWSA SPA	OIL FILLED EQUIPMENT AND COMPONENTS	55	1	55 gal	55
Need HZ Number	(Unit #41)	Area 2	HWSA SPA	MERCURY & MERCURY CONTAINING MFG ARTICLES	5	5	5 gal	5

Number	Unit	Area	Facility	Material Name	Max. Amt. Stored	Avg. Daily Amount	Largest Container	Amt. Ann'l Waste
HZ0019639	(Unit #41)	Area 2	HWSA SPA	Waste Oil and Oil/Water	850	3	30 gal	850
Area 3 Silvernale SWTS UP0001229				Map Grid - H3/4				
HZ0022828	(Unit #46)	Area 3	Silvernale SWTS	Waste Acid Debris	31	1	30 gal	31
HZ0022826	(Unit #46)	Area 3	Silvernale SWTS	Hydrochloric Acid 14.5% Solution	910	455	55 gal	1
HZ0022644	(Unit #46)	Area 3	Silvernale SWTS	Aluminum Sulfate 50% Solution (Alum)	1,540	770	55 gal	1
HZ0003377	(Unit #46)	Area 3	Silvernale SWTS	Hydrex 3751 Copolymer	110	55	55 gal	
HZ0011811	(Unit #46)	Area 3	Silvernale SWTS	Sodium Hydroxide 25% Solution	1210	605 gal	55 gal	1
HZ0022822	(Unit #46)	Area 3	Silvernale SWTS	Potassium Permanganate	1,000	500	55 lbs	90
Need HZ Number	(Unit #46)	Area 3	Silvernale SWTS	PAINT	160	80	5 gal	
Area 3 Praxair LN2 Unit UP0001209				Map Grid - H5				
HZ0013137	(Unit #23)	Area 3	Praxair LN2 Unit	Nitrogen, Liquid	6,000	6,000	6,000 gal	
Area 4 Bldg 100 UP0001233				Map Grid - G10				
HZ0003358	(Unit #50)	Area 4	Bldg 100	Tritium Containing Items	40	40	40 lbs	
Need HZ Number	(Unit #50)	Area 4	Bldg 100	Nitrogen, Liquid	80	80	80 gal	
HZ0005066	(Unit #50)	Area 4	Bldg 100	Americium Containing Items	9	9	9 lbs	
HZ0005065	(Unit #50)	Area 4	Bldg 100	Argon and Methane Gas Mixture (P-10 Gas)	900	900	300 ft3	
Area 4 HWSA Bldg 4011 UP0001648				Map Grid - G13				

Number	Unit	Area	Facility	Material Name	Max. Amt. Stored	Avg. Daily Amount	Largest Container	Amt. Ann'l Waste
Need HZ Number	(Unit #64)	Area 4	HWSA Bldg 4011	MERCURY & MERCURY CONTAINING MFG ARTICLES	5	5	5 gal	5
HZ0019033	(Unit #64)	Area 4	HWSA Bldg 4011	Waste Oil and Oil/Water	11	11	5 gal	11
HZ0005118	(Unit #64)	Area 4	HWSA Bldg 4011	Waste Water Contaminated w/ Spent Solvents	60,000	60,000	18,000 gal	60,000
Area 4 Bldg 019				Map Grid - A40				
HZ0005116	(Unit #38)	Area 4	Bldg 019	Elemental Lead	30,000	30,000	5,000 lbs	
Area 4 RMHF				Map Grid - A34				
HZ0007746	(Unit #47)	Area 4	RMHF	Propane	50	50	50 gal	
HZ0010453	(Unit #47)	Area 4	RMHF	Diocetyl Sebacate (Uniflex DOS)	880	880	440 lbs	
HZ0003352	(Unit #47)	Area 4	RMHF	Elemental Lead	5,000	5,000	2,000 lbs	
HZ0007745	(Unit #47)	Area 4	RMHF	Low Level Radioactive Waste	7,744	7,744	3,800 lbs	7,744
HZ0007611	(Unit #47)	Area 4	RMHF	P-10 Gas (Argon/Methane 90/10)	600	600	300 ft3	
HZ0007740	(Unit #47)	Area 4	RMHF	Potential Mixed Waste Debris	100	10	55 gal	100

APPENDIX D

California Storm Water Handbook Best Management Practices Factsheets

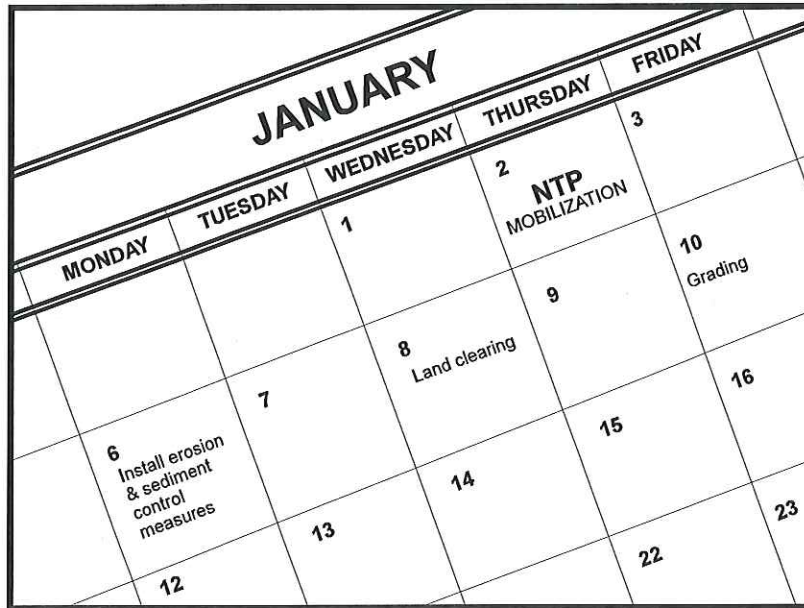

Description and Purpose

Scheduling is the development of a written plan that includes sequencing of construction activities and the implementation of BMPs such as erosion control and sediment control while taking local climate (rainfall, wind, etc.) into consideration. The purpose is to reduce the amount and duration of soil exposed to erosion by wind, rain, runoff, and vehicle tracking, and to perform the construction activities and control practices in accordance with the planned schedule.

Suitable Applications

Proper sequencing of construction activities to reduce erosion potential should be incorporated into the schedule of every construction project especially during rainy season. Use of other, more costly yet less effective, erosion and sediment control BMPs may often be reduced through proper construction sequencing.

Limitations

- Environmental constraints such as nesting season prohibitions reduce the full capabilities of this BMP.

Implementation

- Avoid rainy periods. Schedule major grading operations during dry months when practical. Allow enough time before rainfall begins to stabilize the soil with vegetation or physical means or to install sediment trapping devices.
- Plan the project and develop a schedule showing each phase

Categories

EC	Erosion Control	<input checked="" type="checkbox"/>
SE	Sediment Control	<input checked="" type="checkbox"/>
TC	Tracking Control	<input checked="" type="checkbox"/>
WE	Wind Erosion Control	<input checked="" type="checkbox"/>
NS	Non-Stormwater Management Control	
WM	Waste Management and Materials Pollution Control	

Legend:

- Primary Objective
- Secondary Objective

Targeted Constituents

Sediment	<input checked="" type="checkbox"/>
Nutrients	
Trash	
Metals	
Bacteria	
Oil and Grease	
Organics	

Potential Alternatives

None



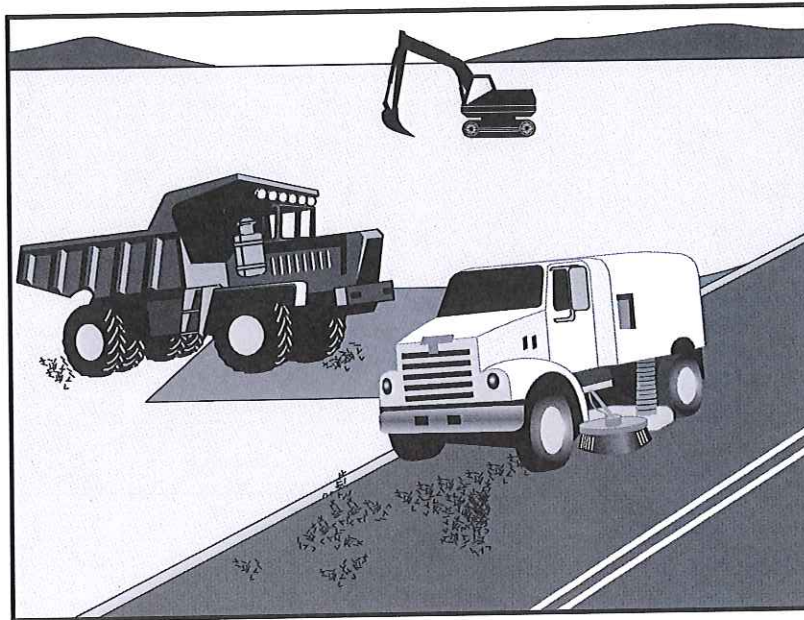

Description and Purpose

Street sweeping and vacuuming includes use of self-propelled and walk-behind equipment to remove sediment from streets and roadways, and to clean paved surfaces in preparation for final paving. Sweeping and vacuuming prevents sediment from the project site from entering storm drains or receiving waters.

Suitable Applications

Sweeping and vacuuming are suitable anywhere sediment is tracked from the project site onto public or private paved streets and roads, typically at points of egress. Sweeping and vacuuming are also applicable during preparation of paved surfaces for final paving.

Limitations

Sweeping and vacuuming may not be effective when sediment is wet or when tracked soil is caked (caked soil may need to be scraped loose).

Implementation

- Controlling the number of points where vehicles can leave the site will allow sweeping and vacuuming efforts to be focused, and perhaps save money.
- Inspect potential sediment tracking locations daily.
- Visible sediment tracking should be swept or vacuumed on a daily basis.
- Do not use kick brooms or sweeper attachments. These tend to spread the dirt rather than remove it.

Categories

EC	Erosion Control	
SE	Sediment Control	<input checked="" type="checkbox"/>
TC	Tracking Control	<input checked="" type="checkbox"/>
WE	Wind Erosion Control	
NS	Non-Stormwater Management Control	
WM	Waste Management and Materials Pollution Control	

Legend:

- Primary Objective
- Secondary Objective

Targeted Constituents

Sediment	<input checked="" type="checkbox"/>
Nutrients	
Trash	<input checked="" type="checkbox"/>
Metals	
Bacteria	
Oil and Grease	<input checked="" type="checkbox"/>
Organics	

Potential Alternatives

None



- If not mixed with debris or trash, consider incorporating the removed sediment back into the project

Costs

Rental rates for self-propelled sweepers vary depending on hopper size and duration of rental. Expect rental rates from \$58/hour (3 yd³ hopper) to \$88/hour (9 yd³ hopper), plus operator costs. Hourly production rates vary with the amount of area to be swept and amount of sediment. Match the hopper size to the area and expect sediment load to minimize time spent dumping.

Inspection and Maintenance

- Inspect BMPs prior to forecast rain, daily during extended rain events, after rain events, weekly during the rainy season, and at two-week intervals during the non-rainy season.
- When actively in use, points of ingress and egress must be inspected daily.
- When tracked or spilled sediment is observed outside the construction limits, it must be removed at least daily. More frequent removal, even continuous removal, may be required in some jurisdictions.
- Be careful not to sweep up any unknown substance or any object that may be potentially hazardous.
- Adjust brooms frequently; maximize efficiency of sweeping operations.
- After sweeping is finished, properly dispose of sweeper wastes at an approved dumpsite.

References

Stormwater Quality Handbooks - Construction Site Best Management Practices (BMPs) Manual, State of California Department of Transportation (Caltrans), November 2000.

Labor Surcharge and Equipment Rental Rates, State of California Department of Transportation (Caltrans), April 1, 2002 – March 31, 2003.

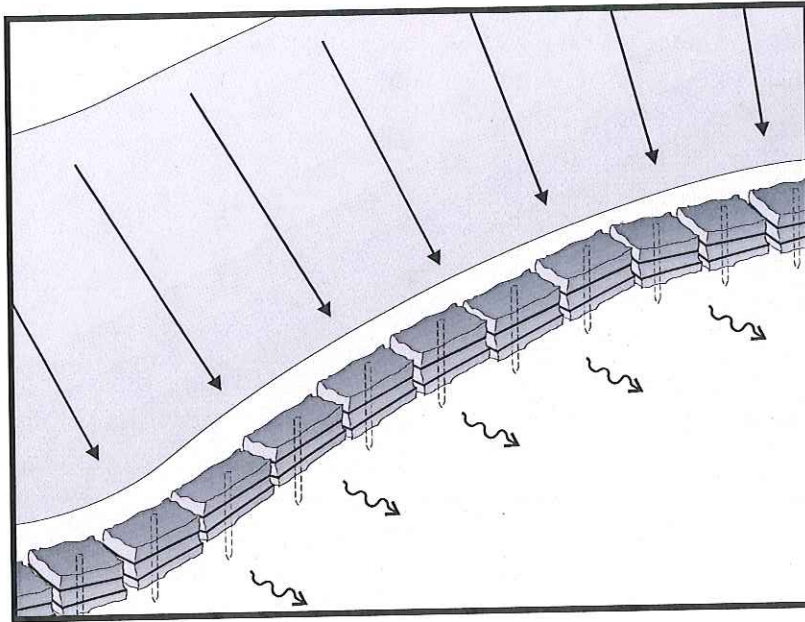

Description and Purpose

A straw bale barrier is a series of straw bales placed on a level contour to intercept sheet flows. Straw bale barriers pond sheet-flow runoff, allowing sediment to settle out.

Suitable Applications

Straw bale barriers may be suitable:

- As a linear sediment control measure:
 - Below the toe of slopes and erodible slopes
 - As sediment traps at culvert/pipe outlets
 - Below other small cleared areas
 - Along the perimeter of a site
 - Down slope of exposed soil areas
 - Around temporary stockpiles and spoil areas
 - Parallel to a roadway to keep sediment off paved areas
 - Along streams and channels
- As linear erosion control measure:
 - Along the face and at grade breaks of exposed and erodible slopes to shorten slope length and spread runoff as sheet flow

Categories

EC	Erosion Control	<input checked="" type="checkbox"/>
SE	Sediment Control	<input checked="" type="checkbox"/>
TC	Tracking Control	
WE	Wind Erosion Control	
NS	Non-Stormwater Management Control	
WM	Waste Management and Materials Pollution Control	

Legend:

- Primary Objective
- Secondary Objective

Targeted Constituents

Sediment	<input checked="" type="checkbox"/>
Nutrients	
Trash	
Metals	
Bacteria	
Oil and Grease	
Organics	

Potential Alternatives

- SE-1 Silt Fence
- SE-5 Fiber Rolls
- SE-6 Gravel Bag Berm
- SE-8 Sandbag Barrier



- At the top of slopes to divert runoff away from disturbed slopes
- As check dams across mildly sloped construction roads

Limitations

Straw bale barriers:

- Are not to be used for extended periods of time because they tend to rot and fall apart
- Are suitable only for sheet flow on slopes of 10 % or flatter
- Are not appropriate for large drainage areas, limit to one acre or less
- May require constant maintenance due to rotting
- Are not recommended for concentrated flow, inlet protection, channel flow, and live streams
- Cannot be made of bale bindings of jute or cotton
- Require labor-intensive installation and maintenance
- Cannot be used on paved surfaces
- Should not to be used for drain inlet protection
- Should not be used on lined ditches
- May introduce undesirable non-native plants to the area

Implementation

General

A straw bale barrier consists of a row of straw bales placed on a level contour. When appropriately placed, a straw bale barrier intercepts and slows sheet flow runoff, causing temporary ponding. The temporary ponding provides quiescent conditions allowing sediment to settle. Straw bale barriers also interrupt the slope length and thereby reduce erosion by reducing the tendency of sheet flows to concentrate into rivulets, which erode rills, and ultimately gullies, into disturbed, sloped soils.

Straw bale barriers have not been as effective as expected due to improper use. These barriers have been placed in streams and drainage ways where runoff volumes and velocities have caused the barriers to wash out. In addition, failure to stake and entrench the straw bale has allowed undercutting and end flow. Use of straw bale barriers in accordance with this BMP should produce acceptable results.

Design and Layout

- Locate straw bale barriers on a level contour.
 - Slopes up to 10:1 (H:V): Straw bales should be placed at a maximum interval of 50 ft (a closer spacing is more effective), with the first row near the toe of slope.
 - Slopes greater than 10:1 (H:V): Not recommended.

- Turn the ends of the straw bale barrier up slope to prevent runoff from going around the barrier.
- Allow sufficient space up slope from the barrier to allow ponding, and to provide room for sediment storage.
- For installation near the toe of the slope, consider moving the barrier away from the slope toe to facilitate cleaning. To prevent flow behind the barrier, sand bags can be placed perpendicular to the barrier to serve as cross barriers.
- Drainage area should not exceed 1 acre, or 0.25 acre per 100 ft of barrier.
- Maximum flow path to the barrier should be limited to 100 ft.
- Straw bale barriers should consist of two parallel rows.
 - Butt ends of bales tightly
 - Stagger butt joints between front and back row
 - Each row of bales must be trenched in and firmly staked
- Straw bale barriers are limited in height to one bale laid on its side.
- Anchor bales with either two wood stakes or four bars driven through the bale and into the soil. Drive the first stake towards the butt joint with the adjacent bale to force the bales together.
- See attached figure for installation details.

Materials

- **Straw Bale Size:** Each straw bale should be a minimum of 14 in. wide, 18 in. in height, 36 in. in length and should have a minimum mass of 50 lbs. The straw bale should be composed entirely of vegetative matter, except for the binding material.
- **Bale Bindings:** Bales should be bound by steel wire, nylon or polypropylene string placed horizontally. Jute and cotton binding should not be used. Baling wire should be a minimum diameter of 14 gauge. Nylon or polypropylene string should be approximately 12 gauge in diameter with a breaking strength of 80 lbs force.
- **Stakes:** Wood stakes should be commercial quality lumber of the size and shape shown on the plans. Each stake should be free from decay, splits or cracks longer than the thickness of the stake, or other defects that would weaken the stakes and cause the stakes to be structurally unsuitable. Steel bar reinforcement should be equal to a #4 designation or greater. End protection should be provided for any exposed bar reinforcement.

Costs

Straw bales cost \$5 - \$7 each. Adequate labor should be budgeted for installation and maintenance.

Inspection and Maintenance

Maintenance

- Inspect BMPs prior to forecast rain, daily during extended rain events, after rain events, weekly during the rainy season, and at two-week intervals during the non-rainy season.
- Straw bales degrade, especially when exposed to moisture. Rotting bales will need to be replaced on a regular basis.
- Replace or repair damaged bales as needed.
- Repair washouts or other damages as needed.
- Sediment that accumulates in the BMP must be periodically removed in order to maintain BMP effectiveness. Sediment should be removed when the sediment accumulation reaches one-third of the barrier height. Sediment removed during maintenance may be incorporated into earthwork on the site or disposed at an appropriate location.
- Remove straw bales when no longer needed. Remove sediment accumulation, and clean, re-grade, and stabilize the area. Removed sediment should be incorporated in the project or disposed of.

References

Stormwater Quality Handbooks - Construction Site Best Management Practices (BMPs) Manual, State of California Department of Transportation (Caltrans), November 2000.

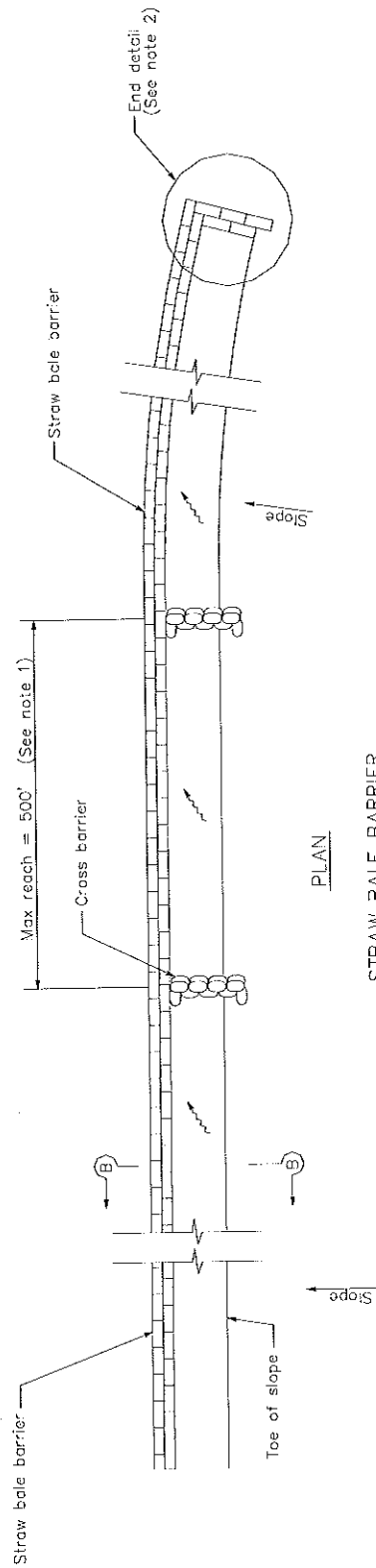

STRAW BALE BARRIER

LEGEND
DIRECTION OF FLOW

NOTES

1. Construct the length of each reach so that the change in base elevation along the reach does not exceed 1/2 the height of the linear barrier. In no case shall the reach length exceed 500'.
2. The end of barrier shall be turned up slope.
3. Dimension may vary to fit field condition.
4. Stake dimensions are nominal.
5. Place straw bales tightly together.
6. Temp embedment spoils against sides of installed bales.
7. Drive angled wood stake before vertical stake to ensure tight abutment to adjacent bale.
8. Sandbag cross barriers should be a min of 1/2 and a max of 2/3 the height of the linear barrier.
9. Sandbag rows and layers should be offset to eliminate gaps.

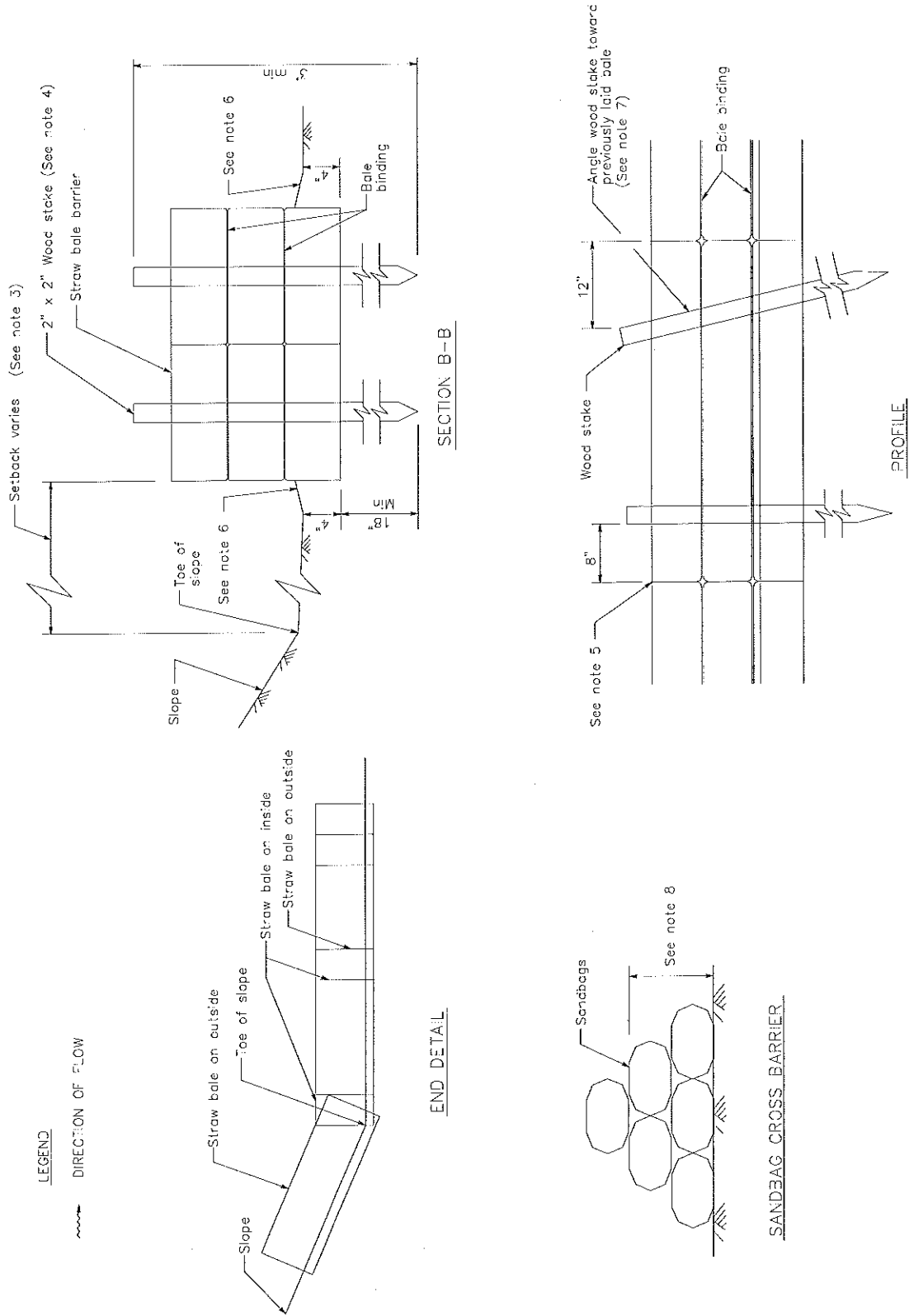

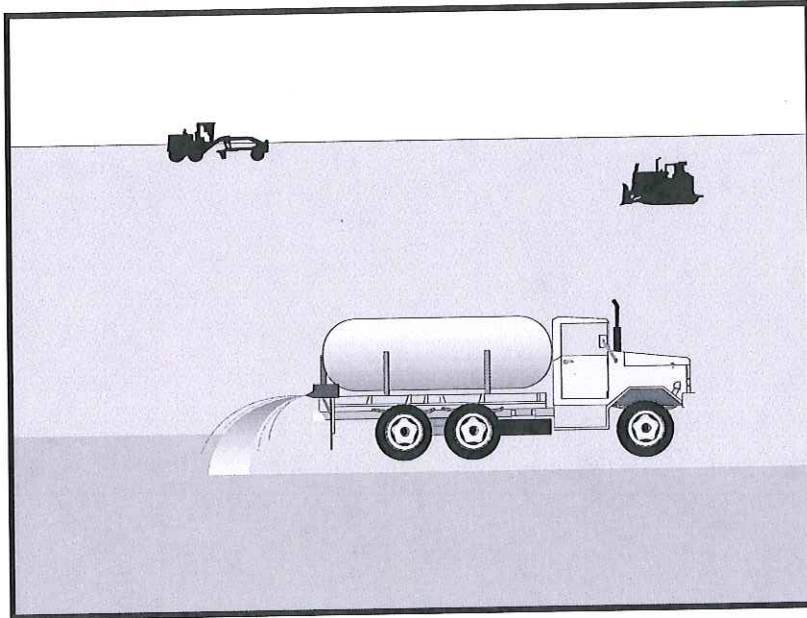

Categories

EC	Erosion Control	
SE	Sediment Control	<input checked="" type="checkbox"/>
TC	Tracking Control	
WE	Wind Erosion Control	<input checked="" type="checkbox"/>
NS	Non-Stormwater Management Control	
WM	Waste Management and Materials Pollution Control	

Legend:

- Primary Category
- Secondary Category

Targeted Constituents

Sediment	<input checked="" type="checkbox"/>
Nutrients	
Trash	
Metals	
Bacteria	
Oil and Grease	
Organics	

Potential Alternatives

EC-5 Soil Binders

Description and Purpose

Wind erosion or dust control consists of applying water or other chemical dust suppressants as necessary to prevent or alleviate dust nuisance generated by construction activities. Covering small stockpiles or areas is an alternative to applying water or other dust palliatives.

California's Mediterranean climate, with a short "wet" season and a typically long, hot "dry" season, allows the soils to thoroughly dry out. During the dry season, construction activities are at their peak, and disturbed and exposed areas are increasingly subject to wind erosion, sediment tracking and dust generated by construction equipment. Site conditions and climate can make dust control more of an erosion problem than water based erosion. Additionally, many local agencies, including Air Quality Management Districts, require dust control and/or dust control permits in order to comply with local nuisance laws, opacity laws (visibility impairment) and the requirements of the Clean Air Act. Wind erosion control is required to be implemented at all construction sites greater than 1 acre by the General Permit.

Suitable Applications

Most BMPs that provide protection against water-based erosion will also protect against wind-based erosion and dust control requirements required by other agencies will generally meet wind erosion control requirements for water quality protection. Wind erosion control BMPs are suitable during the following construction activities:



- Construction vehicle traffic on unpaved roads
- Drilling and blasting activities
- Soils and debris storage piles
- Batch drop from front-end loaders
- Areas with unstabilized soil
- Final grading/site stabilization

Limitations

- Watering prevents dust only for a short period (generally less than a few hours) and should be applied daily (or more often) to be effective.
- Over watering may cause erosion and track-out.
- Oil or oil-treated subgrade should not be used for dust control because the oil may migrate into drainageways and/or seep into the soil.
- Chemical dust suppression agents may have potential environmental impacts. Selected chemical dust control agents should be environmentally benign.
- Effectiveness of controls depends on soil, temperature, humidity, wind velocity and traffic.
- Chemical dust suppression agents should not be used within 100 feet of wetlands or water bodies.
- Chemically treated subgrades may make the soil water repellent, interfering with long-term infiltration and the vegetation/re-vegetation of the site. Some chemical dust suppressants may be subject to freezing and may contain solvents and should be handled properly.
- In compacted areas, watering and other liquid dust control measures may wash sediment or other constituents into the drainage system.
- If the soil surface has minimal natural moisture, the affected area may need to be pre-wetted so that chemical dust control agents can uniformly penetrate the soil surface.

Implementation

Dust Control Practices

Dust control BMPs generally stabilize exposed surfaces and minimize activities that suspend or track dust particles. The following table presents dust control practices that can be applied to varying site conditions that could potentially cause dust. For heavily traveled and disturbed areas, wet suppression (watering), chemical dust suppression, gravel asphalt surfacing, temporary gravel construction entrances, equipment wash-out areas, and haul truck covers can be employed as dust control applications. Permanent or temporary vegetation and mulching can be employed for areas of occasional or no construction traffic. Preventive measures include minimizing surface areas to be disturbed, limiting onsite vehicle traffic to 15 mph or less, and controlling the number and activity of vehicles on a site at any given time.

Chemical dust suppressants include: mulch and fiber based dust palliatives (e.g. paper mulch with gypsum binder), salts and brines (e.g. calcium chloride, magnesium chloride), non-petroleum based organics (e.g. vegetable oil, lignosulfonate), petroleum based organics (e.g. asphalt emulsion, dust oils, petroleum resins), synthetic polymers (e.g. polyvinyl acetate, vinyls, acrylic), clay additives (e.g. bentonite, montmorillonite) and electrochemical products (e.g. enzymes, ionic products).

Site Condition	Dust Control Practices							
	Permanent Vegetation	Mulching	Wet Suppression (Watering)	Chemical Dust Suppression	Gravel or Asphalt	Temporary Gravel Construction Entrances/Equipment Wash Down	Synthetic Covers	Minimize Extent of Disturbed Area
Disturbed Areas not Subject to Traffic	X	X	X	X	X			X
Disturbed Areas Subject to Traffic			X	X	X	X		X
Material Stockpiles		X	X	X			X	X
Demolition			X			X	X	
Clearing/Excavation			X	X				X
Truck Traffic on Unpaved Roads			X	X	X	X	X	
Tracking					X	X		

Additional preventive measures include:

- Schedule construction activities to minimize exposed area (see EC-1, Scheduling).
- Quickly treat exposed soils using water, mulching, chemical dust suppressants, or stone/gravel layering.
- Identify and stabilize key access points prior to commencement of construction.
- Minimize the impact of dust by anticipating the direction of prevailing winds.
- Restrict construction traffic to stabilized roadways within the project site, as practicable.
- Water should be applied by means of pressure-type distributors or pipelines equipped with a spray system or hoses and nozzles that will ensure even distribution.
- All distribution equipment should be equipped with a positive means of shutoff.
- Unless water is applied by means of pipelines, at least one mobile unit should be available at all times to apply water or dust palliative to the project.
- If reclaimed waste water is used, the sources and discharge must meet California Department of Health Services water reclamation criteria and the Regional Water Quality

Control Board (RWQCB) requirements. Non-potable water should not be conveyed in tanks or drain pipes that will be used to convey potable water and there should be no connection between potable and non-potable supplies. Non-potable tanks, pipes, and other conveyances should be marked, "NON-POTABLE WATER - DO NOT DRINK."

- Pave or chemically stabilize access points where unpaved traffic surfaces adjoin paved roads.
- Provide covers for haul trucks transporting materials that contribute to dust.
- Provide for rapid clean up of sediments deposited on paved roads. Furnish stabilized construction road entrances and wheel wash areas.
- Stabilize inactive areas of construction sites using temporary vegetation or chemical stabilization methods.

For chemical stabilization, there are many products available for chemically stabilizing gravel roadways and stockpiles. If chemical stabilization is used, the chemicals should not create any adverse effects on stormwater, plant life, or groundwater and should meet all applicable regulatory requirements.

Costs

Installation costs for water and chemical dust suppression vary based on the method used and the length of effectiveness. Annual costs may be high since some of these measures are effective for only a few hours to a few days.

Inspection and Maintenance

- Inspect and verify that activity-based BMPs are in place prior to the commencement of associated activities.
- BMPs must be inspected in accordance with General Permit requirements for the associated project type and risk level. It is recommended that at a minimum, BMPs be inspected weekly, prior to forecasted rain events, daily during extended rain events, and after the conclusion of rain events.
- Check areas protected to ensure coverage.
- Most water-based dust control measures require frequent application, often daily or even multiple times per day. Obtain vendor or independent information on longevity of chemical dust suppressants.

References

Best Management Practices and Erosion Control Manual for Construction Sites, Flood Control District of Maricopa County, Arizona, September 1992.

California Air Pollution Control Laws, California Air Resources Board, updated annually.

Construction Manual, Chapter 4, Section 10, "Dust Control"; Section 17, "Watering"; and Section 18, "Dust Palliative", California Department of Transportation (Caltrans), July 2001.

Prospects for Attaining the State Ambient Air Quality Standards for Suspended Particulate Matter (PM₁₀), Visibility Reducing Particles, Sulfates, Lead, and Hydrogen Sulfide, California Air Resources Board, April 1991.

Stormwater Quality Handbooks Construction Site Best Management Practices (BMPs) Manual, State of California Department of Transportation (Caltrans), March 2003.

Stabilized Construction Entrance/Exit TC-1

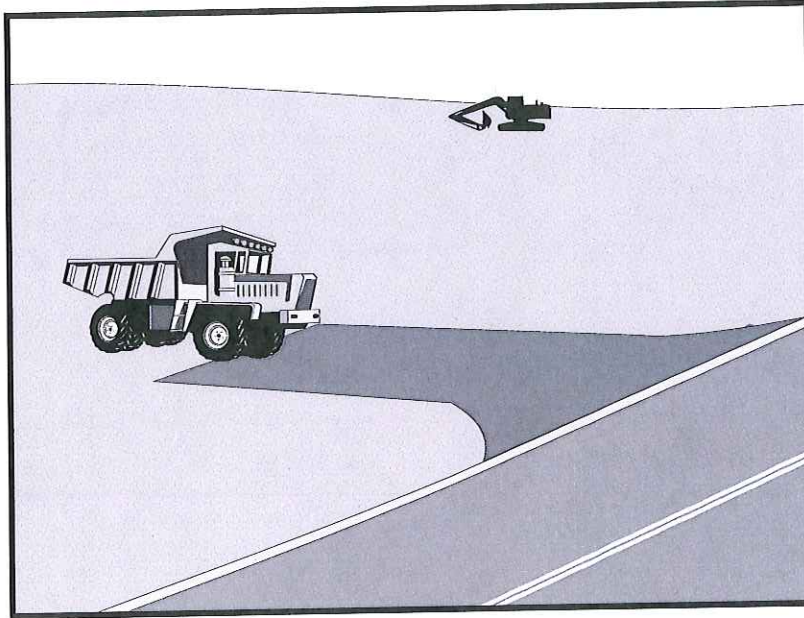

Description and Purpose

A stabilized construction access is defined by a point of entrance/exit to a construction site that is stabilized to reduce the tracking of mud and dirt onto public roads by construction vehicles.

Suitable Applications

Use at construction sites:

- Where dirt or mud can be tracked onto public roads.
- Adjacent to water bodies.
- Where poor soils are encountered.
- Where dust is a problem during dry weather conditions.

Limitations

- Entrances and exits require periodic top dressing with additional stones.
- This BMP should be used in conjunction with street sweeping on adjacent public right of way.
- Entrances and exits should be constructed on level ground only.
- Stabilized construction entrances are rather expensive to construct and when a wash rack is included, a sediment trap of some kind must also be provided to collect wash water

Categories

EC	Erosion Control	<input checked="" type="checkbox"/>
SE	Sediment Control	<input checked="" type="checkbox"/>
TC	Tracking Control	<input checked="" type="checkbox"/>
WE	Wind Erosion Control	
NS	Non-Stormwater Management Control	
WM	Waste Management and Materials Pollution Control	

Legend:

- Primary Objective
- Secondary Objective

Targeted Constituents

Sediment	<input checked="" type="checkbox"/>
Nutrients	
Trash	
Metals	
Bacteria	
Oil and Grease	
Organics	

Potential Alternatives

None



Stabilized Construction Entrance/Exit TC-1

runoff.

Implementation

General

A stabilized construction entrance is a pad of aggregate underlain with filter cloth located at any point where traffic will be entering or leaving a construction site to or from a public right of way, street, alley, sidewalk, or parking area. The purpose of a stabilized construction entrance is to reduce or eliminate the tracking of sediment onto public rights of way or streets. Reducing tracking of sediments and other pollutants onto paved roads helps prevent deposition of sediments into local storm drains and production of airborne dust.

Where traffic will be entering or leaving the construction site, a stabilized construction entrance should be used. NPDES permits require that appropriate measures be implemented to prevent tracking of sediments onto paved roadways, where a significant source of sediments is derived from mud and dirt carried out from unpaved roads and construction sites.

Stabilized construction entrances are moderately effective in removing sediment from equipment leaving a construction site. The entrance should be built on level ground. Advantages of the Stabilized Construction Entrance/Exit is that it does remove some sediment from equipment and serves to channel construction traffic in and out of the site at specified locations. Efficiency is greatly increased when a washing rack is included as part of a stabilized construction entrance/exit.

Design and Layout

- Construct on level ground where possible.
- Select 3 to 6 in. diameter stones.
- Use minimum depth of stones of 12 in. or as recommended by soils engineer.
- Construct length of 50 ft minimum, and 30 ft minimum width.
- Rumble racks constructed of steel panels with ridges and installed in the stabilized entrance/exit will help remove additional sediment and to keep adjacent streets clean.
- Provide ample turning radii as part of the entrance.
- Limit the points of entrance/exit to the construction site.
- Limit speed of vehicles to control dust.
- Properly grade each construction entrance/exit to prevent runoff from leaving the construction site.
- Route runoff from stabilized entrances/exits through a sediment trapping device before discharge.
- Design stabilized entrance/exit to support heaviest vehicles and equipment that will use it.

Stabilized Construction Entrance/Exit TC-1

- Select construction access stabilization (aggregate, asphaltic concrete, concrete) based on longevity, required performance, and site conditions. Do not use asphalt concrete (AC) grindings for stabilized construction access/roadway.
- If aggregate is selected, place crushed aggregate over geotextile fabric to at least 12 in. depth, or place aggregate to a depth recommended by a geotechnical engineer. A crushed aggregate greater than 3 in. but smaller than 6 in. should be used.
- Designate combination or single purpose entrances and exits to the construction site.
- Require that all employees, subcontractors, and suppliers utilize the stabilized construction access.
- Implement SE-7, Street Sweeping and Vacuuming, as needed.
- All exit locations intended to be used for more than a two-week period should have stabilized construction entrance/exit BMPs.

Inspection and Maintenance

- Inspect and verify that activity-based BMPs are in place prior to the commencement of associated activities. While activities associated with the BMPs are under way, inspect weekly during the rainy season and of two-week intervals in the non-rainy season to verify continued BMP implementation.
- Inspect local roads adjacent to the site daily. Sweep or vacuum to remove visible accumulated sediment.
- Remove aggregate, separate and dispose of sediment if construction entrance/exit is clogged with sediment.
- Keep all temporary roadway ditches clear.
- Check for damage and repair as needed.
- Replace gravel material when surface voids are visible.
- Remove all sediment deposited on paved roadways within 24 hours.
- Remove gravel and filter fabric at completion of construction

Costs

Average annual cost for installation and maintenance may vary from \$1,200 to \$4,800 each, averaging \$2,400 per entrance. Costs will increase with addition of washing rack, and sediment trap. With wash rack, costs range from \$1,200 - \$6,000 each, averaging \$3,600 per entrance.

References

Manual of Standards of Erosion and Sediment Control Measures, Association of Bay Area Governments, May 1995.

Stabilized Construction Entrance/Exit TC-1

National Management Measures to Control Nonpoint Source Pollution from Urban Areas, USEPA Agency, 2002.

Proposed Guidance Specifying Management Measures for Sources of Nonpoint Pollution in Coastal Waters, Work Group Working Paper, USEPA, April 1992.

Stormwater Quality Handbooks Construction Site Best Management Practices (BMPs) Manual, State of California Department of Transportation (Caltrans), November 2000.

Stormwater Management of the Puget Sound Basin, Technical Manual, Publication #91-75, Washington State Department of Ecology, February 1992.

Virginia Erosion and Sedimentation Control Handbook, Virginia Department of Conservation and Recreation, Division of Soil and Water Conservation, 1991.

Guidance Specifying Management Measures for Nonpoint Pollution in Coastal Waters, EPA 840-B-9-002, USEPA, Office of Water, Washington, DC, 1993.

Water Quality Management Plan for the Lake Tahoe Region, Volume II, Handbook of Management Practices, Tahoe Regional Planning Agency, November 1988.

Stabilized Construction Entrance/Exit TC-1

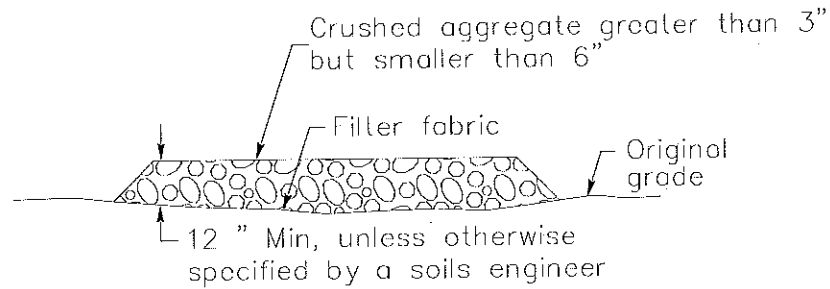

SECTION B-B
NTS

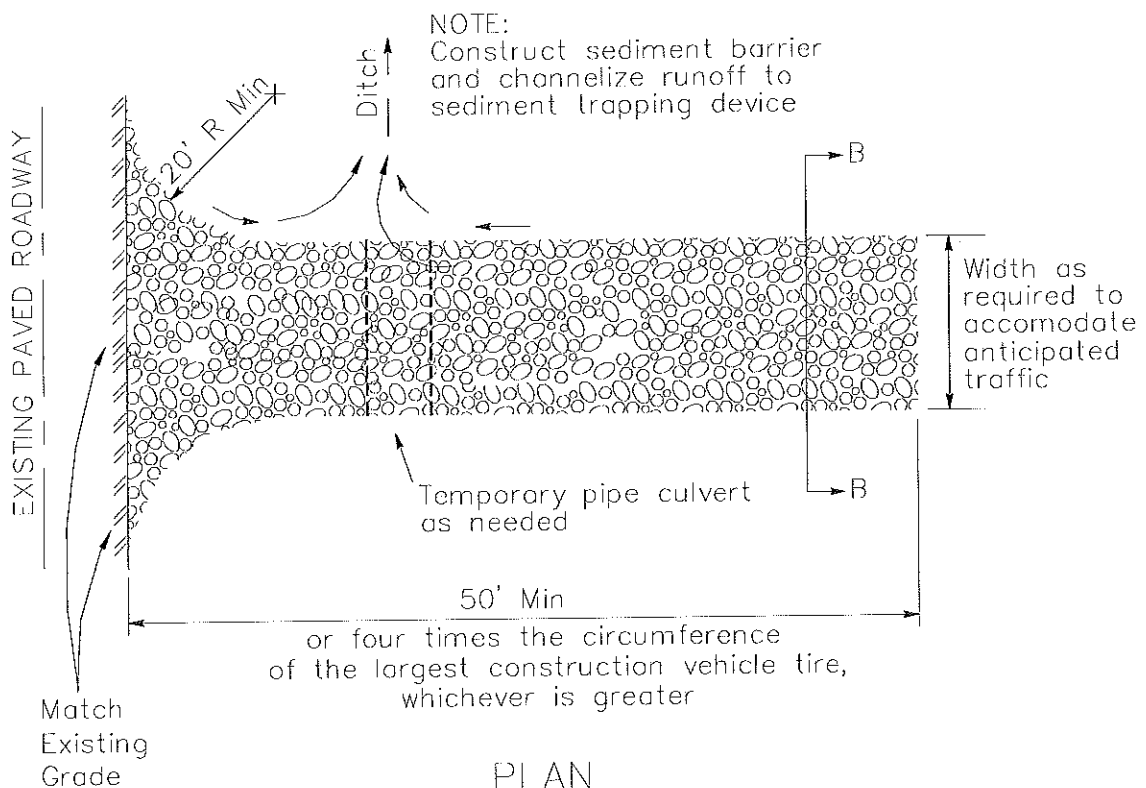

PLAN
NTS

Stabilized Construction Entrance/Exit TC-1

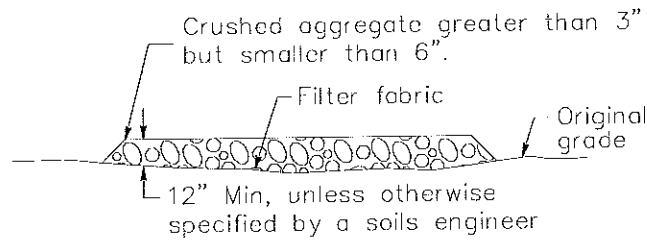

SECTION B-B
NTS

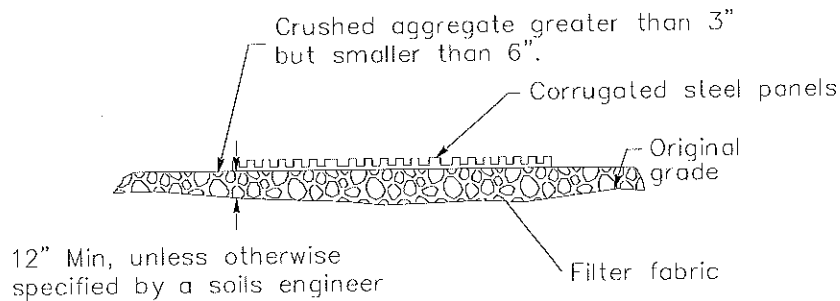

SECTION A-A
NOT TO SCALE

NOTE:
Construct sediment barrier and channelize runoff to sediment trapping device

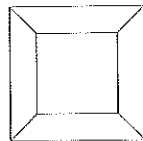

Sediment trapping device

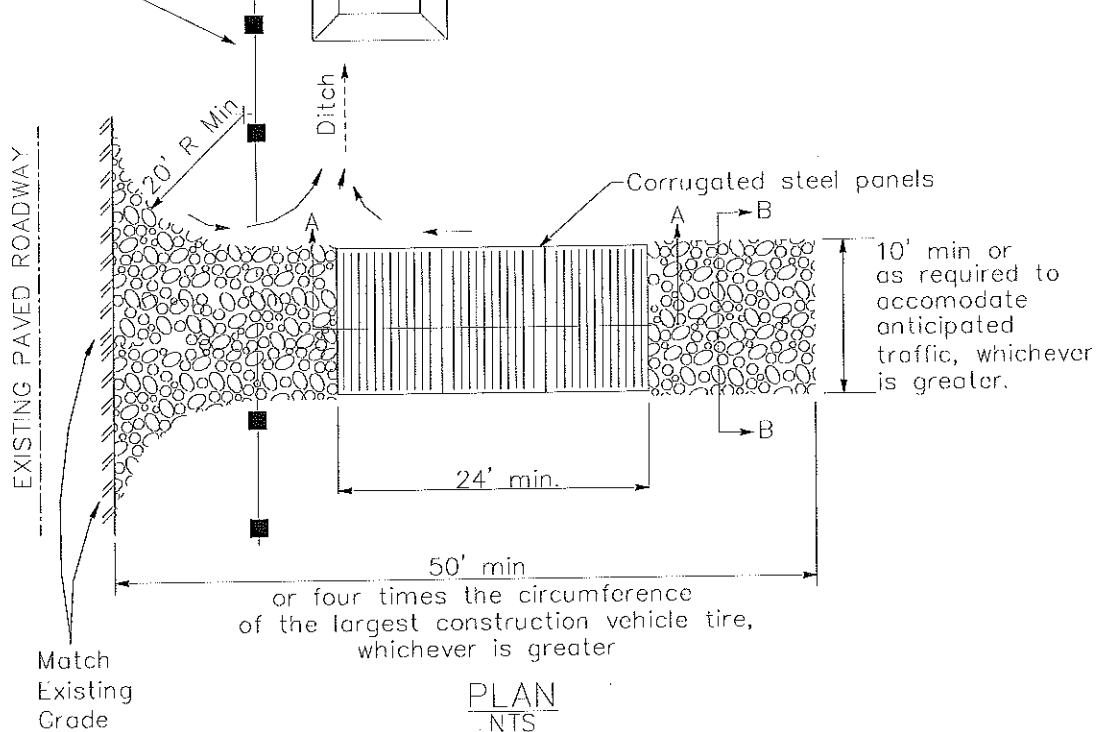

Section 4 Non-Stormwater Management and Material Management BMPs

4.1 Non-Stormwater Management BMPs

The [discharge](#) of materials other than [stormwater](#) and authorized [non-stormwater discharges](#) is prohibited by NPDES regulations as well as other local codes and ordinances. It is recognized that certain authorized non-stormwater discharges may be necessary for the completion of construction projects. Such discharges include but are not limited to irrigation of vegetative [erosion control](#) measures, and pipe flushing and testing.

Non-stormwater management [BMPs](#) are [source control BMPs](#) that prevent pollution by limiting or reducing potential [pollutants](#) at their source or eliminating off-site discharge. These practices involve day-to-day operations of the construction site and are usually under the control of the contractor. These BMPs are also referred to as “good housekeeping practices” which involve keeping a clean, orderly construction site.

Non-stormwater management BMPs also include procedures and practices designed to minimize or eliminate the discharge of pollutants from vehicle and equipment cleaning, fueling, and maintenance operations to stormwater drainage systems or to watercourses.

Table 4-1 lists the non-stormwater management BMPs. All these BMPs must be implemented depending on the conditions and applicability of deployment described as part of the BMP. The key to implementing these BMPs is to maintain a clean site and keep water, runoff, and run-on away from potential pollutants, including bare soil. In general, conduct construction activities so that: potential pollutants are not discharged directly to drainage systems; generation of potential pollutants is limited; and pollutants that are generated are contained and cleaned up immediately and are therefore not available for later discharge. These BMPs are fundamental to water quality protection and all sites must implement non-stormwater BMPs appropriate for the construction activities being performed.

It is recommended that owners and contractors be vigilant regarding implementation of these BMPs, including making their implementation a condition of continued employment, and part

Table 4-1 Non-Stormwater Management BMPs

BMP#	BMP Name
NS-1	Water Conservation Practices
NS-2	Dewatering Operations ¹
NS-3	Paving and Grinding Operations ¹
NS-4	Temporary Stream Crossing
NS-5	Clear Water Diversion
NS-6	Illicit Connection/Discharge
NS-7	Potable Water/Irrigation
NS-8	Vehicle and Equipment Cleaning
NS-9	Vehicle and Equipment Fueling
NS-10	Vehicle and Equipment Maintenance
NS-11	Pile Driving Operations
NS-12	Concrete Curing ¹
NS-13	Concrete Finishing ¹
NS-14	Material and Equipment Use
NS-15	Demolition Adjacent to Water
NS-16	Temporary Batch Plants ¹
1) BMP fact sheet updated in 2009	

of all prime and subcontract agreements. By doing so, the chance of inadvertent violation by an uncaring individual can be prevented, potentially saving thousands of dollars in fines and project delays. Also, if procedures are not properly implemented and/or if BMPs are compromised then the discharge may be subject to additional sampling and analysis requirements for non-visible pollutants contained in the [General Permit](#). (See section 2.5.5 of this handbook.)

4.2 Waste Management & Materials Pollution Control BMPs

[Waste management](#) and materials pollution control BMPs, like non-stormwater management BMPs, are source control BMPs that prevent pollution by limiting or reducing potential pollutants at their source before they come in contact with stormwater. These BMPs also involve day-to-day operations of the construction site, and are under the control of the contractor, and are additional “good housekeeping practices” which involve keeping a clean, orderly construction site. These BMPs are fundamental to water quality protection and all sites must implement waste management and/or materials pollution control non-stormwater BMPs appropriate for the construction activities being performed.

Waste management consists of implementing procedural and structural BMPs for handling, storing, and disposing of wastes generated by a construction project to prevent the release of waste materials into stormwater runoff or discharges through proper management of the following types of wastes:

- Solid
- Sanitary
- Concrete
- Hazardous
- Equipment-related wastes

Materials pollution control (also called materials handling) consists of implementing procedural and structural BMPs in the handling of, storing, and the using of construction materials. The BMPs are intended to prevent the release of pollutants during stormwater and non-stormwater discharges. The objective is to prevent or reduce the opportunity for contamination of stormwater runoff from construction materials by covering and/or providing [secondary containment](#) of storage areas and/or by taking adequate precautions when handling materials.

Table 4-2 Waste Management & Materials Pollution Control BMPs

BMP#	BMP Name
WM-1	Material Delivery and Storage ¹
WM-2	Material Use ¹
WM-3	Stockpile Management ¹
WM-4	Spill Prevention and Control
WM-5	Solid Waste Management
WM-6	Hazardous Waste Management
WM-7	Contaminated Soil Management
WM-8	Concrete Waste Management ¹
WM-9	Sanitary/ Septic Waste Management ¹
WM-10	Liquid Waste Management ¹
1) BMP fact sheet updated in 2009	

These controls must be implemented for all applicable activities, material usage, and site conditions. The discharge of construction materials or wastes from a site is prohibited.

Table 4-2 lists the waste management and materials pollution control BMPs. It is important to note that these BMPs should be implemented depending on the conditions/applicability of deployment described as part of the BMP.

4.3 Fact Sheet Format

A BMP fact sheet is a short document that presents detailed information about a particular BMP. Typically each fact sheet contains the information outlined in Figure 4-1. Completed fact sheets for each of the above activities are provided in Section 4.4.

The fact sheets also contain side bar presentations with information on BMP categories, targeted constituents, removal effectiveness, and potential alternatives.

4.4 BMP Fact Sheets

BMP Fact Sheets for non-stormwater management and waste management and materials pollution control follow. The BMP fact sheets are individually page numbered and are suitable for inclusions in SWPPPs.

Copies of the fact sheets can be individually downloaded from the CASQA BMP Handbook website at <http://www.casqa.org>.

NS-xx Example Fact Sheet

Description and Purpose

Suitable Applications

Limitations

Implementation

Costs

Inspection and Maintenance

References

**Figure 4-1
Example Fact Sheet**

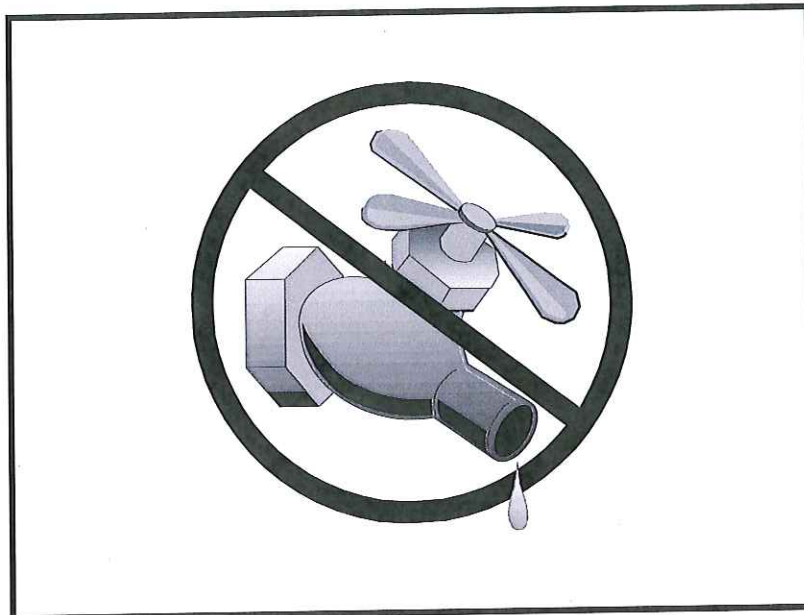

Description and Purpose

Water conservation practices are activities that use water during the construction of a project in a manner that avoids causing erosion and the transport of pollutants offsite. These practices can reduce or eliminate non-stormwater discharges.

Suitable Applications

Water conservation practices are suitable for all construction sites where water is used, including piped water, metered water, trucked water, and water from a reservoir.

Limitations

- None identified.

Implementation

- Keep water equipment in good working condition.
- Stabilize water truck filling area.
- Repair water leaks promptly.
- Washing of vehicles and equipment on the construction site is discouraged.
- Avoid using water to clean construction areas. If water must be used for cleaning or surface preparation, surface should be swept and vacuumed first to remove dirt. This will minimize amount of water required.
- Direct construction water runoff to areas where it can soak

Categories

EC	Erosion Control	<input checked="" type="checkbox"/>
SE	Sediment Control	<input checked="" type="checkbox"/>
TC	Tracking Control	
WE	Wind Erosion Control	
NS	Non-Stormwater Management Control	<input checked="" type="checkbox"/>
WM	Waste Management and Materials Pollution Control	

Legend:

- Primary Objective
- Secondary Objective

Targeted Constituents

Sediment	<input checked="" type="checkbox"/>
Nutrients	
Trash	
Metals	
Bacteria	
Oil and Grease	
Organics	

Potential Alternatives

None



into the ground or be collected and reused.

- Authorized non-stormwater discharges to the storm drain system, channels, or receiving waters are acceptable with the implementation of appropriate BMPs.
- Lock water tank valves to prevent unauthorized use.

Costs

The cost is small to none compared to the benefits of conserving water.

Inspection and Maintenance

- Inspect and verify that activity based BMPs are in place prior to the commencement of authorized non-stormwater discharges.
- Inspect BMPs subject to non-stormwater discharges daily while non-stormwater discharges are occurring.
- Repair water equipment as needed to prevent unintended discharges.
 - Water trucks
 - Water reservoirs (water buffalos)
 - Irrigation systems
 - Hydrant connections

References

Stormwater Quality Handbooks - Construction Site Best Management Practices (BMPs) Manual, State of California Department of Transportation (Caltrans), November 2000.

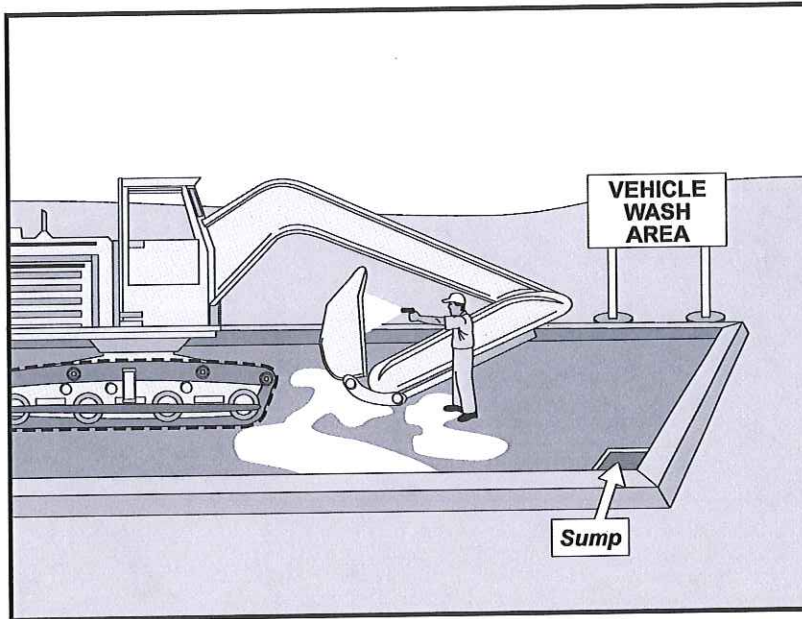

Description and Purpose

Vehicle and equipment cleaning procedures and practices eliminate or reduce the discharge of pollutants to stormwater from vehicle and equipment cleaning operations. Procedures and practices include but are not limited to: using offsite facilities; washing in designated, contained areas only; eliminating discharges to the storm drain by infiltrating the wash water; and training employees and subcontractors in proper cleaning procedures.

Suitable Applications

These procedures are suitable on all construction sites where vehicle and equipment cleaning is performed.

Limitations

Even phosphate-free, biodegradable soaps have been shown to be toxic to fish before the soap degrades. Sending vehicles/equipment offsite should be done in conjunction with TC-1, Stabilized Construction Entrance/Exit.

Implementation

Other options to washing equipment onsite include contracting with either an offsite or mobile commercial washing business. These businesses may be better equipped to handle and dispose of the wash waters properly. Performing this work offsite can also be economical by eliminating the need for a separate washing operation onsite.

If washing operations are to take place onsite, then:

Categories

EC	Erosion Control	
SE	Sediment Control	
TC	Tracking Control	
WE	Wind Erosion Control	
NS	Non-Stormwater Management Control	<input checked="" type="checkbox"/>
WM	Waste Management and Materials Pollution Control	

Legend:

- Primary Objective
- Secondary Objective

Targeted Constituents

Sediment	<input checked="" type="checkbox"/>
Nutrients	<input checked="" type="checkbox"/>
Trash	
Metals	
Bacteria	
Oil and Grease	<input checked="" type="checkbox"/>
Organics	<input checked="" type="checkbox"/>

Potential Alternatives

None



- Use phosphate-free, biodegradable soaps.
- Educate employees and subcontractors on pollution prevention measures.
- Do not permit steam cleaning onsite. Steam cleaning can generate significant pollutant concentrates.
- Cleaning of vehicles and equipment with soap, solvents or steam should not occur on the project site unless resulting wastes are fully contained and disposed of. Resulting wastes should not be discharged or buried, and must be captured and recycled or disposed according to the requirements of WM-10, Liquid Waste Management or WM-6, Hazardous Waste Management, depending on the waste characteristics. Minimize use of solvents. Use of diesel for vehicle and equipment cleaning is prohibited.
- All vehicles and equipment that regularly enter and leave the construction site must be cleaned offsite.
- When vehicle and equipment washing and cleaning must occur onsite, and the operation cannot be located within a structure or building equipped with appropriate disposal facilities, the outside cleaning area should have the following characteristics:
 - Located away from storm drain inlets, drainage facilities, or watercourses
 - Paved with concrete or asphalt and bermed to contain wash waters and to prevent runoff and runoff
 - Configured with a sump to allow collection and disposal of wash water
 - No discharge of wash waters to storm drains or watercourses
 - Used only when necessary
- When cleaning vehicles and equipment with water:
 - Use as little water as possible. High-pressure sprayers may use less water than a hose and should be considered
 - Use positive shutoff valve to minimize water usage
 - Facility wash racks should discharge to a sanitary sewer, recycle system or other approved discharge system and must not discharge to the storm drainage system, watercourses, or to groundwater

Costs

Cleaning vehicles and equipment at an offsite facility may reduce overall costs for vehicle and equipment cleaning by eliminating the need to provide similar services onsite. When onsite cleaning is needed, the cost to establish appropriate facilities is relatively low on larger, long-duration projects, and moderate to high on small, short-duration projects.

Inspection and Maintenance

- Inspect and verify that activity-based BMPs are in place prior to the commencement of associated activities. While activities associated with the BMP are under way, inspect weekly during the rainy season and at two-week intervals in the non-rainy season to verify continued BMP implementation.
- Inspect BMPs subject to non-stormwater discharges daily while non-stormwater discharges occur.
- Inspection and maintenance is minimal, although some berm repair may be necessary.
- Monitor employees and subcontractors throughout the duration of the construction project to ensure appropriate practices are being implemented.
- Inspect sump regularly and remove liquids and sediment as needed.
- Prohibit employees and subcontractors from washing personal vehicles and equipment on the construction site.

References

Stormwater Quality Handbooks - Construction Site Best Management Practices (BMPs) Manual, State of California Department of Transportation (Caltrans), November 2000.

Swisher, R.D. Surfactant Biodegradation, Marcel Decker Corporation, 1987.

of construction. Clearly show how the rainy season relates to soil disturbing and re-stabilization activities. Incorporate the construction schedule into the SWPPP.

- Include on the schedule, details on the rainy season implementation and deployment of:
 - Erosion control BMPs
 - Sediment control BMPs
 - Tracking control BMPs
 - Wind erosion control BMPs
 - Non-stormwater BMPs
 - Waste management and materials pollution control BMPs
- Include dates for activities that may require non-stormwater discharges such as dewatering, sawcutting, grinding, drilling, boring, crushing, blasting, painting, hydro-demolition, mortar mixing, pavement cleaning, etc.
- Work out the sequencing and timetable for the start and completion of each item such as site clearing and grubbing, grading, excavation, paving, foundation pouring utilities installation, etc., to minimize the active construction area during the rainy season.
 - Sequence trenching activities so that most open portions are closed before new trenching begins.
 - Incorporate staged seeding and re-vegetation of graded slopes as work progresses.
 - Schedule establishment of permanent vegetation during appropriate planting time for specified vegetation.
- Non-active areas should be stabilized as soon as practical after the cessation of soil disturbing activities or one day prior to the onset of precipitation.
- Monitor the weather forecast for rainfall.
- When rainfall is predicted, adjust the construction schedule to allow the implementation of soil stabilization and sediment treatment controls on all disturbed areas prior to the onset of rain.
- Be prepared year round to deploy erosion control and sediment control BMPs. Erosion may be caused during dry seasons by un-seasonal rainfall, wind, and vehicle tracking. Keep the site stabilized year round, and retain and maintain rainy season sediment trapping devices in operational condition.
- Apply permanent erosion control to areas deemed substantially complete during the project's defined seeding window.

Costs

Construction scheduling to reduce erosion may increase other construction costs due to reduced economies of scale in performing site grading. The cost effectiveness of scheduling techniques should be compared with the other less effective erosion and sedimentation controls to achieve a cost effective balance.

Inspection and Maintenance

- Verify that work is progressing in accordance with the schedule. If progress deviates, take corrective actions.
- Amend the schedule when changes are warranted.
- Amend the schedule prior to the rainy season to show updated information on the deployment and implementation of construction site BMPs.

References

Stormwater Quality Handbooks Construction Site Best Management Practices (BMPs) Manual, State of California Department of Transportation (Caltrans), November 2000.

Stormwater Management for Construction Activities Developing Pollution Prevention Plans and Best Management Practices (EPA 832-R-92-005), U.S. Environmental Protection Agency, Office of Water, September 1992.

Preservation Of Existing Vegetation EC-2

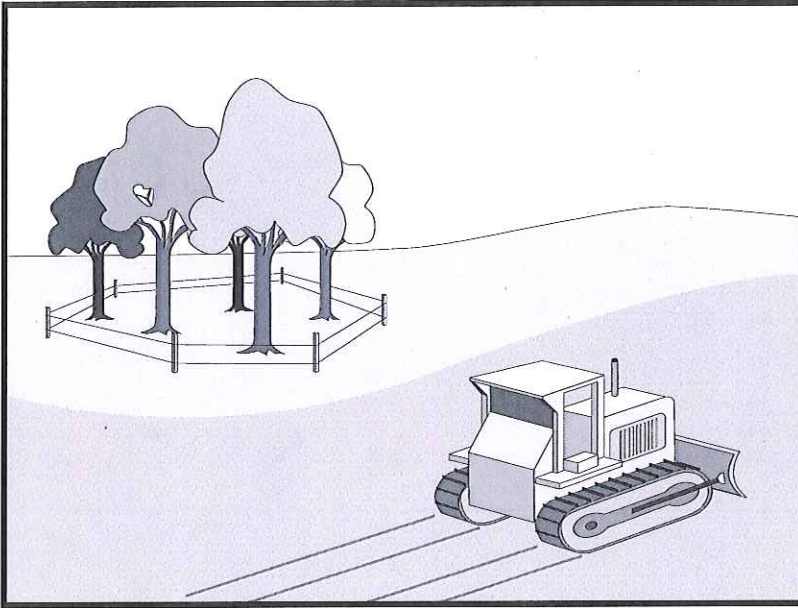

Description and Purpose

Carefully planned preservation of existing vegetation minimizes the potential of removing or injuring existing trees, vines, shrubs, and grasses that protect soil from erosion.

Suitable Applications

Preservation of existing vegetation is suitable for use on most projects. Large project sites often provide the greatest opportunity for use of this BMP. Suitable applications include the following:

- Areas within the site where no construction activity occurs, or occurs at a later date. This BMP is especially suitable to multi year projects where grading can be phased.
- Areas where natural vegetation exists and is designated for preservation. Such areas often include steep slopes, watercourse, and building sites in wooded areas.
- Areas where local, state, and federal government require preservation, such as vernal pools, wetlands, marshes, certain oak trees, etc. These areas are usually designated on the plans, or in the specifications, permits, or environmental documents.
- Where vegetation designated for ultimate removal can be temporarily preserved and be utilized for erosion control and sediment control.

Limitations

- Requires forward planning by the owner/developer,

Categories

EC	Erosion Control	<input checked="" type="checkbox"/>
SE	Sediment Control	<input type="checkbox"/>
TC	Tracking Control	<input type="checkbox"/>
WE	Wind Erosion Control	<input type="checkbox"/>
NS	Non-Stormwater Management Control	<input type="checkbox"/>
WM	Waste Management and Materials Pollution Control	<input type="checkbox"/>

Legend:

- Primary Objective
- Secondary Objective

Targeted Constituents

Sediment	<input checked="" type="checkbox"/>
Nutrients	<input type="checkbox"/>
Trash	<input type="checkbox"/>
Metals	<input type="checkbox"/>
Bacteria	<input type="checkbox"/>
Oil and Grease	<input type="checkbox"/>
Organics	<input type="checkbox"/>

Potential Alternatives

None



Preservation Of Existing Vegetation EC-2

contractor, and design staff.

- Limited opportunities for use when project plans do not incorporate existing vegetation into the site design.
- For sites with diverse topography, it is often difficult and expensive to save existing trees while grading the site satisfactory for the planned development.

Implementation

The best way to prevent erosion is to not disturb the land. In order to reduce the impacts of new development and redevelopment, projects may be designed to avoid disturbing land in sensitive areas of the site (e.g., natural watercourses, steep slopes), and to incorporate unique or desirable existing vegetation into the site's landscaping plan. Clearly marking and leaving a buffer area around these unique areas during construction will help to preserve these areas as well as take advantage of natural erosion prevention and sediment trapping.

Existing vegetation to be preserved on the site must be protected from mechanical and other injury while the land is being developed. The purpose of protecting existing vegetation is to ensure the survival of desirable vegetation for shade, beautification, and erosion control. Mature vegetation has extensive root systems that help to hold soil in place, thus reducing erosion. In addition, vegetation helps keep soil from drying rapidly and becoming susceptible to erosion. To effectively save existing vegetation, no disturbances of any kind should be allowed within a defined area around the vegetation. For trees, no construction activity should occur within the drip line of the tree.

Timing

- Provide for preservation of existing vegetation prior to the commencement of clearing and grubbing operations or other soil disturbing activities in areas where no construction activity is planned or will occur at a later date.

Design and Layout

- Mark areas to be preserved with temporary fencing. Include sufficient setback to protect roots.
 - Orange colored plastic mesh fencing works well.
 - Use appropriate fence posts and adequate post spacing and depth to completely support the fence in an upright position.
- Locate temporary roadways, stockpiles, and layout areas to avoid stands of trees, shrubs, and grass.
- Consider the impact of grade changes to existing vegetation and the root zone.
- Maintain existing irrigation systems where feasible. Temporary irrigation may be required.
- Instruct employees and subcontractors to honor protective devices. Prohibit heavy equipment, vehicular traffic, or storage of construction materials within the protected area.

Preservation Of Existing Vegetation EC-2

Costs

There is little cost associated with preserving existing vegetation if properly planned during the project design, and these costs may be offset by aesthetic benefits that enhance property values. During construction, the cost for preserving existing vegetation will likely be less than the cost of applying erosion and sediment controls to the disturbed area. Replacing vegetation inadvertently destroyed during construction can be extremely expensive, sometimes in excess of \$10,000 per tree.

Inspection and Maintenance

During construction, the limits of disturbance should remain clearly marked at all times. Irrigation or maintenance of existing vegetation should be described in the landscaping plan. If damage to protected trees still occurs, maintenance guidelines described below should be followed:

- Verify that protective measures remain in place. Restore damaged protection measures immediately.
- Serious tree injuries shall be attended to by an arborist.
- Damage to the crown, trunk, or root system of a retained tree shall be repaired immediately.
- Trench as far from tree trunks as possible, usually outside of the tree drip line or canopy. Curve trenches around trees to avoid large roots or root concentrations. If roots are encountered, consider tunneling under them. When trenching or tunneling near or under trees to be retained, place tunnels at least 18 in. below the ground surface, and not below the tree center to minimize impact on the roots.
- Do not leave tree roots exposed to air. Cover exposed roots with soil as soon as possible. If soil covering is not practical, protect exposed roots with wet burlap or peat moss until the tunnel or trench is ready for backfill.
- Cleanly remove the ends of damaged roots with a smooth cut.
- Fill trenches and tunnels as soon as possible. Careful filling and tamping will eliminate air spaces in the soil, which can damage roots.
- If bark damage occurs, cut back all loosened bark into the undamaged area, with the cut tapered at the top and bottom and drainage provided at the base of the wood. Limit cutting the undamaged area as much as possible.
- Aerate soil that has been compacted over a trees root zone by punching holes 12 in. deep with an iron bar, and moving the bar back and forth until the soil is loosened. Place holes 18 in. apart throughout the area of compacted soil under the tree crown.
- Fertilization
 - Fertilize stressed or damaged broadleaf trees to aid recovery.
 - Fertilize trees in the late fall or early spring.

Preservation Of Existing Vegetation EC-2

- Apply fertilizer to the soil over the feeder roots and in accordance with label instructions, but never closer than 3 ft to the trunk. Increase the fertilized area by one-fourth of the crown area for conifers that have extended root systems.
- Retain protective measures until all other construction activity is complete to avoid damage during site cleanup and stabilization.

References

County of Sacramento Tree Preservation Ordinance, September 1981.

Stormwater Quality Handbooks Construction Site Best Management Practices (BMPs) Manual, State of California Department of Transportation (Caltrans), November 2000.

Stormwater Management of the Puget Sound Basin, Technical Manual, Publication #91-75, Washington State Department of Ecology, February 1992.

Water Quality Management Plan for The Lake Tahoe Region, Volume II, Handbook of Management Practices, Tahoe Regional Planning Agency, November 1988.



Description and Purpose

A silt fence is made of a woven geotextile that has been entrenched, attached to supporting poles, and sometimes backed by a plastic or wire mesh for support. The silt fence detains sediment-laden water, promoting sedimentation behind the fence.

Suitable Applications

Silt fences are suitable for perimeter control, placed below areas where sheet flows discharge from the site. They could also be used as interior controls below disturbed areas where runoff may occur in the form of sheet and rill erosion and around inlets within disturbed areas (SE-10). Silt fences are generally ineffective in locations where the flow is concentrated and are only applicable for sheet or overland flows. Silt fences are most effective when used in combination with erosion controls. Suitable applications include:

- Along the perimeter of a project.
- Below the toe or down slope of exposed and erodible slopes.
- Along streams and channels.
- Around temporary spoil areas and stockpiles.
- Around inlets.
- Below other small cleared areas.

Categories

EC	Erosion Control	
SE	Sediment Control	<input checked="" type="checkbox"/>
TC	Tracking Control	
WE	Wind Erosion Control	
NS	Non-Stormwater Management Control	
WM	Waste Management and Materials Pollution Control	

Legend:

- Primary Category
- Secondary Category

Targeted Constituents

Sediment	<input checked="" type="checkbox"/>
Nutrients	
Trash	
Metals	
Bacteria	
Oil and Grease	
Organics	

Potential Alternatives

- SE-5 Fiber Rolls
- SE-6 Gravel Bag Berm
- SE-8 Sandbag Barrier
- SE-10 Storm Drain Inlet Protection
- SE-14 Biofilter Bags



Limitations

- Do not use in streams, channels, drain inlets, or anywhere flow is concentrated.
- Do not use in locations where ponded water may cause a flooding hazard. Runoff typically ponds temporarily on the upstream side of silt fence.
- Do not use silt fence to divert water flows or place across any contour line. Fences not constructed on a level contour, or fences used to divert flow will concentrate flows resulting in additional erosion and possibly overtopping or failure of the silt fence.
- Improperly installed fences are subject to failure from undercutting, overtopping, or collapsing.
- Not effective unless trenched and keyed in.
- Not intended for use as mid-slope protection on slopes greater than 4:1 (H:V).
- Do not use on slopes subject to creeping, slumping, or landslides.

Implementation

General

A silt fence is a temporary sediment barrier consisting of woven geotextile stretched across and attached to supporting posts, trenched-in, and, depending upon the strength of fabric used, supported with plastic or wire mesh fence. Silt fences trap sediment by intercepting and detaining small amounts of sediment-laden runoff from disturbed areas in order to promote sedimentation behind the fence.

The following layout and installation guidance can improve performance and should be followed:

- Use principally in areas where sheet flow occurs.
- Install along a level contour, so water does not pond more than 1.5 ft at any point along the silt fence.
- The maximum length of slope draining to any point along the silt fence should be 200 ft or less.
- The maximum slope perpendicular to the fence line should be 1:1.
- Provide sufficient room for runoff to pond behind the fence and to allow sediment removal equipment to pass between the silt fence and toes of slopes or other obstructions. About 1200 ft² of ponding area should be provided for every acre draining to the fence.
- Turn the ends of the filter fence uphill to prevent stormwater from flowing around the fence.
- Leave an undisturbed or stabilized area immediately down slope from the fence where feasible.

- Silt fences should remain in place until the disturbed area is permanently stabilized, after which, the silt fence should be removed and properly disposed.
- Silt fence should be used in combination with erosion source controls up slope in order to provide the most effective sediment control.
- Be aware of local regulations regarding the type and installation requirements of silt fence, which may differ from those presented in this fact sheet.

Design and Layout

The fence should be supported by a plastic or wire mesh if the fabric selected does not have sufficient strength and bursting strength characteristics for the planned application (as recommended by the fabric manufacturer). Woven geotextile material should contain ultraviolet inhibitors and stabilizers to provide a minimum of six months of expected usable construction life at a temperature range of 0 °F to 120 °F.

- Layout in accordance with attached figures.
- For slopes steeper than 2:1 (H:V) and that contain a high number of rocks or large dirt clods that tend to dislodge, it may be necessary to install additional protection immediately adjacent to the bottom of the slope, prior to installing silt fence. Additional protection may be a chain link fence or a cable fence.
- For slopes adjacent to sensitive receiving waters or Environmentally Sensitive Areas (ESAs), silt fence should be used in conjunction with erosion control BMPs.

Standard vs. Heavy Duty Silt Fence

Standard Silt Fence

- Generally applicable in cases where the slope of area draining to the silt fence is 4:1 (H:V) or less.
- Used for shorter durations, typically 5 months or less
- Area draining to fence produces moderate sediment loads.

Heavy Duty Silt Fence

- Use is generally limited to 8 months or less.
- Area draining to fence produces moderate sediment loads.
- Heavy duty silt fence usually has 1 or more of the following characteristics, not possessed by standard silt fence.
 - Fence fabric has higher tensile strength.
 - Fabric is reinforced with wire backing or additional support.
 - Posts are spaced closer than pre-manufactured, standard silt fence products.
 - Posts are metal (steel or aluminum)

Materials

Standard Silt Fence

- Silt fence material should be woven geotextile with a minimum width of 36 in. and a minimum tensile strength of 100 lb force. The fabric should conform to the requirements in ASTM designation D4632 and should have an integral reinforcement layer. The

reinforcement layer should be a polypropylene, or equivalent, net provided by the manufacturer. The permittivity of the fabric should be between 0.1 sec^{-1} and 0.15 sec^{-1} in conformance with the requirements in ASTM designation D4491.

- Wood stakes should be commercial quality lumber of the size and shape shown on the plans. Each stake should be free from decay, splits or cracks longer than the thickness of the stake or other defects that would weaken the stakes and cause the stakes to be structurally unsuitable.
- Staples used to fasten the fence fabric to the stakes should be not less than 1.75 in. long and should be fabricated from 15 gauge or heavier wire. The wire used to fasten the tops of the stakes together when joining two sections of fence should be 9 gauge or heavier wire. Galvanizing of the fastening wire will not be required.

Heavy-Duty Silt Fence

- Some silt fence has a wire backing to provide additional support, and there are products that may use prefabricated plastic holders for the silt fence and use metal posts or bar reinforcement instead of wood stakes. If bar reinforcement is used in lieu of wood stakes, use number four or greater bar. Provide end protection for any exposed bar reinforcement for health and safety purposes.

Installation Guidelines – Traditional Method

Silt fences are to be constructed on a level contour. Sufficient area should exist behind the fence for ponding to occur without flooding or overtopping the fence.

- A trench should be excavated approximately 6 in. wide and 6 in. deep along the line of the proposed silt fence (trenches should not be excavated wider or deeper than necessary for proper silt fence installation).
- Bottom of the silt fence should be keyed-in a minimum of 12 in.
- Posts should be spaced a maximum of 6 ft apart and driven securely into the ground a minimum of 18 in. or 12 in. below the bottom of the trench.
- When standard strength geotextile is used, a plastic or wire mesh support fence should be fastened securely to the upslope side of posts using heavy-duty wire staples at least 1 in. long. The mesh should extend into the trench.
- When extra-strength geotextile and closer post spacing are used, the mesh support fence may be eliminated.
- Woven geotextile should be purchased in a long roll, then cut to the length of the barrier. When joints are necessary, geotextile should be spliced together only at a support post, with a minimum 6 in. overlap and both ends securely fastened to the post.
- The trench should be backfilled with native material and compacted.
- Construct silt fences with a setback of at least 3 ft from the toe of a slope. Where, due to specific site conditions, a 3 ft setback is not available, the silt fence may be constructed at the

toe of the slope, but should be constructed as far from the toe of the slope as practicable. Silt fences close to the toe of the slope will be less effective and more difficult to maintain.

- Construct the length of each reach so that the change in base elevation along the reach does not exceed $\frac{1}{3}$ the height of the barrier; in no case should the reach exceed 500 ft.
- Cross barriers should be a minimum of $\frac{1}{3}$ and a maximum of $\frac{1}{2}$ the height of the linear barrier.
- See typical installation details at the end of this fact sheet.

Installation Guidelines - Static Slicing Method

- Static Slicing is defined as insertion of a narrow blade pulled behind a tractor, similar to a plow blade, at least 10 inches into the soil while at the same time pulling silt geotextile fabric into the ground through the opening created by the blade to the depth of the blade. Once the geotextile is installed, the soil is compacted using tractor tires.
- This method will not work with pre-fabricated, wire backed silt fence.
- Benefits:
 - Ease of installation (most often done with a 2 person crew). In addition, installation using static slicing has been found to be more efficient on slopes, in rocky soils, and in saturated soils.
 - Minimal soil disturbance.
 - Greater level of compaction along fence, leading to higher performance (i.e. greater sediment retention).
 - Uniform installation.
 - Less susceptible to undercutting/undermining.

Costs

- It should be noted that costs vary greatly across regions due to available supplies and labor costs.
- Average annual cost for installation using the traditional silt fence installation method (assumes 6 month useful life) is \$7 per linear foot based on vendor research. Range of cost is \$3.50 - \$9.10 per linear foot.
- In tests, the slicing method required 0.33 man hours per 100 linear feet, while the trenched based systems required as much as 1.01 man hours per linear foot.

Inspection and Maintenance

- BMPs must be inspected in accordance with General Permit requirements for the associated project type and risk level. It is recommended that at a minimum, BMPs be inspected weekly, prior to forecasted rain events, daily during extended rain events, and after the conclusion of rain events.
- Repair undercut silt fences.

- Repair or replace split, torn, slumping, or weathered fabric. The lifespan of silt fence fabric is generally 5 to 8 months.
- Silt fences that are damaged and become unsuitable for the intended purpose should be removed from the site of work, disposed, and replaced with new silt fence barriers.
- Sediment that accumulates in the BMP should be periodically removed in order to maintain BMP effectiveness. Sediment should be removed when the sediment accumulation reaches one-third of the barrier height.
- Silt fences should be left in place until the upstream area is permanently stabilized. Until then, the silt fence should be inspected and maintained regularly.
- Remove silt fence when upgradient areas are stabilized. Fill and compact post holes and anchor trench, remove sediment accumulation, grade fence alignment to blend with adjacent ground, and stabilize disturbed area.

References

Manual of Standards of Erosion and Sediment Control Measures, Association of Bay Area Governments, May 1995.

National Management Measures to Control Nonpoint Source Pollution from Urban Areas, United States Environmental Protection Agency, 2002.

Proposed Guidance Specifying Management Measures for Sources of Nonpoint Pollution in Coastal Waters, Work Group-Working Paper, USEPA, April 1992.

Sedimentation and Erosion Control Practices, and Inventory of Current Practices (Draft), UESPA, 1990.

Southeastern Wisconsin Regional Planning Commission (SWRPC). Costs of Urban Nonpoint Source Water Pollution Control Measures. Technical Report No. 31. Southeastern Wisconsin Regional Planning Commission, Waukesha, WI. 1991

Stormwater Quality Handbooks - Construction Site Best Management Practices (BMPs) Manual, State of California Department of Transportation (Caltrans), March 2003.

Stormwater Management Manual for The Puget Sound Basin, Washington State Department of Ecology, Public Review Draft, 1991.

U.S. Environmental Protection Agency (USEPA). Stormwater Management for Industrial Activities: Developing Pollution Prevention Plans and Best Management Practices. U.S. Environmental Protection Agency, Office of Water, Washington, DC, 1992.

Water Quality Management Plan for the Lake Tahoe Region, Volume II, Handbook of Management Practices, Tahoe Regional Planning Agency, November 1988. Soil Stabilization BMP Research for Erosion and Sediment Controls: Cost Survey Technical Memorandum, State of California Department of Transportation (Caltrans), July 2007.

Erosion and Sediment Control Manual, Oregon Department of Environmental Quality, February 2005.

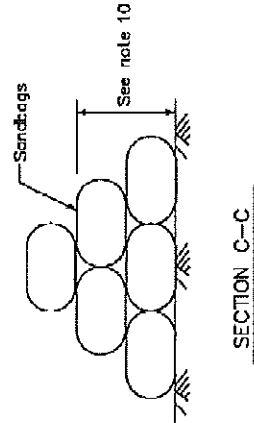
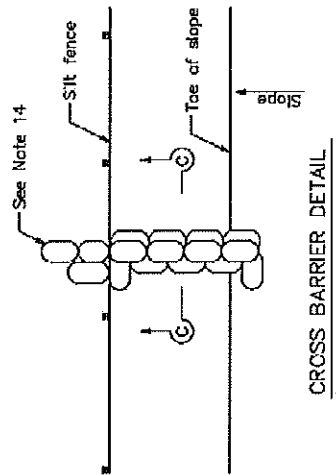
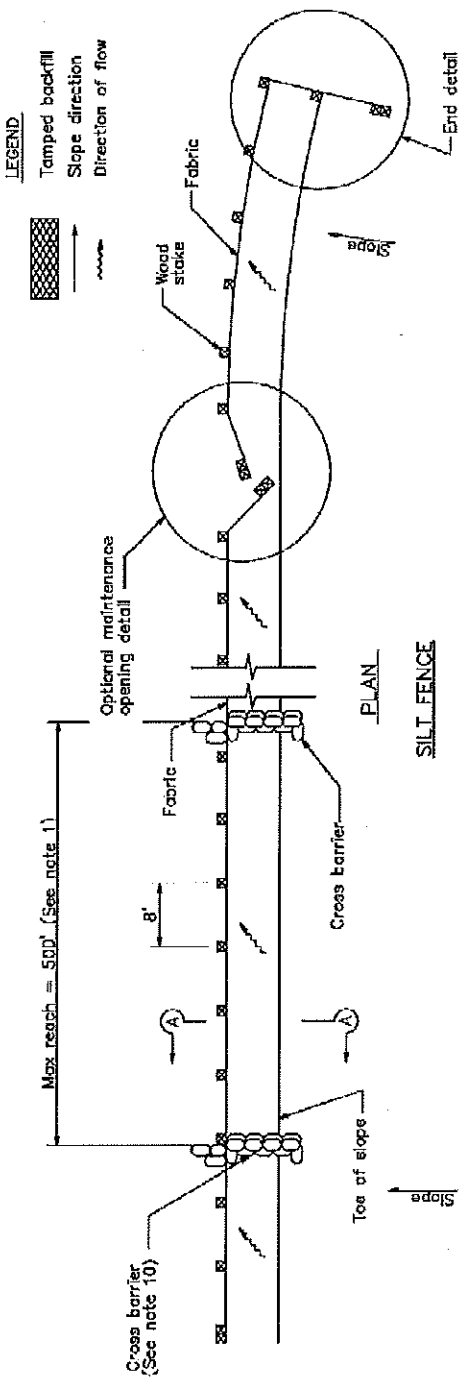

NOTES

1. Construct the length of each reach so that the change in base elevation along the reach does not exceed 1/3 the height of the linear barrier. In no case shall the reach length exceed 500'.
2. The last 8'-0" of fence shall be turned up slope.
3. Stake dimensions are nominal.
4. Dimension may vary to fit field condition.
5. Stakes shall be spaced at 8'-0" maximum and shall be positioned on downstream side of fence.
6. Stakes to overlap and fence fabric to fold around each stake one full turn. Secure fabric to stake with 4 staples.
7. Stakes shall be driven tightly together to prevent potential flow-through of sediment at joint. The tops of the stakes shall be secured with wire.
8. For end stake, fence fabric shall be folded around two stakes one full turn and secured with 4 staples.
9. Minimum 4 staples per stake. Dimensions shown are typical.
10. Cross barriers shall be a minimum of 1/3 and a maximum of 1/2 the height of the linear barrier.
11. Maintenance openings shall be constructed in a manner to ensure sediment remains behind silt fence.
12. Joining sections shall not be placed at sump locations.
13. Sandbag rows and layers shall be offset to eliminate gaps.
14. Add 3-4 bags to cross barrier on downgradient side of silt fence as needed to prevent bypass or undermining and as allowable based on site limits of disturbance.

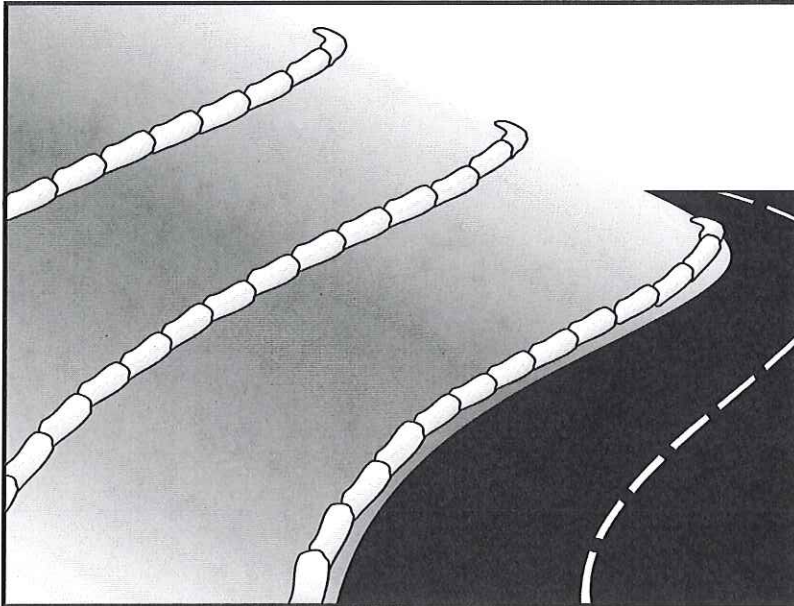

Description and Purpose

A gravel bag berm is a series of gravel-filled bags placed on a level contour to intercept sheet flows. Gravel bags pond sheet flow runoff, allowing sediment to settle out, and release runoff slowly as sheet flow, preventing erosion.

Suitable Applications

Gravel bag berms may be suitable:

- As a linear sediment control measure:
 - Below the toe of slopes and erodible slopes
 - As sediment traps at culvert/pipe outlets
 - Below other small cleared areas
 - Along the perimeter of a site
 - Down slope of exposed soil areas
 - Around temporary stockpiles and spoil areas
 - Parallel to a roadway to keep sediment off paved areas
 - Along streams and channels
- As a linear erosion control measure:
 - Along the face and at grade breaks of exposed and erodible slopes to shorten slope length and spread runoff as sheet flow.

Categories

EC	Erosion Control	<input checked="" type="checkbox"/>
SE	Sediment Control	<input checked="" type="checkbox"/>
TC	Tracking Control	
WE	Wind Erosion Control	
NS	Non-Stormwater Management Control	
WM	Waste Management and Materials Pollution Control	

Legend:

- Primary Category
- Secondary Category

Targeted Constituents

Sediment	<input checked="" type="checkbox"/>
Nutrients	
Trash	
Metals	
Bacteria	
Oil and Grease	
Organics	

Potential Alternatives

- SE-1 Silt Fence
- SE-5 Fiber Roll
- SE-8 Sandbag Barrier
- SE-14 Biofilter Bags



- At the top of slopes to divert runoff away from disturbed slopes.
- As chevrons (small check dams) across mildly sloped construction roads. For use check dam use in channels, see SE-4, Check Dams.

Limitations

- Gravel berms may be difficult to remove.
- Removal problems limit their usefulness in landscaped areas.
- Gravel bag berm may not be appropriate for drainage areas greater than 5 acres.
- Runoff will pond upstream of the berm, possibly causing flooding if sufficient space does not exist.
- Degraded gravel bags may rupture when removed, spilling contents.
- Installation can be labor intensive.
- Durability of gravel bags is somewhat limited and bags may need to be replaced when installation is required for longer than 6 months.
- Easily damaged by construction equipment.
- When used to detain concentrated flows, maintenance requirements increase.

Implementation

General

A gravel bag berm consists of a row of open graded gravel-filled bags placed on a level contour. When appropriately placed, a gravel bag berm intercepts and slows sheet flow runoff, causing temporary ponding. The temporary ponding allows sediment to settle. The open graded gravel in the bags is porous, which allows the ponded runoff to flow slowly through the bags, releasing the runoff as sheet flows. Gravel bag berms also interrupt the slope length and thereby reduce erosion by reducing the tendency of sheet flows to concentrate into rivulets, which erode rills, and ultimately gullies, into disturbed, sloped soils. Gravel bag berms are similar to sand bag barriers, but are more porous. Generally, gravel bag berms should be used in conjunction with temporary soil stabilization controls up slope to provide effective erosion and sediment control.

Design and Layout

- Locate gravel bag berms on level contours.
- When used for slope interruption, the following slope/sheet flow length combinations apply:
 - Slope inclination of 4:1 (H:V) or flatter: Gravel bags should be placed at a maximum interval of 20 ft, with the first row near the slope toe.
 - Slope inclination between 4:1 and 2:1 (H:V): Gravel bags should be placed at a maximum interval of 15 ft. (a closer spacing is more effective), with the first row near the slope toe.

Slope inclination 2:1 (H:V) or greater: Gravel bags should be placed at a maximum interval of 10 ft. (a closer spacing is more effective), with the first row near the slope toe.

- Turn the ends of the gravel bag barriers up slope to prevent runoff from going around the berm.
- Allow sufficient space up slope from the gravel bag berm to allow ponding, and to provide room for sediment storage.
- For installation near the toe of the slope, gravel bag barriers should be set back from the slope toe to facilitate cleaning. Where specific site conditions do not allow for a set-back, the gravel bag barrier may be constructed on the toe of the slope. To prevent flows behind the barrier, bags can be placed perpendicular to a berm to serve as cross barriers.
- Drainage area should not exceed 5 acres.
- In Non-Traffic Areas:
 - Height = 18 in. maximum
 - Top width = 24 in. minimum for three or more layer construction
 - Top width = 12 in. minimum for one or two layer construction
 - Side slopes = 2:1 (H:V) or flatter
- In Construction Traffic Areas:
 - Height = 12 in. maximum
 - Top width = 24 in. minimum for three or more layer construction.
 - Top width = 12 in. minimum for one or two layer construction.
 - Side slopes = 2:1 (H:V) or flatter.
- Butt ends of bags tightly.
- On multiple row, or multiple layer construction, overlap butt joints of adjacent row and row beneath.
- Use a pyramid approach when stacking bags.

Materials

- **Bag Material:** Bags should be woven polypropylene, polyethylene or polyamide fabric or burlap, minimum unit weight of 4 ounces/yd², Mullen burst strength exceeding 300 lb/in² in conformance with the requirements in ASTM designation D3786, and ultraviolet stability exceeding 70% in conformance with the requirements in ASTM designation D4355.

- **Bag Size:** Each gravel-filled bag should have a length of 18 in., width of 12 in., thickness of 3 in., and mass of approximately 33 lbs. Bag dimensions are nominal, and may vary based on locally available materials.
- **Fill Material:** Fill material should be 0.5 to 1 in. crushed rock, clean and free from clay, organic matter, and other deleterious material, or other suitable open graded, non-cohesive, porous gravel.

Costs

Material costs for gravel bags are average and are dependent upon material availability. \$2.50-3.00 per filled gravel bag is standard based upon vendor research.

Inspection and Maintenance

- BMPs must be inspected in accordance with General Permit requirements for the associated project type and risk level. It is recommended that at a minimum, BMPs be inspected weekly, prior to forecasted rain events, daily during extended rain events, and after the conclusion of rain events.
- Gravel bags exposed to sunlight will need to be replaced every two to three months due to degrading of the bags.
- Reshape or replace gravel bags as needed.
- Repair washouts or other damage as needed.
- Sediment that accumulates in the BMP should be periodically removed in order to maintain BMP effectiveness. Sediment should be removed when the sediment accumulation reaches one-third of the barrier height.
- Remove gravel bag berms when no longer needed and recycle gravel fill whenever possible and properly dispose of bag material. Remove sediment accumulation and clean, re-grade, and stabilize the area.

References

Handbook of Steel Drainage and Highway Construction, American Iron and Steel Institute, 1983.

Stormwater Quality Handbooks - Construction Site Best Management Practices (BMPs) Manual, State of California Department of Transportation (Caltrans), March 2003.

Stormwater Pollution Plan Handbook, First Edition, State of California, Department of Transportation Division of New Technology, Materials and Research, October 1992.

Erosion and Sediment Control Manual, Oregon Department of Environmental Quality, February 2005.

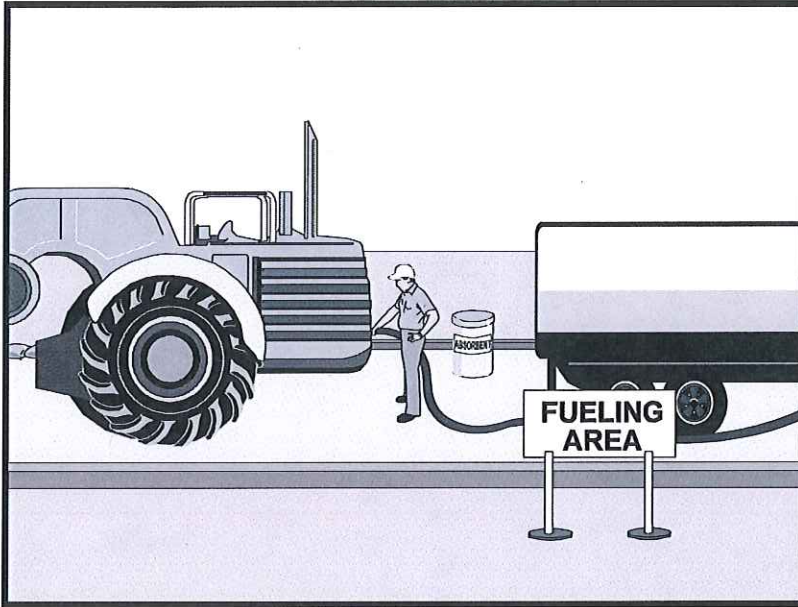

Description and Purpose

Vehicle equipment fueling procedures and practices are designed to prevent fuel spills and leaks, and reduce or eliminate contamination of stormwater. This can be accomplished by using offsite facilities, fueling in designated areas only, enclosing or covering stored fuel, implementing spill controls, and training employees and subcontractors in proper fueling procedures.

Suitable Applications

These procedures are suitable on all construction sites where vehicle and equipment fueling takes place.

Limitations

Onsite vehicle and equipment fueling should only be used where it is impractical to send vehicles and equipment offsite for fueling. Sending vehicles and equipment offsite should be done in conjunction with TC-1, Stabilized Construction Entrance/ Exit.

Implementation

- Use offsite fueling stations as much as possible. These businesses are better equipped to handle fuel and spills properly. Performing this work offsite can also be economical by eliminating the need for a separate fueling area at a site.
- Discourage “topping-off” of fuel tanks.
- Absorbent spill cleanup materials and spill kits should be available in fueling areas and on fueling trucks, and should

Categories

EC	Erosion Control	
SE	Sediment Control	
TC	Tracking Control	
WE	Wind Erosion Control	
NS	Non-Stormwater Management Control	<input checked="" type="checkbox"/>
WM	Waste Management and Materials Pollution Control	

Legend:

- Primary Objective
- Secondary Objective

Targeted Constituents

Sediment	
Nutrients	
Trash	
Metals	
Bacteria	
Oil and Grease	<input checked="" type="checkbox"/>
Organics	

Potential Alternatives

None



be disposed of properly after use.

- Drip pans or absorbent pads should be used during vehicle and equipment fueling, unless the fueling is performed over an impermeable surface in a dedicated fueling area.
- Use absorbent materials on small spills. Do not hose down or bury the spill. Remove the adsorbent materials promptly and dispose of properly.
- Avoid mobile fueling of mobile construction equipment around the site; rather, transport the equipment to designated fueling areas. With the exception of tracked equipment such as bulldozers and large excavators, most vehicles should be able to travel to a designated area with little lost time.
- Train employees and subcontractors in proper fueling and cleanup procedures.
- When fueling must take place onsite, designate an area away from drainage courses to be used. Fueling areas should be identified in the SWPPP.
- Dedicated fueling areas should be protected from stormwater runoff and runoff, and should be located at least 50 ft away from downstream drainage facilities and watercourses. Fueling must be performed on level-grade areas.
- Protect fueling areas with berms and dikes to prevent runoff, runoff, and to contain spills.
- Nozzles used in vehicle and equipment fueling should be equipped with an automatic shutoff to control drips. Fueling operations should not be left unattended.
- Use vapor recovery nozzles to help control drips as well as air pollution where required by Air Quality Management Districts (AQMD).
- Federal, state, and local requirements should be observed for any stationary above ground storage tanks.

Costs

- All of the above measures are low cost except for the capital costs of above ground tanks that meet all local environmental, zoning, and fire codes.

Inspection and Maintenance

- Vehicles and equipment should be inspected each day of use for leaks. Leaks should be repaired immediately or problem vehicles or equipment should be removed from the project site.
- Keep ample supplies of spill cleanup materials onsite.
- Immediately clean up spills and properly dispose of contaminated soil and cleanup materials.

References

Blueprint for a Clean Bay: Best Management Practices to Prevent Stormwater Pollution from Construction Related Activities; Santa Clara Valley Nonpoint Source Pollution Control Program, 1995.

Coastal Nonpoint Pollution Control Program: Program Development and Approval Guidance, Working Group Working Paper; USEPA, April 1992.

Stormwater Quality Handbooks - Construction Site Best Management Practices (BMPs) Manual, State of California Department of Transportation (Caltrans), November 2000.

Stormwater Management for Construction Activities, Developing Pollution Prevention Plans and Best Management Practices, EPA 832-R-92005; USEPA, April 1992.

Vehicle & Equipment Maintenance NS-10

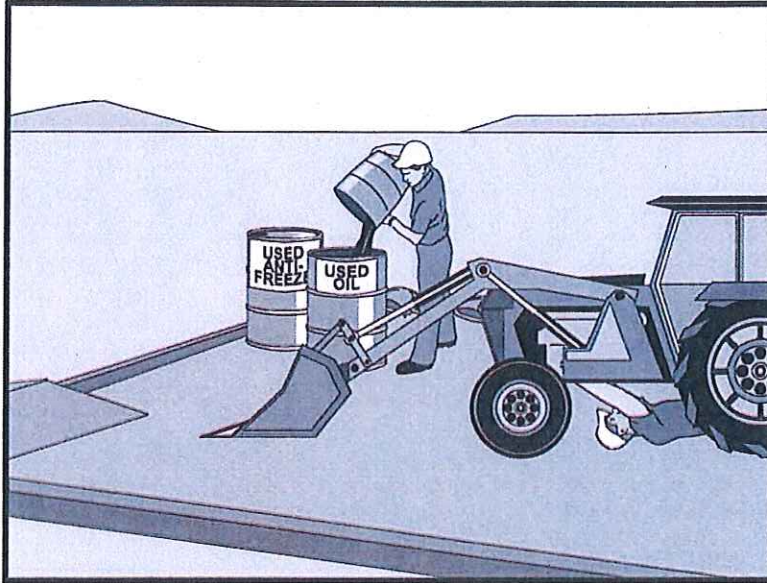

Description and Purpose

Prevent or reduce the contamination of stormwater resulting from vehicle and equipment maintenance by running a “dry and clean site”. The best option would be to perform maintenance activities at an offsite facility. If this option is not available then work should be performed in designated areas only, while providing cover for materials stored outside, checking for leaks and spills, and containing and cleaning up spills immediately. Employees and subcontractors must be trained in proper procedures.

Suitable Applications

These procedures are suitable on all construction projects where an onsite yard area is necessary for storage and maintenance of heavy equipment and vehicles.

Limitations

Onsite vehicle and equipment maintenance should only be used where it is impractical to send vehicles and equipment offsite for maintenance and repair. Sending vehicles/equipment offsite should be done in conjunction with TC-1, Stabilized Construction Entrance/Exit.

Outdoor vehicle or equipment maintenance is a potentially significant source of stormwater pollution. Activities that can contaminate stormwater include engine repair and service, changing or replacement of fluids, and outdoor equipment storage and parking (engine fluid leaks). For further information on vehicle or equipment servicing, see NS-8, Vehicle and Equipment Cleaning, and NS-9, Vehicle and

Categories

EC	Erosion Control	
SE	Sediment Control	
TC	Tracking Control	
WE	Wind Erosion Control	
NS	Non-Stormwater Management Control	<input checked="" type="checkbox"/>
WM	Waste Management and Materials Pollution Control	

Legend:

- Primary Objective
- Secondary Objective

Targeted Constituents

Sediment	
Nutrients	<input checked="" type="checkbox"/>
Trash	<input checked="" type="checkbox"/>
Metals	
Bacteria	
Oil and Grease	<input checked="" type="checkbox"/>
Organics	<input checked="" type="checkbox"/>

Potential Alternatives

None



Vehicle & Equipment Maintenance NS-10

Equipment Fueling.

Implementation

- Use offsite repair shops as much as possible. These businesses are better equipped to handle vehicle fluids and spills properly. Performing this work offsite can also be economical by eliminating the need for a separate maintenance area.
- If maintenance must occur onsite, use designated areas, located away from drainage courses. Dedicated maintenance areas should be protected from stormwater runoff and runoff, and should be located at least 50 ft from downstream drainage facilities and watercourses.
- Drip pans or absorbent pads should be used during vehicle and equipment maintenance work that involves fluids, unless the maintenance work is performed over an impermeable surface in a dedicated maintenance area.
- Place a stockpile of spill cleanup materials where it will be readily accessible.
- All fueling trucks and fueling areas are required to have spill kits and/or use other spill protection devices.
- Use adsorbent materials on small spills. Remove the absorbent materials promptly and dispose of properly.
- Inspect onsite vehicles and equipment daily at startup for leaks, and repair immediately.
- Keep vehicles and equipment clean; do not allow excessive build-up of oil and grease.
- Segregate and recycle wastes, such as greases, used oil or oil filters, antifreeze, cleaning solutions, automotive batteries, hydraulic and transmission fluids. Provide secondary containment and covers for these materials if stored onsite.
- Train employees and subcontractors in proper maintenance and spill cleanup procedures.
- Drip pans or plastic sheeting should be placed under all vehicles and equipment placed on docks, barges, or other structures over water bodies when the vehicle or equipment is planned to be idle for more than 1 hour.
- For long-term projects, consider using portable tents or covers over maintenance areas if maintenance cannot be performed offsite.
- Consider use of new, alternative greases and lubricants, such as adhesive greases, for chassis lubrication and fifth-wheel lubrication.
- Properly dispose of used oils, fluids, lubricants, and spill cleanup materials.
- Do not place used oil in a dumpster or pour into a storm drain or watercourse.
- Properly dispose of or recycle used batteries.
- Do not bury used tires.

Vehicle & Equipment Maintenance NS-10

- Repair leaks of fluids and oil immediately.

Listed below is further information if you must perform vehicle or equipment maintenance onsite.

Safer Alternative Products

- Consider products that are less toxic or hazardous than regular products. These products are often sold under an “environmentally friendly” label.
- Consider use of grease substitutes for lubrication of truck fifth-wheels. Follow manufacturers label for details on specific uses.
- Consider use of plastic friction plates on truck fifth-wheels in lieu of grease. Follow manufacturers label for details on specific uses.

Waste Reduction

Parts are often cleaned using solvents such as trichloroethylene, trichloroethane, or methylene chloride. Many of these cleaners are listed in California Toxic Rule as priority pollutants. These materials are harmful and must not contaminate stormwater. They must be disposed of as a hazardous waste. Reducing the number of solvents makes recycling easier and reduces hazardous waste management costs. Often, one solvent can perform a job as well as two different solvents. Also, if possible, eliminate or reduce the amount of hazardous materials and waste by substituting non-hazardous or less hazardous materials. For example, replace chlorinated organic solvents with non-chlorinated solvents. Non-chlorinated solvents like kerosene or mineral spirits are less toxic and less expensive to dispose of properly. Check the list of active ingredients to see whether it contains chlorinated solvents. The “chlor” term indicates that the solvent is chlorinated. Also, try substituting a wire brush for solvents to clean parts.

Recycling and Disposal

Separating wastes allows for easier recycling and may reduce disposal costs. Keep hazardous wastes separate, do not mix used oil solvents, and keep chlorinated solvents (like, trichloroethane) separate from non-chlorinated solvents (like kerosene and mineral spirits). Promptly transfer used fluids to the proper waste or recycling drums. Don't leave full drip pans or other open containers lying around. Provide cover and secondary containment until these materials can be removed from the site.

Oil filters can be recycled. Ask your oil supplier or recycler about recycling oil filters.

Do not dispose of extra paints and coatings by dumping liquid onto the ground or throwing it into dumpsters. Allow coatings to dry or harden before disposal into covered dumpsters.

Store cracked batteries in a non-leaking secondary container. Do this with all cracked batteries, even if you think all the acid has drained out. If you drop a battery, treat it as if it is cracked. Put it into the containment area until you are sure it is not leaking.

Costs

All of the above are low cost measures. Higher costs are incurred to setup and maintain onsite maintenance areas.

Vehicle & Equipment Maintenance NS-10

Inspection and Maintenance

- Inspect and verify that activity-based BMPs are in place prior to the commencement of associated activities. While activities associated with the BMP are under way, inspect weekly during the rainy season and at two-week intervals in the non-rainy season to verify continued BMP implementation.
- Inspect BMPs subject to non-stormwater discharges daily while non-stormwater discharges occur.
- Keep ample supplies of spill cleanup materials onsite.
- Maintain waste fluid containers in leak proof condition.
- Vehicles and equipment should be inspected on each day of use. Leaks should be repaired immediately or the problem vehicle(s) or equipment should be removed from the project site.
- Inspect equipment for damaged hoses and leaky gaskets routinely. Repair or replace as needed.

References

Blueprint for a Clean Bay: Best Management Practices to Prevent Stormwater Pollution from Construction Related Activities; Santa Clara Valley Nonpoint Source Pollution Control Program, 1995.

Coastal Nonpoint Pollution Control Program; Program Development and Approval Guidance, Working Group, Working Paper; USEPA, April 1992.

Stormwater Quality Handbooks - Construction Site Best Management Practices (BMPs) Manual, State of California Department of Transportation (Caltrans), November 2000.

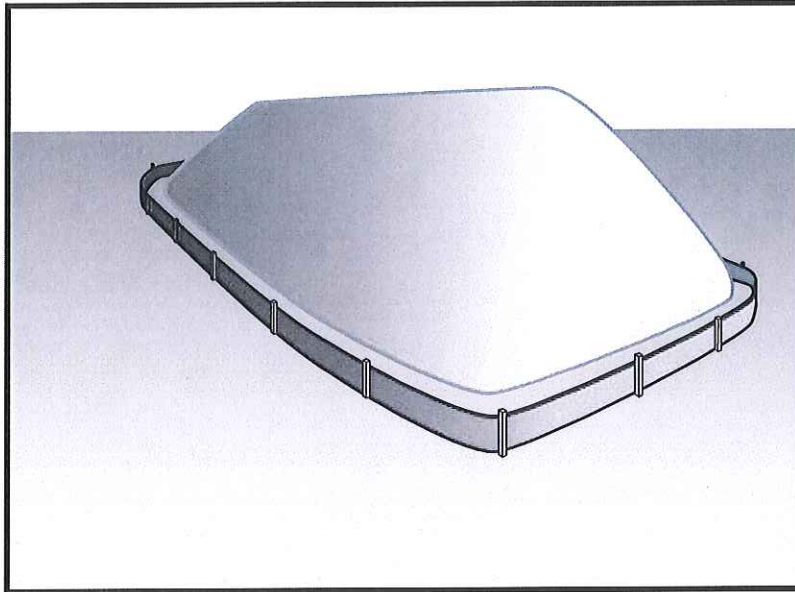

Description and Purpose

Stockpile management procedures and practices are designed to reduce or eliminate air and stormwater pollution from stockpiles of soil, soil amendments, sand, paving materials such as portland cement concrete (PCC) rubble, asphalt concrete (AC), asphalt concrete rubble, aggregate base, aggregate sub base or pre-mixed aggregate, asphalt minder (so called “cold mix” asphalt), and pressure treated wood.

Suitable Applications

Implement in all projects that stockpile soil and other loose materials.

Limitations

- Plastic sheeting as a stockpile protection is temporary and hard to manage in windy conditions. Where plastic is used, consider use of plastic tarps with nylon reinforcement which may be more durable than standard sheeting.
- Plastic sheeting can increase runoff volume due to lack of infiltration and potentially cause perimeter control failure.
- Plastic sheeting breaks down faster in sunlight.
- The use of Plastic materials and photodegradable plastics should be avoided.

Implementation

Protection of stockpiles is a year-round requirement. To properly manage stockpiles:

Categories

EC	Erosion Control	
SE	Sediment Control	<input checked="" type="checkbox"/>
TC	Tracking Control	
WE	Wind Erosion Control	
NS	Non-Stormwater Management Control	<input checked="" type="checkbox"/>
WM	Waste Management and Materials Pollution Control	<input checked="" type="checkbox"/>

Legend:

- Primary Category
- Secondary Category

Targeted Constituents

Sediment	<input checked="" type="checkbox"/>
Nutrients	<input checked="" type="checkbox"/>
Trash	<input checked="" type="checkbox"/>
Metals	<input checked="" type="checkbox"/>
Bacteria	
Oil and Grease	<input checked="" type="checkbox"/>
Organics	<input checked="" type="checkbox"/>

Potential Alternatives

None



- On larger sites, a minimum of 50 ft separation from concentrated flows of stormwater, drainage courses, and inlets is recommended.
- All stockpiles are required to be protected immediately if they are not scheduled to be used within 14 days.
- Protect all stockpiles from stormwater runoff using temporary perimeter sediment barriers such as compost berms (SE-13), temporary silt dikes (SE-12), fiber rolls (SE-5), silt fences (SE-1), sandbags (SE-8), gravel bags (SE-6), or biofilter bags (SE-14). Refer to the individual fact sheet for each of these controls for installation information.
- Implement wind erosion control practices as appropriate on all stockpiled material. For specific information, see WE-1, Wind Erosion Control.
- Manage stockpiles of contaminated soil in accordance with WM-7, Contaminated Soil Management.
- Place bagged materials on pallets and under cover.
- Ensure that stockpile coverings are installed securely to protect from wind and rain.
- Some plastic covers withstand weather and sunlight better than others. Select cover materials or methods based on anticipated duration of use.

Protection of Non-Active Stockpiles

Non-active stockpiles of the identified materials should be protected further as follows:

Soil stockpiles

- Soil stockpiles should be covered or protected with soil stabilization measures and a temporary perimeter sediment barrier at all times.
- Temporary vegetation should be considered for topsoil piles that will be stockpiled for extended periods.

Stockpiles of Portland cement concrete rubble, asphalt concrete, asphalt concrete rubble, aggregate base, or aggregate sub base

- Stockpiles should be covered and protected with a temporary perimeter sediment barrier at all times.

Stockpiles of "cold mix"

- Cold mix stockpiles should be placed on and covered with plastic sheeting or comparable material at all times and surrounded by a berm.

Stockpiles of fly ash, stucco, hydrated lime

- Stockpiles of materials that may raise the pH of runoff (i.e., basic materials) should be covered with plastic and surrounded by a berm.

Stockpiles/Storage of wood (Pressure treated with chromated copper arsenate or ammoniacal copper zinc arsenate)

- Treated wood should be covered with plastic sheeting or comparable material at all times and surrounded by a berm.

Protection of Active Stockpiles

Active stockpiles of the identified materials should be protected as follows:

- All stockpiles should be covered and protected with a temporary linear sediment barrier prior to the onset of precipitation.
- Stockpiles of “cold mix” and treated wood, and basic materials should be placed on and covered with plastic sheeting or comparable material and surrounded by a berm prior to the onset of precipitation.
- The downstream perimeter of an active stockpile should be protected with a linear sediment barrier or berm and runoff should be diverted around or away from the stockpile on the upstream perimeter.

Costs

For cost information associated with stockpile protection refer to the individual erosion or sediment control BMP fact sheet considered for implementation (For example, refer to SE-1 Silt Fence for installation of silt fence around the perimeter of a stockpile.)

Inspection and Maintenance

- Stockpiles must be inspected in accordance with General Permit requirements for the associated project type and risk level. It is recommended that at a minimum, BMPs be inspected weekly, prior to forecasted rain events, daily during extended rain events, and after the conclusion of rain events.
- It may be necessary to inspect stockpiles covered with plastic sheeting more frequently during certain conditions (for example, high winds or extreme heat).
- Repair and/or replace perimeter controls and covers as needed to keep them functioning properly.
- Sediment shall be removed when it reaches one-third of the barrier height.

References

Stormwater Quality Handbooks - Construction Site Best Management Practices (BMPs) Manual, State of California Department of Transportation (Caltrans), March 2003.

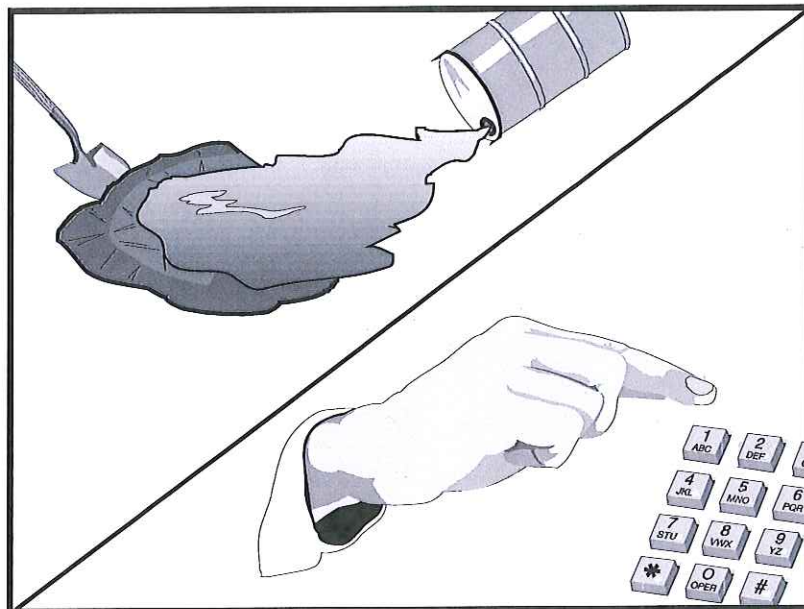

Description and Purpose

Prevent or reduce the discharge of pollutants to drainage systems or watercourses from leaks and spills by reducing the chance for spills, stopping the source of spills, containing and cleaning up spills, properly disposing of spill materials, and training employees.

This best management practice covers only spill prevention and control. However, WM-1, Materials Delivery and Storage, and WM-2, Material Use, also contain useful information, particularly on spill prevention. For information on wastes, see the waste management BMPs in this section.

Suitable Applications

This BMP is suitable for all construction projects. Spill control procedures are implemented anytime chemicals or hazardous substances are stored on the construction site, including the following materials:

- Soil stabilizers/binders
- Dust palliatives
- Herbicides
- Growth inhibitors
- Fertilizers
- Deicing/anti-icing chemicals

Categories

EC	Erosion Control	
SE	Sediment Control	
TC	Tracking Control	
WE	Wind Erosion Control	
NS	Non-Stormwater Management Control	
WM	Waste Management and Materials Pollution Control	<input checked="" type="checkbox"/>

Legend:

- Primary Objective
- Secondary Objective

Targeted Constituents

Sediment	<input checked="" type="checkbox"/>
Nutrients	<input checked="" type="checkbox"/>
Trash	<input checked="" type="checkbox"/>
Metals	<input checked="" type="checkbox"/>
Bacteria	
Oil and Grease	<input checked="" type="checkbox"/>
Organics	<input checked="" type="checkbox"/>

Potential Alternatives

None



- Fuels
- Lubricants
- Other petroleum distillates

Limitations

- In some cases it may be necessary to use a private spill cleanup company.
- This BMP applies to spills caused by the contractor and subcontractors.
- Procedures and practices presented in this BMP are general. Contractor should identify appropriate practices for the specific materials used or stored onsite

Implementation

The following steps will help reduce the stormwater impacts of leaks and spills:

Education

- Be aware that different materials pollute in different amounts. Make sure that each employee knows what a “significant spill” is for each material they use, and what is the appropriate response for “significant” and “insignificant” spills.
- Educate employees and subcontractors on potential dangers to humans and the environment from spills and leaks.
- Hold regular meetings to discuss and reinforce appropriate disposal procedures (incorporate into regular safety meetings).
- Establish a continuing education program to indoctrinate new employees.
- Have contractor’s superintendent or representative oversee and enforce proper spill prevention and control measures.

General Measures

- To the extent that the work can be accomplished safely, spills of oil, petroleum products, substances listed under 40 CFR parts 110,117, and 302, and sanitary and septic wastes should be contained and cleaned up immediately.
- Store hazardous materials and wastes in covered containers and protect from vandalism.
- Place a stockpile of spill cleanup materials where it will be readily accessible.
- Train employees in spill prevention and cleanup.
- Designate responsible individuals to oversee and enforce control measures.
- Spills should be covered and protected from stormwater runoff during rainfall to the extent that it doesn’t compromise clean up activities.
- Do not bury or wash spills with water.

- Store and dispose of used clean up materials, contaminated materials, and recovered spill material that is no longer suitable for the intended purpose in conformance with the provisions in applicable BMPs.
- Do not allow water used for cleaning and decontamination to enter storm drains or watercourses. Collect and dispose of contaminated water in accordance with WM-10, Liquid Waste Management.
- Contain water overflow or minor water spillage and do not allow it to discharge into drainage facilities or watercourses.
- Place proper storage, cleanup, and spill reporting instructions for hazardous materials stored or used on the project site in an open, conspicuous, and accessible location.
- Keep waste storage areas clean, well organized, and equipped with ample cleanup supplies as appropriate for the materials being stored. Perimeter controls, containment structures, covers, and liners should be repaired or replaced as needed to maintain proper function.

Cleanup

- Clean up leaks and spills immediately.
- Use a rag for small spills on paved surfaces, a damp mop for general cleanup, and absorbent material for larger spills. If the spilled material is hazardous, then the used cleanup materials are also hazardous and must be sent to either a certified laundry (rags) or disposed of as hazardous waste.
- Never hose down or bury dry material spills. Clean up as much of the material as possible and dispose of properly. See the waste management BMPs in this section for specific information.

Minor Spills

- Minor spills typically involve small quantities of oil, gasoline, paint, etc. which can be controlled by the first responder at the discovery of the spill.
- Use absorbent materials on small spills rather than hosing down or burying the spill.
- Absorbent materials should be promptly removed and disposed of properly.
- Follow the practice below for a minor spill:
 - Contain the spread of the spill.
 - Recover spilled materials.
 - Clean the contaminated area and properly dispose of contaminated materials.

Semi-Significant Spills

- Semi-significant spills still can be controlled by the first responder along with the aid of other personnel such as laborers and the foreman, etc. This response may require the cessation of all other activities.

- Spills should be cleaned up immediately:
 - Contain spread of the spill.
 - Notify the project foreman immediately.
 - If the spill occurs on paved or impermeable surfaces, clean up using "dry" methods (absorbent materials, cat litter and/or rags). Contain the spill by encircling with absorbent materials and do not let the spill spread widely.
 - If the spill occurs in dirt areas, immediately contain the spill by constructing an earthen dike. Dig up and properly dispose of contaminated soil.
 - If the spill occurs during rain, cover spill with tarps or other material to prevent contaminating runoff.

Significant/Hazardous Spills

- For significant or hazardous spills that cannot be controlled by personnel in the immediate vicinity, the following steps should be taken:
 - Notify the local emergency response by dialing 911. In addition to 911, the contractor will notify the proper county officials. It is the contractor's responsibility to have all emergency phone numbers at the construction site.
 - Notify the Governor's Office of Emergency Services Warning Center, (916) 845-8911.
 - For spills of federal reportable quantities, in conformance with the requirements in 40 CFR parts 110,119, and 302, the contractor should notify the National Response Center at (800) 424-8802.
 - Notification should first be made by telephone and followed up with a written report.
 - The services of a spills contractor or a Haz-Mat team should be obtained immediately. Construction personnel should not attempt to clean up until the appropriate and qualified staffs have arrived at the job site.
 - Other agencies which may need to be consulted include, but are not limited to, the Fire Department, the Public Works Department, the Coast Guard, the Highway Patrol, the City/County Police Department, Department of Toxic Substances, California Division of Oil and Gas, Cal/OSHA, etc.

Reporting

- Report significant spills to local agencies, such as the Fire Department; they can assist in cleanup.
- Federal regulations require that any significant oil spill into a water body or onto an adjoining shoreline be reported to the National Response Center (NRC) at 800-424-8802 (24 hours).

Use the following measures related to specific activities:

Vehicle and Equipment Maintenance

- If maintenance must occur onsite, use a designated area and a secondary containment, located away from drainage courses, to prevent the runoff of stormwater and the runoff of spills.
- Regularly inspect onsite vehicles and equipment for leaks and repair immediately
- Check incoming vehicles and equipment (including delivery trucks, and employee and subcontractor vehicles) for leaking oil and fluids. Do not allow leaking vehicles or equipment onsite.
- Always use secondary containment, such as a drain pan or drop cloth, to catch spills or leaks when removing or changing fluids.
- Place drip pans or absorbent materials under paving equipment when not in use.
- Use absorbent materials on small spills rather than hosing down or burying the spill. Remove the absorbent materials promptly and dispose of properly.
- Promptly transfer used fluids to the proper waste or recycling drums. Don't leave full drip pans or other open containers lying around
- Oil filters disposed of in trashcans or dumpsters can leak oil and pollute stormwater. Place the oil filter in a funnel over a waste oil-recycling drum to drain excess oil before disposal. Oil filters can also be recycled. Ask the oil supplier or recycler about recycling oil filters.
- Store cracked batteries in a non-leaking secondary container. Do this with all cracked batteries even if you think all the acid has drained out. If you drop a battery, treat it as if it is cracked. Put it into the containment area until you are sure it is not leaking.

Vehicle and Equipment Fueling

- If fueling must occur onsite, use designate areas, located away from drainage courses, to prevent the runoff of stormwater and the runoff of spills.
- Discourage "topping off" of fuel tanks.
- Always use secondary containment, such as a drain pan, when fueling to catch spills/ leaks.

Costs

Prevention of leaks and spills is inexpensive. Treatment and/ or disposal of contaminated soil or water can be quite expensive.

Inspection and Maintenance

- Inspect and verify that activity-based BMPs are in place prior to the commencement of associated activities. While activities associated with the BMP are under way, inspect weekly during the rainy season and of two-week intervals in the non-rainy season to verify continued BMP implementation.
- Inspect BMPs subject to non-stormwater discharge daily while non-stormwater discharges occur.

- Keep ample supplies of spill control and cleanup materials onsite, near storage, unloading, and maintenance areas.
- Update your spill prevention and control plan and stock cleanup materials as changes occur in the types of chemicals onsite.

References

Blueprint for a Clean Bay: Best Management Practices to Prevent Stormwater Pollution from Construction Related Activities; Santa Clara Valley Nonpoint Source Pollution Control Program, 1995.

Stormwater Quality Handbooks - Construction Site Best Management Practices (BMPs) Manual, State of California Department of Transportation (Caltrans), November 2000.

Stormwater Management for Construction Activities; Developing Pollution Prevention Plans and Best Management Practice, EPA 832-R-92005; USEPA, April 1992.

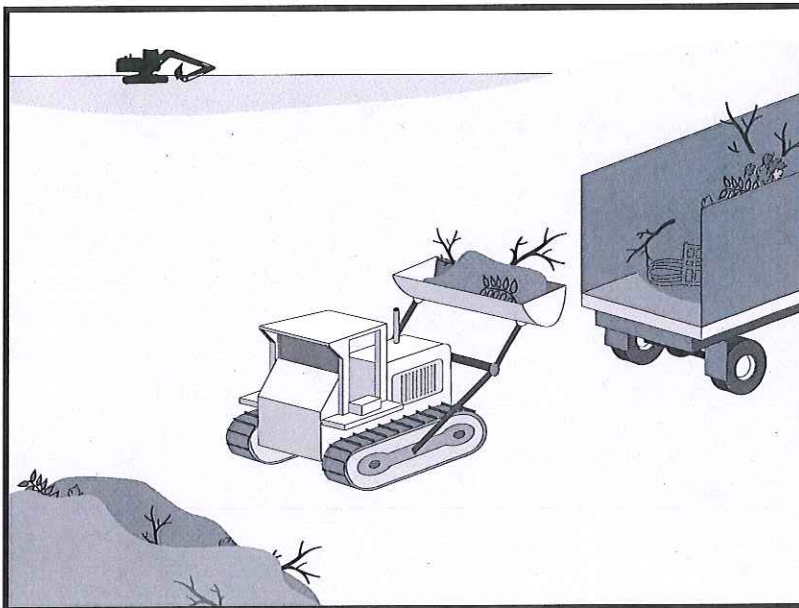

Description and Purpose

Solid waste management procedures and practices are designed to prevent or reduce the discharge of pollutants to stormwater from solid or construction waste by providing designated waste collection areas and containers, arranging for regular disposal, and training employees and subcontractors.

Suitable Applications

This BMP is suitable for construction sites where the following wastes are generated or stored:

- Solid waste generated from trees and shrubs removed during land clearing, demolition of existing structures (rubble), and building construction
- Packaging materials including wood, paper, and plastic
- Scrap or surplus building materials including scrap metals, rubber, plastic, glass pieces and masonry products
- Domestic wastes including food containers such as beverage cans, coffee cups, paper bags, plastic wrappers, and cigarettes
- Construction wastes including brick, mortar, timber, steel and metal scraps, pipe and electrical cuttings, non-hazardous equipment parts, styrofoam and other materials used to transport and package construction materials
- Highway planting wastes, including vegetative material,

Categories

EC	Erosion Control	
SE	Sediment Control	
TC	Tracking Control	
WE	Wind Erosion Control	
NS	Non-Stormwater Management Control	
WM	Waste Management and Materials Pollution Control	<input checked="" type="checkbox"/>

Legend:

- Primary Objective
- Secondary Objective

Targeted Constituents

Sediment	<input checked="" type="checkbox"/>
Nutrients	<input checked="" type="checkbox"/>
Trash	<input checked="" type="checkbox"/>
Metals	<input checked="" type="checkbox"/>
Bacteria	
Oil and Grease	<input checked="" type="checkbox"/>
Organics	<input checked="" type="checkbox"/>

Potential Alternatives

None



plant containers, and packaging materials

Limitations

Temporary stockpiling of certain construction wastes may not necessitate stringent drainage related controls during the non-rainy season or in desert areas with low rainfall.

Implementation

The following steps will help keep a clean site and reduce stormwater pollution:

- Select designated waste collection areas onsite.
- Inform trash-hauling contractors that you will accept only watertight dumpsters for onsite use. Inspect dumpsters for leaks and repair any dumpster that is not watertight.
- Locate containers in a covered area or in a secondary containment.
- Provide an adequate number of containers with lids or covers that can be placed over the container to keep rain out or to prevent loss of wastes when it is windy.
- Plan for additional containers and more frequent pickup during the demolition phase of construction.
- Collect site trash daily, especially during rainy and windy conditions.
- Remove this solid waste promptly since erosion and sediment control devices tend to collect litter.
- Make sure that toxic liquid wastes (used oils, solvents, and paints) and chemicals (acids, pesticides, additives, curing compounds) are not disposed of in dumpsters designated for construction debris.
- Do not hose out dumpsters on the construction site. Leave dumpster cleaning to the trash hauling contractor.
- Arrange for regular waste collection before containers overflow.
- Clean up immediately if a container does spill.
- Make sure that construction waste is collected, removed, and disposed of only at authorized disposal areas.

Education

- Have the contractor's superintendent or representative oversee and enforce proper solid waste management procedures and practices.
- Instruct employees and subcontractors on identification of solid waste and hazardous waste.
- Educate employees and subcontractors on solid waste storage and disposal procedures.
- Hold regular meetings to discuss and reinforce disposal procedures (incorporate into regular safety meetings).

- Require that employees and subcontractors follow solid waste handling and storage procedures.
- Prohibit littering by employees, subcontractors, and visitors.
- Minimize production of solid waste materials wherever possible.

Collection, Storage, and Disposal

- Littering on the project site should be prohibited.
- To prevent clogging of the storm drainage system, litter and debris removal from drainage grates, trash racks, and ditch lines should be a priority.
- Trash receptacles should be provided in the contractor's yard, field trailer areas, and at locations where workers congregate for lunch and break periods.
- Litter from work areas within the construction limits of the project site should be collected and placed in watertight dumpsters at least weekly, regardless of whether the litter was generated by the contractor, the public, or others. Collected litter and debris should not be placed in or next to drain inlets, stormwater drainage systems, or watercourses.
- Dumpsters of sufficient size and number should be provided to contain the solid waste generated by the project.
- Full dumpsters should be removed from the project site and the contents should be disposed of by the trash hauling contractor.
- Construction debris and waste should be removed from the site biweekly or more frequently as needed.
- Construction material visible to the public should be stored or stacked in an orderly manner.
- Stormwater runoff should be prevented from contacting stored solid waste through the use of berms, dikes, or other temporary diversion structures or through the use of measures to elevate waste from site surfaces.
- Solid waste storage areas should be located at least 50 ft from drainage facilities and watercourses and should not be located in areas prone to flooding or ponding.
- Except during fair weather, construction and highway planting waste not stored in watertight dumpsters should be securely covered from wind and rain by covering the waste with tarps or plastic.
- Segregate potentially hazardous waste from non-hazardous construction site waste.
- Make sure that toxic liquid wastes (used oils, solvents, and paints) and chemicals (acids, pesticides, additives, curing compounds) are not disposed of in dumpsters designated for construction debris.
- For disposal of hazardous waste, see WM-6, Hazardous Waste Management. Have hazardous waste hauled to an appropriate disposal and/or recycling facility.

- Salvage or recycle useful vegetation debris, packaging and surplus building materials when practical. For example, trees and shrubs from land clearing can be used as a brush barrier, or converted into wood chips, then used as mulch on graded areas. Wood pallets, cardboard boxes, and construction scraps can also be recycled.

Costs

All of the above are low cost measures.

Inspection and Maintenance

- Inspect and verify that activity-based BMPs are in place prior to the commencement of associated activities. While activities associated with the BMP are under way, inspect weekly during the rainy season and of two-week intervals in the non-rainy season to verify continued BMP implementation.
- Inspect BMPs subject to non-stormwater discharge daily while non-stormwater discharges occur
- Inspect construction waste area regularly.
- Arrange for regular waste collection.

References

Processes, Procedures and Methods to Control Pollution Resulting from All Construction Activity, 430/9-73-007, USEPA, 1973.

Stormwater Quality Handbooks - Construction Site Best Management Practices (BMPs) Manual, State of California Department of Transportation (Caltrans), November 2000.

Stormwater Management for Construction Activities; Developing Pollution Prevention Plans and Best Management Practice, EPA 832-R-92005; USEPA, April 1992.

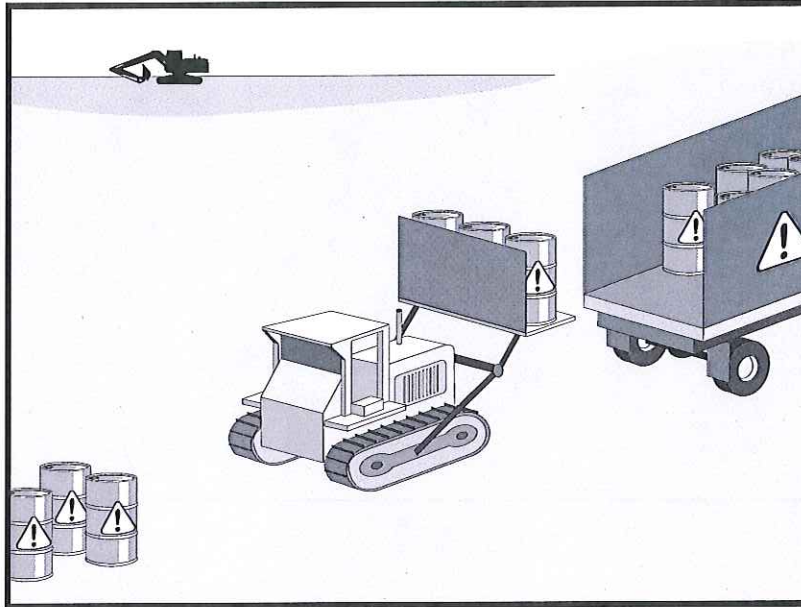

Categories

EC	Erosion Control	
SE	Sediment Control	
TC	Tracking Control	
WE	Wind Erosion Control	
NS	Non-Stormwater Management Control	
WM	Waste Management and Materials Pollution Control	<input checked="" type="checkbox"/>

Legend:

- Primary Objective
- Secondary Objective

Description and Purpose

Prevent or reduce the discharge of pollutants to stormwater from hazardous waste through proper material use, waste disposal, and training of employees and subcontractors.

Suitable Applications

This best management practice (BMP) applies to all construction projects. Hazardous waste management practices are implemented on construction projects that generate waste from the use of:

- Petroleum Products
- Concrete Curing Compounds
- Palliatives
- Septic Wastes
- Stains
- Wood Preservatives
- Asphalt Products
- Pesticides
- Acids
- Paints
- Solvents
- Roofing Tar
- Any materials deemed a hazardous waste in California, Title 22 Division 4.5, or listed in 40 CFR Parts 110, 117, 261, or 302

Targeted Constituents

Sediment	
Nutrients	<input checked="" type="checkbox"/>
Trash	<input checked="" type="checkbox"/>
Metals	<input checked="" type="checkbox"/>
Bacteria	<input checked="" type="checkbox"/>
Oil and Grease	<input checked="" type="checkbox"/>
Organics	<input checked="" type="checkbox"/>

Potential Alternatives

None



In addition, sites with existing structures may contain wastes, which must be disposed of in accordance with federal, state, and local regulations. These wastes include:

- Sandblasting grit mixed with lead-, cadmium-, or chromium-based paints
- Asbestos
- PCBs (particularly in older transformers)

Limitations

- Hazardous waste that cannot be reused or recycled must be disposed of by a licensed hazardous waste hauler.
- Nothing in this BMP relieves the contractor from responsibility for compliance with federal, state, and local laws regarding storage, handling, transportation, and disposal of hazardous wastes.
- This BMP does not cover aerially deposited lead (ADL) soils. For ADL soils refer to WM-7, Contaminated Soil Management.

Implementation

The following steps will help reduce stormwater pollution from hazardous wastes:

Material Use

- Wastes should be stored in sealed containers constructed of a suitable material and should be labeled as required by Title 22 CCR, Division 4.5 and 49 CFR Parts 172, 173, 178, and 179.
- All hazardous waste should be stored, transported, and disposed as required in Title 22 CCR, Division 4.5 and 49 CFR 261-263.
- Waste containers should be stored in temporary containment facilities that should comply with the following requirements:
 - Temporary containment facility should provide for a spill containment volume equal to 1.5 times the volume of all containers able to contain precipitation from a 25 year storm event, plus the greater of 10% of the aggregate volume of all containers or 100% of the capacity of the largest tank within its boundary, whichever is greater.
 - Temporary containment facility should be impervious to the materials stored there for a minimum contact time of 72 hours.
 - Temporary containment facilities should be maintained free of accumulated rainwater and spills. In the event of spills or leaks, accumulated rainwater and spills should be placed into drums after each rainfall. These liquids should be handled as a hazardous waste unless testing determines them to be non-hazardous. Non-hazardous liquids should be sent to an approved disposal site.
 - Sufficient separation should be provided between stored containers to allow for spill cleanup and emergency response access.

- Incompatible materials, such as chlorine and ammonia, should not be stored in the same temporary containment facility.
- Throughout the rainy season, temporary containment facilities should be covered during non-working days, and prior to rain events. Covered facilities may include use of plastic tarps for small facilities or constructed roofs with overhangs.
- Drums should not be overfilled and wastes should not be mixed.
- Unless watertight, containers of dry waste should be stored on pallets.
- Do not over-apply herbicides and pesticides. Prepare only the amount needed. Follow the recommended usage instructions. Over application is expensive and environmentally harmful. Apply surface dressings in several smaller applications, as opposed to one large application. Allow time for infiltration and avoid excess material being carried offsite by runoff. Do not apply these chemicals just before it rains. People applying pesticides must be certified in accordance with federal and state regulations.
- Paint brushes and equipment for water and oil based paints should be cleaned within a contained area and should not be allowed to contaminate site soils, watercourses, or drainage systems. Waste paints, thinners, solvents, residues, and sludges that cannot be recycled or reused should be disposed of as hazardous waste. When thoroughly dry, latex paint and paint cans, used brushes, rags, absorbent materials, and drop cloths should be disposed of as solid waste.
- Do not clean out brushes or rinse paint containers into the dirt, street, gutter, storm drain, or stream. "Paint out" brushes as much as possible. Rinse water-based paints to the sanitary sewer. Filter and reuse thinners and solvents. Dispose of excess oil-based paints and sludge as hazardous waste.
- The following actions should be taken with respect to temporary contaminant:
 - Ensure that adequate hazardous waste storage volume is available.
 - Ensure that hazardous waste collection containers are conveniently located.
 - Designate hazardous waste storage areas onsite away from storm drains or watercourses and away from moving vehicles and equipment to prevent accidental spills.
 - Minimize production or generation of hazardous materials and hazardous waste on the job site.
 - Use containment berms in fueling and maintenance areas and where the potential for spills is high.
 - Segregate potentially hazardous waste from non-hazardous construction site debris.
 - Keep liquid or semi-liquid hazardous waste in appropriate containers (closed drums or similar) and under cover.

- Clearly label all hazardous waste containers with the waste being stored and the date of accumulation.
- Place hazardous waste containers in secondary containment.
- Do not allow potentially hazardous waste materials to accumulate on the ground.
- Do not mix wastes.
- Use all of the product before disposing of the container.
- Do not remove the original product label; it contains important safety and disposal information.

Waste Recycling Disposal

- Select designated hazardous waste collection areas onsite.
- Hazardous materials and wastes should be stored in covered containers and protected from vandalism.
- Place hazardous waste containers in secondary containment.
- Do not mix wastes, this can cause chemical reactions, making recycling impossible and complicating disposal.
- Recycle any useful materials such as used oil or water-based paint.
- Make sure that toxic liquid wastes (used oils, solvents, and paints) and chemicals (acids, pesticides, additives, curing compounds) are not disposed of in dumpsters designated for construction debris.
- Arrange for regular waste collection before containers overflow.
- Make sure that hazardous waste (e.g., excess oil-based paint and sludge) is collected, removed, and disposed of only at authorized disposal areas.

Disposal Procedures

- Waste should be disposed of by a licensed hazardous waste transporter at an authorized and licensed disposal facility or recycling facility utilizing properly completed Uniform Hazardous Waste Manifest forms.
- A Department of Health Services certified laboratory should sample waste to determine the appropriate disposal facility.
- Properly dispose of rainwater in secondary containment that may have mixed with hazardous waste.
- Attention is directed to "Hazardous Material", "Contaminated Material", and "Aerially Deposited Lead" of the contract documents regarding the handling and disposal of hazardous materials.

Education

- Educate employees and subcontractors on hazardous waste storage and disposal procedures.
- Educate employees and subcontractors on potential dangers to humans and the environment from hazardous wastes.
- Instruct employees and subcontractors on safety procedures for common construction site hazardous wastes.
- Instruct employees and subcontractors in identification of hazardous and solid waste.
- Hold regular meetings to discuss and reinforce hazardous waste management procedures (incorporate into regular safety meetings).
- The contractor's superintendent or representative should oversee and enforce proper hazardous waste management procedures and practices.
- Make sure that hazardous waste is collected, removed, and disposed of only at authorized disposal areas.
- Warning signs should be placed in areas recently treated with chemicals.
- Place a stockpile of spill cleanup materials where it will be readily accessible.
- If a container does spill, clean up immediately.

Costs

All of the above are low cost measures.

Inspection and Maintenance

- Inspect and verify that activity-based BMPs are in place prior to the commencement of associated activities. While activities associated with the BMP are under way, inspect weekly during the rainy season and of two week intervals in the non-rainy season to verify continued BMP implementation.
- Inspect BMPs subject to non-stormwater discharge daily while non-stormwater discharges occur
- Hazardous waste should be regularly collected.
- A foreman or construction supervisor should monitor onsite hazardous waste storage and disposal procedures.
- Waste storage areas should be kept clean, well organized, and equipped with ample cleanup supplies as appropriate for the materials being stored.
- Perimeter controls, containment structures, covers, and liners should be repaired or replaced as needed to maintain proper function.
- Hazardous spills should be cleaned up and reported in conformance with the applicable Material Safety Data Sheet (MSDS) and the instructions posted at the project site.

- The National Response Center, at (800) 424-8802, should be notified of spills of federal reportable quantities in conformance with the requirements in 40 CFR parts 110, 117, and 302. Also notify the Governor's Office of Emergency Services Warning Center at (916) 845-8911.
- A copy of the hazardous waste manifests should be provided.

References

Blueprint for a Clean Bay: Best Management Practices to Prevent Stormwater Pollution from Construction Related Activities; Santa Clara Valley Nonpoint Source Pollution Control Program, 1995.

Processes, Procedures and Methods to Control Pollution Resulting from All Construction Activity, 430/9-73-007, USEPA, 1973.

Stormwater Quality Handbooks - Construction Site Best Management Practices (BMPs) Manual, State of California Department of Transportation (Caltrans), November 2000.

Stormwater Management for Construction Activities; Developing Pollution Prevention Plans and Best Management Practice, EPA 832-R-92005; USEPA, April 1992.

Sanitary/Septic Waste Management WM-9

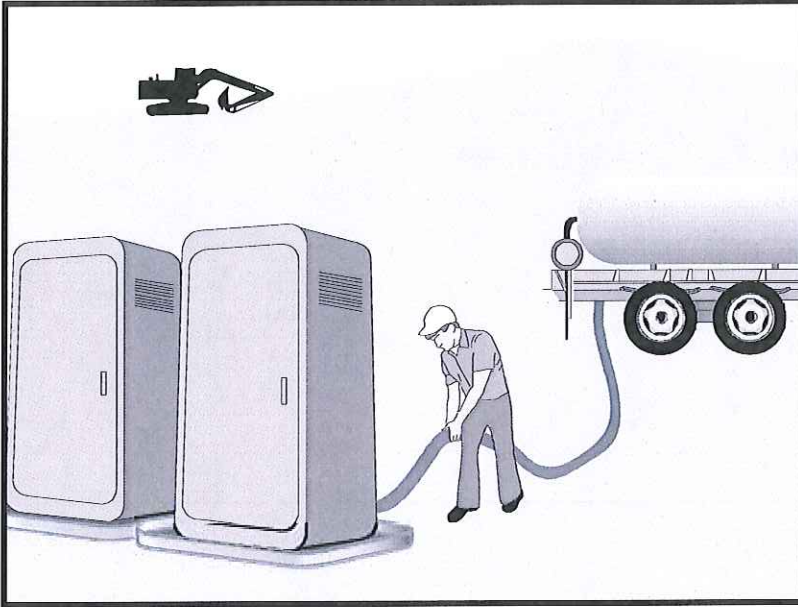

Description and Purpose

Proper sanitary and septic waste management prevent the discharge of pollutants to stormwater from sanitary and septic waste by providing convenient, well-maintained facilities, and arranging for regular service and disposal.

Suitable Applications

Sanitary septic waste management practices are suitable for use at all construction sites that use temporary or portable sanitary and septic waste systems.

Limitations

None identified.

Implementation

Sanitary or septic wastes should be treated or disposed of in accordance with state and local requirements. In many cases, one contract with a local facility supplier will be all that it takes to make sure sanitary wastes are properly disposed.

Storage and Disposal Procedures

- Temporary sanitary facilities should be located away from drainage facilities, watercourses, and from traffic circulation. If site conditions allow, place portable facilities a minimum of 50 feet from drainage conveyances and traffic areas. When subjected to high winds or risk of high winds, temporary sanitary facilities should be secured to prevent overturning.

Categories

EC	Erosion Control	
SE	Sediment Control	
TC	Tracking Control	
WE	Wind Erosion Control	
NS	Non-Stormwater Management Control	
WM	Waste Management and Materials Pollution Control	<input checked="" type="checkbox"/>

Legend:

- Primary Category
- Secondary Category

Targeted Constituents

Sediment	
Nutrients	<input checked="" type="checkbox"/>
Trash	<input checked="" type="checkbox"/>
Metals	
Bacteria	<input checked="" type="checkbox"/>
Oil and Grease	
Organics	<input checked="" type="checkbox"/>

Potential Alternatives

None



Sanitary/Septic Waste Management WM-9

- Temporary sanitary facilities must be equipped with containment to prevent discharge of pollutants to the stormwater drainage system of the receiving water.
- Consider safety as well as environmental implications before placing temporary sanitary facilities.
- Wastewater should not be discharged or buried within the project site.
- Sanitary and septic systems that discharge directly into sanitary sewer systems, where permissible, should comply with the local health agency, city, county, and sewer district requirements.
- Only reputable, licensed sanitary and septic waste haulers should be used.
- Sanitary facilities should be located in a convenient location.
- Temporary septic systems should treat wastes to appropriate levels before discharging.
- If using an onsite disposal system (OSDS), such as a septic system, local health agency requirements must be followed.
- Temporary sanitary facilities that discharge to the sanitary sewer system should be properly connected to avoid illicit discharges.
- Sanitary and septic facilities should be maintained in good working order by a licensed service.
- Regular waste collection by a licensed hauler should be arranged before facilities overflow.
- If a spill does occur from a temporary sanitary facility, follow federal, state and local regulations for containment and clean-up.

Education

- Educate employees, subcontractors, and suppliers on sanitary and septic waste storage and disposal procedures.
- Educate employees, subcontractors, and suppliers of potential dangers to humans and the environment from sanitary and septic wastes.
- Instruct employees, subcontractors, and suppliers in identification of sanitary and septic waste.
- Hold regular meetings to discuss and reinforce the use of sanitary facilities (incorporate into regular safety meetings).
- Establish a continuing education program to indoctrinate new employees.

Costs

All of the above are low cost measures.

Sanitary/Septic Waste Management WM-9

Inspection and Maintenance

- BMPs must be inspected in accordance with General Permit requirements for the associated project type and risk level. It is recommended that at a minimum, BMPs be inspected weekly, prior to forecasted rain events, daily during extended rain events, and after the conclusion of rain events.
- Arrange for regular waste collection.
- If high winds are expected, portable sanitary facilities must be secured with spikes or weighed down to prevent over turning.
- If spills or leaks from sanitary or septic facilities occur that are not contained and discharge from the site, non-visible sampling of site discharge may be required. Refer to the General Permit or to your project specific Construction Site Monitoring Plan to determine if and where sampling is required.

References

Stormwater Quality Handbooks - Construction Site Best Management Practices (BMPs) Manual, State of California Department of Transportation (Caltrans), March 2003.

Stormwater Management for Construction Activities; Developing Pollution Prevention Plans and Best Management Practice, EPA 832-R-92005; USEPA, April 1992.

APPENDIX E

Spill Contingency and Accidental Discharge and Contingency Plan

SSFL Facility Spill Prevention and Response Plan

**The Boeing Company - SSFL
5800 Woolsey Canyon Road
Simi Valley, California 93063**

**Boeing Company
Santa Susana Field Laboratory
5800 Woolsey Canyon Road
Simi Valley, CA 93063**

SSFL FACILITY

Spill Prevention and Response Plan

(Part of the “SSFL Hazardous Materials Release Response, Business Plan, and Inventory”)

**IN THE EVENT OF AN ACTUAL OR POTENTIAL
HAZARDOUS SUBSTANCE SPILL, REFER TO
FOLLOWING SECTIONS OF THIS DOCUMENT:**

- TABLE 7.1 "Emergency Response Checklist"
- TABLE 7.2 "Emergency Response Contacts"
- SPRP APPENDIX B "Notification Procedures for Environmental Regulatory Agencies"
- Section 7.2.1 "Radioactive Materials Handling Facility (RMHF)"

**Revision 15
March 2012**

Contents

1.0	FACILITY INFORMATION	1
1.1	Facility Name.....	1
1.2	Facility Location	1
1.3	Principal Business Activity.....	1
1.4	Facility Owner	1
1.5	Designated Incident Commander (IC)	1
1.5.1	Primary	1
1.5.2	Alternate Incident Commander.....	2
2.0	CERTIFICATION	3
3.0	RECORD OF CHANGES AND REVIEWS	4
3.1	Plan Changes.....	4
3.2	Plan Review	4
4.0	SITE DESCRIPTION	5
4.1	General Description of Facilities at SSFL	5
4.2	General Description of Hydrology.....	11
4.2.1	Surface Water	11
4.2.2	Groundwater	11
4.3	Topography/Geology	12
4.3.1	Topography.....	12
4.3.2	Geology.....	12
4.4	Spill Events	13
5.0	SPILL PREVENTION AND RESPONSE PLAN.....	14
5.1	Purpose.....	14
5.2	Goal.....	14
5.3	Objectives	14
5.4	Scope.....	14
5.5	Regulatory Overview	14
5.5.1	Federal	14
5.5.2	State	15
5.5.3	Local	15

Contents

5.6	Policies	15
5.6.1	Oil	15
5.6.2	Hazardous Substances	15
5.6.3	Pollution Control	16
5.6.4	Plan Responsibility (Updates/Implementation).....	16
6.0	SPILL PREVENTION CONTROL AND COUNTERMEASURES	17
6.1	Introduction.....	17
6.2	Oil and Hazardous Substances.....	17
6.2.1	Inventory.....	17
6.2.2	Material Safety Data Sheets.....	17
6.3	Oil And Hazardous Materials Handling Areas	17
6.4	Identification of Potential Spill Sites	17
6.5	Spill Response Equipment	17
6.6	Oil and Hazardous Substances - Spill Prevention.....	18
6.6.1	General Procedures	18
6.6.2	Oil, Fuel, and Hazardous Materials Storage.....	19
6.6.3	Drums and Small Containers.....	20
6.6.4	Transfer of Oil and Hazardous Substances within SSFL	20
6.6.5	Truck Loading/Unloading of Oil and Hazardous Substances	20
6.6.6	Degreasers.....	21
6.7	Oil and Hazardous Substances Storage Inspections	21
6.7.1	Aboveground Storage Tank Inspection	21
6.7.2	Underground Storage Tank (UST) Inspection.....	21
6.8	Spill Prevention Responsibilities	21
6.8.1	Boeing Employees	21
6.8.2	Functional Management	22
6.8.3	Incident Commander or Delegate (Security & Fire Protection).....	22
6.8.4	Environment, Health and Safety (EHS).....	22
6.8.5	Site Services.....	23
6.8.6	Contractors.....	23
6.9	Documentation	23

Contents

6.9.1	SPRP	23
6.9.2	Inspection Reports	23
6.9.3	Spill Documentation	23
6.10	Periodic Drills	23
6.11	Security	24
6.12	Employee Training Plan	24
6.12.1	Training Documentation	25
7.0	CONTINGENCY PLAN	26
7.1	Introduction.....	26
7.2	Scope.....	26
7.2.1	Radioactive Materials Handling Facility (RMHF)	26
7.3	Spill Discovery.....	27
7.3.1	Initial Discovery	27
7.3.2	Initial Notification	29
7.4	Initial Response.....	29
7.5	Evaluation and Initiation of Response Action	29
7.5.1	Spill Control Team	29
7.5.2	Non-Boeing Aid.....	30
7.5.3	Material Identification	31
7.5.4	Assessment of Health Effects	31
7.5.5	Off-site Health Threat.....	32
7.5.6	Evacuations.....	32
7.5.7	Shelter in Place	32
7.5.8	Notifications	32
7.6	Containment and Countermeasures	32
7.7	Cleanup, Disposal, and Restoration	33
7.7.1	Cleanup	33
7.7.2	Disposal	33
7.7.3	Restoration.....	33
7.8	Follow-up.....	33
7.8.1	Release of Area.....	33

Contents

7.8.2	Written/Follow-up Notifications	33
7.8.3	Spill Control Team Review/Written Report	33
7.9	Earthquakes	34
8.0	CERTIFICATION OF APPLICABILITY OF SUBSTANTIAL HARM CRITERIA....	35
	APPENDIX A BOEING EMERGENCY RESPONSE EQUIPMENT.....	36
	APPENDIX B NOTIFICATION PROCEDURES FOR ENVIRONMENTAL REGULATORY AGENCIES	39

TABLES

Table 7-1	Emergency Response Checklist	27
Table 7-2	Emergency Response Contacts.....	31

FIGURES

Figure 4.1.	SSFL Vicinity Map.....	6
Figure 4.2.	SSFL Site Map	7-9
Figure 4.3.	Storm Water Drainage Systems and Outfall Locations	10
Figure 7-1.	Emergency Assembly Areas	28

1.0 FACILITY INFORMATION

1.1 FACILITY NAME

The Boeing Company
Santa Susana Field Laboratory (SSFL)

1.2 FACILITY LOCATION

5800 Woolsey Canyon Road
Simi Valley, CA 93063

Mailing Address: c/o Paul Costa
Manager, Environmental Protection
The Boeing Company – SSFL
5800 Woolsey Canyon Road
Canoga Park, CA 91304

Contact: Paul Costa
Manager, Environmental Protection
(818) 466-8778 - Office
(818) 585-0005 - Cell

1.3 PRINCIPAL BUSINESS ACTIVITY

This facility is undergoing demolition and remediation activity. No production, testing, or research activity is being conducted at the site.

1.4 FACILITY OWNER

The Boeing Company
100 North Riverside
Chicago, Illinois 60606-1596

(Note: Area 2 and 40 acres of Area 1 at the SSFL site are owned by the National Aeronautics and Space Administration)

1.5 DESIGNATED INCIDENT COMMANDER (IC)

1.5.1 Primary

Ed Walsh
Supervisor, Security & Fire Protection

Business Address:
The Boeing Company – SSFL
5800 Woolsey Canyon Road
Simi Valley, CA 93063

Mailing Address:
The Boeing Company – SSFL

5800 Woolsey Canyon Road
Canoga Park, CA 91304

Telephone: (818) 466-8108
(562) 797-2553 (24-hour phone)

1.5.2 Alternate Incident Commander

Larry Rodman
Regional Fire Protection Engineer

Business Address:
The Boeing Company – SSFL
5800 Woolsey Canyon Road
Simi Valley, CA 93063

Mailing Address:
The Boeing Company – SSFL
5800 Woolsey Canyon Road
Canoga Park, CA 91304

Telephone: (818) 519-9886
(562) 797-2553 (24-hour phone)

2.0 CERTIFICATION

Company: The Boeing Company, Santa Susana Field Laboratory (SSFL)
Location: 5800 Woolsey Canyon Road, Simi Valley, CA 93063

SPILL PREVENTION AND RESPONSE PLAN CERTIFICATION

I hereby certify and attest that I am familiar with the facilities and the information contained in this plan and that to the best of my knowledge and belief, such information is true, complete, and accurate. Further, this plan has been prepared in accordance with pertinent federal, state, and local laws and regulations and also represents good engineering practice.

John R. Scott

Professional Engineer

54592

Registration Number



Signature

3/28/12

Date

3.0 RECORD OF CHANGES AND REVIEWS

3.1 PLAN CHANGES

Revision Number	Date	Revised By
11	April 26, 2006	Kim Tavasoli
12	December 20, 2006	Tom Venable
13	January 25, 2008	Tom Venable
14	February 12, 2010	Tom Venable
15	March 19, 2012	Tom Venable

3.2 PLAN REVIEW

Rev. No.	Reviewed By	Title	Signature	Date
15	Ed Walsh	SdFP		3/20/12

4.0 SITE DESCRIPTION

4.1 GENERAL DESCRIPTION OF FACILITIES AT SSFL

The Santa Susana Field Laboratory (SSFL) is located in the Simi Hills, a largely undeveloped area in the southeastern region of Ventura County, California (refer to Figure 4.1, SSFL Vicinity Map). The location is bordered on the east by the San Fernando Valley (City and County of Los Angeles), on the south by the Bell Canyon Estates in Ventura County, on the west by the Conejo Valley (City of Thousand Oaks in Ventura County), and on the north by the Simi Valley (City of Simi Valley in Ventura County).

SSFL occupies 2,850 acres of Company-owned and Federal Government-owned land. The site is divided into four main facility areas (Areas I, II, III, and IV) and two undeveloped areas located to the south and the north of the main facility (refer to Figure 4.2, SSFL Site Map). Area I, Area III, Area IV, and the undeveloped areas are owned and operated by The Boeing Company. A 42-acre portion of Area I and all of Area II are owned by the US Government and administered by the National Aeronautics and Space Administration (NASA). Boeing continues to provide some site support to these NASA owned areas. Area IV is owned by Boeing and consists of 290-acres, 90-acres of which are subject to Department of Energy (DOE) clean-up activities under the direction of the US EPA, the California Department of Toxic Substances Control, and the California State Water Resources Control Board.

A centralized Groundwater Extraction and Treatment System (GETS) has been constructed in Area I to treat groundwater extracted from wells installed at various SSFL locations. The Ventura County Environmental Health Division and the California Department of Toxic Substances Control have agreed that The Area I GETS will operate under the "Permit by Rule" provision of Title 22, California Code of Regulations. Spent treatment media is managed as F-listed hazardous waste.

Two large stormwater treatment facilities have been constructed. Storm Water Treatment System 11 is associated with Outfall 11 in the southcentral region of SSFL. Storm Water Treatment System 18 is associated with Outfall 18 toward the southwest region of SSFL. Both systems treat only non-hazardous stormwater to meet NPDES discharge limits.

Much of the site is being dismantled, and considerable progress has been made in removing many of the previously existing buildings, structures, and chemical storage vessels. Demolition work has been accompanied by a substantial reduction in the number of locations where hazardous materials and petroleum products are used or stored, as well as in the quantity of these materials on-site. Hazardous wastes continue to be generated, especially demolition rubble contaminated with regulated metals and occasional organics. Large volumes of soil bearing regulated metals and organics, and groundwater with trace concentrations of F-listed solvents, are generated during remediation and demolition support activities.



FIGURE 4.1

SSFL
Vicinity
Map

S

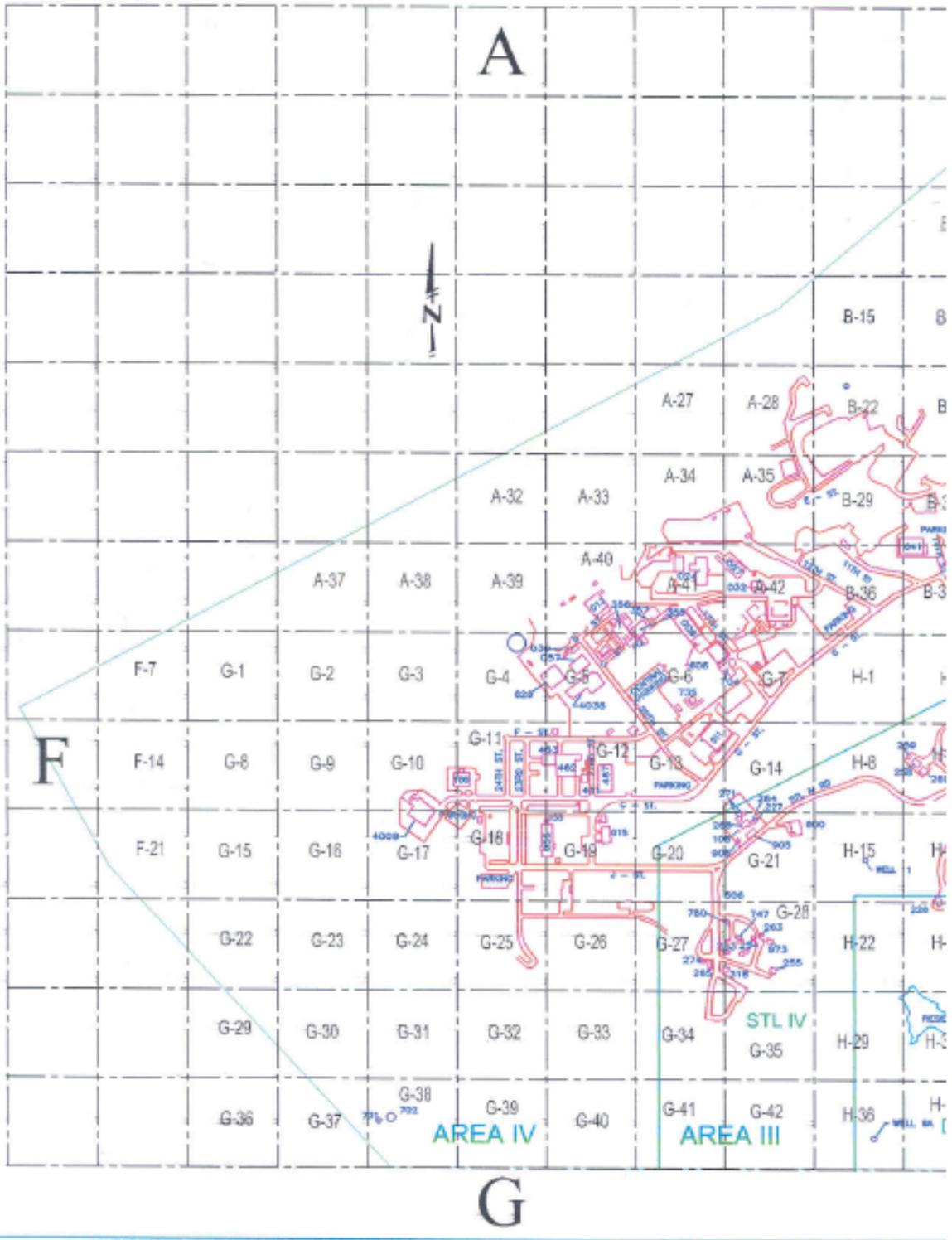

Figure 4.2
Sheet 1 of 3

ORY

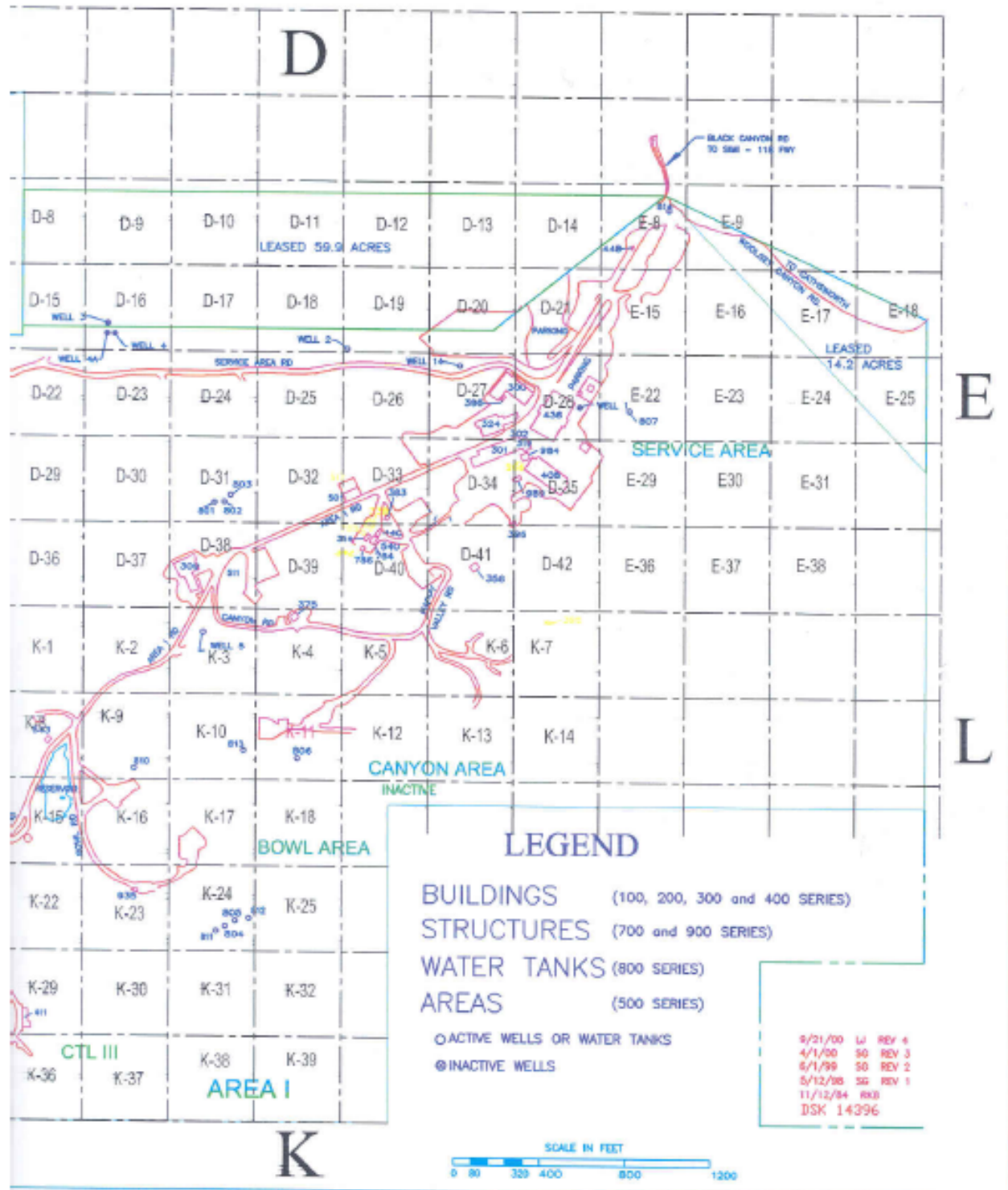
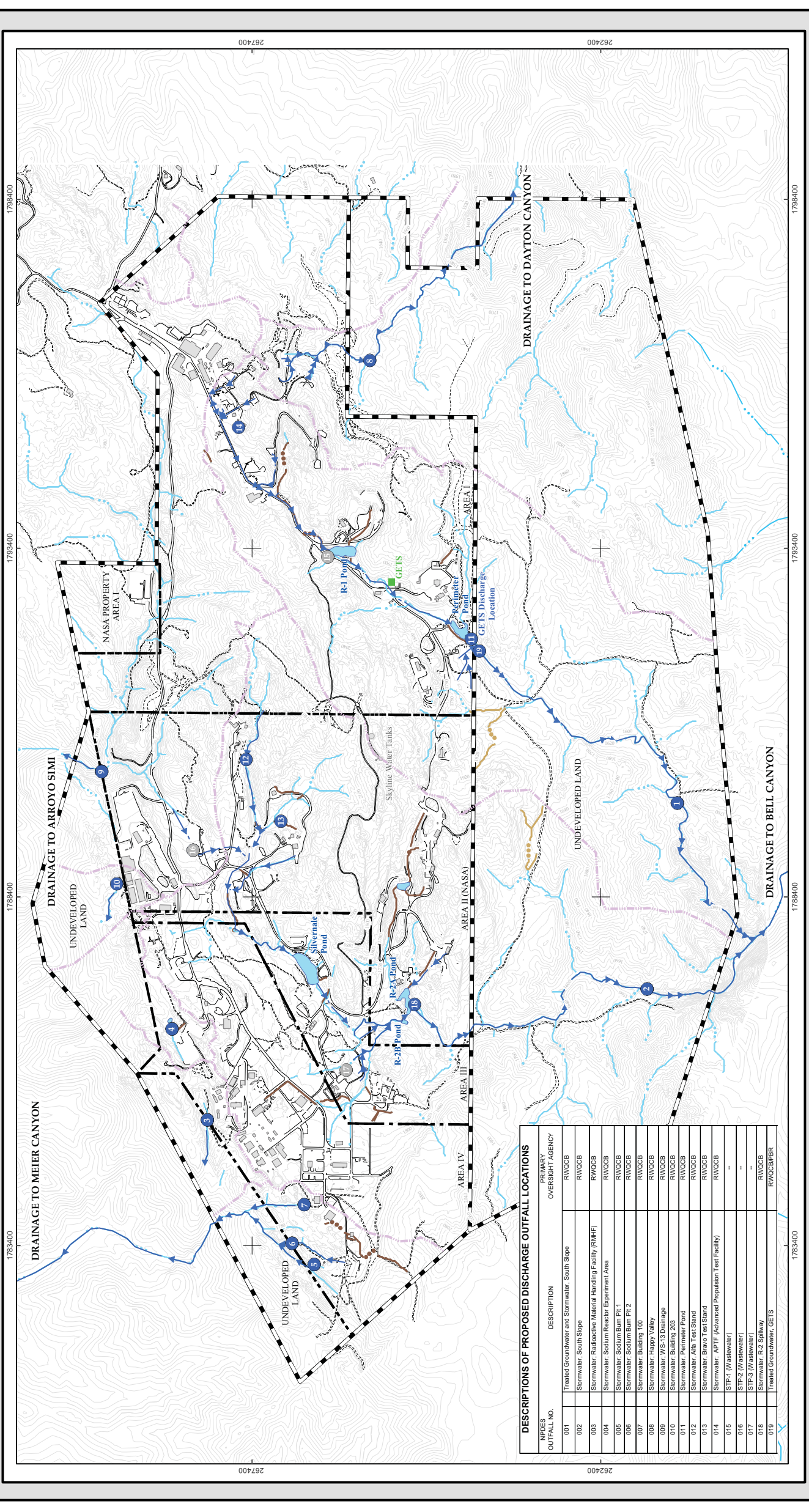
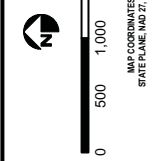

Figure 4.2
Sheet 3 of 3



DESCRIPTIONS OF PROPOSED DISCHARGE OUTFALL LOCATIONS

NPDES OUTFALL NO.	DESCRIPTION	PRIMARY OVERSIGHT AGENCY
001	Treated Groundwater and Stormwater, South Slope	RWQCB
002	Stormwater, South Slope	RWQCB
003	Stormwater, Radioactive Material Handling Facility (RMHF)	RWQCB
004	Stormwater, Sodium Resear. Experiment Area	RWQCB
005	Stormwater, Sodium Bum Pit 1	RWQCB
006	Stormwater, Sodium Bum Pit 2	RWQCB
007	Stormwater, Building 100	RWQCB
008	Stormwater, Happy Valley	RWQCB
009	Stormwater, WS-13 Drainage	RWQCB
010	Stormwater, Building 203	RWQCB
011	Stormwater, Perimeter Pond	RWQCB
012	Stormwater, A16 Test Stand	RWQCB
013	Stormwater, Bravo Test Stand	RWQCB
014	Stormwater, AP1F (Advanced Population Test Facility)	RWQCB
015	STP-1 (Wastewater)	-
016	STP-2 (Wastewater)	-
017	STP-3 (Wastewater)	-
018	Stormwater, R-2 Showway	RWQCB
019	Treated Groundwater, GETS	RWQCB/PRR



MAP COORDINATES IN STATE PLANE, NAD 87, ZONE V

- Legend**
- NPDES Outfalls (RWQCB Primary Oversight Authority)
 - Historical NPDES Outfalls
 - Groundwater Extraction Treatment System (GETS)
 - Effluent Pathways
 - Surface Water Drainage Divide
 - Natural Drainage
 - Concrete Lined Drainage
 - Graded Drainage
 - Surface Water Reclamation Ponds

- Base Map Legend**
- SSFL Property Boundary
 - Area Boundary
 - Ground Elevation Contours
 - Drainage Pathways
 - AC Cutting
 - Dirt Road
 - Existing Building or Structure

Site Map with Outfall Locations and Storm Water Drainage Systems

Figure 4.3

4.2 GENERAL DESCRIPTION OF HYDROLOGY

4.2.1 Surface Water

An extensive stormwater runoff drainage and capture system exists at SSFL (Figure 4.3). Stormwater runoff discharges from SSFL are subject to requirements stipulated in NPDES Permit #CA0001309. Approximately 60% of any discharge exits the property via two southerly discharge points (Outfalls 001 and 002) to Bell Creek, a tributary of the Los Angeles River. The remaining stormwater discharges to the northwest from Outfalls 003 through 007 and 009 and 010 toward the Arroyo Simi and to the southeast from Outfall 008 toward Dayton Canyon, which flows to Bell Creek.

There are five ponds situated at various locations within the SSFL site. These ponds were formerly part of a water reclamation system associated with previous propulsion testing. Currently, the ponds serve to provide storm water runoff retention and management capability, including controlled release to the outfalls as described above.

The SSFL NPDES permit requires monitoring of stormwater and Area 1 GET System discharges from SSFL. Monitoring reports summarizing discharged water quality data are submitted to the Regional Water Quality Control Board according to a schedule found in the NPDES permit.

4.2.2 Groundwater

Groundwater present in the alluvium and weathered bedrock beneath SSFL is defined as near-surface groundwater, while that which occurs in the unweathered bedrock is defined as Chatsworth formation groundwater. Groundwater monitoring at SSFL involves sample collection from a network of 223 shallow wells and piezometers, 168 deeper Chatsworth formation wells, and 29 springs and seeps. There are approximately 13 locations where near-surface groundwater is known to occur. Two of these are fairly laterally extensive, one of which is located near the SSFL Area I Road and the other at the Burro Flats area. The lateral extent of near-surface groundwater is relatively limited in the Happy Valley, RD-9, FSDF, and Coca drainages. Near surface groundwater in the remaining areas is very localized and range between 15 to 40 feet below ground surface across SSFL. In some areas near surface groundwater is as shallow as 4 feet below ground surface. Groundwater springs and/or seeps are found in the southern portions of the SSFL site, as well as off-site.

Near-surface groundwater is vertically continuous (i.e., not separated by the vadose zone) with deeper Chatsworth formation groundwater at several areas within SSFL. The largest of these areas occurs in the west-central portion of the site (Burro Flats) and in the southern portion of the Area I Road. Perched near-surface groundwater occurs at other locations within SSFL, most notably in the northeastern and northwestern portions of the site. The near-surface groundwater flow system at SSFL follows both the direction and slope of topographic changes, with the exception of the northern portion of Burro Flats in Area IV, where a groundwater divide exists along a northeast to southwest-trending line.

The principal water bearing system at SSFL is the fractured Chatsworth formation, composed of massive sandstone with interbeds of shale and siltstone. Chatsworth formation groundwater occurs regionally, rather than being localized in extent as with near-surface groundwater at the

site. Measured depths to groundwater in the Chatsworth formation vary greatly with location across SSFL, depending on geology and historical pumping practices at former water supply wells. Depths to water measured in Chatsworth formation wells (where groundwater is not vertically continuous with near-surface groundwater) generally range between 60 and 300 feet below ground surface and can vary greatly over short distances.

4.3 TOPOGRAPHY/GEOLOGY

4.3.1 Topography

SSFL occupies hilly terrain exhibiting approximately 1,100 feet of topographic relief near the crest of the Simi Hills. The highest surface elevations at SSFL occur along two general ridges that trend northeast to southwest near the center of the site, with a maximum elevation of 2,245 feet above mean sea level. The lowest elevation within SSFL occurs at the eastern property boundary in Dayton Canyon and has an elevation of approximately 1,175 feet above mean sea level. The lower elevations at SSFL occur primarily along the eastern, southern and north-central to northwestern perimeters of the property. A broad, relatively flat area of topography exists within the northwestern portion of SSFL and is referred to as the Burro Flats area.

4.3.2 Geology

SSFL is located in the Transverse Ranges of southern California, characterized by north-south compression where geologic structures such as faults and folds strike in an approximately east-west direction. Most of the site is underlain by the late Cretaceous Chatsworth formation, consisting of interbedded sandstone and shale. It is overlain by the Simi Conglomerate Member of the Paleocene Santa Susana formation to the north, faulted against the Santa Susana formation to the west, and overlain by southward-dipping late Tertiary formations to the south. Structurally, the facility is located on the south flank of an east-west striking and westward plunging syncline that passes through the central part of Simi Valley.

The primary geologic units present at SSFL are Quaternary Alluvium and the Cretaceous Chatsworth formation. The majority of the site is comprised of exposed bedrock of the Chatsworth formation. Alluvial soils are generally thin at SSFL, typically ranging from 5 to 15 feet thick. These soils usually occur in topographic lows and along stream drainages, although a thin, 5 to 10 feet thick alluvial veneer covers a broad expanse in Area IV (Burro Flats area). Disturbed soils also have been used as fill materials in developed portions of SSFL. Native and fill soils are generally comprised of the weathered Chatsworth formation materials and are typically fine-grained silty sands. The thickest deposits of alluvium or fill soils occur in the northeastern (up to 40 feet) and north-central (up to 30 feet) portions of the SSFL. Thin deposits of freshwater sediments occur on-site in the surface water ponds. These sediments are 2 to 5 feet thick and are comprised of clayey sand, clayey silt, and fine-grained sands, some with a high organic content.

A number of faults are present at the site and have two general orientations. The North, Coca, Burro Flats, Woolsey Canyon, IEL, and Happy Valley faults generally strike east-west, while the Shear Zone and Skyline faults generally strike northeast to southwest. All faults appear to dip nearly vertically. A number of the faults produce nearly linear features that form topographic lows, which result in drainages for surface water.

4.4 SPILL EVENTS

SSFL has not experienced a spill event which discharged into or upon a navigable water of the United States or adjoining shorelines. Within the past ten years, one spill event was reported to environmental agencies. This occurred during the Topanga fire of September 28 through 30, 2005, which resulted in release of untreated groundwater containing trace amounts of solvents when double-walled HDPE pipes melted from the heat. Additionally, there were releases of small amounts of oil, Freon, and asbestos reported at that time.

5.0 SPILL PREVENTION AND RESPONSE PLAN

5.1 PURPOSE

The purpose of the Spill Prevention and Response Plan (SPRP) is to establish standardized procedures for spill prevention and response. The SPRP incorporates the requirements of Title 40, Section 112 in the Code of Federal Regulations (CFR) for a Spill Prevention Control and Countermeasures (SPCC) Plan. It also includes the requirements of 40 CFR 264 and 265 for a hazardous waste contingency plan and Title 19, Section 2731 in the California Code of Regulations (CCR) for emergency response procedures for a release or threatened release of hazardous materials.

5.2 GOAL

The goal of the SPRP is to describe spill prevention and response actions appropriate to the activities and materials present at SSFL. This includes procedures to be followed in the event of releases, accidents, and spills involving hazardous substances and identification of personnel responsible for carrying out spill-related response functions.

5.3 OBJECTIVES

The SPRP:

1. Details spill prevention and response procedures consistent with regulatory requirements.
2. Provides a foundation for development of related planning documents as necessary.
3. Assures spills will be addressed in a manner that will reduce contamination.
4. Requires facility equipment to be maintained in an environmentally safe manner.

5.4 SCOPE

The requirements documented in this plan apply to all personnel working at the SSFL facility, including all contractors who receive, store, or use oil and/or hazardous materials.

5.5 REGULATORY OVERVIEW

Compliance is maintained at SSFL with the following regulations as they are applicable.

5.5.1 Federal

29 CFR 1910.120	Hazardous Waste Operations and Emergency Response
40 CFR 110	Discharge of Oil
40 CFR 112	Oil Pollution Prevention

40 CFR 125	Criteria and Standards for the National Pollutant Discharge Elimination System (NPDES)
40 CFR 264	Standards for Owners and Operators of Hazardous Waste Treatment, Storage and Disposal Facilities [Requirements applied only as applicable]
40 CFR 265	Interim Status Standards for Owners and Operators of Hazardous Waste Treatment, Storage, and Disposal Facilities [Requirements applied only as applicable]
40 CFR 270	EPA Administered Permit Programs: The Hazardous Waste Permit Program
40 CFR 300	National Oil and Hazardous Substances Pollution Contingency Plan
40 CFR 355	Emergency Planning and Notification
40 CFR 370	Hazardous Chemical Reporting: Community Right-to-Know

5.5.2 State

California Health and Safety Code (HSC) Chapter 6.95	Hazardous Materials Release Response Plans and Inventory
Title 8, section 5192	Hazardous Waste Operations and Emergency Response
19 CCR 2731	Emergency Response Plans and Procedures
22 CCR 66264.50 - 56	Contingency Plan and Emergency Procedures
22 CCR 66265.50 - 56	Contingency Plan and Emergency Procedures (Interim Status Standards)

5.5.3 Local

Ventura County Environmental Health Division (EHD) Business Plan requirements.

5.6 POLICIES

5.6.1 Oil

All oil shall be handled, used, and stored in a manner that avoids or minimizes the possibility of an accidental spill or discharge to water, land, or air at SSFL.

5.6.2 Hazardous Substances

All hazardous materials and hazardous waste shall be handled, used, and stored in a manner that avoids or minimizes the possibility of an accidental spill or discharge to water, land, or air.

Any remedial actions beyond immediate emergency response measures to correct or neutralize reportable spills will be coordinated with the EPA, state, and local agencies.

5.6.3 Pollution Control

Pollution and contamination control activities shall be carried out in conformance with Boeing Company-wide procedures, approved SSFL Procedures, applicable regulatory requirements, and direction received from regulatory agencies, as well as acquisition, storage, use, transportation, and disposal of hazardous substances. All contracts for disposal of oil products and/or hazardous substances shall contain provisions requiring the disposal to be in accordance with federal, state, and local rules and regulations.

5.6.4 Plan Responsibility (Updates/Implementation)

Responsibility for implementing the SPRP shall rest with the Incident Commander (IC). Maintenance and periodic updating of the SPRP shall be conducted in accordance with federal, state, and local rules and regulations by the SSFL Environment, Health & Safety (EHS) department in consultation with the IC and Security & Fire Protection.

The SPRP shall be reviewed and evaluated at least once every three years. However, the Hazardous Materials Release Response, Business Plan, and Inventory (Business Plan), of which the SPRP is a part, must be reviewed every year. If the review shows that more effective prevention and control techniques will significantly reduce the likelihood of a spill event, and if the techniques are field proven and can be procured at the time of the review, the SPRP shall be amended to reflect the new techniques.

The SPRP shall be reviewed and amended as necessary whenever:

- (1) A single spill event discharges more than 1,000 gallons of oil;
- (2) A release of hazardous materials occurs onto the land or waters at this facility in excess of the reportable quantity as specified in 40 CFR 117; or
- (3) There are two spill events, discharging oil in harmful quantities, as defined in 40 CFR 110, within a 12-month period.

Additionally, the plan shall be amended if there is a change in facility design, construction, operation, or maintenance which materially affects the facility's potential for the discharge of oil or hazardous substances.

The SPRP shall also be updated when the IC changes or when the inventory of emergency equipment changes significantly.

The SPRP shall be amended in accordance with all federal, state, and local rules and regulations.

A professional engineer shall certify that any significant changes to the SPRP adhere to good engineering practice and that the plan complies with all regulatory requirements.

Changes in the plan require the appropriate management approval. Changes must be implemented within 6 months from the date of the plan revision.

6.0 SPILL PREVENTION CONTROL AND COUNTERMEASURES

6.1 INTRODUCTION

This part of the SPRP serves to identify specific procedures for handling and storing oils, hazardous substances, and other materials of concern to prevent uncontrolled discharge into or upon the waters of California or the United States.

6.2 OIL AND HAZARDOUS SUBSTANCES

6.2.1 Inventory

The SSFL Hazardous Materials Inventory - Chemical Descriptions are included in the “SSFL Hazardous Materials Release Response, Business Plan, and Inventory”, of which this document is a part. In total, these comprise the entire hazardous materials inventory at SSFL as defined by 40 CFR 370, 19 CCR 2729 and Ventura County EHD requirements.

6.2.2 Material Safety Data Sheets

Acquisition and availability of Material Safety Data Sheets (MSDS) for all materials used and/or stored at SSFL are supervised by the Boeing Environment, Health and Safety department (EHS). MSDSs are available from the SSFL EHS web site, Project Impact Evaluation packages, and Service Provider Health and Safety Plans.

6.3 OIL AND HAZARDOUS MATERIALS HANDLING AREAS

Grid coordinates for locations where oil and hazardous materials may be handled are referenced in the applicable Hazardous Materials Inventory - Chemical Descriptions and are shown in the facility maps included in the “SSFL Hazardous Materials Release Response, Business Plan, and Inventory”.

6.4 IDENTIFICATION OF POTENTIAL SPILL SITES

A potential spill site is any building, structure, installation, equipment, pipe or pipeline, well, pit, pond, lagoon, impoundment, ditch, landfill, or storage container which could cause or be affected by a release. Areas have been designated as potential oil and hazardous substance spill sites if there is the potential for release of material to the environment in amounts that may endanger human health or the environment. At SSFL, potential spill sites include areas where oil and hazardous substances are stored and used, as well as those areas where hazardous wastes are managed. These areas are identified in the Hazardous Materials Inventory - Chemical Descriptions.

6.5 SPILL RESPONSE EQUIPMENT

With the discontinuation of research and testing operations at SSFL, accompanied by progress in dismantling the physical facility, provision of emergency response services has shifted from Boeing personnel to contracted providers of required services. The magnitude and hazard-level of potential spills have decreased significantly. Boeing emergency response personnel act in a supervisory and coordination role. Equipment and supplies are maintained on-site by Boeing at a level required to address minor releases and to provide First Responder attention to larger and/or

more hazardous incidents. A list of this equipment is presented in Appendix A, and a list of fire extinguisher locations is maintained by Security & Fire Protection. Emergency response and mitigation addressing more serious situations will be carried out by the contracted hazardous waste services provider and by public emergency response agencies.

SSFL EHS, in conjunction with Security & Fire Protection, is responsible for providing supervision and coordination of emergency services. They will make all arrangements requiring outside services in the event of a spill or release of hazardous materials. EHS shall:

1. Maintain an open purchase order with a pumping service capable of pumping out diked areas, temporary holding tanks and other emergency accumulation provisions, and secondary containment basins.
2. Maintain a supply of sorbent materials in readiness for initial mitigation of spills.
3. Maintain an outside source which can furnish sandbags and sorbent material in large quantities on an emergency basis.
4. Make arrangements for disposition and/or disposal of any hazardous materials and wastes generated as the result of a spill event.

6.6 OIL AND HAZARDOUS SUBSTANCES - SPILL PREVENTION

Areas where a significant spill potential exists comply with the requirements of 40 CFR 112, "Oil Pollution Prevention and Response; Non-Transportation-Related Onshore and Offshore Facilities", as outlined below.

6.6.1 General Procedures

Oil and hazardous substances storage locations are protected as follows:

1. Tanks and containers used for storage of oil or hazardous substances are compatible in material and design with the substance being stored and the storage conditions.
2. Secondary containment is provided for oil and hazardous substance storage locations when there is potential for discharge to defined drainage channels. Secondary containment may be in the form of double walls with interstitial leak detection, steel or concrete basins, curbed areas, or specific purpose containment units. The capacity of secondary containment is equivalent to 100 percent of the volume of material in the largest tank or container that is being serviced by the containment. Where applicable, secondary containment will include the addition of adequate freeboard to accommodate fire suppression agent and rainwater from a 24 hour, 25-year storm.
3. Whenever there is a significant potential for an unplanned release of oil or hazardous substances, preventive measures will be in place to prevent discharge to the environment. Stormwater drainages are protected from a potential spill through the use of ponds, natural and constructed diversions, depressed areas, and natural and/or constructed barriers.

4. Drainage from secondary containment is controlled by valves, standpipes, manually operated pumps, or other active means. All valves in active secondary containment areas are kept closed, with an operator present when opened. Following a rainfall event, accumulated water retained in secondary containments is inspected and, when necessary, sampled to determine proper disposal. Secondary containments will be pumped out into containers when there is sheen on the water or sampling results indicate the presence of oil and/or hazardous substance(s) at regulated concentrations. The water will be managed in compliance with regulatory requirements. Stormwater within NPDES permit limits may be discharged to the ground.
4. Pressure vessels at SSFL will be ASME coded as appropriate to minimize spill potential.
5. Oil and hazardous substances tank storage installations will comply with National Fire Protection Standards, the California Fire Code, and Title 19 of the California Code of Regulations (State Fire Marshall requirements).

6.6.2 Oil, Fuel, and Hazardous Materials Storage

No hazardous waste tanks remain on-site, and, with the exception of the Praxair liquid nitrogen storage and distribution system, pressure vessels and non-fuel tanks formerly containing hazardous substances have been evacuated. Bulk containers and portable tanks individually containing greater than 55 gallons of hazardous materials are located as described in the Hazardous Materials Inventory - Chemical Descriptions.

The on-site storage of fuels has been sharply reduced.

1. Primary gasoline service for SSFL is now provided by a 500 gallon aboveground tank with dispenser located in the Building 1324 parking lot in Area I. This tank is of the "ConVault" type, UL 2085 rated with protected primary and secondary containment.
2. Other on-site fuel storage includes the 1,000 gallon diesel tank at the Skyline repeater station and much smaller portable tanks found on remaining generators and pumps at the SSFL. Secondary containment for the repeater station diesel tank is provided by a concrete basin.

There has been a substantial decline in the inventory of Oil-Filled Operational Equipment containing greater than 55 gallons of oil at SSFL. This equipment is almost exclusively represented by transformers located throughout the SSFL site. At the present time transformers containing greater than 55 gallons of oil are installed at the following locations (Grid locations correspond to the master map in Section 4.0 above):

A-40	D-27	G-6	H-2	J-28
B-13	D-33	G-7	H-9	J-29
B-18	D-34	G-11	H-17	J-33
B-20	D-38	G-12	H-34	J-35

B-35	E-8	G-13	H-35	C-38
G-5	G-17	H-39		

6.6.3 Drums and Small Containers

1. Secondary containment is used, as practical, for all drum/small container storage of oil and hazardous substances. With the advancing demolition of SSFL, drum spill containment pallets are a primary form of secondary containment now employed at the site. All drum and small container containments will accommodate the contents of the largest container.
2. Oil and hazardous substances are stored in containers compatible with the material stored and the storage conditions.
3. Operating personnel conduct routine visual inspections of containers holding oil or hazardous substances.

6.6.4 Transfer of Oil and Hazardous Substances within SSFL

Most of the former oil and hazardous substance transfer infrastructure at SSFL is no longer in active service. The primary active, hazardous pipeline remaining at SSFL is a high pressure nitrogen supply running parallel to Area I Road, CTL-III Road, and CTL-5 Road. No oil or fuel transfer pipelines remain in service. Hydrogen storage and distribution have been discontinued and purging of associated tanks and pipelines is in advanced stages.

6.6.5 Truck Loading/Unloading of Oil and Hazardous Substances

The only bulk shipments of oil and hazardous substances that continue at this time are deliveries of fuel to refill the 500 gallon gasoline tank and the bulk nitrogen shipments to replenish the 6,000 gallon liquid nitrogen unit at the Praxair facility. The Alfa-Bravo Fuel Farm is no longer used, and bulk shipments of all compressed gases are no longer taking place.

Truck loading and unloading of oil and containerized shipments of various hazardous substances (primarily chemicals used in groundwater and stormwater treatment systems) are handled in accordance with the minimum standards of the US Department of Transportation (DOT) and the US Environmental Protection Agency (EPA). Regulatory references governing transportation requirements for oil and hazardous substances are:

1. Hazardous Materials Transportation Act (HMTA) and the Hazardous Materials Transportation Uniform Safety Act Amendments of 1990, 49 USC 1801 et seq.
2. 49 CFR 100 to 185, Transportation
3. 40 CFR 112, Oil Pollution Prevention
4. 40 CFR 263, Hazardous Waste Transporters

6.6.6 Degreasers

SSFL no longer uses solvent degreasing bath equipment. When degreasing is required, aqueous cleaning solutions are generally used, although wipe operations using limited quantities of non-chlorinated solvents may occur, especially during facility maintenance.

6.7 OIL AND HAZARDOUS SUBSTANCES STORAGE INSPECTIONS

All field personnel, including contractors, are expected to report leaks and spills of oil and hazardous substances. This expectation is communicated through the Boeing Service Provider Manual and during Service Provider Safety Tailgate Meetings.

6.7.1 Aboveground Storage Tank Inspection

On-site Contract Coordinators and SSFL management are responsible for assuring that all oil and hazardous substance tanks, piping, pumps, and valves and containers in their areas are under continuing surveillance in accordance with regulatory requirements.

Surveillance includes the following:

1. Inspecting tanks for leaks.
2. Checking associated piping, valves, pumps, tank supports and foundations for leakage and/or deterioration.
3. Checking surrounding soil and secondary containment areas for any oil/hazardous material accumulation and other signs of spills and leaks.
4. Checking that valves draining secondary containments are in a closed position.

6.7.2 Underground Storage Tank (UST) Inspection

There are no active USTs at SSFL.

6.8 SPILL PREVENTION RESPONSIBILITIES

Specific responsibilities to prevent the occurrence of a spill event are described below.

6.8.1 Boeing Employees

Personnel who are assigned equipment to be used in environmental management and monitoring are responsible for assuring that it is maintained in good operating order and in accordance with applicable permit conditions. They also maintain necessary usage logs and other required records.

All Boeing employees working in areas where there may be contact with hazardous substances are trained in the basic use, handling, and storage of these substances in accordance with the EHS Hazard Communication Program.

6.8.2 Functional Management

Non-EHS management present at SSFL is responsible for notifying EHS of any prospective work requiring EHS support, especially when there will be an increased likelihood of a significant spill event.

6.8.3 Incident Commander or Delegate (Security & Fire Protection)

The Incident Commander (IC) or his delegate has the following spill prevention responsibilities:

1. Coordinate oil and hazardous substance spill control activities for SSFL.
2. Periodically monitor plan compliance.
3. Provide surveillance over response readiness capability.
4. Participate in updating the SPRP.
5. Coordinate with SSFL management when there are changes in operating conditions that significantly increase the possibility that an unplanned release may occur.
6. Provide up-to-date information pertaining to SPRP implementation as requested by SSFL management.

6.8.4 Environment, Health and Safety (EHS)

EHS has the responsibility of maintaining an emergency response capability for oil and hazardous material spills. EHS is also responsible for notifying the appropriate environmental regulatory agencies should a reportable release occur. Appendix B contains the procedure for notifying environmental regulatory agencies.

EHS staff is responsible for the following:

1. Reviewing changes in federal, state, and local laws and regulations which affect the SPRP and revising the SPRP accordingly.
2. Reviewing and recommending new spill control technology.
3. Identifying areas where an unplanned release may potentially occur. Additionally, EHS shall recommend spill safeguard provisions. The IC shall be notified of any required changes to the SPRP.
4. Assuring that the SPRP is updated as required and that suggested revisions to the SPRP are reviewed by applicable SSFL staff to maintain compliance with all applicable rules, regulations, and appropriate best management practices.
5. Maintaining spill response procedures and capabilities.

As required in the Hazard Communication Program, EHS has the responsibility to transmit hazardous materials information to Boeing employees. This includes training Boeing employees,

as outlined in the Hazard Communication Program. EHS also maintains the MSDS system for materials in use or stored at SSFL.

6.8.5 Site Services

Site Services shall maintain SSFL equipment and infrastructure in good condition, as required to minimize the potential for a spill event.

6.8.6 Contractors

As stated in the Boeing Service Provider Manual, contractors working at SSFL are required to notify EHS, in writing and through the On-site Contract Coordinator, of hazardous substances and oil (including fuel) brought on-site.

Contractors are also responsible for managing hazardous substances and oil brought on-site as directed by EHS and in Boeing approved locations.

6.9 DOCUMENTATION

6.9.1 SPRP

An up-to-date copy of the SPRP, included in the “SSFL Hazardous Materials Release Response, Business Plan, and Inventory”, is maintained at the following locations:

1. Post 505 (SSFL front gate control point)
2. EHS
3. Emergency Operations Center document cabinet in Bldg. 1436.

A copy of the “SSFL Hazardous Materials Release Response, Business Plan, and Inventory” is also submitted to the Ventura County Environmental Health Division. Additionally, the plan will be made available, upon request, to the Regional EPA Administrator, other properly authorized members of the Regional EPA staff, and other environmental agencies.

6.9.2 Inspection Reports

The completed tank, container, etc. periodic visual inspection forms are maintained by the responsible On-site Contract Coordinator or SSFL management overseeing or performing the inspections.

6.9.3 Spill Documentation

If a reportable spill occurs, EHS shall retain the documentation for the required period, as specified by federal, state, and local regulations.

6.10 PERIODIC DRILLS

Emergency response drills are conducted periodically by SSFL emergency response personnel. Emergency response procedures are revised as necessary by EHS.

6.11 SECURITY

The entire SSFL facility is secured by fencing, locked gates, and/or terrain that is not accessible to vehicles. Additionally, Security & Fire Protection monitor the site twenty-four hours daily and provide controlled access through the security checkpoint at the main gate (Post 505 front gate control point).

Storage or operating facilities where a spill could originate are under surveillance by Security & Fire Protection. The IC is alerted by Security & Fire Protection regarding any abnormal or dangerous conditions which might result in a spill event. The IC reports this information to EHS.

Storage facilities or equipment areas where an oil spill could occur are provided with sufficient lighting required for spill detection and corrective maintenance.

The three Hazardous Waste Staging Areas are surrounded by chain link fencing with locking gates, which are closed when the assigned personnel are not in attendance.

6.12 EMPLOYEE TRAINING PLAN

Management is responsible for ensuring that Boeing personnel under their supervision receive proper training related to spill control and countermeasures as appropriate for their operating areas. EHS ensures that appropriate personnel are instructed in the implementation of the SPRP as required. As a provision of their contracts, all contractors working on-site are required to train their personnel in compliance with all applicable regulatory requirements. Requirements that are specific to Boeing and SSFL are communicated to contractors in the Boeing Service Provider Manual. Contractor safety tailgate meetings are employed as a means of re-emphasizing Boeing and SSFL requirements, including those pertaining to spill prevention and countermeasures.

Boeing employee training in the handling of hazardous materials is an EHS responsibility. This training consists of hands-on, person-to-person, and computer-based training, as required by the specific employee duties. It includes provisions required by 40 CFR 112, 264, and 265; the State of California Health and Safety Code, Section 25504(c); 19 CCR 2732; and 22 CCR 66264.16 and 66265.16. The following topics are addressed:

1. Familiarity with plans and procedures specified in the SPCC and Contingency Plans.
2. Methods for safe handling of hazardous materials.
3. Safety procedures applicable to releases or threatened releases of oil or hazardous material.
4. Use of emergency response equipment and supplies
5. Procedures for coordination with local emergency response organizations
6. Internal alarm and notification procedures.
7. Evacuation and re-entry procedures and assembly point locations.

8. Hazard Communication training, including specific hazard(s) of each chemical to which employees may be exposed, considering routes of exposure (i.e. inhalation, ingestion, absorption).
9. Recognition and operation of equipment and mechanical controls (e.g., valves) that are frequently encountered during hazardous materials handling.

This training takes into consideration the position of each employee, and is provided:

1. Initially for all new employees with job responsibilities involving hazardous materials.
2. Annually, where required for employees with job responsibilities involving oil or hazardous materials, and may be in the form of refresher courses.

Employees will not handle oil or hazardous materials without supervision until trained.

6.12.1 Training Documentation

The following documents and records are available at SSFL for Boeing employees with positions related to hazardous waste management:

1. Job title
2. A description of the position, including required skills, education or other qualifications, and duties
3. A description of the type and amount of both introductory and continuing training provided.
4. Records documenting that requirements for training or job experience have been satisfied.

Current employee training records will be retained until closure of the facility. Training records of former employees will be retained for at least three years following termination of employment.

7.0 CONTINGENCY PLAN

The Contingency Plan portion of the SPRP incorporates the applicable requirements of the Facility Spill Contingency Plan (FSCP) for Oil and Hazardous Materials required by 40 CFR 264 and 40 CFR 265; the Oil and Hazardous Substance Pollution Contingency (OHSPC) Plan required by 40 CFR 300; and the requirements of 19 CCR 2731.

The following outlined procedures will be followed in the event of:

- An actual or potential oil spill
- An actual or potential hazardous substances spill
- Fire, explosion, or other emergency conditions resulting from oil or hazardous substance spills.

The Disaster Preparedness Plan (DPP) serves as the master plan to implement the general policies and organizational responsibilities for the protection of personnel, facilities, equipment, products, and records of Boeing and the Government in the event of an impending or actual emergency, regardless of cause. The SPRP serves as a supplement to the DPP for spills or emergencies resulting from spills. A copy of the DPP is maintained in the Bldg. 1436 Emergency Operations Center document cabinet.

7.1 INTRODUCTION

The SPRP Contingency Plan identifies procedures that will be implemented in the event of a release, accident, or spill involving oil or hazardous substances.

The SPRP Contingency Plan provides for coordinated and integrated response by SSFL personnel to prevent and minimize hazards and damage from spills of oil and hazardous substances at the facility.

7.2 SCOPE

This SPRP Contingency Plan applies to the entire SSFL facility and is activated for any oil or hazardous substance spill or emergency (fire, explosion, etc.) resulting from an oil or hazardous substance spill.

7.2.1 Radioactive Materials Handling Facility (RMHF)

As a result of the specialized nature of materials routinely handled and/or present in the area, a supplementary contingency plan has been developed addressing the specific conditions at the Radioactive Materials Handling Facility (RMHF). Copies of the RMHF Contingency Plan are in the possession of the IC and in the office at RMHF. If an emergency occurs at RMHF, the IC will refer to the RMHF Contingency Plan as appropriate, in addition to the DPP and SPRP.

7.3 SPILL DISCOVERY

7.3.1 Initial Discovery

The first person becoming aware of an oil or hazardous substance spill or emergency (fire, explosion, etc.) resulting from an oil or hazardous substance spill shall IMMEDIATELY notify the Security & Fire Protection Control Center by 2-way radio or by cell phone at (818) 466-8911. Refer to Table 7-1, Emergency Response Checklist, for subsequent response steps. Discovery of a spill can either be made inadvertently or as the result of a routine inspection.

Table 7-1 Emergency Response Checklist

EMERGENCY RESPONSE CHECKLIST	
Spill Event	
	<ol style="list-style-type: none">1. NOTIFY SECURITY & FIRE PROTECTION IMMEDIATELY: 2-way radio or cell phone at (818) 466-8911.2. If qualified, and it is possible and safe to do so, stop the flow.3. Contain spill using any appropriate material available, such as sandbags, gravel, boards, etc.4. If safe to do so, try to prevent the spill from entering surface waters.
Fires/Explosions	
	<ol style="list-style-type: none">1. NOTIFY SECURITY & FIRE PROTECTION IMMEDIATELY: 2-way radio or cell phone at (818) 466-8911.2. If possible, qualified and safe to do so, contain or extinguish fire.3. Locate nearest fire alarm and activate it.
Personnel Evacuation	
	When evacuation of personnel is required, cease work in the area and clear the area of all personnel not responding to the emergency (move up-wind). Evacuation (emergency assembly) areas are detailed in Figure 7-1.
Also refer to the following documents:	
	<ol style="list-style-type: none">1. Disaster Preparedness Plan2. Notification Procedure for Environmental Regulatory Agencies, Appendix B3. RMHF Contingency Plan
	THE INCIDENT COMMANDER/SECURITY & FIRE PROTECTION/SPILL CONTROL TEAM WILL DECIDE THE BEST WAY TO HANDLE AND CLEAN UP ANY HAZARDOUS MATERIALS INVOLVED IN THE EMERGENCY!!!

EMERGENCY INSTRUCTIONS

EMERGENCY NUMBER **911** FROM CELL PHONE
 818-466-8911

SANTA SUSANA FIELD LABORATORY - Bldg 31

Reporting Emergencies

Report any type of emergency, injury, illness, fire explosion or chemical spill to the Boeing Control Center by using the facility emergency number. Be sure to give your name, location, and nature of the emergency and telephone number. Use the building number and column number to describe the emergency locations. Stand by, if possible, to direct responding personnel.

Emergency telephone numbers are located on each telephone.

Shelter in Place

In an emergency you may be instructed by Security to go to your closest shelter in place location. Once in your shelter in place location, you must stay there until Security notifies you that the area is safe to exit.

Personnel Emergency Information

The Public address system is the preferred means of informing personnel of any action they must take during an emergency. If an emergency should occur and no public address system is accessible:

- Security and Fire Services officers using bullhorns will direct personnel.
- or
- Managers will direct personnel.

To protect yourself in the event of an emergency, familiarized yourself with the location of building exits and plan your emergency exit routes.

Exit Routes and Assembly Areas

For location of major exit routes and emergency assembly areas:

EMERGENCY ASSEMBLY AREAS

- ① North of Bldg 31-436
- ② North of Bldg 31-413
- ③ South West of Bldg 4
- ④ West of Bldg 44-034
- ⑤ North East of Bldg 44

LEGEND

 SHELTER IN PLACE

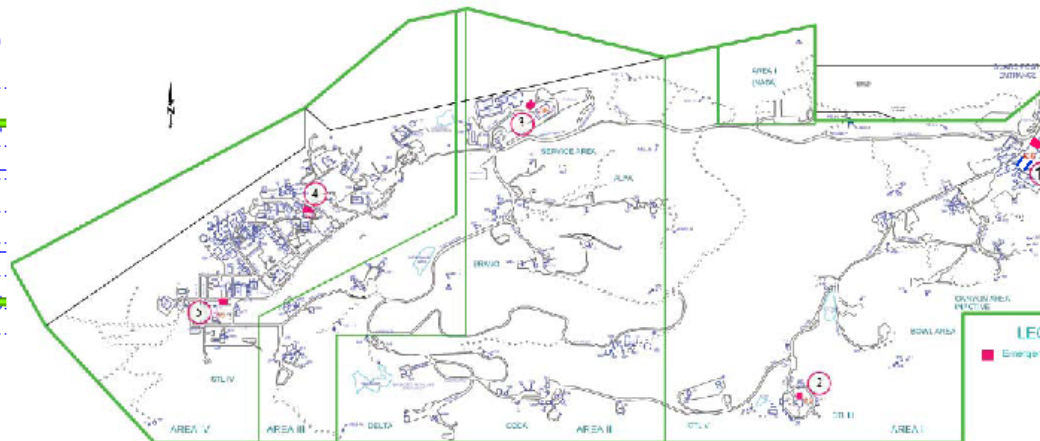
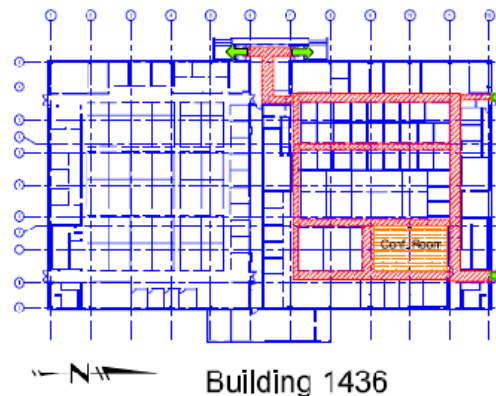

Figure 7-1 Emergency Assembly Areas

7.3.2 Initial Notification

The individual should provide Security & Fire Protection with as much of the following information as possible:

1. Name.
2. Phone number.
3. Spill location (facility building number, column location, etc.)
4. Material involved.
5. Estimate of amount and concentration of material spilled.
6. Any other relevant information.

7.4 INITIAL RESPONSE

Security & Fire Protection shall respond to the spill in accordance with the procedures outlined in the DPP, available at the Bldg. 1436 Emergency Control Center document cabinet.

According to the DPP, Security & Fire Protection shall:

1. Dispatch Security & Fire Protection Personnel to spill location.
2. Make initial notifications as required (refer to DPP, Section III, “Industrial Security Notifications”).

Based on information received from the responding Security & Fire Protection personnel, Security & Fire Protection shall do the following as applicable, depending upon actual conditions:

1. Barricade spill area to prevent exposure to personnel, equipment, and vehicles.
2. Evacuate immediate area.
3. Assign Security & Fire Protection Officers to control and protect area.
4. Stop operations and processes at the affected area.
5. Make further notifications as outlined in the DPP.

7.5 EVALUATION AND INITIATION OF RESPONSE ACTION

7.5.1 Spill Control Team

Upon arrival at the spill location, the following individuals will constitute the Spill Control Team and shall assume responsibility for on-scene coordination in the following order.

1. IC or delegate.
2. EHS Staff

3. Responsible Boeing Management
4. On-site Contract Coordinators

The IC or alternate shall:

1. Evaluate the magnitude and severity of the spill.
2. Determine type of removal/response necessary.
3. Coordinate with team members to stop leak and contain spill.

7.5.2 Non-Boeing Aid

If the IC determines that the spill is beyond the capability of the Spill Control Team, the IC shall increase the response level and coordinate notification of outside agencies needed for spill response assistance. The Spill Control Team shall stand by to assist outside agencies as necessary.

Requests for outside non-Boeing assistance will be made as determined necessary by the IC in consultation with the Spill Control Team.

Table 7-2, "Emergency Response Contacts," lists various local emergency response agencies and their phone numbers to be used by the Spill Control Team or Security & Fire Protection. A list of outside medical services used by the Spill Control Team is maintained by the Security & Fire Protection department.

If no outside assistance is required, in-house personnel and equipment shall be used to contain and clean-up the spill.

Table 7-2 Emergency Response Contacts

EMERGENCY RESPONSE CONTACTS (to be used by Spill Control Team and Security & Fire Protection only)		
Agency	Name	Phone No.
Hospital	West Hills Hospital and Medical Center 7300 Medical Center Dr. Canoga Park, CA 91303	(818) 676-4000
	Northridge Hospital 18300 Roscoe Blvd. Northridge, CA 91328	(818) 885-5396
Ambulance	Ventura County Fire Department	911 or (805) 389-9710
Fire Department	Ventura County Fire Department	911 or (805) 389-9710
Local Police	Ventura County Sheriff's Office	911 or (805) 654-2551
State of California Emergency Response	California Emergency Management Agency	(916) 845-8911 (916) 845-8510
	Cal/EPA - DTSC (Chatsworth Office)	(818) 717-6500
Emergency Authorities	National Response Center	(800) 424-8802
	EPA Region IX Spill, Haz Waste	(800) 300-2193 or (415) 947-4400

7.5.3 Material Identification

When there is a release of any hazardous substance, Security & Fire Protection, EHS, and area personnel shall identify, through observation, records, and/or chemical analysis, the following:

1. The substance's character: chemical identification, toxicity, corrosivity, reactivity, and ignitability.
2. Exact source.
3. Amount and extent of the released material.
4. Air contamination considerations.
5. Extent of soil and groundwater contamination.

7.5.4 Assessment of Health Effects

The EHS staff shall assess the possible health effects. They will also monitor the environment for contaminants and hazardous situations and shall recommend proper personal protective equipment.

7.5.5 Off-site Health Threat

If the emergency presents a threat to the health of individuals off-site, Communications, Security & Fire Protection, and EHS shall notify local authorities of the need to evacuate in accordance with Boeing corporate policy.

7.5.6 Evacuations

If it is necessary to evacuate SSFL personnel in response to an emergency, established evacuation routes shall be followed (see also Figure 7-1).

Evacuation procedures are provided in the DPP. Emergency assembly areas to be used during evacuation are identified in Figure 7-1.

7.5.7 Shelter in Place

If a release of toxic material occurs in an adjacent facility, and an evacuation of an immediate work area is not necessary or is potentially hazardous, the following safety precautions should be taken:

1. Personnel are to remain indoors.
2. All doors and windows are to be closed.
3. Ventilation systems will be turned off.
4. Personnel will wait for further instructions and announcements from Security & Fire Protection.

7.5.8 Notifications

EHS staff shall notify all environmental agencies as required, depending on the material and quantity spilled. The environmental notification procedures are available in Appendix B, "Environmental Notifications."

7.6 CONTAINMENT AND COUNTERMEASURES

Once the materials involved in a release have been identified and initial determinations regarding evacuations, etc. made, the Spill Control Team will focus on determining the best course of action to address the spill and cleaning up spilled material.

Depending on the nature and extent of the spill, the Spill Control Team may:

1. Determine the spill is within the capability of on-site Boeing personnel, or on-site contractors under the supervision of Boeing personnel, to mitigate and clean-up.
2. Determine that temporary containment of the spill is within the capability of on-site Boeing personnel, or on-site contractors under the supervision of Boeing personnel, but that the contracted spill management personnel must carry out actual mitigation and clean-up.

3. Determine that on-site Boeing personnel, or on-site contractors under the supervision of Boeing personnel, are incapable of addressing the spill and all action must be carried out by the contracted spill management personnel and/or public emergency response agencies.

Any remedial actions beyond immediate emergency response measures to correct or neutralize reportable spills will be coordinated with the EPA, state, and local agencies.

7.7 CLEANUP, DISPOSAL, AND RESTORATION

7.7.1 Cleanup

Cleanup of a spill by on-site Boeing personnel, or on-site contractors under the supervision of Boeing personnel, may involve the following:

1. Use of sorbents and skimmers.
2. Removal and containerization of spilled material and any impacted media affected by the spill.

7.7.2 Disposal

Disposal of spilled material and contaminated equipment shall be handled by EHS.

Disposal of all materials will be carried out in accordance with federal, state, and local regulations and applicable directives from regulatory agencies.

7.7.3 Restoration

Boeing will endeavor to return the environment to the condition it was in before the spill.

7.8 FOLLOW-UP

7.8.1 Release of Area

EHS must release areas affected by a spill event before re-occupation by personnel takes place.

Additionally, EHS shall notify environmental agencies as required before resuming operations.

7.8.2 Written/Follow-up Notifications

Follow-up notifications shall be made in accordance with regulatory requirements and as outlined in Appendix B, Environmental Notifications.

7.8.3 Spill Control Team Review/Written Report

The IC shall convene a meeting of the Spill Control Team, if deemed necessary, to review the spill response and prepare a written record. The report is to include recommendations to prevent any recurrence.

7.9 EARTHQUAKES

SSFL is underlain by bedrock and prior earthquakes experienced in the area have not caused significant damage. No specific areas or systems have been identified that may be prone to earthquake damage.

Where appropriate, SSFL facilities have been provided with emergency power and lighting. Buildings should be evacuated as described above in section 7.5.6, "Evacuations." After a serious earthquake has subsided, Security & Fire Protection, EHS, and Site Services will examine buildings and grounds for structural weaknesses; equipment hazards including fallen, live, and exposed electrical wiring; escaping gas or dangerous chemicals; and damaged containers or tanks of flammable or toxic gases.

**8.0 CERTIFICATION OF APPLICABILITY
OF SUBSTANTIAL HARM CRITERIA**

Facility Name: The Boeing Company, Santa Susana Field Laboratory
Facility Address: 5800 Woolsey Canyon Road, Simi Valley, CA 93063

1. Does the facility transfer oil over water to or from vessels and does the facility have a total oil storage capacity greater than or equal to 42,000 gallons?
Yes No
2. Does the facility have a total oil storage capacity greater than or equal to 1 million gallons and does the facility lack secondary containment that is sufficiently large to contain the capacity of the largest aboveground oil storage tank plus sufficient freeboard to allow for precipitation within any aboveground oil storage tank area?
Yes No
3. Does the facility have a total oil storage capacity greater than or equal to 1 million gallons and is the facility located at a distance such that a discharge from the facility could cause injury to fish and wildlife and sensitive environments? For further description of fish and wildlife and sensitive environments, see Appendices I, II and III to DOC/NOAA's "Guidance for Facility and Vessel Response Plans: Fish and Wildlife and Sensitive Environments and the applicable Area Contingency Plan.
Yes No
4. Does the facility have a total oil storage capacity greater than or equal to 1 million gallons and is the facility located at a distance such that a discharge from the facility would shut down a public drinking water intake?
Yes No
5. Does the facility have a total oil storage capacity greater than or equal to 1 million gallons and has the facility experienced a reportable oil spill in an amount greater than or equal to 10,000 gallons within the last 5 years?
Yes No

Certification

I certify under penalty of law that I have personally examined and am familiar with the information submitted in this document, and that based on my inquiry of those individuals responsible for obtaining this information, I believe that the submitted information is true, accurate, and complete.

Signature 

Name: Thomas Gallacher

Title: Director,
Santa Susana Field Laboratory

Date: 3-26-12

APPENDIX A

Boeing Emergency Response Equipment

**TABLE 1 – EMERGENCY RESPONSE EQUIPMENT
STORAGE LOCATIONS**

1. Central Storage - Building 1407, Hazardous Waste Staging Area (HWSA)
2. Auxiliary Storage (cabinets located as indicated below) - In areas with a potential for accidental releases involving significant volumes of oil or hazardous substances.
 - a) B/4011 Hazardous Waste Staging Area (HWSA)
 - b) SPA Hazardous Waste Staging Area (HWSA)
 - c) Area I GET System Building
 - d) SSFL Fire Station

Periodic inspections ensure that the material inventory is maintained. Fire extinguishers are inspected in accordance with state and local regulations. Equipment maintenance schedules are adhered to. Instrumentation is calibrated as required to comply with operation and accuracy requirements.

**TABLE 2 – EMERGENCY RESPONSE EQUIPMENT INVENTORY
BUILDING 1407 HWSA**

Item	Avg. Quantity
Air Purifying Respirators	3 each (Contracted hazardous waste personnel)
Chemical Monitoring Equipment	SSFL Health & Safety, PID and Multi-gas Analyzers (Located in B/1436)
Chemical Protective Boots	1 pair
Chemical Protective Gloves	22 boxes Nitrile
Chemical Protective Suits	50 each Tyvek
Face Shields	1 each
First Aid Kits/Stations	SSFL Fire Department (primary) and HWSA Bldg. 1407
Hard Hats	All personnel working in non-office areas
Plumbed Eye Wash Stations	HWSA Bldg. 1407, 2 each; HWSA SPA and HWSA Bldg. 4011, 1 each
Portable Eye Wash Kits	1 each
Respirator Cartridges	1 case - Particulates P95, P100, R100
Safety Glasses/Splash Goggles	8 pair
Safety Showers	HWSA Bldg. 1407, 2 each; HWSA SPA and HWSA Bldg. 4011, 1 each
Absorbents	17 bags chemical/oil
Decontamination Equipment	Portable and fixed rinsing equipment and rinseate collection
Emergency Tanks	1 each 250 gallon tote
Overpack Drums	5 each 95 gallon

Miscellaneous Items

Plastic bags, brooms, scrub brushes, dust pans, drum dolly, hoses, ladders, pails w/lids, pH paper, pliers, electric pumps, hand pumps, rope, screw drivers, shovels, Vacuum, Visqueen, wire cutters, pipe wrenches, bung wrench, crescent wrenches, socket wrenches, end and box wrenches

**Table 3 – Emergency Response Equipment Inventory
 Auxiliary Storage Areas (each cabinet)**

Item	Avg Quantity
Faceshield	1
Nitrile Gloves	2 prs
XL poly tyvex suit	2
Poly liquid hand pump	1
Fire Extinguisher (outside cabinet)	1
Miscellaneous Items	Brooms, dust pan, pail w/lid, pH paper, shovel, hose

APPENDIX B

**Notification Procedures
for Environmental Regulatory Agencies**

NOTIFICATION PROCEDURES FOR ENVIRONMENTAL REGULATORY AGENCIES

PRINCIPAL FEDERAL REQUIREMENTS

1. Comprehensive Environmental Response, Compensation and Liability Act of 1980, as amended in 1986, by the Superfund Amendments and Reauthorization Act. (42 USC 9601, et seq.).

A release of a “reportable quantity” of a hazardous substance must be reported to the **National Response Center under the National Contingency Plan**. (40 CFR, Part 300). The toll free number for reporting a release is **(800) 424-8802 or (202) 267-2675**. An owner or operator of a facility or vessel with knowledge of an unauthorized release must immediately report it. Reportable quantities are identified in 40 CFR 302.3 and 4.

Pursuant to 42 USC 9603(b)(3), failure to notify the National Response Center in the event of a release, or the knowing submission of false information, is punishable by a fine or imprisonment of not more than three years, or five years for a second offense.

2. Clean Water Act (33 USC 1251 et seq.).

The release of oil and hazardous substances, in “reportable quantities,” must be made in a manner consistent with the National Contingency Plan (33 USC 321(b)(5); 40 CFR Part 300). A notification requirement for the release of “reportable quantities” is similar to the “Superfund” release reporting requirements of Section 103 of CERCLA. Reportable quantities are identified at 40 CFR 302.4 or are amounts which violate water quality standards or which cause sheen on or the discoloration of water. Reports are made to the **National Response Center, (800) 424-8802 or (202) 267-2675**.

3. Resource Conservation and Recovery Act (42 USC 6901, et seq.).

Discharges of hazardous wastes during transportation must be reported by incident report (DOT Form 5800.1) to the **United States Department of Transportation** within 30 days after discovery of the discharge. Notification must be made by the transporter to the **National Response Center**, at **(800) 424-8802 or (202) 267-2675**, if there is a death, injury requiring hospitalization, property damage in excess of fifty thousand dollars, a radioactive release, or other situation that “should be reported” (40 CFR 263.30(c)(1)).

Releases of hazardous wastes from permitted TSD facilities or from generators of hazardous wastes who accumulate hazardous wastes on-site are made through the facility’s Emergency Coordinator, a position required to be identified under the Waste Management Regulations. A release of hazardous wastes will trigger a requirement for the activation of alarms and communication systems and notification, “if appropriate,” or if assistance is needed, to state or local agencies (40 CFR 264.56(a)). If human health and safety, property, or the environment is threatened by a release, the **National Response Center**, at **(800) 424-8802 or (202) 267-2675**, must be notified by telephone.

Within 15 days after the initial release response, a facility owner or operator must submit a written report to the **US EPA** providing details of the release (40 CFR 264.56(j)).

PRINCIPAL CALIFORNIA STATE REQUIREMENTS

1. Porter-Cologne Water Quality Control Act (Water Code 13000, et seq.).

Releases of reportable quantities of hazardous substances or sewage to waters of the state, including groundwater, must be immediately reported to the **California Emergency Management Agency** at **(800) 852-7550**.

Notification must be made as soon as there is knowledge of the discharge and notification becomes possible (Water Code Section 13271(a)). Notification to the National Response Center may substitute for local state notice.

2. Hazardous Waste Control Law (Health & Safety Code, Section 25100).

Release reporting under California's Hazardous Waste Control Law is similar to that under the Resource Conservation and Recovery Act (22 CCR, 66563, et seq.). Notification is made to the **California Emergency Management Agency** at **(800) 852-7550**.

3. Above Ground Storage Tank Act (Health & Safety Code 25270, et seq.).

The **California Emergency Management Agency**, at **(800) 852-7550**, and **CUPA**, at **(805) 654-2813**, must be immediately notified upon discovery of any spill or release of 42 gallons or more of crude oil or any of its fractions (Health & Safety Code 25270.8). Notice should also be made to the State Water Resources Control Board, the Regional Water Quality Control Board, or the Department of Fish & Game.

4. Waters Bill or Health & Safety Code 25500, et. seq.

The release or spill of "hazardous materials" must be verbally reported immediately by the handler of the material to the responsible local or state regulatory agency and to the Office of Emergency Services, if it poses a significant or potential hazard to health or safety, property, or the environment (Health & Safety Code 25507(a) and 19 CCR 2703). The **California Emergency Management Agency**, at **(800) 852-7550**, and the **Ventura County CUPA**, at **(805) 654-2813**, are the agencies requiring notification. Notice of the release must include the location, the name of the person making the report, the materials involved, an estimate of their amount, and the potential or actual hazards present.

MISCELLANEOUS REQUIREMENTS

SARA, Title 3 (Emergency Planning and Community Right to Know Act), Emergency Release Reporting (42 USC 11001, et seq.).

In addition to the release reporting requirements of "Superfund", Section 103, and the requirements of state law, the unauthorized discharge or release of extremely hazardous substances or other substances above a reportable quantity must be reported in accordance with Part 304 of SARA, 42 USC 11004(a).

Reports are made to the **Region 9 U.S. EPA**, at **800-300-2193**, and to the **California Emergency Management Agency**, at **800-852-7550**. Report name of substance released, whether or not it is listed as an extremely hazardous substance, quantity released, time and

duration of the release, location and environmental media impacted, known or potential health risks, precautions taken, and name and telephone number of reporting person. A written follow-up or detailed response action is also required (42 USC 11004(b)(2)). The form for follow-up reports is found at 19 CCR 2705(b).

BOEING COMPANY REQUIREMENTS

A verbal report to the Boeing Company Insurance Office in case of any significant hazardous material release.

All releases of hazardous substances are required to be reported to SSFL Environmental Protection.

SUMMARY OF RELEASE REPORTING

California Emergency Management Agency (CEMA), California Environmental Protection Agency (Cal/EPA), California Highway Patrol (CHP), California Department of Toxic Substances Control (DTSC), National Response Center (NRC), Regional Water Quality Control Board (RWQCB), Ventura County Environmental Health (VCEHD), Ventura County Fire Department (VCFD)

Federal Requirement	Releases	Notices
CERCLA "Superfund"	Hazardous substances in reportable quantities (excluding petroleum products)	<ul style="list-style-type: none"> • NRC (800) 424-8802
SARA, Title 3	CERCLA releases and other extremely hazardous releases (40 CFR 355)	<ul style="list-style-type: none"> • NRC (800) 424-8802 • US EPA 800-300-2193 • CEMA (800) 852-7550 • VCEHD, (805) 654-2813
Clean Water Act	Hazardous Substances, including petroleum products, in reportable quantities in US waters	<ul style="list-style-type: none"> • NRC (800) 424-8802
RCRA		
Generators, Transporters	Significant releases of hazardous wastes	<ul style="list-style-type: none"> • NRC (800) 424-8802
Water Quality	Hazardous substances in reportable quantities	<ul style="list-style-type: none"> • NRC (800) 424-8802 • DTSC (818) 717-6500 • RWQCB (213) 576-6600
Any Hazardous Substances	Any release of hazardous materials <u>unless</u> no significant hazard to human health and safety, property, or the environment	<ul style="list-style-type: none"> • CEMA (800) 852-7550 • VCFD, Hazmat Section (805) 389-9710 • VCEHD CUPA (805) 654-2813
Highways	Hazardous materials in reportable quantities	<ul style="list-style-type: none"> • CHP (800) 835-5247 • DOT Form 5800.1
Non-Emergency Hazardous Substances	Present and past (when discovered) releases of hazardous substances in reportable quantities, if a significant threat to human health and safety, property, or the environment	<ul style="list-style-type: none"> • DTSC written report within 30 days of discovery; notify first (818) 717-6500

RELEASE REPORTING REQUIREMENTS

Material	Reporting Quantity	Notify
Any hazardous substance	Any release that threatens human health and safety, property, or the environment	CEMA Ventura Co. CUPA
Aluminum sulfate	5,000 lbs (2,270 kg)	NRC Region 9 U.S. EPA CEMA
Hydrochloric acid	5,000 lbs (2,270 kg)	NRC Region 9 U.S. EPA CEMA
Petroleum and fractions	42 gallons, threat to US waters, or sheen on US waters	NRC CEMA Ventura Co. CUPA
Potassium Permanganate	100 lbs (45.4 kg)	NRC Region 9 U.S. EPA CEMA
Sodium Hydroxide	1,000 lbs (454 kg)	NRC Region 9 U.S. EPA CEMA
Trichloroethylene	100 lbs (45.4 kg)	NRC Region 9 U.S. EPA CEMA

From 40 CFR 117.3/302.4, CA HSC 25507, CA HSC 25359.4, 19 CCR 2703