

DOE Rapid Operational Validation Initiative (ROVI) Guidance for Data Collection from Li-ion Systems

Last Revised July 7, 2023

Contents

- 1. Introduction 3
- 2. System Metadata 4
 - 2.1 System Metadata Excel Sheet 4
 - 2.2 System Physical Layout..... 7
 - 2.3 Power Meter Layout..... 7
 - 2.4 Auxiliary Load Meter Layout 9
 - 2.5 Protection Component Layout 9
 - 2.6 Vendor Data Sheets..... 10
 - 2.7 Other 11
- 3. System Streaming Data 12
 - 3.1 Streaming Data Points During Standard Operation 12
 - 3.2 Fault-Triggered Data Collection..... 15
 - 3.3 Streaming Data Communications Protocols 16
- 4. Event and Maintenance Data 19
- 5. System Commands 23
- 6. Reference Performance Tests (RPTs) 24
 - 6.1 Schedule for Energy Capacity Test at rated power 24
 - 6.2 Schedule for Energy Capacity Test at half the rated power 25
 - 6.3 Schedule for Pulse Test 26
 - 6.4 Schedule for PV Firing..... 27
 - 6.5 Schedule for Frequency Regulation 28
 - 6.6 Schedule for Standby Energy Loss..... 29
 - 6.7 Timeline for Reference Performance Tests 30
- 7. Data Request Checklist..... 32

1. Introduction

The DOE Energy Storage Grand Challenge Rapid Operational Validation Initiative (ROVI) is intended to address critical gaps in data needs to evaluate energy storage, such as the lack of access to large and uniform sets of performance data that are necessary to accelerate the pace at which technology development can occur. ROVI's overall focus is to accelerate the time from lab to market for new energy storage technologies by employing data-driven tools to predict their operational lifetimes. The data will also be used to develop accelerated testing and validation methods for new technologies. To achieve these goals, ROVI will collect data from Long Duration Energy Storage (LDES) systems awarded funding from certain DOE programs. For example, DE-FOA-0002867, Bipartisan Infrastructure Law Long-Duration Energy Storage Demonstrations, notes that

“In order to fulfill statutory objectives for reporting and testing and validation requirements outlined in the BIL and Energy Act of 2020, OCED will leverage the Rapid Operational Validation Initiative to collect quality data from deployments funded by the BIL provisions.”

This document outlines the ROVI expectations for data collection from these deployed systems, specifically Li-ion systems. Reporting requirements are outlined for four types of data/metadata: 1) system metadata; 2) streaming data; 3) event and maintenance data; 4) system commands/schedules. Additionally, this document details protocols for periodic reference performance tests to assess system state of health.

2. System Metadata

System metadata is to be reported to the ROVI team within two months of the project start. This involves uploading the following documents to a ROVI-designated shared drive:

- 1) Completed system metadata Excel sheet
- 2) System physical layout
- 3) Power meter layout
- 4) Auxiliary load meter layout
- 5) Protection component layout
- 6) Vendor data sheets

Additional details on each of these reporting requirements are noted below.

2.1 System Metadata Excel Sheet

Metadata is essential for organizing data streams from different deployment projects. Table 1 provides a copy of the information requests in the System Metadata Excel Sheet. In lieu of filling out this table, the project performer may also share vendor data sheets with the relevant information. The ROVI team will then complete this table on the project performer's behalf and follow up with requests for any missing metadata.

Table 1. Li-ion system metadata requests.

Metadata	Unit	Value	Description
<i>General System Specifications</i>			
Rated power	kVA		
Rated energy	kWh		Provide power at which Rated Energy is measured.
Min operating temperature	C		
Max operating temperature	C		
Preferred operating temperature window (lower to upper bound)	C		
Max SOC (operating limit)	percent		
Min SOC (operating limit)	percent		

Table 1. Li-ion system metadata requests (continued).

Metadata	Unit	Value	Description
Power Conversation System (PCS) Specifications			
Power conversion system rated power	kVA		For each PCS
AC/DC bidirectional inverter rated power	kVA		For each inverter
AC/DC bidirectional inverter rated voltage (in/out)	V		For each inverter
AC/DC bidirectional inverter rated current	A		For each inverter
DC/DC bidirectional converter rated power	kW		For each converter
DC/DC bidirectional converter rated voltage	V		For each converter
DC/DC bidirectional converter rated current	A		For each converter
# of DC/DC converters	--		For each PCS
# of AC/DC inverter	--		For each PCS
Rack Specifications			
Total # (y) modules in series in rack with xPyS configuration	--		
Total # (x) modules in parallel in rack with xPyS configuration	--		
# racks in series in container	--		
# racks in parallel in container	--		
External dimensions (l x w x h)	m		
Module Specifications			
Total # (y) cells in series in module with xPyS configuration	--		
Total # (x) cells in parallel in module with xPyS configuration	--		
External dimensions (l x w x h)	mm		
Applied pressure	psi		If applicable

Table 1. Li-ion system metadata requests (continued).

Metadata	Unit	Value	Description
Cell Specifications			
Cathode chemistry			
Anode chemistry			
Electrolyte chemistry			optional
Nominal capacity	Ah		
Nominal voltage	V		
Cell external packaging dimensions (l x w x h)	mm		
Weight	g		
Max charge current	A		
Standard charge current	A		
Max discharge current	A		
Standard discharge current	A		
Operational voltage limits (lower to upper bound)	V		
Allowed temperature window during charge (lower to upper bound)	C		
Allowed temperature window during discharge (lower to upper bound)	C		
Specific energy	Wh/kg		
Energy density	Wh/L		
Electrode stack - length	mm		
Electrode stack - width	mm		
Electrode stack - thickness	mm		
Thermal Management System			
Method of thermal management	--		e.g., liquid cooling, overhead fans, etc.
Heat convection rate	W/m ² -K		
Component Manufacturers + Product IDs			
Cell	Name/ID		
Module	Name/ID		
Rack	Name/ID		
Battery management system	Name/ID		
Thermal management system	Name/ID		
Power conversion system or inverter	Name/ID		
Transformer	Name/ID		
HVAC	Name/ID		
Container	Name/ID		
Contactors	Name/ID		
Cabling	Name/ID		

The project performer should also note any planned operating constraints for the system, such as bounds on SOC, temperature, etc.

2.2 System Physical Layout

Diagrams of the system will assist in the development of 3D models that allow the identification of location-specific issues in containers (e.g., inadequate cooling that is impacting the performance of racks in one corner of the container). The diagrams of the system provided to the ROVI team should include the information noted in Table 2. These diagrams will preferably be shared as CAD or BIM files.

Table 2. Elements to include in system diagrams.

System Diagram Elements	Notes
Dimensions	
Location of battery racks in the container	
Location of HVAC components in the container	
Location of power electronics in the container	
Location of all thermal sensors	
Location of any additional sensors	E.g., gas detection
Layout of streaming data label vs. container number and location of component in container	Components include racks, modules, etc. If there are elements labeled Rack 1 and 2 in the data stream, we should know where they are in the container.

2.3 Power Meter Layout

The ROVI team is requesting documents that map the measurements from power meters in the streaming data to points on a power flow diagram. This information will provide essential context for power measurements.

The following descriptions provide three examples of potential power meter layouts, mapped against points in power flow diagrams in Figure 1. Each of these scenarios presents a different configuration, illustrating how power is measured at various points in the energy storage system.

Example 1: In this layout, a single DC battery power meter measures the DC power flow from the DC battery to the bi-directional inverter (P_{bat}). This power is subsequently measured at the PCS power meter as it exits the inverter (P_{PCS}). The power is then split off and measured at an auxiliary power meter for the auxiliary loads (P_{aux}). Another portion is directed to the transformer, measured at a separate power meter (P_{trans}). Exiting the transformer, the power flow is measured at the grid power meter (P_{grid}) before finally being delivered to the grid.

Example 2: In this layout, a DC power meter measures the DC power flow out of the DC battery (P_{bat1}). This power splits off into two streams. One portion is measured at the auxiliary power meter (P_{aux}), and the other portion is measured as it enters the bi-directional inverter (P_{bat2}). The power leaving the inverter is

measured by the PCS power meter before it goes into the transformer (P_{PCS}). The power exiting the transformer and feeding into the grid is measured at the grid power meter (P_{grid}).

Example 3: In this layout, a DC power meter measures the DC power flow from the battery to the bi-directional inverter (P_{bat}). The PCS power meter then measures the power flowing from the inverter to the transformer (P_{PCS}). The grid power meter captures the power flow from the transformer to the grid (P_{grid}). In this configuration, the auxiliary load is measured at the auxiliary power meter (P_{aux}), but comes from the grid via a separate line.

The project performer should provide a power meter layout similar to the examples in Figure 1. For all cases, the various levels at which power flow is measured are:

- P_{grid} (upstream¹ of transformer)
- P_{trans} (downstream of transformer)
- P_{pcs} (upstream of bi-directional inverter)
- P_{aux} – measure auxiliary load
- P_{bat} (upstream of DC Battery)
 - For Example Case 2, P_{bat1} is measured just upstream of DC battery, P_{bat2} is measured upstream of the point at which power flows to auxiliary load

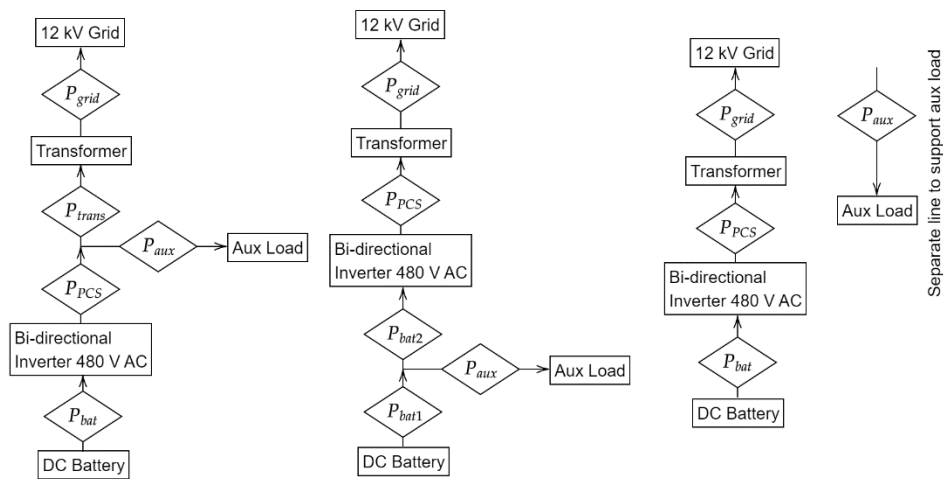

Figure 1. Example cases (1 to 3, left to right) of power meter layouts.

¹ Upstream is towards grid, downstream is away from grid

2.4 Auxiliary Load Meter Layout

The auxiliary load meter layout will provide essential context for power measurements and should be noted in an electrical line diagram. Table 3 provides example auxiliary loads that may be considered in the electrical line diagram. Some additional examples are found in the following references.²

Table 3. Auxiliary loads to consider in the electrical line diagram.

Auxiliary Load Component	Notes
HVAC	
Pumps	If there is liquid cooling
Lighting inside container/cabinet	
Fire suppression system	
Power to the BMS	
Power the site manager (EMS)	For example, computers, controls, AC, lighting for the cabin/room in which EMS located
Data storage and transfer	For example, power industrial computers to share data

2.5 Protection Component Layout

The protection component layout will provide essential context for events and faults in the BESS and should be noted in an electrical line diagram. Table 4 provides example protection components that may be considered in the electrical line diagram. Some additional examples are found in the following references.³

² Examples of auxiliary load meter layouts: 1. <https://energystorage.pnnl.gov/pdf/PNNL-28480.pdf> Figure A.9; 2. <https://energystorage.pnnl.gov/pdf/PNNL-28379.pdf> Figure A.1; 3. <https://energystorage.pnnl.gov/pdf/PNNL-28478.pdf> Fig. 3, Fig. A.3, Fig. A.4; 4. <https://www.pterra.com/our-projects/auxiliary-metering-for-besspv-installations/>; <https://www.sandia.gov/ess-ssl/publications/SAND2014-2883.pdf> Figure 3

³ Examples of protection components in electrical line diagrams: 1. <https://library.e.abb.com/public/98f8a60a51614e81baff97c9b2a4af83/Battery%20Energy%20Storage%20Components%20for%20the%20OEM%20Presentation.pdf>; 2. <https://www.sandia.gov/ess-ssl/publications/SAND2014-2883.pdf> Figure 2; 3. <https://energystorage.pnnl.gov/pdf/PNNL-28478.pdf> Fig. 3, Fig. A.3, Fig. A.4.

Table 4. Protection component layout.

Level	Component	Comments
Module	Fuse	If modules connected in series, only one fuse needed at rack level. If connected in parallel, each module needs a fuse.
DC Rack Level	Fuse, contactor, circuit breaker, relay, switch (may not have all of these items)	Racks may be connected in series, in parallel, or in series/parallel. If racks connected in series, only one of each item needed at rack level. If connected in parallel, each rack would need these items.
DC BESS (on the DC side of the bi-directional inverter)	Fuse, circuit breaker, contactor, relay, switch, surge protector (may not have all of these items)	
AC side of the bi-directional inverter	Fuse, circuit breaker, contactor, relay, switch, surge protector (may not have all of these items)	

2.6 Vendor Data Sheets

The project performer is to provide vendor data sheets for all components for which they are available, especially the cells, module/rack, battery management system, converter, inverter, thermal management system, and overall BESS.

The cell data sheet would preferably include the following information:

- Cell voltage vs. discharge capacity at various currents and temperatures
- Voltage vs. time at various currents
- Cycle life: Discharge capacity vs. cycle number at several cycling conditions
- Calendar life: Discharge capacity vs. storage time
- Self-discharge: Voltage vs. storage time at various voltages
- Internal resistance measurements
- Any other standard cell specs provided to the customer

The inverter data sheet would preferably include the following information:

- Temperature rating (power vs. temperature)
- Altitude rating (power vs. altitude)
- Nominal capability curve (P (MW) vs. Q (MVar))
- Any other standard inverter specs provided to the customer

The system data sheet would preferably include the following information:

- Discharge energy at various SOC (at various discharge powers)
- Any other standard system specs provided to the customer

2.7 Other

The ROVI team may require other system metadata over the course of the project. The ROVI team and the project performer will discuss these new requests with the DOE. The project performer will provide the metadata in the specified format if the request is deemed reasonable.

3. System Streaming Data

The following section details the streaming data points that the ROVI team is requesting and the communications protocols according to which the project performer may share the data with the ROVI team.

3.1 Streaming Data Points During Standard Operation

Table 5 provides a copy of the data point specifications in the Streaming Data Excel sheet. These specifications apply to data collection during normal operating conditions. For all points, discharging should be denoted as positive and charging as negative.

The project performer should confirm with the ROVI team and all component manufacturers that they will be able to supply each of the data points at the requested rate and resolution. Additionally, the project performer should notify the ROVI team if they plan to use any additional sensors in the system (e.g., gas detection). The ROVI team may also request the streaming data from these sensors.

Table 5. Li-ion system streaming data.

Data Point	Units	Sample Rate Minimum (sample/s)	Values	Notes
System Level				
Time		1	value	ISO 8601 format
Power at Point of Connection with Grid	kW	1	value	see meter layout diagram
Reactive Power at Point of Connection with Grid	kVAR	1	value	see meter layout diagram
Power Factor at Point of Connection with Grid		1	value	see meter layout diagram
AC RMS Voltage (A/B/C)	VRMS	1	value	distinct output for A/B/C
AC RMS Current (A/B/C)	IRMS	1	value	distinct output for A/B/C
Power at Transformer	kW	1	value	see meter layout diagram
Reactive Power at Transformer	kVAR	1	value	see meter layout diagram
Power Factor at Transformer		1	value	see meter layout diagram
AC RMS Voltage (A/B/C) at Transformer	VRMS	1	value	distinct output for A/B/C
AC RMS Current (A/B/C) at Transformer	IRMS	1	value	distinct output for A/B/C
Power Requested (command)	kW	1	value	At what meter does BESS attempt to provide the requested power
Reactive Power Requested (command)	kVAR	1	value	
SOC		1	value	0.01% precision
SOH		1 per day	value	1% precision
Temperature of Air Inside Container	C	1 per min	value	report output for each sensor in container; 0.1C precision
Humidity Inside Container	%	1 per min	value	report output for each sensor in container
Total AC Discharge Energy	kWh	1 per 10 min	value	Recorded at meter or calculation? If at meter, get at each meter.
Total AC Charge Energy	kWh	1 per 10 min	value	Recorded at meter or calculation? If at meter, get at each meter.
Contactor Status	Binary	1	1 = closed, 0 = open	For every contactor
Breaker Status	Binary	1	1 = closed, 0 = open	For every breaker

Table 5. Li-ion system streaming data (continued).

Data Point	Units	Sample Rate Minimum (sample/s)	Values	Notes
Power Conversion System				
Power at PCS	kW	1	value	see meter layout diagram
Reactive Power at PCS	kVAR	1	value	see meter layout diagram
Power Factor at PCS		1	value	see meter layout diagram
AC RMS Voltage (A/B/C) at PCS	VRMS	1	value	distinct output for A/B/C
AC RMS Current (A/B/C) at PCS	IRMS	1	value	distinct output for A/B/C
System Frequency	Hz	1	value	
THD	dBm	1	value	Usually measured at converter level
Contactors Status	Binary	1	1 = closed, 0 = open	For every contactor
Breaker Status	Binary	1	1 = closed, 0 = open	For every breaker
Total DC Discharge Energy	kWh	1 per 10 min	value	Recorded at meter or calculation?
Total DC Charge Energy	kWh	1 per 10 min	value	Recorded at meter or calculation?
DC Power	kW	1	value	For each PCS
DC Voltage	V	1	value	For each PCS
DC Current	I	1	value	For each PCS
Temperature	C	1	value	For each PCS; 0.1C precision
String Level (Connected Racks), if part of architecture				
DC Power	kW	1	value	
DC Voltage	V	1	value	
DC Current	A	1	value	
SOC		1		if available at this level, 0.01% precision
Rack Level (if part of architecture)				
DC Power	kW	1	value	
DC Voltage	V	1	value	
DC Current	A	1	value	
Temperature	C	1	value	0.1C precision
SOC		1	value	0.01% precision
SOH		1 per day	value	1% precision

Table 5. Li-ion system streaming data (continued).

Data Point	Units	Sample Rate Minimum (sample/s)	Values	Notes
Module Level (if part of architecture)				
DC Power	kW	1	value	
DC Voltage	V	1	value	
DC Current	A	1	value	
Temperature	C	1	value	0.1C precision
SOC		1	value	0.01% precision
SOH		1 per day	value	1% precision
Cell Level				
DC Power	kW	1	value	
DC Voltage	V	1	value	
DC Current	A	1	value	
Temperature	C	1	value	
SOC		1	value	1% precision
Auxiliary Systems				
Auxiliary System Power	kW	1	value	For every auxiliary meter
Auxiliary System Reactive Power	kVAR	1	value	For every auxiliary meter
HVAC/Thermal Control Power	kW	1	value	
External Conditions				
Outside Temperature	C	1 per min	value	0.1C precision
Outside Dew Point Or Humidity %	C	1 per min	value	
Precipitation	mm	1 per min	value	
Solar Irradiance	W/m2	1 per min	value	
Battery Management System				
Balancing	binary	1	1 = on; 0 = off	At all hierarchies

The cell-level streaming data specifications may be adjusted based on the standard statistical quantities output by the battery management system.

3.2 Fault-Triggered Data Collection

Grid anomalies under energy storage testing and operation can be anticipated. While the expectation is that the energy storage technology should be able to perform corrective actions (disconnection,

deactivation, ride-through, etc.), having data to understand the event and the implication on operations is critical. Digital fault recording technology has been present in many technologies and is generally used for recording of system events and monitoring system protection performance.⁴ These fault recording systems are also integrated into larger energy storage systems (Trevizan 2022) to establish explanations for system trips and sudden changes in performance.⁵ These systems collect data at much higher resolution continually but only provide this data upon a poll. The ROVI team requests that a digital fault recorder able to collect data at a minimum of 1 ms data resolution be installed to capture system transients. Data recorded includes AC side voltage and current.

3.3 Streaming Data Communications Protocols

The following section outlines two options for the project performer to provide streaming data to the ROVI team based on existing common methods for sharing data from a BESS:

1. ROVI connects to existing vendor communication adapter
2. ROVI connects to existing vendor cloud services

The project performer should select one of these methods for sharing data with the ROVI team and address any additional questions listed for that method. The project performer should immediately notify the ROVI team if neither of these data sharing protocols work for them.

Method 1: ROVI connects to existing vendor communication adapter

- In this method (Figure 2), the project performer will directly stream the data in real time or collect data locally in a historian and stream in a batch mode through a 'vendor-owned' communication adapter
- The Energy Management System (which has access to the requested streaming data points) will be collecting data into a historian independent of the communication module connected to the utility
- The ROVI team will provide the endpoints and Rest API methods
- 'Vendor-owned' communication adapter will adhere to the RestAPI documentation that will be provided before the commissioning of the BESS system.
- A responsibility matrix will be established between the ROVI team and the project performer (in terms of ownership and protocols for communication) for guaranteed service to ensure minimal loss of data
- The project performer provides the communication adapter to communicate to the Rest API
- The process for token exchange to be used by the system performer as trust certificate when pushing the data will be defined with sufficient rotation periods (up to 5 minutes)

⁴ J. Perez, "A guide to digital fault recording event analysis," 2010 63rd Annual Conference for Protective Relay Engineers, College Station, TX, USA, 2010, pp. 1-17.

⁵ R. D. Trevizan, J. Obert, V. De Angelis, T. A. Nguyen, V. S. Rao and B. R. Chalamala, "Cyberphysical Security of Grid Battery Energy Storage Systems," in IEEE Access, vol. 10, pp. 59675-59722, 2022.

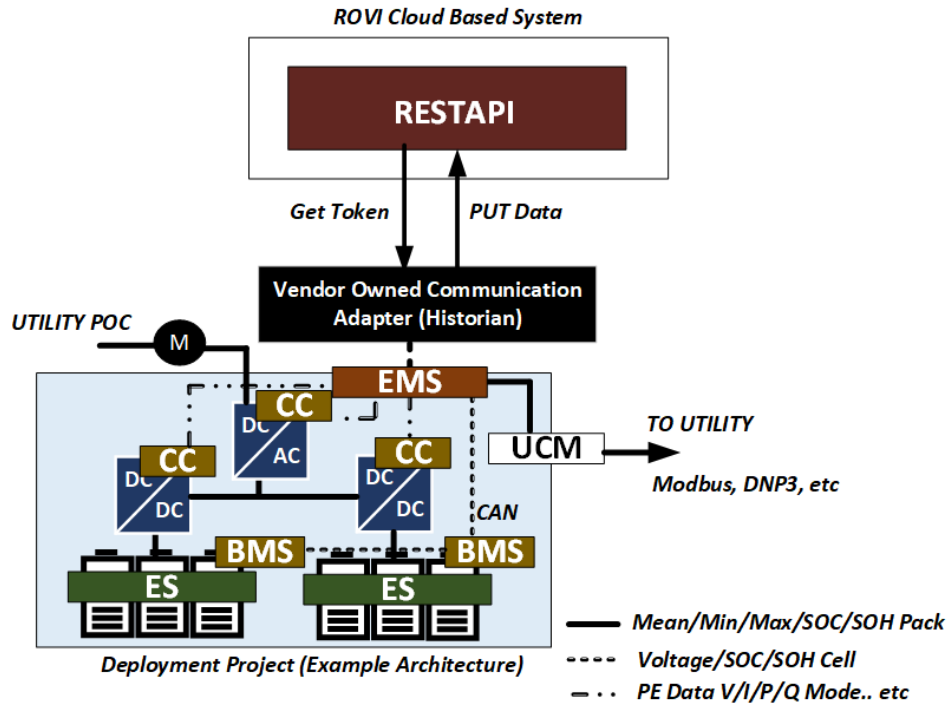

Figure 2. ROVI connects to existing vendor communication adapter.

Method 2: ROVI connects to existing vendor cloud services

- In this method (Figure 3), the vendor will directly stream the data from their 'vendor-serviced' cloud system to the ROVI cloud system
- Similar to method 1, the data will be streamed across the cloud services in either continuous or batch mode
- The Vendor Cloud System will provide an adapter to communicate to the ROVI Cloud system using Rest API
- The ROVI team will provide the Endpoints and Rest API methods
- RestAPI documentation for vendors to follow will be provided before the commissioning of the BESS system.
- A responsibility matrix will be established between the ROVI team and the project performer (in terms of ownership and protocols for communication) for guaranteed service to ensure minimal loss of data
- The process for token exchange to be used by the system performer as trust certificate when pushing the data will be defined with sufficient rotation periods (up to 5 minutes)

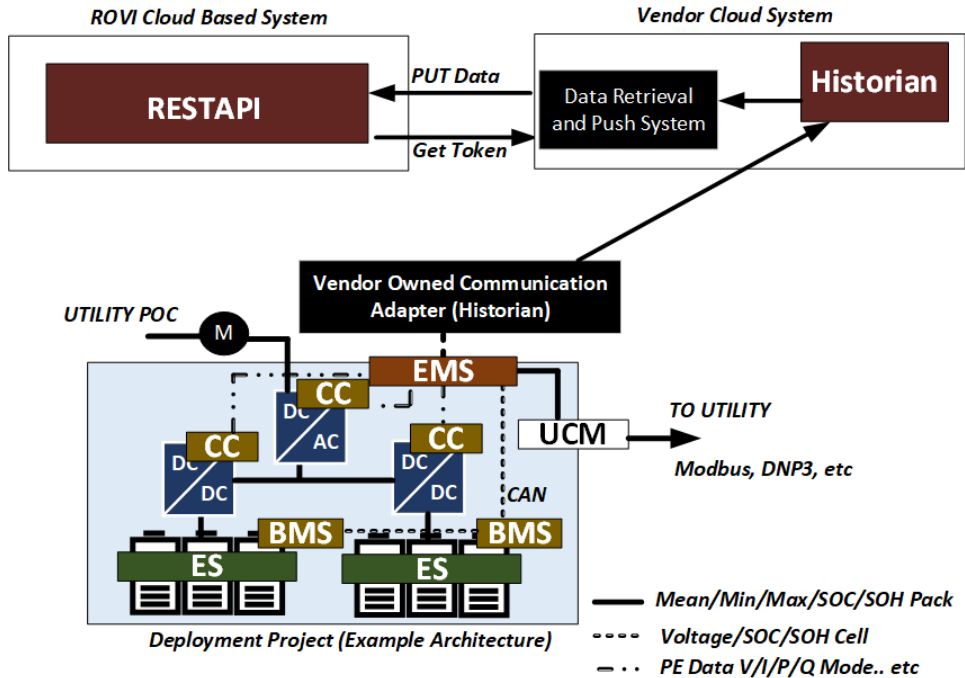

Figure 3. ROVI connects to existing vendor cloud services.

4. Event and Maintenance Data

Streaming data alone does not provide adequate context for the events (planned and unplanned) that impact system performance. The following section details the system event and maintenance information that the ROVI team is requesting and the methods according to which the project performer may share the data with the ROVI team. An event is defined as anything that causes the system or a particular subsystem/component to be taken offline, replaced, or updated.

Table 6 (reproduced from the Event and Maintenance Log Excel file) details the minimum information that the ROVI team expects to receive whenever an event occurs and a system maintenance action is carried out. The ROVI team should be notified with the event information, component information, and event description within two business days of an event occurring. The ROVI team should be notified of the resolution within two business days of a maintenance action being taken.

The project performer will share this information with the ROVI team by filling out the Operations & Maintenance Written Log Excel file within a ROVI-designated shared drive.

Alternatively, this information may be shared via an existing maintenance tracking software that the project performer intends to use. This will be discussed during the development of the project work plan.

The ROVI team may require other event and maintenance descriptions over the course of the project. The ROVI team and the project performer will discuss these new requests with the DOE. The project performer will provide the event and maintenance description in the specified format if the request is deemed reasonable.

Table 6. Events and maintenance activity log.

Event #	Event Information			Component Information		Event Description		Resolution						
	Planned vs Unplanned	% System Rated Power Unavailable	Event Category (see options)	Component (see options)	Additional Component Details? (e.g., associated streaming label in system diagram)	Event Start Time (ISO 8601 format)	Short Event Description	Root Cause	Solution	Event Resolution Time (ISO 8601 format)	Event Duration (x days, y hours, z minutes)	Related to Previous Event #	Enter outage duration if less than event duration	Additional Details (provide version ID# if standard firmware update)
1	Unplanned		Hardware	Battery	Container 2, Rack 12	2/2/2020 0:00				3/13/2020 11:01	40 days, 11 hours, 1 minutes	none	3 days	
2	Unplanned		Firmware / Software	Database issue		7/17/2020 0:00	Database software crash	firmware issue / update firmware with vendors help.		7/20/2020 0:01	3 days, 0 hours, 1 minutes	1		
3	Planned		Firmware / Software	Update										BMS upgraded to Version 11.2
4	Planned		Hardware	Battery			Replace bad module							

The options for the Event Category column are: Hardware, Firmware/Software, Network, and External. The component options for each of the event categories are noted in Table 7-10 below. These options are taken from the Electric Power Research Institute (EPRI) Operations and Maintenance Tracker.⁶

⁶ <https://www.epri.com/research/products/00000003002019222>

Table 7. Hardware event category components.

Hardware	Notes
Battery	Catch all for the part of the system that is storing the electrical energy in another form
Inverter	Bi or mono-directional AC-DC converter
Converter	Bi or mono-directional DC-DC converter
Thermal management	Anything related to HVAC
Electrical conductor	Only conductors used for moving energy in/out of storage system (excludes comms or auxiliary conductors)
Energy management system	High level system controller typically used to orchestrate the operation of many storage devices and inverters
Transformer	Generic transformer. Details about the transformer can be provided in the blue table
Meter	Any device in the system that is measuring and externally reporting data
Battery management system	Controller that manages the operation of a single battery / storage system
Data acquisition (DAQ)	A device which collects and communicates data from many different metering devices, but does not necessarily measure data directly
Database	A repository for historical system data
Network equipment	
Uninterruptible power supply	
Fire detection or suppression systems	

Table 8. Firmware/software event category components.

Firmware/Software	Notes
Update	
Error	Bug in firmware requiring update
Database issue	

Table 9. Network event category components.

Network	Notes
Data transfer error	
Device failure	
Internet service provider error	
Local area network error	
VPN error	
Firewall error	
Physical disconnection	
Cloud service outages	

Table 10. External event category components.

External	Notes
Loss of grid power	
Loss of auxiliary power	
Weather/natural causes	Earthquake, thunderstorm, pandemic, rodents, corrosion, erosion
Operator error	
External tampering	Vandalism
Site access issues	

5. System Commands

Understanding system performance requires comparison of the command issued to the BESS with the action ultimately taken. To this end, the ROVI team requests a time-stamped charge/discharge schedule for the system that details the power/reactive power command and any conditional logic. This would ideally be provided as part of the streaming data (see Table 3 - entries for power and reactive power requested). The project performer should notify the ROVI team if this information cannot be shared as streaming data.

6. Reference Performance Tests (RPTs)

The execution of standard test protocols is essential for assessing the state of health of a system over time. The project performer will execute the following system reference performance tests (energy capacity, pulse, PV firming, frequency regulation, and standby energy loss) at specified times throughout the year. The resulting data will be shared with the ROVI team via the previously described approaches for streaming data and system commands.

The frequency of certain RPTs may be reduced if equivalent data is collected during normal operation over the course of the year. Additionally, there is flexibility in the timing of RPTs so that the BESS is not exercised to the detriment of the grid.

6.1 Schedule for Energy Capacity Test at rated power

This test is done twice a year: at the start of operations and every six months thereafter. Document Li-ion RPT 070723.xlsx provides a row-by-row schedule for the energy capacity test at rated power and that information is reproduced below. Figure 4 shows the full protocol over time.

1. Charge the BESS to max SOC as dictated by BMS (which may be < 100% SOC) using recommended charge power⁷, allowing power to taper as dictated by BMS
2. Rest for 20 min (for 10-h duration), 10 min if duration is 24 hours
3. Discharge at rated power to lower SOC limit as dictated by BMS (which may be > 0% SOC)
4. Rest for 20 min (if duration is 10 hours), 10 min if duration is 24 hours
5. Charge the BESS to max SOC as dictated by BMS using recommended charge power, allowing power to taper as dictated by BMS
6. Rest for 20 min (for 10-h duration)
7. Steps 3-6 form one cycle. Repeat steps 3-6 three times.

⁷ It is assumed that the recommended charge power is equal to the rated power. If this is not the case, please adjust the charge duration as indicated in the spreadsheet.

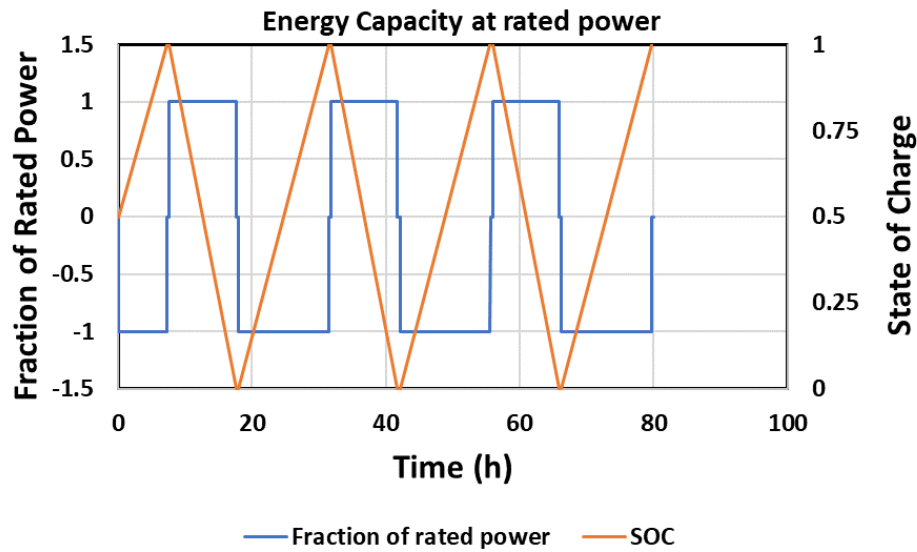

Figure 4. Protocol for energy capacity test at rated power.

6.2 Schedule for Energy Capacity Test at half the rated power

This test is done once a year: at the start of testing and every 12 months thereafter. Document RPT 070723.xlsx provides a row-by-row schedule for the energy capacity test at half the rated power and that information is reproduced below. Figure 5 shows the full protocol over time.

1. Charge the BESS to max SOC as dictated by BMS (which may be < 100% SOC) using recommended charge power, allowing power to taper as dictated by BMS
2. Rest for 20 min (for 10-h duration)
3. Discharge at half the rated power to lower SOC limit as dictated by BMS (which may be > 0% SOC)
4. Rest for 20 min (if duration is 10 hours), 10 min if duration is 24 hours
5. Charge the BESS to max SOC as dictated by BMS using recommended charge power, allowing power to taper as dictated by BMS

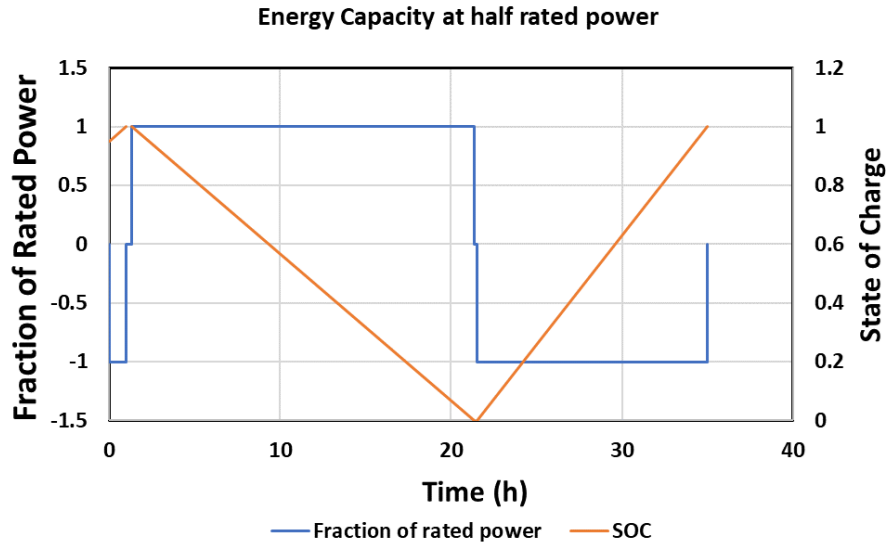

Figure 5. Protocol for energy capacity test at half the rated power.

6.3 Schedule for Pulse Test

This test is done once a year: at the start of testing and every 12 months thereafter. Document RPT 070723.xlsx provides a row-by-row schedule for the pulse test and that information is reproduced below. Figure 6 shows the full protocol over time.

Start at 100% SOC. Measure resistance at Max SOC, 80%, 60%, 40%, 20%, Min SOC, with only discharge pulse at 100% SOC, and charge pulse at 0% SOC, and discharge, charge pulse at other SOC. Rest 30 min between pulses, and after taking BESS to desired SOC.

- Assume discharge pulse applied at rated power. Keep delta SOC for pulse < 0.025% SOC.
- $\text{Rated Power} * (\text{Pulse duration } \Delta T \text{ in hours for 10-h BESS}) = \text{Rated power} * 10\text{h} * 0.00025$
- Pulse duration in hours = 0.0025 hours or 9 sec.
- For same duration of 9 sec, delta SOC for 24-h BESS = 0.010%

1. Take BESS to max SOC per procedure described earlier. Rest for 30 min.
 1. Apply discharge pulse at rated power for 9 sec. Rest 30 min.
2. Take BESS to 80% SOC by discharging at rated power. Rest for 30 min.
 1. Apply discharge pulse at rated power for 9 sec. Rest 30 min
 2. Apply charge pulse at rated power for 9 sec. Rest 30 min

3. Take BESS to 60% SOC by discharging at rated power. Rest for 30 min.
 1. Apply discharge pulse at rated power for 9 sec. Rest 30 min
 2. Apply charge pulse at rated power for 9 sec. Rest 30 min
4. Take BESS to 40% SOC by discharging at rated power. Rest for 30 min.
 1. Apply discharge pulse at rated power for 9 sec. Rest 30 min
 2. Apply charge pulse at rated power for 9 sec. Rest 30 min
5. Take BESS to 20% SOC by discharging at rated power. Rest for 30 min.
 1. Apply discharge pulse at rated power for 9 sec. Rest 30 min
 2. Apply charge pulse at rated power for 9 sec. Rest 30 min
6. Take BESS to min SOC by discharging at rated power. Rest for 30 min.
 1. Apply charge pulse at rated power for 9 sec. Rest 30 min
7. Bring BESS to max SOC. Rest 30 min.

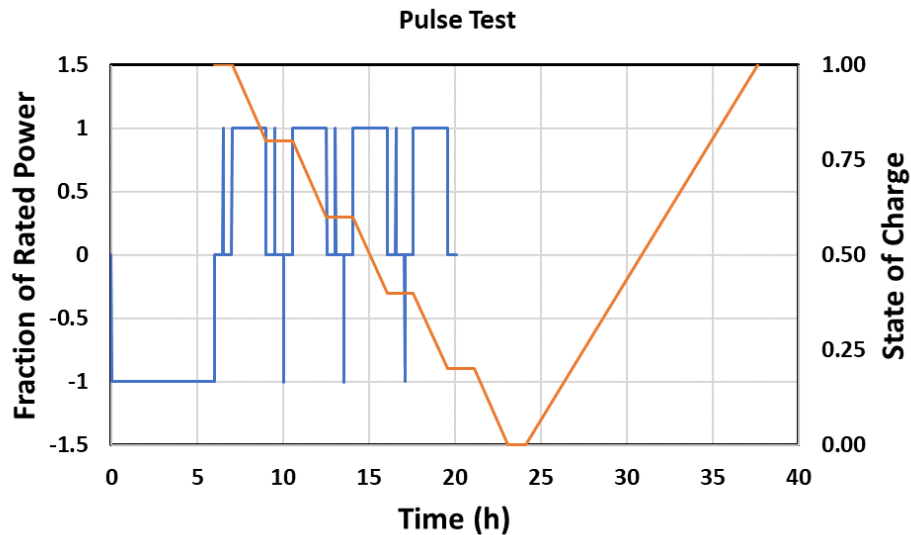

Figure 6. Protocol for pulse test.

6.4 Schedule for PV Firming

This test is done once a year: at the start of testing and every 12 months thereafter. Document RPT 070723.xlsx provides a row-by-row schedule for the PV firming protocol and that information is reproduced below. Figure 7 shows the power commands sent to the BESS as a function of time.

1. Bring BESS to the required starting SOC. Since the duty cycle has a net discharge energy, the start SOC is set at 95% of maximum SOC.
 - a. Charge or discharge the BESS to 95% SOC. Compare the charge or discharge energy to the required energy to bring to start SOC based on the measured energy capacity from the RPT.
 - i. during charge, the charge energy = (Measured discharge energy capacity from RPT)*(95% SOC-BESS SOC)/(SOCmax-SOCmin)/RTE from RPT test
 - ii. during discharge, the discharge energy = (Measured discharge energy capacity from RPT)*(BESS SOC -95% SOC)/(SOCmax-SOCmin)
2. Rest for 20 min
3. Apply the PV Firing signal
4. Rest for 20 min
5. Bring battery back to initial 95% SOC

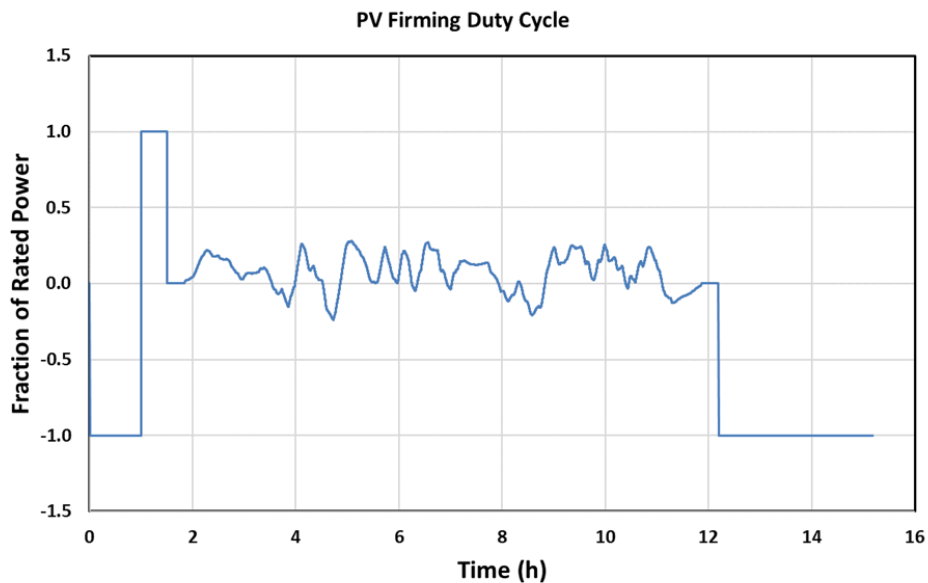

Figure 7. Protocol for PV firming.

6.5 Schedule for Frequency Regulation

This test is done once a year: at the start of testing and every 12 months thereafter. Document RPT 0707233.xlsx provides a row-by-row schedule for the frequency regulation protocol and that information is reproduced below. Figure 8 shows the full protocol over time.

1. Bring BESS to the required starting SOC. Note: since 1 power unit is the rated power, which is the 10-h rate, applying a 24-h energy neutral duty cycle is not expected to have a delta SOC of > 5%. To avoid voltage excursion on charge pulses, the starting SOC is set at 60%.
 - a. Charge or discharge the BESS to 60% SOC. Compare the charge or discharge energy to the required energy to bring to start SOC based on the measured energy capacity from the RPT.
 - i. during charge, the charge energy = (Measured discharge energy capacity from RPT)*(60% SOC-BES SOC)/(SOCmax-SOCmin)/RTE from RPT test
 - ii. during discharge, the discharge energy = (Measured discharge energy capacity from RPT)*(BESS SOC -60% SOC)/(SOCmax-SOCmin)
2. Rest for 20 min
3. Apply the frequency regulation signal
4. Rest for 20 min
5. Bring battery back to initial 60% SOC

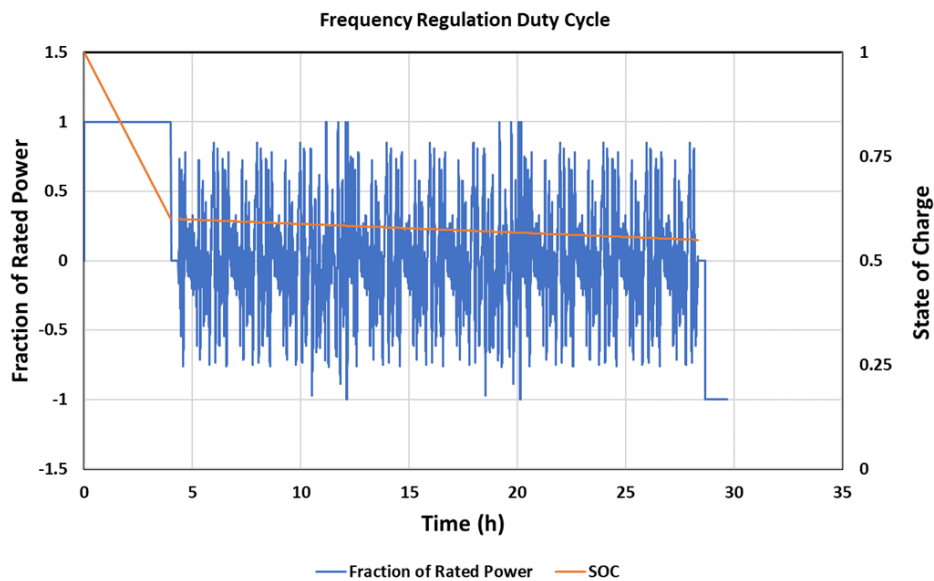

Figure 8. Protocol for frequency regulation.

6.6 Schedule for Standby Energy Loss

This test is done once a year: at the start of testing and every 12 months thereafter. Document RPT 070723.xlsx provides a row-by-row schedule for the Standby Energy Loss Rate protocol and that information is reproduced below. Figure 9 shows the power commands sent to the BESS as a function of time.

1. Bring the BESS to max SOC
2. Rest for 20 minutes

3. Discharge at rated power to minimum SOC and record the energy capacity as Wh_initial
4. Charge the ESS to SOC max
5. Rest ESS for 3 days with contactor connecting BESS to grid closed.
6. Record SOC. Discharge BESS at rated power to SOC min. Record the measured energy capacity Wh_1week
7. Rest 20 min
8. Charge BESS back to initial SOC and determine RTE (the RTE is not a critical metric here, the energy loss during standby is the important metric for this test. Record this charge energy as Wh_charge)

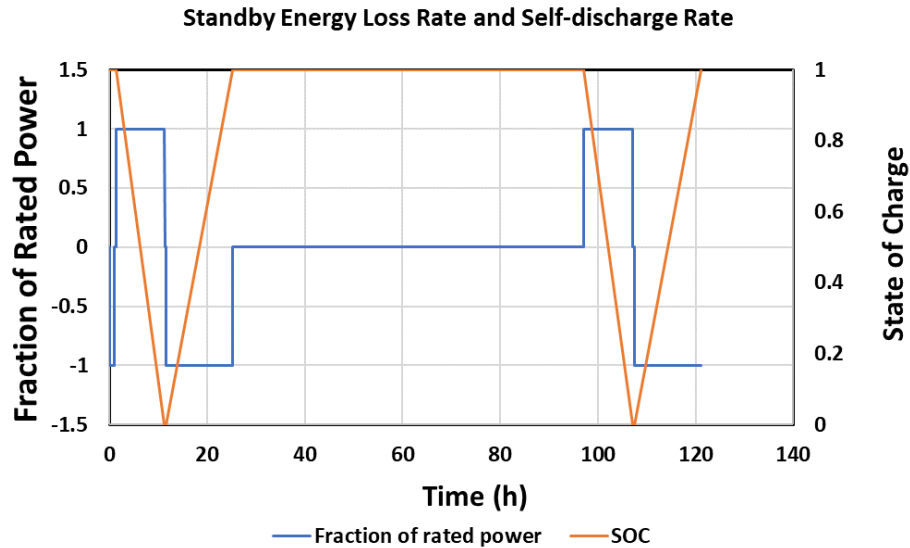

Figure 9. Protocol for standby energy loss rate and self-discharge rate.

6.7 Timeline for Reference Performance Tests

Figure 10 specifies when particular reference performance tests should be performed over the course of a twelve-month period.

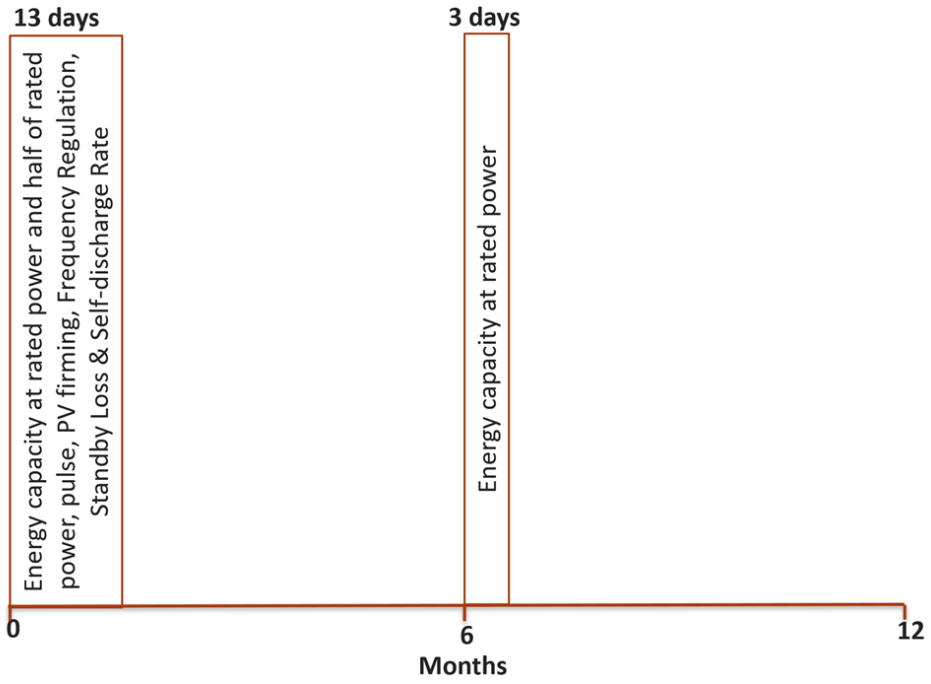

Figure 10. Monthly timeline for ROVI RPT requests.

7. Data Request Checklist

Table 11 summarizes the full list of information that the ROVI team is requesting from the project performer, as well as the method and timeline for that information transfer.

Table 11. Checklist of documents for project performer to share with ROVI team.

Description	Sharing Format	Timeline for Sharing
System Metadata	ROVI-provided System Metadata Excel sheet completed and uploaded to designated shared drive	Within two months of project start
System Physical Layout	Upload to designated shared drive	
Power Meter Layout		
Aux Load Meter Layout		
Protection Component Layout		
Vendor Data Sheets		<ol style="list-style-type: none"> 1. Final data points list and communications protocol agreed upon during work plan development 2. Pipeline for data collection completed prior to project commissioning 3. Streaming data collection is continuous during project execution
Streaming Data Points	ROVI team and project performer to agree upon communications protocols	
Event and Maintenance Data	ROVI-provided Event and Maintenance Data sheet completed by project performer	Within two business days of an event or a resolution