

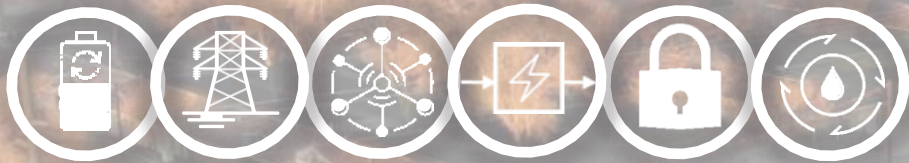

Power Electronics and Energy Conversion Systems Program at Sandia



Valerio De Angelis
Sandia National Laboratories
TRAC Program Peer Review
Oak Ridge National Laboratory
June 27-28, 2023



Sandia National Laboratories is a multimission laboratory managed and operated by National Technology and Engineering Solutions of Sandia, LLC, a wholly owned subsidiary of Honeywell International Inc., for the U.S. Department of Energy's National Nuclear Security Administration under contract DE-NA0003525.



Sandia National Laboratories is a multimission laboratory managed and operated by National Technology & Engineering Solutions of Sandia, LLC, a wholly owned subsidiary of Honeywell International Inc., for the U.S. Department of Energy's National Nuclear Security Administration under contract DE-NA0003525.

SAND2023-05624C

Power Electronics and Energy Conversion Systems

Improve grid operations through the development, adoption, and integration of new power electronics-based systems that are resilient, reliable, and cost-effective.

Three main research areas:

1. Develop and evaluate innovative devices and control strategies for grid applications
2. Understand and improve performance of advanced passive components and wide-bandgap semiconductors
3. Increase the standardization, performance, reliability, and safety of energy storage systems

Existing Labs

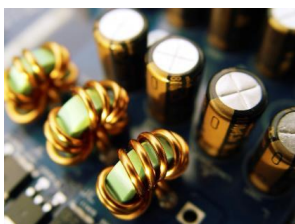

Mag Lab
Magnetics Fabrication and Characterization Laboratory
Improve the performance of high frequency magnetics to complement emerging WBG devices.



APEX
Advanced Power Electronic Conversion Systems
Supports the development of advanced power conversion topologies and intelligent control strategies.



DETL
Distributed Energy Technologies Laboratory
Designed to integrate emerging energy technologies into new and existing electricity infrastructure like solar and EV charging



ADL
Advanced Dielectric Laboratories
Develop High reliability, rad-hard capacitors – key elements of grid electronics



ESCAL
Energy Storage Controls and Analytics Laboratory
Dedicated to the development of next-generation energy storage control systems to increase battery performance and lifetime.



Navajo Nation Demonstration
Bring power to remote areas
Installed batteries developed with DOE Office of Electricity funding to power a remote community



WBG-SC Lab
Wide Bandgap Semiconductor Characterization Laboratory
Determine the reliability of emerging WBG devices. Correlate material physics to reliability of PCS.



ESTP
Energy Storage Test Pad
Provides long-term testing and validation for electrical energy storage systems.

Labs Under Construction (FY23-FY24)

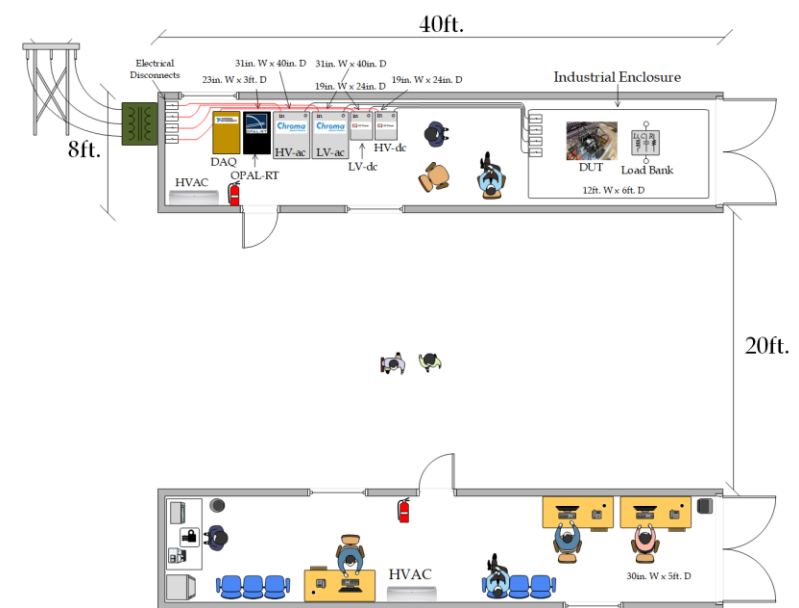
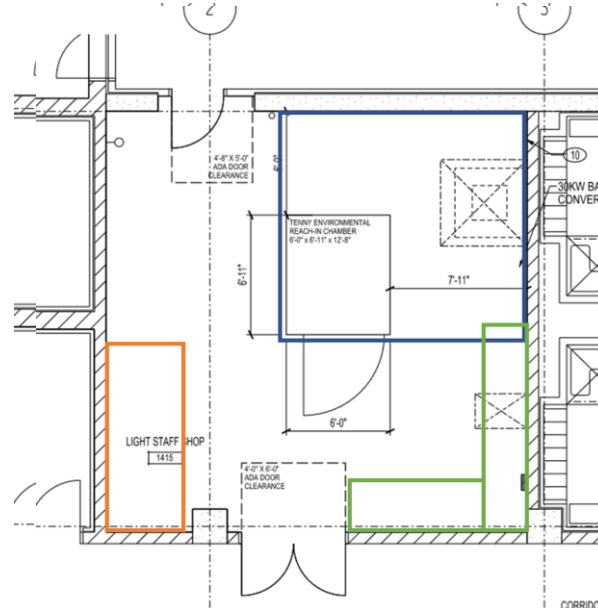
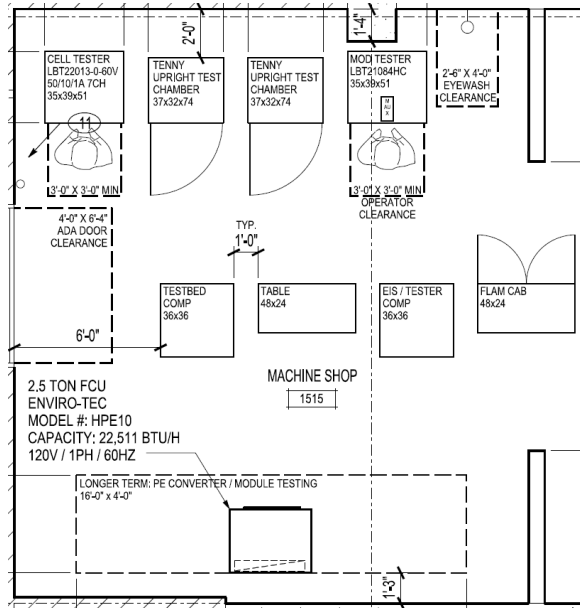

In-Situ Component Testing

Stressing of WBG Power Devices in Switch-Mode Converter



Custom-designed and built switch-mode power converter used to stress v-GaN diodes from AVOGY

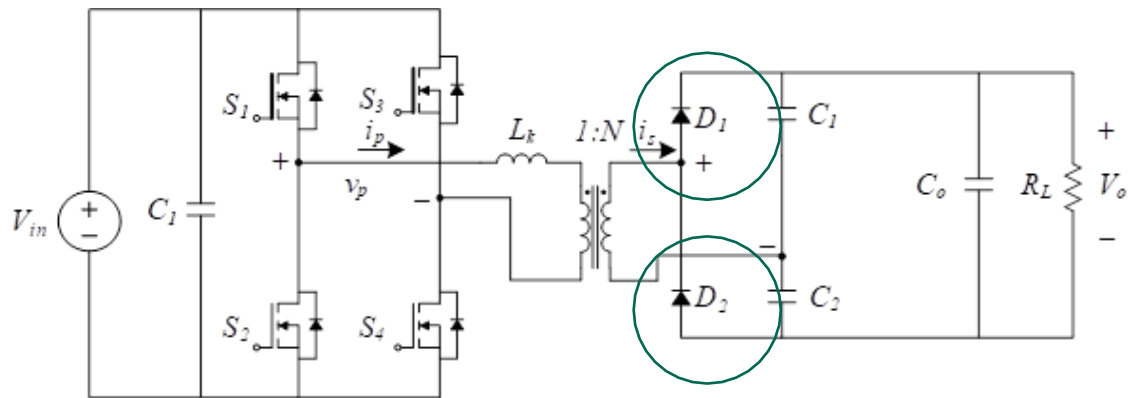

Test system full-bridge DC-DC converter topology

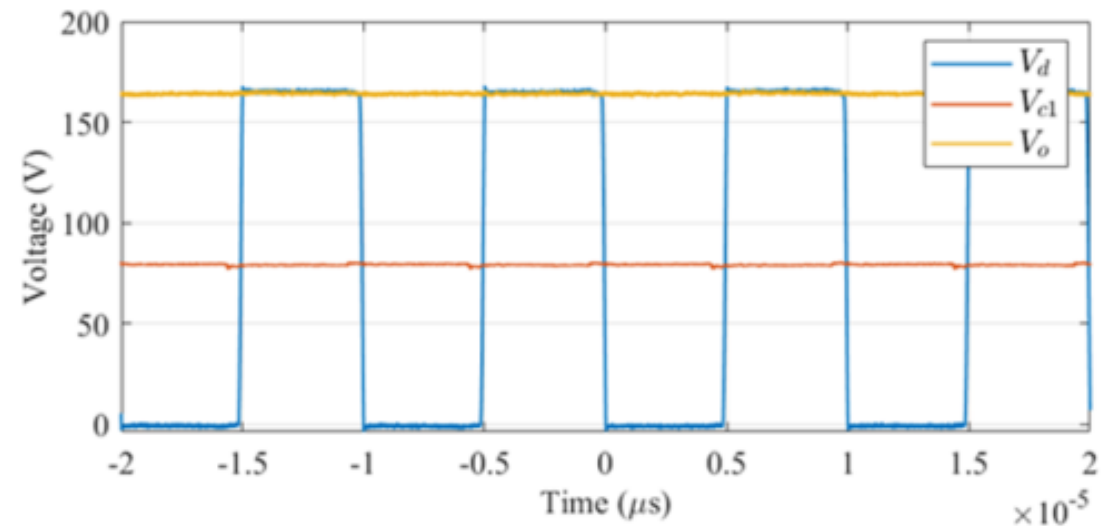
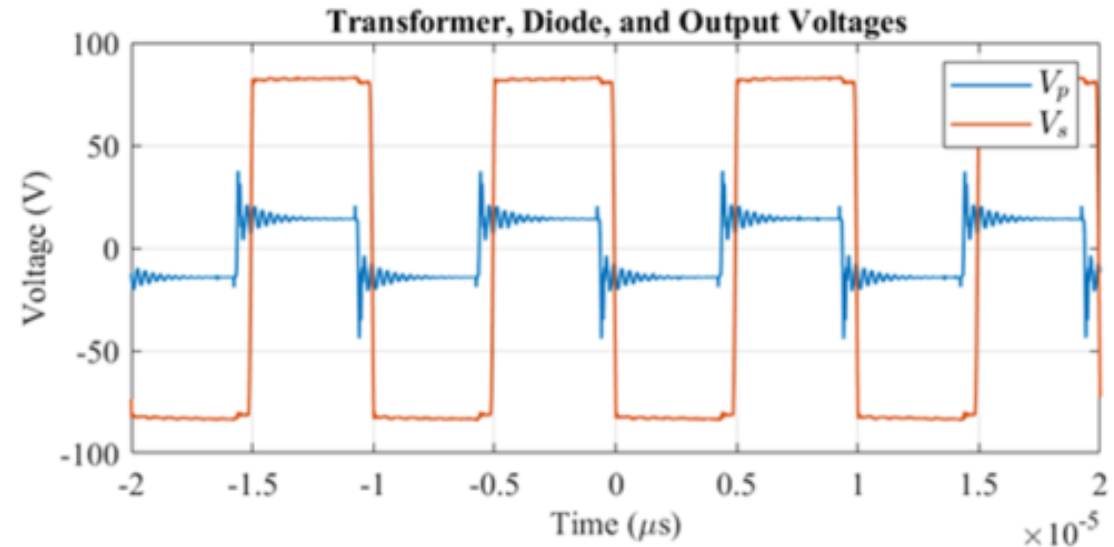

Full-bridge DC-DC converter experimental waveforms

Solid State Circuit Breaker (SSCB) Architecture (ARPA-E)

- Cascaded JFET HV switch topology
- Normally-On JFETs with low on-resistance and low auxiliary drive loss
- Normally-Off Photoconductive semi-conducting switch (PCSS) that triggers immediately after a fault to shunt current
- Capacitor for absorbing + dissipating energy from flyback current
- Control circuit powered from high-side voltage connection

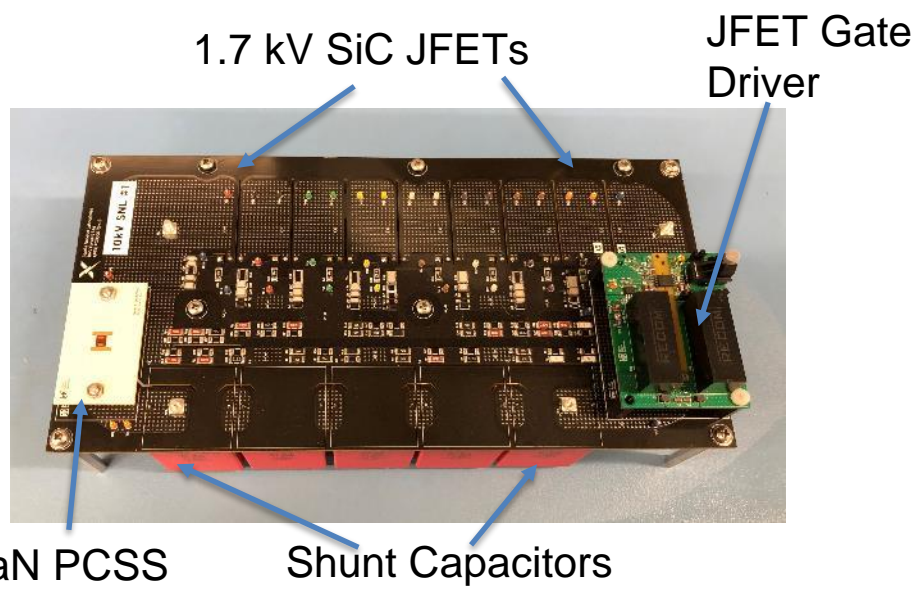

Cascaded JFET Circuit

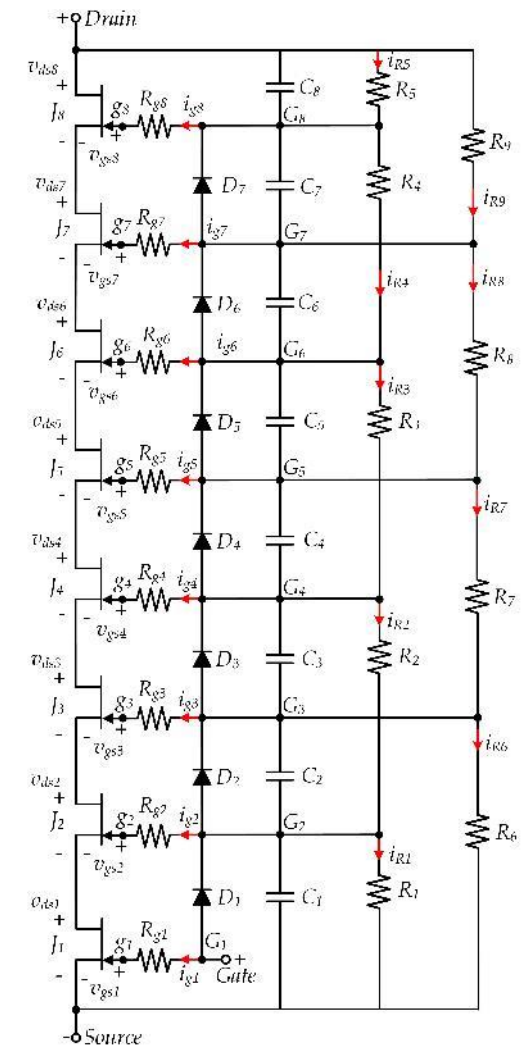

Target Performance

Parameter	Requirement
Blocking Voltage	10 kVDC
Rated Power	1 MW
Efficiency	99.97 %
Response Time	< 500 μ s
Life Time	30,000 cycles
Power Density	< 60 MW/m ³

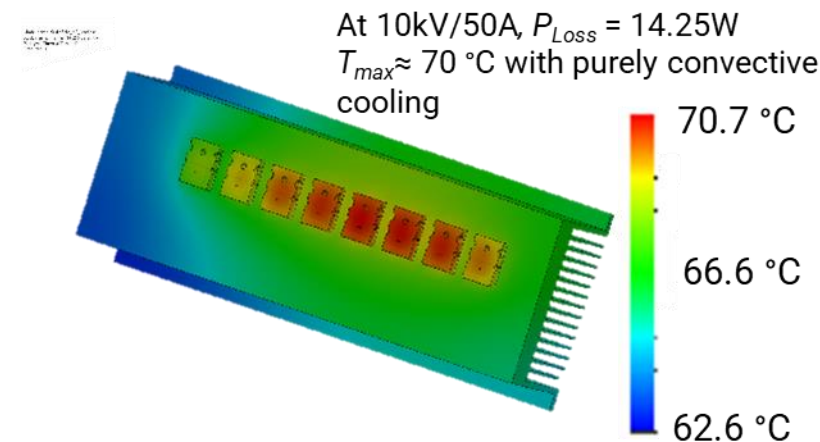

SiC JFET Forward Leg Results at 10kV/8A

Steady-state voltage balancing

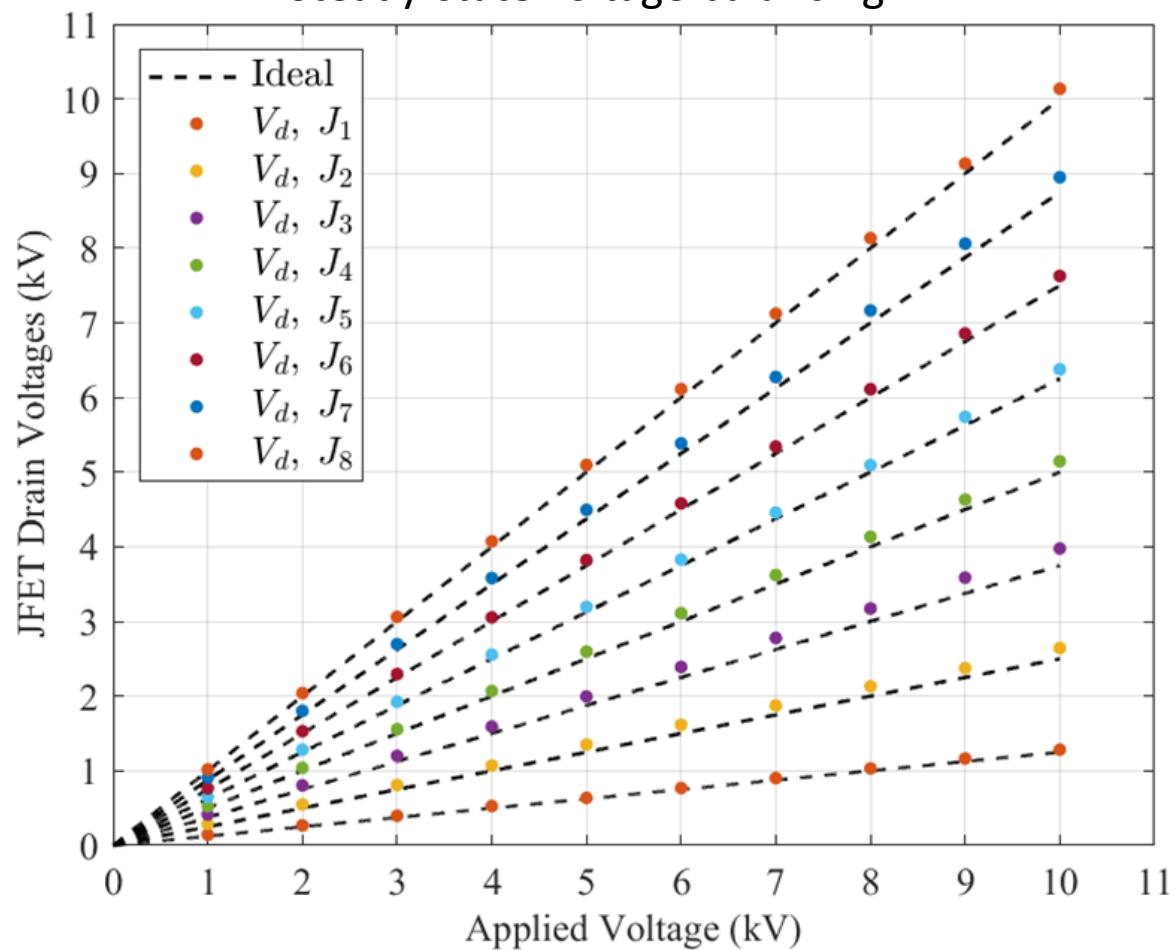

Turn-off transition

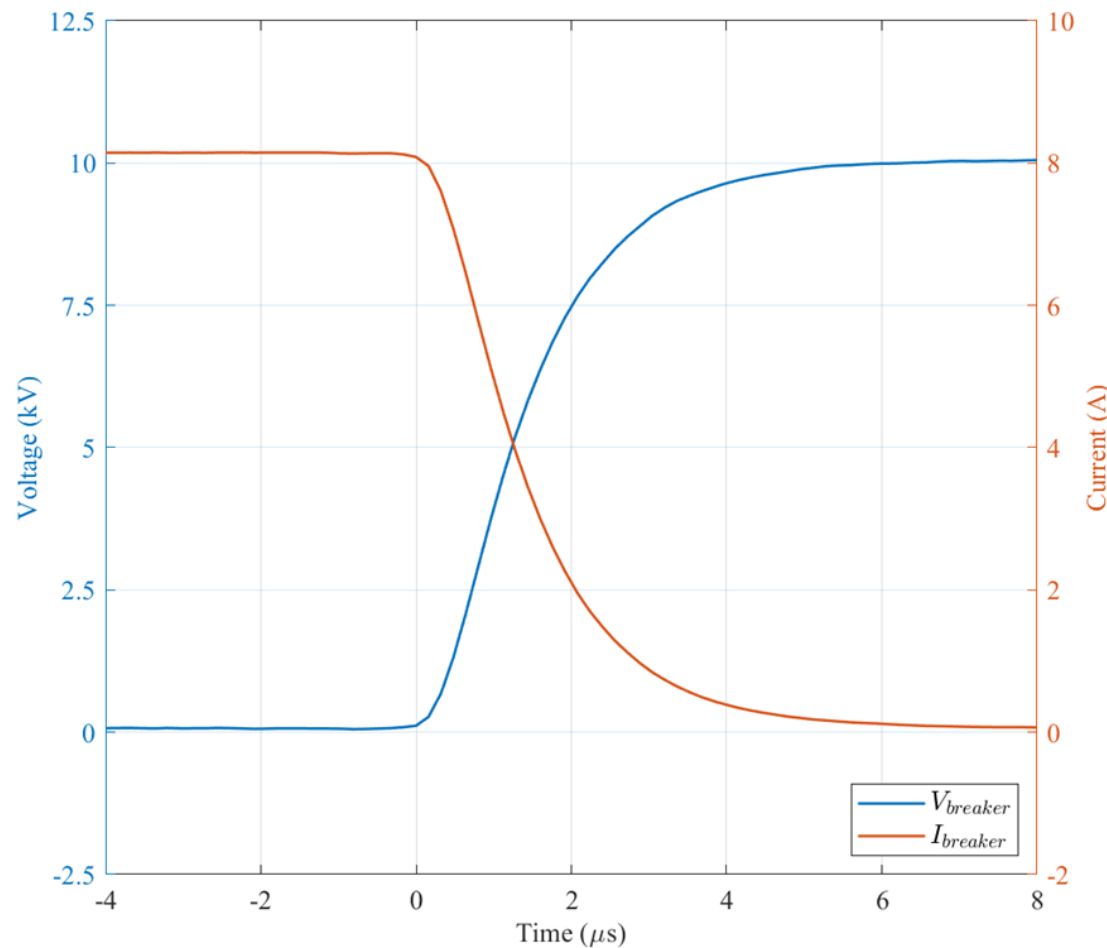

Solid State Transformer Project

- 3-year project funded by the Sandia Mission Campaign (LDRD)
- Select topology and run simulations
- Build control software
- Utilize and Improve SiC BiDFETs
- Improve magnetics and capacitors
- Build to 30kW 3p

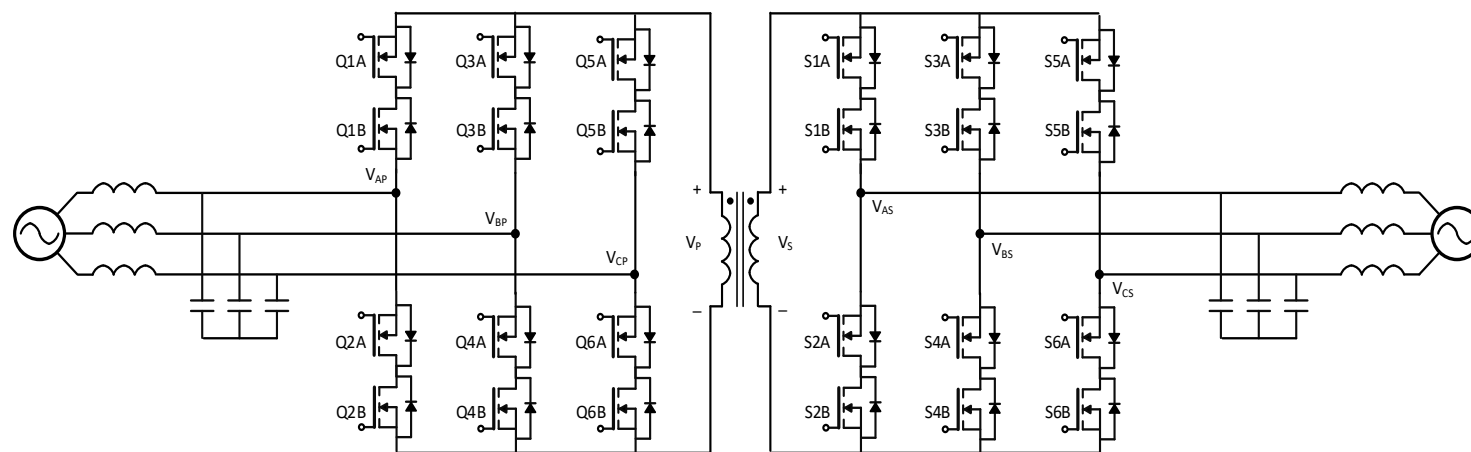
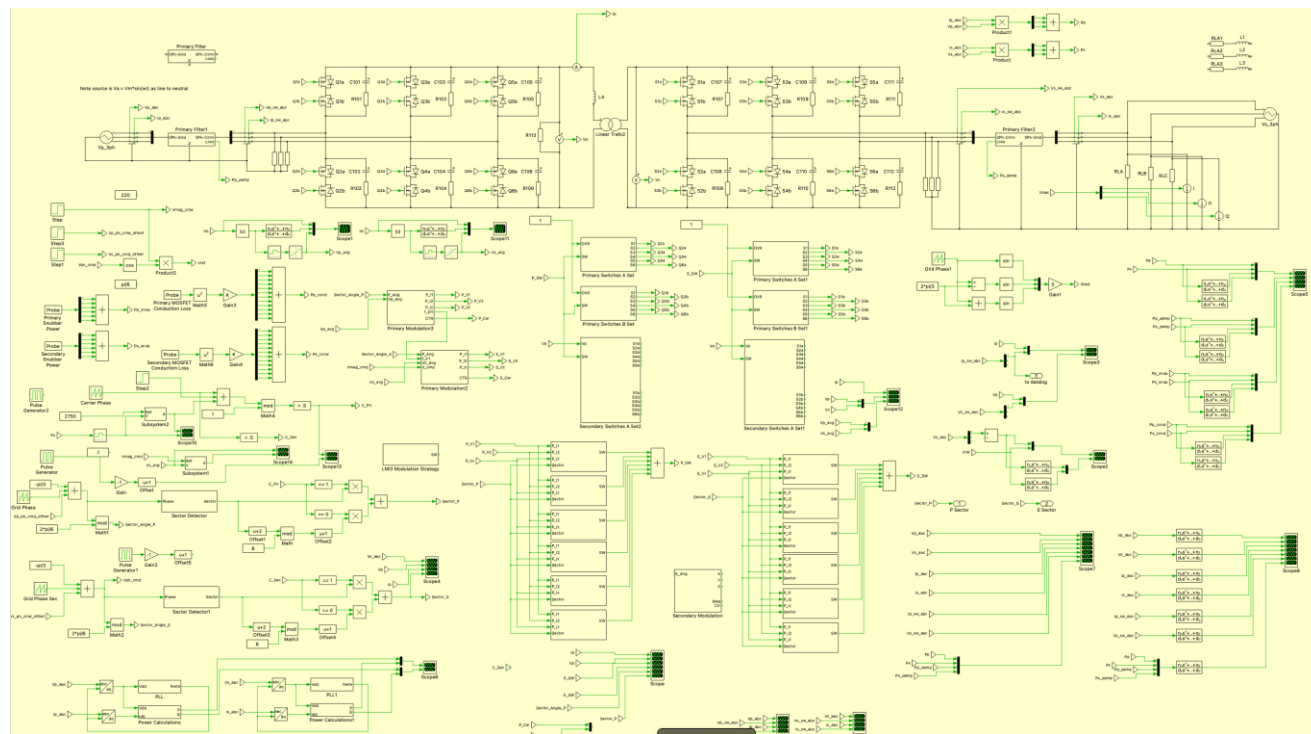
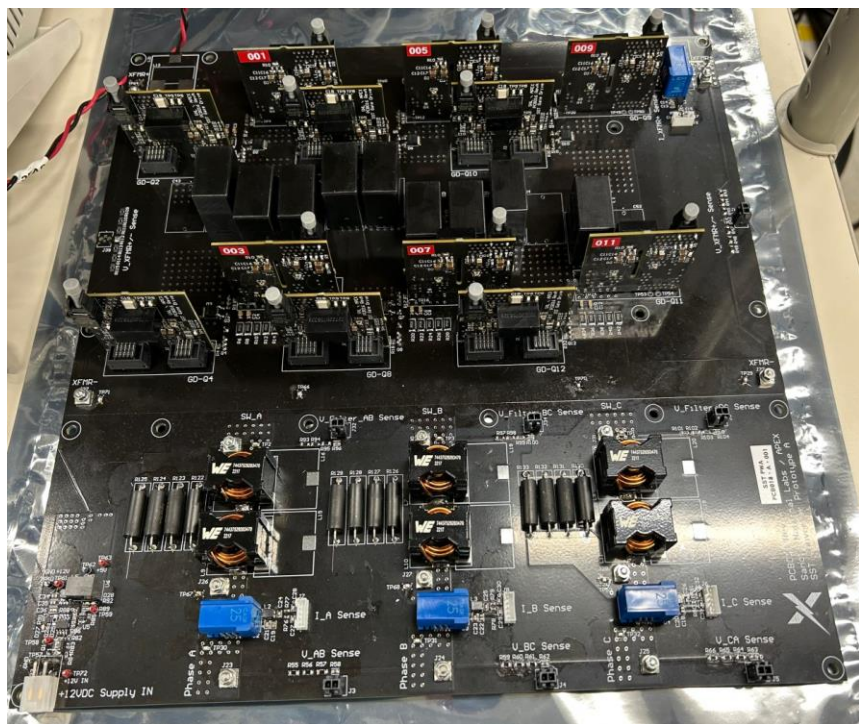

Solid state transformer project roadmap

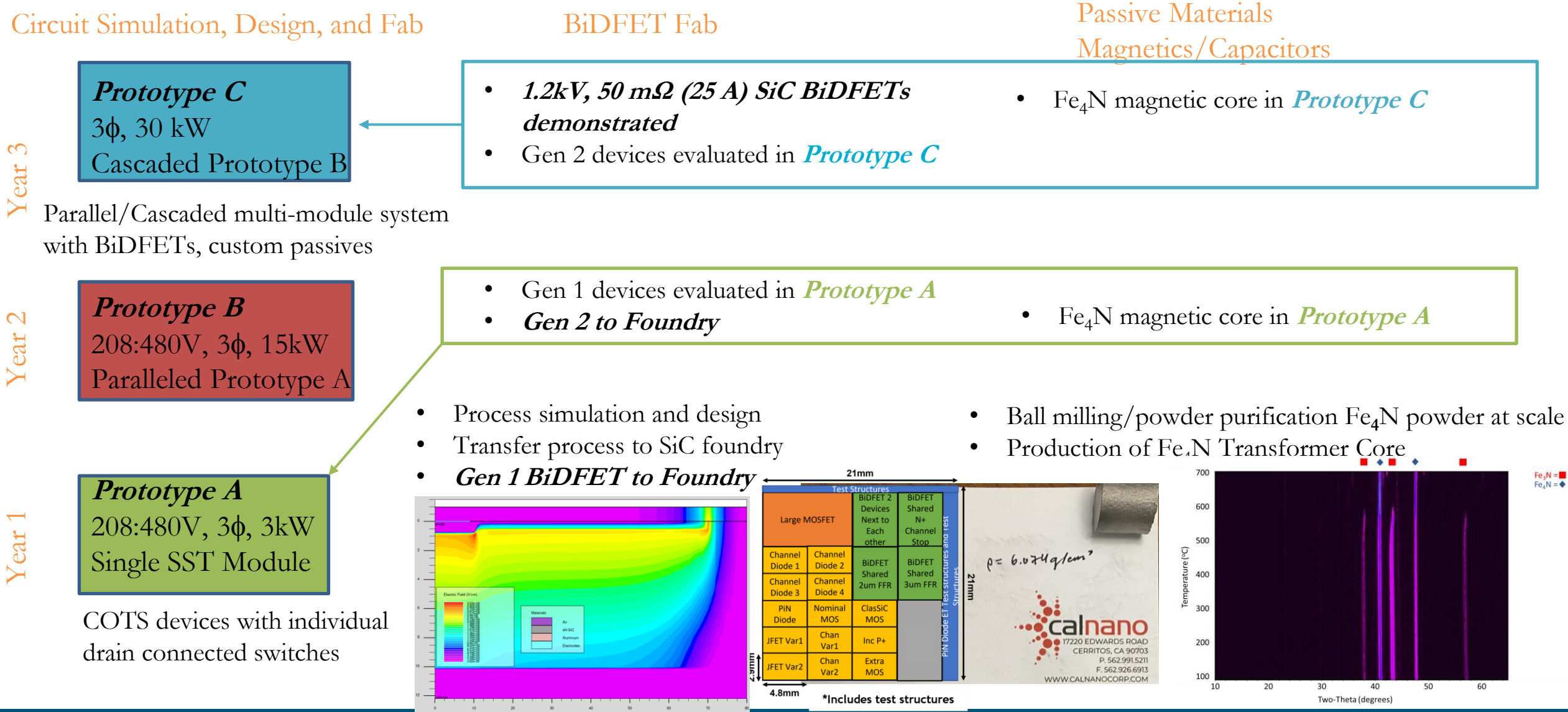

Power control

AC Voltage (Primary and Secondary)

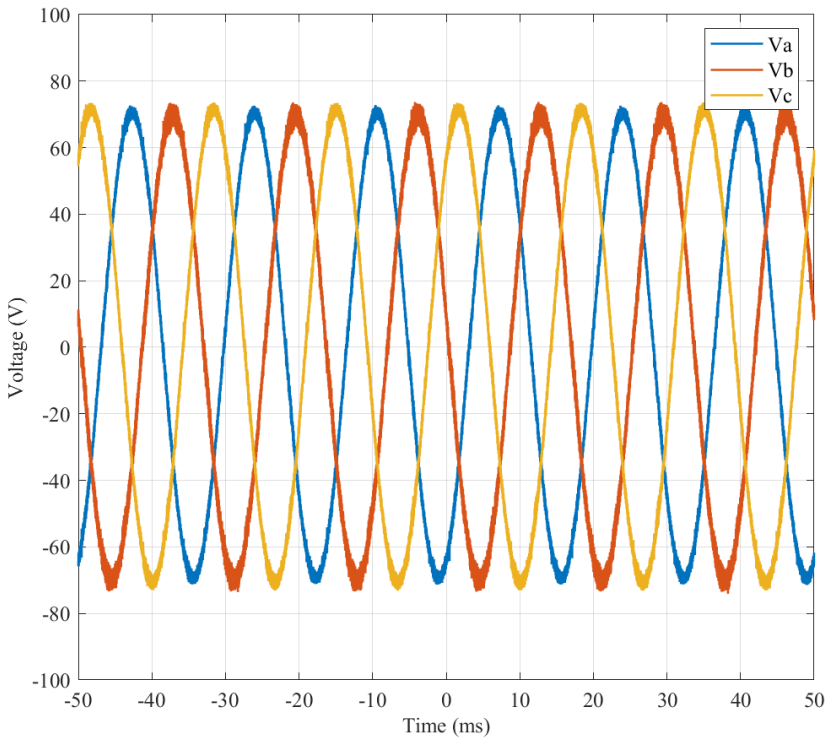

Transformer Voltages

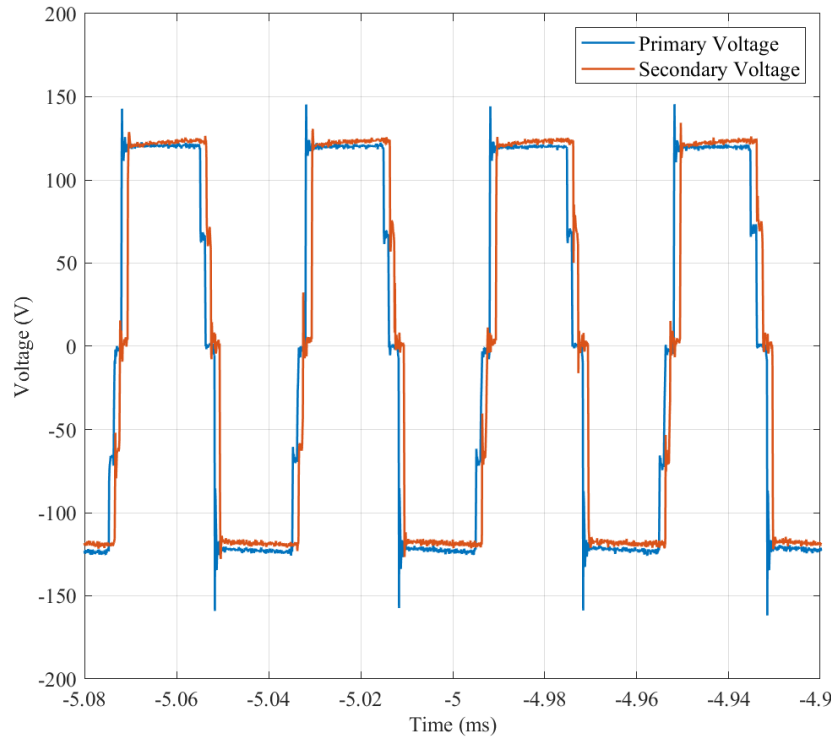

Transformer Currents

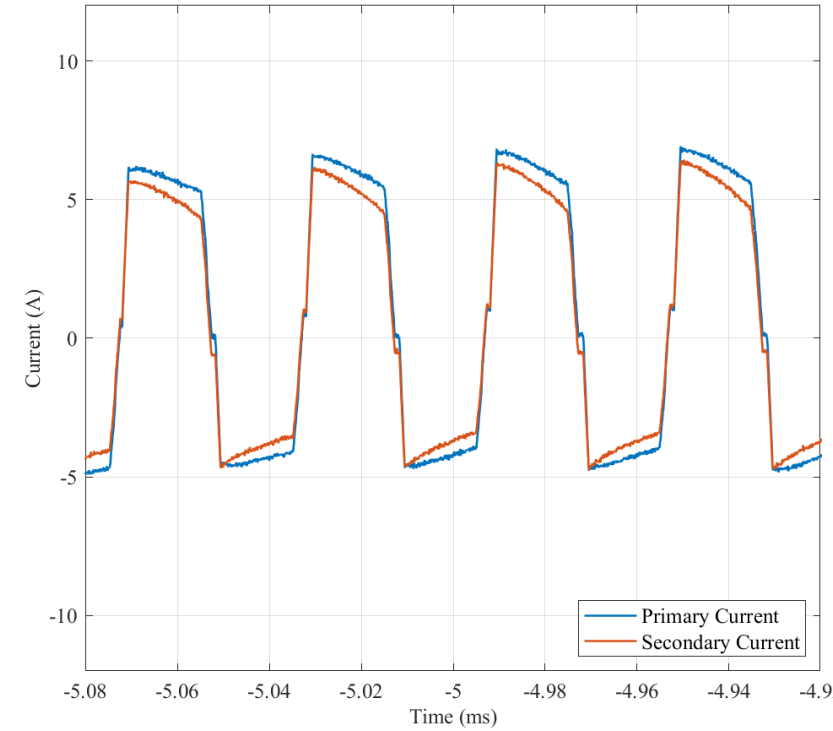

Multi-Level DC-DC Converters

Connect energy storage to Medium Voltage

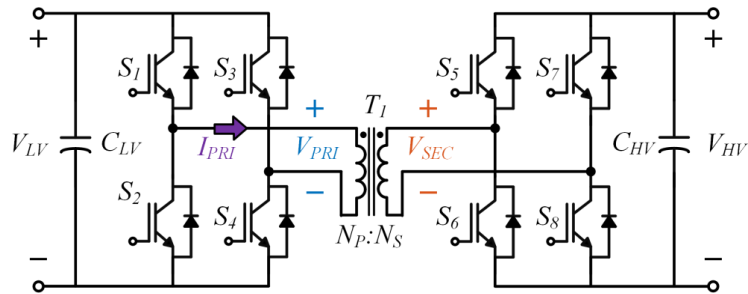

Converter Specifications	
Low-Side Voltage (V_{LV})	12V nom
High-Side Voltage (V_{HV})	72V nom
Switching Freq (f_{sw})	100 kHz
Rated Power (P)	$\pm 80W$
Turns Ratio ($N_P:N_S$)	5:30

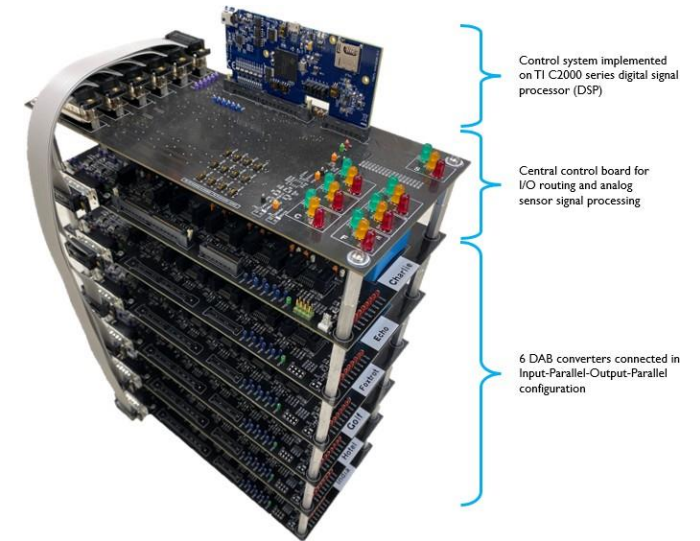

Six Cascaded DAB Converters with Controller

Control system implemented on TI C2000 series digital signal processor (DSP)

Central control board for I/O routing and analog sensor signal processing

6 DAB converters connected in Input-Parallel-Output-Parallel configuration

Hybrid Energy Storage System

- Batteries operate in different voltage ranges and their V-P curves change as they age
- Each controller be set to a different charging/discharging current or voltage, and can be disconnected at different voltage levels.
- Aging batteries can be replaced without turning the string off
- If one battery fails, all the other batteries can still be used (mix old and new batteries)
- Long Duration Energy Storage (LDES) pack can keep power batteries charged

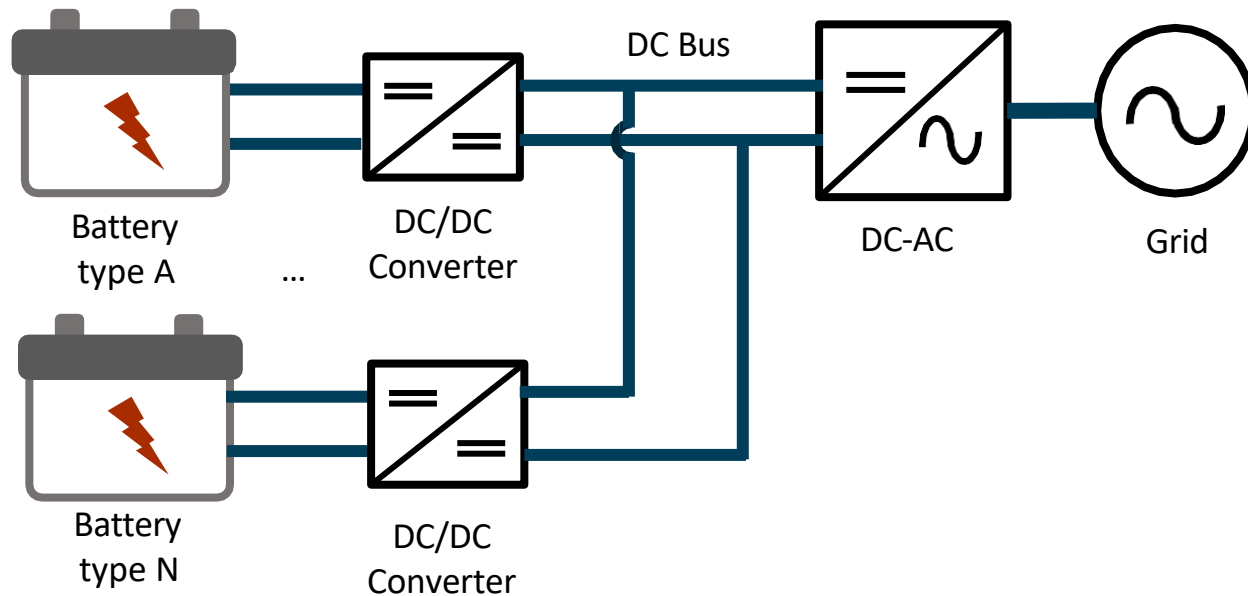

Modular Energy Storage Management System

Develop libraries for common hardware components

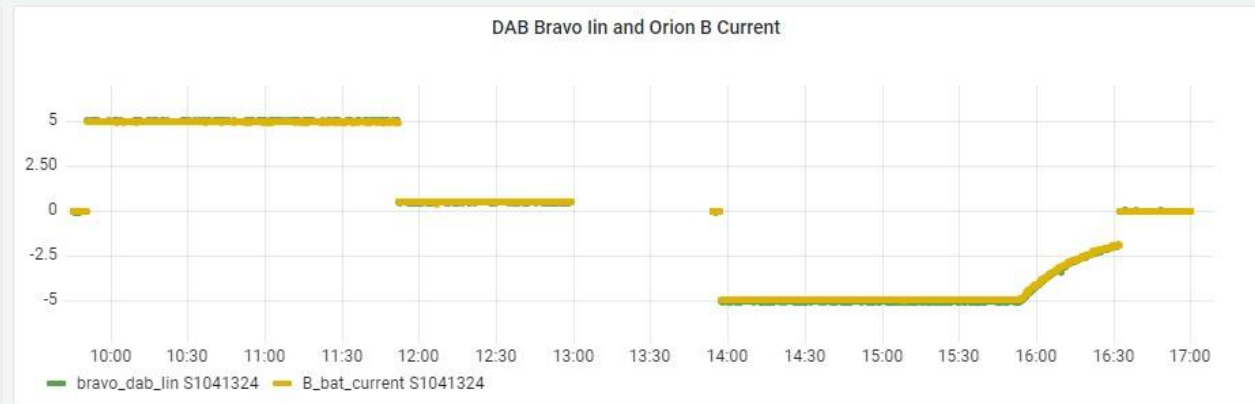
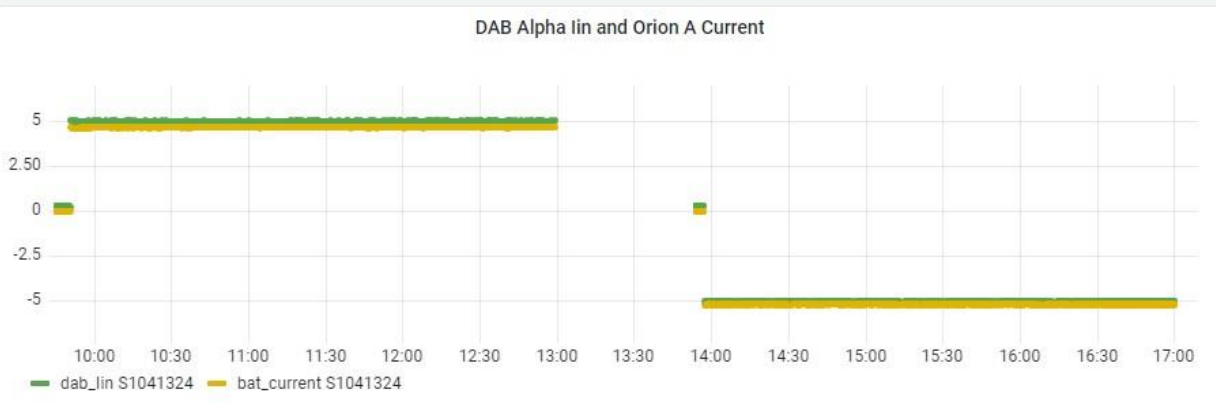
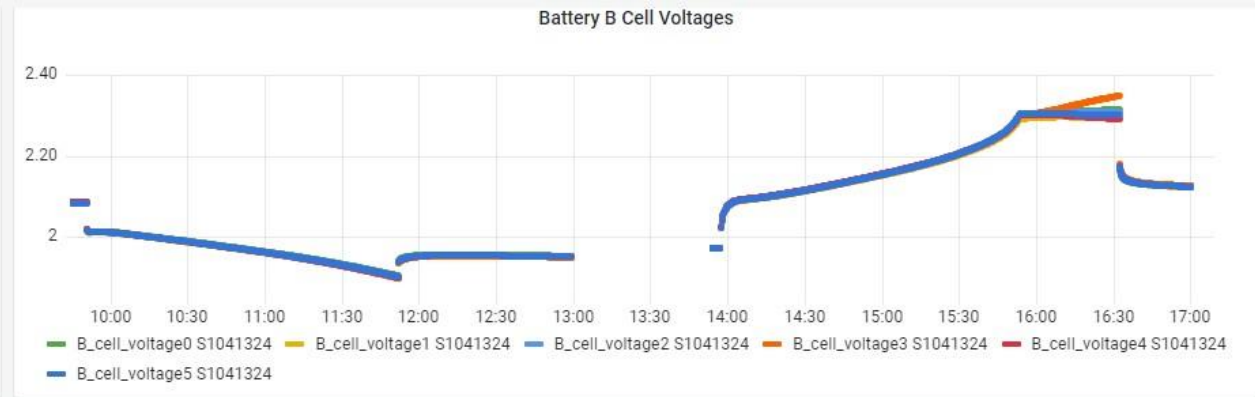
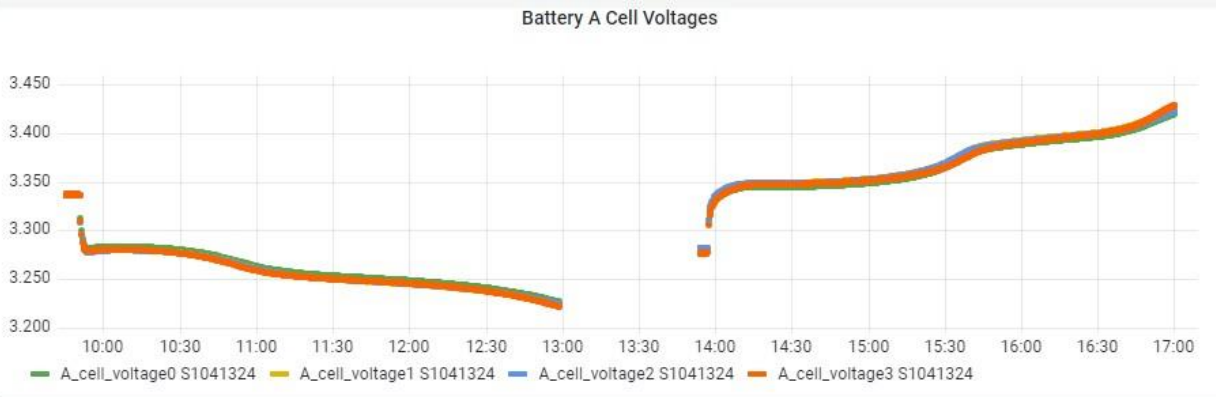
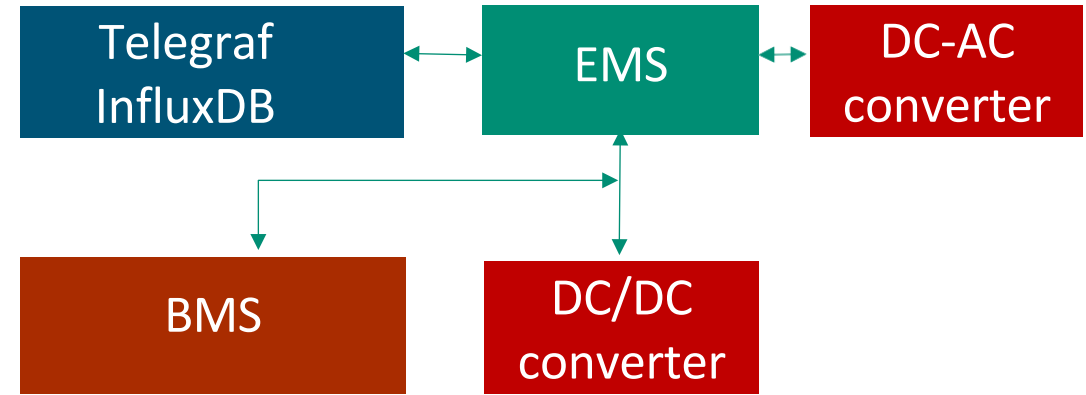

Summary

Develop components, sub-systems, and fully integrated systems for the electric grid:

1. Development and evaluation of components within Sandia and with partners:
 1. Magnetics
 2. Capacitors
 3. BiDFET
 4. PCSS
 5. Wide bandgap-based power modules

2. Development and integration of systems and subsystems:
 1. DC/DC converters
 2. Breakers
 3. Solid State Transformers
 4. Energy storage systems
 5. Integration of software API from embedded to cloud systems

Principal investigators: Jack Flicker, Jake Mueller, Luciano Garcia Rodriguez, Andrew Dow, Oindrilla Dutta, Bob Kaplar, Todd Monson

Upcoming event: Sandia Power Electronics Workshop (Albuquerque (NM), 8/2-8/3)

Funding: DOE OE Energy Storage (Dr. Gyuk), TRAC, ARPA-E, LDRD