

# ORNL Grid Integration Facilities

Brian Rowden

Group Leader Grid Systems Hardware

ORNL

# ORNL Facilities Summary

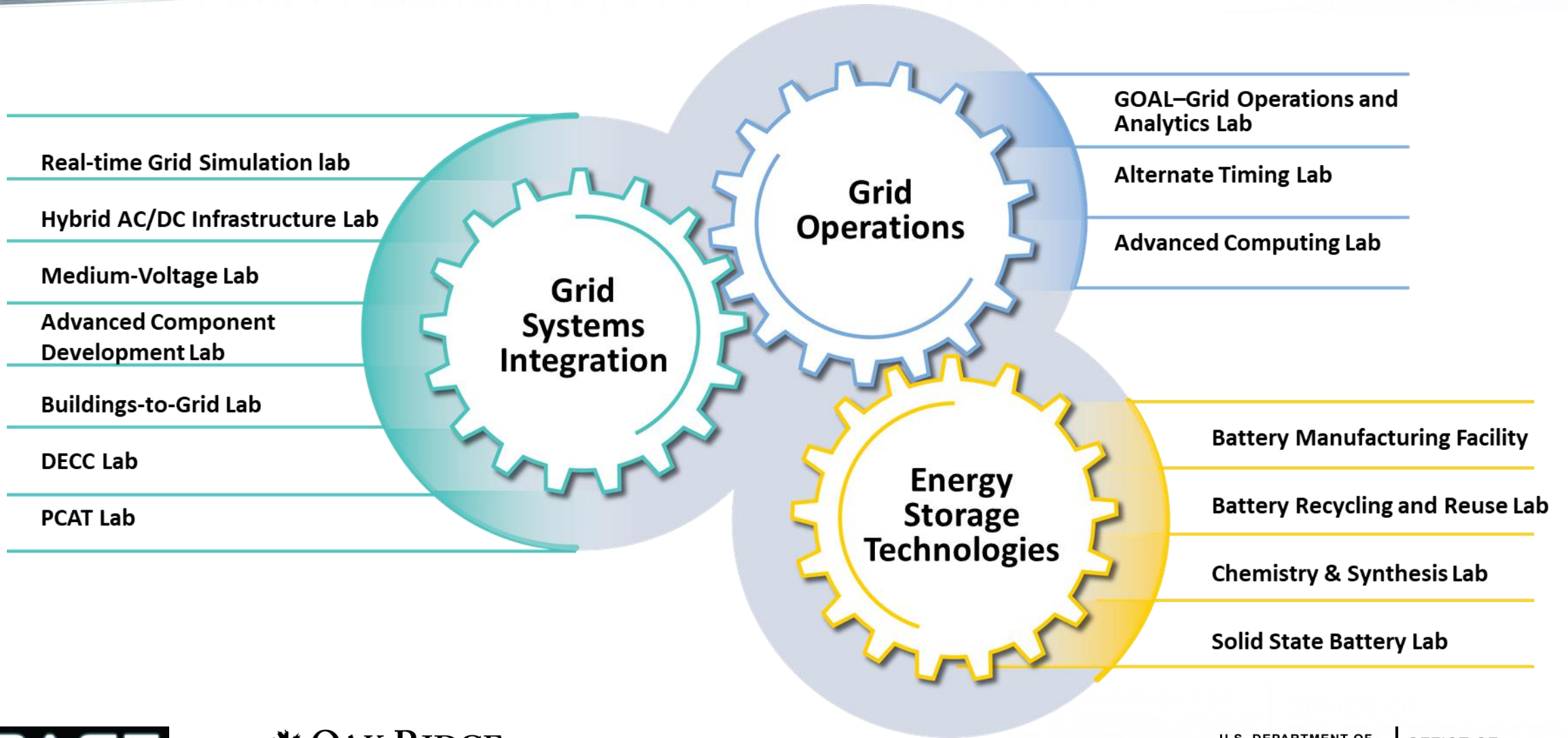



# Advanced Component Development – Magnetic Components

## ❑ Magnetics Design, Fabrication, and Testing

- ❑ Baseline design and assembly capabilities
- ❑ Work with both internal and external partnerships for construction and testing
- ❑ Pulse testing capability for evaluation
- ❑ Coordination of power testing at base converter levels and control strategy

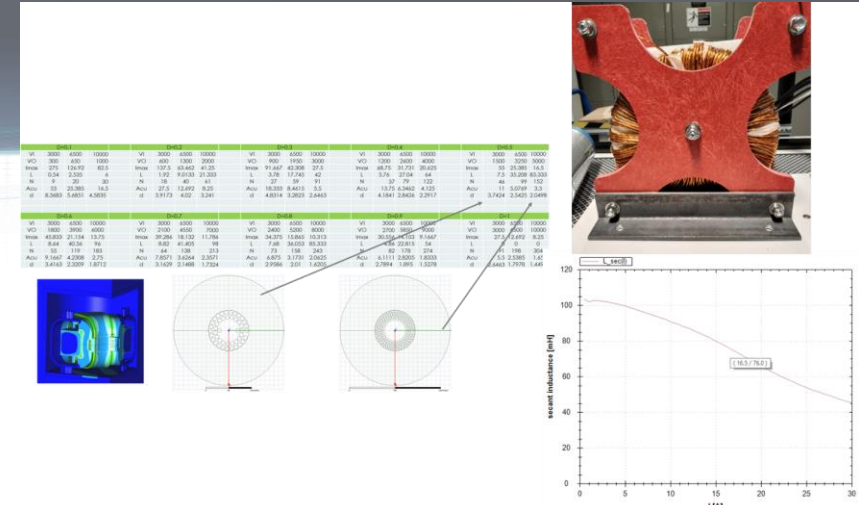
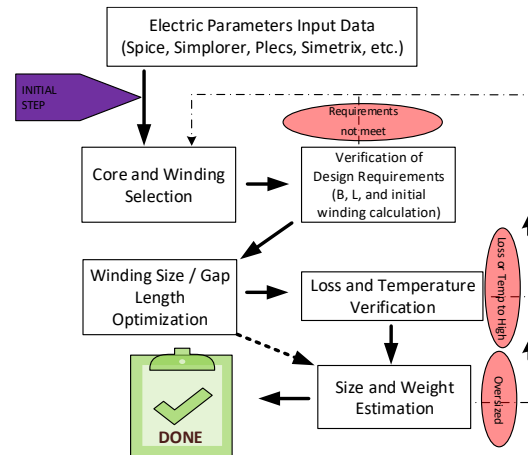

75 kVA Configuration Inverter Inductor Power Testing



Multigap smoothing inductor 1mH, 1 kHz, six gaps



175/350 kW DAB Transformer

Inductor number	Johnson Measurements	ORNL Measurements
1: J16736, 1mH	958.1 uH	904.1 uH @ 86 A
2: J16737, 500 uH	534.8 uH	510 uH @ 77 A
3: J16737, 500 uH	542.2 uH	512 uH @ 97 A
4: J16736, 1mH	967.7 uH	1055.9 uH @ 100 A

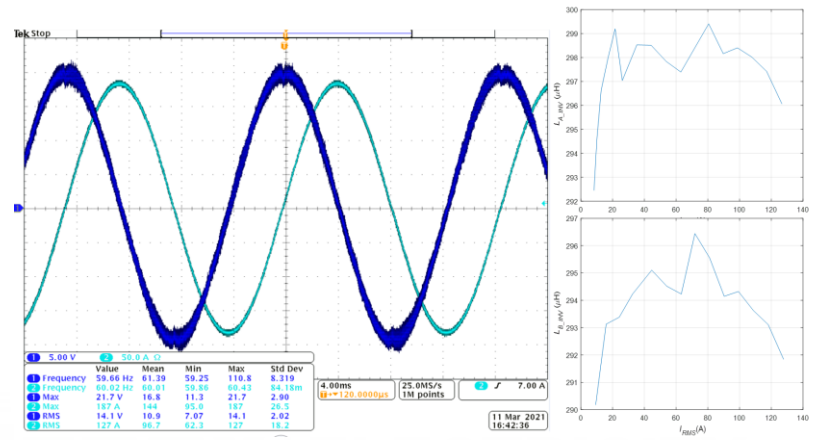
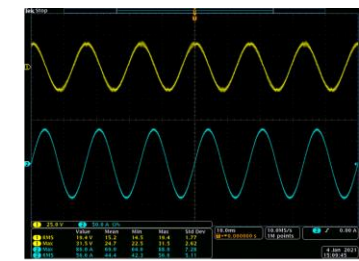
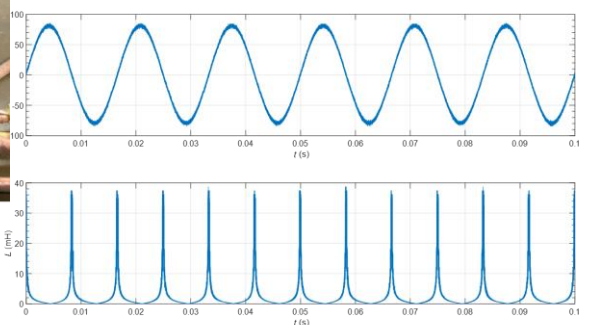

# Subsystem Packaging and Testing

## Power Electronics Assembly

- ❑ Pilot level assembly for component and subsystem integration for inverter and converter prototypes
- ❑ Component and sub-system level testing and configuration
- ❑ Magnetics development and pulse testing
- ❑ Evaluate of board level metrics for drivers, controllers, or sensors
- ❑ Automated dispensing, coating, and spraying capabilities for board rework, cleaning, epoxy, or conformal coating

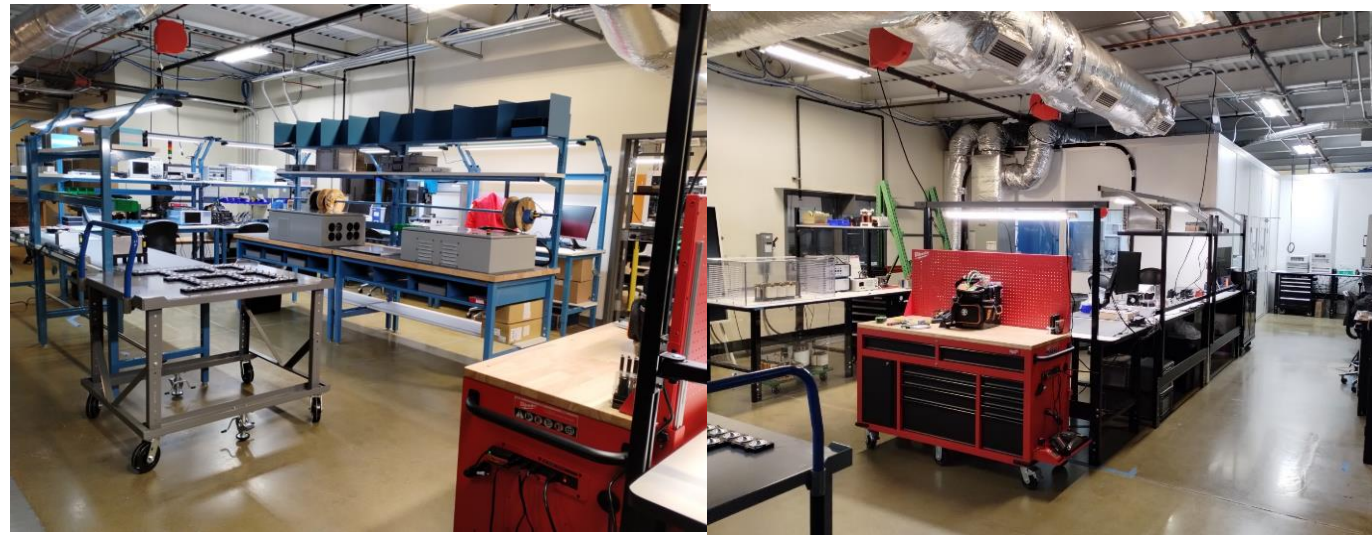
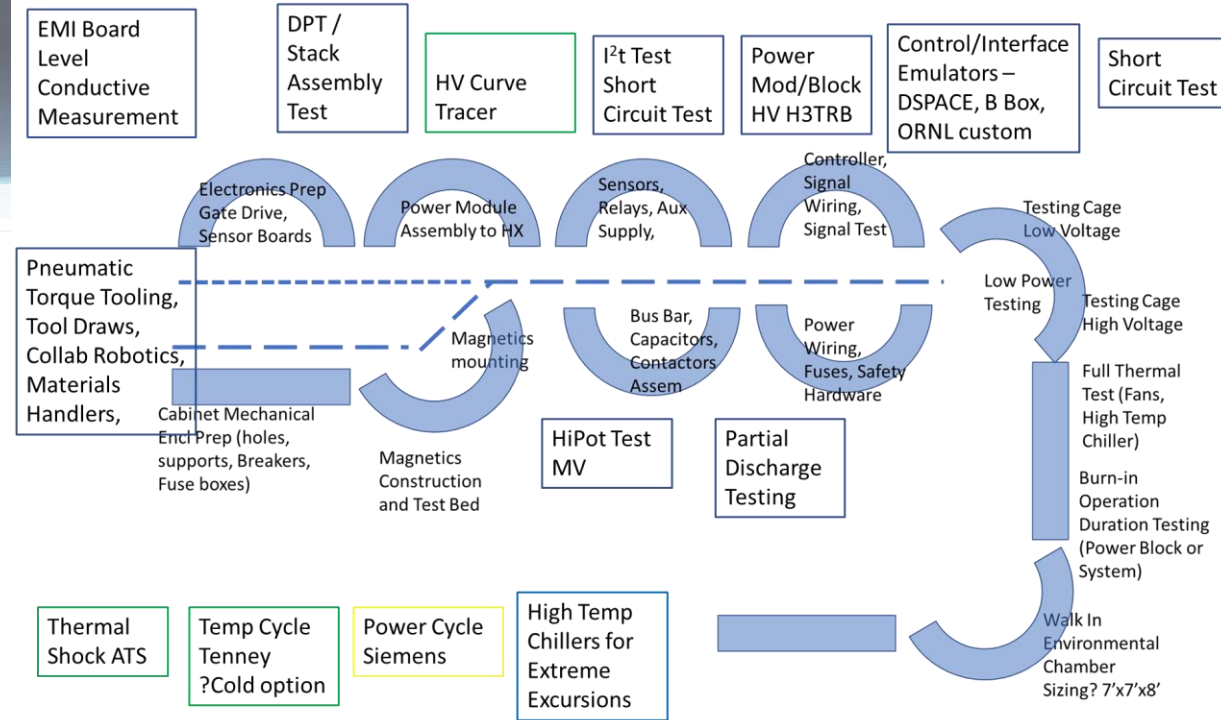
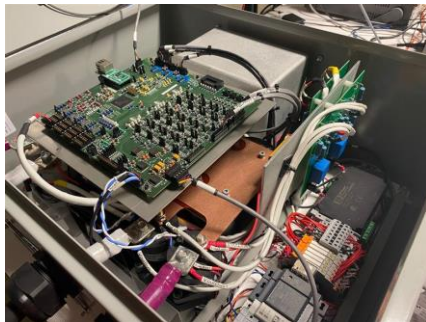

# Hybrid AC-DC Infrastructure Lab

## Technology resources

- ❑ (2) 480V 1200A 3-phase busways
- ❑ 1500V 2400A dc busway
- ❑ 6 interconnected test stations
- ❑ Remote controlled interfaces for each bus at each test station
- ❑ Each test station can operate with 2 source and 2 load emulators used independently or coupled
- ❑ Remotely reconfigurable trip settings, interconnect measurements, and isolation.

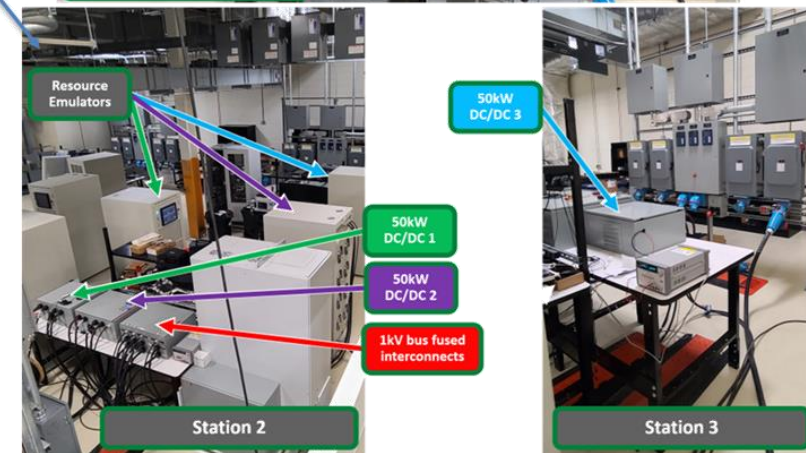
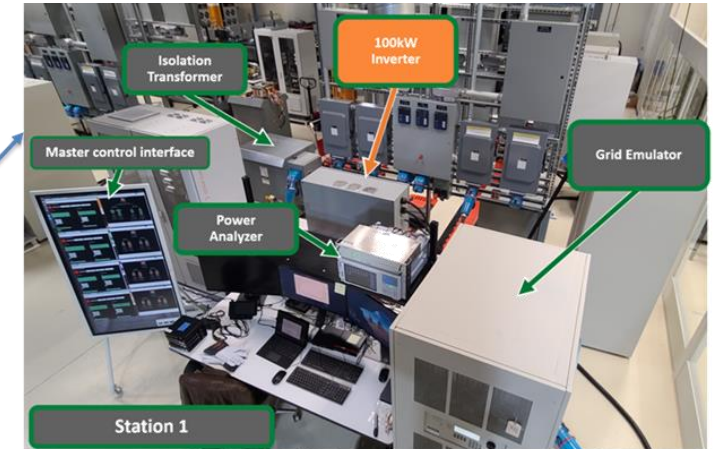
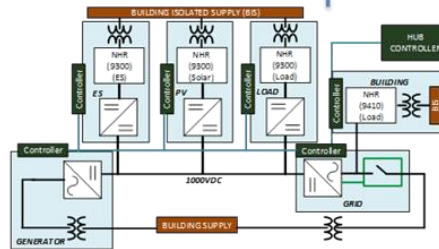
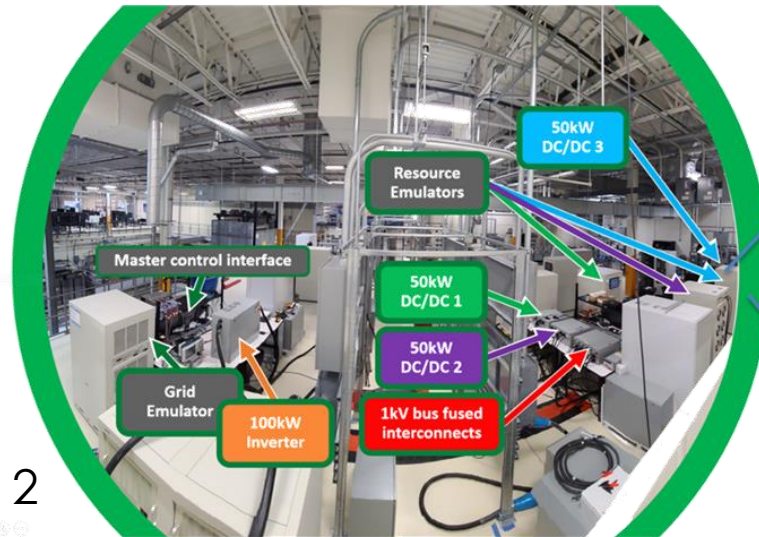

# Real-time Grid Simulation Lab and CODAS Platform

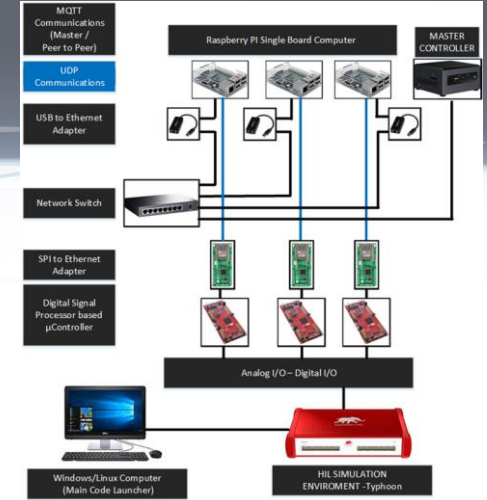

**Control and Optimization using Distributed Agent-based System (CODAS)**  
 Developed to support power electronic systems integration for both simulation and hardware projects

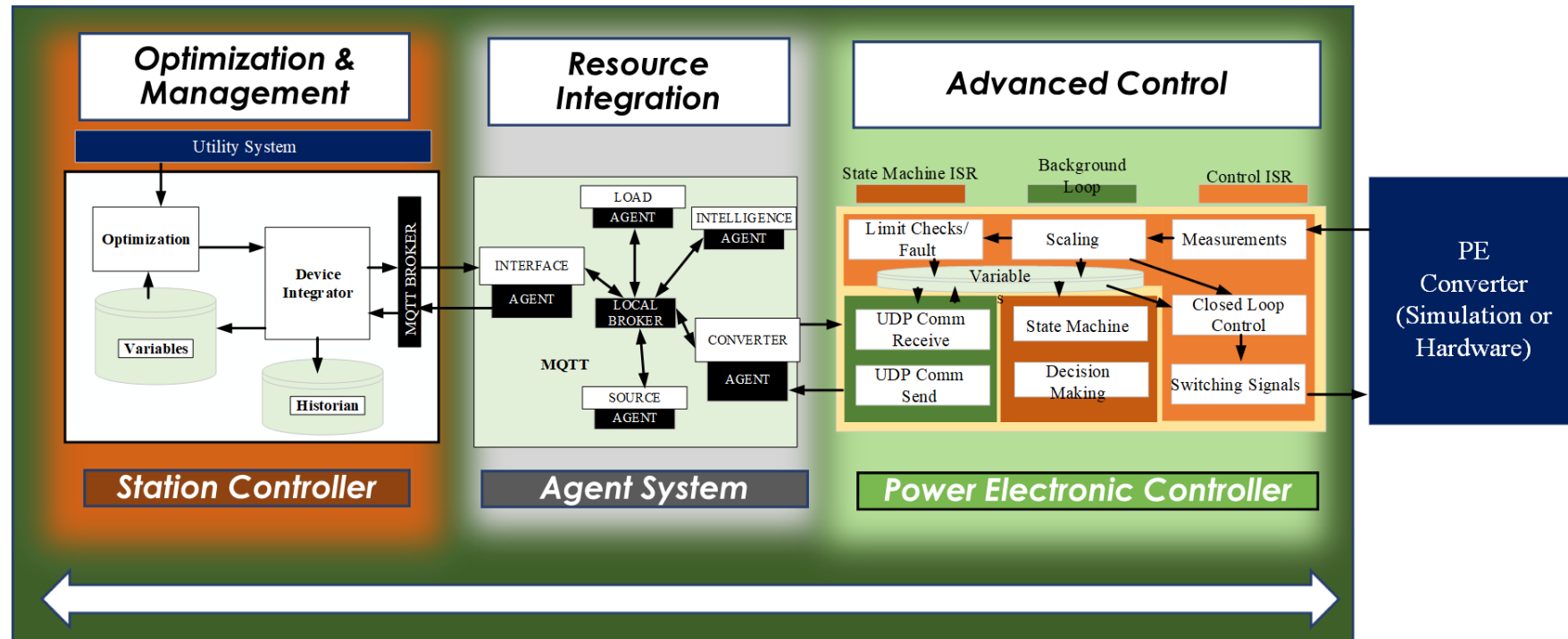

# Medium Voltage Lab

## Medium Voltage Test Lab

- 5 kV, DC 40 A isolated controllable power supply
- 2 kV, 400 A DC test bed for testing DC/DC converters in a loop
- 13 kV/1MW isolated transformer with multiple secondary taps (2.4-13.8 kV)
- Pulse test characterization, hipot, and partial discharge testing to 10kV
- 2 kV/50 kW load bank

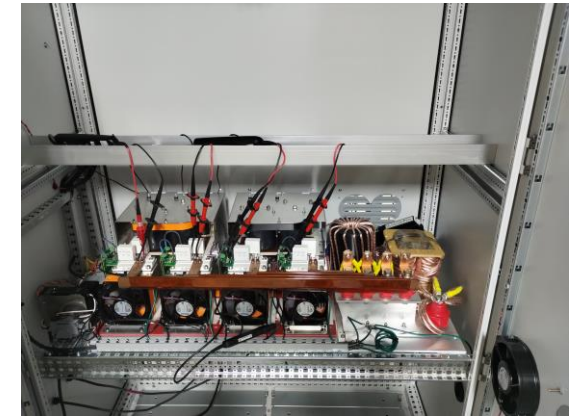
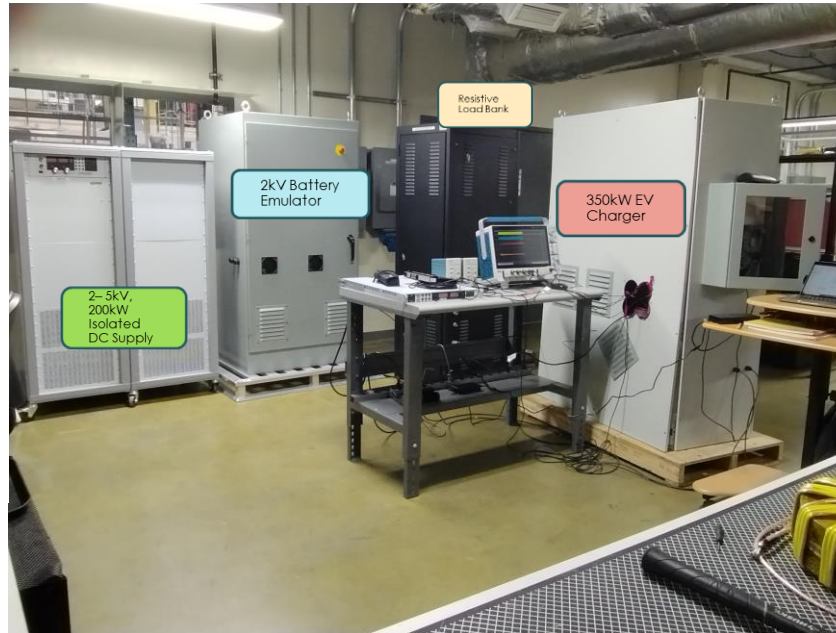

# Facility Integration Process

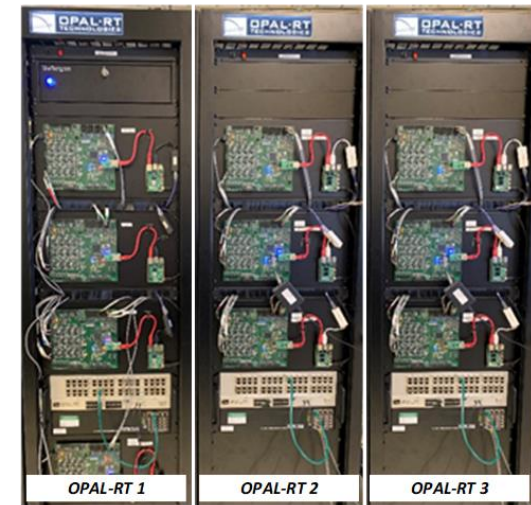
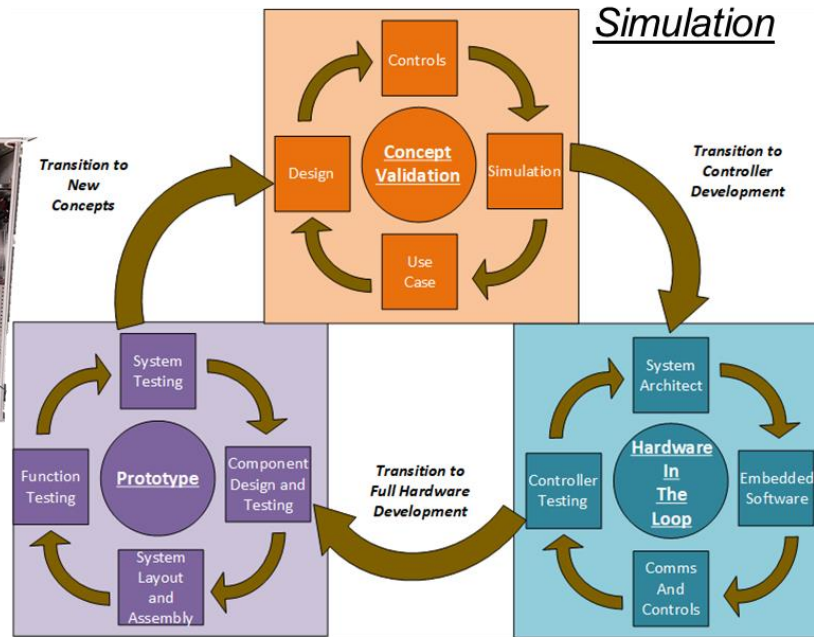
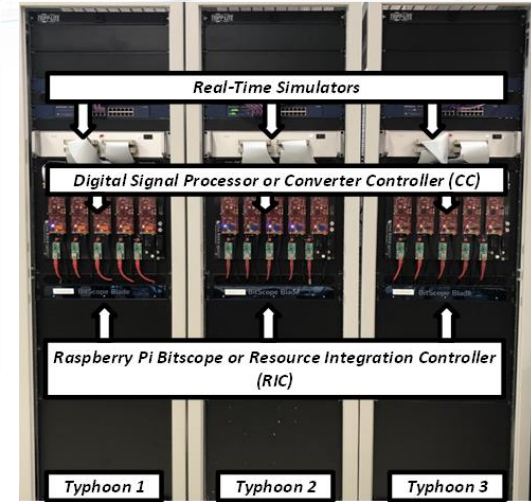
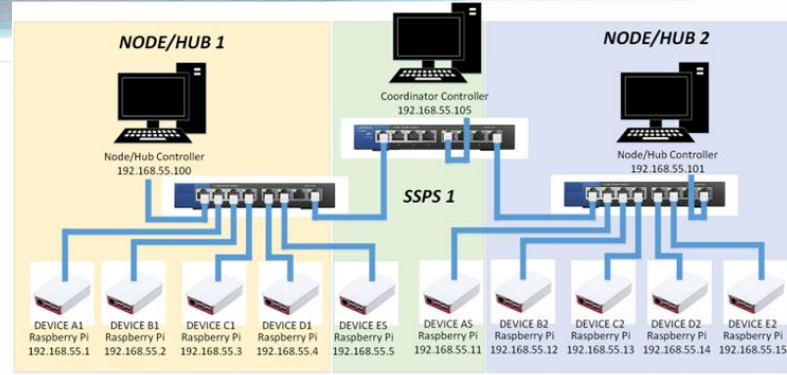
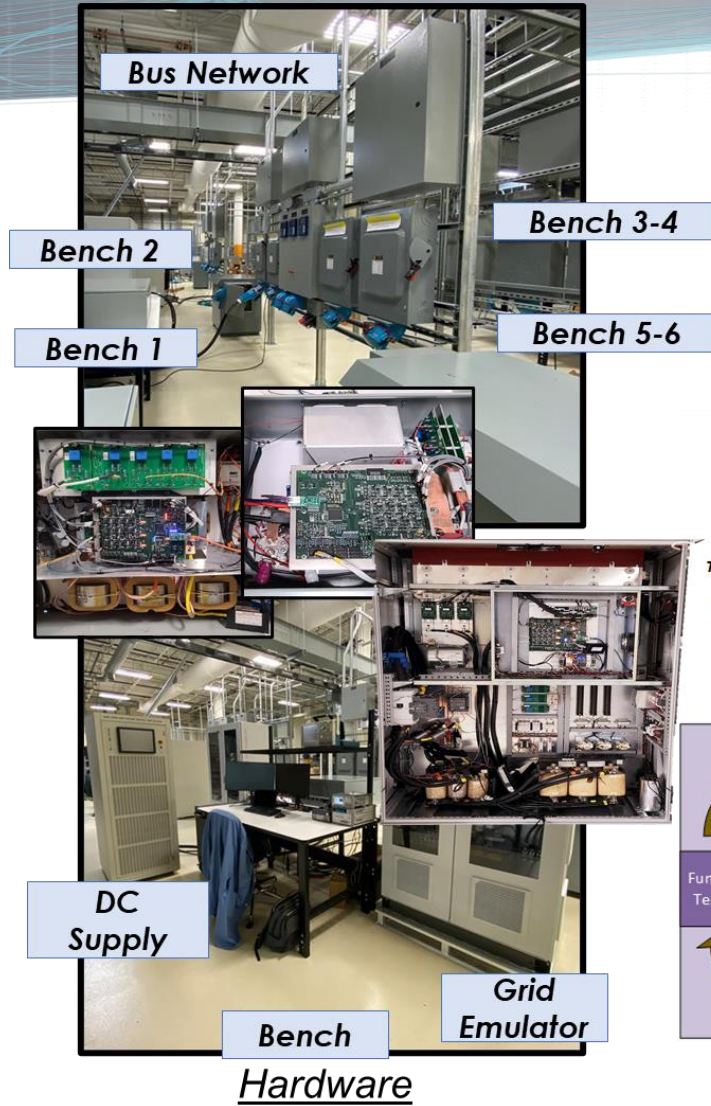

Hardware in the loop

M. Starke et al., "A Remote Development Process and Platform for Power Electronic Systems," 2021 IEEE Energy Conversion Congress and Exposition (ECCE), 2021, pp. 3182-3189.

# Distributed Energy Communications and Controls (DECC) Laboratory

- ❑ Transition from emulated test conditions to physical resources and real use conditions
- ❑ Couple ORNL, Industrial, and Academic power electronics solutions for testing and interaction with several different sources (PV, ESS, R/L loads, etc.)
- ❑ Evaluate bidirectional power flow and optimization with real source/load use case conditions
- ❑ Test bed for Anomaly Detection
  - ❑ Indoor and outdoor testing
  - ❑ Evaluation and demonstration of grid

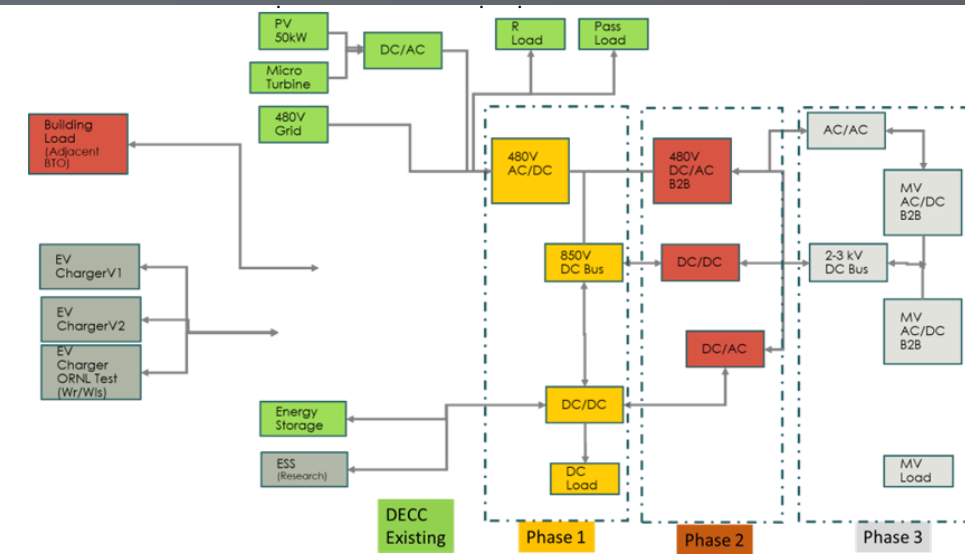
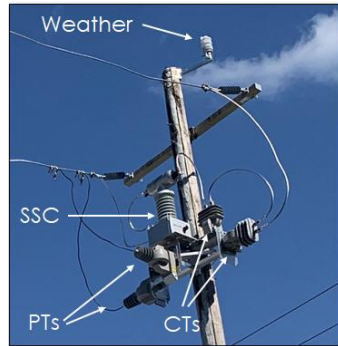

Figure 1. Conceptual configuration of use case demonstration test facility within the DECC lab

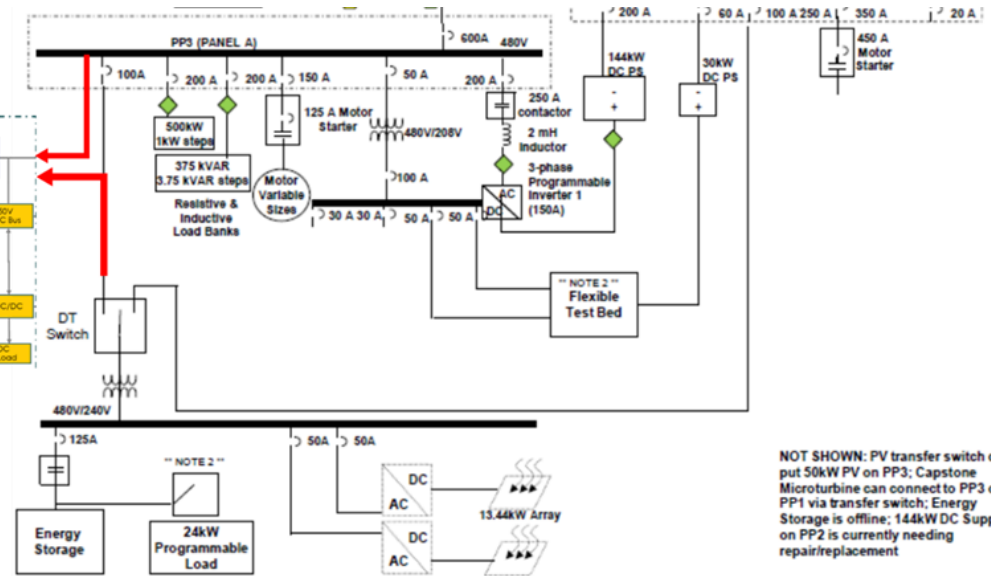
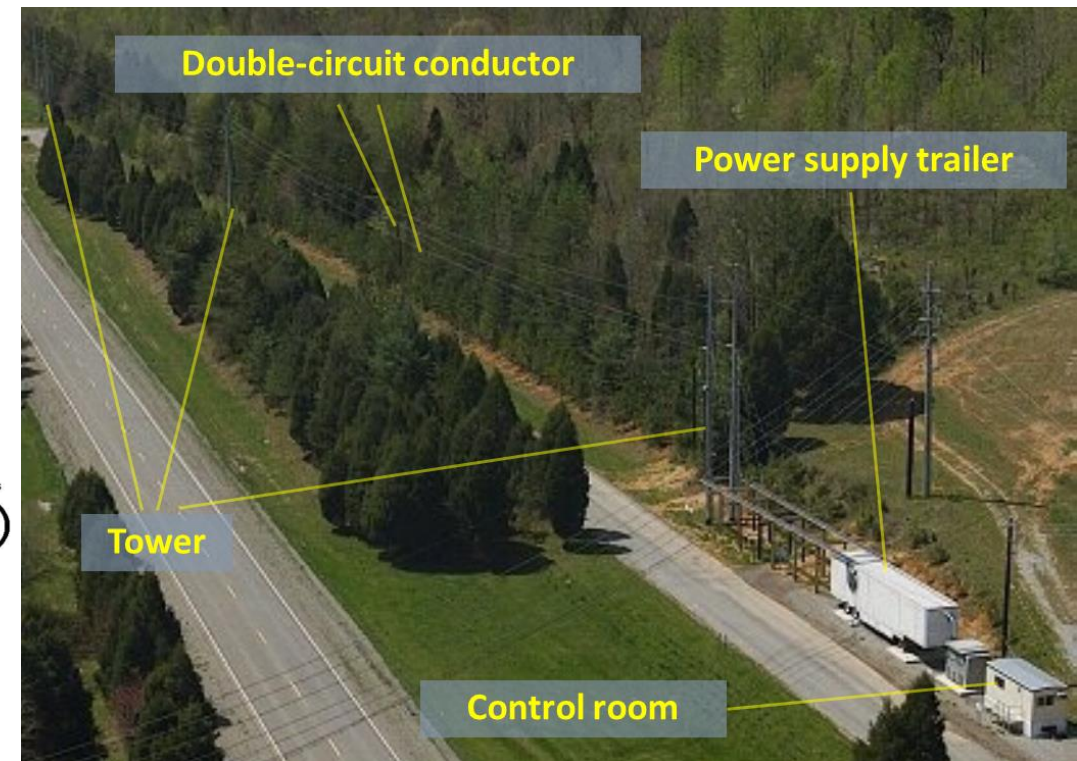
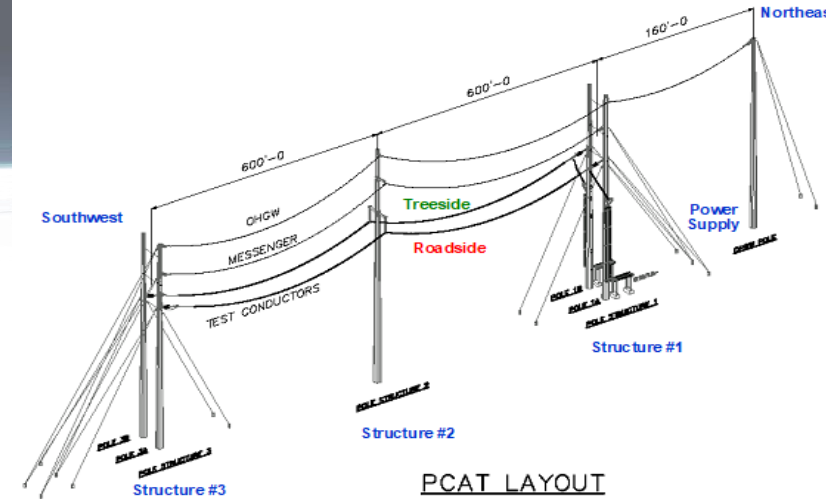
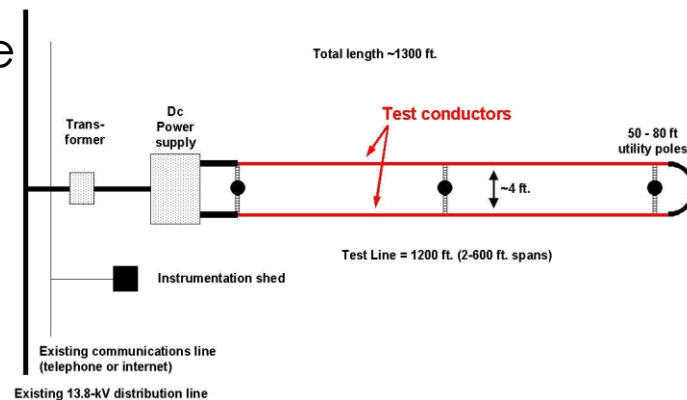

Figure 3. Proposed Phase 1 hardware insertion into current DECC schematic for integration with DECC Distributed Energy Resources.

# Power Conductor Accelerated Testing Facility (PCAT)

- ❑ Two real 600 ft spans of transmission line (3 towers)
- ❑ 2400 ft of conductors
- ❑ High current (0-5000A), low voltage (0-400V) DC supply
- ❑ Conductor temp. up to 300°C
- ❑ Comprehensive sensing & measurement equipment
- ❑ Reliable communication and data collection
- ❑ Programmable testing procedure



# Automated Battery Disassembly Secondary Use

- ❑ **Battery Automated Disassembly (Reclaim/Reuse)**
- ❑ Battery Level Diagnostics
  - ❑ Module, Stack, Cell capabilities
  - ❑ Repair and Reuse
- ❑ Automated disassembly
- ❑ Accelerated fastener defeat
- ❑ Secondary Reuse Battery Stack

