

Bo Zhang
Idaho National Laboratory
June 28, 2023

INL Capacity on Hydrogen to Grid Integration

Future clean energy –hydrogen & grid integration

- **Why hydrogen so important**

- Hydrogen is being considered as an important product because it can be produced by clean energy with great potential to decarbonize the energy system.
- It could be blended in natural gas pipelines to be co-fired with natural gas in combustion turbines, can serve as grid-scale long-duration storage, has been suggested for use with fuel cell electric vehicles (trucks and mass transit), synthetic fuels, and chemical products.

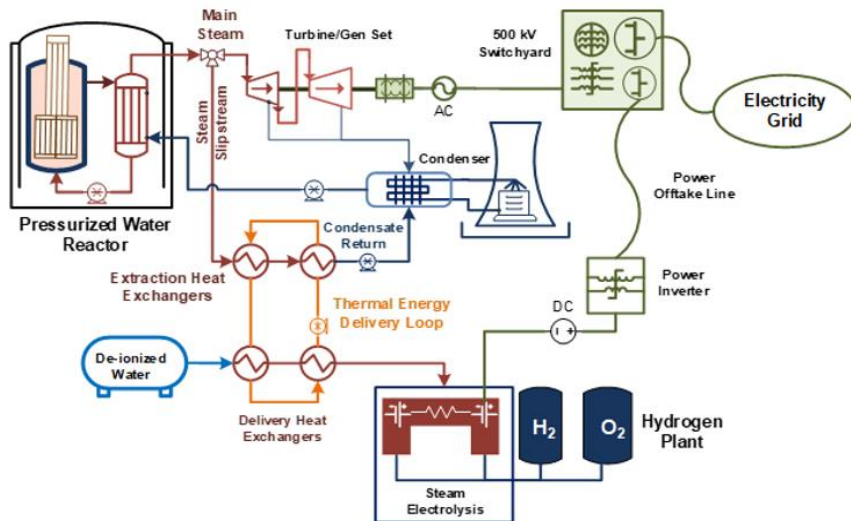

Technology Improvement & Commercialization Acceleration Path:

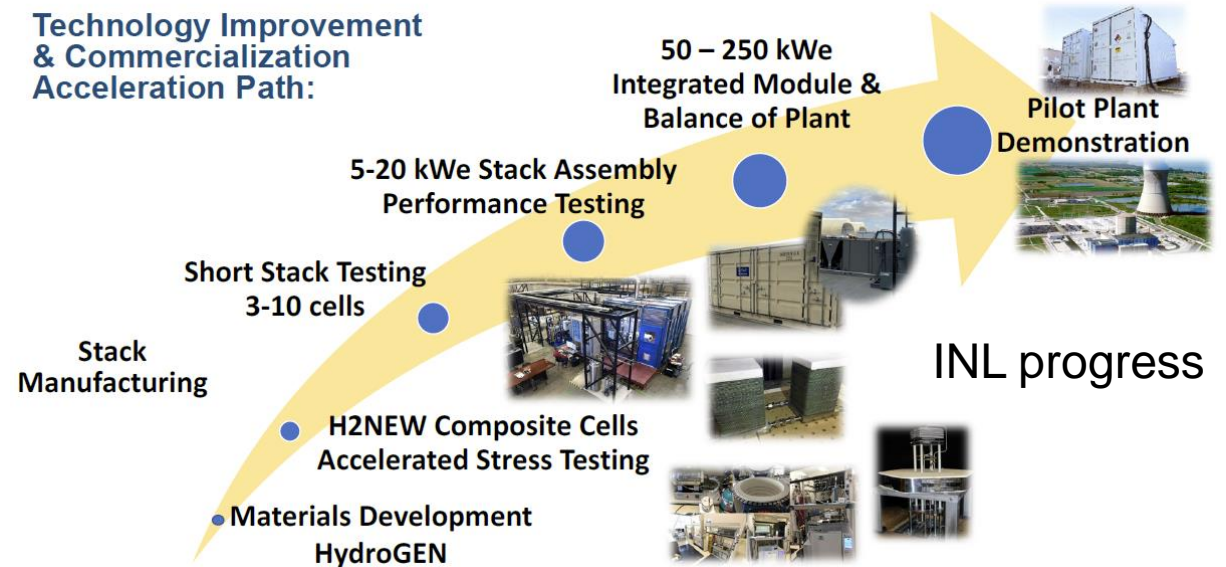

- **U.S. and global on hydrogen**

- U.S.: Aiming at \$1 per 1 kg of clean hydrogen production in 1 decade. The bi-partisan infrastructure law (BIL) recently enacted earmarked \$8 billion to support hydrogen R&D.
- EU: is building wind & HVDC with hydrogen storage in Germany, Netherland, U.K., etc. with part of the generated electricity converted to hydrogen and transported to shore using pipelines. More than 40 GW of electrolyzers is planned by 2030 in EU. (Parnell, 2020).

Overview of INL's capacity on hydrogen to grid integration

Renewables	Power	Electrolysis	Power electronics components	Control strategy	Power flow direction	Status
Hydrogen	25 kW	600-850 degC high temp. electrolyze cells	480V grid	Electrolyze generation amount control – current	Grid to hydrogen as load	In the lab, in operation
Hydrogen	100 kW		6*30kW inverter 100-1kV DC	Invert control-voltage		with container, in operation
Hydrogen	30 kW, 50kW, 250kW		/	Electrolysis stack 400-420V DC nominal	/	30kW for reversible (G2H & H2G)

100 kW hydrogen to grid integration use case

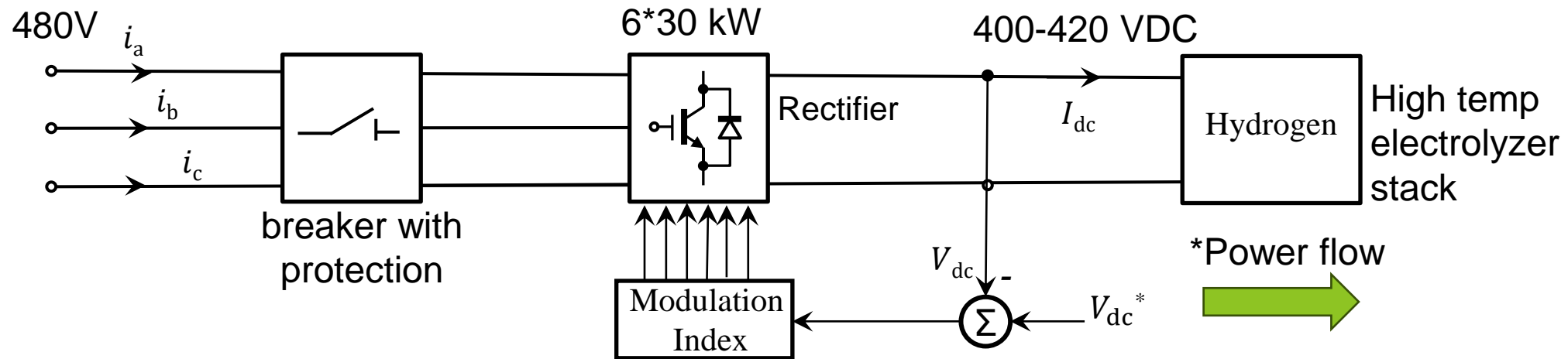

System Parameters:

- High temp electrolyzers (hydrogen) production rate: 2.69kg/hour
- Maximum DC current: up to 251A DC
- Normal 418 V DC regulate voltage
- Output power = 105 kW

*Note: the 30 kW under construction is reversible power flow



Overview of INL's lab capacity on hydrogen to grid integration



25 kW in the lab



100 kW hydrogen+rectifiers outdoor with container



30 kW reversible

Energy Systems Integration Laboratory enabling hydrogen to grid R&D

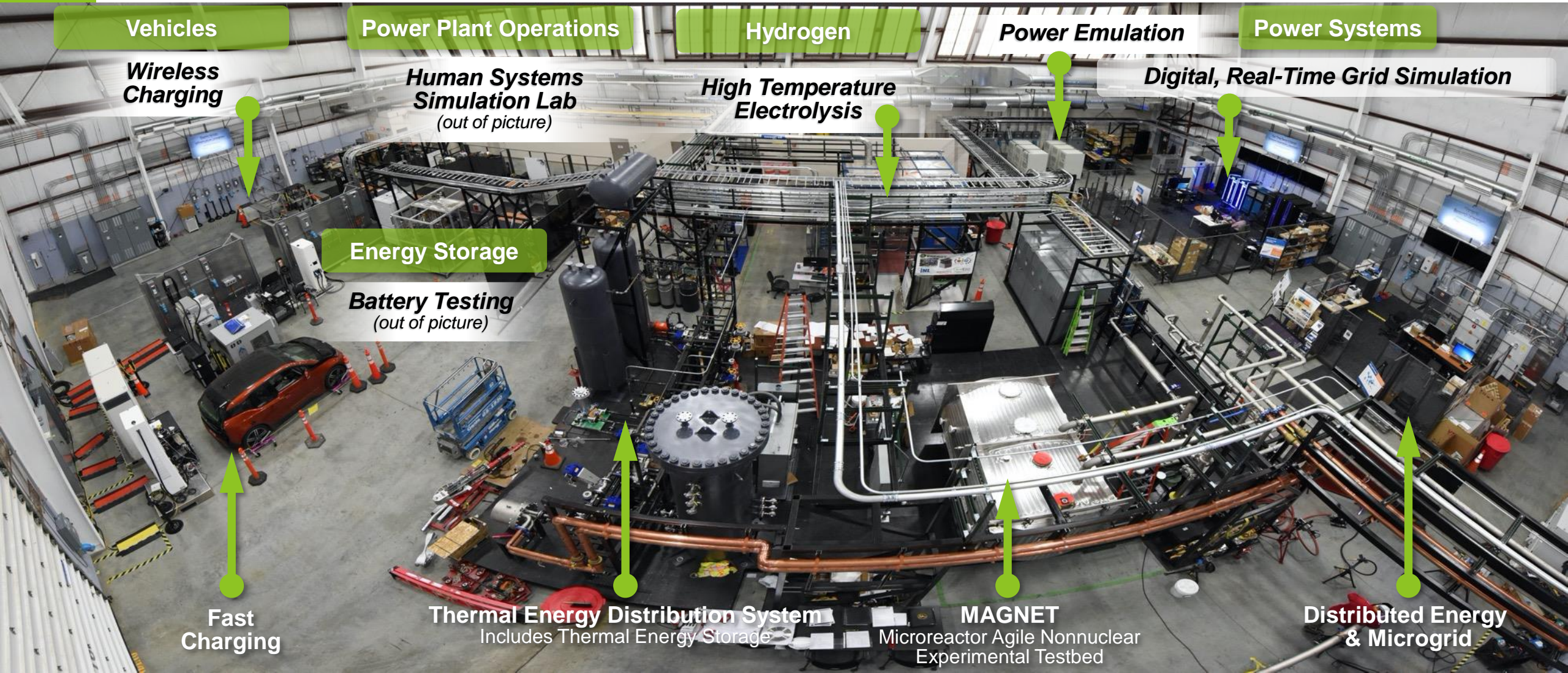

INL hydrogen to grid use case demonstration with utility

- **Four projects have been selected for demonstration with nuclear power plants (NPP) for hydrogen to grid integration.**
 - Considering both low temperature electrolysis (LTE) (~65% efficiency) using proton exchange membrane (PEM) electrolyzer and high-temperature steam electrolysis (HTSE) (>90% efficiency) using solid-oxide electrolyzer cells (SOEC)
 - Demonstrating flexible plant operations during times of peak wind or solar generation
 - Demonstrating clean hydrogen production to be used for local public transportation and industrial customers and sending the stored hydrogen to peaking gas turbines for electricity generation
- **These demonstrations will enable understanding of technological, regulatory, financial, societal, and safety aspects to scale up future clean hydrogen production**

Thermal & Electrical Integration at Prairie Island NPP in MN with Xcel 150 kW HTSE/SOEC Reversible Fuel Cells



Davis-Besse NPP 2 MW LTE/PEM in OH with Energy Harbor



Nine Mile Point NPP 1 MW LTE/PEM in NY with Constellation (former Exelon)



Palo Verde Generating Station, 15-20 MW LTE/PEM in AZ with Arizona Public Service



Back-up Slides



Idaho National Laboratory

Battelle Energy Alliance manages INL for the U.S. Department of Energy's Office of Nuclear Energy. INL is the nation's center for nuclear energy research and development, and also performs research in each of DOE's strategic goal areas: energy, national security, science and the environment.