

PNNL-38817

# Electromagnetic Transient Modeling of Large Data Centers for Grid-Level Studies

Alpha Release

December 2025

Brett A. Ross

Jim Follum

## DISCLAIMER

This report was prepared as an account of work sponsored by an agency of the United States Government. Neither the United States Government nor any agency thereof, nor Battelle Memorial Institute, nor any of their employees, makes **any warranty, express or implied, or assumes any legal liability or responsibility for the accuracy, completeness, or usefulness of any information, apparatus, product, or process disclosed, or represents that its use would not infringe privately owned rights.** Reference herein to any specific commercial product, process, or service by trade name, trademark, manufacturer, or otherwise does not necessarily constitute or imply its endorsement, recommendation, or favoring by the United States Government or any agency thereof, or Battelle Memorial Institute. The views and opinions of authors expressed herein do not necessarily state or reflect those of the United States Government or any agency thereof.

PACIFIC NORTHWEST NATIONAL LABORATORY  
*operated by*  
BATTELLE  
*for the*  
UNITED STATES DEPARTMENT OF ENERGY  
*under Contract DE-AC05-76RL01830*

Printed in the United States of America

Available to DOE and DOE contractors from  
the Office of Scientific and Technical Information,  
P.O. Box 62, Oak Ridge, TN 37831-0062

[www.osti.gov](http://www.osti.gov)

ph: (865) 576-8401

fox: (865) 576-5728

email: [reports@osti.gov](mailto:reports@osti.gov)

Available to the public from the National Technical Information Service  
5301 Shawnee Rd., Alexandria, VA 22312

ph: (800) 553-NTIS (6847)

or (703) 605-6000

email: [info@ntis.gov](mailto:info@ntis.gov)

Online ordering: <http://www.ntis.gov>

# **Electromagnetic Transient Modeling of Large Data Centers for Grid-Level Studies**

Alpha Release

December 2025

Brett A. Ross  
Jim Follum

Prepared for  
the U.S. Department of Energy  
under Contract DE-AC05-76RL01830

Pacific Northwest National Laboratory  
Richland, Washington 99354

## Abstract

The magnitude and complexity of electricity usage patterns from large data centers are having significant impacts on the operation and dynamics of the power grid; grid operators and planners require a range of specialized data center models to properly evaluate these impacts and specify technical solutions as needed. Towards addressing this need, Pacific Northwest National Laboratory (PNNL) has developed a library of electromagnetic transient (EMT) models for grid-level studies of data centers called the data center model library (DML). This report describes how the DML was created and how it may properly be used.

The models present in the DML are generic models; subject matter expertise and additional technical data are needed to modify these models before they can represent any real data center. However, they will significantly reduce the level of effort required to develop site-specific models and can serve as a common starting point to guide industry towards a more refined consensus.

Most of the models within DML are dedicated to representing the power electronics interfaces commonly used in modern data centers, such as double-conversion uninterruptible power supplies and single-phase power factor correction converters. These models are intended for use in grid-level studies and are a simplified aggregation of many small components. That said, background material on the physical and electrical design of large data centers is provided as companion material so that users can be aware of many of the details which have been omitted or streamlined as a matter of practical necessity. Additionally, guidance on the application of EMT analysis for data center interconnection studies is provided, which aids users in identifying when the DML is necessary and what sort of additional model development may be necessary for conducting real-world studies.

## Acknowledgments

This work was funded by the Department of Energy’s Office of Electricity as a part of Foundational Studies and Technical Solutions for Large Digital Dynamic Loads. We would like to extend special thanks to Sandra Jenkins and Nathaniel Horner for their support and guidance.

Development of these models would not have been possible without the expertise of a great many experts from numerous industries. The authors would like to extend special thanks to individuals who shared experiences and insights that were particularly valuable. This report does not necessarily reflect the views of the acknowledged people or their affiliates.

<b>Amazon Web Services</b>	Siva Prakash	<b>Mitsubishi Electric</b>	Kay Chen
<b>Dominion Energy</b>	Katelynn Vance Rahul Chakraborty	<b>New England Independent System Operator</b>	Kannan Sreenivasachar
<b>Eaton</b>	Keith Watson	<b>North American Electric Reliability Corporation</b>	Hasala Dharmawardena
<b>Electranix</b>	Andrew Isaacs	<b>Real-Time Digital Simulators</b>	Sumek Elimban
<b>Electric Power Research Institute</b>	Parag Mitra Lakshmi Sundaresh	<b>Schneider Electric</b>	Andre Felipe Silva Melo
<b>Electric Reliability Council of Texas</b>	Prashant Kansal Jonathan Rose Eric Meier Patrick Gravois	<b>Southern Company</b>	Sudip Manandhar Harish Sharma
<b>Idaho Power</b>	Paul Ortmann	<b>Tesla</b>	Sai Gopal Vennelaganti
<b>Microsoft</b>	Scot Heath	<b>Texas A&amp;M University</b>	Prasad N. Enjeti Xiaoyang Wang Xin Chen
		<b>University of Idaho</b>	Brian K. Johnson
		<b>Vertiv</b>	Greg Ratcliffe

Additionally, we would like to gratefully acknowledge the value of venues such as the NERC LLTF, NERC LMWG, ERCOT LMWG, IEEE PSRC, and Open Rack Compute projects. These forums have enabled open dialog and information sharing which have also been essential to the development of these models.

## Acronyms and Abbreviations

AI	Artificial intelligence
AVM	Average-value model
ASIC	Application-specific integrated circuit
BoP	Balance of plant
CPU	Central processing unit
CRAH	Compute-rack air handler
DC	Direct current
DML	Data center modeling library
EMT	Electromagnetic transient
ESIG	Energy Systems Integration Group
ESS	Energy storage system
FACTS	Flexible AC transmission systems
GFL	Grid following
GFM	Grid forming
GPU	Graphics processing unit
GSU	Generator step-up
HV	High voltage
IBR	Inverter-based resource
IT	Information technology
ITE	Information technology equipment
LLTF	Large loads task force
LV	Low voltage
LVDC	Low voltage direct current
LVRT	Low voltage ride through
NERC	North American Electric Reliability Corporation
NPC	Neutral-point clamped
MMC	Multi-level modular converter
MV	Medium voltage
OEM	Original equipment manufacturer
PCC	Point of common coupling
PFC	Power factor correction
PH	Phase
PLL	Phase-locked loop
PWM	Pulse-width modulation
SSCI	Subsynchronous control interaction
SSTI	Subsynchronous torsional interaction
SST	Solid-state transformer
SWM	Switching model
UPS	Uninterruptible power supply
VSC	Voltage-source converter

## Contents

Abstract.....	iii
Acknowledgments.....	iv
Acronyms and Abbreviations.....	v
1.0 Introduction .....	1
2.0 Data center Power Systems .....	2
2.1 Power Electronics Topologies .....	2
2.2 Balance of Plant.....	8
3.0 Electromagnetic Transient Modeling of Data centers.....	13
3.1 EMT studies for Data center Interconnection .....	13
3.1.1 Oscillatory Interactions .....	13
3.1.2 Regulation of Voltage and Frequency.....	18
3.1.3 Power Quality .....	19
3.2 Suitability of DML Specifically .....	21
4.0 Model Overview.....	22
4.1 IT Loads.....	25
4.1.1 Uninterruptible Power Supplies.....	26
4.1.2 ITE Power Supplies .....	28
4.1.3 Short-Time Load Profiles .....	32
4.1.4 Implications of DC Distribution.....	37
4.2 Climate Control Loads .....	37
4.3 Site Support Load .....	39
4.3.1 Balance of Plant .....	39
4.3.2 Energy Storage Systems .....	39
5.0 Power System Models.....	43
5.1 Inverter Model Demonstration (DML_Inverter_Demo).....	43
5.2 DC-DC Converter Demonstration (DML_DC_DC_Demo) .....	45
5.3 PFC Converter Demonstration (DML_PFC_Demo).....	46
5.4 Complete Data center Models.....	48
5.4.1 Simple Data Center (DML_DC1_Simple).....	49
5.4.2 Centralized UPS Data Center (DML_DC2_Central_UPS).....	51
5.4.3 Distributed UPS Data Center (DML_DC3_Dist_UPS).....	52
6.0 Component Models .....	54
6.1 DC-DC Buck-Boost Converter (AVM) – DC_bi_avm.....	54
6.2 DC-DC Buck-Boost Converter (SWM) – DC_bi_swm.....	55
6.3 GFM Droop Control – gfm_droop.....	56
6.4 GFM Droop Control w/ Vdc Reg. – gfm_droop_vdc .....	56

6.5	dq-Domain current regulator – <code>ireg</code> .....	57
6.6	dq-Domain Current Limiter – <code>ilim_dq</code> .....	58
6.7	3 PH Inverter, AVM – <code>inv_avm</code> .....	59
6.8	3 PH Inverter, GFL – <code>inv_gfl</code> .....	60
6.9	3 PH Inverter, GFM, Droop Control, AVM – <code>inv_gfm_droop_avm</code> .....	62
6.10	3 PH Inverter, GFM, Droop Control, SWM – <code>inv_gfm_droop_swm</code> .....	64
6.11	3 PH Inverter, SWM – <code>inv_swm</code> .....	65
6.12	Variable AI Training Load – <code>load_ai_train</code> .....	65
6.13	Playback-Based Electronic Load – <code>load_playback</code> .....	66
6.14	Lumped LV Cable, 1 PH – <code>LV_cable_1PH</code> .....	69
6.15	Lumped LV Cable, 3 PH – <code>LV_cable_3PH</code> .....	69
6.16	1 PH Rectifier with PFC, AVM – <code>pfc_avm</code> .....	70
6.17	1 PH Rectifier with PFC, SWM – <code>pfc_swm</code> .....	72
6.18	PI Controller with Anti-Windup Logic – <code>PI_AntiWindUp</code> .....	73
6.19	dq-Domain Power Calculation – <code>PQ_dq</code> .....	74
6.20	Per-unit Base Calculator – <code>pu_bases</code> .....	74
6.21	3 PH Set of 1 PH Rectifiers – <code>rect_3x_full_wave</code> .....	75
6.22	3 PH Set of 1 PH Rectifiers with Protection – <code>rect_3x_full_wave_c</code> .....	77
6.23	3 PH Diode Rectifier – <code>rect_six_pulse</code> .....	77
6.24	Stabilizer for Droop-Based GFM Control – <code>stage2_ilim</code> .....	78
6.25	Unbalance Calculation – <code>unb_rms</code> .....	78
6.26	UPS Controller – <code>ups_ctrl</code> .....	78
6.27	3 PH Contactor – <code>uv_sw</code> .....	81
6.28	1 PH Contactor – <code>uv_sw_1PH</code> .....	82
6.29	dq-Domain Voltage Regulator – <code>v_reg</code> .....	83
7.0	References.....	84

## Figures

Figure 1: Single Line Diagram of Simple Data center Design.....	2
Figure 2: Single Line Diagram for Centralized UPS Data center Design.....	3
Figure 3: Single Line Diagram of Distributed UPS Data center Design.....	4
Figure 4: Single Line Diagram of Low-Voltage DC Distribution Design.....	5
Figure 5: Single Line Diagram of Medium-Voltage Solid-State Transformer Design.....	6
Figure 6: Single Line Diagram of Medium Voltage DC Distribution Design.....	7
Figure 7: Exemplar substation layouts for data center HV substations.....	8
Figure 8: Single Line Diagrams for medium-voltage compute and cooling blocks.....	9

Figure 9: Simplified layout of LV electrical distribution within data hall. ....	10
Figure 10: Electrical room housing 28 MW of UPS capacity [20]. ....	10
Figure 11: Electrical room for medium-sized data center [21]. ....	10
Figure 12: Representative data hall [22]. This facility is rated for tens of megawatts, Tier IV reliability, and LEED Gold efficiency. ....	11
Figure 13: Representative data hall [23]. This facility uses a high power density design and features hot-aisle containment. ....	11
Figure 14: Mechanical room housing compute room air handlers (CRAH) [20]. ....	12
Figure 15: Large rooftop chiller unit for [20]. ....	12
Figure 16: Essential elements of an oscillatory interaction—excitation, damping, and at least two energy storage elements. ....	14
Figure 17: Exemplar Active Power Waveform for AI Training (left) and its frequency spectrum (right). ....	17
Figure 18: Major components of double-conversion UPS. ....	26
Figure 19: Use of DML components to represent 3-phase double-conversion UPS. ....	27
Figure 20: Simplified power supply diagram with notional voltage levels. ....	29
Figure 21: Common variations of Unidirectional PFC converters. ....	29
Figure 22: AVM for unidirectional boost PFC rectifiers. ....	29
Figure 23: Basic voltage source inverter topology (left) and its AVM (right). ....	30
Figure 24: Schematic of basic LLC converter. ....	30
Figure 25: Schematic of High Frequency Transformer for DC-DC conversion. ....	31
Figure 26: Example response of PFC converter (called the “CPS” in the figure legend) to severe AC voltage sag [49]. Annotations indicate features which may cause protection functions to operate. ....	33
Figure 27: Simulated response of double-conversion UPS configured to ride-through a severe three-phase fault [49]. ....	34
Figure 28: Exemplar site-level active power consumption from AI training load, annotations demarcate distinct stages in the training process. ....	36
Figure 29: Five ESS deployment points for modern and near-future data centers. ....	40
Figure 30: Overview of DML_Inverter_Demo Model. ....	44
Figure 31: Comparison of L-L fault response from <i>inv_gfm_droop_avm</i> and <i>inv_gfm_droop_swm</i> . ....	45
Figure 32: Overview of DML_DC_DC_Demo Model. ....	46
Figure 33: Comparison of SWM (blue) and AVM (red) response to transmission system L-L fault. ....	46
Figure 34: Overview of the DML_PFC_Demo model. ....	47
Figure 35: Comparison of fault response of <i>pfc_avm</i> (red) and <i>pfc_swm</i> (blue) fault response. ....	47
Figure 36: Comparison of fault response of PFC without ESS to provide LVRT (red) and with (blue). ....	48
Figure 37: Transmission system model used for complete data center models. ....	48

Figure 38: Overview of simple data center model.....	50
Figure 39: Overview of data center model with centralized UPS. ....	51
Figure 40: Overview of data center model with distributed UPS. ....	53
Figure 41: Icon (left) and main electrical schematic (right) of DC_bi_avm.....	54
Figure 42: Icon (left) and main hardware schematic (right) for DC_bi_swm component. ....	55
Figure 43: Icon (left) and main control elements (right) for the gfm_droop component.....	56
Figure 44: Icon (left) and main control diagram (right) for gfm_droop_vdc component.....	57
Figure 45: Icon (left) and main controls (center, right) for the ireg component. ....	58
Figure 46: Icon for the ilim_dq component.....	58
Figure 47: Icon (left) and main hardware schematic (right) for inv_avm component. ....	59
Figure 48: Main hardware schematic and major control elements for gfl_inv. ....	60
Figure 49: Hardware schematic (top) and major control features (bottom four rectangles) for inv_gfm_droop_avm component.....	63
Figure 50: Icon (left) and main hardware schematic (right) for inv_swm.....	65
Figure 51: Simplified AI training waveform and relationship with load_ai_train component parameters. ....	66
Figure 52: Icon for load_playback component and intended connectivity with PSCAD's File Read component. ....	67
Figure 53: Recommended parameters for File Read component for use with load_playback.....	67
Figure 54: Exemplar response of load_playback component to close-in 3 PH fault initiated at t = 15 s and cleared at t = 15.1 s. Active power consumption dips at time (a) as the load current is maintained within the specified limit of roughly 400 A. At time (b), the load_playback component enters momentary cessation and at time (c), which is shortly after the fault is cleared, exits momentary cessation. The ramp rate of the returning load current is also limited and ramping terminates at time (d). ....	68
Figure 55: Topology of LV_cable_3PH.....	70
Figure 56: Main hardware schematic for pfc_avm. ....	71
Figure 57: Icon (left) and main hardware schematic (right) for pfc_swm.....	72
Figure 58: Icon (left) and main control diagram (right) for PI_AntiWindUp component.....	74
Figure 59: Icon for the PQ_dq component. ....	74
Figure 60: Icon for the pu_bases component.....	75
Figure 61: Icon (left) and electrical schematic (right) for rect_3x_full_wave component. ....	76
Figure 62: Icon (left) and electrical schematic (right) for rect_3x_full_wave_c component. ....	77
Figure 63: Icon (left) and electrical schematic (right) for rect_six_pulse component.....	77
Figure 64: UPS operating modes and corresponding power flow paths [63].....	79
Figure 65: Icon for the ups_ctrl component.....	80

Figure 66: Icon for the <code>uv_sw</code> component.....	81
Figure 67: Icon (left) and electrical schematic (right) for <code>uv_sw_1PH</code> component.....	82
Figure 68: Icon for <code>v_reg</code> . ....	83

## Tables

Table 1: Data center designs and their application and grid interface.....	7
Table 2: Kinds of Oscillatory Interactions Data Centers Could Contribute to. ....	16
Table 3: Complete Power Electronic Device Models included in the DML.....	23
Table 4: Control algorithm components included in the DML.....	23
Table 5: Grid components included in the DML.....	24
Table 6: Load profile components included in the DML. ....	24
Table 7: Power electronics hardware components included in the DML.....	24
Table 8: Protection system components included in the DML. ....	25
Table 9: Signal processing components included in the DML.....	25
Table 10: Facility parameters for simple data center. ....	50
Table 11: Facility parameters for data center with centralized UPS.....	52
Table 12: Facility parameters for distributed UPS data center.....	53
Table 13: Input parameters for <code>DC_bi_avm</code> component. ....	55
Table 14: Input parameters for <code>gfm_droop</code> component. ....	56
Table 15: Input parameters for <code>gfm_droop_vdc</code> component.....	57
Table 16: Input parameters for <code>ireq</code> component. ....	58
Table 17: Input parameters for <code>ilim_dq</code> component.....	58
Table 18: Input parameters for <code>inv_avm</code> component.....	59
Table 19: Ratings-related input parameters for <code>gfl_inv</code> component. ....	61
Table 20: Controller-related input parameters for <code>gfl_ibr</code> component.....	62
Table 21: Ratings-related input parameters for <code>inv_gfm_droop_avm</code> component.....	64
Table 22: Control-related input parameters for <code>inv_gfm_droop_avm</code> component.....	64
Table 23: Input parameters for <code>load_ai_train</code> component.....	66
Table 24: Input parameters for <code>load_playback</code> component.....	69
Table 25: Input parameters for <code>LV_cable_3PH</code> component.....	70
Table 26: Device rating parameters for <code>pfc_avm</code> component.....	71
Table 27: Controller setting parameters for <code>pfc_avm</code> component.....	71
Table 28: Protection setting parameters for <code>pfc_avm</code> component. ....	72
Table 29: Input parameters for <code>pfc_swm</code> component.....	73
Table 30: Input parameters for <code>PI_AntiWindUp</code> component. ....	74
Table 31: Input parameters for <code>PQ_dq</code> component.....	74
Table 32: Input parameters for <code>rect_3x_full_wave</code> component.....	76

Table 33: Input parameters for <code>rect_six_pulse</code> component.....	78
Table 34: Correspondence of UPS controller operating modes to rectifier/bypass status.....	79
Table 35: Rating-related parameters for <code>ups_ctrl</code> component. ....	80
Table 36: Bypass control-related parameters for <code>ups_ctrl</code> component. ....	80
Table 37: Rectifier protection-related parameters for <code>ups_ctrl</code> component. ....	81
Table 38: Input parameters for <code>uv_sw</code> component.....	82
Table 39: Input parameters for <code>uv_sw_1PH</code> component.....	83
Table 40: Input parameters for <code>ireq</code> component. ....	83

## 1.0 Introduction

In recent years, the energy consumption patterns of data centers have grown considerably in magnitude and complexity, resulting in substantial consequences for the operation of the power grid at large. Grid planners and operators need models in order to proactively evaluate the effects of interconnecting data centers on the grid. These evaluations can be used to determine the performance restrictions and technical solutions necessary for reliable integration of data centers.

Many studies must be performed to evaluate grid impacts from a large data center, and different kinds of studies require different kinds of models. Of the many kinds of models needed, this work's focus is on electromagnetic transient (EMT) modeling of data centers. EMT modeling is one of the highest-fidelity forms of modeling used in power system analysis and significant expertise and technical data is required to construct a reasonable EMT model. The purpose of this work is to accelerate industry's ability to develop suitable EMT models of data centers.

Pacific Northwest National Laboratory (PNNL) has developed a library of generic EMT models, referred to as the data center modeling library (DML), using the power systems computer-aided design (PSCAD), a tool widely used in industry to simulate electromagnetic transients in power systems. The DML has been made freely available and most of this report is dedicated to explaining how DML was developed and how it may be used productively. The models in DML are intended for studying the aggregate effects of data center components on the power grid; they are of limited use for studying design problems or disturbances within the data center itself.

The DML is not a realistic representation of any one data center, nor is it intended to be. Rather, it is a reasonable starting point for the development of site-specific models for use in grid-level studies. Site-specific models must be developed using subject-matter expertise and site-specific technical data. A wide range of common data center components have been implemented along with organizational features intended to reduce the additional labor needed to make the models site specific. Lessons learned, typical design practices, and opportunities for simplification have been documented to aid engineers in managing the potentially impractical level of complexity involved in EMT model development.

This report's contents are organized as follows. Section 2.0 describes the design of power systems used within data centers and presents six aggregated site models which can be used to represent most modern or near-future data centers. Section 3.0 discusses practices for EMT modeling of data centers, explaining the situations in which it is beneficial to undertake the time-consuming process of performing an EMT study and the kinds of risks and challenges such a study can articulate. Section 4.0 describes in detail how the different components of data center power systems can be represented in an EMT model and how this relates to the components provided in DML. Section 5.0 describes the power system models included in DML and documents their functionality. Section 6.0 documents the functionality of the individual component models included in DML.

## 2.0 Data center Power Systems

The purpose of this section is to provide a succinct overview of those aspects of data center power systems that are most relevant for grid level dynamic studies. This highlights the major components needing representation in various studies and outlines current and near-future archetypes for data center design.

### 2.1 Power Electronics Topologies

Most grid-level EMT studies involving data centers employ relatively simple representations of the site distribution systems, with most of the model fidelity being concentrated on the power electronics that support information technology equipment (ITE). The power electronic architectures for most data centers fit into one of six designs—these are described below, and single-line diagrams of the proposed aggregated EMT models are provided. The first three designs are in use today and case files for them are included in DML. The later designs range from near future (e.g., within 2 years) to futuristic (e.g., within 10 years) and the alpha release of DML does not include all of the component models required to represent these systems. A more detailed discussion of the reasoning behind selecting the specific components shown within the single-line diagrams may be found in Section 4.0.

#### Design 1: Simple

The simple data center design is primarily associated with cryptomining operations and seldom used for other applications (Figure 1). Compared to most other data centers, reliability is less critical and the costs associated with the electric plant are more influential on the site's economic viability. AC/DC conversion at the rack level is done at 240 V and diode-based power factor correction (PFC) converters are used. No uninterruptible power supply (UPS) or on-site backup generation is present.

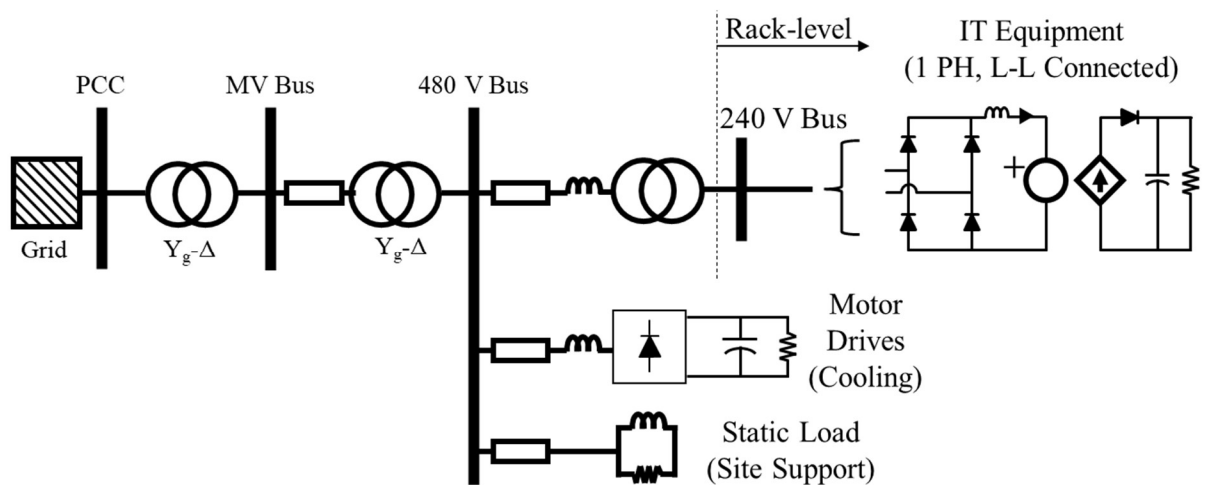

Figure 1: Single Line Diagram of Simple Data Center Design.

#### Design 2: Centralized UPS

The centralized UPS design is likely the most common for many data centers currently in operation (Figure 2). ITE is located behind large (~1 MVA each) three-phase UPS to protect it

from grid disturbances and ensure continuity of service in the event that the data center must disconnect from the grid and start up local backup generators. While not considered in grid-level studies, high voltage (HV) and medium voltage (MV) systems are equipped with numerous alternate feeds and automatic transfer schemes. Data centers of this design are often designed for concurrent maintainability and achieve Tier 3 reliability as defined by the Uptime Institute [1]. On-site generation is provided and consists of either distributed diesel engines or large steam or natural gas turbines. Traditionally, these are never paralleled with the grid and are only used after the data center has disconnected from the grid following a disturbance. The UPS batteries are used to supply the load in the interim period. However, a recent trend has been for on-site generation to become part of the grid’s generation pool and to provide occasional support in order to manage grid-level generation shortages or transmission congestion.

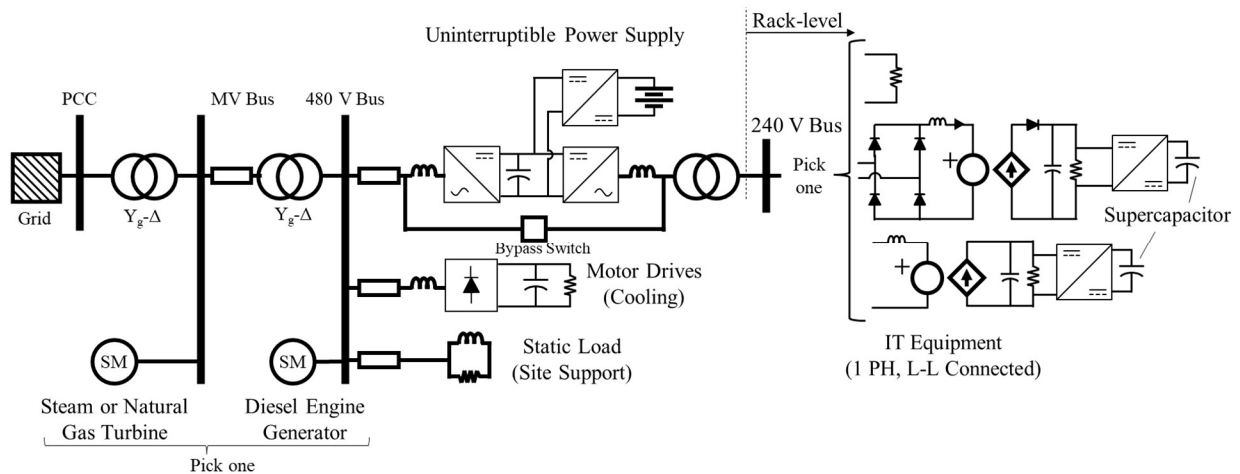

Figure 2: Single Line Diagram for Centralized UPS Data Center Design.

A single UPS serves a number of IT racks, with modern per-rack power demands typically in the tens of kilowatts for traditional applications and over 100 kilowatts for high-performance computing (i.e., AI training) applications. The rack level power supplies may be modeled as a simple resistive load (potentially with a time-varying demand) unless the UPS is operated with the bypass switch closed. Single phase power supplies are represented in Figure 2 using the average-value model (AVM) for both unidirectional (diodes shown) and bidirectional (no diodes shown) models for a voltage-source converter to illustrate that either may be used. More detail on this is given in Section 4.1.

There are many variations on the centralized UPS design on a site-to-site basis. Some or all of the cooling load at a site may be behind UPS as well—this is increasingly common in artificial intelligence (AI) applications as high heat densities and hardware costs make the risks associated with temporary cooling interruptions more significant. Some of the motor load may consist of line-connected induction motors rather than motor drives.

Supercapacitors at the rack level are newly come to market [2] and are present at few sites at the time of writing. Their primary application is smoothing of rapid changes in compute load (e.g., due to hyperscale AI training) in order to reduce both site- and grid-level disruptions. However, they may also come to be utilized to improve the site’s ride-through capabilities as well.

### Design 3: Distributed UPS

The distributed UPS design philosophy is used for some new data centers; Meta is a notable adopter of this design [3] [4] [5]. Battery backup and support of the IT load is achieved using rack-level storage, meaning that the UPS function is distributed at the rack-level. This results in significant cost savings owing to the lack of double conversion UPS but does result in information technology (IT) load being exposed to power quality disturbances such as voltage excursions and harmonics. Whether or not this meaningfully affects site reliability will depend on local power quality conditions and the design of site-level protection and automation schemes.

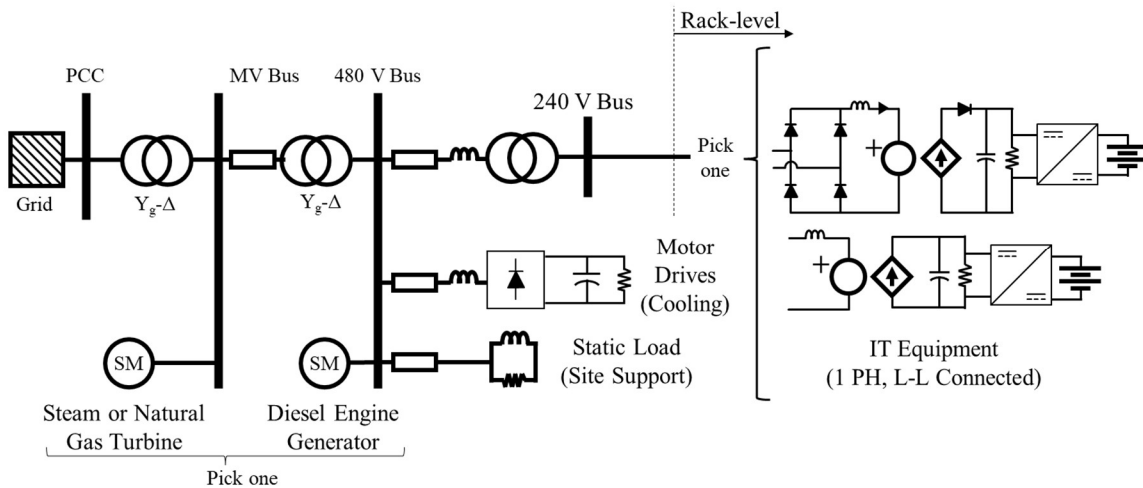

Figure 3: Single Line Diagram of Distributed UPS Data Center Design.

Backup generation at distributed UPS sites is operated in a manner similar to that at centralized UPS sites; the data center disconnects in response to grid disturbances that threaten process reliability, rack-level batteries provide continuity of power for IT loads, and local generation is rapidly brought online to serve the load.

### Design 4: Low-Voltage DC Distribution

The remaining three designs are based on DC distributions and are major R&D foci for data center suppliers [6] [7] [8] [9] [10]. The technical benefits for adopting DC distribution in power electronics-rich environments have long been recognized in research [11] and have even seen nascent industry interest in the past [12] [13], but high costs and low supply chain maturity have slowed adoption. The unique requirements and resources of hyperscale AI data center developers have altered this paradigm.

Increased power density needs of AI platforms are the primary motivation for original equipment manufacturers (OEMs) and data center developers to expend significant capital on developing DC distribution systems—present-day graphics processing unit (GPU) racks attain 120 kW, and prototypes up to 1 MW have been developed and planned for 2027 [10] [7]. Training larger and more sophisticated AI models requires more compute resources, and a high degree of low-latency connectivity between individual processors is required for good performance during training. The latency and bandwidth constraints this introduces make it prohibitive to continue spreading compute resources over a wider area, and the result is a strong demand for the high power densities which only DC power systems can provide.

The low voltage DC (LVDC)<sup>1</sup> distribution design is a central R&D focus for many OEMs [6] [14] and is in the prototype stage (Figure 4). It is also seen as somewhat of a stepping stone to the later two architectures, which require additional R&D and field experience with operating DC distribution systems. From an aggregated perspective, this design may be viewed as a variation of the centralized UPS design wherein the output inverter is absent and the DC link voltage (either 400 V or 800 V, depending on the vendor [10] [15]) is distributed directly to individual racks of IT equipment. The design of the 480 V rectifiers will likely be similar to those employed in double-conversion UPS today. The rack-level power supplies are no longer single-phase AC/DC converters but rather DC/DC converters which step the 800/400 VDC down to 50 VDC for ITE to use.

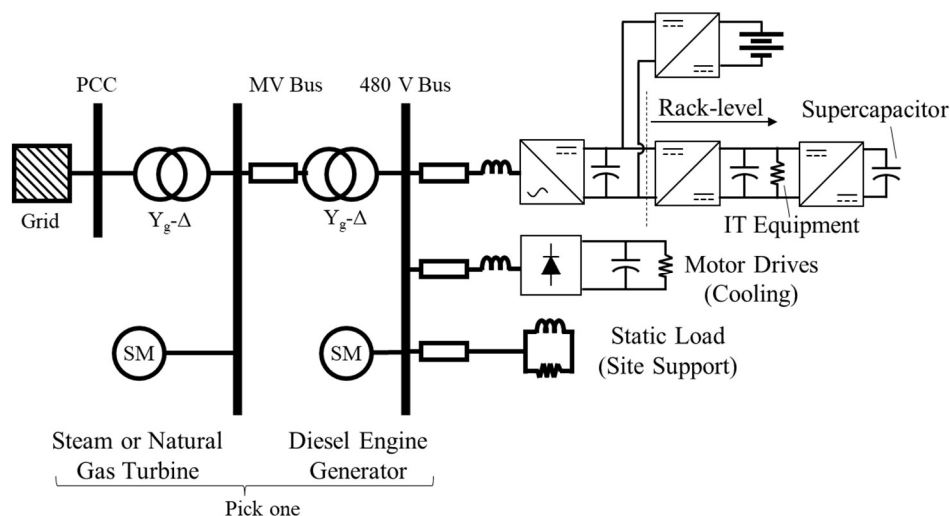

Figure 4: Single Line Diagram of Low-Voltage DC Distribution Design.

Much like in a double-conversion UPS, a battery system is integrated at the 400/800 VDC level. The battery backup may be used for load smoothing, grid support, ride-through, backup power, or a mix of all three. Supercapacitors at the rack level may also be used for load smoothing, which could reduce the necessary battery capacity and/or extend battery lifetime. Batteries could also be installed at the rack level, as is done in the distributed UPS design. On-site inverter-based generation may also be connected to the LVDC network (rather than through its own set of AC/DC converters and step-up transformer). This could reduce losses and capital costs but may introduce operational complexities and reliability concerns relating to shared points of failure.

In principle, the motor drive rectifiers could also be eliminated by supplying the drive inverters directly from the LVDC distribution. However, rectifiers for drives are not necessarily major drivers for site-level cost or limitations. Commercial drive rectifiers may not be compatible with the DC supply conditions provided by the LVDC network, and otherwise beneficial drive features such as flying restart may become a source of complexity. Still, potential benefits from making the inertia of cooling motors available as a form of short-term energy storage (and savings in the form of reduced rectifier capacity and DC link capacitance) are worth further investigation.

<sup>1</sup>Here, we use the term LVDC distribution to refer to distribution at DC voltages ranging from 600 to 4000 VDC. In datacenter industry literature, this is often referred to as HVDC. In this report, we delineate LV, MV, and HV levels within the context of electric power systems.

### Design 5: Medium-Voltage Solid-State Transformer

Power density may be further increased beyond the LVDC design by replacing the MV to LV transformers and LVAC cables with a MV AC/DC converter and DC/DC conversion stage to step down the MVDC to LVDC. Solid-state transformer (SST) technology is viewed as a promising solution for achieving these functions (Figure 5).

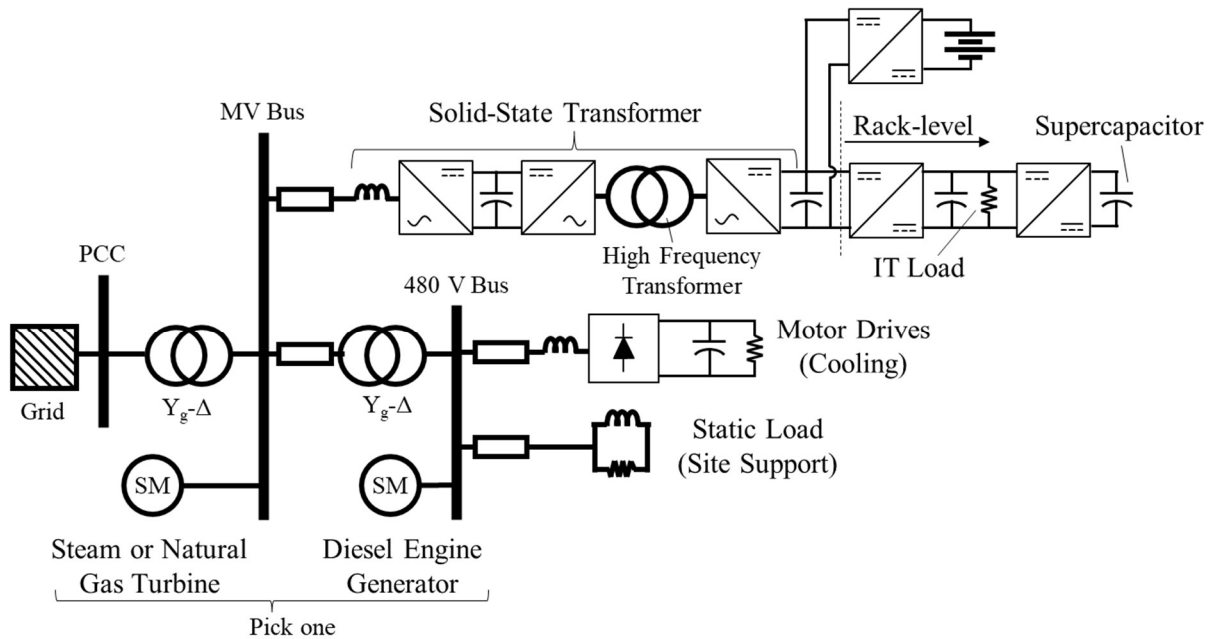

Figure 5: Single Line Diagram of Medium-Voltage Solid-State Transformer Design.

The SST replaces the MV to LV transformer and its output stage replaces the rack-level AC/DC converter employed in the LVDC distribution design—the SST directly provides the 400 or 800 VDC that is then distributed to the racks. The remaining downstream architecture is similar to the LVDC design. The number of racks that can be supplied with a single SST is uncertain given the ambitious R&D targets set in place for both SST deployment and AI rack power density. With a medium-voltage AC input, economical design of an SST rated for tens of MVA is plausible, meaning that a single SST will likely be able to serve more racks than the LV rectifier used in the LVDC distribution design.

For both the LVDC distribution and MVDC SST designs, improving the LVDC voltage to above 1 kV (e.g., 1.5 kVDC) has been identified as an R&D target. While this may require significant product development and improvements to personnel safety measures, the resultant changes from the perspective of EMT modeling may not significantly affect the aggregated model to be used.

### Design 6: Medium-Voltage DC Distribution

The MVDC distribution design is the logical next step from the MVDC SST design—power density may be further increased by replacing the MVAC distribution with an MVDC distribution system (Figure 6). In terms of the scope of product development required, the MVDC design is a significant step involving cables, busbars, switchgear, circuit breakers, etc. to a much greater extent than in the LVDC distribution or MVDC SST designs. Thus, while data center suppliers

expect to begin deploying the LVDC and SST technologies in the field within the next several years, MVDC-based data centers are likely further away from seeing field service.

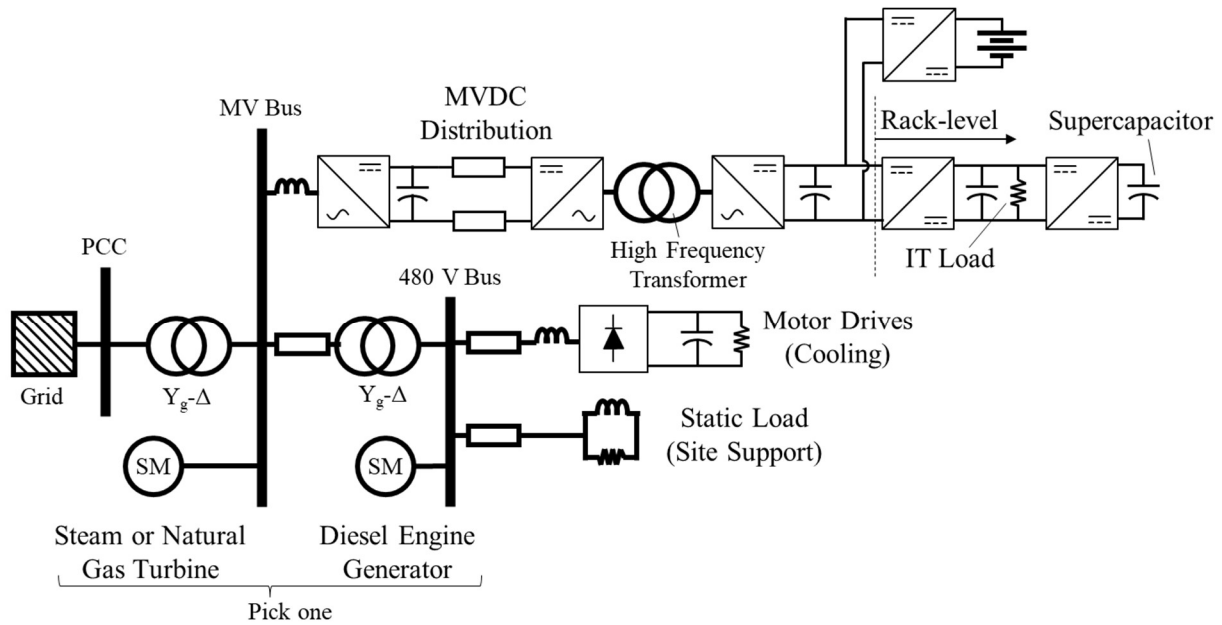

Figure 6: Single Line Diagram of Medium Voltage DC Distribution Design.

Observe that, from an aggregate modeling perspective, this is not radically different from the MV SST design—the primary difference is that the MV cable is now located after the MV AC/DC conversion stage; a high frequency transformer is still likely to serve as an attractive option for reducing MVDC to LVDC for rack-level distribution.

Table 1 summarizes the six data center designs introduced. Observe that evolution in data center power electronics is being driven by AI hyperscalers, and that future designs are trending towards the use of a 3 phase (PH) active front-end design, similar to that used in inverter-based resources (IBRs).

Table 1: Data center designs and their application and grid interface.

Design	Primary Application	ITE Grid Interface
1: Simple	Cryptomining	1 PH ITE Power Supplies
2: Centralized UPS	Modern data centers	3 PH active rectifier
3: Distributed UPS	Modern data centers	1 PH ITE Power Supplies
4: LVDC Distribution	Near-future (<5 yr) AI hyperscalers	3 PH active rectifier
5: MV SST	Near-future (<5 yr) AI hyperscalers	3 PH active rectifier
6: MVDC Distribution	Future (>5 yr) AI hyperscalers	3 PH active rectifier

For grid level studies, further simplifications of all these architectures may be possible—many grid-level studies of power electronics use highly simplified representations of any power conversion stages beyond those directly connected to the grid. In four of the six designs considered, the ITE equipment is interfaced with the grid via a 3-phase converter with energy storage. Further study and development of these converters may allow for existing modeling approaches for IBRs to be heavily utilized for representing data centers in grid-level studies. Early-stage performance requirements for large loads [16] [17] are similar in many respects to

IBR performance requirements, such as those in IEEE Std 2800 [18] and NERC PRC-029-1 [19].

Aside from emergent grid integration issues such as ride-through, designs 2 and 3 are highly mature from the data center perspective. Many data centers have highly stable electricity demand and use few or none of the high-power AI racks which are driving the power density requirements and investment in DC distribution systems. In such cases, designs 2 and 3 are attractive options, especially when reliability is paramount and thus appetite for less proven technology is lower. Thus, it is expected that these designs will continue to be used in a significant fraction of new data centers for the foreseeable future.

## 2.2 Balance of Plant

In Section 2.1, the topology of the HV, MV, and LV networks has been highly simplified in accordance with the DML's focus on grid-level studies. In this section, a brief description of AC HV, MV, LV networks in data centers is given so that DML users may be somewhat familiar with the detailed topologies that aggregated models are based on.

Generally speaking, the HV and MV power systems employed in large data centers are similar to those used in mission-critical industrial facilities or urban areas—numerous redundancies and alternate feeds are provided to accommodate faults and equipment outages. Space saving measures such as high-density substation layouts and switchgear are employed. Figure 7 illustrates two HV substation layouts sometimes used in data centers. These layouts are similar to distribution substations used by many utilities.

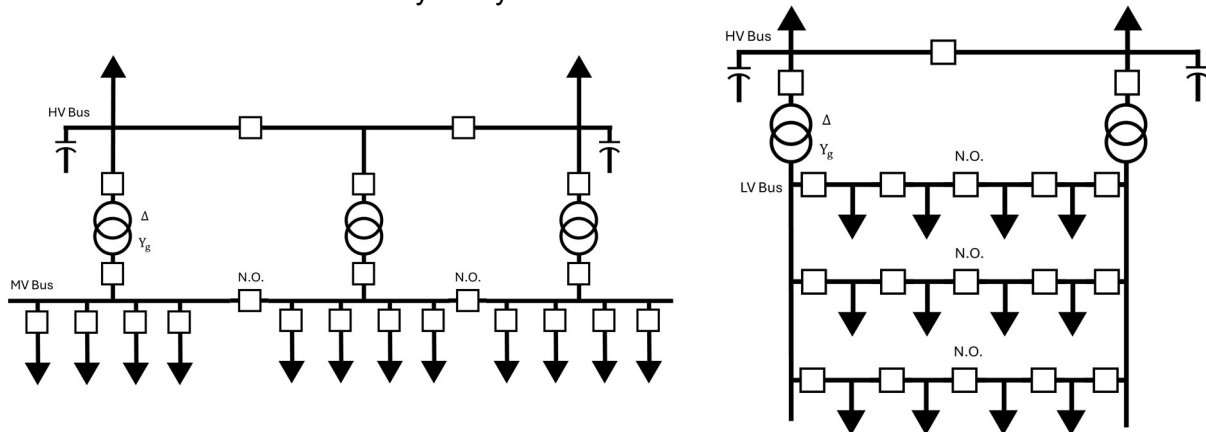

Figure 7: Exemplar substation layouts for data center HV substations.

The protection and control of these substations is also similar to typical utility practices; transformers and busbars are protected from faults using current differential protection. Short feeders may be protected either via time-inverse overcurrent or current differential. Large power transformers are equipped with mechanical protections and gas monitoring, and switchgear is equipped with arc flash protection.

Fast bus transfer schemes and networked distribution systems are less common as the UPS provide continuity of service to critical loads, reducing the need for the protection system to perform high-speed fault clearing or reconfiguration. That said, both automatic and manual reconfiguration schemes are widely used to ensure continuity of service even in the event of multiple outages or failures.

At the LV level, large data centers are often constructed by repeated “blocks” each rated for several megawatts each (Figure 8). Each block generally may be fed by two different MV feeds and, if backup generation is distributed (as is often the case), backup generation is connected (either at the MV or LV level). UPS are employed at this stage, often in redundant pairs and with each carrying a portion of the total load. In grid-level EMT studies, these UPS may be combined into a larger equivalent (this is the approach used in the DML examples). Cooling blocks also use UPS in larger data centers; the tolerance for cooling interruptions in hyperscale data centers is ever-decreasing as racks operate at higher power densities.

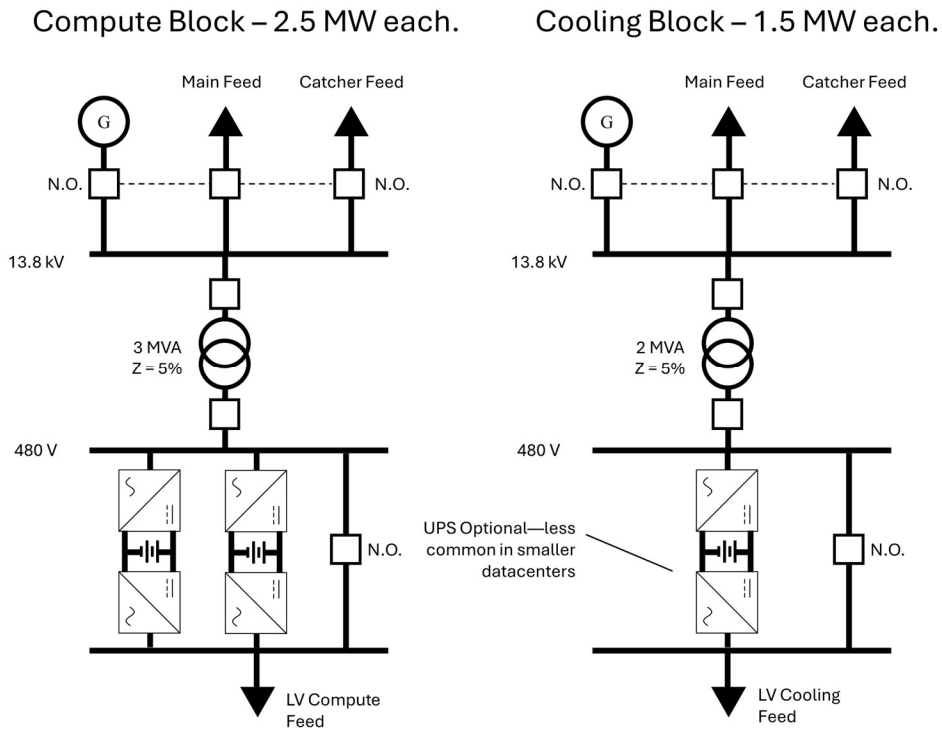

Figure 8: Single Line Diagrams for Medium-Voltage Compute and Cooling Blocks.

The low-voltage distribution equipment is then usually located within a dedicated electrical room located adjacent to the data hall where the ITE is located. Figure 9 illustrates the basic connectivity and arrangement of LV distribution equipment in relation to the data hall.

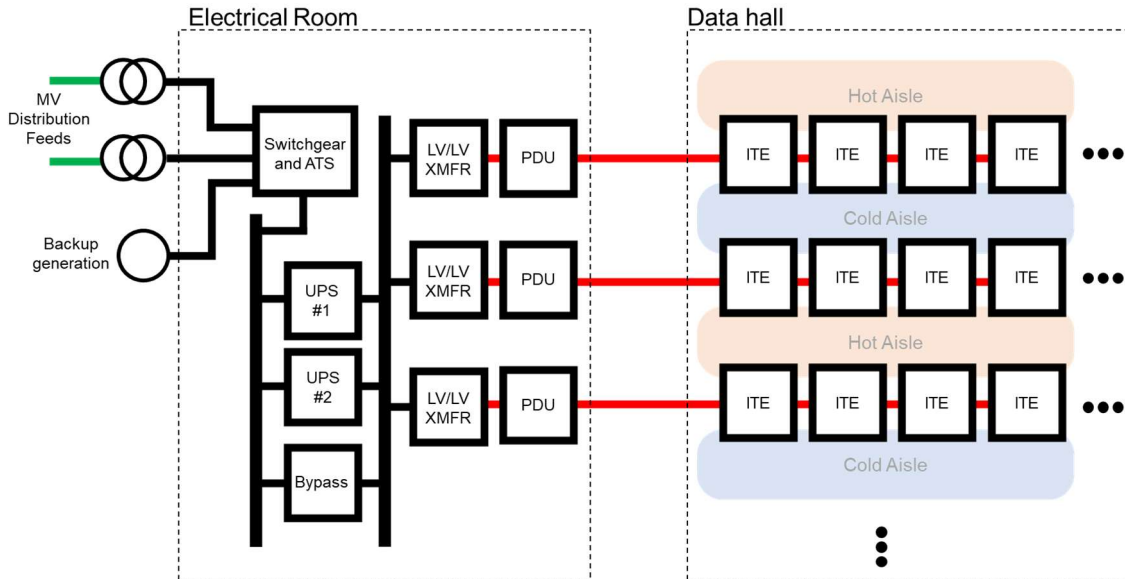

Figure 9: Simplified Layout of LV Electrical Distribution within Data Hall.

Power distribution units (PDUs) serve as switchboards for the LV cables feeding racks and are the primary means for monitoring and automation of power distribution at the rack level. PDUs range in functionality from basic high-quality power strips to automation and control platforms that provide high-fidelity monitoring and aggregation of a variety of electrical and mechanical sensory data from within the data hall. Thus, while PDU are a critical component of the site-level operations and monitoring, their relevance to grid-level EMT studies is limited.

Figure 10 and Figure 11 illustrate typical arrangements and installation conditions for LV distribution equipment in the utility room of a modern data center. Connections are usually made with cable located in metal conduit, with incoming feeds usually coming from MV equipment located outdoors and outgoing feeds running to the adjacent data hall. In high-density or space constrained sites, MV equipment may also be located inside.



Figure 10: Electrical Room Housing 28 MW of UPS Capacity [20].



Figure 11: Electrical Room for Medium-Sized Data Center [21].

Figure 12 and Figure 13 illustrate typical installation conditions within the data hall. Most of the floor space is dedicated to ITE racks. Both drop ceiling and raised floor are commonly employed to provide passage for air supplied by cooling-rack air handlers (CRAH), as well as potential passage for power cables, piping for any rack-level cooling, and communications cables.

Overhead raceways provide another path for routing this infrastructure. There are many different practices for how air flow and pipe/cable routing are handled at the data hall level [5].

As first indicated in Figure 9, ITE racks are arranged into rows and organized into hot and cold aisles. Rack-level cooling admits air from cold aisles and emits it into hot aisles; ports for user interactivity are located on the cold side of the rack and any hazardous high-power connections are located on the hot side. Some form of thermal barrier between aisles is generally used, Figure 13 illustrates the application of hot-aisle containment—the areas between aisles are enclosed in transparent panels and heat is exhausted through either the ceiling or floor<sup>1</sup>.



Figure 12: Representative Data Hall [22]. This Facility is Rated for Tens of Megawatts, Tier IV Reliability, and LEED Gold Efficiency.



Figure 13: Representative Data Hall [23]. This Facility uses a High Power Density Design and Features Hot-Aisle Containment.

Figure 14 and Figure 15 illustrate typical installation conditions for the two main sources of cooling load, compute room air handlers (CRAH) (left) and chillers (right). CRAH are located in rooms adjacent to the data hall and provide the data hall with air that is regulated in terms of its temperature, flow rate, humidity, and pollution. The mechanical room usually houses automation controllers and support systems for both air and coolant handling. In large data centers, centralized chilled water plants are the primary method for rejecting heat produced by ITE<sup>2</sup> to the outside environment. Heat exchangers throughout the facility (e.g., with the CRAH and any rack-level liquid cooling) are dedicated to transferring heat away from ITE and into coolant loops that flow through outdoor chillers. In large data centers, plant-scale chillers are typically located on the facility rooftop.

<sup>1</sup>Air flow velocities in data halls are usually too high for heat's natural tendency to rise to be a major design factor [5].

<sup>2</sup>The majority of electricity consumed by ITE is converted into heat. As a result of the thermal performance limitations of modern ITE and cooling systems, coolant temperatures are generally too low to support other processes (e.g., district heating or steam generation) [5]. However, market demands for higher power density are driving adoption rack-level liquid cooling solutions [92] and high-temperature semiconductors (e.g., SiC and GaN) [93]. These technologies permit higher coolant temperatures which may supply other processes.



Figure 14: Mechanical Room Housing Compute Room Air Handlers (CRAH) [20].



Figure 15: Large Rooftop Chiller Unit for Data Center [20].

The pictured chiller is rated for 345 tons, meaning that the cooling water pump rating is likely about 1.5 MW. Large design margins are used when sizing cooling capacity, so the typical power demand for this chiller is likely to be significantly less than 1.5 MW.

## 3.0 Electromagnetic Transient Modeling of Data centers

In Section 2.0, as part of an overview of data center power systems, we have discussed some simplifications, common practices, and assumptions that may be employed to manage the potentially prohibitive level of detailed modeling involved in EMT modeling of large data centers, which contain tens of thousands of high-power components. As with many practical applications of EMT modeling, a clear understanding of study objectives and a series of pragmatic assumptions is required to complete studies in a reasonable time frame. In this section, we will discuss some potential applications for grid-level EMT modeling of data centers and the kind of EMT models that are suitable for conducting them. This discussion is aimed towards studies that consider the impacts of the data center(s) under study on the grid, rather than studies of site-level issues.

In subsection 3.1, general practices for determining the need and scope of EMT studies for data center interconnection studies are discussed. Subsection 3.2 addresses the applicability of the DML specifically to these studies.

### 3.1 EMT studies for Data center Interconnection

The details of EMT models are tailored to the kinds of study they are used for. In developing the DML, we considered a number of power system studies which might be conducted as a part of the data center interconnection process. The scope of studies discussed here is based on the scope of issues discussed in NERC's recent large load risk assessment [24] as well as a table developed by Electranix [25]. This overview is also informed by ongoing activities within the ESIG Large Loads Task Force and the NERC Load Modeling Working Group, both of which are developing data center modeling guidelines for grid-level studies. These will likely be publicly released in 2026.

Here, data center interconnection studies are organized into three categories: oscillatory interactions, voltage and frequency regulation, and power quality. This list omits studies which are clearly outside the domain of EMT analysis, such as load forecasting or evaluating steady-state capacity limits.

#### 3.1.1 Oscillatory Interactions

The category of oscillatory interactions encompasses a wide range of scenarios, and the potential role of the data center and related modeling requirements varies. Figure 16 illustrates the essential elements of any oscillatory interaction, along with examples of the grid components and the elements they play a role in. **bolded and underlined** items represent the data center components that can contribute to an oscillatory interaction. The current source with a series RLC circuit directly represents a circuit used to study harmonic resonance with shunt capacitors, but it serves as a convenient analog for other forms of oscillatory interaction.

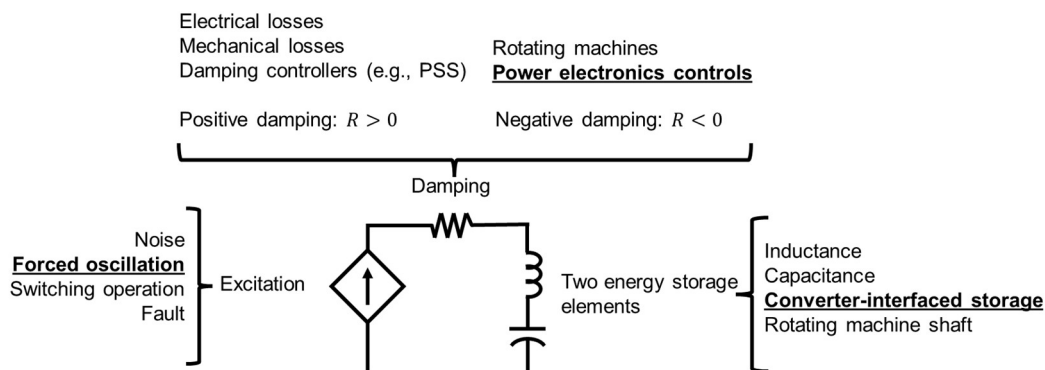

Figure 16: Essential Elements of an Oscillatory Interaction—Excitation, Damping, and at Least Two Energy Storage Elements.

### Energy Storage Elements

Any oscillation involves energy exchange between at least two different forms of energy storage. The frequency of the oscillation is dictated by the time constants associated with the energy storage mechanisms. Purely electrical interactions (as opposed to electromechanical or control interactions) involve capacitors and inductors. Electromechanical interactions involve the kinetic energy stored in the masses of rotating machines. Even in the case of oscillatory interactions involving many devices (e.g., interarea oscillations), the devices involved can usually be lumped into one of two groups (e.g., the northern grid or the southern grid).

### Damping

In the simple model of Figure 16, the energy storage elements are lossless—they exchange energy but do not cause any change in the total energy present in the system at a given time. The damping component represents the energy that is introduced or dissipated as energy flows between the two energy storage components. The total damping is the sum of the contributions from many devices, some of which introduce positive damping (i.e., they absorb energy) and some of which introduce negative damping (i.e., they supply energy). If the total damping is negative, any disturbance, no matter how small will result in instability (hence why “noise” is a valid source of excitation for an oscillatory interaction of concern). If an oscillation is lightly (and positively) damped, then the practical concern is that the oscillations produced by step changes (e.g., switching operations and faults) will be long-lasting and that oscillations produced by continuous inputs (e.g., noise or a forced oscillation) will have a large amplitude at certain locations in the system.

Component losses (e.g., mechanical friction, electrical resistance) are the main source of positive damping in power systems. Active components (e.g., rotating machines and power electronics) can provide either positive or negative damping and often produce a significant quantity of negative damping over some range of subsynchronous frequencies [26] [3] [27] [28]. In a real power system, the total damping is not the simple sum of that from individual elements but rather heavily affected by the network topology. The fact that a particular plant or load has negative damping is not inherently a problem—an individual device or plant may contribute negative damping (large or small) at subsynchronous frequencies and yet have a negligible impact on the total effective damping of a given oscillation<sup>1</sup>.

<sup>1</sup>In a recent Level 2 Alert, NERC has recommended that Transmission Operators should establish design requirements for Large Loads that ensures they are “designed in a way to increase damping of the listed

## Excitation

Excitation introduces energy into the system, causing an oscillation. Its behavior is assumed to be independent of the system damping or dynamics of the energy storage elements, hence its depiction in Figure 16 as an ideal current source. The implementation of the excitation and its underlying assumptions vary based on the kind of interaction of concern:

1. Concerns that the net damping of a power system mode may be too low—in this case, the excitation may be a simple test signal, or methods which neglect excitation entirely (e.g., the use of transfer functions) may be employed.
2. Concerns that forced oscillations may attain high amplitudes (e.g., within a turbine shaft) and/or travel significant distances (e.g., due to the coincidence of the forced oscillation frequency with an interarea mode).
3. Concerns that intermittent disturbances may cause long-lasting oscillations

In practice, grid-level studies frequently make use of EMT simulation for (1), as this tends to be a less time-consuming approach to quickly screen for issues.

---

mode shapes for known power system oscillations” [94]. The majority of loads and generators connected to the power system do not and cannot meet this criteria—many will, theoretically, decrease the damping of subsynchronous modes. However, the effects are insignificant in the overwhelming majority of cases.

Table 2: Kinds of Oscillatory Interactions Data Centers Could Contribute to.

Phenomenon	Excitation	Negative Damping	Energy storage	
			Element 1	Element 2
SSTI due to forced oscillation exciting shaft modes	<b>Data center load fluctuations</b> with content in torsional frequency range (10 to 50 Hz)	N/A	Gas/Steam Turbine Shaft section	Gas/Steam Turbine Shaft section
Forced oscillation exciting interarea modes	<b>Data center load fluctuations</b> with content in interarea frequency range (0.1 to 1 Hz)	N/A	Group of rotating machines in one region	Group of rotating machines in another region
Forced oscillation exciting local modes	<b>Data center load fluctuations</b> with content in local frequency range (0.5 to 5 Hz)	N/A	Rotating machines at a specific plant	Rotating machines in the bulk grid
SSTI due to decreased damping of shaft modes	Noise/switching operation	<b>Data center power electronics</b>	Turbine Shaft section	Turbine Shaft section
SSCI between data center power electronics and other power electronics devices.	Noise/switching operation	<b>Data center power electronics</b> / IBR plant, HVDC line, FACTS device	<b>Data center power electronics</b>	IBR plant, HVDC terminal, or FACTS device
SSCI between power electronics and local generation plant	Noise/switching operation	<b>Data center power electronics</b>	Rotating machines at a specific plant	Rotating machines in the bulk grid
SSR due to negative damping from data center electronics.	Noise/switching operation	<b>Data center power electronics</b>	System series inductance	Series capacitor

### 3.1.1.1 Forced Oscillation Studies

In cases where the data center's load profile is the source of excitation—this is generally a concern for large data centers performing large-scale parallel compute tasks such as training or inference on large AI models—the data center load may be modeled using a user-defined time-varying current or power waveform, constructed using a time-series load profile provided by the data center developer [29]. The Fourier transform can be applied to the load profile to determine the affected frequency range (Figure 17).

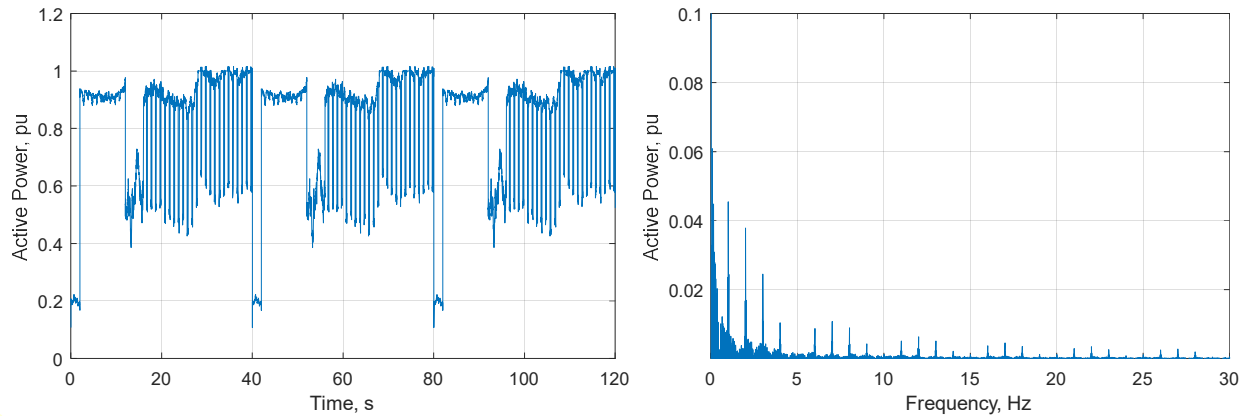

Figure 17: Exemplar Active Power Waveform for AI Training (left) and its frequency spectrum (right).

If there are negligible load fluctuations at frequencies above the bandwidth for which a utility's positive sequence transient stability models are designed, an EMT study is unlikely to yield additional benefits. Positive sequence transient stability models typically capture system dynamics accurately up to several hertz. Thus, EMT modeling is likely unnecessary for studying interactions between data center load fluctuations and electromechanical modes in the 0.1 to 5 Hz range. Rather, the primary reason to perform EMT modeling for forced oscillation studies is to evaluate effects on naturally occurring system modes in the 5 to 60 Hz range. This includes the torsional modes in large turbines, electrical resonances of series-compensated transmission lines, and modes associated with controls in grid-scale power electronics.

So far, EMT studies involving forced oscillations from data centers have primarily focused on the torsional modes of large turbines—the excitation of torsional modes is highly concerning as the torsional modes of gas and steam turbines tend to be very lightly damped, meaning that even a small torque oscillation at the stator terminals can result in a much larger (e.g., 20 to 40 times) torque oscillation between sections of the turbine shaft. The resulting twisting force on the shaft can lead to permanent damage to the shaft (e.g., in the form of permanent deformation and cracking) [30].

While the data center itself is novel as a source of forced oscillations with an unusual signature, practices for EMT modeling of the system and affected generators are mature and available in literature [31] [30] [26] [32]. Broadly speaking, the transmission system may be represented using relatively low-fidelity and most of the model's detail is directed towards the potentially affected component. Current gaps in industry understanding revolve around determining the ability of turbine generators to tolerate oscillatory loads on an ongoing basis [29]. Ultimately, such limits will require input from turbine OEMs, as only they have the design data and modeling tools necessary to determine the operating capabilities of their machines under these new operating conditions.

### 3.1.1.2 Small Signal Stability Studies

In small signal stability studies, the concern is that the data center may contribute a significant quantity<sup>1</sup> of negative damping to an oscillatory mode present in the power system (e.g., one of the last four scenarios described in Table 2). Examples of this include torsional interactions between steam turbines and controls used in LCC HVDC [27] as well as between turbines and and series capacitors [28] [26].

Unlike in a forced oscillation study, modeling the damping introduced by the data center requires a very detailed model—usually one that accounts for OEM- and model-specific variations in power electronics control. EMT analysis is usually used for small signal stability studies that involve oscillation frequencies too high to model accurately in phasor-based tools (e.g., >5 Hz).

The scope and modeling requirements for small signal stability studies can be difficult to define as the range of possible problems is so much greater than the range of problems which are practically relevant. While there do exist methods for system-level evaluation of small signal stability [33] [34], such methods are extremely arduous to scale up to practical power systems, requiring a deep understanding of linear system theory and hundreds of impedance scans. A single impedance scan of a detailed OEM-specific model can take several hours or even days to compute using a typical engineering workstation [35].

To manage the potentially broad scope of EMT small-signal stability studies, engineers often rely on recurring patterns from historical events to identify the need for such studies [36] [37] [24]. Indicators that EMT-based small-signal stability studies should be done include large concentrations of grid-scale power electronics (including HVDC terminals, FACTS devices, IBRs, and hyperscale data centers), series capacitors, and traditional generation [24]. The risk is typically higher when there are multiple such facilities present in a region that is weakly connected to the rest of the grid.

### 3.1.2 Regulation of Voltage and Frequency

While positive-sequence dynamic studies can represent most grid-level impacts that data centers can have on voltage and frequency regulation, there are specific situations where EMT analysis can be a helpful supplement<sup>2</sup>. These situations usually arise when there is a need to establish confidence in the ability of simpler phasor-based models to represent grid-level impacts. Such situations include:

- Characterizing the fault response and ride-through performance of a data center that is based on vendor-specific solutions for achieving ride-through

---

<sup>1</sup>Many common power system components such as generators, motors, and most power supplies introduce some amount of negative damping at the frequencies of existing oscillatory modes. In the majority of cases, such effects are negligible. Because of the significant effort and input data requirements associated with modeling this damping, careful engineering judgment is required when deciding whether to conduct a small signal stability study. The scenarios listed in Table 2 are derived from circumstances known previously to be a source of small-signal stability issues.

<sup>2</sup>Assuming that the EMT model itself is trustworthy, having been verified using experimental data and/or hardware-in-the-loop testing. This fact should by no means be taken for granted but is beyond the scope of this report to address.

- Assessing the performance of data center solutions for providing dynamic voltage or frequency regulation<sup>1</sup>

For mature technologies and applications, where trust in the established phasor models is established, EMT modeling for these purposes is generally unnecessary. However, with data center power electronics evolving so rapidly, both in response to the needs of the grid and of the data centers themselves, significant work is still needed to establish the degree of conformance that data center power electronics have with recently developed phasor models for power electronics [38] [39] [40].

Lessons learned from IBR integration efforts are relevant here [41]—there are numerous instances of unintended vagaries, misapplications, and misunderstandings regarding performance requirements for power electronics which have led to grid disturbances. In other words, even if utilities have set requirements specifying that data centers perform in a way that they can capture using existing phasor models, there are likely to be many instances throughout the adoption phase where these requirements are not met. So long as the component-level power electronic models have undergone the appropriate validation, grid-level EMT studies can identify some of these instances before they result in real-world grid disturbances.

However, once one has confidence that the facilities in question can be adequately represented by the selected positive sequence model (e.g., the PERC1 model [38] [40]), the impacts on grid voltage and frequency regulation from data centers may be studied using phasor-based tools. Example studies include:

- Characterizing impacts to system voltage and frequency for a given data center ride-through characteristic.
- Determining the dynamic VAR margin and voltage stability limits for buses where data centers are connecting.
- Determining resource and frequency balancing resources needed due to data center ramping.

### 3.1.3 Power Quality

Technically, many power quality issues can be modeled using EMT analysis. However, it is often impractical to obtain input data with the quality needed to realize practical benefits over tools such as harmonic load flow software, short-circuit software, or engineering rules of thumb. From the level of grid-level power quality impacts from data centers, harmonics and voltage fluctuations are two important risks to consider [24].

#### Harmonics

Modeling grid impacts from data center harmonics can be broken down into two steps. The first step is the development of the data center's harmonic equivalent, usually given as either a harmonic current source or harmonic Thevenin equivalent. The second step is the evaluation of the voltage distortion produced in the grid. EMT modeling can theoretically be applied at the first

---

<sup>1</sup>A recent subsynchronous oscillation event involving a data center was caused by weak grid conditions and a fast frequency response function present in the UPS [95].

step, but this is not recommended for reasons discussed shortly. EMT modeling is unnecessary for the second step, as a variety of commercial phasor-based programs support harmonic load flow<sup>1</sup> [43].

Serious practical obstacles arise when attempting to collect the data necessary to accurately model the harmonic spectrum of switching-based power electronics commonly used in data centers. Traditional sources of high current distortion (e.g., 30% current total harmonic distortion (THD)) include large diode rectifiers, single phase power supplies without PFC correction, and electronics-based lighting (e.g., fluorescent, sodium, or LED). Data center power electronics usually produce significantly less current distortion. For example, the Open Rack specification for 5 kW rack-level power supplies requires them to produce less than 5% current THD at 30 to 100% of full load [44]. Large double-conversion UPS produce around 3% current THD at full load [45].

The current distortion produced by switching-based power electronics is dictated by factors such as the converter topology (e.g., two-level versus multi-level modular, number of stages, interleaving), controller design and gains, PWM strategy, and parameters which can vary with the specific model of IGBT and/or MOSFET used (e.g., IGBT dead time [46]). These factors can vary significantly with device make and model, and even the data center designer is likely to find the level of modeling necessary to accurately reproduce the current spectrum through simulation to be excessive. Real-world harmonic spectrums obtained from either the field or the equipment OEMs are the most reliable sources of data [43].

Data center developers often develop and utilize standardized designs, and measurements taken from other data centers that are already in service and using similar equipment may be the best option available at the planning stage. Another reasonable approach is to collect sample current spectrums from electronics OEMs and aggregate the results using conservative assumptions (e.g., assume that current harmonics from different loads have the same or similar phase angle<sup>2</sup>).

Harmonic spectrums obtained under constant load conditions are unlikely to be valid for sites with rapid load fluctuations (e.g., due to AI load training). These fluctuations alter the frequency content of the fundamental frequency current component. For example, a 10 Hz fluctuation in active power results in a 10 Hz oscillation in the magnitude of the 60 Hz current waveform. The resulting current waveform has two frequency components—one at 50 Hz and another at 70 Hz. It is reasonable to expect that current harmonics will undergo similar modulations, resulting in a substantially different current spectrum than that obtained under constant load conditions.

Power supply OEMs have been facing challenges from AI training load fluctuations for some time now and have been testing and improving their products accordingly [47] [48] [2]. Thus,

---

<sup>1</sup>Specific utility requirements may not always be consistent with this view [16]. In such cases, follow-on discussions should consider applicable practices and guidance published by consensus-building organizations such as the IEEE, NERC, and E-SIG, all of whom are developing guidance in these areas at the time of writing.

<sup>2</sup>Treating the individual load harmonics as in-phase may be excessively pessimistic. Field experience with harmonic currents injected by IBRs indicates that the aggregate harmonic distortion is roughly the square root of the sum of the squares of individual units [35]. For example, if 1 inverter contributes 1 A of harmonic current, then 100 inverters would contribute 10 A of harmonic current. Similar rules of thumb could apply to data center power electronics.

there may be test data available to help determine the amount of engineering margin necessary to account for fluctuations in current harmonic spectrum caused by rapid load fluctuations.

### **Voltage fluctuations**

As discussed in Section 3.1.1, data center load profiles can exhibit active power variations too rapid for accurate phasor-based modeling, making EMT modeling useful. Depending on the grid strength, these variations can cause rapid fluctuations in the transmission system voltage magnitude. Even at relatively low magnitudes, these fluctuations can cause visual flicker in electric lighting [42]). Flicker-related restrictions are measured at the point of common coupling (PCC) between the customer and utility and require that the voltage magnitude variation be quite small. The most critical aspect is the data center load profile itself, with the grid and facility models being modeled using lumped impedances [49].

Depending on how strict the limits are that utilities establish for oscillations in data center load, flicker considerations may become irrelevant for most interconnections, but requirements in this area are still in their early stages and may or may not be more restrictive than flicker-related requirements.

## **3.2 Suitability of DML Specifically**

In practice, it will seldom be the case that the example systems provided in DML can be used to study real data centers without significant modification. The primary value in DML comes from its potential to accelerate both community understanding of how data centers should be represented in grid-level studies and in the development site-specific EMT models.

Utilities and consultants may find the DML models instructive for understanding the general dynamics of data centers, and for exploring the suitability of various technical solutions for meeting grid requirements relating to ride-through and SSO. Data center developers and OEMs of data center equipment may find these models instructive for understanding which aspects of their highly sophisticated systems are of most importance for grid-level studies, and examples of how their equipment is represented in grid-level studies. DML component models may serve as starting points for OEM- or site-specific EMT models, which many utilities are beginning to request as part of the interconnection process.

## 4.0 Model Overview

This section provides an overview of the models included in the library, including their major design features and intended uses. We focus on explaining the reasoning behind the model design decisions, including both background on data center design and major assumptions. For component-by-component descriptions of the models, refer to Section 6.0.

For precise specifics of how model functions are implemented, users should refer to the accompanying PSCAD files—there is no obfuscation of the model functionality (i.e., there are no black-boxed or encrypted components), and the model schematics have been organized and annotated so that EMT program users can readily interpret the models and adjust them for their own needs.

The DML contains 30 component definitions and 6 simulation files. The component definitions provide modular representations of commonly-used components or functions and are the primary contribution in terms of modeling effort saved for the user. The simulation files are example power systems that demonstrate proper use of the component definitions, primarily by illustrating their use to represent the six archetypical data center designs described in Section 2.0.

Table 3 lists the complete power electronic device models included in the DML and their purpose. In addition to the power electronic hardware, these components contain any additional passive components and control algorithms necessary for the device to be useful for grid-level studies. These are the most sophisticated components in the library, with most of the other components supporting these.

Table 4 lists the control algorithm components provided in the DML. These are mostly commonly employed control elements for power electronics and are used in the complete power electronics device models.

Table 3: Complete Power Electronic Device Models included in the DML.

Model	Definition Name	Purpose
DC-DC Buck-Boost Converter (AVM)	DC_bi_avm	Interface DC devices (e.g., batteries, supercapacitors) with inverters (e.g., UPS) (AVM)
DC-DC Buck-Boost Converter (SWM)	DC_bi_swm	Interface DC devices (e.g., batteries, supercapacitors) with inverters (e.g., UPS) (SWM)
3 PH Inverter, GFL	gfl_ibr	Three-phase inverter with GFL control (e.g., UPS rectifier or grid interface for DC distribution designs) (AVM)
3 PH Inverter, GFM, Droop Control, SWM	gfm_ibr_droop_swm	Three-phase inverter with GFM droop control (e.g., UPS output inverter or grid interface for DC distribution designs) (SWM)
3 PH Inverter, GFM, Droop Control, AVM	gfm_ibr_droop_avm	Three-phase inverter with GFM droop control (e.g., UPS output inverter or grid interface for DC distribution designs) (AVM)
3 PH Set of 1 PH Rectifiers	rect_3x_full_wave	Simplified representation of small motor loads (e.g., fans)
3 PH Set of 1 PH Rectifiers with Protection	rect_3x_full_wave_c	Simplified representation of small motor drive loads (e.g., fans) with built-in voltage protections
3 PH Diode Rectifier	rect_six_pulse	Simplified representation of large motor drive loads (e.g., rooftop chillers)
1 PH Rectifier with PFC, SWM	smps	Grid interface for rack-level power supplies (SWM)
1 PH Rectifier with PFC, AVM	smps_avm	Grid interface for rack-level power supplies (AVM)

Table 4: Control algorithm components included in the DML.

Model	Definition Name	Purpose
GFM Droop Control	gfm_droop	Primary control structure for GFM droop control
$dq$ -Domain current regulator	ireg	Provides current control for inverters with multi-layer controls
$dq$ -Domain Current Limiter	ilim_dq	Provides current limiting for inverters with multi-layer controls
PI Controller with Anti-Windup Logic	PI_AntiWindUp	Improvement over standard PI controller to include anti-windup functions commonly used in inverters
Stabilizer for Droop-Based GFM Control	stage2_ilim	Supplementary control for droop-based GFM control to improve stability during/after faults
$dq$ -Domain Voltage Regulator	v_reg	Provides voltage control for inverters with multi-layer controls
GFM Droop Control	gfm_droop	Primary control structure for GFM droop control

Table 5 lists grid components included in the DML. This includes only two simplified LV cable models, intended to provide reasonable cable representation without the large input data requirement associated with a cable constants routine.

**Table 5: Grid Components Included in the DML.**

Model	Definition Name	Purpose
Lumped LV Cable, 1 PH	LV_cable_1PH	Simplified low-voltage cable model with minimum input data requirements (single phase)
Lumped LV Cable, 3 PH	LV_cable_3PH	Simplified low-voltage cable model with minimum input data requirements (three phase)

Table 6 lists load profile components provided in the DML. These are used to simulate rapid variations in active power demand associated with large-scale parallel computing processes.

**Table 6: Load Profile Components Included in the DML.**

Model	Definition Name	Purpose
Variable AI Training Load	load_ai_train	Highly simplified square-wave model for AI training load, useful for exciting target frequencies
Playback-Based Electronic Load	load_playback	Read in an external active power profile from .csv file, also supports simplified controls for LVRT

Table 7 lists the power electronics hardware components included in the DML. Of all the devices covered by the complete power electronics models (Table 3), the hardware-only component definitions include only the 3 PH inverter models as only these were considered sufficiently complex to merit organization of the hardware into a standalone definition.

**Table 7: Power Electronics Hardware Components Included in the DML.**

Model	Definition Name	Purpose
3 PH Inverter, AVM	VSC_AVM	Hardware for three-phase VSC with optional device-level current limiting (AVM)
3 PH Inverter, SWM	VSC_SWM	Hardware for three-phase VSC with optional device-level current limiting (SWM)

Table 8 lists protection system components included in the DML. These are used to implement various load-level protections that trip off elements of data center load in response to grid disturbances (usually voltage sags).

Table 8: Protection System Components Included in the DML.

Model	Definition Name	Purpose
UPS Controller	ups_ctrl	Centralized controller for UPS to handle protection tripping and transitions between modes
3 PH Contactor	uv_sw	Three-phase contactor with voltage protections
1 PH Contactor	uv_sw_1PH	Single-phase contactor with voltage protections

Table 9 lists signal processing components included in the DML. These implement commonly-used signal processing functions and are used throughout other components and system models in order to improve organization and usability.

Table 9: Signal Processing Components Included in the DML.

Model	Definition Name	Purpose
dq-Domain Power Calculation	PQ_dq	Compute active and reactive power in dq domain
Per-unit Base Calculator	pu_bases	Compute derived bases for convenient per-unitizing
Unbalance Calculation	unb_rms	Compute voltage unbalance per ANSI 47

The following subsections are dedicated to discussing the approach and reasoning behind the selection of these specific component models to represent the variety of equipment present in data centers. For discussion of the site-level design, refer to Section 2.0.

## 4.1 IT Loads

The demand associated with ITE is a majority of data center electricity consumption and may be subdivided into three categories:

1. Compute load, which is dedicated to running processors (e.g., general-purpose central processing units (CPUs), GPUs, or application-specific integrated circuits (ASICs)) which perform a broad range of computationally intensive tasks.
2. Storage load, which is dedicated to storing and retrieving data on non-volatile storage media such as hard drive disks (HDDs), solid-state drives (SSD), and tape storage systems.
3. Communications load, which is dedicated to routing information in, out, and throughout the data center. Common devices include routers and ethernet switches.

Compute load tends to be the dominant source of electricity demand. It is also the most variable with respect to the site's end use (e.g., providing cloud services vs. mining cryptocurrency).

As outlined in Section 2.1, the electrical interface between the ITE and grid can differ substantially depending on the power electronics architecture adopted by the data center. Today, most data centers use Design 2 (centralized UPS) or 3 (distributed UPS), with the

former being more common. As a result, the grid-level dynamics of much data center ITE is determined by the behavior of large 3 PH UPS—these are the focus of the next subsection. In the remaining subsections, we discuss the modeling of the ITE power supplies themselves, the nature of variations in data center power demand that are relevant on an EMT timescale, and the implications of evolving DC distribution architectures (Designs 4, 5, and 6) on grid-level modeling of ITE.

#### 4.1.1 Uninterruptible Power Supplies

Reliability has long been, and in many cases still is, the primary performance requirement for data centers (with energy efficiency and cost being secondary considerations) [5]. Thus, uninterruptible power supplies (UPS) are widely used and, in many cases, may be considered the most significant component when it comes to defining a data center's dynamics from the perspective of a grid-level EMT study. For example, when utilities and data center operators discuss improving data center ride-through, it is often the protection settings and tolerances of the UPS that are the primary focus of technical discussion.

Large data centers usually use large three-phase UPS, which tend to be rated for roughly 1 MVA each and use a double-conversion design (Figure 18):

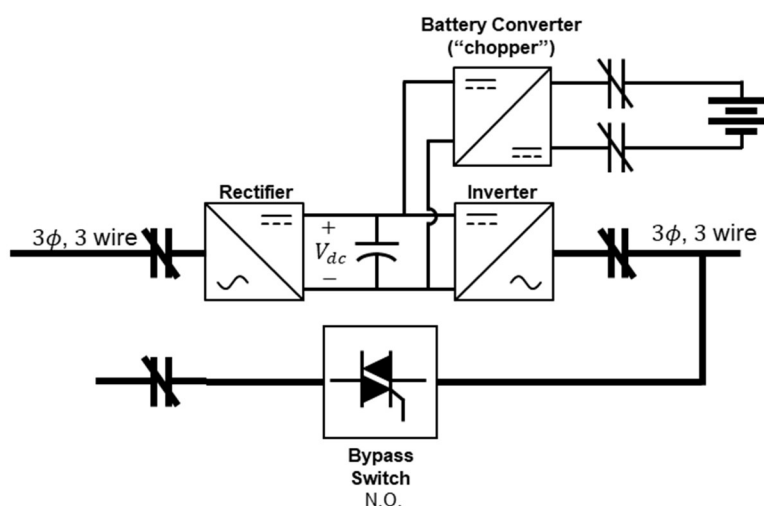

Figure 18: Major Components of Double-Conversion UPS.

The AC output voltage of the UPS is tightly regulated, generally varying in magnitude by less than a few percent even during full load pickups [45] [50]. Consequently, grid disturbances tend to have little influence on the AC output voltage or current, and it is generally unnecessary to model equipment downstream of a double conversion UPS for a grid-level EMT study.

Other well-known UPS technologies include line-interactive or rotary UPS, but these are far less common in large data centers than the double conversion design. Double conversion UPS generally provide the greatest degree of protection for the load (and thus the most significant benefits for site reliability), and improvements in its cost and efficiency over time made it generally the most competitive of the UPS technologies for data center applications.

From a grid perspective, the rectifier and its controls are the most influential in determining the UPS's response to disturbances, although the other two converters also play a significant role during voltage excursions. Rectifiers for the large, three-phase UPS used in data centers are

generally three-phase voltage-source converters; modern designs usually use a three-level converter (either I- or T-type) [51] [5] or a Vienna rectifier [52] [53]. Diode rectifiers are virtually extinct in modern double conversion UPS; they provide neither the efficiency nor the DC link voltage regulation that modern applications demand.

While EMT modeling of existing data centers may consist primarily of double-conversion UPS modeling, this may change in the near future. Attitudes towards reliability in AI data center applications are not necessarily aligned with historical applications, and philosophies are mixed among designers today. Capital costs associated with large data centers are significant (e.g., over \$10B for a 1 GW facility [54]) and backup generation and UPS are a nontrivial component of this cost. As data centers grow larger, they are connecting to higher-voltage substations which experience fewer interruptions and milder voltage sags. Several data center topologies (e.g., designs 3, 4, and 5 in Section 2.1) look to incorporate significant energy storage downstream of UPS. Therefore, the ubiquity of the double-conversion design should not be taken for granted, especially for newer installations.

### Scope of DML Components

In the DML, components for a double-conversion UPS are provided (Figure 19).

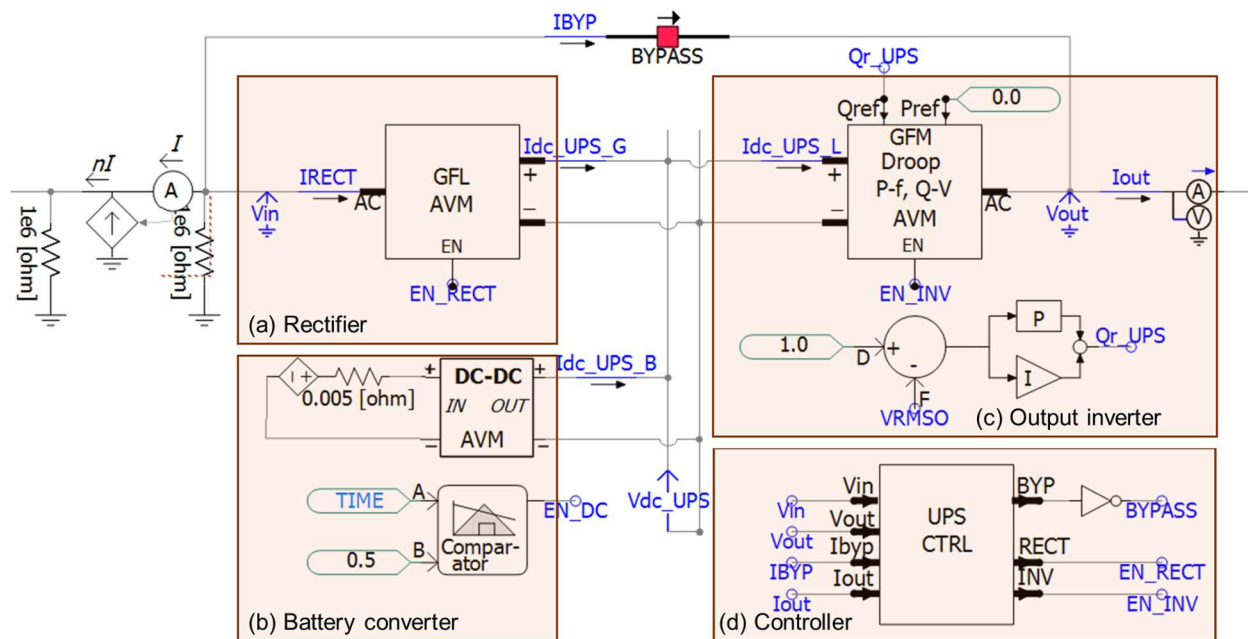

Figure 19: Use of DML Components to Represent 3-Phase Double-Conversion UPS.

The rectifier is represented as an inverter with GFL control (*inv\_gfl*) with controls typical of an inverter configured to provide minimal grid support. It operates at unity power factor and regulates the DC link voltage. A switching model (SWM) for a basic two-level 3 PH inverter is provided (*inv\_swm*), but SWM for more advanced (and common, in the case of large 3 PH UPS) designs such as T-type inverters or Vienna rectifiers are not provided. Such designs use sophisticated switching strategies that, while they enable the higher efficiency these designs provide, have relatively minor impacts on grid-level dynamics. Generic models, such as those provided in the DML, do not offer the precision necessary to capture these impacts—OEM-specific models should be used to address concerns related to specific inverter topologies.

The battery converter is modeled as a bidirectional buck-boost converter (`DC_bi_avm`) and has two control loops—a slow power regulator which represents battery charging control and a fast DC voltage regulator which is designed to rapidly increase the battery output in the event of a small DC link voltage sag. Such a sag indicates that the rectifier has either been tripped offline or hit its current limit (e.g., due to a grid-side voltage sag) and thus the battery converter steps in to avoid any disruption to the load.

The output inverter is represented as a grid forming (GFM) inverter (`inv_gfm_droop_avm`) with droop control. A fast AC voltage regulator is added as an outer loop control to minimize AC voltage magnitude fluctuations during large load changes. A relatively high current limit (1.5 pu) is used, a common design practice which allows the UPS to be used for transformer energization and motor starting [45] [50]. Average-value models are used for all three power converters.

UPS protections and transitions between modes are implemented within a separate UPS controller block (`ups_ctrl`). Basic AC voltage protections are present. The UPS may be started in normal, bypass, or battery backup modes. The UPS load is modeled using an AI training load component (see `load_ai_train` and `load_playback`).

#### 4.1.2 ITE Power Supplies

ITE and the peripherals that support them (e.g., metering and fans) generally accept power at 5 to 50 VDC and so require an AC/DC power supply to interface with the grid. For grid-level EMT studies where power electronics are explicitly modeled, the power supplies for the IT load should be represented if they are directly connected to the grid. This commonly occurs in one of two scenarios:

- 1) There is an upstream UPS which is operating in bypass/eco-mode<sup>1</sup>
- 2) UPS functionality is provided at the rack level (e.g., via a battery connected to the low-voltage DC output from the IT power supply)

If the data center IT load is connected to the grid through a double-conversion UPS, the AC voltage seen by the IT load will be very tightly regulated and the IT load itself can be modeled as a simple current source or passive load.

Technical performance guidelines for data center power supplies are defined under the OpenCompute [55], but a single power supply design is not prescribed. There are a wide variety of single-phase power supply designs used to power IT equipment. At the scale of large data centers, single phase power supplies are rated for several kilowatts each and use some form of PFC, meaning that they produce relatively low levels of current harmonics. Roughly speaking, most power supplies can be represented using the simplified diagram shown in Figure 20.

---

<sup>1</sup>Bypass mode is generally used when an individual UPS is out-of-service for maintenance or repair and so is not represented in an aggregate data center model.

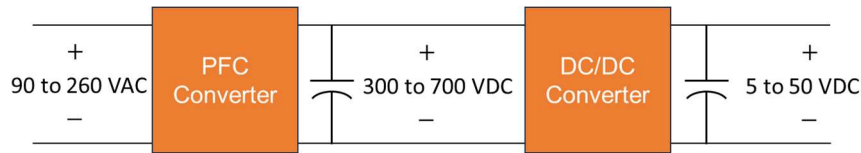

Figure 20: Simplified Power Supply Diagram with Notional Voltage Levels.

The PFC converter converts AC to DC and performs PFC, which, for a power supply, primarily involves reducing harmonic currents. To obtain good efficiency, the PFC converter generally operates in a boosting mode, meaning that the DC voltage must exceed the AC voltage and the DC output voltage is generally several hundred volts. A DC/DC conversion stage is then necessary to significantly reduce this voltage to one suitable for electronics—low power consumption devices such as personal computers generally accept 5 or 12 VDC whereas 48 VDC is used for power-dense racks in data centers. The DC/DC converter also generally provides galvanic isolation (most commonly with a transformer) in order to minimize the coupling of noise from the high voltage stage into the low voltage stage where it may harm downstream electronics.

For the purposes of grid-level studies, representation of the PFC converter is the most important, and representation of the DC/DC converter and other downstream equipment is generally heavily simplified. PFC converter designs can be broadly categorized as either unidirectional or bidirectional. Figure 21 illustrates common variations of unidirectional PFC converters [56]. The conventional design (the leftmost) is seldom used in modern data centers owing to its lower efficiency; the bridgeless and totem-pole designs are essentially two different approaches for reducing the number of semiconductor switches in series.

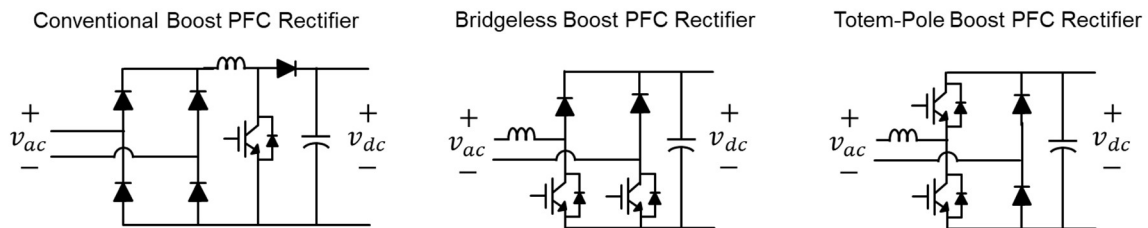

Figure 21: Common Variations of Unidirectional PFC Converters.

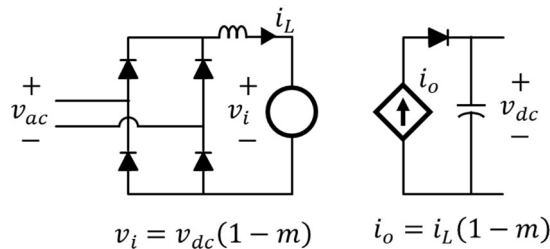

Figure 22: AVM for Unidirectional Boost PFC Rectifiers.

MOSFETs may obtain significantly lower forward voltage drop than diodes (e.g., 0.2 V vs. 0.7 V) and further efficiency improvements are realized by replacing the remaining diodes in the PFC rectifier with MOSFETs, resulting in a single-phase voltage source inverter (Figure 23), which is bidirectional. This approach is popular in high-performance power supplies not because of the bidirectionality or control flexibility but simply due to the efficiency gains. Generally, efficiency is the primary indicator of a power supply’s sophistication and cost, and IT power supplies in large data centers operate at efficiencies in the range of 96 to 99%. Small efficiency gains in this

range are impactful not necessarily due to reduced electricity costs but due to the reduced heating, which allows for higher power density and reliability (e.g., improving efficiency from 96% to 97% corresponds to a 25% reduction in heat produced).

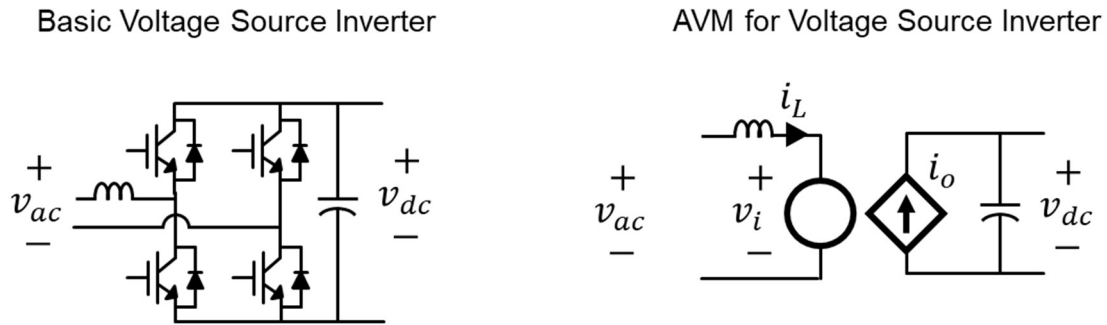

Figure 23: Basic Voltage Source Inverter Topology (Left) and its AVM (Right).

It is common for the two switching legs to use different devices—one leg is optimized to minimize switching losses and performs pulse-width modulation (PWM) while the other is optimized to minimize conduction losses [57]. The latter leg switches only once every half cycle, playing the same role as the diodes in the totem-pole converter. In other words, while the single-phase voltage-source converter (VSC) is capable of four-quadrant operation (and thus a variety of grid support functions), in PFC converter applications it is operated at unity power factor and only consumes active power.

In addition to the basic two-leg design shown in Figure 23, more sophisticated topologies are used to obtain higher efficiency and better power quality (e.g., [58] or [59]). However, for grid-level studies, the conventional average-value model (AVM) for a single phase VSC (Figure 23) may often be used to represent these topologies, and efforts to improve PFC converter model fidelity for grid level studies should focus primarily on representing variations in closed-loop control design, rather than different topologies. The SWM of many modern power supplies are impractical to model in EMT studies as they tend to employ switching frequencies well above 100 kHz. Thus, variations in hardware that do not affect the converter’s AVM are unlikely to be meaningful for grid-level studies.

Further work is needed to investigate the role, if any, that the DC/DC converter models should play in grid-level studies. Two common designs for the DC/DC conversion stage are the high-frequency transformer or LLC converter [60]:

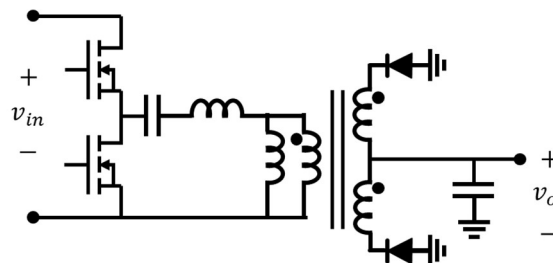

Figure 24: Schematic of Basic LLC Converter.

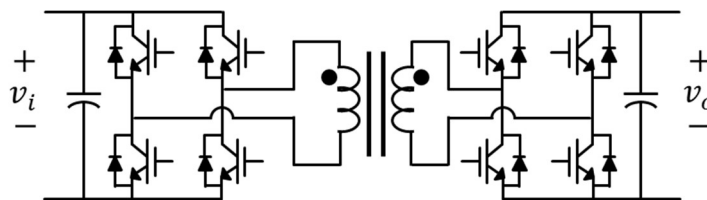

Figure 25: Schematic of High Frequency Transformer for DC-DC conversion.

Both large- and small-signal response of these designs should be investigated. The large signal response is primarily relevant for grid fault studies—if grid faults cause significant fluctuations in the DC/DC converter’s input voltage, the dynamics of the input current should be evaluated. A simple constant current or constant power source with a first-order low-pass filter may suffice. The converter’s small-signal response is primarily relevant for studies of oscillatory interactions, as discussed previously in Section 3.1.1. The importance of the DC/DC converter in such cases should be evaluated by injecting small subsynchronous oscillations at the terminals of the PFC converter and evaluating its small-signal input impedance. If modeling the DC/DC converter dynamics significantly affects the input impedance, then it should be considered in SSCI studies.

As with the PFC converter, there are many multi-stage and interleaved variations of both the high-frequency transformer and LLC converter [61] [62] [63], which permit higher efficiency and power density. It is plausible that these variations will be unimportant for grid-level studies, but some investigation is necessary.

### Scope of DML Components

In the initial release of DML, two single-phase power supply models are included:

1. A conventional PFC boost rectifier SWM (`pfc_swm`)
2. A PFC boost rectifier AVM, which represents an AVM for a variety of unidirectional PFC converters (e.g., those three shown in Figure 21) (`pfc_avm`).

These models were developed based on models of power supplies of cryptomining hardware [64], which also now publicly available [65].

Inclusion of a single-phase inverter model is a priority for the next round of development—the single-phase inverter design is particularly useful for studying solutions for improving grid stability, as it is far more capable of providing grid support functions (e.g., fault ride-through or dynamic reactive power support) than the unidirectional designs. The SWMs—items (1) and (3) above—are included primarily to allow for validation against the corresponding AVMs. In the interim period, users may consider the basic 1 PH inverter model provided by Manitoba Hydro as a starting point [66].

While there are a wide variety of hardware topologies and PWM switching strategies for both unidirectional and bidirectional PFC converters [67] [59]. Most such variations have little influence on the power supply’s AVM, and the SWMs included with the library are included to serve as benchmarks for the AVMs—the AVMs should be used for grid-level studies as they allow for a much larger simulation timestep (50  $\mu$ s vs. 5  $\mu$ s). Notably, harmonic studies are an exception to this guideline. Variations in hardware topology and modulation strategy are massively influential on the power supply’s harmonic spectrum, but so are factors which are

impractical to include in grid-level EMT models, such as the specific MOSFET selected by the OEM. Harmonic spectrums for power supplies should be obtained through testing, field measurements, and/or support from the OEM, rather than through EMT modeling.

### 4.1.3 Short-Time Load Profiles

In this section, we discuss the causes and nature of rapid load fluctuations in data centers which can be relevant for EMT studies. This context will help DML users to create more realistic scenarios with their models—DML components have built-in functions to represent many of the data center behaviors discussed here.

The active power demand of some aggregate ITE can vary significantly on a timescale relevant to EMT studies (i.e., it can vary quite rapidly). This makes it necessary to apply a time-varying load to the IT power supply model for certain kinds of data centers. Most data center ITE operates at very nearly unity displacement power factor, and most reactive power flow arises from balance of plant equipment such as transformers, harmonic filters, and shunt capacitors.

Until the past few years, data center loads have been generally regarded by grid operators as stable, smooth, and dependable [68] [69]. While electronic power supplies and UPS have both long been capable of quickly ramping, the sheer variety of sectors and applications making use of data center services resulted in the individual compute, storage, and communications loads within most data centers being highly uncorrelated with one another or even factors which most types of load covary with significantly, such as the time of day or week. The result is very consistent electricity demand, with no meaningful fluctuation on the timescales associated with EMT modeling. Three factors have contributed to a shift in this view:

1. Cryptomining
2. Increased scrutiny over data center tripping
3. Hyperscale parallel computing processes

#### Short-Time Demand Variations from Cryptomining Demand Response

In the case of cryptomining, short-time load variations are driven by fluctuations in the price of electricity and electricity incentives, which can comprise a significant fraction of the facility's total revenue in some markets [70]. In the absence of ramping requirements, large cryptomining facilities may significantly vary their load in response to changes in power market conditions [71]. Traditional data center business models heavily prioritize reliability and uptime—they seldom participate in demand response programs.

#### Short-Time Demand Variations from Data Center Tripping

Traditional data center applications are not known for quickly ramping online or rapidly varying their workload; minimizing risk to site processes is a major priority in how the data center is operated and transitions back to grid power are handled carefully. However, in recent years, both traditional data centers and cryptominers have come under scrutiny for their tendency to disconnect in response to brief voltage sags [72] [73] [74]. The systemic nature of this behavior at these facilities has resulted in unexpected gigawatt-scale load drops and effects measurable at the interconnection level.

The ride-through behavior of a facility’s ITE (the majority of its load) is driven by three factors, the applicability of which depends on the design of the site’s protection system

1. Site-level undervoltage protections, potentially implemented in protective relays installed at the HV, MV, or LV levels. These may be part of automatic transfer schemes that control separation from the utility and the transfer to on-site generation.
2. Protections within rack-level power supplies: During a grid-side voltage sag, the response of most PFC converter controls will be to consume additional current in order to maintain the DC bus voltage (i.e., the power supply exhibits a constant power characteristic). There is usually overcurrent protection present so that, if the current increase is excessive, the PFC converter is tripped offline. However, the PFC converter may have a current limiting control, in which case the converter reverts to constant current behavior for deep voltage sags. The DC bus voltage will then decline over time, as the converter is no longer drawing sufficient power from the grid to offset the energy consumed by the load. In this case, the PFC converter may eventually trip on DC bus undervoltage. Some PFC converters use AC undervoltage protection as well. Figure 26 illustrates one potential response of a PFC converter to an AC voltage sag, with annotations indicating elements of the PFC response that may trip protection functions.

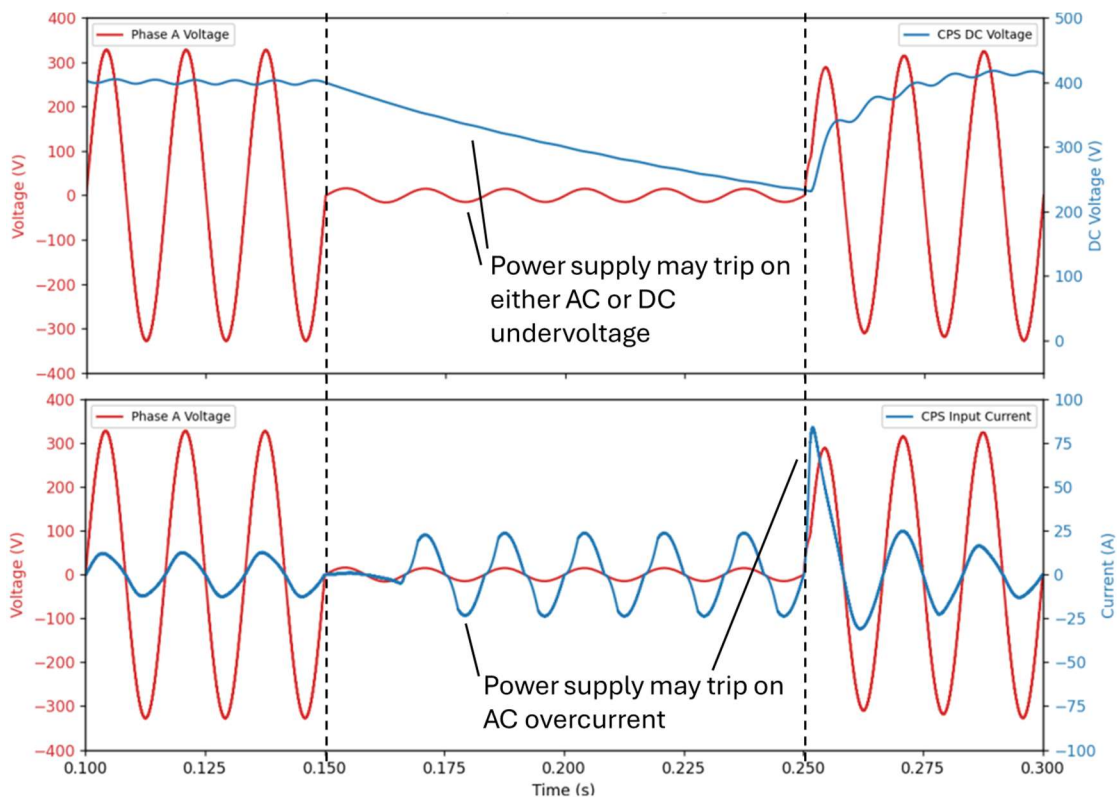

Figure 26: Example Response of PFC Converter (Called the “CPS” in the Figure Legend) to Severe AC Voltage Sag [75]. Annotations Indicate Features Which May Cause Protection Functions to Operate.

With rack-level energy storage becoming increasingly common for data centers (see designs 3—6 in Section 2.1), there are opportunities for this ride-through behavior to be improved without hardware changes. Rack-level storage can be used to supply energy

to the DC link capacitor during AC voltage sags, eliminating the DC undervoltage and AC overcurrent.

3. **Protections within UPS:** If the ITE is protected by double-conversion UPS, the factors in (2) do not apply, and it is the protection settings of the UPS that control ITE ride-through. Modern UPS rectifiers invariably possess AC current limiting control, and the battery converter is designed to provide additional energy to support the DC link voltage when the rectifier is in its current limiting mode. For many excursions in grid voltage, the UPS battery can adequately regulate the DC link voltage and prevent any adverse impact to the downstream load.

Figure 27 illustrates the simulated response of a double-conversion UPS riding through a severe three-phase fault occurring at  $t = 2$  s and cleared at  $t = 2.1$  s. In response to the voltage sag, the input current increases in an attempt to maintain a constant DC link voltage (and, as a result, a constant input power), but the current limit is rapidly reached. The battery output current rapidly increases to provide the DC link voltage with additional support, and the resultant effects on the output current and voltage are negligible.

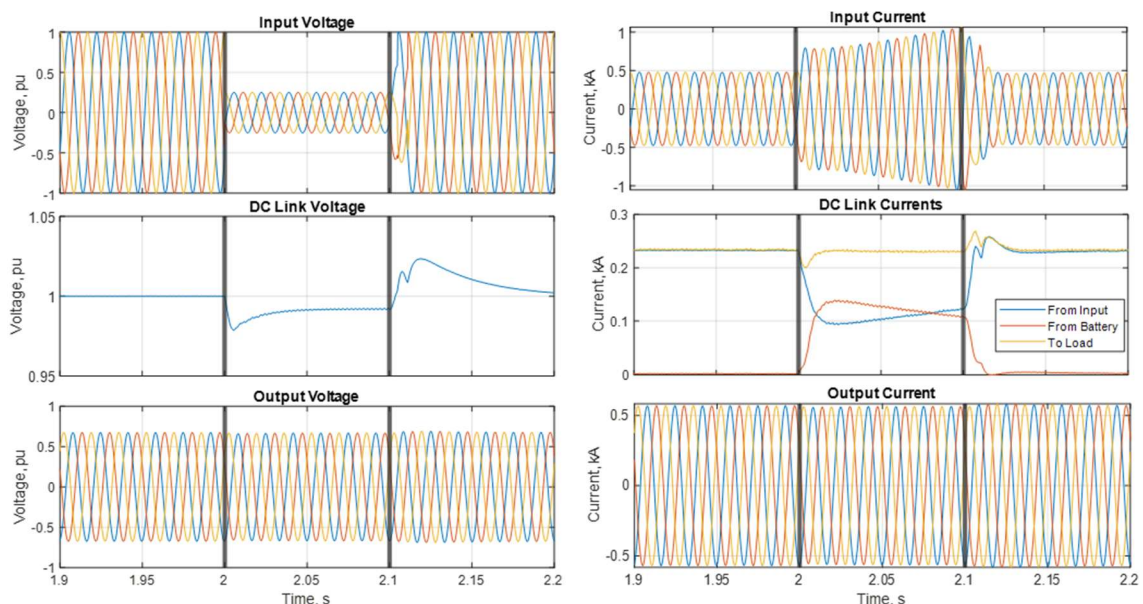

Figure 27: Simulated response of double-conversion UPS configured to ride-through a severe three-phase fault [75].

In reality, few UPS would ride through the fault illustrated in Figure 27. Because data center ride-through has become important only recently, most existing UPS protections are set conservatively (i.e., they trip quickly and for shallow voltage sags) so as to minimize the risk of damage or malfunction in either the UPS or downstream equipment. However, as data center owners have become more aware of ride-through impacts, UPS OEMs have been revisiting their stated ratings and developing new firmware features to permit a greater degree of ride through (i.e., they remain connected to the grid for more significant voltage excursions and for a longer period of time).

Ultimately, the low voltage ride through (LVRT) performance of the UPS is then determined by its ability to limit rectifier current during abnormal voltage conditions, maintain synchronism with the grid, and maintain tight regulation of the output inverter's

AC voltage. OEMs specify LVRT limits for their UPS based on the performance of their controls in these respects, but more restrictive limits can (and often are) implemented in the UPS protection—these vary from site-to-site and may be set by users. If the UPS is operating in eco-mode/bypass prior to an LVRT event, the UPS must rapidly trip the bypass switch (likely on a sensitive AC undervoltage protection) and transfer the load to the rectifier, with the battery converter providing DC link voltage support as needed.

At the time of writing, technical restrictions and site practices surrounding the ride-through capabilities of cooling load have yet to converge to a clear trend. Because most data center electricity demand comes from ITE, existing efforts have prioritized improving the ride-through of ITE before devoting significant efforts to the cooling loads. Many motor drives can be configured to achieve good ride-through performance with the proper controls [76], However, the drives themselves are only one component of the cooling system.

The cooling systems of large data centers are complex systems, with many motors, sensors, controllers, actuators, etc. coupled to the same mechanical process. If even one of these devices malfunctions in response to a voltage sag, the entire cooling process may malfunction. Thus, it is a common practice to restart the entire cooling system in response to voltage sags, which requires the temporary disconnection of all cooling load. Depending on the thermal system's design and the data center's tolerance for risk, the entire site may need to be disconnected in order to ensure subsequent recovery activities are not disrupted by any additional grid disturbances. There are a wide variety of cooling system designs in use today [5], and data center cooling is the focus of intense research and development [77], primarily in response to the significant increases in heat density associated with near-future AI platforms.

### **Short-Time Demand Variations from AI Training and Inference**

It is common for the power consumption of individual processors to vary quite rapidly on a millisecond timescale when performing intensive tasks. For most computing tasks, these variations tend to cancel one another out and the data center's site-level demand is quite smooth. In the case of parallel computing processes, however, the rapid variations in processor-level power consumption become correlated. As a result, the variations become significant at the site level. At the time of writing, this phenomenon is almost solely attributed to the training and inference processes of large AI models. Because much of AI training follows the same basic structure, AI training waveforms have a very distinct signature. Figure 28 illustrates an example active power consumption waveform for training a large AI model. Each of the indicated time periods correspond to a specific stage of the training process.

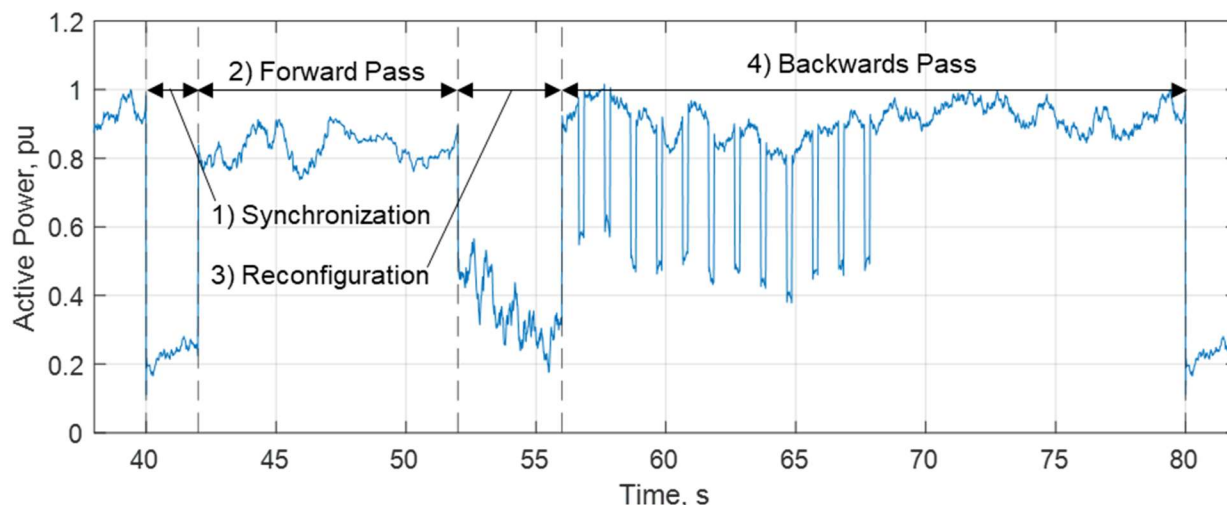

Figure 28: Exemplar Site-Level Active Power Consumption from AI Training Load, Annotations Demarcate Distinct Stages in the Training Process.

Generally speaking, the high power demand periods shown in Figure 28 correspond to computation-focused time periods whereas low-demand periods correspond to storage and communication-focused time periods. There are a variety of techniques for dispatching compute jobs to individual processors, but synchronous operation of site processors in this way is critical to obtaining good training performance [78] [79].

Many AI training iterations can be organized into the four stages shown in Figure 28:

- 1) Synchronization: Compute loads are inactive and ITE energy consumption is low—data transfers and synchronization processes are underway to prepare for the forward pass.
- 2) Forward propagation: Compute loads are active, and ITE energy consumption is high.
- 3) Loss function computation and reconfiguration: Some compute loads are active intermittently, power consumption tends to be moderate and choppy.
- 4) Backward propagation, parameter adjustment: high power consumption, rapidly drop off to low load afterwards.

Backward propagation usually takes roughly twice the time forward does [79] [24] [80]. The duration for a single round of training can vary widely but is on the scale of tens of seconds for a large model at a hyperscale facility.

The brief drops in consumption included in the first half of the reverse pass ( $t = 56$  to  $68$  s in Figure 28) have been anecdotally observed in published waveforms [79] [24] [80] but may occur either at other times in the training process as well or not at all. These could depict a specific style of parallelization and indicate a time period where more frequent data exchange between individual processors is necessary.

#### 4.1.4 Implications of DC Distribution

In section 2.1, we introduced three near-future data center concepts where the IT loads are supplied via a DC distribution, operating first at low voltage (e.g., 400 or 800 VDC) and then medium voltage (e.g., 20 kVDC). In all cases, there is a need for a high-power, three-phase AC/DC conversion stage interfaced with the grid. The application needs are similar to those of three-phase double conversion UPS, and a three-phase voltage source converter based on Si IGBTs or SiC MOSFETs is a likely candidate. Controls for such a converter could plausibly be designed to meet performance requirements such as those given in IEEE 2800 [18].

In the library's alpha release, data centers with DC distribution have been modeled much like UPS-based data centers—the UPS output inverter is replaced by a DC/DC converter which in turn serves IT load. To manage the technical scope of the DML's initial release, a basic buck-boost DC-DC converter is used (`DC_bi_avm`). Further representation of the DC system will require the development of additional models to represent LLC converters, high frequency transformers, and solid-state transformers.

Developing EMT models for these more realistic DC/DC step-down converter concepts should be a priority for follow-on EMT model development. Further consideration should also be given to neutral-point clamped (NPC) converter and multi-level modular converter (MMC) VSC, which are more practical for medium-voltage AC/DC conversion but introduce additional balancing controls. It is possible that the dynamics of these balancing controls will be unimportant for grid level studies, even during grid disturbances such as faults. However, further investigation is required to confirm this.

## 4.2 Climate Control Loads

Most of the energy consumed by IT loads is dissipated as heat, and thus a significant fraction of total data center electricity consumption (10 to 40%) can come from climate control loads. Variance in cooling load primarily comes from climate and the extent to which energy-efficient building design [81] is employed (e.g., computational fluid dynamics to optimize air flow, air-side economization, water-side economization, hot/cold aisle containment). In terms of electrical equipment, these are predominantly small- or medium-sized fans and pumps driven by induction motors. These are used to:

- Humidify or dehumidify incoming air.
- Pump chilled water for facility-level air conditioning (part of the compute rack air conditioning (CRAC)).
- Move air across air conditioning radiators.
- Circulate air in compute rooms (this is a major source, the compute rack air handling (CRAH)).
- Pump coolant for rack-level liquid cooling solutions.

Rack-level liquid cooling is primarily used when compute load largely consists of AI training hardware (e.g., the NVIDIA GB200 platform [82]) as it is made necessary by the hardware's exceptionally high power density. Fan cooling done at the device or rack level is usually

powered via low-voltage DC and is, from the perspective of grid-level modeling, effectively part of the compute load.

Humidity control and its role in data center electricity and water consumption has declined significantly over time, as it was formerly commonly believed that low humidities introduced significant risks to electronic devices by increasing the likelihood of damage from electrostatic discharge (ESD) [5]. Today, relative humidities down to 8% are often accepted.

Dehumidification is still necessary in humid climates—common air pollutants form corrosive compounds at relative humidities above 60%, and data center humidities are kept below this threshold, even if such air pollutants are thoroughly filtered out before entering the data center.

Local climate and the data center developer's energy efficiency philosophy are the two driving factors for cooling load energy consumption. Cooler climates require air conditioning units to run less often and permit the use of air economization methods which greatly reduce overall cooling load. Data center efficiency is usually summarized in terms of power usage effectiveness (PUE), which represents the total facility energy consumption divided by the energy consumed by IT equipment. Thus, a lower PUE is better and 1 is the lowest possible PUE. Notionally speaking, a data center in a warm, humid climate might operate at a PUE near 1.4 or 1.6 whereas a data center in a cool, temperate climate might operate at 1.2. There are not strictly enforced guidelines for how PUE is measured and reported—comparing PUE across different facilities as a measure of energy efficiency performance is often misleading.

Managing data hall air flow is a critical aspect of cooling system energy consumption; suboptimal designs result in hotspots which are resolved in the field by lowering overall cooling setpoints. Optimizing air flow requires rigid design standardization and the use of computational fluid dynamics (CFD) modeling [5], making it more suitable for large scale and/or vertically integrated sites, as opposed to sites with a variety of tenants and equipment that changes on a regular basis.

Most data center pump and building-level fan loads are three-phase induction motors driven by variable-frequency drives (VFDs) [5], as opposed to motors directly connected to grid power. VFDs are increasingly common, even in residential appliances, and they are particularly attractive for data center applications for their ability to improve overall cooling system reliability and efficiency due to the improved control they provide over motor speed. The prevalence of VFDs in data centers has important implications for power system modeling—the dynamics of the cooling load will be primarily determined by the characteristics of the VFD's power electronic front end, rather than those of the induction motor and associated mechanical load.

Front-end power electronics for small (i.e., several HP or less) VFDs are usually either diode rectifiers or voltage-source converters (VSC), which respond very differently to grid disturbances. Diode rectifiers are much more common due to their lower cost and higher efficiency—the primary benefit of using a VSC over a diode rectifier for a VFD front end is the reduction in current harmonics and is, in some circumstances, a cost-effective option for complying with IEEE 519 harmonic limits [83] (most utilities require compliance with these limits as part of the interconnection agreement). Given the small size of the individual cooling loads in data centers, we assume that data center designers typically employ more common approaches for harmonic control (e.g., passive components such as shunt filters and series reactors), and the data center VFD models use diode rectifier front ends.

## Scope of DML Components

The DML contains components for relatively simplistic representation of cooling loads. Both single- and three-phase rectifier models (`rect_3x_full_wave`, `rec_six_pulse`) are provided, with the drive inverter and induction motor represented using a simple resistance.

While a more complete representation of the output inverter and motor may better represent the response of the DC link voltage to grid disturbances, such results may be misleading when evaluating undervoltage ride-through. Large data centers often use a centralized chilled water plant and large rooftop chillers, both of which require that many electrically-powered devices (valves, control circuits, motor drives, etc.) be coupled to the same mechanical process. Even if only one or two of the devices connected to the same mechanical processes malfunctions or resets during a voltage sag, this can result in improper operation of the entire cooling system. Thus, undervoltage drop-outs with either manual or automatic restarts are commonly employed—even if it appears that the drive load itself can ride-through without disruption, there are numerous control circuits which, while impractical to explicitly represent in grid-level EMT studies, may nevertheless define the LVRT capability of climate control processes.

### 4.3 Site Support Load

Site support load encompasses any load that does not fall into the category of climate control or IT equipment load and is generally a small portion (<10%) of the total site load. In addition to lighting, this includes small appliances and electronics typical of an office space environment. For grid-level studies, the dynamics of site support loads are generally assumed to be negligible and they are modeled as constant impedance loads.

#### 4.3.1 Balance of Plant

The balance of plant (BoP) equipment included in the library represents a minimum of the on-site distribution system necessary to study how the aggregated load devices will respond to grid disturbances. As seen in Section 2.1, this mostly consists of aggregate representation of power transformers and cables. The intent is to provide a reasonable representation of the series impedance between major elements in the plant and the grid up to a frequency of several hundred Hertz.

## Scope of DML Components

The only new components for BoP modeling introduced by the DML are low-voltage cable models (`LV_cable_1PH`, `LV_cable_3PH`) intended to provide the user with a convenient tool for approximating aggregate LV cable impedance without needing to collect a large quantity of data for use in a cable constants routine.

#### 4.3.2 Energy Storage Systems

Energy storage systems (ESS) are an essential part of most data centers. The traditional role of ESS has primarily been to support critical cooling and IT load during grid power outages for the short time (e.g., 10 minutes) necessary to bring backup generation online and gracefully transfer the load. However, as data centers grow in size, are subject to LVRT requirements, and serve massive parallel computing processes, the role of energy storage in data centers is rapidly expanding.

Most ESS being considered or installed in data centers are either battery ESS (BESS) or supercapacitor ESS (CESS), meaning that they generally operate using DC and require a power converter to connect to the grid (either DC/AC or DC/DC, depending on whether the grid uses AC or DC). For grid-scale applications, the primary advantages of supercapacitor technology over Lithium-ion battery technology are its low maintenance requirement and tolerance of repeated cycling [84]. Supercapacitors can generally be sized to provide energy for tens of seconds whereas lithium-ion battery systems can supply energy for several hours. Supercapacitor and battery (primarily lithium ion) technologies are current subjects of significant research and development effort and market investment, and the performance and economics of these solutions may evolve significantly in the coming years.

Figure 29 illustrates five commonly considered ESS products and the points in the data center architecture they may be integrated. A simplified version of the centralized UPS architecture has been used here for the purpose of illustration—the ESS connection points identified are present in the near future data center designs as well.

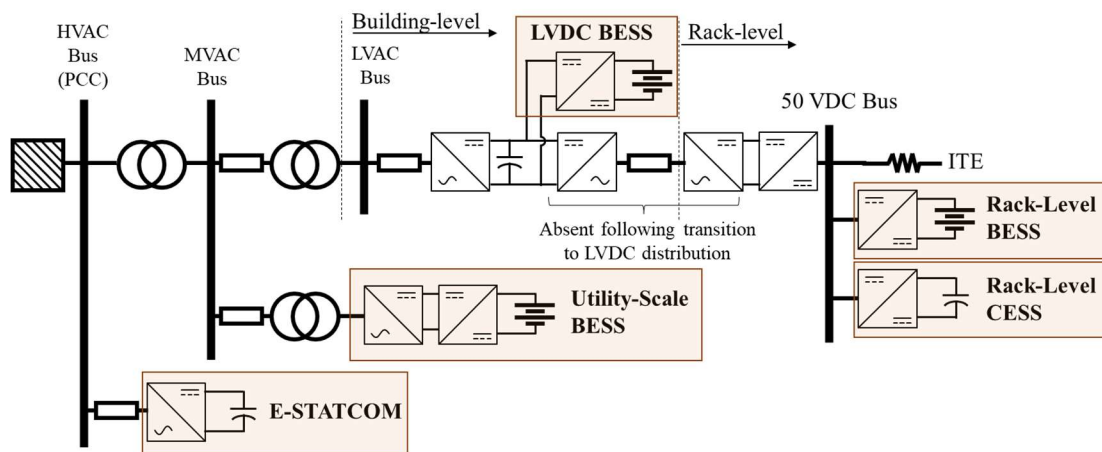

Figure 29: Five ESS Deployment Points for Modern and Near-Future Data Centers.

Both E-STATCOMs and utility-scale BESS have not traditionally been located with data centers but are currently marketed as near-term solutions for grid impacts from sudden variations in data center demand. An E-STATCOM is a relatively new kind of static synchronous compensator (STATCOM). STATCOMs are large 3 PH inverters that do not have any load or generation connected to their DC link [85]. STATCOMs are used to provide dynamic reactive power support to enhance power system stability. An E-STATCOM differs from the traditional STATCOM in that it uses supercapacitors to obtain a very high DC link capacitance, allowing it to provide active power support as well, albeit for a short time period (e.g., 10s of seconds).

Differences in construction between E-STATCOMs and utility-scale BESS have important implications for the modeling of AI load smoothing applications. E-STATCOMs are often implemented using a single 3 PH inverter based on multi-level modular converter (MMC) technology [85]. This allows a single converter to achieve very high power (e.g., >100 MVA) and voltage (e.g., up to 750 kV) ratings. Utility-scale BESS, on the other hand, often use a large number of medium-power (e.g., 1 MVA), low-voltage (e.g., 480 VAC) 3 PH inverters [86]. As a result, the BESS requires a centralized plant controller which necessarily offers lower control bandwidth than the controls used for a single large inverter. Thus, E-STATCOM products can achieve significantly greater attenuation of active power oscillations than BESS (e.g., >95% vs. 70%) [85]. This is the result of the inverter architecture used, as opposed to any difference

between supercapacitor and battery technology. The absence of an MMC-based BESS product in the market today is more likely the result of market forces, as opposed to a technical limit.

Both the E-STATCOM and utility-scale BESS seek to manage data center power fluctuations after they have already entered the AC power system. However, smoothing rapid power fluctuations is generally easier to accomplish in the DC portion of the system—there is no need to deal with frequency, phase, or reactive power, and simpler control approaches can be used. Site level power density, energy efficiency, and cost can all be improved by integrating the ESS more closely with the power electronics already existing in the data center. Near future data center design concepts seek to implement a mix of LVDC BESS, rack-level BESS, and CESS [10] [9]. These approaches may replace AC-interfaced solutions in the near future.

The LVDC BESS, as depicted in Figure 29, could correspond either to the BESS that have long been used in double-conversion UPS or a standalone device used as part of a future data center with a DC distribution system. The DC bus it connects to could either be internal to a double-conversion UPS or part of an LVDC distribution system. From a modeling perspective, the essential design feature is that the BESS is integrated at the LVDC level through a DC-DC converter with an output voltage of several hundred volts DC.

The LVDC BESS used in UPS today have two important limitations which can drive the need for an E-STATCOM or utility-scale BESS even at sites where there is significant UPS capacity installed:

1. UPS batteries are often sized to supply energy for tens of minutes. Batteries of this size will quickly wear out their useful life if used for continuous load smoothing.
2. The UPS rectifier may need to trip offline during a grid disturbance in order to ensure the disturbance does not impact the protected load. The critical implication here is that the ITE cannot remain connected to the grid in this case and a utility-scale BESS or E-STATCOM may be necessary in order to meet ride-through requirements

Rack-level BESS are primarily used to provide UPS functionality in distributed UPS architectures—in such designs there is no double-conversion UPS and thus battery backup must be implemented directly at the 50 VDC level. Within the Open Rack project, rack-level BESS are known as battery backup units (BBU) [87].

Rack-level CESS are used to provide demand smoothing at the rack level—rack-level BESS are sized to supply load for only several minutes and, like the LVDC BESS, will quickly age if used for load smoothing. Rack-level CESS are newly arrived to market and Open Rack specifications for their performance are not yet released.

### **Scope of DML Components**

In the initial release of the DML, limited functionality is provided for representation of ESS that are not specific to data centers (E-STATCOMs or utility-scale ESS), but the power conversion technologies involved are similar enough to data center electronics that some representation is possible.

Built-in PSCAD components for batteries or capacitors may be used for the energy storage elements themselves. Alternatively, because battery state of charge (SOC) does not generally

vary significantly during the time period of an EMT simulation, a DC voltage source and resistance may be used to represent the battery.

The AC/DC converter used in utility scale BESS can be represented using the `inv_gfm_droop_avm` component, which will naturally provide some level of oscillation suppression depending on the control gains and grid impedances used. That said, the model does not include functions specific to oscillation suppression or for replacing the active power consumption of site load that tripped in response to a grid disturbance.

The DML does not include models for controls specific to E-STATCOMs.

The DC/DC converter used in LVDC ESS, rack-level BESS, and rack-level CESS may be represented using the `DC_bi_AVM` component.

## 5.0 Power System Models

In this section, simulation results obtained using the DML models and case files are presented to demonstrate the model's behavior and potential use cases. DML contains simulation files (.psc format) which represent different power system models for simulations. The simulation files include the generic data center designs introduced in Section 2.0, as well as some benchmark cases useful for illustrating grid-data center interactions or testing out the more complicated models.

**NOTE:** The parameters used in these models (cable impedances, protection setpoints, controller gains, etc.) are intended to be reasonable and illustrative, but they are not based on comprehensive surveys and can vary significantly site-by-site. The provided parameters are meant to provide users with a functional and reasonable model, but may not be representative of typical parameters at real sites.

### 5.1 Inverter Model Demonstration (DML\_Inverter\_Demo)

The DML\_Inverter\_Demo model (Figure 30) is a simple test system for 3 PH inverter models such as `inv_gfl` and `inv_gfm_droop_avm`. It contains two copies of the same basic transmission system (a) in order to facilitate convenient comparison of any two 3PH inverter models (b). For 3 PH inverters that perform DC voltage regulation, the DC side should be modeled as a current source (c)—otherwise, a voltage source should be used. The DC current source model includes a basic momentary cessation function (d), which is necessary to avoid DC voltage instability during close-in faults.

Figure 31 illustrates the PCC voltage and current obtained for a line-to-line (L-L) transmission system fault using both `inv_gfm_droop_avm` and `inv_gfm_droop_swm`, illustrating the similarity of the two models' low frequency behavior.

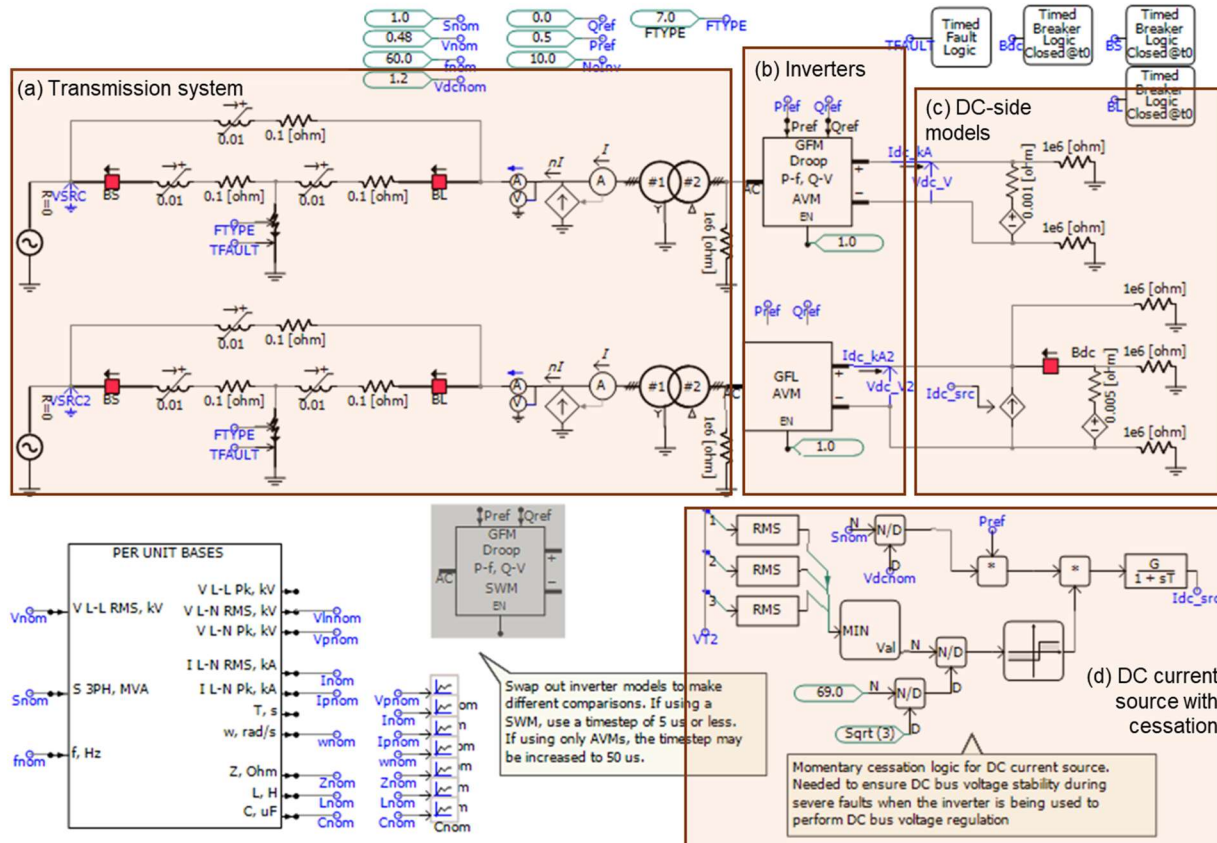

Figure 30: Overview of DML\_Inverter\_Demo Model.

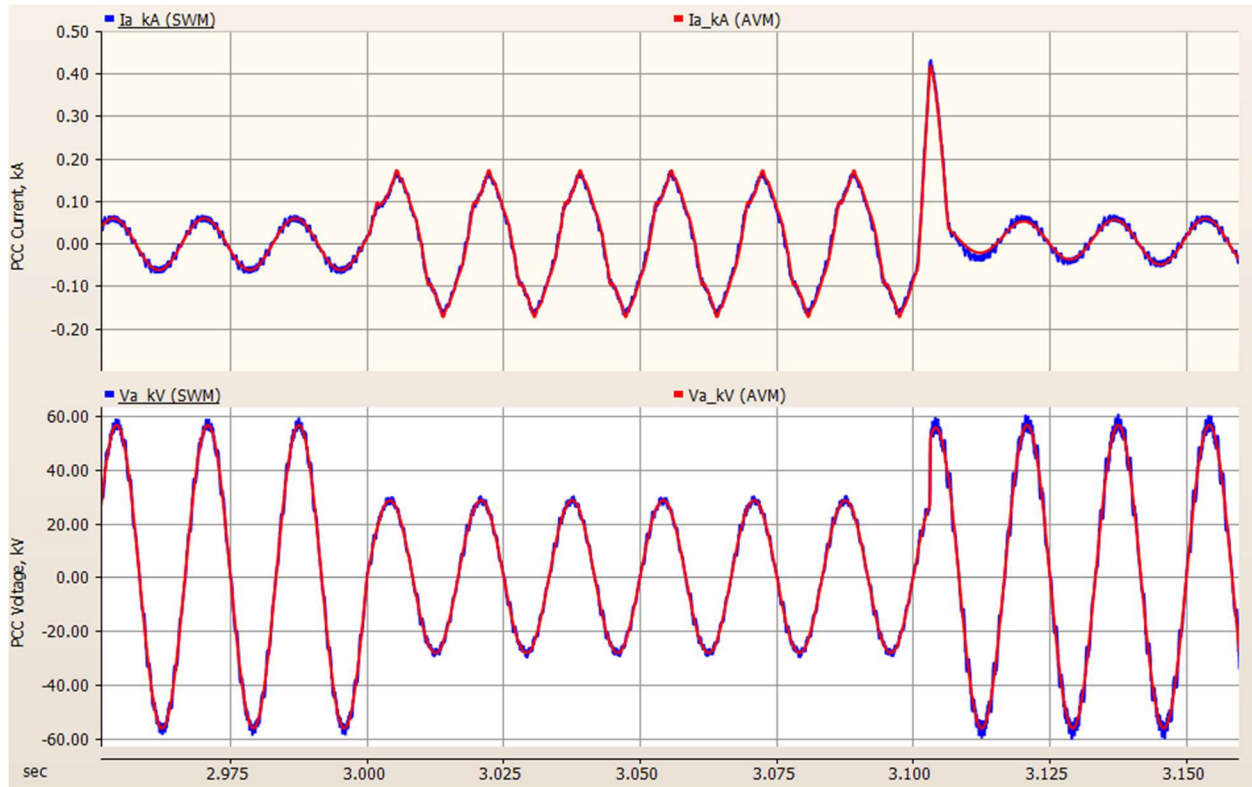

Figure 31: Comparison of L-L Fault Response from `inv_gfm_droop_avm` and `inv_gfm_droop_swm`.

## 5.2 DC-DC Converter Demonstration (DML\_DC\_DC\_Demo)

The `DML_DC_DC_Demo` model (Figure 32) is a test system for DC-DC converter models, `DC_bi_avm` and `DC_bi_swm`. A timestep of  $5\ \mu\text{s}$  should be used if the SWM is used. However, if the SWM is disabled, the model timestep can be increased to  $50\ \mu\text{s}$ . The transmission system model is identical to that used in the `DML_Inverter_Demo` model.

Figure 33 compares the response of the SWM and AVM DC link voltage (top) and current (bottom) for a L-L transmission system fault. Observe that there are small but noticeable differences between the model. This is because the losses of the DC-DC converter, which are imperfectly approximated in an AVM, play a significant role in determining its transient response. This is in contrast with the case of the 3 PH inverter (refer back to Figure 31), wherein this differences in losses has a negligible influence on the inverter dynamics and the SWM and AVM are more or less identical for the purpose of grid-level studies.

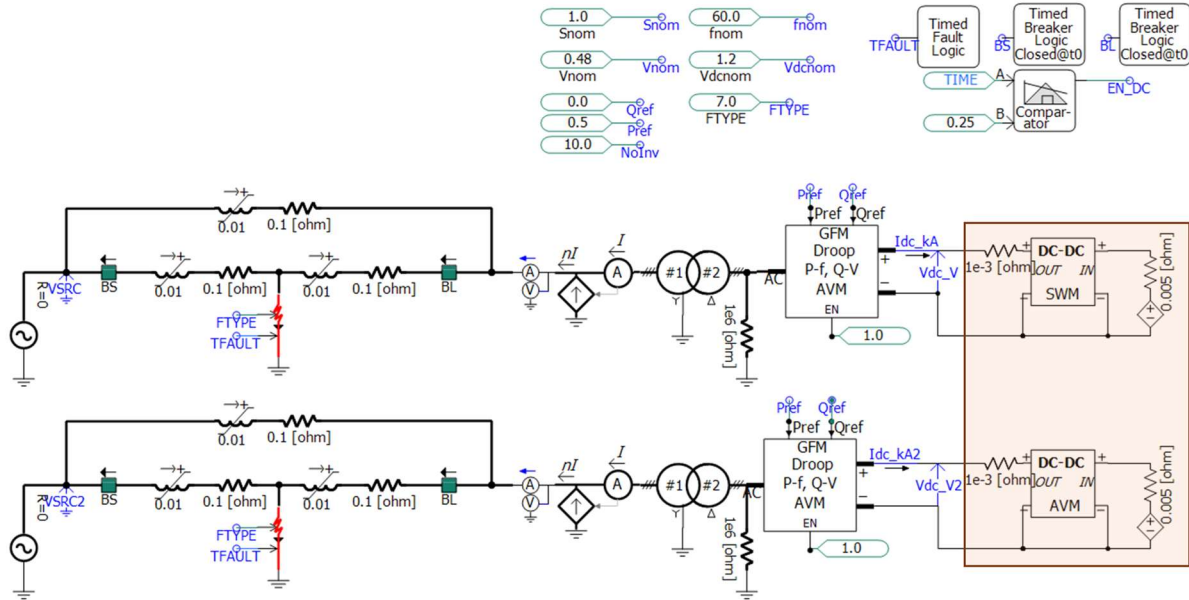

Figure 32: Overview of DML\_DC\_DC\_Demo Model.

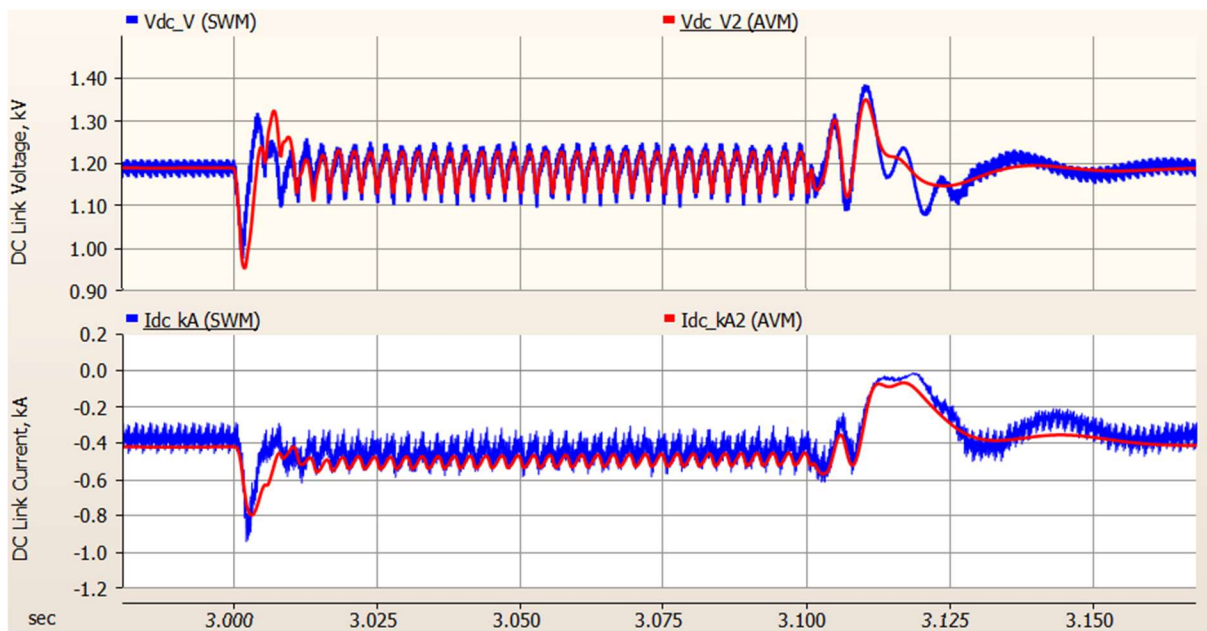

Figure 33: Comparison of SWM (Blue) and AVM (Red) Response to Transmission System L-L Fault.

### 5.3 PFC Converter Demonstration (DML\_PFC\_Demo)

The DML\_PFC\_Demo model (Figure 34) is a test system for PFC converter models, `pfc_avm` and `pfc_swm`. It can be used to compare the SWM and AVM or to evaluate different LVRT strategies for single-phase PFC converters. A timestep of 1  $\mu$ s should be used if the SWM is used. However, if only AVMs are used disabled, the model timestep can be increased to 50  $\mu$ s. The transmission system model is identical to that used in the DML\_Inverter\_Demo model.

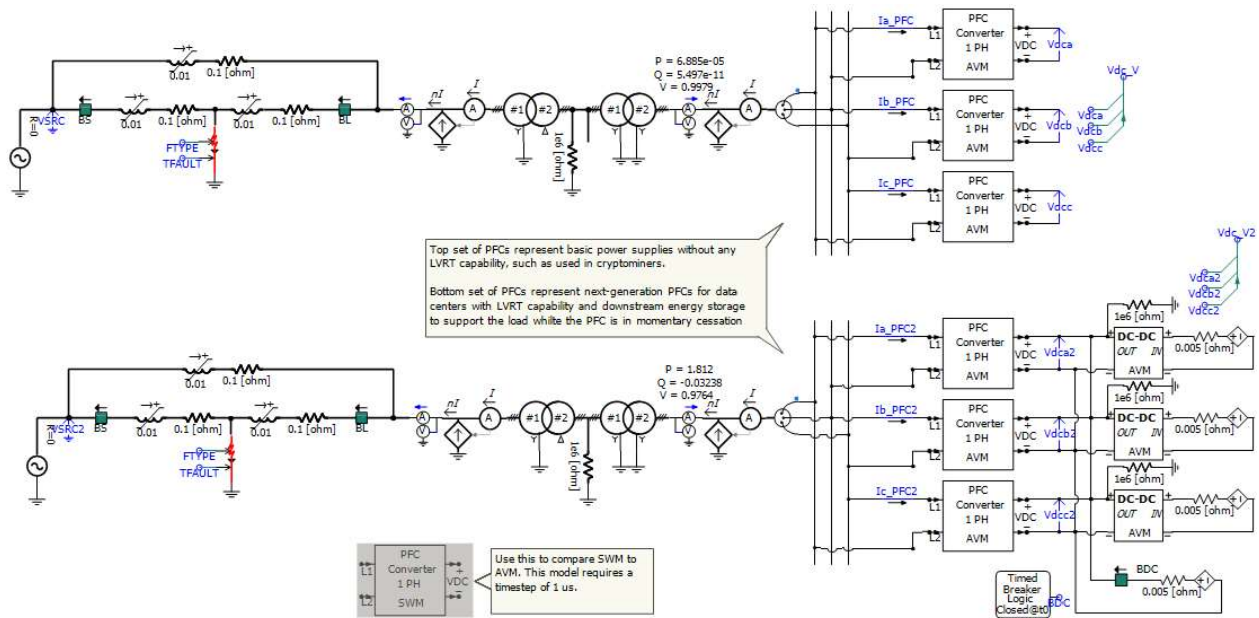

Figure 34: Overview of the DML\_PFC\_Demo Model.

Figure 35 compares the A PH current of the SWM to the AVM for a three phase fault at  $t = 3$  s. At roughly  $t = 3.11$  s, the PFC converter trips (due to a DC link overvoltage) and the current at the PCC drops to nearly zero. There is no visually apparent difference between the SWM and AVM, the two traces (red and blue) overlap closely.

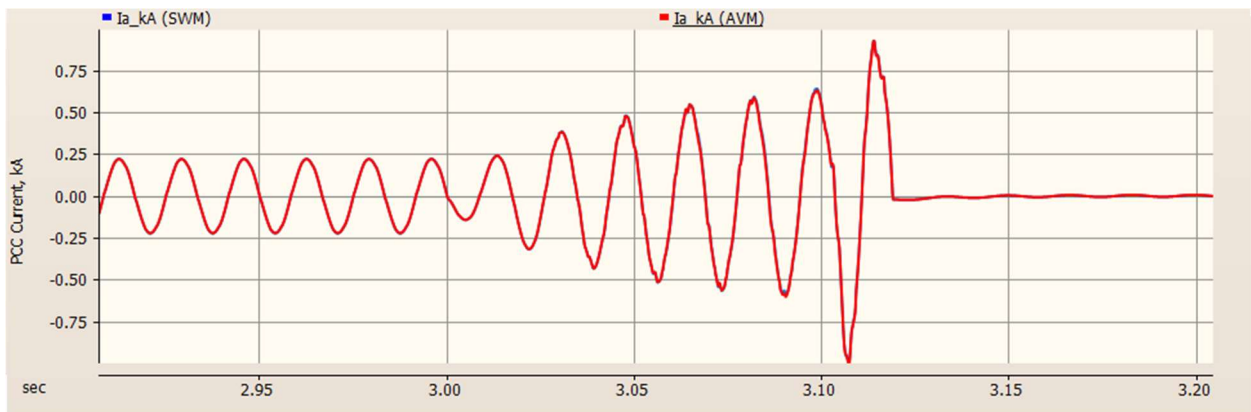

Figure 35: Comparison of Fault Response of pfc\_avm (Red) and pfc\_swm (Blue) Fault Response.

Figure 36 compares the fault response of a PFC without (red) and with (blue) ESS and LVRT ride-through capabilities. The ESS is integrated via a DC-DC converter (DC\_bi\_avm) as shown in the bottom right hand corner of Figure 34. For this converter, momentary cessation is enabled. Without ESS and momentary cessation, the PFC converter draws significant current during the fault, and trips when the fault is cleared due to a DC link overvoltage. With momentary cessation, the power supply regulates its input current to approximately zero during the fault—the brief spike observed at  $t = 3.10$  s is the result of the rapid voltage recovery following fault clearing. While not visible in Figure 36, the DC-DC converter supplies energy to the DC link while the PFC converter is in momentary cessation, allowing the load to continue functioning and providing a smooth transition back to grid power after the fault has cleared.

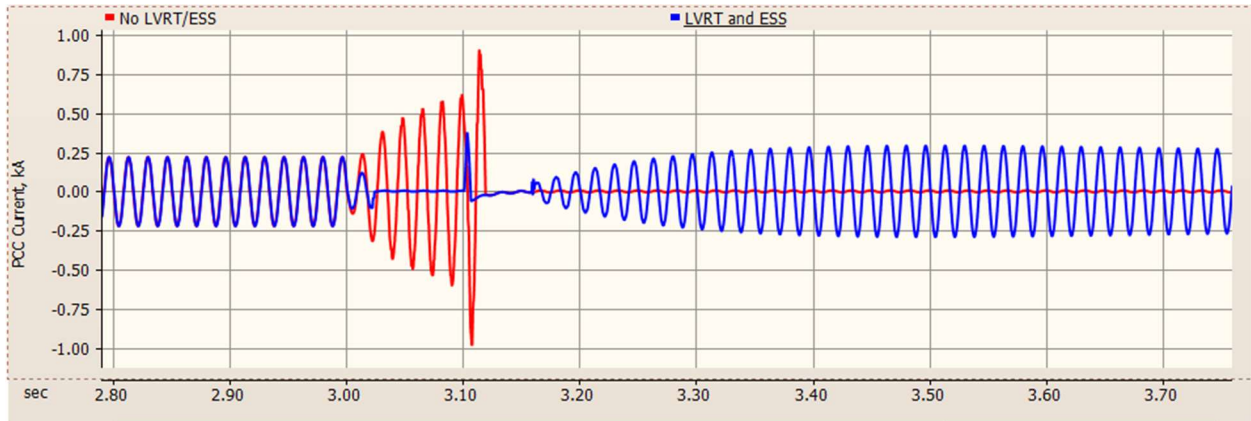

Figure 36: Comparison of Fault Response of PFC Without ESS to Provide LVRT (Red) and with (Blue).

### 5.4 Complete Data center Models

Before proceeding to describe the different data center models, we begin by discussing the transmission system model which is common to all the complete data center models included in the library (Figure 37). This model is meant to allow users to conveniently exercise different aspects of a data center’s dynamics, primarily by simulating transmission system faults. The model consists of an equivalent generator (a), transmission system (b), and controls for convenient setting of network parameters (c).

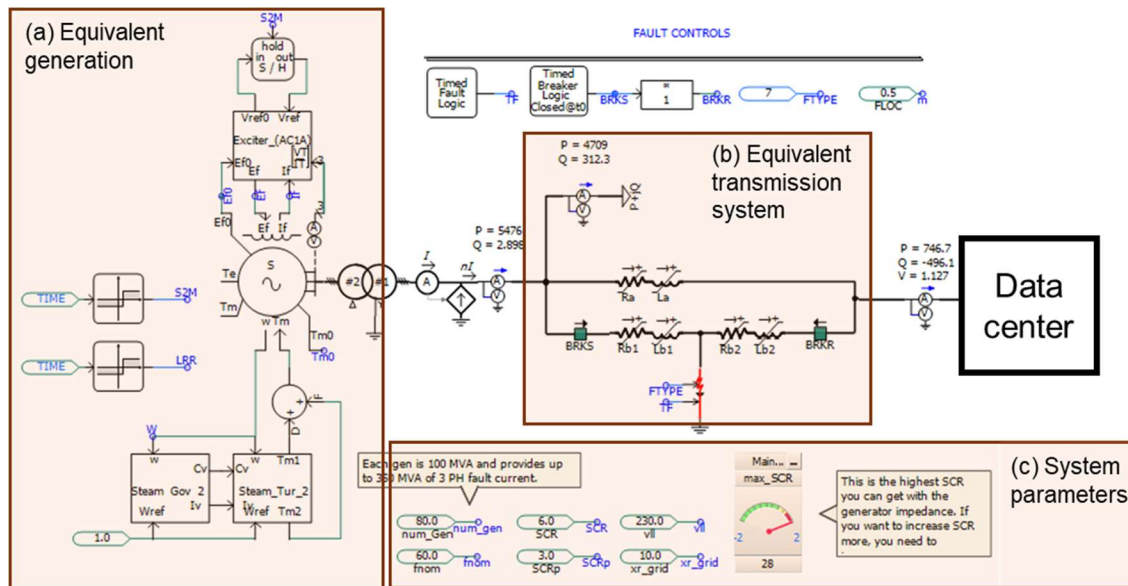

Figure 37: Transmission System Model Used for Complete Data Center Models.

The equivalent generator model uses a detailed synchronous machine model so that the effects of different data center ride-through and tripping behaviors on system frequency can be studied, as well as the ability of data center power electronics to maintain synchronism with the grid during weak grid conditions. Users should adjust the total generation by varying the value of “num\_gen.” A value of num\_gen = 1 results in a generator and generator step-up (GSU) transformer rated for 100 MVA that supplies 350 MVA of power to a bolted 3 PH fault on the high side of the GSU transformer.

The equivalent transmission system model allows for simulation of faults with varying electrical proximity to the data center while also capturing any potentially significant variation in short-circuit ratio (as defined based on the 3 PH fault current available at the data center PCC and rated capacity of the data center) that arises from fault clearing, which is implemented by opening the breakers labeled “BRKS” and “BRKR.”

Users define the data center short circuit ratio (SCR) when the breakers are closed using the constant labeled “SCR.” The SCR when the breakers are open is equal to “SCRp.” The value of SCRp must be lower than SCR—transmission system strength is always decreased by disconnecting lines, and violating this guidance will result in negative resistances and inductances that cause misleading simulation results. The “max\_SCR” meter indicates the highest possible SCR obtainable based on the current value of num\_gen and data center capacity. The values of SCR and SCRp must be lower than this value.

A fixed load component is connected at the high side of the GSU transformer (after the current scaling component) in order to simulate bulk system load on the equivalent generator. This is important as the loading of system generation will significantly alter the response of generator angle and frequency to faults and/or data center tripping. In the provided cases, the fixed load is configured to consist of 50% constant power load and 50% constant impedance load.

#### 5.4.1 Simple Data Center (DML\_DC1\_Simple)

The DML\_DC1\_Simple model implements the Simple data center design introduced in Section 2.1 (Figure 38). The proper usage for the facility parameters (a) is described in Table 10. There are many additional parameters that can be configured via the parameters dialog for the individual components in the model. Documentation for component level input parameters can be found in Section 6.0. ITE is represented using the pfc\_avm component (c).

**IMPORTANT:** PSCAD’s built-in current scaling component does not support variable input signals. Thus, it is necessary to manually change the value of No\_pump\_a, No\_PFC\_a, and No\_fan\_a (located in (b) Current scaling values section of Figure 38) to match the values shown in the adjacent control panel. This inconvenience may be resolved in future versions by either introduction of a current scaling component that supports variables or improvements made to the PSCAD compiler.

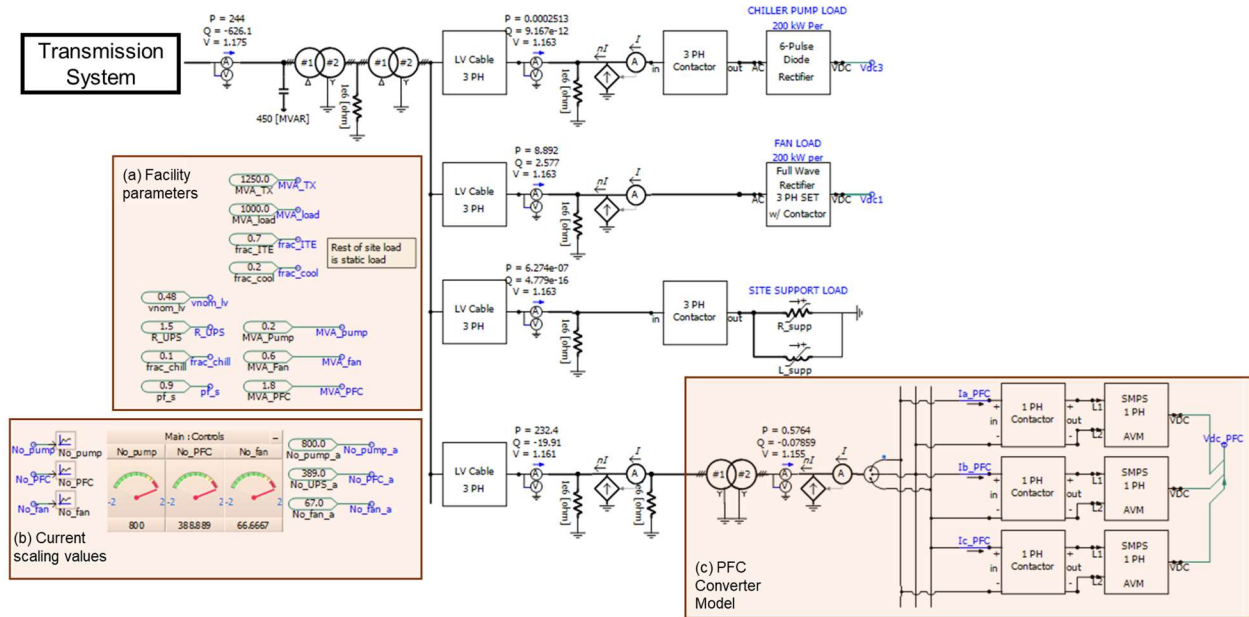

Figure 38: Overview of Simple Data Center Model.

Table 10: Facility Parameters for Simple Data Center.

Name	Units	Use
MVA_TX	MVA	In MVA solely because 3 PH transformer components don't support a variable rating, recommend setting to 1.2 to 1.5 times MVA_load.
MVA_load	MVA	Rated peak power consumption of the data center.
frac_ITE	N/A	Fraction (0 to 1) of peak power consumption allocated to ITE.
frac_cool	N/A	Fraction (0 to 1) of peak power consumption allocated to ITE. Whatever is not ITE or cooling load is assumed to be site support load and is modeled as a simple parallel RL circuit.
vnom_lv	kV	Nominal AC distribution voltage; recommended to leave at default value of 0.48 kV.
frac_chill	N/A	Fraction (0 to 1) of cooling load allocated to chillers (as opposed to fans).
pf_s	N/A	Power factor of site support load. Site support load is generally a small portion of total data center load and high precision for this value is unnecessary.
MVA_pump	MVA	MVA rating of individual pump model. Recommended to leave at default value of 0.2 MVA.
MVA_fan	MVA	MVA rating of individual fan model. Recommended to leave at default value of 0.6 MVA.
MVA_PFC	MVA	MVA rating of individual PFC converter model. Recommended to leave at default value of 1.8 MVA.

The kilowatt values for the fan and chiller pump loads are not tied to any specific hardware; these are simply the values for which the DC link capacitors have been sized. Current scaling components are used simply so that the user does not need to adjust passive components when adjusting the facility ratings.

### 5.4.2 Centralized UPS Data Center (DML\_DC2\_Central\_UPS)

The DML\_DC2\_Central model implements the Centralized UPS data center design introduced Section 2.1 (Figure 39). The proper usage for the facility parameters (a) is described in Table 11. There are many additional parameters that can be configured via the parameters dialog for the individual components in the model. Documentation for component level input parameters can be found in Section 6.0.

ITE is primarily represented using a double-conversion UPS constructed out of the `inv_gfl`, `inv_gfm_droop_avm`, `dc_bi_avm`, and `ups_ctrl` components as described in Section 4.1.1. The load connected to the UPS output is represented using `load_ai_train`, which can also be used to represent a constant demand by letting the compute and resting load be equal.

**IMPORTANT:** PSCAD’s built-in current scaling component does not support variable input signals. Thus, it is necessary to manually change the value of `No_pump_a`, `No_UPS_a`, and `No_fan_a` (located in (b) Current scaling values section of Figure 39) to match the values shown in the adjacent control panel. This inconvenience may be resolved in future versions by either introduction of a current scaling component that supports variables or improvements made to the PSCAD compiler.

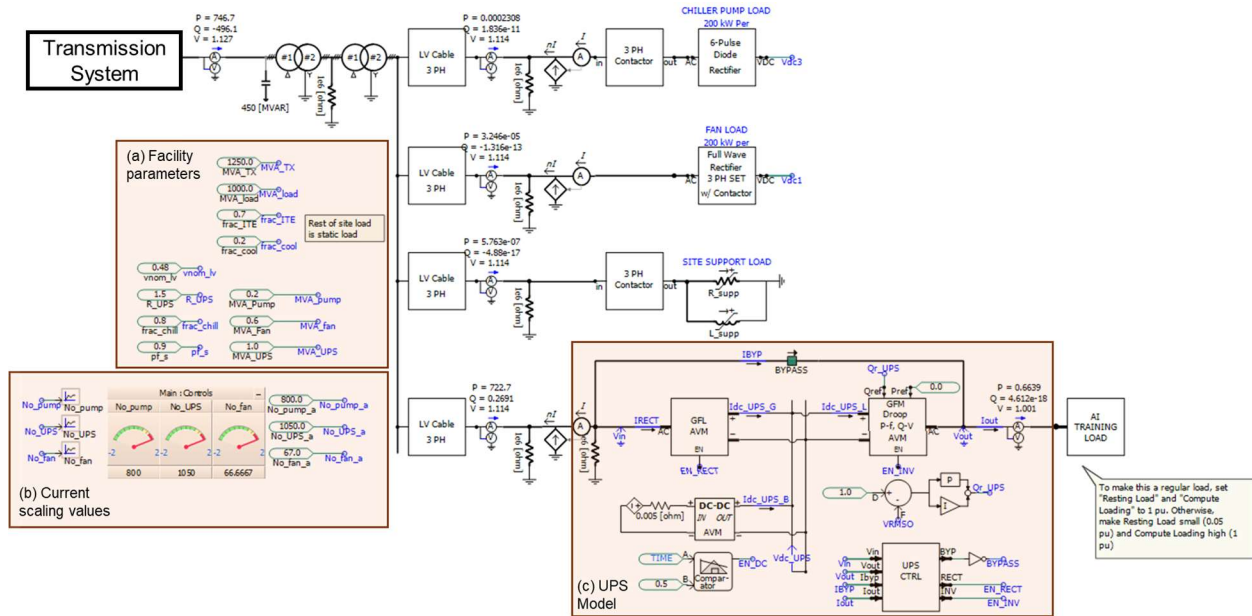

Figure 39: Overview of Data Center Model with Centralized UPS.

The proper usage for the facility parameters (a) is described in Table 11. There are many additional parameters that can be configured via the parameters dialog for the individual components in the model. Documentation for component level input parameters can be found in Section 6.0.

Table 11: Facility Parameters for Data Center with Centralized UPS.

Name	Units	Use
MVA_TX	MVA	In MVA solely because 3 PH transformer components don't support a variable rating, recommend setting to 1.2 to 1.5 times MVA_load.
MVA_load	MVA	Rated peak power consumption of the data center.
frac_ITE	N/A	Fraction (0 to 1) of peak power consumption allocated to ITE.
frac_cool	N/A	Fraction (0 to 1) of peak power consumption allocated to ITE. Whatever is not ITE or cooling load is assumed to be site support load and is modeled as a simple parallel RL circuit.
vnom_lv	kV	Nominal AC distribution voltage; recommended to leave at default value of 0.48 kV.
R_UPS	N/A	Sizing of UPS capacity relative to peak ITE demand. Usually varies from 1.2 to 2.0, depending on site reliability philosophy.
frac_chill	N/A	Fraction (0 to 1) of cooling load allocated to chillers (as opposed to fans).
pf_s	N/A	Power factor of site support load. Site support load is generally a small portion of total data center load and high precision for this value is unnecessary.
MVA_pump	MVA	MVA rating of individual pump model. Recommended to leave at default value of 0.2 MVA.
MVA_fan	MVA	MVA rating of individual fan model. Recommended to leave at default value of 0.6 MVA.
MVA_UPS	MVA	MVA rating of individual UPS model. Recommended to leave at default value of 1 MVA.

The kilowatt values for the fan and chiller pump loads are not tied to any specific hardware, these are simply the values for which the DC link capacitors have been sized. Current scaling components are used simply so that the user does not need to adjust passive components when adjusting the facility ratings.

### 5.4.3 Distributed UPS Data Center (DML\_DC3\_Dist\_UPS)

The DML\_DC3\_Dist\_UPS model implements the distributed UPS data center design introduced in Section 2.1 (Figure 3). The proper usage for the facility parameters (a) is described in Figure 40. There are many additional parameters that can be configured via the parameters dialog for the individual components in the model. Documentation for component level input parameters can be found in Section 6.0. ITE is represented using the `pfc_avm` component (c), which is configured to enter momentary cessation during voltage sags. Rack-level energy storage is represented using the `DC_bi_avm` component (d) and provides energy to the ITE DC link voltage when the PFC converter is in momentary cessation.

**IMPORTANT:** PSCAD's built-in current scaling component does not support variable input signals. Thus, it is necessary to manually change the value of `No_pump_a`, `No_PFC_a`, and `No_fan_a` (located in (b) Current scaling values section of Figure 40) to match the values shown in the adjacent control panel. This inconvenience may be resolved in future versions by either introduction of a current scaling component that supports variables or improvements made to the PSCAD compiler.

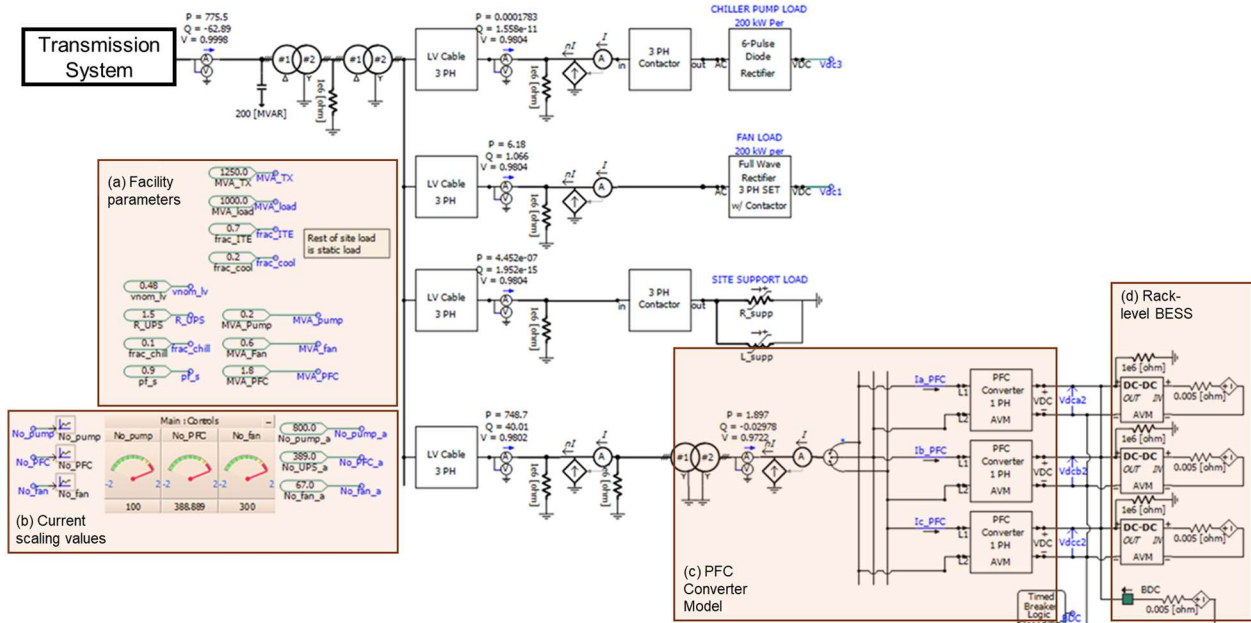

Figure 40: Overview of Data Center Model with Distributed UPS.

Table 12 lists the facility parameters for the distributed UPS data center.

Table 12: Facility Parameters for Distributed UPS Data Center.

Name	Units	Use
MVA_TX	MVA	In MVA solely because 3 PH transformer components don't support a variable rating, recommend setting to 1.2 to 1.5 times MVA_load.
MVA_load	MVA	Rated peak power consumption of the data center.
frac_ITE	N/A	Fraction (0 to 1) of peak power consumption allocated to ITE.
frac_cool	N/A	Fraction (0 to 1) of peak power consumption allocated to ITE. Whatever is not ITE or cooling load is assumed to be site support load and is modeled as a simple parallel RL circuit.
vnom_lv	kV	Nominal AC distribution voltage; recommended to leave at default value of 0.48 kV.
frac_chill	N/A	Fraction (0 to 1) of cooling load allocated to chillers (as opposed to fans).
pf_s	N/A	Power factor of site support load. Site support load is generally a small portion of total data center load and high precision for this value is unnecessary.
MVA_pump	MVA	MVA rating of individual pump model. Recommended to leave at default value of 0.2 MVA.
MVA_fan	MVA	MVA rating of individual fan model. Recommended to leave at default value of 0.6 MVA.
MVA_PFC	MVA	MVA rating of individual PFC converter model. Recommended to leave at default value of 1.8 MVA.

## 6.0 Component Models

DML contains PSCAD component definitions (in DML\_Components.pslx) which represent individual devices or functions. This section describes all the component definitions in the library. The component definitions in the PSCAD library file are all schematic based (instead of code based) and nothing is encrypted or black-boxed. It is intended that the schematics themselves serve as documentation of the exact implementation, and this section is intended more to describe the models at a high level and call out application notes which are not obvious from the schematics alone.

Throughout the user guide, the font `Courier New` denotes the usage of a component definition name.

### 6.1 DC-DC Buck-Boost Converter (AVM) – DC\_bi\_avm

The `DC_bi_avm` component implements a DC-to-DC buck-boost converter, which can produce an output DC voltage ranging from roughly 0 to 2 times the input DC voltage. An AVM is used, a timestep of 50  $\mu$ s or less is recommended. It is a bidirectional converter. Such converters are sometimes used to interface batteries with inverters, as they can be used to provide controlled charging and discharging of the battery. In the DML, it is used to represent the UPS battery charger and interface either batteries or supercapacitors with DC distribution buses.

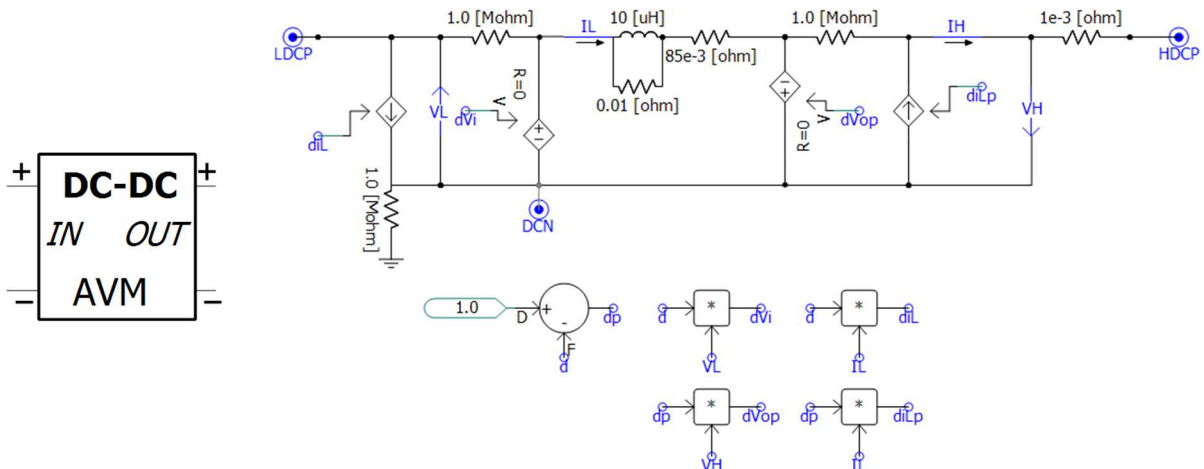

Figure 41: Icon (Left) and Main Electrical Schematic (Right) of `DC_bi_avm`.

The controller is built into the model and has two parallel control loops: there is a slow real power controller which tracks a power reference (e.g., to charge or discharge a battery). There is a fast DC voltage regulator which is designed to respond to transient undervoltages on the output DC bus.

Table 13 describes the input parameters. To avoid needing to resize passive components, it is recommended to implement alternate power and voltage ratings using PSCAD’s built in scaling components.

Table 13: Input Parameters for DC\_bi\_avm Component.

Name	Units	Use
Converter On/Off	Boolean	Enable or disable firing of the IGBTs
Rated Power	MW	Define active power base for controls. By default, passives are sized for 1 MW.
Power set-point	pu	Target for power regulator, e.g., to represent battery charger setpoint. Positive values cause power flow from input to output.
Nominal Output Voltage	kV	Define voltage base for controls. By default, passives are sized for 800 VDC input and 1200 VDC output.
Voltage setpoint	pu	Voltage regulator will only respond when voltage output drops below this magnitude. In a UPS application, set this lower than the setpoint in the UPS rectifier to avoid control instability.
Max. Mod. Index	pu	Maximum duty cycle; can leave as 1 in most cases.
Power Regulator, Prop. Gain	pu	PI control gains for regulation of active power, intended to be relatively slow.
Power Regulator, Time Const.	s	
Voltage Measurement Time Const.	s	First order low-pass filter for output voltage regulator.
Voltage Reg. Prop Gain	pu	PI control gains for regulation of output voltage, intended to be relatively fast.
Voltage Reg., Time Const.	s	

### 6.2 DC-DC Buck-Boost Converter (SWM) – DC\_bi\_swm

The DC\_bi\_swm component is a SWM alternative to DC\_bi\_avm. It has the same set of input parameters (see Table 13).

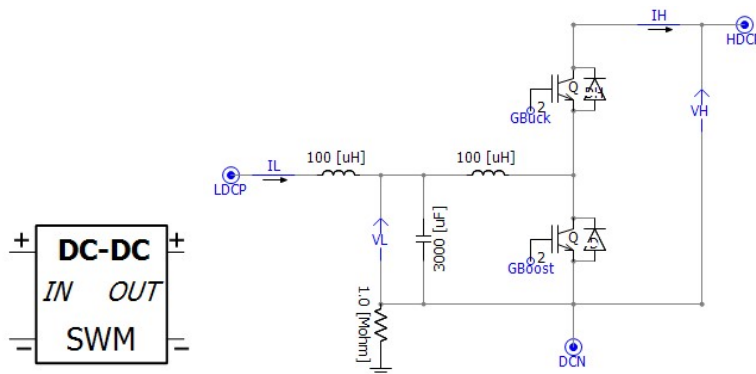

Figure 42: Icon (Left) and Main Hardware Schematic (Right) for DC\_bi\_swm Component.

### 6.3 GFM Droop Control – gfm\_droop

The `gfm_droop` component contains just the control loops necessary to implement GFM droop control in a three-phase inverter. It is used as a component in the GFM inverter models which use the droop-based approach for obtaining GFM operation. See `gfm_ibr_droop_avm` for a complete inverter model which uses this component. All input and output signals in per-unit.

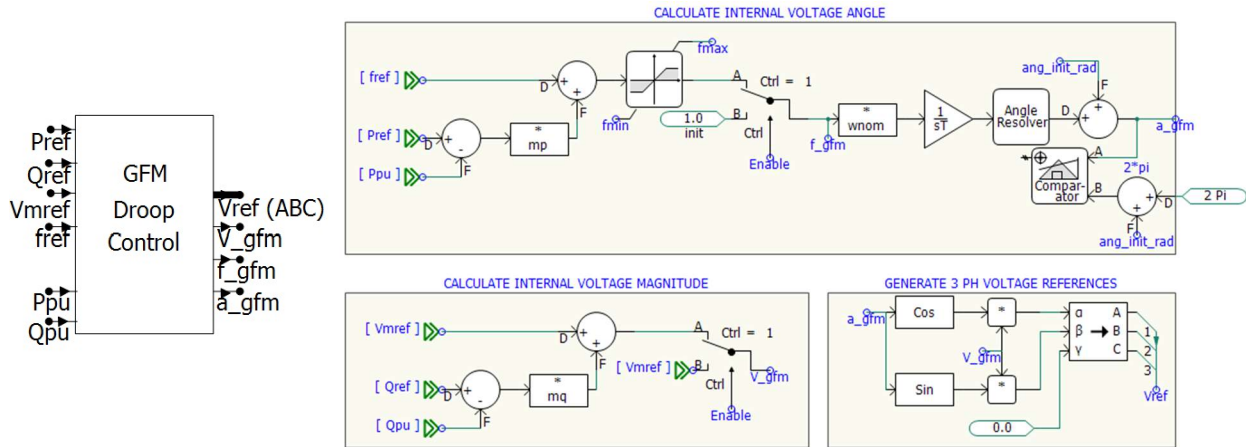

Figure 43: Icon (Left) and Main Control Elements (Right) for the `gfm_droop` Component.

Table 14: Input Parameters for `gfm_droop` Component.

Name	Units	Use
Nominal frequency	Hz	Defines AC frequency base
Droop Gain, Real Power	pu	N/A
Droop Gain, Reactive Power	pu	N/A
Maximum frequency	pu	N/A
Minimum frequency	pu	N/A
Initial voltage angle	degrees	Adjust this to obtain desired power flow at startup. If this angle differs too much from the bus voltage angle where the associated inverter is connected, the inverter may not successfully synchronize.
Startup time	s	Until simulation time exceeds this value, output voltage magnitude, frequency, and angle are forced to the voltage magnitude reference, nominal frequency, and initial voltage angle, respectively.

### 6.4 GFM Droop Control w/ Vdc Reg. – gfm\_droop\_vdc

For most cases where a GFM inverter is applied, it is assumed that DC link voltage is regulated to a constant value by some other component (e.g., the DC/DC converter for a battery). The `gfm_droop_vdc` component is a variant of `gfm_droop` that handles the less common (but

sometimes necessary) condition where the GFM inverter must contribute to DC link voltage regulation.

The `gfm_droop_vdc` component uses a DC voltage rather than AC active power to regulate its AC frequency. A proportional-derivative control (rather than a proportional control) is used to provide additional phase lead and improve the control's transient response [88].

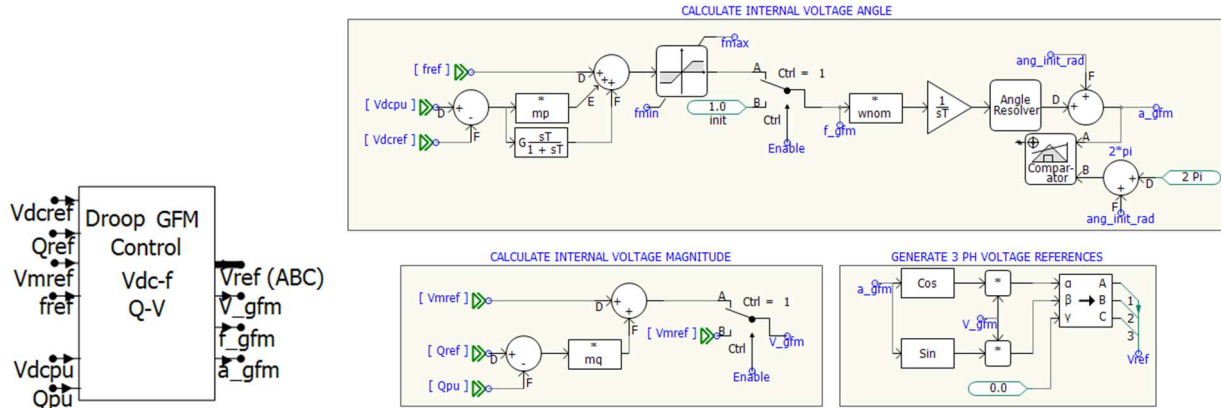

Figure 44: Icon (Left) and Main Control Diagram (Right) for `gfm_droop_vdc` Component.

Table 15: Input Parameters for `gfm_droop_vdc` Component.

Name	Units	Use
Nominal frequency	Hz	Defines AC frequency base
Droop Gain, DC Voltage	pu	N/A
Deriv. Gain, DC Voltage	pu	N/A
Deriv. Time Const.	s	N/A
Maximum frequency	pu	N/A
Minimum frequency	pu	N/A
Initial voltage angle	degrees	Adjust this to obtain desired power flow at startup. If this angle differs too much from the bus voltage angle where the associated inverter is connected, the inverter may not successfully synchronize.
Startup time	s	Until simulation time exceeds this value, output voltage magnitude, frequency, and angle are forced to the voltage magnitude reference, nominal frequency, and initial voltage angle, respectively.

### 6.5 dq-Domain current regulator – `ireg`

The `ireg` component implements a dq-domain current regulator, which varies a three-phase inverter's dq-domain modulation index to achieve a given current reference. This is a common control loop in IBR models as it allows for fast current limiting during grid faults. All input and output signals are in per unit. The `ireg` component will limit the modulation indices produced to within  $\pm 2$  pu but has no built-in current limiting.

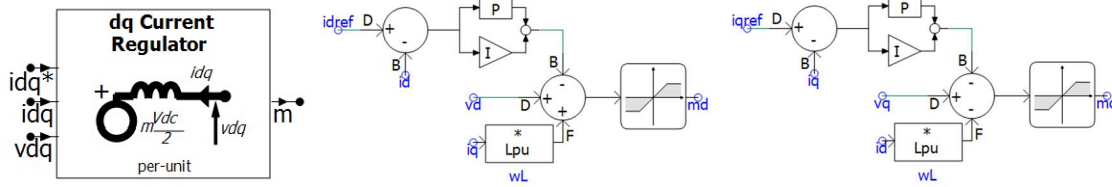

Figure 45: Icon (Left) and Main Controls (Center, Right) for the *ireg* Component.

Table 16: Input Parameters for *ireg* Component.

Name	Units	Use
Kp, Current Regulator	pu	Proportional gain for PI controllers
Ti, Current Regulator	s	Integral time constant for PI controls
AC Side Inductance	pu	Total series inductance between node where <i>vdq</i> is measured and the AC terminals of the inverter (which is producing an AC voltage as defined by <i>md</i> and <i>mq</i> ).

### 6.6 dq-Domain Current Limiter – *ilim\_dq*

The *ilim\_dq* component is used to limit a set of d- and q-axis current references such that the magnitude of the dq-domain current space vector is limited. This is done by choosing to either prioritize maximizing the d-axis current or the q-axis current. This component is used to limit the current references produced by an outer loop control prior to sending them to a current regulator (e.g., *ireg*).

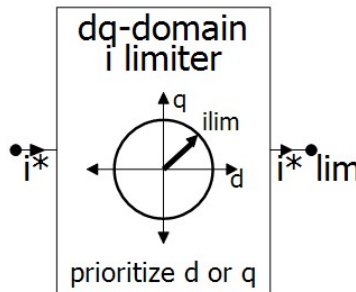

Figure 46: Icon for the *ilim\_dq* Component.

Table 13 describes the input parameters for the *ilim\_dq* component.

Table 17: Input Parameters for *ilim\_dq* Component.

Name	Units	Use
Current magnitude limit	pu	N/A
Prioritize d-axis current?	Boolean	A value of 1 results in d-axis prioritization. This field is a variable, so variable prioritization (e.g., q-axis priority only during voltage sags) is supported.

### 6.7 3 PH Inverter, AVM – `inv_avm`

The `inv_avm` component implements an AVM representation of a two-level voltage-source converter. This AVM is more sophisticated than many AVMs in that it includes built-in representation of PWM-level current clipping [89]. This is the purpose of the shunt current sources, which are active only when the current clipping is. If this feature is disabled, the model is equivalent to the commonly used AVM.

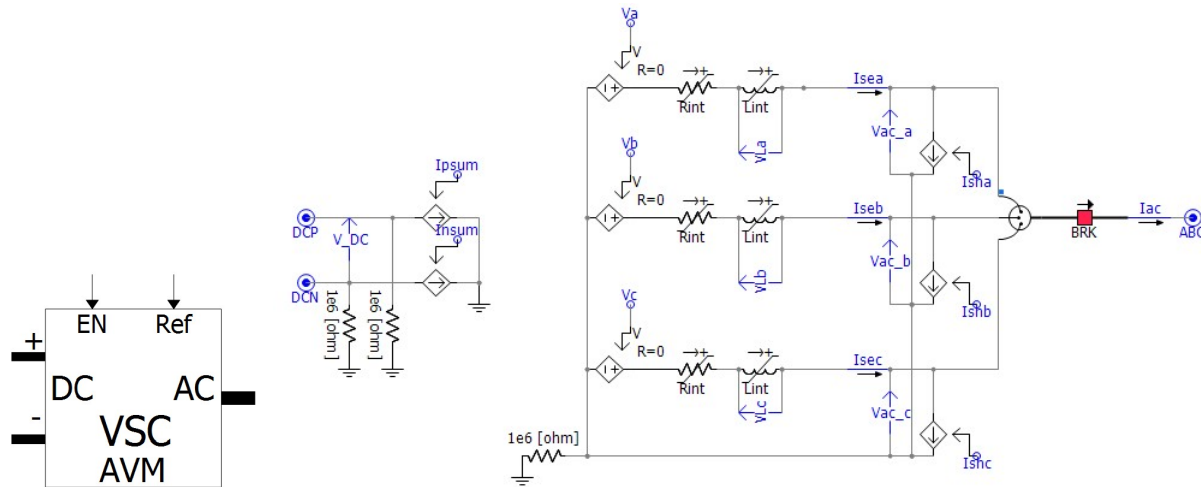

Figure 47: Icon (Left) and Main Hardware Schematic (Right) for `inv_avm` Component.

The inverter models that use the `inv_avm` component (e.g., `inv_gfl_avm` or `inv_gfm_droop_avm`) have built-in controls to derive input parameters for `inv_avm` without additional user input. These controls assume the inverter is operating at low-voltage (<1 kV). If using this model to represent high-voltage inverters (e.g., a 500 kV HVDC converter), the user will need to increase the internal resistance and inductance and tune them to match the appropriate SWM. However, this is unnecessary for the data center use cases that are the DML’s focus.

Table 18: Input Parameters for `inv_avm` Component.

Name	Units	Use
Internal Resistance	$\Omega$	Value of $R_{int}$ , a value equal to 10,000 times the simulation timestep in seconds works well for low-voltage inverters.
Internal Inductance	H	Value of $L_{int}$ , a value equal to the simulation timestep in seconds works well for low-voltage inverters.
Enable Inverter-Level Current Limit?	Boolean	Enables current clipping. If zero, the shunt current sources are forced equal to 0 amperes and the component is equivalent to the traditional AVM.
Current Limit	kA	Instantaneous current will be clipped to this value. It should be at least ~20% greater than any software-level current limiting.

### 6.8 3 PH Inverter, GFL – `inv_gfl`

The `gfl_inv` component represents a three-phase inverter with a grid following control. It is intended to represent small inverter-based generation or inverter-based loads, where more advanced grid support functions are seldom implemented. No plant-level controller is included.

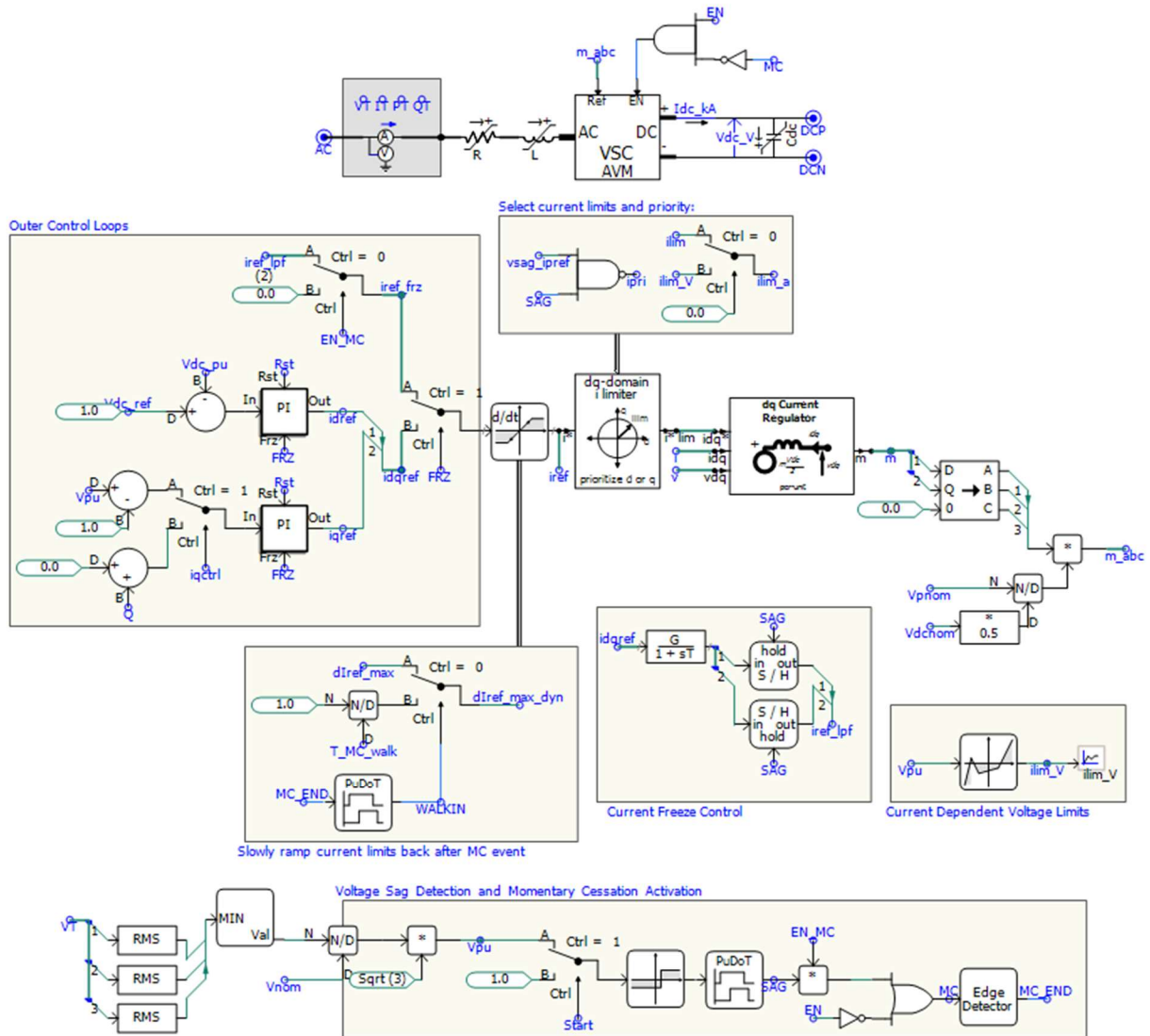

Figure 48: Main Hardware Schematic and Major Control Elements for `gfl_inv`.

An AVM is used and a timestep of 50  $\mu$ s or less is recommended. The component used for the AVM is `VSC_AVM` component.

A three-phase PLL is used to track the AC side voltage and control is performed in the  $dq$  domain. The d-axis current reference is determined by a DC voltage regulator. The q-axis current reference may be controlled using either a reactive power regulator or an AC voltage magnitude regulator. Based on these current references, the voltage references are determined using a  $dq$ -domain current regulator (the `ireg` component), which also provides current limiting.

Unless there is an AC side voltage sag, the d-axis current is prioritized (using the `ilim_dq` component).

The component supports several different AC-side low-voltage ride-through modes, based on a user-defined threshold for voltage sags. The component can be configured to prioritize  $q$ -axis current during voltage sags, providing reactive power support (if AC voltage regulation is also enabled). Momentary cessation with a controlled ramp-rate as well as constant current operation are also supported.

Table 19 and Table 20 describe the different input parameters for the `gfl_inv` component. To avoid needing to resize passive components, it is recommended to implement alternate power and voltage ratings using PSCAD's built in scaling components.

**Table 19: Ratings-Related Input Parameters for `gfl_inv` Component.**

<b>Name</b>	<b>Units</b>	<b>Use</b>
Nominal Apparent Power	MVA	Defines apparent power base for controls
Nominal L-L RMS Voltage	kV	Defines AC voltage magnitude base for controls
Nominal AC Frequency	Hz	Defines frequency base for controls
Nominal DC Link Voltage	kV	Defines DC voltage base for controls
AC Current Limit, pu	pu	Defines limit for current regulator limiter
DC Link Capacitance	$\mu$ F	Usually ranges from 1 to 10 mF per MVA
AC Side Inductance, pu	pu	Usually ranges from 0.05 to 0.2 pu.
Startup Time Delay, s	s	Until simulation time exceeds this value, controls are frozen and inverter AC voltage forced to magnitude of 1 pu and angle of 0 degrees.

Table 20: Controller-Related Input Parameters for `gfl_ibr` Component.

Name	Units	Use
Current Regulator, Proportional Gain	pu	PI control gains for inner control loop
Current Reg., Integral Time Constant	s	
Current Ref., Max Rate of Change, pu/s	pu/s	Limits the rate at which current reference can change, effects most prominent when IBR changes control mode when an AC voltage sag begins or ends.
DC Volt. Reg., Prop Gain, pu	pu	PI control gains for DC voltage outer control loop
DC Volt. Reg., Int Time Const., pu	s	
Reactive Power Control Method?	N/A	Drop-down menu—select control objective for q-axis current to be either reactive power or AC voltage magnitude regulation. Internally, $Q_{ref}$ is set to 0 and $V_{ac,ref}$ is set to 1 pu.
React. Pow. Prop Gain	pu	PI control gains for reactive power outer control loop
Reac. Pow. Int. Time Const	s	
Voltage Sag Threshold	pu	Magnitude threshold below which LVRT-related functions activate. Operates based on minimum of the three RMS line-to-ground voltages.
Enable Momentary Cessation?	Boolean	If nonzero, voltage sags will cause the VSC to be blocked for the duration of the sag (AC current will drop to zero) and the current commands will ramped back in at a set rate after the sag ends.
Freeze Current Ref. During Voltage Sags?	Boolean	If nonzero, voltage sags will cause the current reference commands to be frozen for the duration of the sag, resulting in constant current operation.
Momentary Cess. Pickup Time Delay	s	Time duration for which voltage sag must persist to trigger start momentary cessation
Momentary Cess. Dropout Time Delay	s	Time duration for which voltage sag must be absent to trigger end of momentary cessation.
Momentary Cess., Walk-In Time	s	Time duration over which the AC current is ramped back in after the end of momentary cessation.

### 6.9 3 PH Inverter, GFM, Droop Control, AVM – `inv_gfm_droop_avm`

The `gfm_ibr_droop_avm` component represents a three-phase inverter that uses a droop-based GFM control (`gfm_droop`). The inverter is represented with an AVM (`inv_avm`). A timestep of 50  $\mu$ s or less is recommended.

A single-layer control is used, meaning that there is no voltage or current regulator used. Fast current limiting is done at the PWM-level using hysteresis control. An optional, slower current limiter (`stage2_ilim`) may be used as well. This second stage can improve the inverter's ability to remain synchronized during close-in, long-lasting faults.

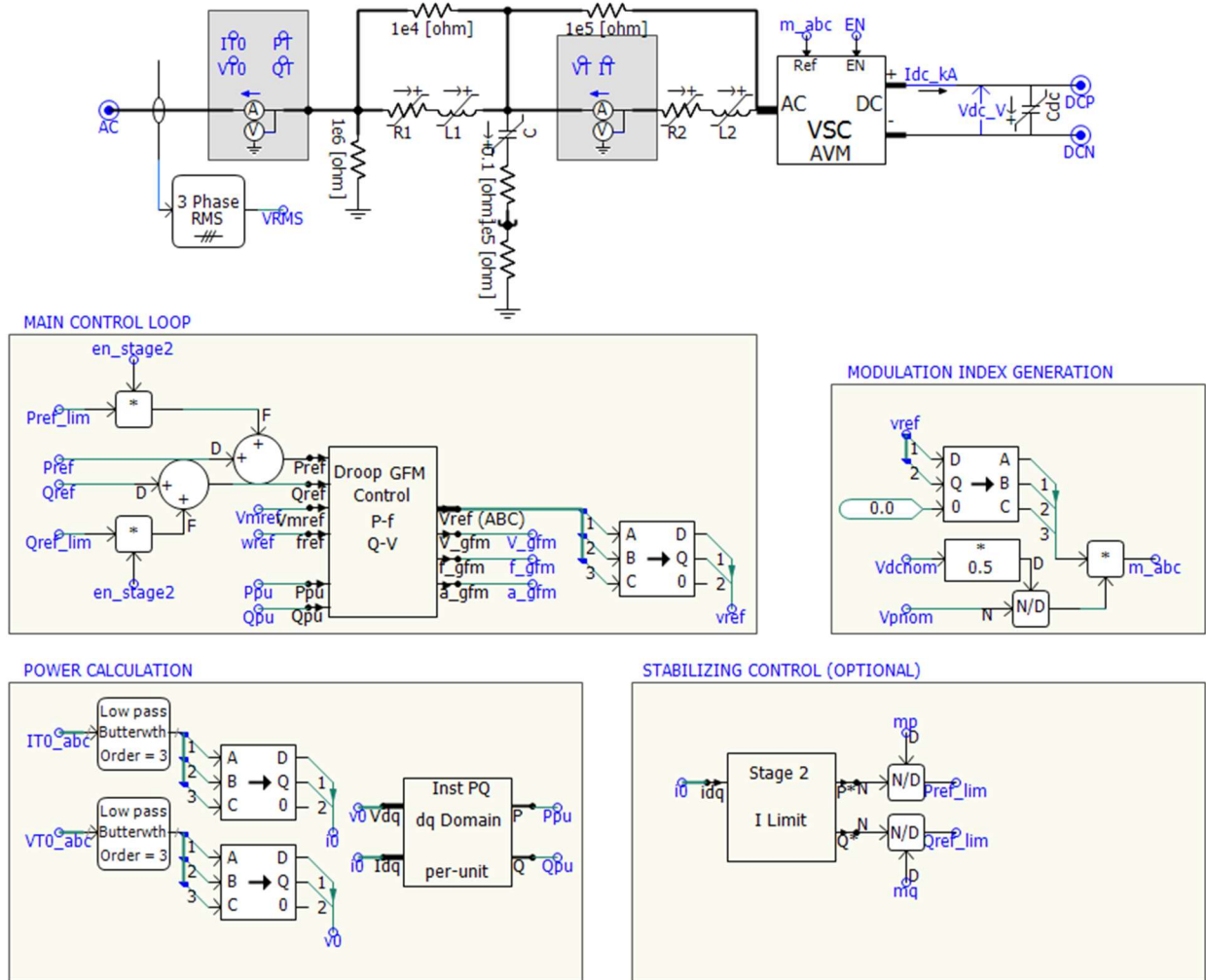

Figure 49: Hardware Schematic (Top) and Major Control Features (Bottom Four Rectangles) for `inv_gfm_droop_avm` Component.

**NOTE:** The AVM present in `inv_avm` differs from the traditional AVM in that it supports an AVM representation of hysteresis current limiting, such as that used in `gfm_ibr_droop_swm`.

Table 21: Ratings-Related Input Parameters for `inv_gfm_droop_avm` Component.

Name	Units	Use
Nominal Apparent Power	MVA	Defines apparent power base for controls
Nominal Voltage	L-L RMS kV	Defines AC voltage magnitude base for controls
Nominal AC Frequency	Hz	Defines frequency base for controls
Nominal DC Link Voltage	kV	Defines DC voltage base for controls
DC Link Capacitance	$\mu$ F	Usually ranges from 1 to 10 mF per MVA
LCL Filter Total Inductance	pu	Usually ranges from 0.05 to 0.2 pu.
LCL Filter Capacitance	$\mu$ F	N/A
Startup Time Delay, s	s	Until simulation time exceeds this value, controls are frozen and inverter AC voltage forced to magnitude of 1 pu and angle of 0 degrees.

Table 22: Control-Related Input Parameters for `inv_gfm_droop_avm` Component.

Name	Units	Use
Enable Current Clipping?	Boolean	Make nonzero to enable “clipping” of instantaneous currents above user-set limit.
AC Current Limit, pu	pu	Defines current limit for current clipping. A value of at least 1.2 pu is recommended to avoid stability issues.
Enable Stage 2 I Limit?	Boolean	Make nonzero to enable stabilizing control ( <code>stage2_ilim</code> ), which has built-in current limit of 1 pu.
Frequency droop	pu	Proportional gain for $P - f$ droop control
Voltage droop	pu	Proportional gain for $Q -  V $ control
Power calculation, Time Const.	s	First-order low-pass filter for active and reactive power calculations. Strongly affects the bandwidth of droop control.

### 6.10 3 PH Inverter, GFM, Droop Control, SWM – `inv_gfm_droop_swm`

The `gfm_ibr_droop_swm` component represents a three-phase inverter that uses a droop-based GFM control (`gfm_droop`). The inverter is represented with a switching model (`inv_swm`). A timestep of 5  $\mu$ s or less is recommended. For grid level studies, the AVM version (`gfm_ibr_droop_avm`) is recommended instead of this component, as it permits a much larger simulation timestep to be used (50  $\mu$ s instead of 5  $\mu$ s). The two models provide very similar responses for grid disturbances such as faults [89]. The main purpose for including this model is to allow users to validate the AVM’s response against a SWM.

The `gfm_ibr_droop_swm` component has the same input parameters as `gfm_ibr_droop_avm` (see Table 21 and Table 22).

### 6.11 3 PH Inverter, SWM – `inv_swm`

The `inv_swm` component implements a two-level IGBT-based voltage-source converter. The IGBTs themselves are approximately ideal and basic triangular PWM control is included.

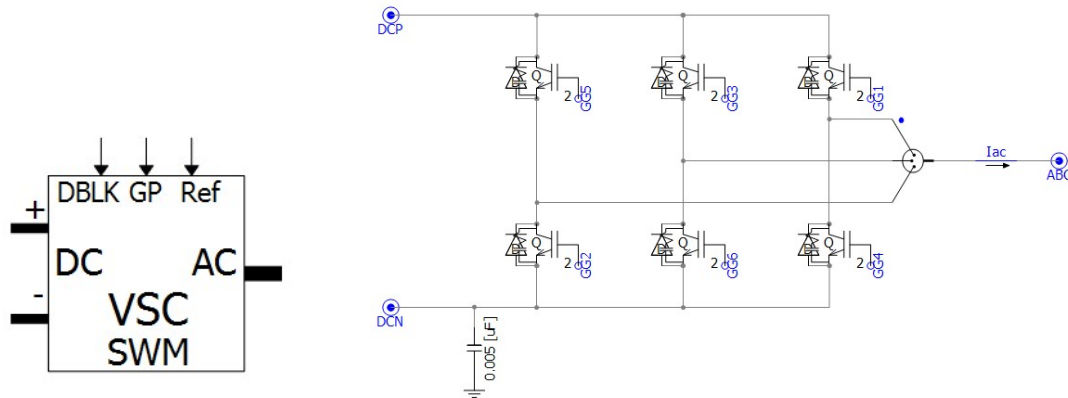

Figure 50: Icon (Left) and Main Hardware Schematic (Right) for `inv_swm`.

Both the DBLK and GP inputs permit blocking of the IGBT firing. DBLK is a 1-dimensional signal and is used to enable or disable all six switches. GP is a 6-dimensional signal used to block individual switches, which permits convenient representation of device-level current limiting such as the current clipping used in the `inv_gfm_droop_swm` component.

The only input parameter for `inv_swm` is the carrier frequency for the PWM, given in Hz.

### 6.12 Variable AI Training Load – `load_ai_train`

Training and inference for large AI models is most quickly done by operating large quantities (e.g., 200,000+) computing devices in parallel. The actual compute burden varies rapidly as individual computing tasks are completed and new tasks are initiated. Aggregated at a facility level, this corresponds to very large and rapid oscillations in power demand. The `load_ai_train` component is a convenient tool for producing very simplified versions of oscillating waveforms. Its simplicity makes it convenient for producing conservative waveforms targeting specific frequencies. If actual load profile data is available, use the `load_playback` component instead.

The `load_ai_train` component does not explicitly represent AI training processes. It is a time varying resistor, which cycles between large and small values based on the frequencies set by the user. If the component is connected to a bus with a relatively constant voltage magnitude (e.g., the output of a double-conversion UPS or a tightly regulated DC bus voltage), this simplified approach is appropriate. However, it is likely a poor representation of the training processes' response to large voltage deviations.

Table 23: Input Parameters for `load_ai_train` Component.

Name	Units	Use
Nominal AC Voltage, kV RMS L-L	kV	Defines voltage base
Nominal Power	MW	Defines active power base
Compute/Rest Frequency (Slow)	Hz	Frequency of slow variations in demand
Compute Block Frequency (Fast)	Hz	Frequency of fast variations in demand. Should be an integer multiple of the Compute/Rest Frequency (e.g., 10, 16, or 20).
Compute Loading	pu	Active power consumed at high loading level.
Resting Load	pu	Active power consumed at low loading level.
Load Step Time Constant	s	Time constant of first-order low-pass filter applied to time-varying resistance. A value of several milliseconds approximates the filtering effect of the low voltage power supplies.
Start Time	s	Load is fixed to compute loading level until simulation time exceeds this value.

Figure 51 illustrates the active power waveform the `load_ai_train` component is intended to implement, with annotations indicating how the input parameters relate to the waveform.

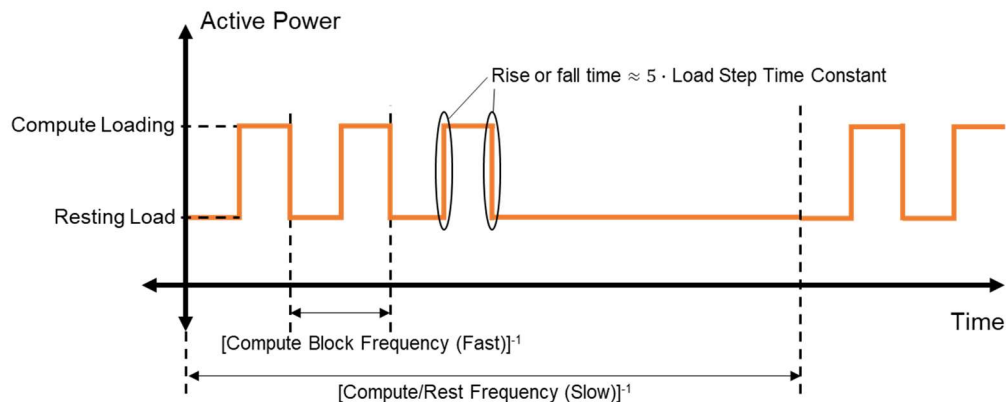

Figure 51: Simplified AI Training Waveform and Relationship with `load_ai_train` Component Parameters.

### 6.13 Playback-Based Electronic Load – `load_playback`

The `load_playback` component is intended to be used in conjunction with PSCAD’s built in “File Read” component to play user-specified active power waveforms into a system model. This can be used to evaluate how rapidly-varying data center demand variations affect nearby devices such as generators and other power electronics.

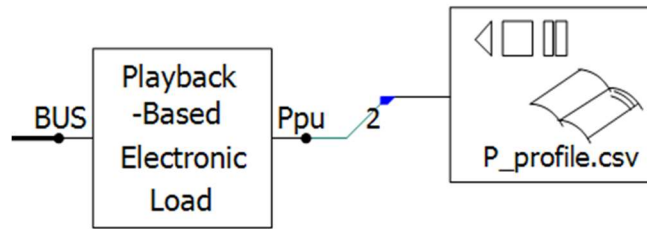

Figure 52: Icon for `load_playback` Component and Intended Connectivity with PSCAD’s File Read Component.

The File Read component is not implemented within the `load_playback` component due to compile-time issues related to generation of links to external files within a submodule. It is recommended to format the desired load profile data into a two-column .csv file, with the first column containing sample times and the second column containing per-unit active power demand. It should then be placed in the same file folder as the PSCAD project in use. Figure 53 illustrates the recommended settings for the File Read component. The delay value (in seconds) should be set large enough to allow the model to initialize before beginning playback.

Name for Identification	
File Name	P_profile.csv
Path to the File Given as	relative path
Number of Columns in the Output File	2
Sampling Time Information	first columns contains sampling time
At the End of Datafile	rewind and replay again
sampling Frequency	6400.0 [Hz]
Delay	1
Before the Delay	zero

Figure 53: Recommended Parameters for File Read Component for Use with `load_playback`.

The `load_playback` component includes current limiting and momentary cessation functions, which allow for a basic representation of an electronic load’s response to large changes in terminal voltage magnitude. These are simplified implementations of the more detailed fault responses present in the `gfl_ibr` component and allow the user to include external load profiles in scenarios including faults while avoiding the wildly unrealistic current waveforms or numerical stability issues that simple constant power loads can exhibit during such conditions. Figure 54 illustrates an example response for the `load_playback` component to a close-in three-phase fault.

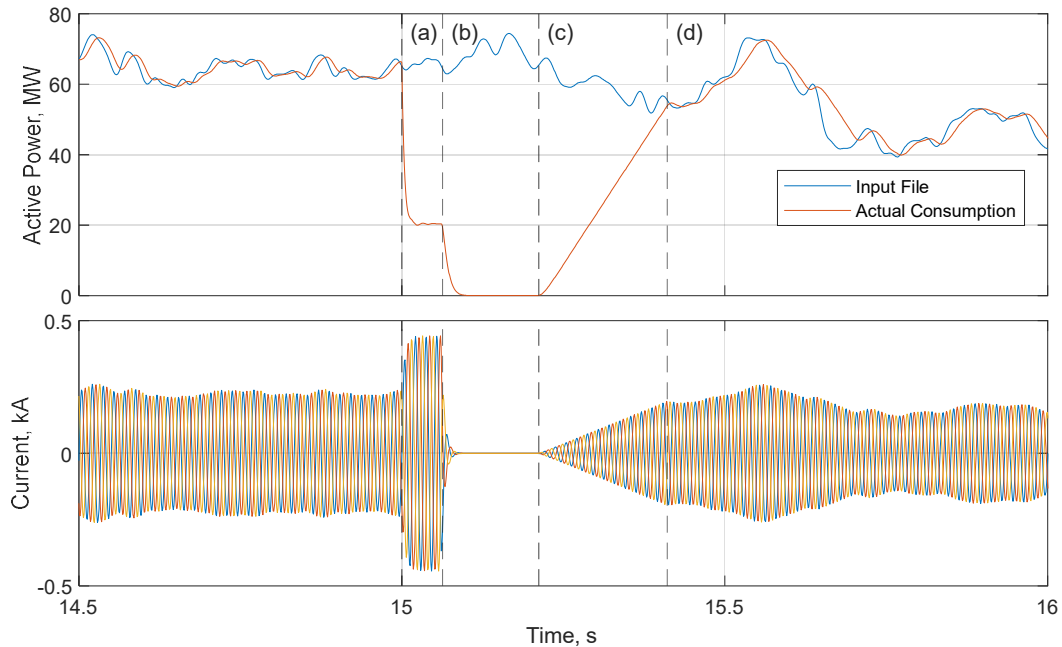

Figure 54: Exemplar Response of `load_playback` Component to Close-In 3 PH Fault Initiated at  $t = 15$  s and Cleared at  $t = 15.1$  s. Active Power Consumption Dips at Time (a) as the Load Current is Maintained within the Specified Limit of Roughly 400 A. At Time (b), the `load_playback` Component Enters Momentary Cessation and at Time (c), which is Shortly After the Fault is Cleared, Exits Momentary Cessation. The Ramp Rate of the Returning Load Current is Also Limited and Ramping Terminates at Time (d).

Observe that the fault does not halt or pause playback of the input file (i.e., it is assumed that the site-level process is continuing and supported by some on-site energy storage). Additionally, the post-undervoltage ramp-rate limiting affects the current limits rather than the current itself, meaning that the load will return to normal operation more quickly if it is operating at less than rated load.

Table 24: Input Parameters for `load_playback` Component.

Name	Units	Use
Nominal Active Power	MW	Defines nominal active power base.
Nominal Voltage	kV L-L RMS	Defines nominal voltage base.
Nominal Frequency	Hz	Defines nominal frequency base.
Current Limit	pu	Define current limit during voltage sags. A value of 1.25 is reasonable for most electronics with ride-through capability.
Current Source Time Constant	s	First-order low-pass filter to approximate response of electronic controls. A value of 2 to 10 ms is reasonable.
Enable UV Cessation?	Boolean	If nonzero, the load current will be regulated to zero in response to undervoltages below a set threshold for a set time delay.
UV Cessation Pickup	pu	Voltage magnitude threshold for entering UV cessation Operates based on the lowest RMS L-G voltage magnitude.
UV Cessation Pickup Time Delay	s	Voltage magnitude must be below UV Cessation Pickup for this time duration for the load to enter UV Cessation.
UV Cessation Dropout Time Delay	s	For UV cessation to end, the voltage magnitude must exceed the UV Cessation Pickup for this time duration.
Post-UV Reconnection Ramp Time	s	Time over which current limits are ramped from 0 to rated limits after UV cessation has ended. If load current is less than the current limit, the time to return to normal operation will be reduced proportionally. For example, assume the current limit is 1.2 pu and the Post-UV Reconnection Ramp Time is 2 seconds. If the normal load current at this time is 0.4 pu, it will take the load $(0.4 / 1.2) \times 2 = 0.667$ s to return to normal operation.

### 6.14 Lumped LV Cable, 1 PH – `LV_cable_1PH`

See `LV_cable_3PH`. This component exists because PSCAD does not allow the dimensions of nodes on modules to vary dynamically. This model differs from `LV_cable_3PH` only in that the electrical nodes on this component have a dimension 1, instead of 3.

### 6.15 Lumped LV Cable, 3 PH – `LV_cable_3PH`

A lumped-parameter model for low-voltage cables, specifically meant for convenient (but relatively low-fidelity) representation of the low- and medium-voltage cables used in collection/distribution circuits in large industrial facilities or inverter-based generation plants. When performing EMT studies of such applications, it is often necessary to have some thoughtfully-placed resistances to damp unrealistic and spurious transients, but it can be time consuming to place these. This model allows for some credible damping to be added without the large input data burden associated with a more formal cable constants routine.

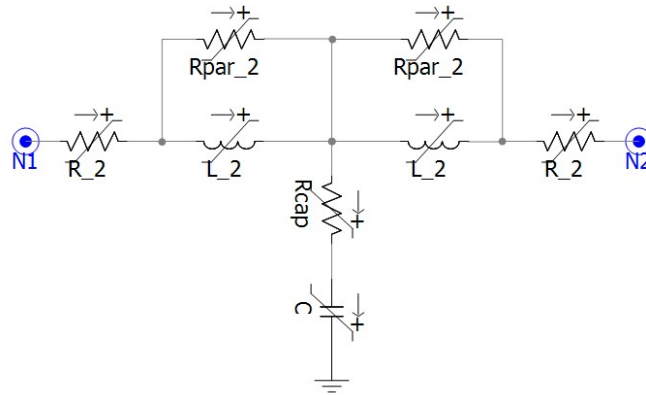

Figure 55: Topology of LV\_cable\_3PH.

A T-circuit is used instead of a  $\pi$ -circuit to ensure there is at least some inductance present in the same mesh as the capacitive current whenever the capacitor is suddenly discharged (e.g., due to a fault). A parallel damping resistance (Rpar) and series shunt resistance (Rcap) are used to approximate the frequency dependent losses of the cable, providing some attenuation of high-frequency switching noise and/or numerical oscillations.

The LV\_cable\_3PH component provides no representation of zero-sequence coupling—the underlying assumption is that this cable model is being used for grid-level studies wherein the zero-sequence networks of the data center and the grid are isolated from one another via delta-wye transformers.

Table 25: Input Parameters for LV\_cable\_3PH Component.

Name	Units	Use
Resistance	$\Omega/1000$ ft	N/A
Inductance	H/1000 ft	N/A
Avg. Length	ft	Assumed length of a single circuit
No. of Parallel Circuits	N/A	Series inductance, resistance is decreased proportionally to this value while shunt capacitance is increased proportionally.
Propagation Speed	Fraction of speed of light	Capacitance is estimated based on inductance and lossless transmission line equation. Usually in the range of 0.8 to 0.9 for low-voltage cables—this value does not include reduction in propagation speed from series resistance.
Cutoff Frequency, Hz	Hz	Frequency at which parallel damping resistance is equal to magnitude of impedance from series inductance.

### 6.16 1 PH Rectifier with PFC, AVM – pfc\_avm

The pfc\_avm component is a variation of the pfc\_swm component that uses an AVM. The IGBT of the boost converter is replaced with controlled current and voltage sources. A timestep of 50  $\mu$ s or less is recommended. For grid-level studies, users are encouraged to use this AVM variant instead of the SWM.

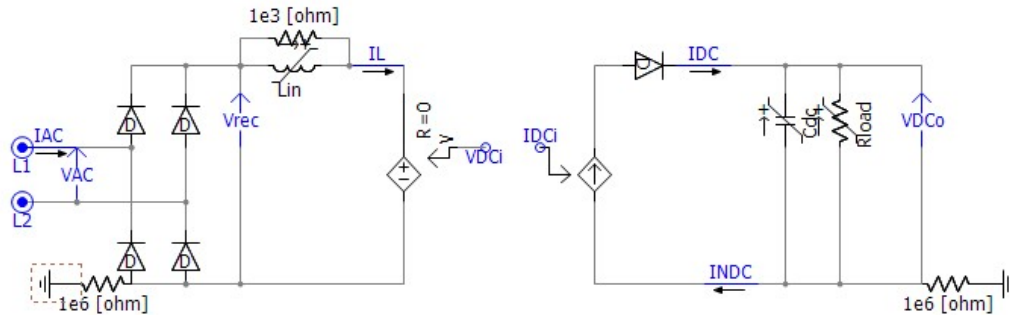

Figure 56: Main Hardware Schematic for `pfc_avm`.

The input parameters for `pfc_avm` are the same as those for `pfc_swm` (see Table 29), with the exception that the carrier frequency is absent as there is no PWM represented in `pfc_avm`.

Note that, as the `pfc_avm` component contains a built-in load but no built-in energy storage, activation of the momentary cessation function will usually cause rapid DC link voltage collapse unless a DC-DC converter with energy storage is connected to the DC link. See the system models `DML_DC_Dist_UPS` or `DML_PFC_Demo` or examples of how to do this.

Table 26: Device Rating Parameters for `pfc_avm` Component.

Name	Units	Use
Nominal Power Consumption	MW	Defines power consumption of Rload at nominal voltage
Nominal AC Voltage	kV RMS	DC link voltage is assumed to be 1.6 times this value
DC Link Capacitance, uF	$\mu\text{F}$	N/A
Boost Converter Inductance	H	N/A
Model Startup Time	s	Protection functions are disabled until simulation time exceeds this value.

Table 27: Controller Setting Parameters for `pfc_avm` Component.

Name	Units	Use
Measurement Time Constant	s	First-order low pass filter applied to voltage, current measurements used in control loops.
Volt. Reg., Prop Gain	$A/V^2$	DC voltage regulator (outer) control loop, determines amplitude of current reference
Volt. Reg., Int. Time Constant	$A/V^2\text{-s}$	
Curr. Reg., Prop Gain	$1/A$	Inductor current regulator (inner) control loop, determines modulation index.
Enable Momentary Cessation?	Boolean	If nonzero, voltage sags will cause the current to be regulated to zero for the duration of the sag.
Voltage Sag Threshold	pu	Magnitude threshold below which a voltage sag is declared. Operates based on RMS input voltage.
Momentary Cess. Pickup Time Delay	s	Time duration for which voltage sag must persist to trigger start momentary cessation
Momentary Cess. Dropout Time Delay	s	Time duration for which voltage sag must be absent to trigger end of momentary cessation.

Table 28: Protection Setting Parameters for `pfc_avm` Component.

Name	Units	Use
Enable DC Undervoltage trip?	Boolean	N/A
DC Undervolt., Voltage Thresh.	pu	DC link undervoltage element, trips PFC front-end if measured voltage drops below set threshold for set time period.
DC Undervolt., Pickup Time Delay	s	
Enable DC Overvoltage trip?	Boolean	N/A
DC Overvolt., Voltage Thresh.	pu	DC link overvoltage element, trips PFC front-end if measured voltage drops below set threshold for set time period.
DC Overvolt., Pickup Time Delay	s	
Enable Overcurrent trip?	Boolean	N/A
Overcurrent, Current Thresh.	pu	AC overcurrent element, trips PFC front-end if measured voltage drops below set threshold for set time period.
Overcurrent, Pickup Time Delay	s	

### 6.17 1 PH Rectifier with PFC, SWM – `pfc_swm`

The `pfc_swm` component is a single-phase switched mode power supply with a full bridge diode front-end and DC/DC boost converter which provides (distortion) power factor correction. While previously used specifically to replicate the grid dynamics of cryptocurrency mining hardware [64], the design’s major elements are commonly used in single phase power supplies for electronics. In the PMEL examples, it is used to represent small electronic loads.

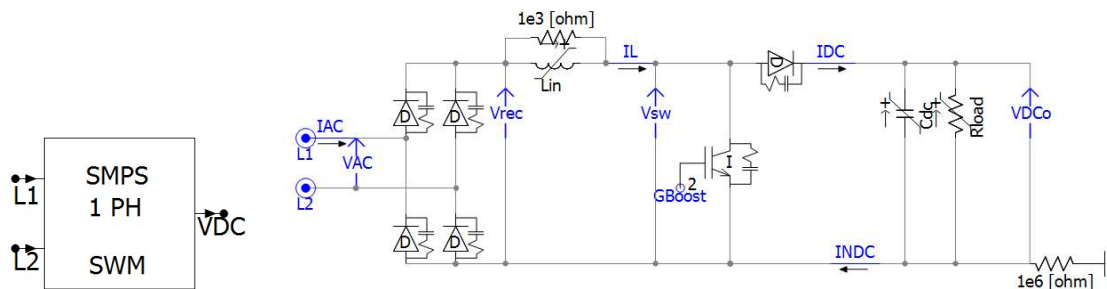

Figure 57: Icon (Left) and Main Hardware Schematic (Right) for `pfc_swm`.

The `pfc_swm` requires a high switching frequency (e.g., many tens of kilohertz) to function properly. A timestep of 1  $\mu$ s or less should be used—users are encouraged to use the AVM variant (`pfc_avm`) for grid-level studies. The purpose of developing this SWM was to verify the sufficiency of the AVM.

The SMPS control varies the duty cycle of GBoost to maintain  $V_{DCo}$  at a constant reference. An intermediate current regulator is also used to regulate  $I_L$  to be a rectified sine wave. This is the power factor correction stage—its effect is to make  $I_{AC}$  roughly sinusoidal, instead of the distorted waveform associated with a simple diode rectifier. This is the primary feature that causes the grid-level behavior of the PFC converter to differ so significantly from that of a basic diode rectifier (e.g., of the type used in `rect_3x_full_wave`).

In a real power supply, there are additional converters and electronics downstream to further condition the voltage for the electronics. For grid-level studies, these are reduced simply to  $R_{load}$ , which can be varied to simulate varying compute workloads.

**Table 29: Input Parameters for `pfc_swm` Component.**

Name	Units	Use
Nominal Power Consumption	MW	Defines power consumption of Rload at nominal voltage
Nominal AC Voltage	kV RMS	DC link voltage is assumed to be 1.6 times this value
Switching Frequency, Hz	Hz	Carrier frequency for triangular PWM
DC Link Capacitance, $\mu$ F	$\mu$ F	N/A
Boost Converter Inductance	H	N/A
Measurement Time Constant	s	First-order low pass filter applied to voltage, current measurements used in control loops.
Volt. Reg., Prop Gain	$A/V^2$	DC voltage regulator (outer) control loop, determines amplitude of current reference
Volt. Reg., Int. Time Constant	$A/V^2$ -s	
Curr. Reg., Prop Gain	$1/A$	Inductor current regulator (inner) control loop, determines modulation index.
Curr. Reg., Int. Time Constant	$1/A$ -s	

## 6.18 PI Controller with Anti-Windup Logic – `PI_AntiWindUp`

The `PI_AntiWindUp` component is a simple modification of the basic PI controller to include two additional functions to avoid unwanted windup of the integrator:

- 1) When freeze signal, `frz`, is nonzero, the input to the proportional gain is held at the previous value and the input to the integrator is set equal to 0.
- 2) The difference between the integrator output and user-set controller limit is fed back to the integrator, ensuring that the integrator value is frozen when it hits the limits.

This component is very similar to a user-defined module commonly included in PSCAD's built-in example files (but not the base component library).

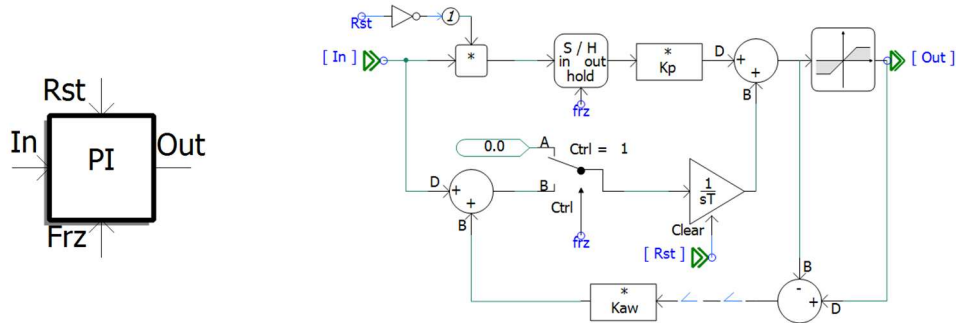

Figure 58: Icon (Left) and Main Control Diagram (Right) for PI\_AntiWindUp Component.

Table 30: Input Parameters for PI\_AntiWindUp Component.

Name	Units	Use
Maximum output limit	N/A	N/A
Minimum output limit	N/A	N/A
Proportional gain Kp	N/A	N/A
Integrator time constant	s	N/A
Anti wind-up gain	N/A	A value of 1 is desired in most cases and results in total elimination of windup when limits are hit.

### 6.19 dq-Domain Power Calculation – PQ\_dq

The PQ\_dq component implements the dq-domain equations for instantaneous real and reactive power. It can also convert the outputs to per-unit and filter them using a first order low-pass filter. The component’s purpose is to increase the organization and readability of schematics.

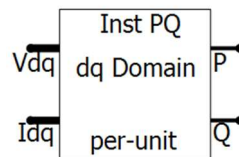

Figure 59: Icon for the PQ\_dq Component.

Table 31: Input Parameters for PQ\_dq Component.

Name	Units	Use
Filtering time constant	s	First-order low-pass filter on power calculations
Power base	MVA	Defines apparent power base. Set equal to 1 if inputs are already in per unit.

### 6.20 Per-unit Base Calculator – pu\_bases

The pu\_bases component computes base values (impedance, time, etc.) that are implicitly defined once one has defined a voltage, power, and frequency base. The component’s purpose is to improve the organization of schematics and reduce time spent troubleshooting scaling and/or per-unitization issues.

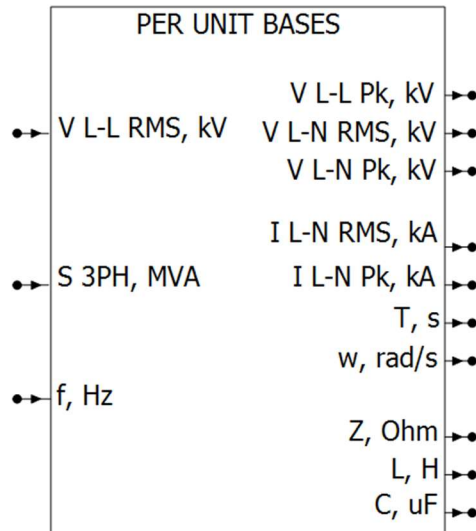

Figure 60: Icon for the `pu_bases` Component.

This component has no input parameters. The user supplies the voltage base (in kV L-L RMS), three-phase apparent power base (in MVA), and frequency base (in Hz)—all remaining bases may be derived from these. The units of output bases are shown on Figure 60 and are the default units used by PSCAD.

### 6.21 3 PH Set of 1 PH Rectifiers – `rect_3x_full_wave`

The `rect_3x_full_wave` component implements a 3 PH set of single-phase full-bridge diode rectifier loads. The rectifiers are connected line-to-line. For data center models, this component provides a simplified aggregate representation of small drive-supplied motor loads (e.g., centrifugal fans for CRAH). A series reactor, sized on a per-unit basis, is included. Small variations in load balancing are supported, but the user should manually override the capacitor values (which are balanced) if simulating large differences in the actual capacity of drives connected to a given phase.

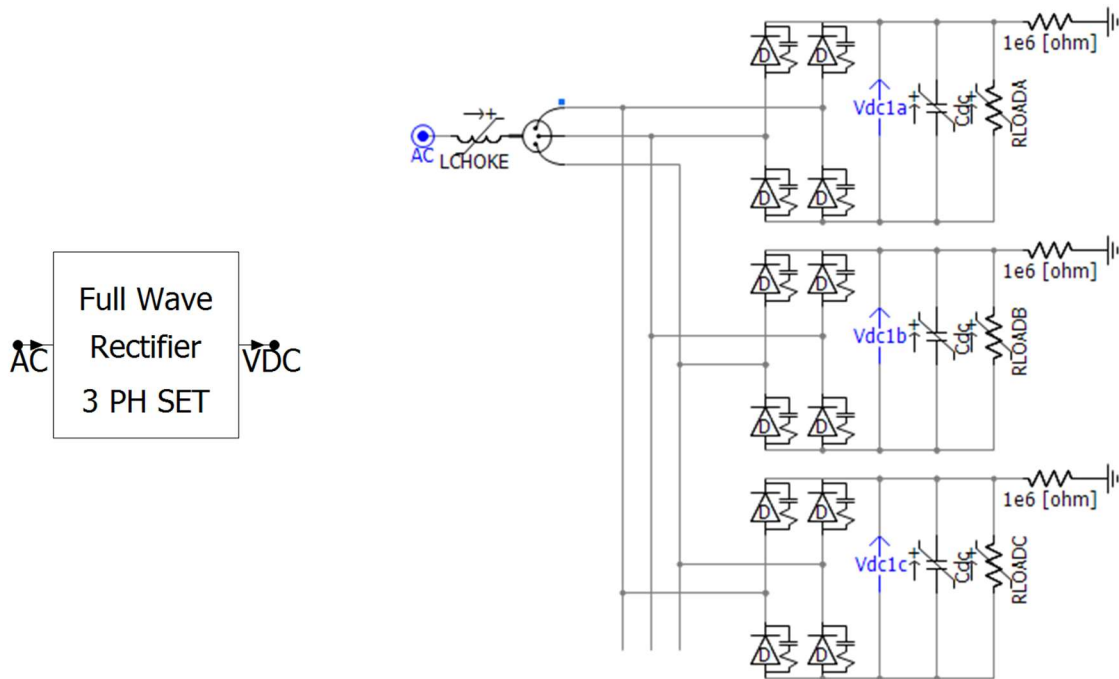

Figure 61: Icon (Left) and Electrical Schematic (Right) for `rect_3x_full_wave` Component.

Table 32 describes the input parameters for the `rect_3x_full_wave` component. To avoid needing to resize passive components, it is recommended to implement alternate power and voltage ratings using PSCAD’s built in scaling components.

Table 32: Input Parameters for `rect_3x_full_wave` Component.

Name	Units	Use
Nominal Power Consumption	MW	Based on DC side consumption—apparent power flow from harmonics not included.
Nominal L-L AC Voltage	kV RMS	Defines voltage base.
Nominal AC frequency	Hz	Defines frequency base.
Per-phase DC Link Capacitance	$\mu\text{F}$	N/A
AC Side Inductance	pu	Series reactors are commonly added to protect drives from inrush current, transient overvoltages. A value of 0.03 to 0.05 pu is typical.
Fraction of Load on AB Phases	pu	Value between 0 and 1, 0.333 typical. The fraction on CA is obtained by subtracting AB and BC fractions from one.
Fraction of Load on BC Phases	pu	

### 6.22 3 PH Set of 1 PH Rectifiers with Protection – `rect_3x_full_wave_c`

The `rect_3x_full_wave_c` component is identical to the `rect_3x_full_wave` component except in that it includes a set of single-phase contactors (`uv_sw_1PH`) which allows the component to represent per-phase tripping of small motor drives. This model introduces no new functionality over the `rect_3x_full_wave` and `uv_sw_1PH` components and is included primarily for convenience.

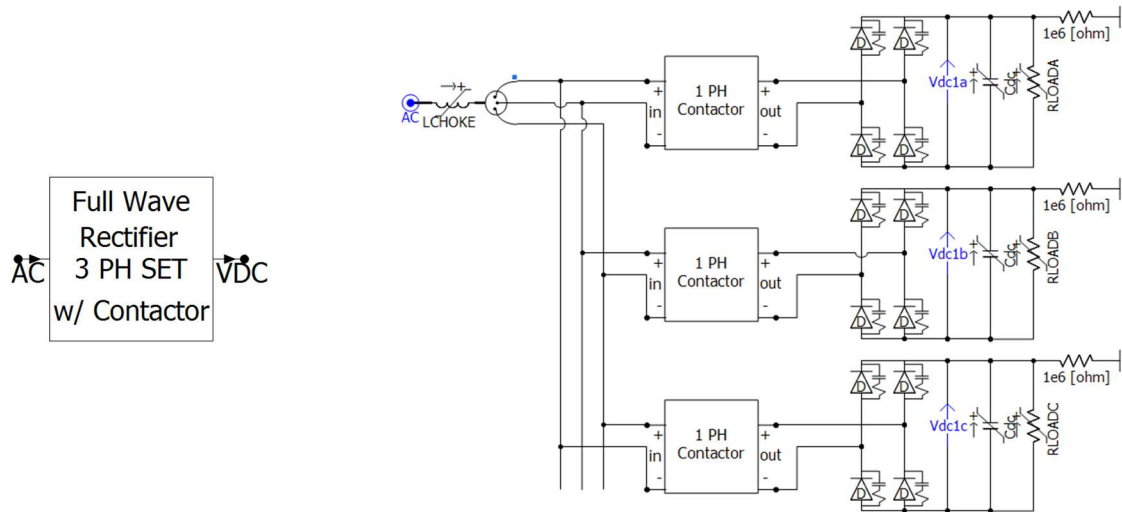

Figure 62: Icon (Left) and Electrical Schematic (Right) for `rect_3x_full_wave_c` Component.

Refer to the input tables for `rect_3x_full_wave` (Table 32) and `uv_sw_1PH` (Table 39) for explanations of the input parameters for this component.

### 6.23 3 PH Diode Rectifier – `rect_six_pulse`

The `rect_six_pulse` component implements a three-phase six-pulse rectifier. For data center models, this component provides a simplified aggregate representation of large drive-supplied motor loads (e.g., pumps for the chilled water plant). A series reactor, sized on a per-unit basis, is included.

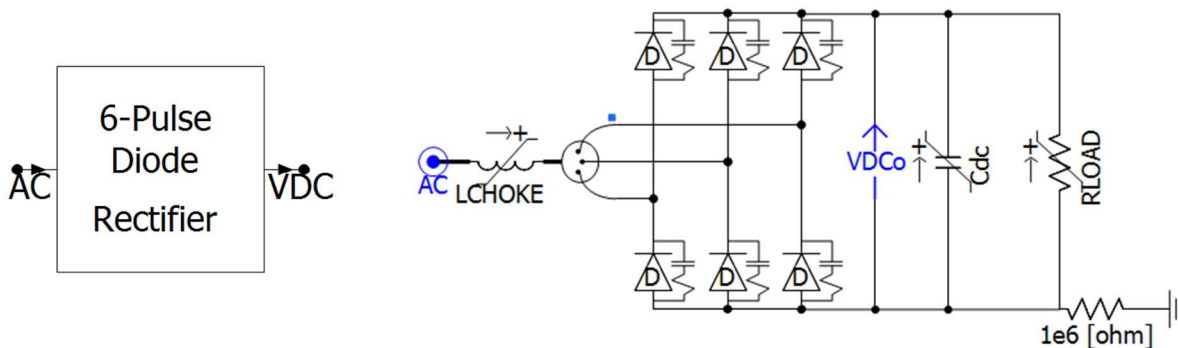

Figure 63: Icon (Left) and Electrical Schematic (Right) for `rect_six_pulse` Component.

Table 33: Input Parameters for `rect_six_pulse` Component.

Name	Units	Use
Nominal Power Consumption	MW	Based on DC side consumption—apparent power from harmonics not included.
Nominal L-L AC Voltage	kV RMS	Defines voltage base.
Nominal AC frequency	Hz	Defines frequency base.
Per-phase DC Link Capacitance	$\mu\text{F}$	N/A
AC Side Inductance	pu	Series reactors are commonly added to protect drives from inrush current, transient overvoltages. A value of 0.03 to 0.05 pu is typical.

## 6.24 Stabilizer for Droop-Based GFM Control – `stage2_illum`

The `stage2_illum` component implements a supplementary current limiting control for droop-based GFM inverters [90]. It is used as an optional feature in the `gfm_ibr_droop_swm` and `gfm_ibr_droop_avm` inverter models.

A major benefit of this control is enhancing the stability of the droop control during faults; the basic droop control (`gfm_droop`) is susceptible to losing synchronism during faults as it cannot output sufficient real power. The `stage2_illum` control accomplishes this (along with current limiting) by reducing the real and reactive power references based on the  $d$ - and  $q$ -axis overcurrents, respectively:

There are no input parameters for the `stage2_illum` component, as it is not anticipated that DML users will often need to adjust this model's parameters.

## 6.25 Unbalance Calculation – `unb_rms`

The `unb_rms` component computes voltage unbalance from a set of 3 voltage magnitudes in accordance with ANSI 47, which is commonly applied to protective relays and contactors used in industrial power systems. The input and output signals are in per unit.

## 6.26 UPS Controller – `ups_ctrl`

The `ups_ctrl` component is used for double conversion UPS modeling and is responsible for protection functions and the transferring of the UPS between different operating modes. Three operating modes are supported: normal, bypass, and battery. These are illustrated in Figure 64 and Table 34.

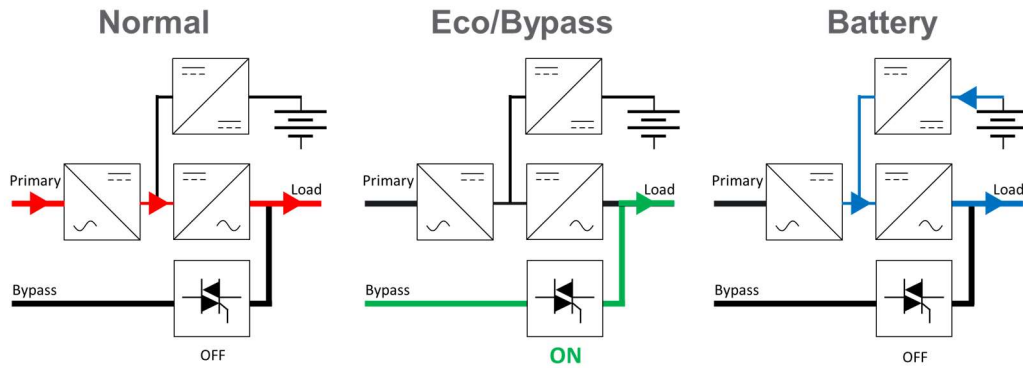

Figure 64: UPS Operating Modes and Corresponding Power Flow Paths [91].

Table 34: Correspondence of UPS Controller Operating Modes to Rectifier/Bypass Status.

Operating Mode	Rectifier Status <sup>1</sup>	Bypass Status
Normal <sup>2</sup>	On	Open
Bypass	Off	Closed
Battery	Off	Open

<sup>1</sup>This corresponds to the blocking of the rectifier IGBTs, not the opening of a mechanical switch.

<sup>2</sup>More properly, this is “double conversion” mode—the term “normal” may be more intuitive for users less familiar with UPS who need to configure the model.

Two sets of voltage-based protection functions are supported—one for the bypass mode and another for normal mode. The bypass mode protections are intended to be set far more sensitively, as the downstream load is directly connected to the grid in bypass mode. Bypass protections trip only the bypass and rectifier protections trip only the rectifier. For example, if the UPS is operating in bypass mode and the bypass protections trip, the UPS will transition to normal mode—the rectifier will remain online until the rectifier protections trip. If the rectifier protection trips as well, the rectifier will turn off as well, and the UPS will be operating in battery mode.

The `ups_ctrl` component supports auto-reconnection for the rectifier (but not the bypass) following a protection trip, but there is no synchronization or soft-start type features integrated. To simulate ramped UPS reconnection following a voltage sag, it is better to use the momentary cessation in the rectifier model (`gfl_ibr`). Future versions may include additional synchronization logic for the UPS output inverter (which needs to be synchronized with the grid side voltage prior to closing the bypass switch) so transitions to bypass mode can be simulated.

The `ups_ctrl` component does not handle LVRT functionality (i.e., rectifier controls that respond to sags in grid voltage), its only output capability is to switch the bypass and/or rectifier on or off. LVRT functions such as momentary cessation and dynamic voltage support are implemented in the rectifier (`gfl_ibr`).

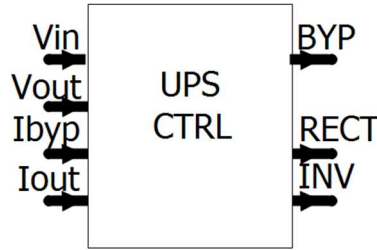

Figure 65: Icon for the ups\_ctrl Component.

Table 35, Table 36, and Table 37 describe the parameters used to configure the ups\_ctrl component.

Table 35: Rating-Related Parameters for ups\_ctrl Component.

Name	Units	Use
Nominal AC Voltage	kV L-L RMS	Defines voltage base for voltage-related protections.
Nominal Apparent Power	MVA	Defines apparent power base; not presently used.
Nominal AC Frequency	Hz	Defines frequency base; not presently used.
Initial Operating Mode	N/A	Choose one of the options described in Figure 64; Normal is the most typical state for data center UPS.
Startup Time	s	Protection functions are blocked from operating until simulation time exceeds this value.

Table 36: Bypass Control-Related Parameters for ups\_ctrl Component.

Name	Units	Use
Enable AC bypass undervoltage	Boolean	Phase undervoltage protection element: will open the bypass switch if the grid AC voltage magnitude drops below the pickup value for the set time delay.
Bypass undervoltage pickup	pu	
Bypass undervoltage time delay	s	
Enable bypass volt. unbalance?	Boolean	Phase voltage unbalance element (ANSI 47 definition); will open the bypass switch if the grid AC voltage unbalance exceeds the pickup value for the set time delay.
Bypass volt. unbalance pickup	pu	
Bypass volt. unbalance time delay	s	
Enable AC bypass overvoltage?	Boolean	Phase overvoltage protection element: will open the bypass switch if the grid AC voltage magnitude exceeds the pickup value for the set time delay.
Bypass volt. unbalance pickup	pu	
Bypass overvoltage time delay	s	

Table 37: Rectifier Protection-Related Parameters for `ups_ctrl` Component.

Name	Units	Use
Enable AC bypass undervoltage	Boolean	Undervoltage protection element: will turn off rectifier if the grid AC voltage magnitude drops below the pickup value for the set time delay.
Bypass undervoltage pickup	pu	
Bypass undervoltage time delay	s	
Enable bypass volt. unbalance?	Boolean	Voltage unbalance element (ANSI 47 definition); will turn off rectifier if the grid AC voltage unbalance exceeds the pickup value for the set time delay.
Bypass volt. unbalance pickup	pu	
Bypass volt. unbalance time delay	s	
Enable AC bypass overvoltage?	Boolean	Overvoltage protection element: will turn off rectifier if the grid AC voltage magnitude exceeds the pickup value for the set time delay.
Bypass volt. unbalance pickup	pu	
Bypass overvoltage time delay	s	
Enable auto-reconnection?	Boolean	If nonzero, the rectifier will turn back on after the set time delay so long as the undervoltage, overvoltage, or unbalance protections are not timing.
Auto-Reconnection Time Delay	s	

### 6.27 3 PH Contactor – `uv_sw`

The `uv_sw` component represents a three-pole, three-phase contactor with undervoltage and voltage unbalance protections, is commonly used to ensure proper de-energization and restart of industrial processes (e.g., cooling) in response to voltage sags and/or significant voltage unbalance.

Figure 66: Icon for the `uv_sw` Component.

Table 38: Input Parameters for `uv_sw` Component.

Name	Units	Use
Nominal AC voltage	L-L RMS	Defines line-to-line voltage base.
Protected Voltage	Boolean	Select 1 for line-to-neutral voltage, 0 for line-to-ground voltage.
Enable Voltage Unbalance Protection?	Boolean	N/A
Startup time	s	Protection is disabled until simulation time exceeds this value
Nominal frequency	Hz	Used for RMS calculation
Undervoltage trip, pickup threshold	pu	RMS undervoltage element, opens contactor if measured voltage drops below set threshold for set time period.
Undervoltage trip, pickup time	s	
Volt. Unbalance Trip, Pickup Thresh.	pu	Voltage unbalance element (ANSI 47 method): opens contactor if measured voltage unbalance exceeds set threshold for set time period.
Volt unbalance trip, pickup time	s	

### 6.28 1 PH Contactor – `uv_sw_1PH`

The `uv_sw_1PH` component represents a two-pole, single-phase contactor with an undervoltage dropout, such as is commonly used to ensure proper de-energization and restart of industrial processes (e.g., cooling) in response to voltage sags.

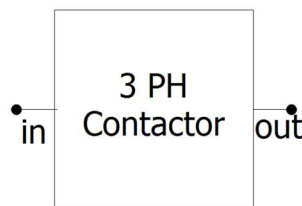
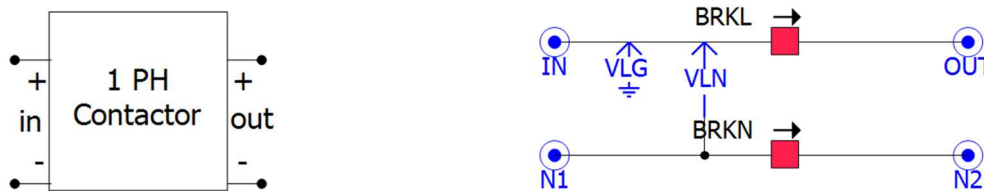

Figure 67: Icon (Left) and Electrical Schematic (Right) for `uv_sw_1PH` Component.

Table 39: Input Parameters for `uv_sw_1PH` Component.

Name	Units	Use
Nominal AC voltage	RMS	Defines voltage base used for undervoltage protection
Protected Voltage	Boolean	Select 1 for line-to-neutral voltage, 0 for line-to-ground voltage.
Startup time	s	Protection is disabled until simulation time exceeds this value
Nominal frequency	Hz	Used for RMS calculation
Undervoltage trip, pickup threshold	pu	RMS undervoltage element, opens contactor if measured voltage drops below set threshold for set time period.
Undervoltage trip, pickup time	s	

### 6.29 dq-Domain Voltage Regulator – `v_reg`

The `v_reg` component determines the current reference necessary to track a given voltage reference. This control loop is often used in multi-layer GFM controls to convert the voltage reference from an outer control loop (e.g., `gfm_droop`) to a current reference for an inner control loop (e.g., `i_reg`).

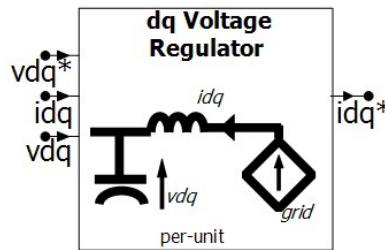

Figure 68: Icon for `v_reg`.

Table 40: Input Parameters for `i_req` Component.

Name	Units	Use
Kp, Voltage Regulator	pu	Proportional gain for PI controllers
Ti, Voltage Regulator	s	Integral time constant for PI controls
AC Side Capacitance	pu	Total shunt capacitance at node where <code>vdq</code> (see Figure 68) is measured.

## 7.0 References

- [1] "Tier Classification System," Uptime Institute, 2013. [Online]. Available: <https://uptimeinstitute.com/tiers>. [Accessed 5 November 2025].
- [2] "Capacitive Energy Storage System (CESS)," Flextronics International, 24 April 2025. [Online]. Available: <https://flex.com/resources/capacitive-energy-storage-system-cess>. [Accessed 5 November 2025].
- [3] J. Sun, M. Xu, M. Cespedes and M. Kauffman, "Data Center Power System Stability — Part I: Power Supply Impedance Modeling," *CSEE Journal of Power and Energy Systems*, vol. 8, no. 2, pp. 403-419, 2025.
- [4] J. Sun, M. Mihret, M. Cespedes, D. Wong and M. Kauffman, "Data Center Power System Stability — Part II: System Modeling and Analysis," *CSEE Journal of Power and Energy Systems*, vol. 8, no. 2, pp. 420-438, 2022.
- [5] H. Geng, *Data Center Handbook; Plan, Design, Build, and Operations of a Smart Data Center*, Hoboken, NJ: Wiley, 2021.
- [6] "Whitepaper: AI Factory 800 VDC Reference Designs," GE Vernova, 24 October 2025. [Online]. Available: <https://library.grid.governova.com/white-papers-case-studies/ai-factory-800vdc-reference-designs>. [Accessed 2025 October 2025].
- [7] "Transforming power delivery with 1 MW per IT rack," Google Cloud, 29 April 2025. [Online]. Available: <https://cloud.google.com/blog/topics/systems/enabling-1-mw-it-racks-and-liquid-cooling-at-ocp-emea-summit>. [Accessed 29 October 2025].
- [8] M. Gooding, "Microsoft and Meta reveal open AI rack design with separate power and compute cabinets," *Data Center Dynamics*, 14 November 2024. [Online]. Available: <https://www.datacenterdynamics.com/en/news/microsoft-and-meta-reveal-open-ai-rack-design-with-separate-power-and-compute-cabinets/>. [Accessed 29 October 2025].
- [9] N. Srivastava, "Building the 800 VDC Ecosystem for Efficient, Scalable AI Factories," NVIDIA, 13 October 2025. [Online]. Available: <https://developer.nvidia.com/blog/building-the-800-vdc-ecosystem-for-efficient-scalable-ai-factories/>. [Accessed 29 October 2025].
- [10] J. Huntington and M. Tu, "800 VDC Architecture for Next-Generation AI Infrastructure," NVIDIA, October 2025. [Online]. Available: <https://nvdam.nvidia.com/assets/share/asset/zlg5snufe0>. [Accessed 29 October 2025].
- [11] T. Dragičević, X. Lu, J. C. Vasquez and J. M. Guerrero, "DC Microgrids—Part II: A Review of Power Architectures, Applications, and Standardization Issues," *IEEE Transactions on Power Electronics*, vol. 31, no. 5, pp. 3528-3549, 2016.
- [12] J. Shepard, "ABB and IO to Deliver First Direct Current-Powered Data Center Module," *EE Power*, 1 November 2011. [Online]. Available: <https://eepower.com/news/abb-and-io-to-deliver-first-direct-current-powered-data-center-module/#>. [Accessed 29 October 2025].
- [13] "380 Vdc Architectures for the Modern Data Center," EMerge Alliance, 2013. [Online]. Available: <https://datacenters.lbl.gov/sites/default/files/380VdcArchitecturesfortheModernDataCenter.pdf>. [Accessed 29 October 2025].
- [14] "Heron Link: Unlocking Efficient Power Conversion for Gigascale AI," Heron Power Electronics, October 2025. [Online]. Available: <https://heronpower.com/resources/unlocking-efficient-power-conversion-for-gigascale-ai>. [Accessed 29 October 2025].
- [15] Microsoft, Meta, Google, "Diablo 400 Project: Rack and Power, Version 0.5.2," OpenCompute Project, 30 May 2025. [Online]. Available: <https://www.opencompute.org/documents/ocp-specification-diablo-400-v0p5p2-2025-05-30-pdf>. [Accessed 29 October 2025].
- [16] "Connection Requirements for Transmission-Connected Data Centres," Alberta Electric System Operator, 22 August 2025. [Online]. Available: <https://aesoengage.aeso.ca/connection-requirements-for-transmission-connected-data-centres>. [Accessed 5 November 2025].
- [17] "Revision Request 696, Integrate & Operate High Impact Large Loads," Southwest Power Pool, 3 September 2025. [Online]. Available: <https://www.spp.org/markets-operations/high-impact-large-load-hill-integration/>. [Accessed 17 November 2025].
- [18] "2800-2022 - IEEE Standard for Interconnection and Interoperability of Inverter-Based Resources (IBRs) Interconnecting with Associated Transmission Electric Power Systems," IEEE, New York, 2022.
- [19] "PRC-029-1 - Frequency and Voltage Ride-through Requirements for Inverter-based Resources," North American Electric Reliability Corporation, 8 October 2024. [Online]. Available:

- <https://www.nerc.com/globalassets/standards/approved-standards/prc/prc-029-1.pdf>. [Accessed 17 November 2025].
- [20] "What's it Like Inside STACK INFRASTRUCTURE's Newest Basis of Design Data Center?," STACK Infrastructure, 15 February 2021. [Online]. Available: <https://www.stackinfra.com/resources/thought-leadership/whats-it-like-inside-stack-infrastructures-newest-basis-of-design-data-center/>. [Accessed 28 October 2025].
- [21] "Network Data Center, a data center expansion to support network growth," EXP, [Online]. Available: <https://www.exp.com/experience/network-data-center/>. [Accessed 28 October 2025].
- [22] "Confidential Client, Utah Data Center," Skanska, 2010. [Online]. Available: <https://www.usa.skanska.com/what-we-deliver/projects/205399/Confidential-Client%2c-Utah-Data-Center/>. [Accessed 25 October 2025].
- [23] R. Miller, "Vantage Plans 1 Million SF Data Center Campus in Phoenix Market," Data Center Frontier, 8 January 2019. [Online]. Available: <https://www.datacenterfrontier.com/colocation/article/11429826/vantage-plans-1-million-sf-data-center-campus-in-phoenix-market>. [Accessed 28 October 2025].
- [24] "Characteristics and Risks of Emerging Large Loads, Large Loads Task Force White Paper," North American Electric Reliability Corporation, July 2025. [Online]. Available: [https://www.nerc.com/globalassets/who-we-are/standing-committees/rstc/3\\_doc\\_white-paper-characteristics-and-risks-of-emerging-large-loads.pdf](https://www.nerc.com/globalassets/who-we-are/standing-committees/rstc/3_doc_white-paper-characteristics-and-risks-of-emerging-large-loads.pdf). [Accessed 2 December 2025].
- [25] A. L. Isaacs, "Mitigating Risk for Large Load Interconnections," NERC, 23 June 2025. [Online]. Available: [https://www.nerc.com/comm/RSTC/LLTF/LLTF\\_Presentations\\_July\\_24\\_2025.pdf](https://www.nerc.com/comm/RSTC/LLTF/LLTF_Presentations_July_24_2025.pdf). [Accessed 29 October 2025].
- [26] Subsynchronous Resonance Working Group of the System Dynamic Performance Subcommittee, "Reader's guide to subsynchronous resonance," *IEEE Transactions on Power Systems*, vol. 7, no. 1, pp. 150-157, 1992.
- [27] M. Bahrman, E. V. Larsen, R. J. Piwko and H. S. Patel, "Experience with HVDC - Turbine-Generator Torsional Interaction at Square Butte," *IEEE Transactions on Power Apparatus and Systems*, vol. 99, no. 3, pp. 966-975, 1980.
- [28] L. Fan, R. Kavasseri, Z. L. Miao and C. Zhu, "Modeling of DFIG-Based Wind Farms for SSR Analysis," *IEEE Transactions on Power Delivery*, vol. 25, no. 4, pp. 2073-2082, 2010.
- [29] J. Zhang, J. Rose and A. Isaacs, "Investigation into Vulnerability of Synchronous Machines to Large Load Subsynchronous Active Power Variation," 24 October 2025. [Online]. Available: <https://www.ercot.com/calendar/10242025-LLWG-Meeting>. [Accessed 8 December 2025].
- [30] J. Stein, "Torsional Interaction Between Electrical Network Phenomena and Turbine-Generator Shafts," November 2006. [Online]. Available: <https://www.epri.com/research/products/1013460>. [Accessed 8 December 2025].
- [31] P. Kundur, *Power System Stability and Control*, New York: McGraw-Hill, 1994.
- [32] M. M. Islam et al, "Torsional Resonance Identification in Turbine-Generator Shaft Due to the Operation of Electric Arc Furnaces at Steel Mills in Bangladesh Power System," *IEEE Access*, vol. 11, pp. 125562-125575, 2023.
- [33] N. Liu et al, "Modular Impedance Modeling and Stability Analysis of Hybrid AC/DC Power Systems With Grid-Forming and Grid-Following Converters," *IEEE Access*, vol. 12, pp. 4063-4077, 2024.
- [34] S. Shah et al, "Impedance Methods for Analyzing Stability Impacts of Inverter-Based Resources: Stability Analysis Tools for Modern Power Systems," *IEEE Electrification Magazine*, vol. 9, no. 1, pp. 53-65, 2021.
- [35] Stability Task Force, "Diagnosis and Mitigation of Observed Oscillations in IBR-Dominant Power Systems A PRACTICAL GUIDE," Energy Systems Integration Group, August 2024. [Online]. Available: <https://www.esig.energy/wp-content/uploads/2024/08/ESIG-Oscillations-Guide-2024.pdf>. [Accessed 8 December 2025].
- [36] "Reliability Guideline, Electromagnetic Transient Modeling for BPS-Connected Inverter-Based Resources--Recommended Model Requirements and Verification Practices," North American Electric Reliability Corporation, March 2023. [Online]. Available: [https://www.nerc.com/globalassets/who-we-are/standing-committees/rstc/irps/reliability\\_guideline-emt\\_modeling\\_and\\_simulations.pdf](https://www.nerc.com/globalassets/who-we-are/standing-committees/rstc/irps/reliability_guideline-emt_modeling_and_simulations.pdf). [Accessed 9 December 2025].
- [37] "ERCOT PSCAD Model Submittal Guidelines," Electric Reliability Council of Texas, 2 July 2025. [Online]. Available: <https://www.ercot.com/services/rq/re>. [Accessed 9 December 2025].
- [38] "Load Characteristic Model: PERC1," Powerworld, October 2025. [Online]. Available: [https://www.powerworld.com/WebHelp/Content/TransientModels\\_HTML/Load%20Characteristic%20PERC1.htm](https://www.powerworld.com/WebHelp/Content/TransientModels_HTML/Load%20Characteristic%20PERC1.htm). [Accessed 9 December 2025].

- [39] L. Sundaresh and P. Mitra, "A Positive Sequence Model for Aggregated Representation Electric Vehicle Chargers," Electric Power Research Institute, November 2022. [Online]. Available: [https://certs.lbl.gov/publications/EVCharger\\_Model\\_Specifications\\_2023-Dana\\_Robson.pdf](https://certs.lbl.gov/publications/EVCharger_Model_Specifications_2023-Dana_Robson.pdf). [Accessed 9 December 2025].
- [40] "LMWG Resources, Data\_Center\_Model\_PERC1," North American Electric Reliability Corporation, December 2025. [Online]. Available: [https://dev.azure.com/nerc/\\_git/LMWG\\_Resources?path=/Data\\_Center\\_Model\\_PERC1](https://dev.azure.com/nerc/_git/LMWG_Resources?path=/Data_Center_Model_PERC1). [Accessed 10 December 2025].
- [41] North American Electric Reliability Corporation, "Inverter-Based Resource Performance Issues Report," November 2023. [Online]. Available: [https://www.nerc.com/comm/RSTC\\_Reliability\\_Guidelines/NERC\\_Inverter-Based\\_Resource\\_Performance\\_Issues\\_Public\\_Report\\_2023.pdf](https://www.nerc.com/comm/RSTC_Reliability_Guidelines/NERC_Inverter-Based_Resource_Performance_Issues_Public_Report_2023.pdf). [Accessed 4 April 2024].
- [42] "IEEE Standard 1453-2022, IEEE Standard for Measurement and Limits of Voltage Fluctuations and Associated Light Flicker on AC Power Systems," IEEE, New York, 2022.
- [43] R. C. Dugan, M. F. McGranaghan, S. Santoso and H. W. Beaty, *Electrical Power Systems Quality*, New York: McGraw-Hill, 2012.
- [44] D. Sun et al, "Open Rack V3 48V 5.5kV PSU Specification," Open Compute Project, 12 August 2023. [Online]. Available: [https://www.opencompute.org/wiki/Open\\_Rack/SpecsAndDesigns](https://www.opencompute.org/wiki/Open_Rack/SpecsAndDesigns). [Accessed 8 December 2025].
- [45] "Product brochure, Vertiv PowerUPS 9000," Vertiv, 2025. [Online]. Available: <https://www.vertiv.com/4a9f6b/globalassets/shared/vertiv-powerups-9000-brochure-en-gl-sl-71929-ul.pdf>. [Accessed 5 November 2025].
- [46] Y. Yang, K. Zhou, H. Wang and B. Frede, "Analysis and Mitigation of Dead-Time Harmonics in the Single-Phase Full-Bridge PWM Converter With Repetitive Controllers," *IEEE Transactions on Industry Applications*, vol. 54, no. 5, pp. 5343-5354, 2018.
- [47] M. Dermikol, "AI-tolerant UPSs: The first line of defense in data center resilience," Schneider Electric, 20 May 2025. [Online]. Available: <https://blog.se.com/datacenter/2025/05/20/ai-tolerant-ups-first-line-defense-data-center-resilience/>. [Accessed 8 December 2025].
- [48] "ABB launches AI-optimized 415V 3-phase UPS for large-scale data centers," ABB, 6 June 2025. [Online]. Available: <https://new.abb.com/news/detail/126439/abb-launches-ai-optimized-415v-3-phase-ups-for-large-scale-data-centers>. [Accessed 8 December 2025].
- [49] P. Shah and H. Sharma, "Interconnection and Integration of Large Loads," Southern Company, 14 November 2024. [Online]. Available: [https://www.nerc.com/globalassets/who-we-are/standing-committees/rstc/lltf/lltf\\_presentations\\_november\\_14\\_2024.pdf](https://www.nerc.com/globalassets/who-we-are/standing-committees/rstc/lltf/lltf_presentations_november_14_2024.pdf). [Accessed 9 December 2025].
- [50] "Galaxy VX 480 V UPS System Technical Specifications," Schneider Electric, July 2025. [Online]. Available: [https://www.productinfo.schneider-electric.com/galaxyvx\\_ul/5968bd3b46e0fb0001f24e08/990-5451E%20Technical%20Specifications%20480%20V/English/990-5451L\\_EN.pdf](https://www.productinfo.schneider-electric.com/galaxyvx_ul/5968bd3b46e0fb0001f24e08/990-5451E%20Technical%20Specifications%20480%20V/English/990-5451L_EN.pdf). [Accessed 5 November 2025].
- [51] "CRD-25BDA6512N-K: 25kW Bi-Directional T-Type Inverter, User Guide," Wolfspeed, October 2024. [Online]. Available: <https://www.wolfspeed.com/products/power/reference-designs/crd-25bda6512n-k/>. [Accessed 24 November 2025].
- [52] "3-Phase AC 400V Input, Vienne Rectifier PFC Power Supply Design Guide," Toshiba Electronic Devices & Storage Corporation, 26 March 2025. [Online]. Available: <https://toshiba.semicon-storage.com/us/semiconductor/design-development/referencedesign/detail.RD207.html>. [Accessed 24 November 2025].
- [53] M. Bhardwaj and C. Jiang, "Vienna Rectifier-Based, Three-Phase Power Factor Correction (PFC) Reference Design Using C2000 MCU," Texas Instruments, April 2020. [Online]. Available: <https://www.ti.com/tool/TIDM-1000>. [Accessed 24 November 2025].
- [54] M. Zhang, "How Much Does it Cost to Build a Data Center?," Dgtl Infra, 5 November 2023. [Online]. Available: <https://dgtlinfra.com/how-much-does-it-cost-to-build-a-data-center/>. [Accessed 25 November 2025].
- [55] "Open Rack/SpecsAndDesigns," OpenCompute Project, 2025. [Online]. Available: [https://www.opencompute.org/wiki/Open\\_Rack/SpecsAndDesigns](https://www.opencompute.org/wiki/Open_Rack/SpecsAndDesigns). [Accessed 5 November 2025].
- [56] L. Huber, T. Jang and M. Jovanoci, "Performance Evaluation of Bridgeless PFC Boost Rectifiers," *IEEE Transactions on Power Electronics*, vol. 23, no. 3, pp. 1381-1390, 2008.
- [57] M. Bardwaj, "Design Guide: TIDM-HV-1PH-DCAC, Voltage Source Inverter Reference Design," Texas Instruments, March 2025. [Online]. Available: <https://www.ti.com/lit/ug/tiduay6e/tiduay6e.pdf?ts=1761038254720>. [Accessed 23 October 2025].

- [58] C. Watkins, "Design Guide: TIDM-02013, 7.4-kW EV or HEV Bidirectional Onboard Charger, Reference Design With GaN," Texas Instruments, February 2024. [Online]. Available: <https://www.ti.com/lit/ug/tiduf18a/tiduf18a.pdf>. [Accessed 5 November 2025].
- [59] X. Gang and G. Wang, "TI Designs: TIDA-01604, 98.6% Efficiency, 6.6-kW Totem-Pole PFC Reference, Design for HEV/EV Onboard Charger," Texas Instruments, April 2020. [Online]. Available: <https://www.ti.com/lit/ug/tidue54b/tidue54b.pdf>. [Accessed 5 November 2025].
- [60] M. Ivankovic, "LLC Design Guide: 3300 W Converter, Simplified Algorithm Based on FHA and Vector Method," Infineon, March 2023. [Online]. Available: <https://www.infineon.com/assets/row/public/documents/24/42/infineon-llc-design-guide-3300w-converter-applicationnotes-en.pdf?fileId=8ac78c8c86919021018713adb87d42e2>. [Accessed 23 October 2025].
- [61] "Two-Phase Interleaved LLC Resonant Converter Design with C2000 Microcontrollers," Texas Instruments, March 2020. [Online]. Available: <https://www.ti.com/tool/TIDM-1001>. [Accessed 9 December 2025].
- [62] G. A. Mdiyanselage, N. Keshmiri and A. Emadi, "A Review of DC-DC Resonant Converter Topologies and Control Techniques for Electric Vehicle Applications," *IEEE Open Journal of Power Electronics*, vol. 4, pp. 945-94, 2023.
- [63] "High-Voltage to Low-Voltage DC-DC Converter Reference Design With GaN HEMT," Texas Instruments, August 2024. [Online]. Available: <https://www.ti.com/tool/PMP41078>. [Accessed 9 December 2025].
- [64] A. Samanta, S. Majumder, H. Ibrahim, P. Enjeti and L. Xie, "Electromagnetic Transient Model of Cryptocurrency Mining Loads for Low-Voltage Ride Through Assessment in Transmission Grids," in *IEEE Power and Energy Society General Meeting*, Seattle, 2024.
- [65] X. Wang et al, "Dynamic Modeling of Crypto-Miner Load in PSCAD," Electric Reliability Council of Texas, 27 October 2025. [Online]. Available: <https://www.ercot.com/about/grit/large-load-modeling>. [Accessed 24 November 2025].
- [66] "Single-Phase Battery System - A Generic Example," Manitoba Hydro International Ltd., 2018. [Online]. Available: <https://www.pscad.com/knowledge-base/article/434>. [Accessed 24 November 2025].
- [67] Y. Li and Y. Li, "AI Load Dynamics-A Power Electronics Perspective," arXiv, 6 February 2025. [Online]. Available: <https://arxiv.org/html/2502.01647v2>. [Accessed 1 December 2025].
- [68] Quanta Technology, "Evolving Load Characteristics and Reliability Considerations," North American Electric Reliability Corporation, 14 nOVEMBER 2024. [Online]. Available: [https://www.nerc.com/comm/RSTC/LLTF/LLTF\\_Presentations\\_November\\_14\\_2024.pdf](https://www.nerc.com/comm/RSTC/LLTF/LLTF_Presentations_November_14_2024.pdf). [Accessed 5 November 2025].
- [69] D. Ball, "Planning and Operating the Grid of the Future," North American Electric Reliability Corporation, 8 October 2024. [Online]. Available: [https://www.nerc.com/comm/RSTC/LLTF/LLTF\\_Kickoff\\_Presentations.pdf](https://www.nerc.com/comm/RSTC/LLTF/LLTF_Kickoff_Presentations.pdf). [Accessed 5 November 2025].
- [70] M. Sigalos and J. Smith, "Texas paid bitcoin miner Riot \$31.7 million to shut down during heat wave in August," CNBC, 6 September 2023. [Online]. Available: <https://www.cnn.com/2023/09/06/texas-paid-bitcoin-miner-riot-31point7-million-to-shut-down-in-august.html>. [Accessed 5 November 2025].
- [71] A. Springer, "Large Loads in ERCOT - Observations and Risks to Reliability," North American Electric Reliability Corporation, 8 October 2024. [Online]. Available: [https://www.nerc.com/comm/RSTC/LLTF/LLTF\\_Kickoff\\_Presentations.pdf](https://www.nerc.com/comm/RSTC/LLTF/LLTF_Kickoff_Presentations.pdf). [Accessed 5 November 2025].
- [72] P. Gravois, "ERCOT LArge Load Loss/Reduction Eventws 2020-2024," North American Electric Reliability Corporation, 12 December 2024. [Online]. Available: [https://www.nerc.com/comm/RSTC/LLTF/LLTF\\_Presentations\\_December\\_12\\_2024.pdf](https://www.nerc.com/comm/RSTC/LLTF/LLTF_Presentations_December_12_2024.pdf). [Accessed 5 November 2025].
- [73] "Incident Review, Considering Simultaneous Voltage-Sensitive Load Reductions," North American Electric Reliability Corporation, 8 January 2025. [Online]. Available: [https://www.nerc.com/pa/rrm/ea/Documents/Incident\\_Review\\_Large\\_Load\\_Loss.pdf](https://www.nerc.com/pa/rrm/ea/Documents/Incident_Review_Large_Load_Loss.pdf). [Accessed 5 November 2025].
- [74] M. Parker and B. Starling, "Dominion Energy Unplanned Data Center Load Transfer Update," North American Electric Reliability Corporation, 25 June 2025. [Online]. Available: [https://www.nerc.com/comm/RSTC/LLTF/LLTF\\_June\\_Workshop\\_Presentations.pdf](https://www.nerc.com/comm/RSTC/LLTF/LLTF_June_Workshop_Presentations.pdf). [Accessed 5 November 2025].
- [75] B. A. Ross and G. Paramo, "Fault Dynamics of Converter-Based Loads," North American Electric Reliability Corporation, 21 April 2025. [Online]. Available: [https://www.nerc.com/globalassets/who-we-are/standing-committees/rstc/lltf/lltf\\_april\\_meeting\\_\\_technical\\_workshop\\_presentations\\_.pdf](https://www.nerc.com/globalassets/who-we-are/standing-committees/rstc/lltf/lltf_april_meeting__technical_workshop_presentations_.pdf). [Accessed 2 December 2025].

- [76] "Power Loss Ride-Through in a Variable Speed Drive System," ABB, [Online]. Available: <https://new.abb.com/docs/librariesprovider87/mv-drives/power-loss-ride-through-in-a-variable-speed-drive-system.pdf>. [Accessed 9 December 2025].
- [77] C. Barthelmebs, "Liquid cooling: the future of data center architecture and operations," Data Center Dynamics, 8 December 2025. [Online]. Available: <https://www.datacenterdynamics.com/en/opinions/liquid-cooling-the-future-of-data-center-architecture-and-operations/>. [Accessed 9 December 2025].
- [78] L. Weng and G. Brockman, "Techniques for Training Large Neural Networks," OpenAI, 9 June 2022. [Online]. Available: <https://openai.com/index/techniques-for-training-large-neural-networks/>. [Accessed 2 December 2025].
- [79] Choukse et al, "Power Stabilization for AI Training Datacenters," arXiv, 2 December 2025. [Online]. Available: <https://arxiv.org/abs/2508.14318>. [Accessed 2 December 2025].
- [80] D. Dilley, "Solving AI Data Center Challenges with Agile Grid Forming BESS," EPC Power, 16 October 2025. [Online]. Available: <https://www.epcpower.com/insights/solving-ai-data-center-challenges-with-agile-grid-forming-bess>. [Accessed 2 December 2025].
- [81] "Standard 90.4-2025 - Energy Standard for Data Centers," American Society of Heating Refrigerating and Air-Conditioning Engineers, Peachtree Corners, GA, 2025.
- [82] Supermicro, "NVIDIA Blackwell HGX B200 and GB200 NVL72 Solutions," Supermicro, 2025. [Online]. Available: <https://www.supermicro.com/en/accelerators/nvidia>. [Accessed 1 October 2025].
- [83] "519-2022 IEEE Standard for Harmonic Control in Electric Power Systems," IEEE, New York, 2022.
- [84] J. Lee, "Ultracapacitor Applications for Uninterruptible Power Supplies (UPS)," Maxwell Technologies, August 2021. [Online]. Available: [https://maxwell.com/wp-content/uploads/2021/08/whitepaper\\_application\\_for\\_ups.pdf](https://maxwell.com/wp-content/uploads/2021/08/whitepaper_application_for_ups.pdf). [Accessed 1 December 2025].
- [85] "E-STATCOM for data centers," Siemens Energy, 2025. [Online]. Available: [https://p3.aprimocdn.net/siemensenergy/59ee537b-fec7-4d97-b8a4-b2c000c4147c/2025\\_04\\_09\\_ST1835a-008\\_Broschuere-E-STATCOM\\_for\\_Data\\_Centers\\_A4\\_Screen-pdf\\_Original%20file.pdf](https://p3.aprimocdn.net/siemensenergy/59ee537b-fec7-4d97-b8a4-b2c000c4147c/2025_04_09_ST1835a-008_Broschuere-E-STATCOM_for_Data_Centers_A4_Screen-pdf_Original%20file.pdf). [Accessed 1 December 2025].
- [86] S. Vennelaganti and S. Jones, "Battery Storage Applications at Data Centers," Tesla, April 2025. [Online]. Available: [https://www.nerc.com/globalassets/who-we-are/standing-committees/rstc/litf/litf\\_april\\_meeting\\_technical\\_workshop\\_presentations\\_.pdf](https://www.nerc.com/globalassets/who-we-are/standing-committees/rstc/litf/litf_april_meeting_technical_workshop_presentations_.pdf). [Accessed 9 December 2025].
- [87] D. Sun et al, "Open Rack V3 48V BBU Rev 1.4," Open Compute Project, 12 September 2023. [Online]. Available: <https://www.opencompute.org/documents/open-rack-v3-bbu-module-spec-1-4-pdf>. [Accessed 1 December 2025].
- [88] X. Lyu and D. Groß, "Grid Forming Fast Frequency Response for PMSG-Based Wind Turbines," *IEEE Transactions on Sustainable Energy*, vol. 15, no. 1, pp. 23-38, 2024.
- [89] B. A. Ross and W. Du, "An Averaged-Value Model for Voltage-Source Converters with Hysteresis-based Current Clamping," TechRxiv, 20 November 2025. [Online]. Available: [10.36227/techrxiv.176410579.96549826/v1](https://arxiv.org/abs/10.36227/techrxiv.176410579.96549826/v1). [Accessed 25 November 2025].
- [90] W. Du and S. M. Mhiuddin, "A Two-Stage Current Limiting Control Strategy for Improved Low-Voltage Ride-Through Capability of Direct-Droop-Controlled, Grid-Forming Inverters," in *IEEE Energy Conversion Congress and Exposition*, Nashville, TN, 2023.
- [91] B. A. Ross, "UPS Fault Dynamics," Electric Reliability Council of Texas, 10 July 2025. [Online]. Available: <https://www.ercot.com/calendar/07112025-LLWG-Meeting>. [Accessed 12 November 2025].
- [92] "Deploying liquid cooling in the data center, a guide to high-density cooling," Vertiv, March 2024. [Online]. Available: <https://www.vertiv.com/en-us/about/news-and-insights/articles/white-papers/how-to-implement-liquid-cooling-at-existing-data-centers>. [Accessed 28 October 2025].
- [93] J. Chou, "Scaling AI Data Center Power Delivery with Si, SiC, and GaN," Infineon, June 2025. [Online]. Available: <https://www.infineon.com/assets/row/public/documents/24/59/whitepaper-scaling-ai-data-center-power-delivery-with-si-sic-and-gan.pdf>. [Accessed 28 October 2025].
- [94] "Industry Recommendation, Large Load Interconnection, Study, Commissioning, and Operations," North American Electric Reliability Corporation, 5 November 2025. [Online]. Available: <https://www.nerc.com/pa/rrm/bpsa/Alerts%20DL/NERC%20Alert%20Level%20%20%20Large%20Loads.pdf>. [Accessed 5 November 2025].
- [95] Chetan Mishra et al, "Understanding the inception of 14.7 Hz oscillations emerging from a data center," *Sustainable Energy, Grids and Networks*, vol. 43, 2025.

# **Pacific Northwest National Laboratory**

902 Battelle Boulevard  
P.O. Box 999  
Richland, WA 99354

1-888-375-PNNL (7665)

***[www.pnnl.gov](http://www.pnnl.gov)***