



DOE/EA-1440-S-1

**FINAL SUPPLEMENT TO FINAL SITE-WIDE ENVIRONMENTAL
ASSESSMENT OF THE NATIONAL RENEWABLE ENERGY
LABORATORY'S SOUTH TABLE MOUNTAIN COMPLEX**

Proposed Construction and Operation of:

- Research Support Facilities,*
 - Infrastructure Improvements (Phase I),*
 - Upgrades to the Thermochemical User Facility and Addition of the Thermochemical Biorefinery Pilot Plant*
-

May 2008

U.S. Department of Energy
Golden Field Office
National Renewable Energy Laboratory
1617 Cole Boulevard
Golden, Colorado 80401



Department of Energy

Golden Field Office
1617 Cole Boulevard
Golden, Colorado 80401-3305

May 14, 2008

DOE/EA 1440-S-1

FINDING OF NO SIGNIFICANT IMPACT
for
SUPPLEMENT TO FINAL SITE-WIDE ENVIRONMENTAL ASSESSMENT
OF THE NATIONAL RENEWABLE ENERGY LABORATORY'S
SOUTH TABLE MOUNTAIN COMPLEX

AGENCY: Department of Energy, Golden Field Office

ACTION: Finding of No Significant Impact

SUMMARY: In accordance with the Department of Energy (DOE) National Environmental Policy Act (NEPA) implementing regulations, DOE evaluated the potential environmental impacts that would result from three actions at the National Renewable Energy Laboratory's (NREL) South Table Mountain (STM) site:

Proposed Construction and Operation of:

- Research Support Facilities (RSF),
- Infrastructure Improvements (Phase I),
- Upgrades to the Thermochemical User Facility (TCUF) and addition of the Thermochemical Biorefinery Pilot Plant (TBPP)

The decision to use federal funds for these three projects required that DOE address NEPA requirements and related environmental documentation and permitting requirements. In compliance with the NEPA (42 U.S.C. 4321) and with DOE's NEPA implementing regulations (10 CFR section 1021.330) and procedures, the supplemental environmental assessment (SEA) examines the potential environmental impacts of DOE's decision to support this Proposed Action, and also examines a No Action Alternative. Under the No Action Alternative, DOE would not fund these projects and they would not be constructed or operated.

All discussions and findings related to the Proposed Action and the No Action Alternatives are presented in the attached Final SEA and Appendices. The Final SEA is hereby incorporated by reference.

For many of the environmental resource areas assessed in the SEA, the three site projects that make up the Proposed Action would not result in either adverse or beneficial impacts because the project area and surrounding area lack sensitive receptors or resource areas that would be impacted (e.g., species of concern; on-site perennial creeks, streams, ponds, or floodplains; wetlands; low-income or minority populations; agriculturally productive soils; or high



commercial- value geologic resources). Additionally, while the proposed site expansion would place additional demands on local infrastructure such as water and electrical supplies, telecommunication systems, and sewage treatment, these demands would neither exceed existing capacities nor require upgrades or modifications to the local systems which supply the STM site. Similarly, because the construction activities would be relatively short-term and of limited scale, and the majority of the workers already exist within local communities, there would be no significant socioeconomic impacts from the proposed action. In general, routine operations of the proposed projects would have no affect on the off-site public and have no potential to affect members of populations protected by Executive Order on Environmental Justice (*E.O. 12898 Federal Actions to Address Environmental Justice in Minority Populations and Low-Income Populations (59 FR 7629)*). However, implementation of the three site projects would result in some environmental impacts.

The proposed relocation of staff from the Denver West Office Park (DWOP), on the south side of Interstate 70, to the South Table Mountain (STM) site, on the north side of I-70, would result in increased traffic at intersections near the STM site. The analyses in the SEA predict that, if not mitigated, the increased traffic would lead to an unacceptable degradation of traffic flow in the east bound lanes of the Denver West Parkway/Denver West Marriot Boulevard intersection during evening rush hours. In response to these predicted impacts, DOE and NREL have developed a Mitigation Action Plan (MAP), which stipulates the mechanisms by which traffic flows will be reduced to acceptable levels and the monitoring program which will be utilized to assure the success of the mitigating actions.

Construction of an RSF building that would be more than one or two stories high on Pad 1 would obstruct the mountain views to the west from the residences on Kendrick Street that are immediately adjacent to Pad 1. RSF construction on either Pads 2 or 3 located to the north of the Kendrick Street residences would be consistent with other STM facilities and would not obstruct the neighbors mountain view. DOE currently is not proposing permanent building construction on Pad 1. Temporary construction disturbance impacts would be consistent with those described in the SEA and would be less than significant.

Collectively, the RSF and infrastructure upgrades would result in the loss of approximately 5.9 to 6.9 hectares (15 to 17 acres) of grassland and shrubland habitat, some of which would occur in or adjacent to natural drainages, which are among the site's most productive wildlife habitats and corridors. The drainages also support the site's richest vegetation.

Construction would result in short-term (1- 2 years) increases in on-site traffic, noise, fugitive dust, auto and equipment emissions, and construction debris. The equipment and facilities that would be added to the STM site under the Proposed Action would not be unique to the site. The appearance of these facilities would in fact be similar to other buildings. As such, the addition of the RSF, TBPP, and infrastructure upgrades would add to, but would not substantially alter, the visual impact and character of the site.

The proposed actions would not result in untreated operational discharges of pollutants to surface water or groundwater. Drains would be connected to the site's existing or new stormwater and sewage lines, and all discharges to the publicly owned treatment works would meet the requirements of the Metro Wastewater Reclamation District and the Pleasant View Water and Sanitation District.

The new construction would increase the impervious surface area, which could increase quantities of stormwater conveyed off-site. Management practices, including stormwater

pollution prevention measures to minimize runoff, which could include permanent detention ponds, would be implemented during construction to minimize degradation of surface water quality due to sediment and various chemicals associated with additional vehicles and construction equipment.

The proposed developments in Zone 6 would result in unavoidable adverse impacts to historical resources. The improvements would result in the destruction of the two historic Camp George West firing lines and all or portions of a low rock wall. This unavoidable adverse impact has been mitigated through consultations with the SHPO and the preparation of Level II HABS/HAER documentation of these historical resources. Through this process the impacts have been rendered less than significant.

Under both the No Action Alternative and the Proposed Action, workers within the TCUF could be directly affected by exposures to hazardous releases, fires, or explosions under the accidents postulated in the SEA, and serious injuries could occur. However, because the operations are conducted remotely, and workers have standard procedures in place to control hazards, protective equipment, and emergency response procedures, the likelihood of a serious injury to a TCUF worker is small.

Additionally, based on the accident analyses in Appendix B, DOE and NREL acknowledge that under Option 2 for the proposed TBPP, where the reactor would not be housed in a building designed to contain potential explosions, a failure of the synthesis reactor could result in injuries or fatalities to non-involved workers if they were struck by flying fragments. Even though the probability of such an accident is “extremely remote”, such consequences are unacceptable. Therefore, this option has been eliminated from further consideration by DOE and NREL for the TBPP.

Until the final design is completed for the TBPP, DOE and NREL are unable to finalize the specific building design elements and containment structures that would mitigate the impacts of a catastrophic synthesis reactor failure accident. Prior to final design, NREL would initiate a Safety Assessment for the TBPP facility and associated activities to determine what additional levels of risk assessment are required.

Construction near the east or west boundary of Zone 6 would occur close to residences, and noise could be a nuisance for some residents during the duration of construction. Construction-related noise impacts would vary with the phase of construction and would occur intermittently. Because this noise would be short-term, mitigated by distance, occur during normal week day working hours, and would comply with all applicable noise ordinances, it would not result in a significant adverse impact. Operationally there would be no noise sources that could generate significant noise impact to off-site members of the public.

The Proposed Action would not offer any credible targets of opportunity for terrorists or saboteurs to inflict significant adverse impacts to human life, health, or safety, nor would the Proposed Action render the STM site as a whole any more susceptible to such acts. However, the consequences of an operational accident as defined in the SEA could occur if initiated by an act of terrorism or sabotage.

The Proposed Action would support and promote the overall objectives and mission of NREL and would occur within areas evaluated and committed to for further development in the 2003 site-wide EA.

COPIES OF THE FINAL SEA ARE AVAILABLE FROM:

Steve Blazek
DOE/GO NEPA Compliance Officer
U.S. Department of Energy
1617 Cole Boulevard
Golden, CO 80401
(303)275-4723
steve_blazek@go.doe.gov

FOR FURTHER INFORMATION ON THE DOE NEPA PROCESS CONTACT:

Office OF NEPA Policy and Compliance
U.S. Department of Energy
1000 Independence Avenue, S.W.
Washington, D.C. 20585
(202) 586-4600 or (800) 472-2756

DETERMINATION:

Based on the information presented in the Final SEA (DOE/EA 1440-S-1), and the commitment in the MAP to mitigate traffic impacts to less than significant levels, DOE determines that the construction and operation of RSF on pads 2 or 3; the proposed infrastructure upgrades; and the modifications to TCUF and the addition of TBPP; do not constitute major Federal actions significantly affecting the quality of the human environment, within the meaning of the National Environmental Policy Act. Therefore, the preparation of an Environmental Impact Statement is not required, and DOE is issuing this Finding of No Significant Impact.

Issued in Golden, Colorado 16th day of May, 2008.



Rita L. Wells
Manager

TABLE OF CONTENTS

ACRONYMS AND ABBREVIATIONS v

SUMMARY vii

1.0 INTRODUCTION 1

 1.1 The National Environmental Policy Act and Related Procedures 2

 1.2 Background..... 2

 1.3 Purpose and Need 3

 1.4 Scoping 6

 1.5 Draft SEA Comments 6

2.0 PROPOSED ACTION AND ALTERNATIVES 8

 2.1 Research Support Facilities..... 8

 2.2 Site Infrastructure Improvements (Phase 1 Buildout)..... 13

 2.3 Thermochemical User Facility..... 15

 2.4 No Action Alternative..... 21

 2.5 Alternatives Considered But Not Analyzed..... 21

3.0 EXISTING ENVIRONMENT AND ENVIRONMENTAL IMPACTS 23

 3.1 Environmental Impacts of the Proposed Action 23

 3.1.1 Land Use and Planning 23

 3.1.1.1 Existing Environment 23

 3.1.1.2 Impacts of the Proposed Action..... 24

 3.1.2 Traffic 25

 3.1.2.1 Existing Environment 25

 3.1.2.2 Impacts of the Proposed Action..... 29

 3.1.3 Safety and Accidents 38

 3.1.4 Visual Quality/Aesthetics 41

 3.1.4.1 Existing Environment 41

 3.1.4.2 Impacts of the Proposed Action..... 41

 3.1.5 Water Resources 48

 3.1.5.1 Existing Environment 48

 3.1.5.2 Impacts of the Proposed Action..... 48

 3.1.6 Biological Resources and Wetlands..... 49

 3.1.6.1 Existing Environment 49

 3.1.6.2 Impacts of the Proposed Action..... 51

 3.1.7 Cultural Resources 51

 3.1.7.1 Existing Environment 51

 3.1.7.2 Regulatory Background and SHPO Consultations 52

3.1.7.3	Impacts of the Proposed Action.....	53
3.1.8	Air Quality	53
3.1.8.1	Existing Environment	53
3.1.8.2	Impacts of the Proposed Action.....	54
3.1.8.3	Conformity Review	55
3.1.9	Geology and Soils.....	57
3.1.9.1	Existing Environment	57
3.1.9.2	Impacts of the Proposed Action.....	58
3.1.10	Waste Management.....	59
3.1.10.1	Existing Environment	59
3.1.10.2	Impacts of the Proposed Action.....	60
3.1.11	Noise	60
3.1.11.1	Existing Environment	60
3.1.11.2	Impacts of the Proposed Action.....	61
3.1.12	Public Services and Utilities	62
3.1.12.1	Existing Environment	62
3.1.12.2	Impacts of the Proposed Action.....	62
3.1.13	Environmental Justice.....	63
3.1.13.1	Existing Environment	63
3.1.13.2	Impacts of the Proposed Action.....	68
3.1.14	Intentional Destructive Acts	68
3.1.15	Energy Efficiency and Sustainability.....	68
3.2	Environmental Consequences of the No Action Alternative	69
4.0	CUMULATIVE AND SECONDARY IMPACTS	70
5.0	COMMITMENT OF RESOURCES AND SHORT-TERM USES	76
5.1	Irreversible/Irretrievable Commitment of Resources	76
5.2	The Relationship between Local Short-Term Uses of the Human Environment and the Maintenance and Enhancement of Long-Term Productivity	76
6.0	REFERENCES	77
APPENDIX A SCOPING LETTER AND DISTRIBUTION LISTS		A-1
APPENDIX B SAFETY AND ACCIDENT ANALYSES.....		B-1
B.1	Introduction.....	B-1
B.2	Safety Evaluation of Current TCUF Operations.....	B-4
B.2.1	Hazards of Current TCUF Operations	B-4
B.2.2	TCUF Safety Features	B-4
B.2.3	Postulated Accident Scenarios.....	B-4
B.2.4	Detailed (Bounding) Accident Analyses	B-16
B.2.5	Summary of Accident Analyses for Current TCUF.....	B-22

B.3	Safety Analysis of the Proposed TBPP and Upgrades to the TCUF.....	B-23
B.3.1	Hazards Analysis	B-23
B.3.2	Postulated TBPP Accident Scenarios	B-25
B.3.3	Detailed (Bounding) Accident Analyses	B-26
B.3.4	Summary of Accident Analyses for Proposed TBPP and TCUF Upgrades	B-29
B.4	References.....	B-29
APPENDIX C DRAFT SEA COMMENTS AND RESPONSES		C-1

LIST OF TABLES

Table 2-1.	STM Vehicle Trip Generation	12
Table 2-2.	TCUF Upgrades and TBPP Elements.....	22
Table 3-1.	Traffic Surveyed Intersections around the STM Site.....	27
Table 3-2.	LOS Criteria.....	29
Table 3-3.	Proportion of Site-Generated Traffic for Year 2010 Conditions	35
Table 3-4.	Trip Reduction Associated with Each Recommendation Group	37
Table 3-5.	TCUF/TBPP Accident Consequence Summary	39
Table 3-6.	RSF Height and Location Options	43
Table 3-7.	STM Site Estimated Annual Air Pollutant Emissions	54
Table 3-8.	Tier 1 Steady-State Emission Factors for Nonroad Diesel Engines	57
Table 3-9.	Estimated CO, NO _x , and PM Emissions from Diesel Construction Equipment	58
Table 3-10.	Hazardous Waste Generation, 2003-2007	59
Table B-1.	TCUF Hazards and Safety Controls	B-5
Table B-2.	Event Probability Classification Table	B-15
Table B-3.	Maximum Deflagration Pressures for Flammable Compounds in Air	B-17
Table B-4.	Release and Consequence Estimates for Spill of Pyrolysis Oil	B-20
Table B-5.	Potential Hazards and Installed Safeguards.....	B-24
Table B-6.	TCUF/TBPP Accident Consequence Summary	B-30

LIST OF FIGURES

Figure 1-1.	Regional Location of the STM Site	4
Figure 1-2.	Local Setting of the STM Site	5
Figure 2-1.	Current Site Layout.....	9
Figure 2-2.	Site Development Zones	10
Figure 2-3.	On-site Locations of Proposed Buildings and Upgrades	11
Figure 2-4.	TCUF Equipment and Operations	17
Figure 2-5.	Integrated TCUF/TBPP Unit Operations.....	20

Figure 3-1.	STM Site Vicinity Map.....	26
Figure 3-2.	Existing (2007) Traffic Volumes	28
Figure 3-3.	Existing (2007) Intersection Geometry and LOS	30
Figure 3-4.	Year 2010 Traffic - No Action Alternative.....	31
Figure 3-5.	Year 2010 Intersection Geometry and LOS - No Action Alternative.....	32
Figure 3-6.	Year 2010 Traffic - Proposed Action.....	33
Figure 3-7.	Year 2010 Intersection Geometry and LOS - Proposed Action.....	34
Figure 3-8.	Current View from a Location South of the STM Site	42
Figure 3-9.	Current View from a Location East of the STM Site	42
Figure 3-10.	Option A – From South	44
Figure 3-11.	Option A – From East.....	44
Figure 3-12.	Option B – From South.....	45
Figure 3-13.	Option B – From East	45
Figure 3-14.	Option C – From South.....	46
Figure 3-15.	Option D – From South	46
Figure 3-16.	Option E – From South.....	47
Figure 3-17.	Option E – From East	47
Figure 3-18.	Firing Lines and Targets on NREL’s Camp George West Property.....	52
Figure 3-19.	Minority Population by Census Blocks	64
Figure 3-20.	Median Household Income by Census Block Groups	65
Figure 3-21.	Median Household Income by Tracts Based on Jefferson County Standards	66
Figure 3-22.	Median Household Income by Census Block Groups based on Jefferson County Standards.....	67
Figure 4-1.	Conceptual Schematic of Site after Full Buildout	71
Figure 4-2.	Year 2030 Intersection Geometry and LOS - No Action Alternative.....	73
Figure 4-3.	Year 2030 Intersection Geometry and LOS - Proposed Action.....	74
Figure B-1.	Schematic of Current TCUF Processes and Flows	B-2
Figure B-2.	Block Diagram of Integrated TCUF/TBPP.....	B-3

ACRONYMS AND ABBREVIATIONS

ALOHA	Areal Locations of Hazardous Atmospheres
AM/a.m.	ante meridiem
BMP	best management practice
CCR	Code of Colorado Regulations
CDOT	Colorado Department of Transportation
CDOW	Colorado Division of Wildlife
CDPHE	Colorado Department of Public Health and Environment
CEQ	Council on Environmental Quality
CFR	Code of Federal Regulations
CO	carbon monoxide
CO ₂	carbon dioxide
CY	calendar year
dBa	A-weighted decibel
DGME	diethylene glycol monoethyl ether
DOE	U.S. Department of Energy
DRCOG	Denver Regional Council of Governments
DSA	documented safety analysis
DWOP	Denver West Office Park
EA	environmental assessment
EERE	DOE's Office of Energy Efficiency and Renewable Energy
EPA	U.S. Environmental Protection Agency
ERPG	Emergency Response Planning Guideline
FONSI	Finding of No Significant Impact
FTLB	Field Test Laboratory Building
g	gram
H ₂	hydrogen
HABS	Historic American Building Survey
HAER	Historic American Engineering Record
HAZOP	hazards and operability study
hp	horsepower
HVAC	heating, ventilation, and air conditioning
I-70	Interstate 70
kg	kilogram
LEED	Leadership in Energy and Environmental Design
lb	pound
LOS	level of service
mph	miles per hour
MSDS	Material Safety Data Sheet
NAAQS	National Ambient Air Quality Standards
NaOH	sodium hydroxide
NEPA	National Environmental Policy Act
NO ₂	nitrogen dioxide
NO _x	nitrogen oxides
NPDES	National Pollutant Discharge Elimination System
NREL	National Renewable Energy Laboratory
O ₃	ozone
OSHA	Occupational Safety and Health Act (Administration)
Pb	lead

PM/p.m.	post meridiem
PM	particulate matter
ppm	parts per million
psia	pounds per square inch absolute
psig	pounds per square inch gauge
PV	photovoltaic
RSF	Research Support Facilities
RTD	Regional Transportation District
S&TF	Science and Technology Facility
SEA	supplemental environmental assessment
SERF	Solar Energy Research Facility
SHPO	State Historic Preservation Office (Officer)
SIP	state implementation plan
SO ₂	sulfur dioxide
SOP	safe operating procedure
STM	South Table Mountain
SVOC	semivolatile organic compound
TBPP	Thermochemical Biorefinery Pilot Plant
TCUF	Thermochemical User Facility
TDM	Traffic Demand Management
TEEL	Temporary Emergency Exposure Limit
TNT	trinitrotoluene
TPY	tons per year
USFWS	U.S. Fish and Wildlife Service
VOC	volatile organic compound

SUMMARY

Introduction

The Department of Energy (DOE) is proposing an action consisting of three site development projects at the National Renewable Energy Laboratory's (NREL) South Table Mountain (STM) site at Golden, Colorado:

- Construction of the Research Support Facilities (RSF), a new office building or multi-building office complex;
- Installation of Phase 1 of planned Site Infrastructure Improvements (Phase 1 of Full Site Development);
- Upgrades to the Thermochemical User Facility (TCUF), TCUF High Bay area, and addition of the Thermochemical Biorefinery Pilot Plant (TBPP).

In accordance with DOE and National Environmental Policy Act (NEPA) implementing regulations, DOE is required to evaluate the potential environmental impacts of DOE facilities, operations, and related funding decisions. The decision to use federal funds for this Proposed Action requires that DOE address NEPA requirements and related environmental documentation and permitting requirements.

In 2003, DOE issued the *Final Site-Wide EA of the National Renewable Energy Laboratory's South Table Mountain Complex* and a Finding of No Significant Impact (FONSI) for the proposed site development activities (DOE/EA-1440) (DOE 2003). In compliance with the NEPA (42 U.S.C. 4321) and with DOE's NEPA implementing regulations (10 CFR section 1021.314) and procedures, DOE is examining the potential environmental impacts of the Proposed Action described above as a final Supplemental Environmental Assessment (final SEA) to the 2003 site-wide EA. The Proposed Action that is the topic of this final SEA would be implemented in areas that were analyzed in the 2003 site-wide EA. A No Action Alternative is also examined. The site-wide EA provides the analytical structure to assess the potential environmental impacts of the Proposed Action that is the topic of this final SEA. The site-wide EA is incorporated in its entirety into this final SEA by reference, and to the fullest extent possible this final SEA tiers off the descriptions of the affected environment and the potential environmental impact assessments presented in the site-wide EA.

Also, in July 2007, DOE issued a *Final Environmental Assessment of Three Site Development Projects at the National Renewable Energy Laboratory South Table Mountain Site* and FONSI (DOE/EA 1573) (DOE 2007). This EA also tiered off the 2003 site-wide EA and, for some resource areas, provided updated descriptions of the existing environment at the STM site and impacts expected from three proposed projects. That 2007 EA is also incorporated in its entirety into this final SEA by reference. Both the 2003 site-wide EA and the July 2007 EA are available at the NREL Visitors Center and at the DOE Golden Field Office Public Reading Room website at: http://www.eere.energy.gov/golden/reading_room.aspx.

This final SEA has been prepared under DOE's regulations and guidelines for compliance with NEPA. It was distributed in draft form to interested members of the public and to federal, state, and local agencies for review and comment prior to DOE's final decision on the Proposed Action. Comments received on the draft SEA and DOE's responses are provided in Appendix C.

Purpose and Need

The purpose of this supplement to the site-wide EA is to assess the individual and cumulative potential effects of the Proposed Action to determine if they would pose a significant impact to the human environment.

The purpose and need for the Proposed Action is to (1) allow DOE to relocate research and research support staff that currently work in leased off-site offices into an on-site facility, where they would be co-located with other NREL staff; (2) provide the site infrastructure necessary to support the proposed RSF, prepare the site for planned future development activities, and improve the current site drainage and stormwater detention infrastructure; and (3) provide additional research and development capabilities to promote the development of cost-competitive biofuels and to accelerate progress towards achieving DOE's 2012 target of demonstrating an integrated lignocellulosic biomass-to-ethanol process.

Proposed Action and Alternatives

Under the Proposed Action, three site development construction projects would be implemented:

Research Support Facilities

Construct the RSF, which would be a single office building or a multi-building complex that would provide approximately 20,500 to 28,000 square meters (220,000 to 300,000 square feet) of office space to accommodate up to approximately 800 research and support staff who currently work in leased off-site offices.

Site Infrastructure Improvements

Improve site infrastructure to support the proposed RSF and planned future site developments. The improvements would include construction of new on-site paved road segments; several new surface parking lots that would provide approximately 700 to 900 parking spaces; shuttle bus/tramway service to and from the new parking lots; buried water, sewer, power, and telecommunications lines; new heating, ventilation, and air conditioning (HVAC) elements; new drainage and stormwater detention basins; and open space landscaping, pedestrian walkways, and bike paths.

Thermochemical User Facility Upgrade and the Thermochemical Biorefinery Pilot Plant

Upgrading the capabilities of the TCUF is anticipated to be completed in two phases. The components of each phase may vary, depending on funding availability, but anticipated activities associated with each phase are as follows. During Phase 1, approximately 75 to 140 square meters (800 to 1,500 square feet) of specially designed, high-pressure flammable-liquid-rated, high bay space would be constructed either in or adjacent to the Field Test Laboratory Building (FTLB) as the TBPP. This new space would house pilot-scale equipment to demonstrate fully integrated biomass gasification, syngas cleanup, and ethanol synthesis. Several unit operations, including gas compression, acid gas removal, fuel synthesis, and fuel distillation, would be designed and procured during this phase. The new TBPP operations would be structurally isolated from the FTLB for fire safety reasons and would incorporate building overpressure protection. Controls would be incorporated to restrict personnel access.

Phase 2 would involve removal of surplus equipment, and laboratory space within the FTLB high bay would be removed or modified to accommodate the construction of approximately 53 square meters (575 square feet) of low bay laboratory space for mini-pilot scale experiments. Approximately 26 square

meters (275 square feet) of existing control room space would be remodeled or reconfigured to support the additional laboratories. These additional control rooms would be located within the high bay space of the TCUF. Design and construction of up to four mini-pilot scale thermochemical conversion systems would also be completed during this phase of the project. These systems would occupy the low bay laboratories described above.

No Action Alternative

The three proposed projects would not be implemented and the STM site would remain in its current configuration. The No Action Alternative would not preclude other development projects from being proposed at such time as NREL determined them to be ready for NEPA action.

Scoping

On September 12, 2007, DOE distributed a scoping/consultation letter to the public and to county, state, and federal agencies and other organizations requesting public and agency comments on the Proposed Action (Appendix A). The scoping/consultation letter was also posted on the DOE Golden Field Office Public Reading Room website:

http://www.eere.energy.gov/golden/PDFs/ReadingRoom/NEPA/Request_for_Comments_9-11-07.pdf

DOE did not receive any comments in response to the scoping/consultation letter.

Draft SEA Comments

DOE received comments from the public on the draft SEA; these comments are summarized and responded to in Appendix C of the SEA. DOE considered these comments when preparing the final SEA; however, no changes to the impact analyses were needed as a result of comments.

Environmental Consequences

This final SEA considers the following environmental resource or impact areas:

- Land Use and Planning
- Traffic
- Safety and Accidents
- Visual Quality/Aesthetics
- Water Resources
- Biological Resources and Wetlands
- Cultural Resources
- Air Quality
- Geology and Soils
- Waste Management
- Noise
- Public Services and Utilities
- Environmental Justice
- Intentional Destructive Acts
- Energy Efficiency and Sustainability

For many of the environmental resource areas assessed in this final SEA, the three site improvement projects that make up the Proposed Action would not result in impacts, either adverse or beneficial, because the project area and surrounding area lack sensitive receptors or resource areas that would be impacted (e.g., there are no species of concern; on-site perennial creeks, streams, ponds, or floodplains; jurisdictional wetlands; disproportionately impacted low-income or minority populations; agriculturally productive soils; or high commercial- or aesthetic-value geologic resources). However, implementation of the Proposed Action would result in some environmental impacts to area traffic flow, land use on the STM site, historical resources, and the visual appearance of the STM site.

Traffic

The impact analyses demonstrate that without mitigation, the increase in staffing levels proposed for the STM site would cause the unacceptable degradation of traffic flow at some intersections near the site. As a result, DOE and NREL are committed to taking both near-term and longer-term mitigation measures to prevent unacceptable traffic impacts from the actions assessed in this final SEA and from planned future expansion of the STM site.

In the near term, mitigation actions would include expanded use of the two existing STM site entrances; the implementation of traffic demand measures such as flex-time, car and vans pools, and other measures that would effectively reduce the number of vehicles accessing the site on any given day; and the investigation and development, if feasible, of off-site parking options and subsequent bussing of staff onto the STM site. Based on the traffic study and traffic mitigation planning, these measures would prevent unacceptable degradation of traffic flow in the area caused by the Proposed Action.

In the longer term, to adequately mitigate the traffic impacts from the foreseeable increases in staff at the STM site from planned site buildout, DOE and NREL would solicit funding for improvements to the Denver West Parkway/Denver West Marriott Boulevard intersection and pursue a third site entrance from South Golden Road if future growth warranted such actions.

Land Use

The Proposed Action would result in the conversion of some currently undeveloped areas within the STM site's development zones to office and laboratory space, parking lots, and site roads. This development would occur within areas identified in the final site-wide EA as acceptable for future development. However, the Proposed Action would eliminate up to 7 hectares (17 acres) of mixed grassland habitat and its use by wildlife. An additional 1.2 hectares (3 acres) of habitat would be lost for up to 2 years for the RSF construction access road. This loss would be temporary as the area would be reclaimed as habitat through recontouring and reseeded. Recognizing this potential for biotic impacts from site buildout, in 1999, DOE committed to setting aside 72 hectares (177 acres) of the site as a preserve for the conservation of prairie grasses and associated habitats.

Historical Resources

The Proposed Action would result in unavoidable adverse impacts to historical resources, specifically the destruction of the two firing lines and all or portions of the low rock wall at NREL's 10-hectare (25-acre) Camp George West Property. This unavoidable adverse impact has been mitigated through consultations with the State Historic Preservation Officer (SHPO) and by detailed documentation of these historical resources.

Visual Quality

Although a conceptual design does not exist for the RSF, DOE and NREL are committed to building a structure that is visually consistent with the existing STM facilities. As demonstrated by visual simulations in the final SEA, the RSF would visually blend in with the existing STM buildings when viewed from off-site locations. The analyses also demonstrate that construction of a multi-story RSF building on Building Pad 1 would block the view of the foothills for some residents of Kendrick Street, the neighborhood immediately south of Denver West Parkway and east of the STM site.

Review of Draft SEA

DOE and NREL have considered the analyses in the draft SEA and public and agency comments prior to finalizing this SEA. Based on these considerations, DOE has determined that a FONSI is warranted. The FONSI is attached to this final SEA.

1.0 INTRODUCTION

Introduction

The Department of Energy (DOE) is proposing an action consisting of three site development projects at the National Renewable Energy Laboratory's (NREL) South Table Mountain (STM) site at Golden, Colorado:

- Construction of the Research Support Facilities (RSF), a new office building or multi-building office complex;
- Installation of Phase 1 of planned site infrastructure improvements (Phase 1 of Full Site Development);
- Upgrades to the Thermochemical User Facility (TCUF) and the addition of the Thermochemical Biorefinery Pilot Plant (TBPP).

In accordance with DOE and National Environmental Policy Act (NEPA) implementing regulations, DOE is required to evaluate the potential environmental impacts of DOE facilities, operations, and related funding decisions. The decision to use federal funds for this Proposed Action requires that DOE address NEPA requirements and related environmental documentation and permitting requirements.

In 2003, DOE issued the *Final Site-Wide EA of the National Renewable Energy Laboratory's South Table Mountain Complex* and a Finding of No Significant Impact (FONSI) for the proposed site development activities (DOE/EA-1440) (DOE 2003). In compliance with the NEPA (42 U.S.C. 4321) and with DOE's NEPA implementing regulations (10 CFR section 1021.314) and procedures, DOE is examining the potential environmental impacts of the Proposed Action described above as a final Supplemental Environmental Assessment (final SEA) to the 2003 site-wide EA. The Proposed Action that is the topic of this final SEA would be implemented in areas that were analyzed in the 2003 site-wide EA. A No Action Alternative is also examined. The site-wide EA provides the analytical structure to assess the potential environmental impacts of the Proposed Action that is the topic of this final SEA. The site-wide EA is incorporated in its entirety into this final SEA by reference, and to the fullest extent possible this final SEA tiers off the descriptions of the affected environment and the potential environmental impact assessments presented in the site-wide EA.

Also, in July 2007, DOE issued the *Final Environmental Assessment of Three Site Development Projects at the National Renewable Energy Laboratory South Table Mountain Site* and a FONSI (DOE/EA-1573) (DOE 2007). This EA also tiered off the 2003 site-wide EA and, for some resource areas, provided updated descriptions of the existing environment at the STM site and impacts expected from three proposed projects. DOE/EA 1573 is also incorporated in its entirety into this final SEA by reference. Both the 2003 site-wide EA and the July 2007 EA are available at the NREL Visitors Center and at the DOE Golden Field Office Public Reading Room website at http://www.eere.energy.gov/golden/reading_room.aspx.

This final SEA has been prepared under DOE's regulations and guidelines for compliance with NEPA. The draft SEA was distributed to interested members of the public and to federal, state, and local agencies for review and comment prior to DOE's final decision on the Proposed Action. Comments received on the draft SEA and DOE's responses are provided in Appendix C.

1.1 The National Environmental Policy Act and Related Procedures

The Council on Environmental Quality (CEQ) regulations for implementing the procedural provisions of NEPA (40 CFR Parts 1500-1508) and DOE's implementing procedures for compliance with NEPA (10 CFR Part 1021) require that DOE, as a federal agency:

- assess the environmental impacts of its proposed actions;
- identify any adverse environmental effects that cannot be avoided should a proposed action be implemented;
- evaluate alternatives to the proposed action, including a "no action alternative";
- describe the relationship between local short-term uses of the environment and the maintenance and enhancement of long-term productivity; and
- characterize any irreversible and irretrievable commitments of resources that would be involved should the proposed action be implemented.

These requirements must be met before a final decision is made to proceed with any proposed federal action that could cause significant impacts to human health or the environment. This final SEA is intended to meet DOE's regulatory requirements under NEPA and to provide DOE, the State of Colorado, and other agency decision-makers with the information they need to make informed decisions in connection with this Proposed Action.

1.2 Background

NREL History and Research Mission

In July 1977, DOE opened the Solar Energy Research Institute as a federal facility dedicated to harnessing solar power. In 1991, it achieved national laboratory status and was renamed the National Renewable Energy Laboratory (NREL). Today, NREL is one of 10 DOE national laboratories and is the nation's primary laboratory for renewable energy and energy efficiency research and development. NREL's mission is focused on advancing national energy policy and efficiency goals, particularly in the areas of renewable, wind, and solar energy research, development, demonstration, and deployment. NREL conducts research activities at the STM site in support of the following DOE research programs:

- Solar energy technologies;
- Geothermal technologies;
- Distributed energy, electrical infrastructure, and reliability;
- Biomass;
- Industrial technologies;
- Freedom car and vehicle technology;
- Hydrogen, fuel cell, and infrastructure technologies;
- Buildings technologies;
- Weatherization and intergovernmental grants;
- Federal energy management;
- Other DOE-sponsored programs;
- Work for others supporting the DOE mission.

NREL is operated for DOE through a partnership between Midwest Research Institute and the Battelle Memorial Institute. The laboratory comprises three main sites: STM; the adjacent Denver West Office Park (DWOP) in Golden; and the National Wind Technology Center located just south of Boulder, Colorado. The STM and DWOP sites are collectively referred to as the STM complex. The three site development projects that make up the Proposed Action and are the subject of this final SEA would be implemented at the STM site. Figures 1-1 and 1-2 illustrate the regional location and local setting of the STM site and the Proposed Action.

1.3 Purpose and Need

The purpose of the Proposed Action is to support and advance DOE's mission in the research and development of energy efficiency and renewable energy technologies. DOE's Office of Energy Efficiency and Renewable Energy (EERE) leads the national research effort to develop clean, competitive, and reliable energy technologies for the 21st century. The goal of the EERE program is to improve the nation's overall economic strength and competitiveness, energy security, and environmental stewardship through the development, demonstration, and deployment of clean, competitive, and reliable power technologies. The three STM site development projects that make up the Proposed Action would contribute to achieving this goal.

Final Supplemental Environmental Assessment

The purpose of this final SEA is to assess the individual and cumulative potential effects of the three projects that make up the Proposed Action to determine if they would pose a significant impact to the human environment. The 2003 site-wide EA addressed future site developments, improvements, and on-site activities at the STM complex and future changes associated with the STM site boundaries. It acknowledged that final designs and locations of some proposed or conceptual projects or facilities at the complex were uncertain and that various configurations were possible. The site-wide EA was prepared as a "bounding" analysis that would allow for future flexibility in implementing a range of potential activities. The bounding approach was used to evaluate potential environmental impacts resulting from an array of potential development options within a conceptually defined "buildout" scenario. The assessment considered a range of future site use and development options through 2008. In the FONSI, DOE determined that the proposed or contemplated improvements assessed in the site-wide EA did not, either individually or collectively, constitute a major federal action significantly affecting the human environment within the meaning of NEPA.

The site-wide EA analyzed impacts that would occur if site development occurred in areas that DOE believed would minimize the overall environmental impacts associated with sustainable site development. Moreover, it identified areas that should be set aside and preserved in a natural or existing state. The site-wide EA assessed specific activities or improvements proposed for implementation at specific site locations or areas. Each of the three proposed projects that are the topic of this final SEA are improvements of the type that were analyzed in the site-wide EA and would occur in areas that were analyzed in the site-wide EA. DOE concluded that development in these areas would not constitute a major federal action significantly affecting the quality of the human environment. This final SEA will determine if the details of the Proposed Action remain consistent with the FONSI issued for the 2003 site-wide EA.

DOE is also considering several other site development projects, based on the availability of future funding and project-specific schedules. Those projects are not yet ready for more detailed NEPA review. Nonetheless, to the extent that they can be addressed at this time, they have been included under the analyses of cumulative impacts in accordance with CEQ and DOE regulations.

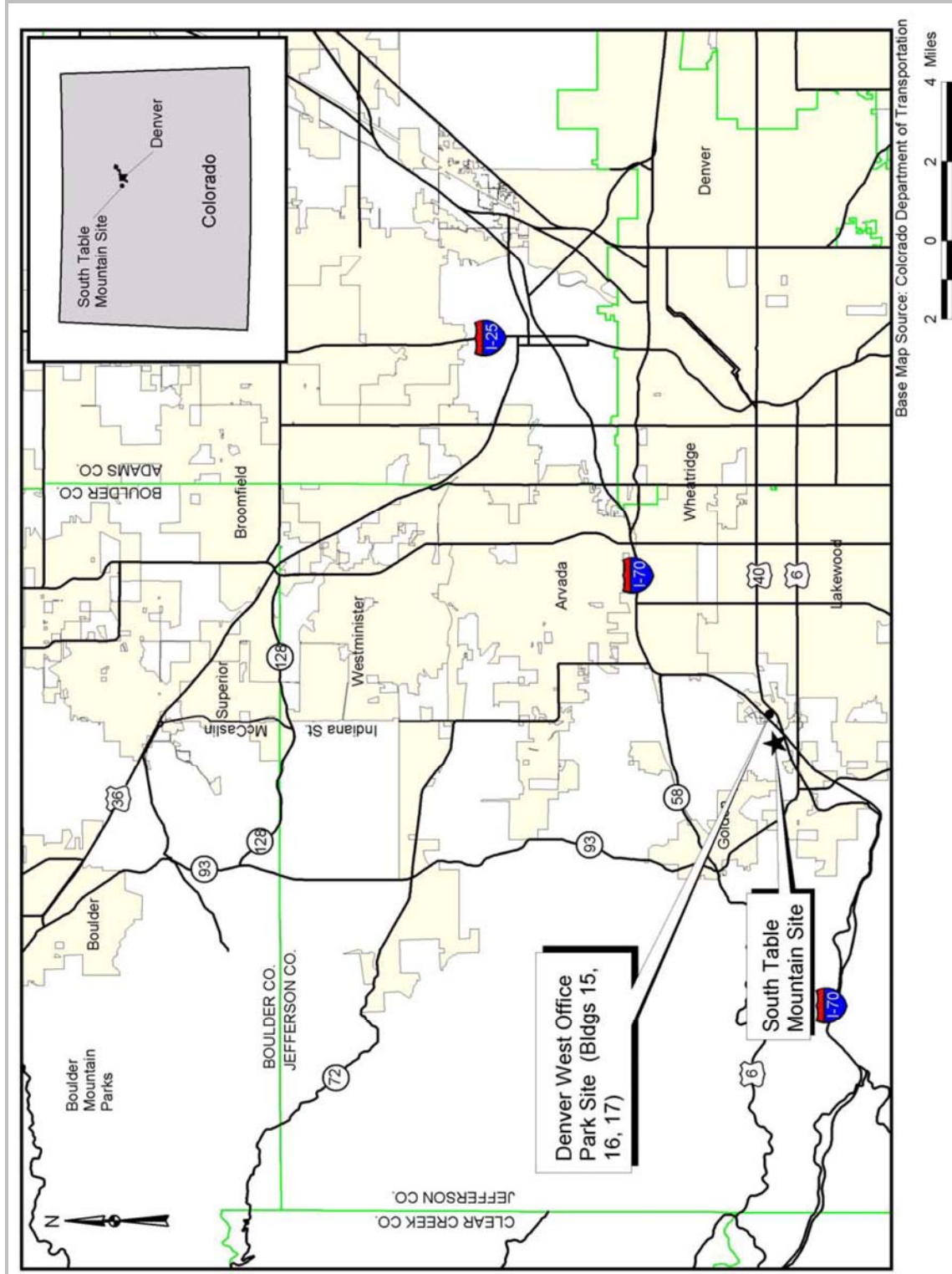

Figure 1-1. Regional Location of the STM Site

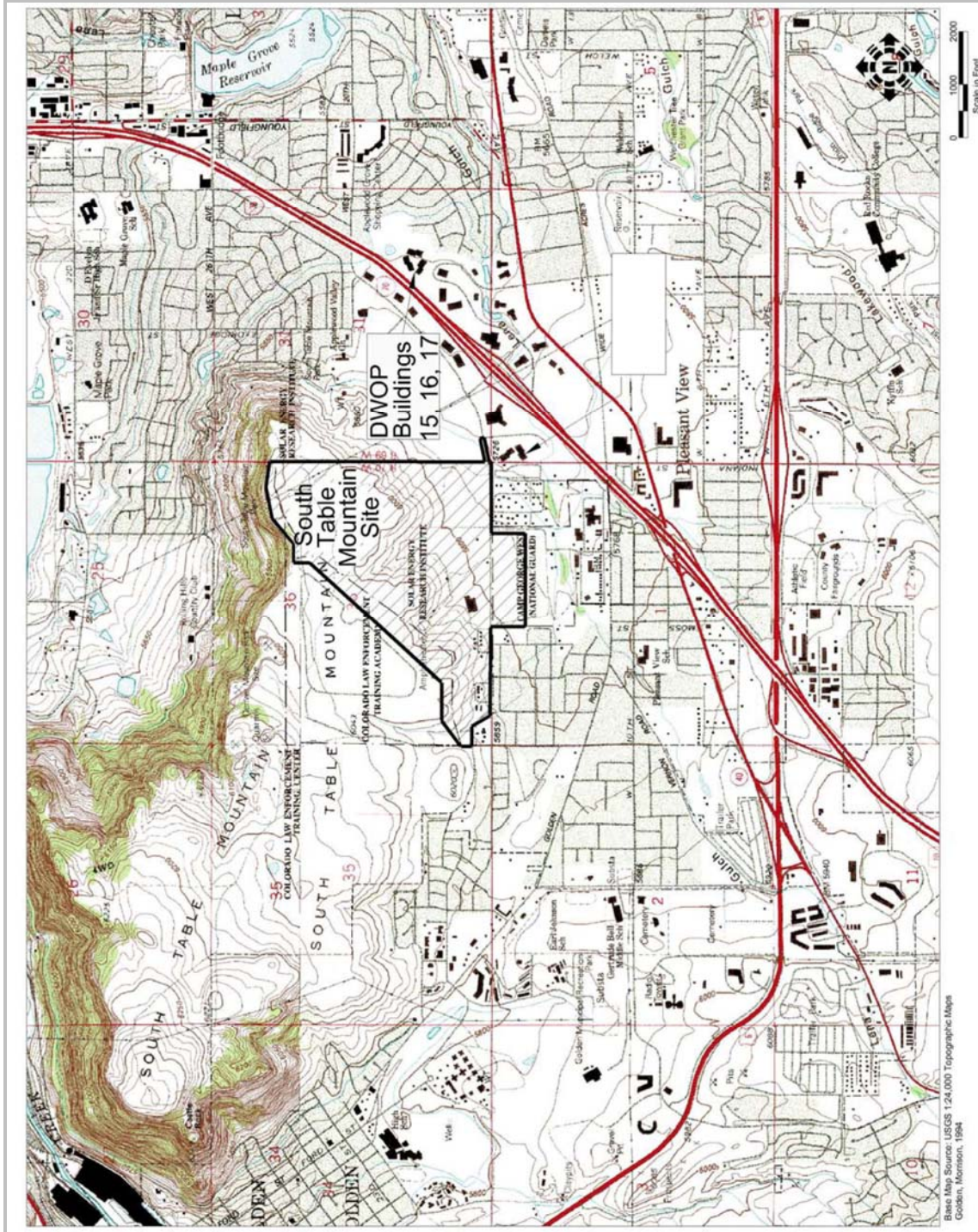

Figure 1-2. Local Setting of the STM Site

Proposed Action

Research Support Facilities. Construction of the RSF would allow DOE to relocate research and research support staff who currently work in leased, off-site offices into an on-site facility, where they would be co-located with other NREL staff. The RSF would house up to approximately 800 workers. In addition to providing more economical and consolidated on-site office and research support space, such as a library and data center, the RSF would be a showcase of sustainable, high-performance office building design. The proposed facility would demonstrate the integration of high-performance building design, construction, and operation. It would also showcase recent advances in renewable and energy-efficient building technologies. In addition to office and research support space, it would also provide needed service areas and conference rooms, a food service area, fitness areas, and a loading dock. The RSF would result in substantial savings of federal funds by largely eliminating the need for NREL staff to be housed in increasingly expensive leased off-site space.

Site Infrastructure Improvements. The proposed site infrastructure improvements would enhance the current site infrastructure, such as roads; parking areas; site drainage, stormwater detention, electric power; water and sewer lines; heating, ventilation, and air conditioning (HVAC) systems; telecommunication systems; landscaping; and other amenities. These improvements are needed to support the proposed RSF and to prepare the site for planned future development activities

TCUF Upgrade and TBPP Addition. The TCUF upgrade and TBPP addition would provide additional research and development capabilities to promote the development of cost-competitive biofuels and to accelerate progress towards achieving DOE's 2012 target of demonstrating an integrated biomass-to-ethanol process. This upgrade and the addition of the TBPP are needed to advance and expedite the breakthrough technologies that would make cellulosic ethanol cost-competitive with corn-based ethanol by 2012. The existing TCUF, which is located within the Field Test Laboratory Building (FTLB), has evolved continuously in the 13 years since the first components were installed. It has reached a state of operation that makes it a valuable and versatile research tool instead of simply being a promising research project. The proposed upgrade and TBPP addition are needed to address critical components of DOE's expanded biofuels research and development program, specifically lignocellulosic ethanol.

1.4 Scoping

On September 12, 2007, DOE distributed a scoping and consultation letter to the public and to county, state, and federal agencies and other organizations requesting public and agency comments on the Proposed Action. The scoping/consultation letter was also posted on the DOE Golden Field Office Public Reading Room website (http://www.eere.energy.gov/golden/PDFs/ReadingRoom/NEPA/Request_for_Comments_9-11-07.pdf).

The scoping/consultation letter and mailing list are shown in Appendix A. DOE did not receive any comments in response to the scoping/consultation letter.

1.5 Draft SEA Comments

DOE received several comment letters on the draft SEA. Commentors expressed concerns over the impacts from increased traffic, noise, and buildings that would obstruct mountain views; took issue with the duration of the public comment periods and the distribution of notices; challenged the economics of new office construction and the impacts on vacated space; suggested alternative designs; and stated that they had not been afforded the opportunity to participate in the decision-making on the land transfer of

Camp George West lands to NREL. DOE has reviewed these and all other comments and has summarized and responded to them in Appendix C.

2.0 PROPOSED ACTION AND ALTERNATIVES

Figure 2-1 illustrates the overall current STM site layout, and Figure 2-2 illustrates the seven development zones DOE has established on the STM site for the management of ongoing and future site land use and development. The development zones are also illustrated and described in Section 2 of the site-wide EA (DOE 2003).

DOE and NREL have developed a long-term site buildout vision for NREL designed to strengthen and expand the laboratory's capabilities, campus, and infrastructure in an orderly, phased manner. The phasing of the planned development is based on the anticipated and actual availability of facility funding. This vision is presented in two recent reports which are incorporated into this final SEA by reference: *National Renewable Energy Laboratory Ten-Year Site Plan FY2007-FY2018* (NREL 2006a) and the *Project Report for the South Table Mountain Grand Buildout Infrastructure Plan* (NREL 2007a). The Proposed Action, described in Sections 2.1 through 2.3, represents incremental implementation of the vision articulated in these two strategic planning documents.

2.1 Research Support Facilities

The proposed RSF would be an on-site office building or multi-building office complex. Figure 2-3 shows the possible locations for the RSF in Zone 4 and/or the northeast quadrant of Zone 6 south of Denver West Parkway. The figure also illustrates the three building pads on which the RSF may be constructed. Each building pad is approximately 4,650 square meters (50,000 square feet, or just over 1 acre.) DOE would prefer to construct the RSF on Building Pads 2 and/or 3 in Zone 4 rather than on Building Pad 1 in Zone 6; however, the RSF could be built on any or all of the three building pads shown in Figure 2-3.

Regardless of ultimate location, no RSF building would exceed five stories, or about 23 meters (75 feet) above grade. However, there could be one or more one- to five-story buildings on any or all of the three building pads. The total RSF facility footprint would depend on the final number of buildings constructed and their heights. (Taller buildings would result in a smaller overall RSF building footprint.) The permanent RSF building(s) footprint could cover up to the total area of the three building pads, or approximately 1.4 hectares (3.5 acres). Additional permanent footprint for walkways, patios, bike paths, and other new common areas and amenities associated with the RSF could cover up to approximately 9,300 square meters (100,000 square feet, or about 2.3 additional acres). The final facility footprint could reflect one single RSF building or several buildings. (Visual simulations of various RSF building options are provided in Section 3.1.4, Visual Quality/Aesthetics). In addition, up to several acres would be used temporarily for building laydown and staging. These areas would be reclaimed and restored after completion of the Proposed Action

Regardless of the number of buildings that would be constructed, the RSF would provide approximately 20,500 to 28,000 square meters (220,000 to 300,000 square feet) of office and research support space. It would house up to approximately 800 staff currently housed in leased, off-campus offices. In addition to offices, it would include specialty spaces such meeting and conference rooms, a library, a food service area, fitness areas, and a data center. The size, types, and designs of the specialty spaces would be finalized during the programming phase of conceptual design. Construction would be planned for the 2008-2010 timeframe.

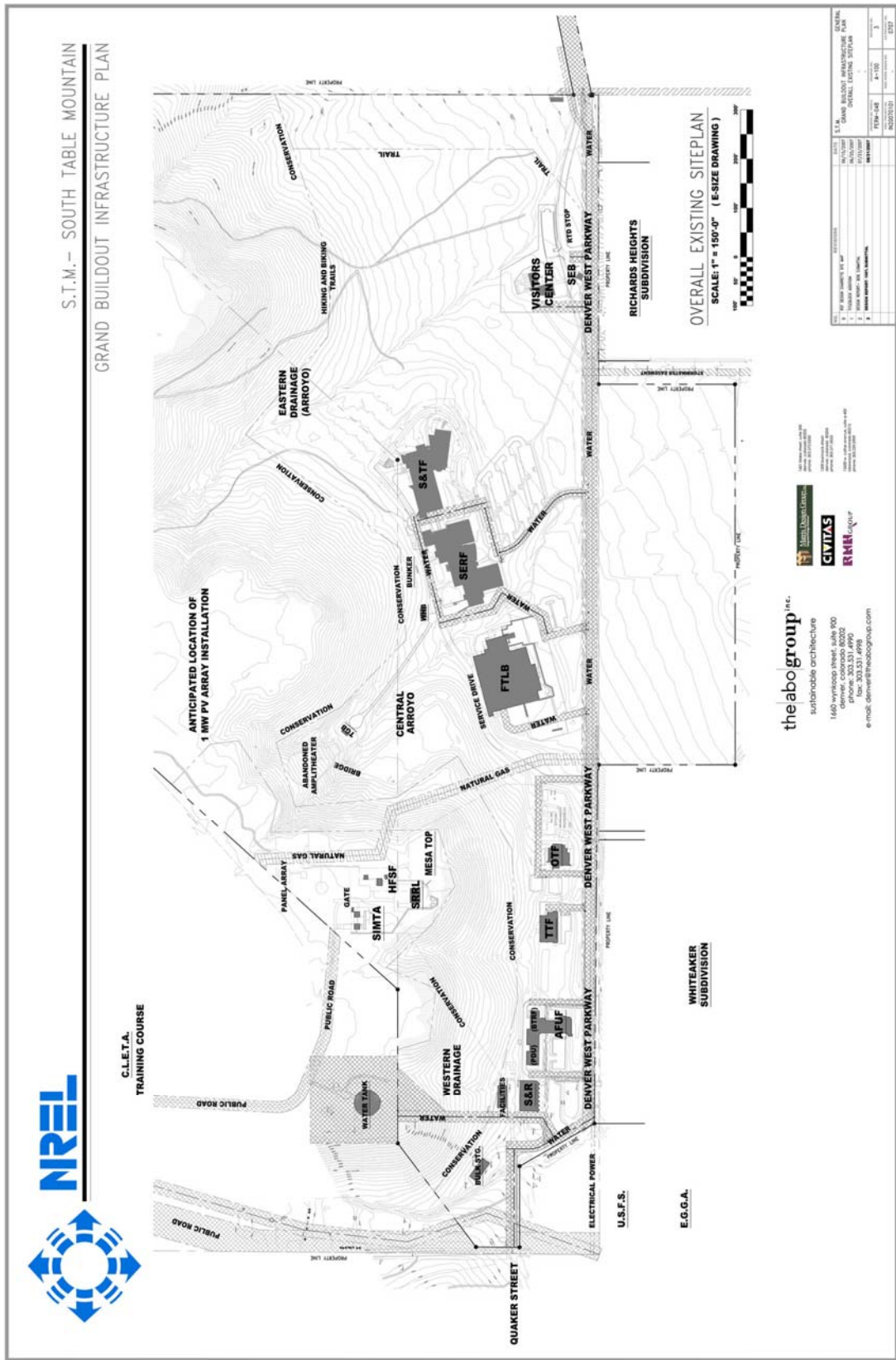

Figure 2-1. Current Site Layout

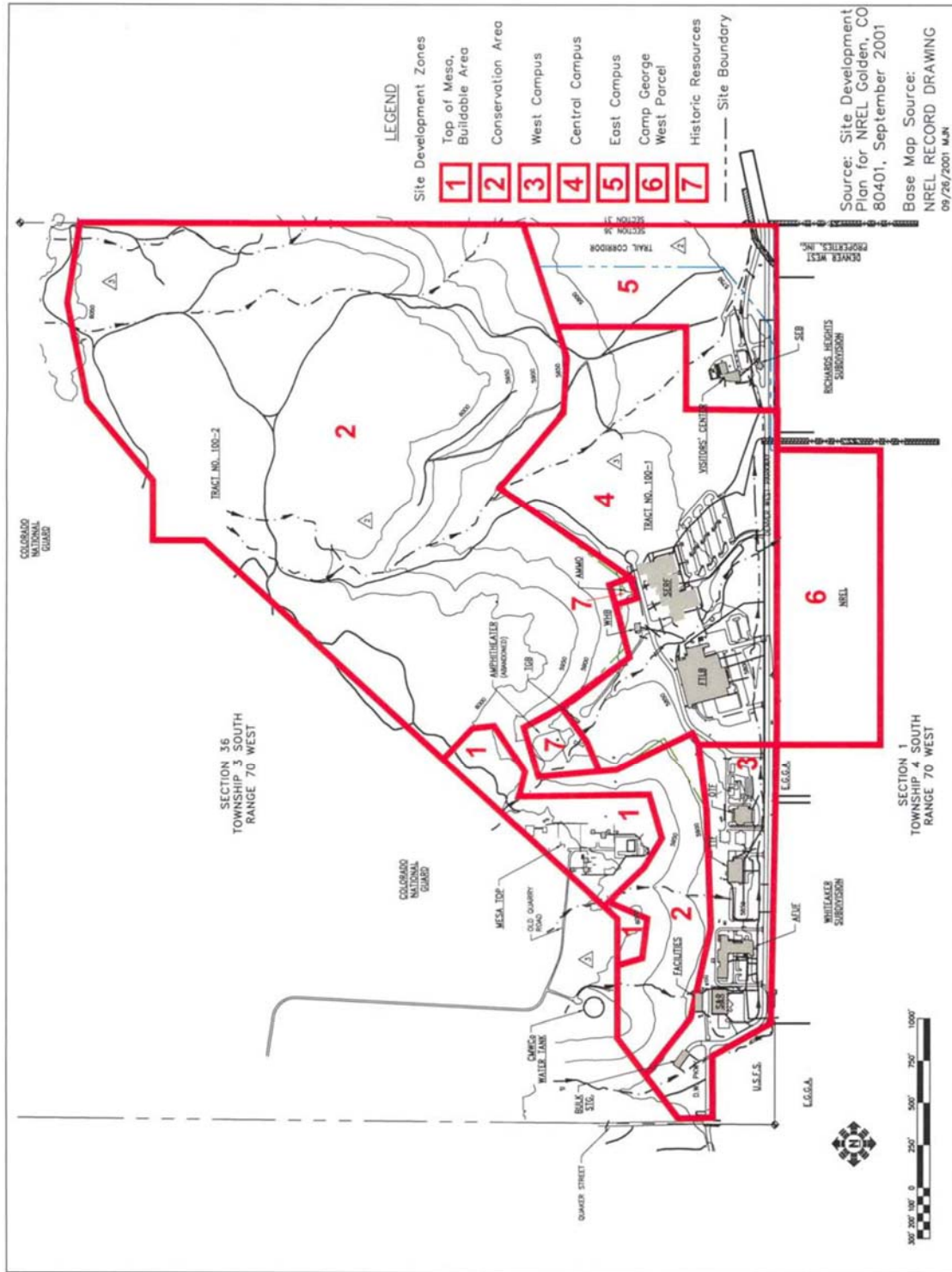

Figure 2-2. Site Development Zones

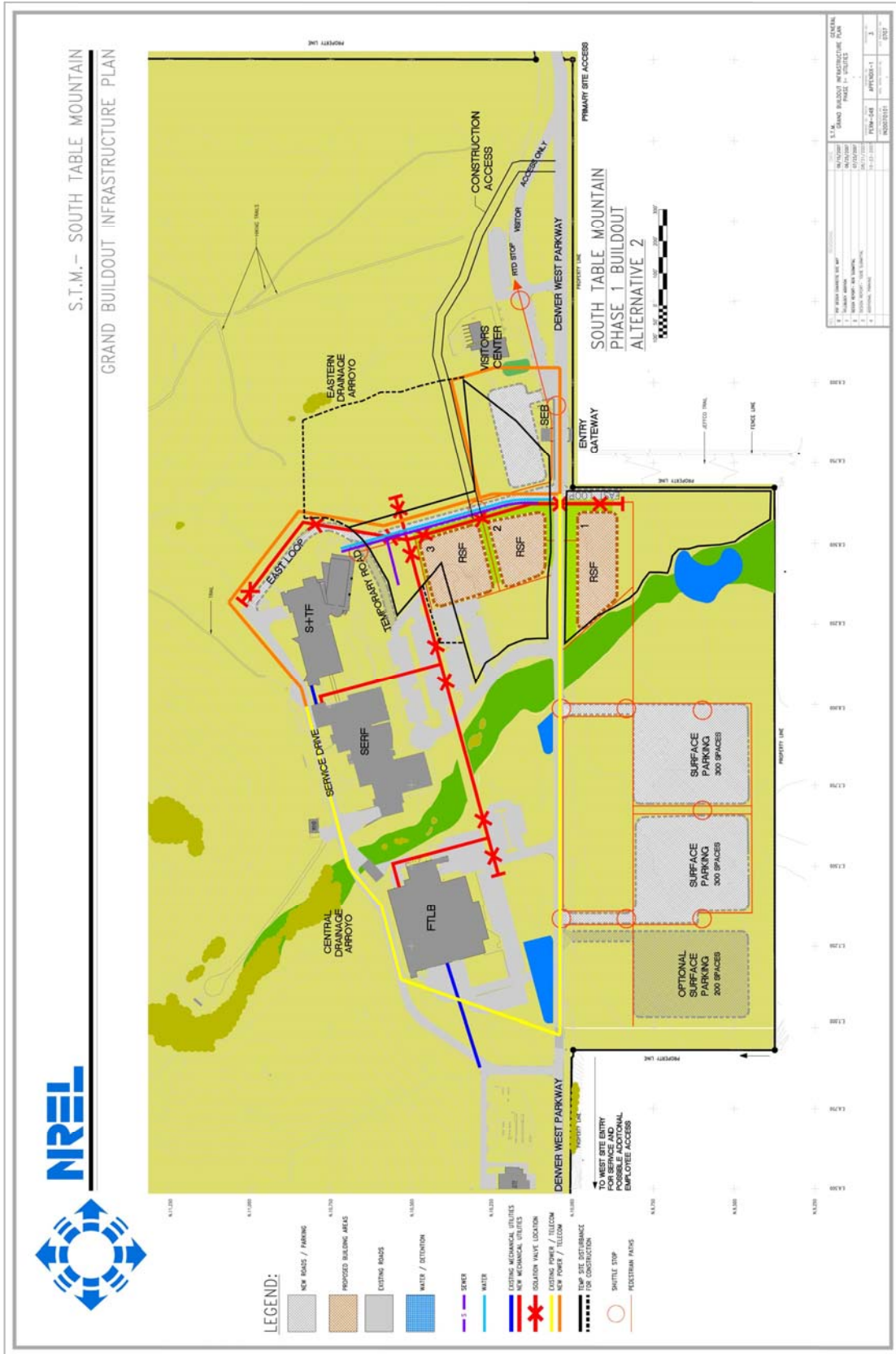

Figure 2-3. On-site Locations of Proposed Buildings and Upgrades

The proposed RSF would feature and demonstrate a cost-effective and energy-efficient office building design and may incorporate renewable energy generated onsite. It would include state-of-the-art demonstrations of the most recent building technology advances that would meet the U.S. Green Buildings Council Leadership in Energy and Environmental Design (LEED) Platinum rating.

The LEED Green Building Rating System is a program under the US Green Building Council that establishes standards in design, construction, and operation of high-performance green buildings and sites. There are five key areas in the rating system of achieving a sustainable project: sustainable site development, water savings, energy efficiency, materials selection, and indoor environmental quality.

RSF Traffic

Projected daily and peak rush hour vehicle-trip rates for the proposal to build the RSF and relocate approximately 800 employees from DWOP to the STM site were estimated using existing 24-hour traffic data that was counted at the STM entry points (FHU 2007). It should be noted that the STM site is a gated facility, which limits traffic to STM employees and other authorized personnel, vendors, and delivery and service/maintenance vehicles. The STM site also includes a Visitors Center that is open to the public. Traffic analyses must consider not only the direct trips made by employees to and from the site, but also the indirect traffic from such other activities as deliveries and visitors. These additional trips become a multiplying factor applied to the estimated number of employees to predict total vehicle trips. Overall, the estimated trip rates account for all site-related trips (employees, deliveries, visitors, etc.). The estimated vehicle-trip rates for NREL and the STM site are as follows:

Daily Trip Rate:	3.87 vehicle-trips per employee
AM Peak Rush Hour Trip Rate:	0.39 vehicle-trips per employee with an 83% inbound and 17% outbound split.
PM Peak Rush Hour Trip Rate:	0.36 vehicle-trips per employee with a 17% inbound and 83% outbound split.

Table 2-1 shows (1) the total daily and peak rush hour vehicle trips that occurred at the STM site in 2007; (2) trips that are anticipated to result in 2010 if the RSF were constructed and occupied (including projections for normal STM staff growth); and (3) a projection of the vehicle trips that might result in 2019 if the envisioned future buildout of the STM site were to occur. The 2019 conditions are presented for cumulative traffic impact analysis purposes in Section 4.0; however, this final SEA does not analyze other development proposals for full site buildout, because such actions are not sufficiently advanced in their conceptual design or funding authorizations.

Table 2-1. STM Vehicle Trip Generation

Analysis Year	STM Workers	Total Daily Trips	AM Peak Rush Hour Total Trips 7:30 – 8:30			PM Peak Rush Hour Total Trips 4:30 – 5:30		
			In	Out	Total	In	Out	Total
			2007	500	1,934	161	33	194
2010	1,430	5,530	460	94	554	89	426	515
2019	2,675	10,350	861	177	1,038	166	797	963

AM = ante meridiem; PM = post meridiem

Source: FHU 2007

The trip generation estimates in Table 2-1 reflect the proposed buildout of the STM site and assume employment levels of 1,430 employees for 2010 and 2,675 employees upon projected buildout in 2019. Actual trips generated by the STM site would vary based on actual employee levels and actual traffic conditions in the future.

2.2 Site Infrastructure Improvements (Phase 1 Buildout)

The Proposed Action includes a number of site infrastructure improvements. Figure 2-3 illustrates the types and approximate locations of the following proposed improvements.

New On-site Roads

Approximately 425 meters (1,394 feet, or about one-quarter mile) of two-lane, 6-meter (20-foot) wide paved road would be constructed in two segments. The first segment, the proposed East Loop Road, would replace an existing dirt road and would be approximately 275 meters (902 feet) long. It would run generally north from Denver West Parkway, loop around the Science and Technology Facility (S&TF) and connect to an existing service road located behind the Solar Energy Research Facility (SERF) and the FTLB. If the RSF were built on Building Pad 1, a short extension would be built south of Denver West Parkway. The second segment, a temporary road approximately 150 meters (490 feet) long, would be constructed to connect the new East Loop Road and the existing SERF/S&TF parking lots. The total footprint of these proposed roads, including shoulders, would be less than 0.4 hectare (1 acre).

To support construction activities for the RSF, a construction access road may be established to limit the interference between NREL employees and visitors and the RSF construction traffic. This access road, if built, would be installed by the RSF contractor on a temporary basis for approximately 2 years and would be removed and reseeded upon completion of the major construction activities at NREL. The approximate location of the construction access road is shown on Figure 2-3. Its estimated width is 15 to 30 meters (50 to 100 feet), and its estimated length is 460 meters (1,500 feet). The road's final location would be determined by NREL and the contractor to minimize traffic and environmental impacts. The RSF construction access road would cross two or more dry stream channels and require culverts or other structures to permit the unimpeded flow of runoff during storm events. All such structures would be adequately sized to meet the needs of construction vehicles and accommodate site runoff.

New Parking Areas

Several new surface parking lots would be built. A 100-space lot would be built west of the Visitors Center. This lot could provide parking for site visitors and RSF staff. Two larger lots, providing approximately 600 spaces, would be constructed in the southern half of Development Zone 6. A fourth lot would be built if required to support overflow parking from the RSF. This optional parking lot would hold approximately 200 vehicles and would also be located in the southern half of Development Zone 6. Portions of the parking lots in Zone 6 are anticipated to be below grade. Although they would be installed as surface parking in Phase 1 of the infrastructure project, the north end of the parking lots could be below grade with an embankment at the far north edge. The south ends of the lots are expected to be at grade or perhaps may need additional fill. This design would allow NREL to add one or more additional parking decks and/or a building in the future, as funding and programmatic needs dictate. The total permanent footprint of the new parking areas, including access roads, would be about 3.2 to 4 hectares (8 to 10 acres). The specific number and configuration of parking lots would be determined during final design.

Shuttle Bus Service

Due to the long walking distances and grades from the proposed parking lots and the existing and proposed new buildings, a limited tramway/shuttle system would be implemented. The anticipated route would be a loop from the new Zone 6 parking lots, east on Denver West Parkway, north on East Loop, west across the temporary roadway to the existing S&TF/SERF parking lot, and south down the existing parking lot access road to Denver West Parkway. The details of this tramway/shuttle system (vehicle type, stop locations, system communication, and fuel type) would be defined fully during final design of the system. Small weather shelters would also be built at selected shuttle bus stops.

Water, Sewer, Power and Telecommunications Improvements

New underground water, sewer, power, and telecommunication lines would be installed to support the RSF and future site development (see Figure 2-3). Because most of the improvements would be underground, they would not result in significant permanent footprints. Although the precise locations and dimensions for equipment installation would be finalized during the final integrated design phase, DOE anticipates that the Proposed Action could entail the following types of equipment installation during the Phase 1 infrastructure upgrades:

- Install a new 30-centimeter (12-inch) diameter water line from the FTLB or the SERF and route it along the new East Loop Road to service the proposed RSF.
- Install a new 20-centimeter (8-inch) diameter sewer main under the new East Loop Road. This sewer line would service the S&TF, the RSF, and potential future site facilities. If one of the RSF buildings were situated south of Denver West Parkway, this sewer main would be extended to service it.
- Install new power and telecommunication lines that would tie into existing lines, most likely near the SERF. The new lines would run along the new East Loop Road and around the new parking lot west of the Visitors Center.
- Install new mechanical utility lines and isolation valves that would connect to the FTLB or SERF and be routed to the proposed RSF.
- Install a new 30-centimeter (12-inch) diameter water line that would connect to the existing off-site water main near Moss Street. It would be capped off pending future site development.
- Install new power lines above and below ground as necessary to service future site development projects.

HVAC System Improvements

Phased installation of HVAC distribution and generation infrastructure would coincide with the site development work to support the new buildings. The design of all HVAC systems would consider the full buildout to minimize rework on installed systems. As part of the Proposed Action, Phase 1 would provide sufficient HVAC infrastructure to support the RSF by 2009 and nearby buildings by 2012. Because most of these improvements would be underground, they would not result in significant footprints. The equipment and engineering specifications for the Phase 1 HVAC infrastructure upgrades that would be installed would be finalized during the integrated design phase. However, DOE anticipates that the Proposed Action could entail the following types of HVAC upgrades:

- Install 40-centimeter (16-inch) diameter heating water supply and return pipes, and 40-centimeter (16-inch) diameter chilled water supply and return pipes, to serve the proposed RSF. The pipes would follow the route of the future North Loop Road (tentatively planned for construction during future site buildout) and then south following the proposed East Loop Road, which would be constructed as part of the Proposed Action. (The conceptual North Loop Road is shown in Section 4.0, Figure 4-1.)
- Install 25-centimeter (10-inch) diameter heating water supply and return pipes, and 25-centimeter (10-inch) diameter chilled water supply and return pipes, from the FTLB south to the loop distribution piping.
- Install 20-centimeter (8-inch) diameter heating water supply and return pipes, and 20-centimeter (8-inch) diameter chilled water supply and return pipes, from the SERF, south to the loop distribution piping
- Install 25-centimeter (10-inch) diameter heating water supply and return piping, and 25-centimeter (10-inch) diameter chilled water supply and return piping, along the route of the proposed East Loop Road to support future buildings on the east side of the road.
- Install system isolation valves at appropriate locations for easy maintenance and future building connections.
- Install additional heating and chilled water pumps and associated equipment in the FTLB and SERF to feed the loop distribution system.
- Keep the existing heating and chilled water spine serving the west campus from the FTLB in service, independent of the central campus distribution loop.

Drainage and Stormwater Improvements

A new water detention basin (or a system of basins) and associated outfalls would be constructed at strategic locations within the central drainage dry stream channel to reduce and control off-site run off. Flow from new construction (the RSF, parking lots) would be directed toward the basins. One basin would probably be constructed near the southeast corner of Zone 6. Other basins could be constructed in the dry stream channel north of Denver West Parkway. The final size, number, and location of the proposed basins would be determined after the configuration of the proposed RSF was finalized.

Landscaping, Walkways, and Bike Paths

Open space landscaping, pedestrian walkways, gathering spaces, bike paths, and other campus amenities would be constructed. The location and design of these features would be determined based on the final location of the proposed RSF building or buildings.

2.3 Thermochemical User Facility

The Proposed Action includes upgrades to the existing TCUF and the TCUF high-bay housed in the FTLB (see Figure 2-3), and the addition of the TBPP, a thermochemical biorefinery pilot plant to be constructed either in or adjacent to the FTLB. The TBPP would be connected to the TCUF and integrated into the overall TCUF operations.

Current TCUF Operations

The TCUF is a multifunctional thermochemical biomass conversion facility. Thermochemical processing means that the biomass is processed by the application of heat and/or non-biochemical chemical reactions. The TCUF is DOE's only state-of-the-art pilot plant dedicated to thermochemical biomass conversion. The TCUF can operate in two modes: pyrolysis or gasification.

Gasification with resulting catalytic conversion of carbon monoxide (CO) and hydrogen (H₂) to ethanol is currently the major focus of the thermochemical

research program at NREL, with the goal of demonstrating an integrated process of biomass to ethanol by 2012. NREL is currently researching an integrated gasification process that involves indirect heating (no oxygen in the gasification reactor) followed by tar reforming and catalytic conversion of clean syngas to alcohols.

Biomass refers to living and recently harvested biological material that can be used as fuel or for industrial production. Most commonly, biomass refers to plant matter grown for use as biofuel, but it also includes plant or animal matter used for production of fibers, chemicals, or heat. Biomass may also include biodegradable wastes that can be burned as fuel. It excludes organic material which has been transformed by geological processes into substances such as coal or petroleum.

In the pyrolysis mode, the system uses heat to convert biomass into liquid products. In the gasification mode, primarily gaseous products are formed. Pyrolysis is accomplished by transferring energy from a heat source into the biomass at a relatively high rate in the absence of free oxygen. Typical pyrolysis temperatures in the reactor are between 450 °C and 700 °C. Gasification is achieved at higher temperatures of up to 900 °C. Air or oxygen is often used to improve yields and system efficiency.

The system can process 0.5 tonnes (0.55 tons) of biomass a day. Major equipment includes a fluid bed reactor, a thermal cracker, a catalytic tar reformer, a mechanical solids feeder, cyclones, filtering equipment such as bag houses and ceramic and coalescing filters, a condensation train/wet scrubber, blower, and a thermal oxidizer (Figure 2-4).

Depending on the mode of operation, the TCUF operations can generate either pyrolysis oils or syngas (mainly CO and H₂ with lesser amounts of carbon dioxide and methane). The process of pyrolysis involves heating the material from ambient temperatures to temperatures between 500 °C and 700 °C in the absence of air. This process liberates the volatile matter in biomass in the form of a liquid product that can be further processed into fuels and chemicals. Under most normal conditions, pyrolysis oil, sometimes called biocrude, is the primary product generated by pyrolysis. The oils consist of a wide range of chemical compounds with molecular weights between 16 and approximately 300. Typical pyrolysis yields based on a unit weight of biomass feed are as follows: oils – 45 to 65 percent; char – 10 to 20 percent; permanent gases – 20 to 30 percent; water – 10 to 25 percent.

In the gasification mode as practiced in the TCUF, the temperatures are higher than in pyrolysis and steam is added to promote chemical reactions. The higher temperatures are used to “crack” the pyrolysis molecules to H₂, CO, carbon dioxide (CO₂), and methane while steam-carbon reactions promote the formation of additional CO and H₂. Yields from gasification of biomass vary widely depending on feedstock, but generally give condensibles (oil and water) of around 1 percent, char from 10 to 20 percent, and permanent gases from 80 to 90 percent.

Current TCUF Environmental Hazards

This subsection describes the potential environmental hazards associated with current TCUF operations. The proposed TCUF upgrades and TBPP would not result in a qualitative change to these environmental hazards, but would increase quantities of hazardous materials and hazardous waste generated. The

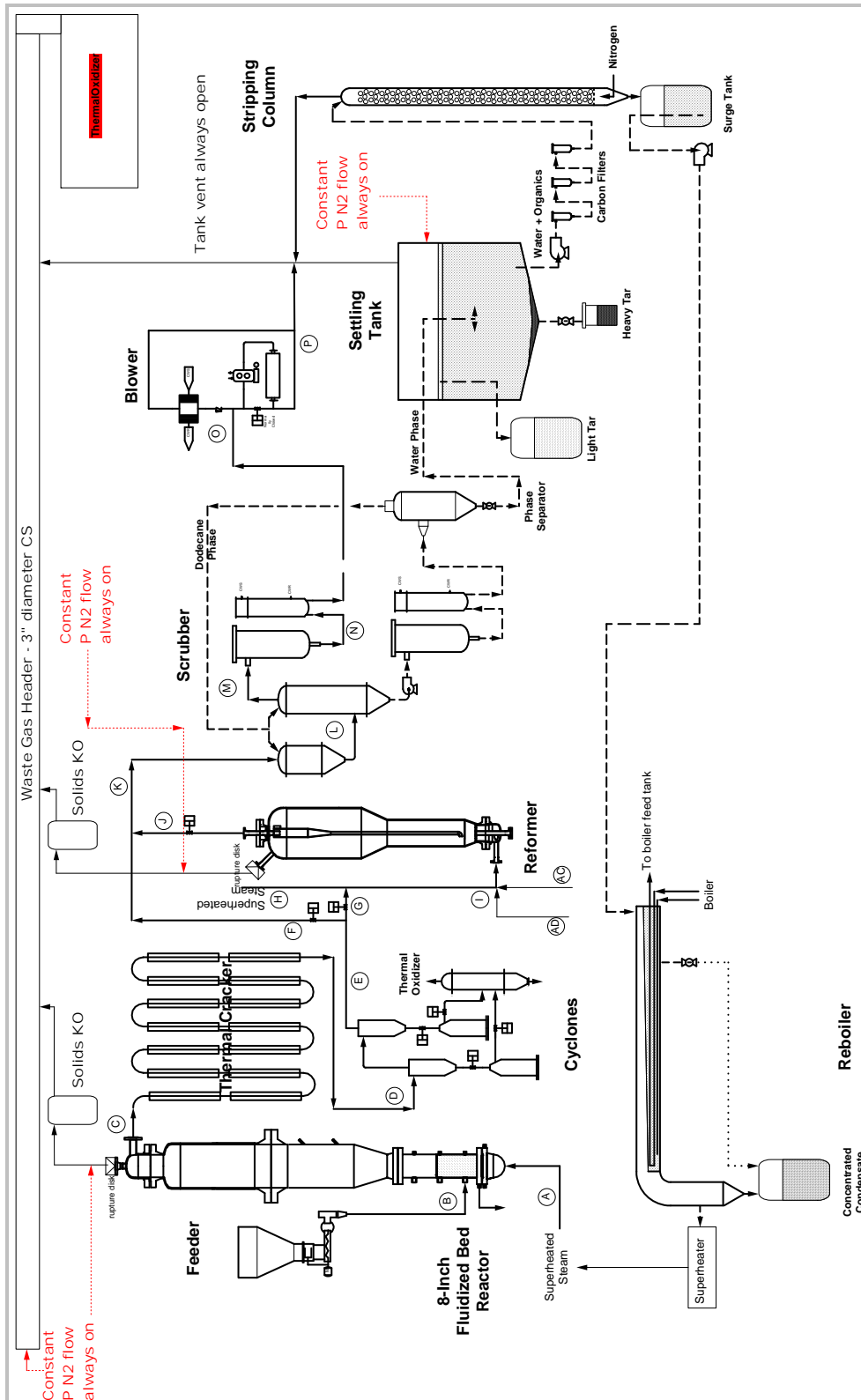

Figure 2-4. TCUF Equipment and Operations

methods used to minimize the hazard or quantity of hazardous materials generated by TCUF operations, and the controls used to prevent the potential hazard from adversely affecting the environment, are documented in the TCUF Safe Operating Procedures (SOP) document: *Safe Operating Procedures for the Thermochemical Process Development Unit at FTLB High Bay (FTLB/131-02)* (NREL 2007b).

The TCUF operates under Colorado Air Pollution Control Division operating permit 99JE0400. This permit allows up to 45 tonnes (50 tons) per year (cumulative) of the following feedstock materials: municipal solid waste, refuse-derived fuel, wood, plant material, agricultural residues, black liquor, and recycled tires and plastics. The air permit and records related to operation under the permit are maintained and kept in the TCUF control room.

Maximum gas emissions from the TCUF occur during gasification operations that use air or oxygen to help gasify the feed. Assuming a nominal feed rate of 15 kilograms (kg) (33 pounds [lbs]) per hour biomass, a 2:1 steam-to-feed ratio, a 20:1 feed-to-oxygen ratio (by weight), and 5 wt% char produced, the gaseous emission is approximately 72 kg (159 lbs) per hour of carbon dioxide and water vapor.

Liquid products are typically used for other research and therefore are not waste streams. The steam condensate during gasification is recycled within the process to minimize liquid wastes. Disposal of any liquid waste is addressed in the SOP.

Because of the sensitive nature of highly flammable solvent use and its disposal, non-flammable solvents are used during operational cleanup for the TCUF. These can include diethylene glycol monoethyl ether (DGME) and sodium hydroxide (NaOH). However, there is occasional need for incidental cleaning using more hazardous solvents such as acetone and methanol. Use of these solvents is limited to a hood or other approved local exhaust ventilation units.

During a typical run day (assuming 10 hours of biomass input), on average the TCUF generates approximately:

- 220 kg (484 lbs) of hazardous waste in the form of condensed liquid products,
- 22 kg (48 lbs) of non-hazardous waste in the form of char,
- 1 kg (2.2 lbs) of hazardous waste in the form of spent solvents,
- 10 kg (22 lbs) of hazardous waste in the form of cleanup wipes, rags, etc.

Pyrolysis oils are a complex chemical mixture containing over 100 compounds with varying degrees of composition that are process- and feedstock-dependent. Although there are a number of studies on the acute and chronic health hazards of these oils, the hazards of the oil as a whole are not fully known.

OSHA HAZCOM Standard 29 CFR 1910.1200 states that the whole must be treated as the sum of its individual components. Therefore, because of the presence of formaldehyde, formic acid, acrolein, etc, pyrolysis oils, and any airborne contaminants released from these oils, must be treated as extremely hazardous and carcinogenic. There are also health hazards associated with the oils because other components are toxic, corrosive, a reproductive toxin, and a sensitizer. The oils may also affect target organs such as the liver and kidney. Consequently, the TCUF is a “Designated Work Area” and is posted accordingly. Specific engineering controls, administrative controls, and required personal protective equipment are listed in the SOP and are adhered to.

Proposed TCUF Upgrades and TBPP Addition

The proposed upgrade and additions to the capabilities of the TCUF are anticipated to be completed in two phases. The components of each phase may vary, depending on funding availability, but anticipated activities associated with each phase are as follows. During Phase 1, approximately 75 to 140 square meters (800 to 1,500 square feet) of specially designed, high-pressure flammable-liquid-rated, high bay space would be constructed either in or adjacent to the FTLB as the TBPP. This new space would house pilot-scale equipment to demonstrate fully integrated biomass gasification, syngas cleanup, and ethanol synthesis. Several unit operations, including gas compression, acid gas removal, fuel synthesis, and fuel distillation, would be designed and procured during this phase (Figure 2-5). The new TBPP operations would be structurally isolated from the FTLB for fire safety reasons and would incorporate building overpressure protection. Controls would be incorporated to restrict personnel access.

Phase 2 would involve removal of surplus equipment, and laboratory space within the FTLB high bay would be removed or modified to accommodate the construction of approximately 53 square meters (575 square feet) of low bay laboratory space for mini-pilot scale experiments. Approximately 26 square meters (275 square feet) of existing control room space would be remodeled or reconfigured to support the additional laboratories. These additional control rooms would be located within the high bay space of the TCUF. Design and construction of up to four mini-pilot scale thermochemical conversion systems would also be completed during this phase of the project. These systems would occupy the low bay laboratories described above.

The processes that would be pilot-tested using the upgraded TCUF and the TBPP are described in detail and illustrated with flow charts in the technical report *Thermochemical Ethanol via Indirect Gasification and Mixed Alcohol Synthesis of Lignocellulosic Biomass*, NREL/TP-510-41168, April 2007 (NREL 2007c): <http://www.nrel.gov/docs/fy07osti/41168.pdf>, which is incorporated into this final SEA by reference. This report evaluates the design and techno-economic characteristics of a full-scale biomass-to-ethanol thermochemical conversion plant. DOE estimates that the input/output volumes for feedstock, process water, and products for the proposed TCUF upgrades and the TBPP would be approximately *one four-thousandth* of those described in NREL report for a full-scale plant.

The proposed upgraded TCUF and the TBPP would not use significantly more biomass feedstock or different types of feedstock compared to current TCUF operations. Under its current air operating permit, the TCUF is authorized to process up to 45 tonnes (50 tons) of biomass annually; however, it has never processed more than 6.4 tonnes (7 tons) annually. Additionally, the facility would produce 11,340 kg (25,000 lbs) of mixed alcohols (approximately 13,627 liters [3,600 gallons] > 90 percent alcohol). These alcohols could include methanol, ethanol, propanol, butanol, and pentanol. NREL would attempt to find end users for this material and/or recycle some of the alcohols back into the process. However in the absence of identifying an end user or recycling, this material would be considered hazardous waste and disposed accordingly.

A full-scale plant would require approximately 2 liters (0.5 gallon) of process water for every 1 liter (0.25 gallon) of ethanol produced and would consume approximately 54,000 kg (119,050 lbs) of process water per hour, or approximately 54,000 liters (14,265 gallons) per hour (NREL 2007b). Applying the one four-thousandths scale factor describe above, the process water demand of the proposed TCUF upgrade would be approximately 13.5 liters (3.6 gallons) per hour.

The TBPP elements of the upgrade would be built in the FTLB or in a loading dock area adjacent to the existing TCUF highbay. The loading docks are currently utilized for storage because the shipping and receiving functions were relocated to another dedicated facility. However, loading dock capabilities

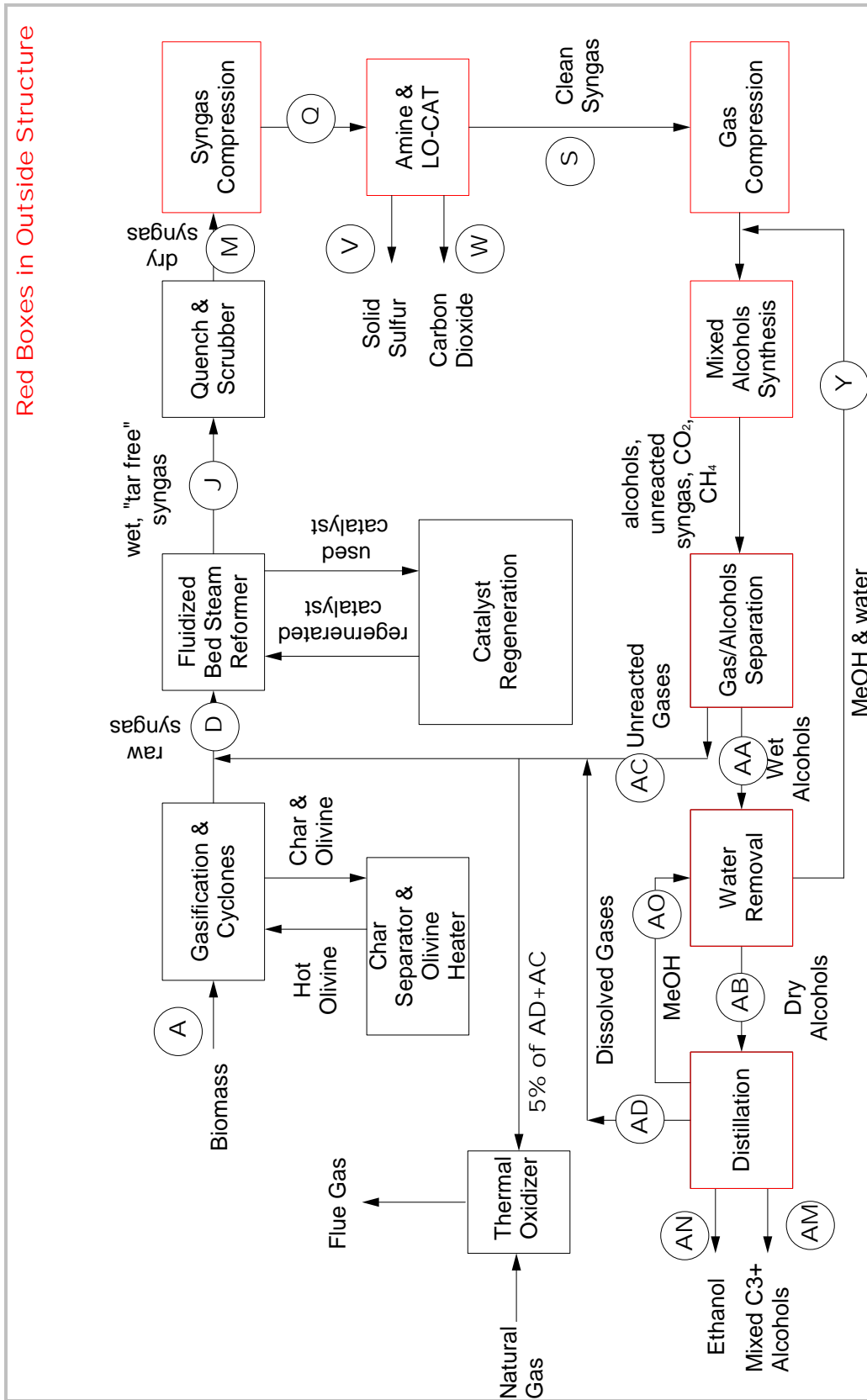

Figure 2-5. Integrated TCUF/TBPP Unit Operations

would be incorporated into the existing building modifications to allow direct truck unloading when necessary, either by providing ramp access or by modifying an existing building wing that is at the appropriate dock height.

To address specific components of DOE's expanded biomass research and development agenda, the following major infrastructure elements and fuel synthesis unit operations would be installed or implemented to upgrade the TCUF and integrate the TCUF for alcohol synthesis during Phase 1 of the project:

- high-pressure bay,
- slip-stream regenerator for tar reformer ,
- acid gas removal system,
- dry gas compression, including surge capacity,
- catalytic reactor for alcohol synthesis, and
- distillation and storage for methanol recycle.

Equipment and facilities for Phase 2 would include laboratory space for research on gasification, gas cleaning, and alcohol synthesis which are the three major technical barriers to commercialization of lignocellulosic ethanol. Table 2-2 lists and describes the major systems that would be installed during the two phases of the proposed TCUF/TBPP upgrade.

2.4 No Action Alternative

The No Action Alternative would leave the site in its current configuration. Neither the RSF nor any new infrastructure would be constructed, and the current levels of research and operations at the TCUF would be maintained without any upgrades. However, the No Action Alternative would not preclude other projects addressed or contemplated in the site-wide EA from being proposed at such time as NREL determined them to be ready for evaluation under NEPA.

2.5 Alternatives Considered But Not Analyzed

The Proposed Action and the No Action Alternative are the only alternatives specifically addressed in this final SEA. The Proposed Action alternative is to implement the three-development project described in Sections 2.1 through 2.3. However, alternatives to the Proposed Action were raised and considered prior to the scoping period for the site-wide EA. The site-wide EA resulted in a finding that development in the central and south central portions of the site, rather than other locations, was the most appropriate, technically feasible, and environmentally benign alternative. Other alternatives considered were eliminated from further analysis. The rationales for eliminating these alternatives remain applicable to the current Proposed Action and are summarized below:

- New Site and Off-Site Improvements Alternative: not considered feasible because of the technical and cost implications associated with decentralized operations and site/infrastructure complications.
- Other Site Development Configuration Alternatives: not considered feasible because of the interrelated nature of the proposed facilities, site development constraints, and the inherent flexibility of the Proposed Action with respect to future facility footprints.
- Reduced Development Intensity Alternative: not considered feasible because it is inconsistent with the Proposed Action's purpose and need and the intent of preparing the site-wide EA, which is to facilitate NREL in carrying out its mission.

Table 2-2. TCUF Upgrades and TBPP Elements

Phase 1: TCUF Upgrades and TBPP	
Item	Description
Catalyst Regeneration System; TCUF	Slipstream catalyst regeneration system to validate tar reforming catalyst regeneration protocols prior to implementation at full scale.
Acid Gas Removal; TBPP	Full-stream wet scrubber for removal of H ₂ S and CO ₂ prior to alcohol synthesis reactor
Gas Compression; TBPP	Full-stream gas compressor to bring clean syngas up to alcohol synthesis pressure (c.a. 1,000 psi)
Alcohol Synthesis Reactor; TBPP	Full-stream slurry bed reactor for catalytic synthesis of ethanol and other higher alcohols
Distillation Column; TBPP	Full-stream distillation column for separation of ethanol from by-products
Phase 2: Modifications and Additions to High Bay	
Laboratory Space for Bench-Scale and Lab-Scale Reaction Systems	Renovation of high-bay areas adjacent to TCUF; installation of 3 to 4 new laboratories for hazardous research; class 1 explosion-proof rating with pressure relief
Gasification Research and Process Development Laboratory	Specially-designed lab with mini-reactors and bench-scale systems to carry out research on biomass gasification
Gas Cleaning Research and Process Development Laboratory	Specially-designed lab with mini-reactors and bench-scale systems to carry out research on syngas cleaning
Catalytic Synthesis Research and Process Development Laboratory	Specially-designed lab with mini-reactors and bench-scale systems to carry out research on syngas conversion to alcohols and other fuel/chemical products
Exploratory Research on Thermochemical Conversion of Biomass	Specially-designed lab with mini-reactors and bench-scale systems to carry out exploratory research and process development on biomass conversion to fuels and chemicals

3.0 EXISTING ENVIRONMENT AND ENVIRONMENTAL IMPACTS

General Site Description

The 132-hectare (327-acre) STM site is located on the southeast side of STM, north of Interstate 70 (I-70) and west of the I-70 and Denver West Boulevard interchange in unincorporated Jefferson County near Golden, Colorado. The DWOP is located in the city of Lakewood. The areas surrounding the STM and DWOP sites are within portions of unincorporated Jefferson County, as well as the cities of Golden and Lakewood in Jefferson County. The Pleasant View Metropolitan District, within unincorporated Jefferson County, overlies portions of each of these jurisdictions. These jurisdictions are described and illustrated in detail in the site-wide EA (DOE 2003).

Of the 132 hectares (327 acres) at the STM site, 55 hectares (136 acres) are available for development. A total of 72 hectares (177 acres) is protected by a conservation easement, and development on 5.7 hectares (14 acres) is restricted by utility easements. There are currently seven laboratory facilities, a few small test facilities, and several support buildings on the site. The site includes acreage on the STM mesa top, slope, and toe; and approximately 10 hectares (25 acres) that were formerly part of the Colorado National Guard facility, established between 1903 and 1924, at Camp George West. Figures 2-1 and 2-3 show the STM site and the locations of the three proposed improvement projects that are the subject of this final SEA. For those characteristics of the existing environment that essentially remain unchanged since the 2003 site-wide EA and the July 2007 EA were issued, this final SEA reiterates or summarizes the descriptions found in those earlier EAs. Otherwise, this final SEA describes relevant environmental changes since the 2003 site-wide EA and 2007 EA were issued.

The impacts expected from the Proposed Action are generally bounded by the impacts reported in the site-wide EA. However, in cases where impacts from the Proposed Action may not be adequately bounded by or fully discussed in the site-wide EA (for example, traffic impacts from the proposed RSF), more detailed discussions are provided.

3.1 Environmental Impacts of the Proposed Action

3.1.1 Land Use and Planning

3.1.1.1 Existing Environment

The descriptions of land use and planning found in the site-wide EA remain current and are summarized below.

Current land use at the site includes research and development facilities, office space, support buildings, and testing areas. The STM complex (including the DWOP space that is currently leased to DOE) provides approximately 56,900 square meters (612,000 square feet) of facilities and workspace for approximately 1,230 staff, including federal employees, contractors, and temporary personnel.

The proposed RSF would be located in the southeast quadrant of Zone 4 and/or the northeast quadrant of Zone 6 south of Denver West Parkway. The 22-hectare (55-acre) Zone 4 includes major DOE facilities such as SERF, FTLB, and the S&TF. It also includes wet laboratories and space for research such as experiments with H₂, toxic gases, photovoltaics (PV), biofuels, and industrial technology. This zone is considered the center of the STM complex.

The 10-hectare (25-acre) Zone 6 (Camp George West Parcel) is an undeveloped area of the site immediately south of Denver West Parkway. Zone 6 is designated for general research and development with minimal use of hazardous materials, and for research support facilities. It is bordered on the east and west by residential areas and on the south by a partially completed regional park. The Jefferson County Open Spaces Program conceptual plan for the South Table Mountain area includes a walking trail segment from a parking area near the new baseball field in the regional park, north along Kendrick Street, east along Denver West Parkway, then across Denver West Parkway to an access point to the conservation easement area on the mesa top.

The proposed site infrastructure improvements (Phase 1 buildout), which would support the proposed RSF and future site developments, would occur almost entirely in Zones 4 and 6. The proposed 100-space parking lot for the RSF and for visitors (which would be built north of Denver West Boulevard and directly west of the existing Visitors Center) and buried power and telecom lines around the new lot may extend slightly into the extreme southwest portion of Zone 5. The 10-hectare (25-acre) Zone 5 includes the Visitors Center and East Entrance; otherwise, this zone is undeveloped. The zone is designated to be for general research and development with dry laboratories and minimal use of hazardous materials. It is also an area where research support facilities could be located.

The proposed TCUF upgrades and the TBPP would occur within and adjacent to the existing FTLB in Zone 4.

3.1.1.2 Impacts of the Proposed Action

The land use and planning impacts of the three proposed site development projects are bounded by the discussion of impacts presented in the site-wide EA (DOE 2003); these impacts are summarized below.

Research Support Facilities

Land use for the proposed RSF would be consistent with the designated uses of NREL Planning Zone 4 or 6. The final RSF buildout could convert up to 2.4 hectares (6 acres) of undeveloped STM site land to site facility use. If Building Pads 2 or 3, which are north of Denver West Parkway, were used, the new land use would be consistent with the current and planned use of site land for STM site facilities in Planning Zone 4. If Building Pad 1 were used, land immediately west of and directly across the street from a residential neighborhood, the Richard Heights Subdivision, would be converted from undeveloped land to office space. Although development in Zone 6 would be consistent with the planned use for this zone, development on Building Pad 1 would increase the intensity of office uses adjacent to a residential area. Using this land for the RSF would be consistent with much of the surrounding land use and the overall mix of residential and office-related land uses in the area. If construction occurred on Building Pad 1, a new RSF office building would be located immediately adjacent to a portion of a Jefferson County Open Spaces Program walking trail, which provides a short corridor for the public to walk from a parking area to a main access point that leads to existing and conceptual trails on the conservation easement area on the mesa top.

Site Infrastructure Improvements

The proposed site infrastructure improvements would convert approximately 3.5 to 4.5 hectares (9 to 11 acres) of undeveloped site land into new parking lots, paved roads, and infrastructure. Additionally, if constructed the construction access road to the RSF would temporarily disturb up to 1.2 hectares (3 acres) for up to 2 years. The three proposed parking lots in Zone 6 would convert about one-third of the zone into parking area and access roads. The area immediately south of Zone 6 is currently under development

as a regional park. It is not anticipated that development of parking spaces within Zone 6 would affect any contemplated recreational use at the planned park to the south, particularly considering that use of the park would likely be most intense during the evening and on weekends when the STM site would be least active, and the proposed parking areas would therefore be largely empty.

TCUF Upgrades and TBPP

The proposed upgrades to the TCUF and addition of the TBPP would occur within and adjacent to the existing FTLB and would be fully consistent with and have no impact on the current land uses within Development Zone 4.

3.1.2 Traffic

3.1.2.1 Existing Environment

Transportation Facilities and Circulation

This section describes existing transportation facilities and identifies existing traffic volumes and service level operating conditions of streets and freeways in the vicinity of the STM site. Traffic analyses in this final SEA are based on a recent technical report (FHU 2007) prepared for DOE and NREL. That report evaluated projected employee increases and quantified the effect of the traffic resulting from the Proposed Action on the local and regional transportation systems. Key elements of the report are summarized in this final SEA.

Currently, approximately 500 NREL workers are housed at the STM site and another 730 DOE and NREL workers are in leased office space south of I-70 and the STM site in the DWOP (Figure 3-1). Most of the workers access the two locations via the I-70 and Denver West Marriot Boulevard exit. STM site workers then travel northwest to Denver West Parkway, turning west to enter the STM site. DWOP workers turn south to Cole Boulevard, then east into several buildings in the DWOP.

Existing Roadways and Traffic Volumes

Existing vehicular traffic counts were obtained in October 2007 at several key intersections in the site vicinity. These intersections were chosen to determine potential effects of the project. Traffic was counted during the peak morning (AM) and evening (PM) traffic periods of a weekday at the intersections listed on Table 3-1. Table 3-1 also lists the numerical identifiers used as abbreviations for these intersections in the traffic study report and on subsequent figures and tables in this final EA.

In addition, daily (24-hour) traffic volumes were counted along several key roadways in the site vicinity, including:

- Denver West Parkway west of Denver West Drive,
- Denver West Parkway west of Denver West Marriott Boulevard,
- Denver West Marriott Boulevard north of I-70,
- Denver West Marriott Boulevard north of Colfax Avenue,
- Colfax Avenue west of Denver West Marriott Boulevard,
- Indiana Street north of Colfax Avenue,
- South Golden Road east of Quaker Street,
- Quaker Street north of South Golden Road.

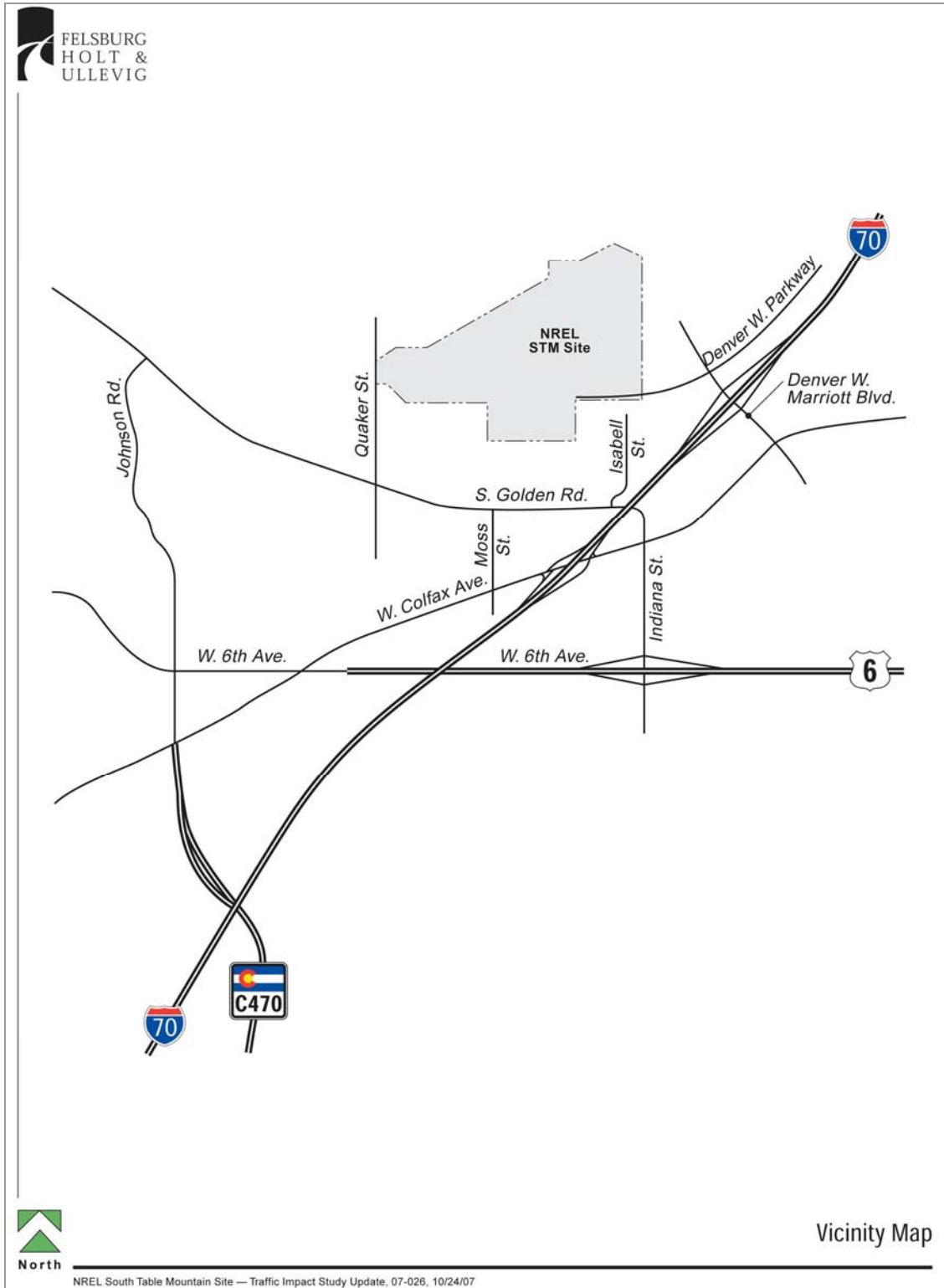

Source: FHU 2007

Figure 3-1. STM Site Vicinity Map

Table 3-1. Traffic Surveyed Intersections around the STM Site

Analyzed Intersections	Intersection Numerical Code Used on Figures and Tables
Denver West Parkway and Denver West Drive	1
Denver West Parkway and Denver West Marriott Boulevard	2
Denver West Marriott Boulevard and the I-70 Westbound Ramps	3
Denver West Marriott Boulevard and the I-70 Eastbound Ramps	4
Denver West Marriott Boulevard and Cole Boulevard	5
Denver West Marriott Boulevard and Colfax Avenue	6
Colfax Avenue and Moss Street	7
Colfax Avenue and the I-70 Westbound Ramps	8
Colfax Avenue and the I-70 Eastbound Ramps	9
Colfax Avenue and Indiana Street	10
South Golden Road and Quaker Street	11
South Golden Road and Moss Street	12
South Golden Road and Isabell Street	13

Source: FHU 2007

Figure 3-2 summarizes the daily and peak rush hour traffic counts, by lane and by direction of travel, for the 13 intersections listed in Table 3-1.

Existing Operating Conditions

The existing peak rush hour traffic volumes identified on Figure 3-2 were analyzed to determine existing operational conditions. Traffic operational conditions are described with a level of service (LOS), a qualitative measure of traffic flow based on the average delay per vehicle at a controlled intersection. LOS are described with a letter designation of A, B, C, D, E or F. An LOS “A” represents conditions with minimal delay, while a LOS “F” represents conditions with much longer delays. Typically, a LOS of “D” or better is considered to be acceptable operational conditions (FHU 2007).

Analysis of the capacity of intersections controlled by signal lights produces an overall LOS representative of all movements through the intersection. Analysis of the capacity of intersections without signal lights, or stop sign-controlled intersections, produces LOS results for each movement that must yield to conflicting traffic at the intersection. Table 3-2 summarizes LOS criteria for both signalized and unsignalized (stop sign-controlled) intersections.

The results of the analyses in terms of calendar year (CY) 2007 LOS for the intersections identified in Table 3-1 are provided on Figure 3-3. Existing intersection traffic controls and lane geometry are also identified on Figure 3-3. The results of the analyses indicate that all of the study intersections currently operate at acceptable LOS ranging from LOS A to LOS D during the peak rush hours, except for left-turn movements onto South Golden Road from both Moss Street (intersection 12) and Isabell Street (intersection 13) FHU 2007).

Future Baseline Traffic Volumes and Operating Conditions

This section describes the forecast future baseline traffic conditions under the No Action Alternative for the study area in the year 2010. CY 2010 is assumed for the buildout of the actions proposed in this final SEA.

Final Supplement-1 to Final Site-Wide Environmental Assessment:
National Renewable Energy Laboratory South Table Mountain Site

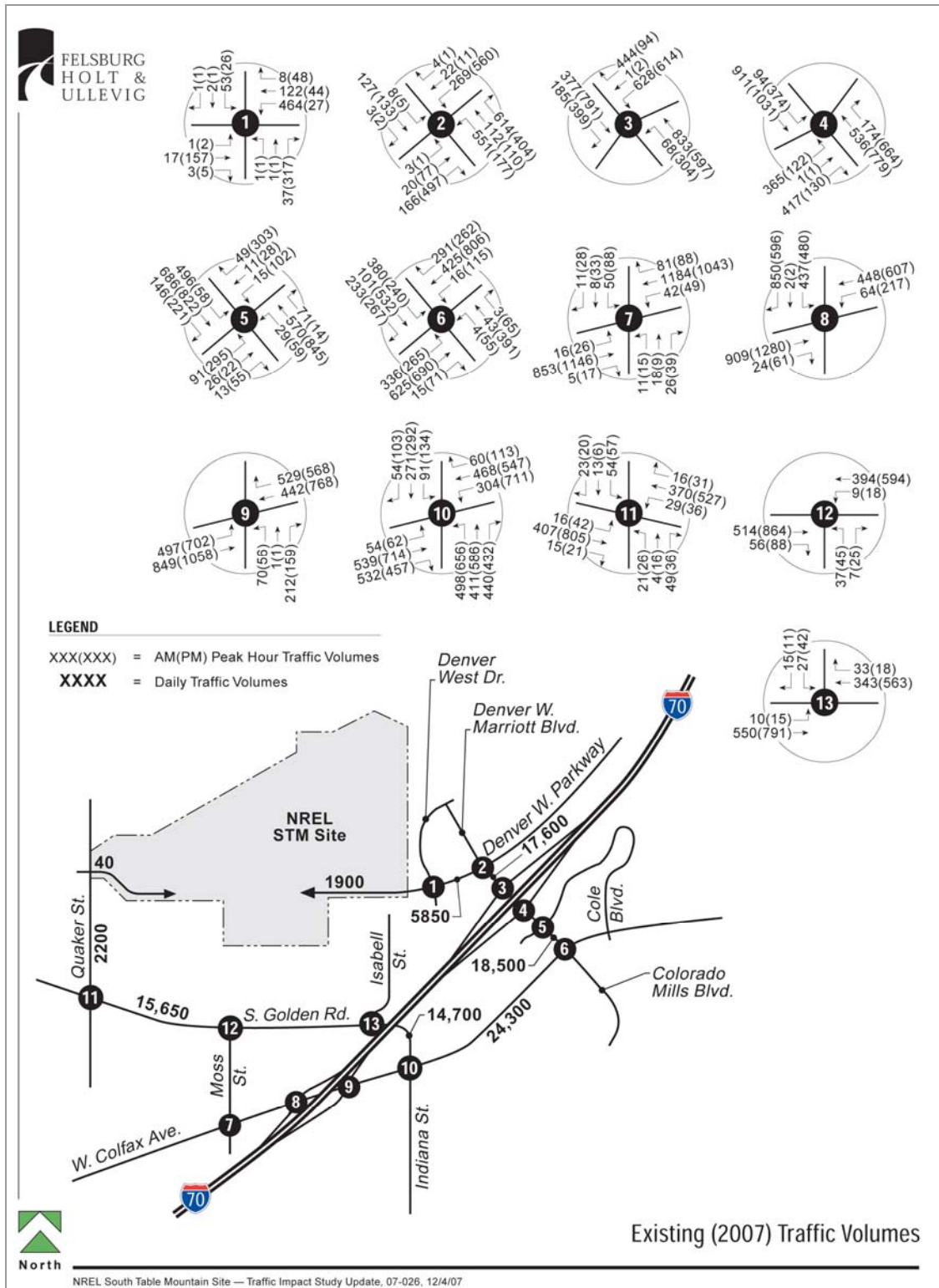

Figure 3-2. Existing (2007) Traffic Volumes

Table 3-2. LOS Criteria

Level of Service	Average Control Delay per Vehicle (sec/vehicle)	
	Signal Light-Controlled Intersections	Stop Sign-Controlled Intersections
A	≤ 10	≤ 10
B	> 10 to 20	> 10 to 15
C	> 20 to 35	> 15 to 25
D	> 35 to 55	> 25 to 35
E	> 55 to 80	> 35 to 50
F	> 80	> 50

Source: FHU 2007

Because the Proposed Action would take some years to design, construct, and occupy, the baseline traffic data must be projected into the future to compare conditions under both the Proposed Action and the No Action Alternative. Recent traffic studies (FHU 2007) conclude that traffic volumes in the study area have increased, on average, since 2002 by about 3 to 4 percent annually. Traffic generated by the Colorado Mills shopping area is responsible for most of this traffic growth. In general, traffic growth in the study area is expected to taper off in the future because the area is becoming more fully developed. Future traffic projections applied in this study were based on the *Metro Vision 2030 Plan* prepared by the Denver Regional Council of Governments (DRCOG 2005). Future traffic forecasts were developed from the DRCOG regional travel demand model and from traffic forecasts documented in the *Interstate 70/32nd Avenue Interchange Environmental Assessment* prepared for the Colorado Department of Transportation (CDOT), Federal Highway Administration, and City of Wheat Ridge (FHU 2006). From these resources, it was determined that traffic in the study area is expected to increase by about 1 percent annually, not including traffic growth associated with the STM expansion (FHU 2007).

Figure 3-4 shows projected year 2010 background traffic volumes, which would include existing 2007 STM traffic. The volumes shown on this figure represent a base case—i.e., conditions under the No Action Alternative. Figure 3-5 shows the projected LOS at these intersections under the No Action Alternative. These volumes and the associated traffic operations are provided as a baseline to allow a comparison of the impacts associated with the Proposed Action. As shown on Figure 3-5, projections of future traffic under the No Action Alternative suggest that without some form of intersection improvements, at least four intersections—8, 9, 12, and 13—could experience unacceptable LOS of E or F due to normal expansion of traffic in the area.

3.1.2.2 Impacts of the Proposed Action

As shown in Table 2-1, under the Proposed Action employment levels at the STM site would increase from the 2007 level of approximately 500 workers to 1,430 workers in 2010 due to the relocation of approximately 800 existing employees from the DWOP to the STM site and some new hires. This increased STM employment would result in an increase in daily trips from the current levels of 1,934 trips to a projected 5,530 trips in 2010 under the Proposed Action. The effect of this increase in traffic is shown through projected vehicle counts (Figure 3-6) and through projected changes in LOS (Figure 3-7). LOS levels of E and F generally represent unacceptable delays to motorists and are trigger points for transportation agencies to take steps to improve intersections or find other means to reduce traffic delays, if possible.

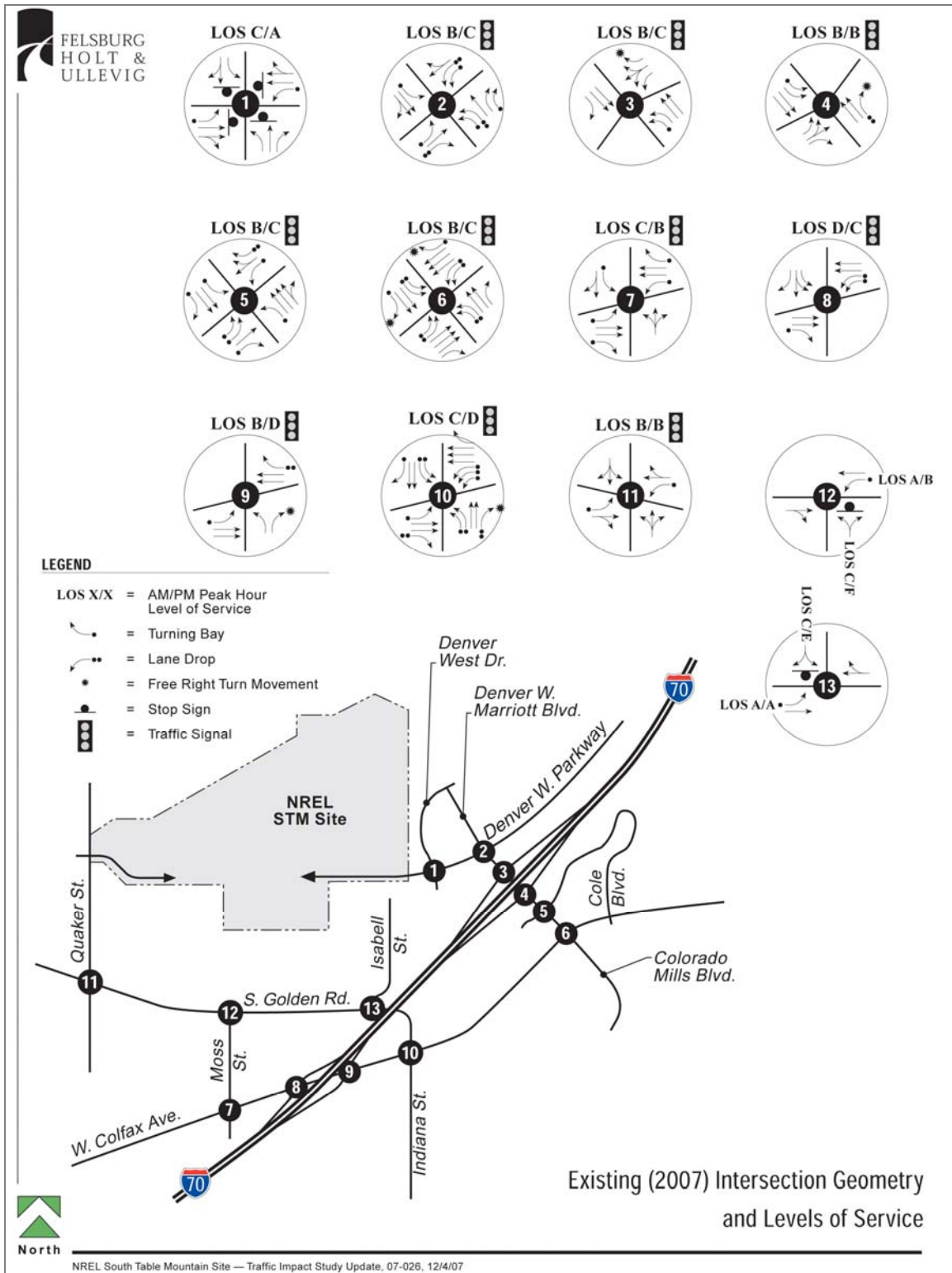

Source: FHU 2007

Figure 3-3. Existing (2007) Intersection Geometry and LOS

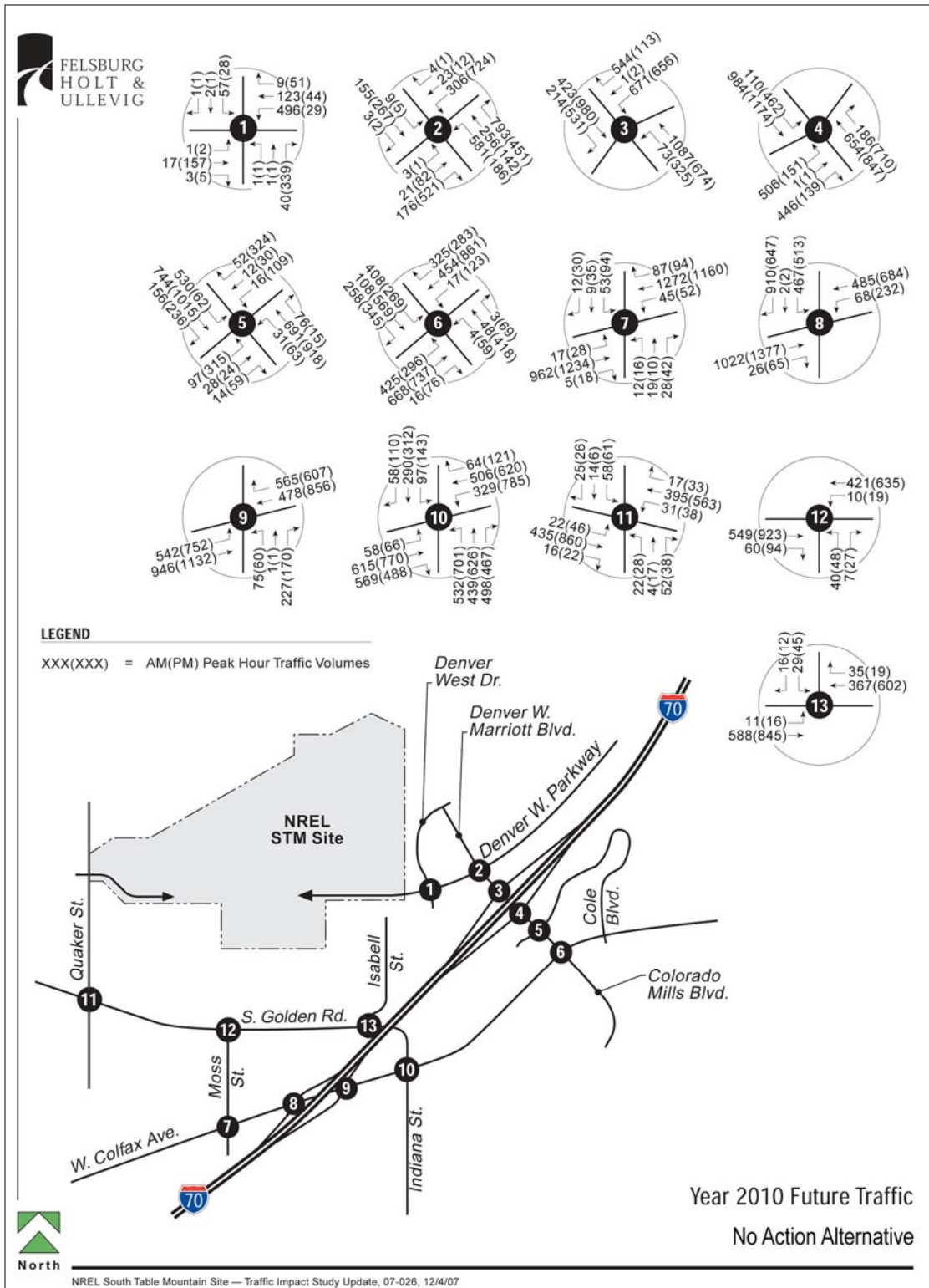
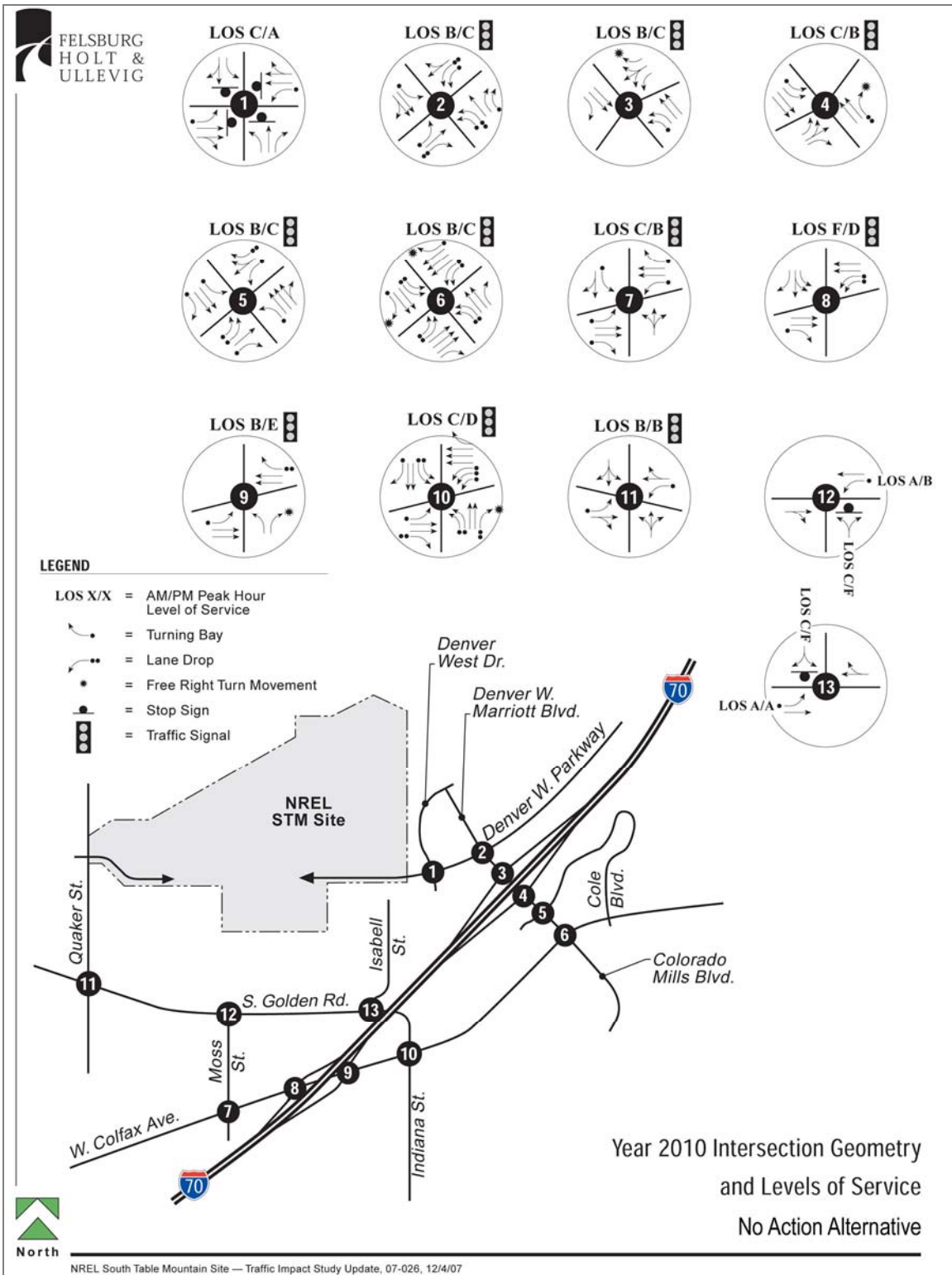
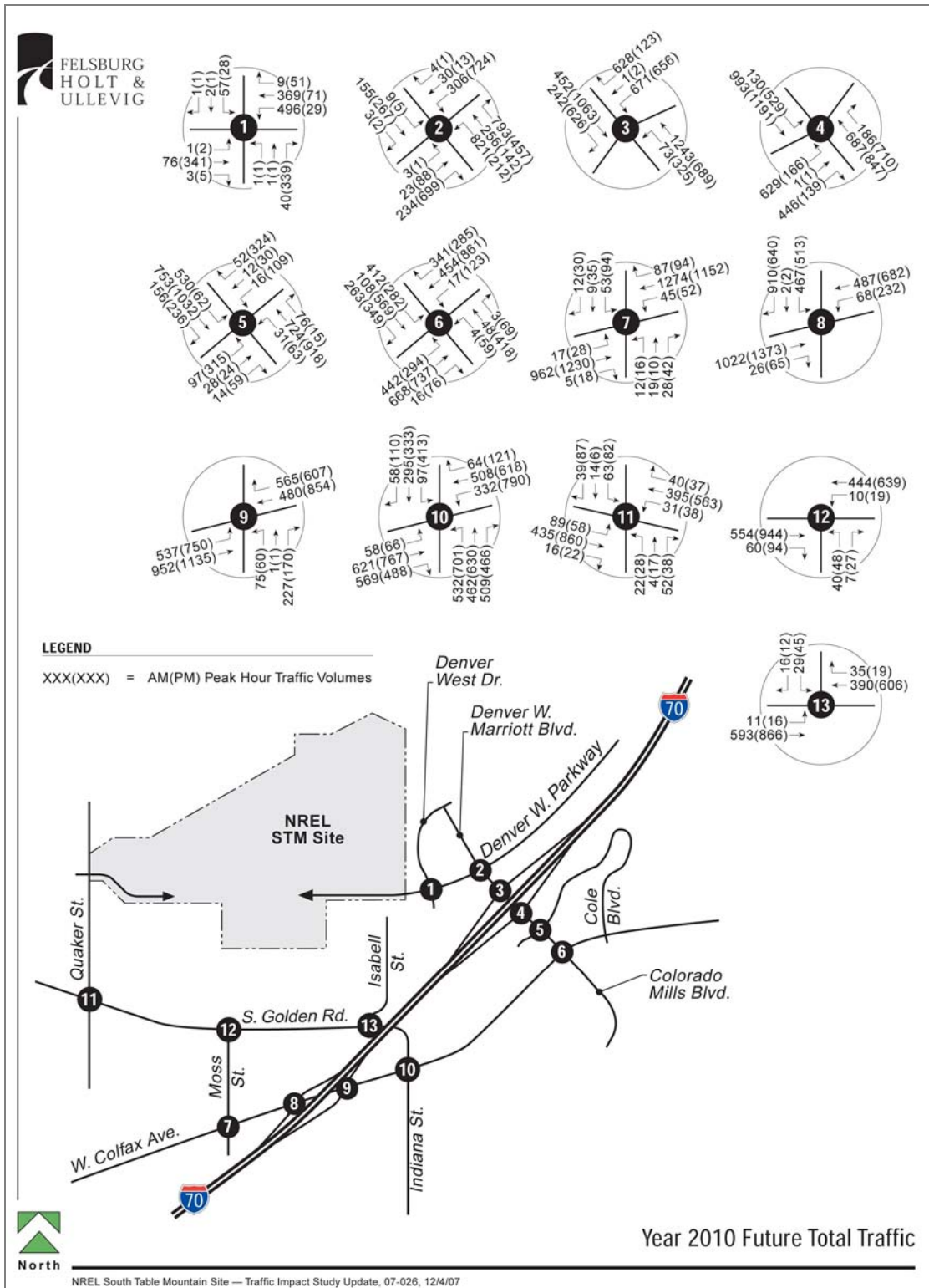

Figure 3-4. Year 2010 Traffic - No Action Alternative



Source: FHU 2007

Figure 3-5. Year 2010 Intersection Geometry and LOS - No Action Alternative



Source: FHU 2007

Figure 3-6. Year 2010 Traffic - Proposed Action

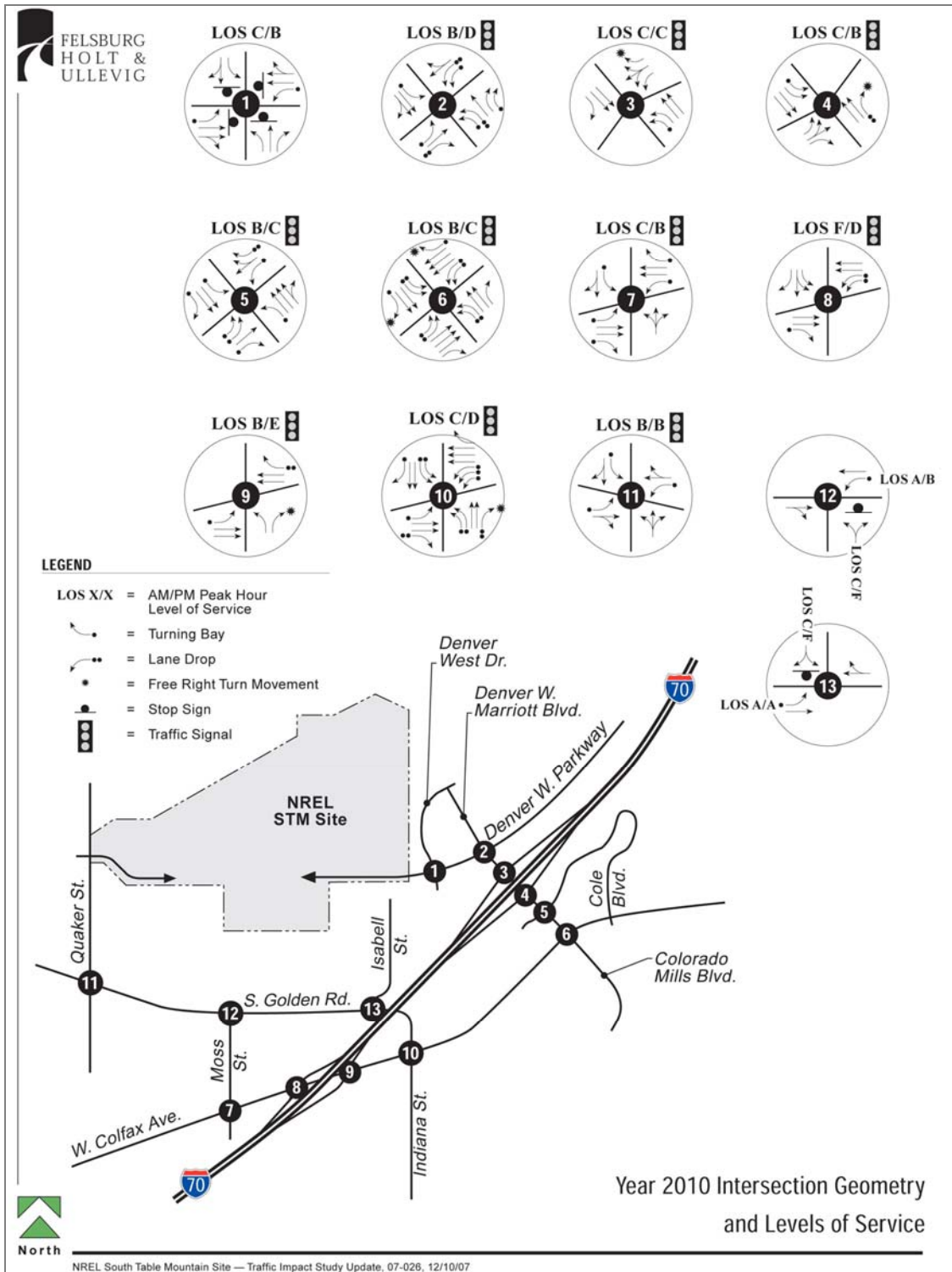

Source: FHU 2007

Figure 3-7. Year 2010 Intersection Geometry and LOS - Proposed Action

Under the Proposed Action, DOE and NREL would increase their use of the Quaker Street access to the STM site. This increase would not change the LOS of the Quaker Street/South Golden Road intersection; in 2010, it would be an LOS B under either the No Action Alternative (Figure 3-5) or the Proposed Action (Figure 3-7). Comparing Figures 3-4 and 3-6 shows that there would, however, be an increase in the peak rush hour traffic experienced in the neighborhood. Specifically, during the peak AM rush hour, Quaker Street between the STM entrance/exit and South Golden Road would average approximately 1.9 vehicles every minute under the No Action Alternative (without the proposed expansion of the STM site), and under the Proposed Action it would carry approximately 2.6 vehicles every minute. During the PM peak rush hour, this section would average approximately 2.1 vehicles every minute under the No Action Alternative; under the Proposed Action, it would carry approximately 3.5 vehicles every minute.

A comparison of Figure 3-4 to 3-6 and Figure 3-5 to 3-7 suggests that implementation of the Proposed Action may result in changes at intersections 2 and 3 that would be directly attributable to the Proposed Action, not the result of general increases in traffic attributable to normal projected growth in the area. However, although DOE's and NREL's increased traffic may become the tipping point for the degradation of operations at these intersections, Table 3-3 shows that under the Proposed Action, in CY 2010, DOE's and NREL's contribution to the overall traffic volume at intersections 2 and 3 would be only 15 percent and 11 percent, respectively, during the PM peak. Although the LOS at intersection 2—Denver West Parkway and Denver West Marriott Boulevard—assuming a second right-turn lane were added, and averaging all traffic from all directions, is projected to be an LOS D during PM peak rush hour (see Figure 3-7), the flows from the STM approach are projected to be far worse and, as a result, some operational problems would be experienced. Specifically, during the PM peak, there would be a substantial increase in delay (by a factor of about 2 or more) if no major access improvements were provided. For intersection 2 without improvements, these delays would be near or above the LOS E threshold, which is an unacceptable operating condition (FHU 2007). Traffic lines or queues from the STM site would be 224 meters (735 feet) or more (about 37 cars), possibly beyond the Denver West Drive intersection, resulting in LOS F conditions where extreme delays would be experienced, taking multiple cycles of the signal to get through the intersection. For these reasons, this intersection has been analyzed further.

Table 3-3. Proportion of Site-Generated Traffic for Year 2010 Conditions

Intersection	No Action Proportion		Proportion of Site Traffic Under Proposed Action	
	AM	PM	AM	PM
1. Denver West Parkway at Denver West Drive	18%	30%	41%	47%
2. Denver West Marriott Boulevard at Denver West Parkway	6%	8%	16%	15%
3. Denver West Marriott Boulevard at I-70 Westbound Ramp	4%	6%	13%	11%
4. Denver West Marriott Boulevard at I-70 Eastbound Ramp	3%	3%	9%	6%
5. Denver West Marriott Boulevard at Cole Boulevard	2%	2%	3%	2%
6. Colfax Avenue at Denver West Marriott Blvd.	1%	1%	3%	2%
7. Colfax Avenue at Moss Street	1%	1%	1%	1%
8. Colfax Avenue at I-70 Westbound Ramp	1%	1%	1%	1%
9. Colfax Avenue at I-70 Eastbound Ramp	1%	1%	1%	1%
10. Colfax Avenue at Indiana Street	1%	1%	2%	1%
11. South Golden Road at Quaker Street	<1%	<1%	9%	6%

Traffic problems would primarily be experienced along the eastbound approach to intersection 2 (the Denver West Parkway/Denver West Marriott Boulevard intersection) during the PM peak rush hour—that is, when employees would be leaving the STM site. Multiple traffic analyses were conducted for this intersection to determine critical expansion level thresholds associated with alternative access scenarios and other key mitigation measures (FHU 2007). Specifically, this “sensitivity evaluation” of intersection 2 was conducted to determine the impact that increased employment levels would have on peak rush hour traffic operations and delays. The resulting intersection and critical approach delays obtained from the evaluation established critical employee thresholds. The current roadway system is expected to have adequate capacity to accommodate about 1,075 employees without any intersection improvements, which equates to a total of about 387 vehicle-trips during any peak rush hour (FHU 2007). Because this threshold would be insufficient to meet the projected employment levels of 1,430 under the Proposed Action, NREL funded studies to explore a range of impact mitigation measures that would either accommodate the increased traffic or effectively reduce the number of trips occurring during peak rush hours.

Mitigation Measures

Historically, DOE and NREL have encouraged, and in some cases funded, employee utilization of regional and local transportation alternatives, including the following:

- Regional Transportation District (RTD) local, limited, express, and regional bus service;
- NREL-funded shuttle service between DWOP, selected RTD bus stops, and the STM site;
- NREL-funded EcoPass (RTD’s unlimited transit pass purchased by NREL for its employees);
- Denver Regional Council of Governments (DRCOG) RideArrangers carpool and vanpool services;
- RTD and CDOT Park-n-Rides.

Through ongoing studies with traffic consultants (FHU 2007 and UrbanTrans 2008), DOE/NREL has evaluated both physical improvements to the Denver West Parkway/Denver West Marriott Boulevard intersection and Traffic Demand Management (TDM) programs.

The specific physical remedy recommended for this intersection is to construct dual right-turn lanes along the eastbound approach to the Denver West/Denver West Marriott Boulevard intersection. Operationally, this action would accommodate a total of about 1,450 employees, which equates to about 522 vehicle-trips during any peak rush hour (FHU 2007).

In its TDM studies (UrbanTrans 2008), DOE/NREL evaluated the following range of mitigation options:

- Alternative workweek strategies
 - Flexitime—An alternative work schedule technique that gives employees the option of setting their workday start and stop times. The intent is to allow employees more flexibility to adjust their work hours to individual needs and to avoid congested travel periods. Most policies specify a core period in the middle of the workday, such as 10 a.m. to 3 p.m., when all employees are required to be present.
 - Telecommuting—A work arrangement program whereby employees work at a location other than the conventional office or central headquarters, usually from home or an office close to

home. Telecommuting can remove commute trips from the roadway system or reduce the length of commute trips.

- Expanded DOE-operated shuttle service to existing regional RTD hubs.
- Expanded use of carpools and vanpools.
- Enhanced physical facilities and amenities, such as sidewalks directly connecting shuttle dropoff locations and building entrances, bike racks, bike lockers, and on-site locker rooms and showers for use by employees.

Varying the extent of the measures taken under each element of its TDM program, the traffic mitigation studies summarized the program recommendations into groups labeled Low, Medium, and High, reflecting the increasing level of investment required for increasing amounts of trip reductions during the problematic PM peak rush hour. Based on extensive employee surveys and case study evaluations of actual TDM programs that are employed at sites similar to the STM site, Table 3-4 was generated to reflect the relative reduction in trip numbers that could be anticipated by implementing the TDM program. For more details of the elements of the TDM grouping, the reader is referred to the *Traffic Mitigation Plan* (UrbanTrans 2008).

Table 3-4. Trip Reduction Associated with Each Recommendation Group

Transportation Strategy	Expected Trip Reduction		
	Low	Medium	High
Flextime	8.0%	11.0%	12.0%
Telecommute	0.0%	1.9%	2.5%
Shuttle Transit	4.5%	6.0%	6.5%
Carpool	0.3%	2.3%	2.0%
Vanpool	0.0%	2.5%	5.0%
Bike/Walk	0.5%	1.0%	1.5%
Total Impact	13.3%	24.7%	29.5%

Source: UrbanTrans 2008

Based on the projected traffic volumes provided by the traffic study (FHU 2008) and the results of the mitigation studies (UrbanTrans 2008), DOE and NREL understand that several mitigation measures could be taken to prevent or minimize unacceptable degradation of traffic flow at the Denver West Parkway/ Denver West Marriott Boulevard intersection due to the Proposed Action. Therefore, DOE and NREL are committed to implementing both near-term and longer-term traffic mitigation measures as a part of its Proposed Action. In the near term, defined as no later than the opening of the RSF, DOE and NREL would implement the following measures to the extent necessary to minimize traffic impacts:

- A combination of several TDM measures at the “medium” level, at a minimum,
- Expanded use of the Quaker Street entrance,
- A review of off-site parking options from which workers could be bused to the STM site.

Based on the analyses in the traffic and mitigation studies, these measures would prevent the degradation of traffic flow to unacceptable LOS and still accommodate the projected 1,430 employees that would occupy the STM site in 2010. Further, these measures could accommodate more than 1,800 employees (UrbanTrans 2008; FHU 2007).

To accommodate the planned buildout of the STM site beyond 1,800 employees, DOE and NREL are committed to pursuing the following longer-term traffic mitigation actions:

- Seek funding/approvals for intersection upgrades—Denver West Parkway/Denver West Marriott Boulevard,
- Pursue a third STM entrance from South Golden Road.

Based on the analyses in this final SEA, DOE will be actively discussing the implementation of roadway improvements at the Denver West Parkway/Denver West Marriott Boulevard intersection with the City of Lakewood, Jefferson County, the Marriott Corporation, and CDOT. Before finalizing this final SEA and either issuing a Finding of No Significant Impact or preparing an EIS for the Proposed Action, DOE will develop a mitigation action plan, as required under DOE's NEPA implementing regulations, that will specify the traffic monitoring program that would be implemented and the sequence of mitigation measures that would be applied to prevent an unacceptable degradation of traffic flow through this intersection.

3.1.3 Safety and Accidents

Safety and accident concerns surrounding the Proposed Action relate primarily to operation of the TCUF and TBPP. The standard hazards include typical industrial hazards associated with operation of the existing facility and proposed upgrades. The non-standard hazards include operations at high temperatures and pressures, use of combustible materials, and generation of hazardous products such as pyrolysis oil and syngas.

NREL views good industrial safety practices and adherence to the guidelines for handling these materials as essential for worker safety. Pyrolysis oil is a mixture of more than 100 chemical compounds. Many of these compounds are carcinogenic and pose a risk from inhalation, ingestion, and dermal contact. Gasification end products (syngas) include H₂, CO, methane, and CO₂. H₂ gas has a wide flammability and explosive range, CO is both flammable and toxic, methane is flammable, and CO₂ is an asphyxiant. These hazards are well-documented, and NREL uses well-understood procedures to protect workers from these hazards. The existing TCUF has been operated for several years, and safe operating procedures have been developed and implemented by NREL.

A review of the operational hazards, safety features, and safe operating practices that control the hazards was undertaken to postulate possible accident scenarios that might result during operation of the current facility, as well as additional accidents that could occur as a result of the proposed TCUF upgrades and new TBPP elements. A detailed discussion of these analyses can be found in Appendix B. Table 3-5 identifies the accident scenarios and the likelihood of their occurrence; and describes the predicted impact to the off-site public, the involved worker (individual working in the TCUF), and the uninvolved workers that work elsewhere on the STM site. For the purposes of analysis in this final SEA, very conservative assumptions regarding quantities of material involved, duration of the accidents, and atmospheric dispersion conditions have been used. Under actual accident conditions, the resulting consequences would probably be much less severe than those presented in Appendix B.

Accidents involving fires or explosions could have direct effects on both workers and the public. For those accidents involving the release of hazardous materials, dispersion modeling has quantified the public and worker exposures that would result from these accidents, and those concentrations are compared to Emergency Response Planning Guidelines (ERPGs). ERPGs were developed as planning guidelines to anticipate human adverse health effects caused by exposure to toxic chemicals. ERPGs are

Table 3-5. TCUF/TBPP Accident Consequence Summary

Accident Scenario	Likelihood of Occurrence^a	Impact to the Off-site Public	Impact to Involved Worker	Impact to Uninvolved Worker
Current TCUF Configuration (No Action)				
Spill or rupture of a 114-liter (30-gallon) drum of pyrolysis oil, resulting in atmospheric release	Full spill: Remote	ERPG-2 limits not exceeded for any single chemical, nor would the cumulative effect of all chemicals exceed ERPG-2 limit.	For unprotected workers, health effects would be anticipated. However, workers are trained in emergency response, and personal protective equipment is available to reduce the potential of permanent health effects.	ERPG-2 limits are exceeded for formic acid and acetaldehyde, but effective emergency response would limit exposure time to less than an hour. No permanent health effects would be anticipated.
Release of syngas to the atmosphere	Extremely Remote	Well below the ERPG – 2 limit. No health effects would be are anticipated.	For unprotected workers, health effects would be anticipated. However, workers are trained in emergency response, and personal protective equipment is available to reduce the potential of permanent health effects	No health effects to a non-involved worker would be anticipated.
Backflow of dodecane into the fluidized bed reactor, resulting in a fire and explosion	Extremely Remote	Facility walls would prevent any impacts to a member of the public.	Explosion and serious injury to the operators.	Facility walls would prevent any impacts to non-involved workers.
Failure of inerting in the off-gas system, resulting in a fire and explosion	Extremely Remote	Facility walls would prevent any impacts to a member of the public.	Detonation would do extensive damage to equipment. A fire could ensue.	Facility walls would prevent any impacts to non-involved workers.
TBPP and Upgraded TCUF (Proposed Action)				
Rupture of high-pressure line from synthesis reactor, resulting in a fire and atmospheric releases	Remote	Facility walls would be adequately designed to prevent any impacts to a member of the public.	Damage to the equipment would be considered minor. Accident would pose no danger to workers.	Facility walls would prevent any impacts to non-involved workers.
Loss of cooling to synthesis reactor, resulting in a fire and explosion	Extremely Remote	Facility walls would be adequately designed to prevent any impacts to a member of the public.	Explosion would cause extensive damage to the equipment and the facility. It is highly likely that some of the process piping would be damaged, and a fire would ensue. Because the annex is not occupied and is physically separated from the building containing the control room, injuries to workers are not anticipated.	Facility walls would prevent any impacts to non-involved workers.

a. A detailed explanation of accident probabilities is provided in Appendix B, Table B-2.

ERPG = Emergency Response Planning Guideline.

public exposure guidelines intended to predict how members of the public could be affected if exposed to a particular hazardous chemical. Typically, public guidelines are used for tasks such as toxic gas dispersion modeling and other kinds of consequence analysis, when the goal is to assess the severity of a hazard to the public (AIHA 2004).

The ERPG values provide estimates of concentration ranges where one reasonably might anticipate observing adverse effects (as described in the definitions for ERPG-1, ERPG-2, and ERPG-3) as a consequence of exposure to the specific substance:

- ERPG-1 maximum airborne concentration: it is believed that nearly all individuals could be exposed to the ERPG-1 maximum airborne concentration for up to 1 hour without experiencing other than mild transient adverse health effects or perceiving an objectionable odor.
- ERPG-2 maximum airborne concentration: it is believed that nearly all individuals could be exposed to the ERPG-2 maximum airborne concentration for up to 1 hour without experiencing or developing irreversible or other serious health effects or symptoms that could impair an individual's ability to take protective action.
- ERPG-3 maximum airborne concentration: it is believed that nearly all individuals could be exposed to the ERPG-3 maximum airborne concentration for up to 1 hour without experiencing or developing life-threatening health effects.

As can be determined from Table 3-5, of the accidents analyzed, only the spill or rupture of a 114-liter (30-gallon) drum of pyrolysis oil resulting in atmospheric release would have the potential to affect on-site workers in other STM facilities. This accident could occur under both the No Action Alternative and the Proposed Action. However, for the ERPG-2 limit to be exceeded, the concentration must be exceeded for 1 hour. Sheltering in place and effective emergency response measures should limit the exposure time to the non-involved workers to much less than 1 hour. Therefore, no permanent health effects would be anticipated for non-involved workers.

Under both the No Action Alternative and the Proposed Action, workers within the TCUF could be directly affected by exposures to hazardous releases, fires, or explosions under the postulated accidents, and serious injuries could occur. However, because the operations are conducted remotely, and workers have protective equipment and emergency response procedures, the likelihood of a serious injury to a TCUF worker is small.

Additionally, based on the accident analyses in Appendix B, DOE and NREL acknowledge that under Option 2 for the proposed TBPP, where an annex building would not be built, a failure of the synthesis reactor could result in injuries or fatalities to non-involved workers if they were struck by flying fragments. Even though the probability of such an accident is "extremely remote", such consequences are unacceptable. Therefore, this option has been eliminated from further consideration by DOE and NREL for the TBPP.

Until the final design is completed for the TBPP, DOE and NREL are unable to finalize the specific building design elements and containment structures that would mitigate the impacts of a catastrophic synthesis reactor failure accident. Prior to final design, NREL would initiate a Safety Assessment for the TBPP facility and associated activities to determine what additional levels of risk assessment are required. The final process design of the facility would dictate the risk assessment method selected. It is probable that either a process hazard analysis or a hazard analysis review would be employed. A process hazard analysis is a formal, systematic approach to identifying, evaluating, and mitigating process hazards and uses "What-If," "Hazard Operability Study," "Failure Mode and Effects Analysis," or "Fault Tree

Analysis” assessment methods. A hazard analysis review systematically identifies hazards, their probability of occurrence and severity, and the controls necessary to maintain the resultant risk at an acceptable level. Whichever method is selected appropriate subject matter experts would be involved. After the risk assessment methodology and the assessment team have been selected the analysis would be completed to quantify the risk that must be mitigated using a hierarchy of controls. These safety controls would include engineering design features, for example the possible addition of over pressurization building panels that release the pressure of an explosion to prevent catastrophic building damages, or structural containment of specific pieces of process equipment that would allow the release of excess pressure but contain large projectiles. These identified safety features would be integrated into the final facility design before construction begins.

Additionally, as required under DOE’s NEPA Implementing Regulations (10 CFR 1021.314), DOE and NREL will review the final TBPP design and compare it to the conceptual design assessed in the SEA and “determine whether there have been substantial changes to the proposal or significant new circumstances or information relevant to environmental concerns”, including mitigating the reactor failure hazard. This evaluation may be documented in a Supplement Analysis, or if substantial changes exist DOE may supplement the SEA.

3.1.4 Visual Quality/Aesthetics

3.1.4.1 Existing Environment

The text and figures describing the visual and aesthetic environment of the STM presented in the 2003 site-wide EA and 2007 EA remain current and are summarized below. Figures 3-8 and 3-9 illustrate the current overall visual environment at the STM complex as viewed from off-site locations south and east of the site.

The dominant visual characteristics of the existing STM site include the prominent slope and mesa top associated with STM; the DOE facilities located on top of STM; and the SERF, FTLB, S&TF, and Visitors Center located at the toe of the slope. The STM site buildings are prominent against the landscape of STM. Other less prominent buildings occupy the western end of the site.

The STM site facilities are designed to reflect the laboratory activities related to modern energy concepts. Three of the larger buildings—the SERF, FTLB, and S&TF—are terraced and set against the south slope of STM. In addition to the buildings at the STM central campus, DOE has constructed a variety of solar testing and measurement structures such as the High Flux Solar Furnace, Solar Radiation Research Laboratory, and numerous PV panels situated throughout the site.

3.1.4.2 Impacts of the Proposed Action

Research Support Facilities

The physical appearance and size of the proposed RSF would be similar to other buildings that have occupied portions of the STM site for years. For example, the height of the proposed RSF building(s) would not exceed five stories, or about 23 meters (75 feet) above ground level. This is comparable to the height of the nearby STM site facilities. The SERF, from ground level to the top of its exhaust stacks (the highest point), measures approximately 23 meters (73 feet) high, and its height to the top of the penthouse is approximately 19 meters (61 feet) above ground level. Similarly, the height of the S&TF is about 18 meters (59 feet) above grade.



Figure 3-8. Current View from a Location South of the STM Site



Figure 3-9. Current View from a Location East of the STM Site

Although the RSF would be a new facility, it would not adversely impact the overall visual characteristics of the site. The casual observer would likely notice only that the added development resembled the structures already on the site. DOE and NREL would select a design/build contractor for the RSF if a decision to proceed is made. No definitive conceptual design has been selected and a range of options in building sizes and locations could be proposed by prospective bidders. There would be some latitude for the design/build contractor in terms of location (see Figure 2-3); however, it is assumed that the RSF would be constructed on some combination of Building Pads 1, 2, and 3. Table 3-6 presents representative options in locations and building numbers and heights that would provide sufficient space for the staff that would be relocated to the RSF.

Figures 3-10 through 3-17 show simulated views of options defined in Table 3-6 for the proposed RSF. These simulations are representative of the relative size of the structures that might be built, but they may not be representative of the architectural style or the specific pad that would ultimately be selected. DOE and NREL would evaluate conceptual designs for their compatibility with existing structures at the STM site.

Figures 3-10 through 3-17 show that the options for building sizes and locations would generally be compatible with the overall STM site visual environment. However, a multi-story RSF constructed on Building Pad 1 would obstruct the view of the foothills for some residents of Kendrick Street located immediately east of the STM site boundary and south of Denver West Boulevard (see Figures 3-13 [Option B – From East] and 3-17 [Option E – From East]).

Table 3-6. RSF Height and Location Options

Option	Simulation Viewed From	Figure Number	Number of Buildings	Figure 2-3 Location	Height in feet (number of stories) ^a
A	South	3-10	1	Pad 1	15 (1)
			1	Pad 2	45 (3)
			1	Pad 3	60 (4)
B	East	3-11	1	Pad 1	15 (1)
			1	Pad 1	15 (1)
B	South	3-12	1	Pad 1	75 (5)
			1	Pad 2	60 (4)
			0	Pad 3	NA
B	East	3-13	1	Pad 1	75 (5)
			1	Pad 1	75 (5)
C	South	3-14	0	Pad 1	NA
			1	Pad 2	60 (4)
			1	Pad 3	60 (4)
D	South	3-15	0	Pad 1	NA
			1	Pad 2	45 (3)
			1	Pad 3	75 (5)
E	South	3-16	1	Pad 1	30 (2)
			1	Pad 2	45 (3)
			1	Pad 3	60 (4)
	East	3-17	1	Pad 1	30 (2)

a. One story equals approximately 15 feet.



Figure 3-10. Option A – From South



Figure 3-11. Option A – From East



Figure 3-12. Option B – From South



Figure 3-13. Option B – From East



Figure 3-14. Option C – From South



Figure 3-15. Option D – From South



Figure 3-16. Option E – From South



Figure 3-17. Option E – From East

Site Infrastructure Improvements and TCUF Upgrades

Due to their limited size and their locations, the proposed site infrastructure improvements, the TBPP, and the TCUF upgrades would not result in discernible visual or aesthetic impacts. The parking areas and their retaining walls, covered bus stops, and lighting, while visible from off-site locations, would not be visually inconsistent with the existing STM facilities, and may be visually integrated through the use of color and texture in building materials and landscape plantings. The RSF construction access road would be a temporary visual impact to offsite locations, which would be eliminated after the effects of the planned reclamation efforts were realized.

3.1.5 Water Resources

3.1.5.1 Existing Environment

The description of water resources found in the site-wide EA remains current and is summarized below.

Surface Water

There are no perennial creeks, streams, ponds, or floodplains on the STM site. Surface water, when present, is not used by NREL. There may be seasonal seeps on the STM site after small amounts of surface water percolate through the soil or the fractured basalt that caps STM. Intermittent storms and other seasonal precipitation events may cause water to temporarily collect in topographic lows and drainages.

Groundwater

Groundwater monitoring is not required of NREL by a regulatory agency; however, monitoring wells were installed at the STM site, and groundwater baseline data were accumulated beginning in 1990. Many of the monitoring wells have since been capped. The most recent groundwater monitoring data were obtained in 1997. That year, groundwater beneath the site was analyzed for volatile organic compounds (VOCs), semivolatile organic compounds (SVOCs), total metals, pesticides, and herbicides. Results of the analysis indicated that the groundwater beneath STM is uncontaminated for VOCs, SVOCs, pesticides, and herbicides. The samples indicated that concentrations of manganese and iron were elevated; however, the concentrations were within naturally occurring variations and no constituent concentrations exceeded national primary drinking water standards.

3.1.5.2 Impacts of the Proposed Action

RSF and Site Infrastructure Improvements

Neither the proposed RSF nor the proposed site infrastructure improvements would result in untreated operational discharges of pollutants to surface water or groundwater. New drains, stormwater detention basins, and conveyance structures would be connected to the site's existing stormwater and sewage lines or to other existing publicly owned water discharge and treatment works. All discharges to publicly owned treatment works would meet the requirements of the Metro Wastewater Reclamation District and the Pleasant View Water and Sanitation District. Workers who would be housed in the proposed RSF currently work at the DWOP, and this leased office space would presumably be backfilled with new, non-DOE tenants when DOE vacated the premises. The new backfilled workers at the DWOP could represent a new demand on local or regional water supplies and sewage disposal capacities, depending on where the backfilled personnel currently work (also see Section 3.1.12, Public Services and Utilities).

Absent engineered mitigation measures, construction of the RSF, the new parking lots, and the new paved roads would increase quantities of runoff conveyed off-site and consequently could incrementally degrade down-slope surface water quality. Increased turbidity and quantities of various chemicals associated with incidental leaks from additional vehicles and construction equipment would occur. Increased runoff could increase localized on-site flooding. Absent mitigation measures, the estimated volume of increased runoff over current runoff would be approximately 12 acre-feet per year, most of which would be additional runoff from the new parking lots. This rough estimate of increased runoff in the absence of mitigation measures is based on the following assumptions, using standard runoff coefficients:

- approximately 4 hectares (10 acres) of new parking lots,
- approximately 1.4 hectares (3.5 acres) for the RSF and associated amenities (walkways, landscaping, interaction areas, etc.), and
- less than 0.4 hectare (1 acre) for the new roads.

The estimate assumes one event based on Denver’s historical average precipitation of 40.1 centimeters (15.78 inches) per year. The estimate does not address natural factors that could reduce runoff and mitigate the impacts of increased runoff, including the fact that precipitation occurs as multiple events throughout the year rather than a one-time event, the duration and intensity of events, land slope, soil infiltration rates, and local evaporation rates.

To mitigate impacts from increased runoff, DOE would install a new detention basin or a series of basins in or around the central drainage dry stream channel to minimize and manage off-site runoff from the Proposed Action. In addition, DOE would re-grade the surrounding terrain and/or install engineered drainage systems to direct runoff from the proposed parking lots into the new detention basins. This would be a “committed to” measure. Stormwater impacts would be further minimized by complying with the provisions of NREL’s U.S. Environmental Protection Agency (EPA)-issued National Pollutant Discharge Elimination System (NPDES) General Permit for construction activities.

The RSF construction access road would cross two or more dry stream channels and require culverts or other structures to permit the unimpeded flow of runoff during storm events. All such structures would be adequately sized to meet the needs of construction vehicles and accommodate site runoff.

If groundwater were encountered during excavations for the RSF, it would be pumped from the excavation to a vegetated area rather than directly into a natural drainage. The vegetated areas would act as filters to trap sediment and reduce impacts to surface water.

TCUF Upgrade and TBPP

The addition of the TCUF upgrade and TBPP unit operations would necessitate an increase in water demand of approximately 5,678 liters (1,500 gallons) per year for evaporative cooling. There would be no discharges to surface water or groundwater associated with these activities. No new wastewater discharges to the Publicly-Owned Treatment Works are anticipated.

3.1.6 Biological Resources and Wetlands

3.1.6.1 Existing Environment

The descriptions of biological resources and wetlands found in the site-wide EA remain current and are summarized below. These descriptions relied upon reporting and fieldwork performed by various

consultants at the STM site over 16 years, as well as fieldwork conducted in May 2002. Additional biological resource information is available in the following reports:

- Wildlife Survey (Including Migratory Birds and Raptors) at the National Renewable Energy Laboratory South Table Mountain Site, Golden, Colorado (NREL 2005);
- Vegetation Survey, NREL South Table Mountain Site (NREL 2002);
- South Table Mountain Site Conservation Easement Baseline Inventory (NREL 1999).

Located at the base of the foothills to the Rocky Mountains, the STM site occurs at elevations ranging from 1,760 meters (5,780 feet) to 1,840 meters (6,030 feet) above mean sea level. This coincides with the interface between two ecological provinces: the Great Plains-Palouse Dry Steppe Province to the east, and the Southern Rocky Mountain Steppe – Open Woodland – Coniferous Forest – Alpine Meadow Province to the west.

The Proposed Action that is the subject of this final SEA would occur on NREL land with one predominant vegetation type and one very small non-jurisdictional wetland. As seen in Figure 3-8 of the site-wide EA, the construction that would occur as part of the Proposed Action would occur in Development Zones 6 and 4, where the vegetation is mixed grass. Mixed grass vegetation occupies approximately 30 percent of the vegetation at the STM site. As shown in Figure 3-9 of the site-wide EA, one very small wetland (designated STM-10) occurs in the northeast quadrant of Development Zone 6. This wetland is approximately 9 square meters, or just over 0.002 acre. It is Palustrine emergent, a wetland type that would typically support hydrophytic vegetation such as cattails (*Typha latifolia*), Nebraska sedge (*Carex nebrascensis*), slender sedge (*Carex praegracilis*), and Canada thistle (*Breca arvensis*). The far western border of RSF Building Pad 1 lies near this wetland.

Wildlife habitat at the STM site is almost exclusively grassland and shrubland. The Colorado Division of Wildlife (CDOW) has estimated that these habitats may support up to 14 reptile species, 36 mammal species, 82 bird species, and 4 amphibian species.

A wildlife study of the STM was conducted in 1987. The demographics of the area surrounding the STM site have changed since that study, and additional development of the STM site has since occurred. At the request of NREL, Science Applications International Corporation began a four-season wildlife survey of the STM site in the spring of 2004 to update the 1987 data. The 2005 wildlife survey (NREL 2005) is incorporated into this final SEA by reference. The wildlife survey also includes recommendations for consideration during normal site operations and future construction projects to minimize adverse impacts to wildlife. These recommendations would be reviewed and implemented to the fullest extent possible before and during implementation of the Proposed Action.

Wildlife species observed during site surveys include migratory birds and raptors, large and small mammals (including predator species), reptiles, and amphibians.

Species of Concern

For this final SEA, a species of concern is defined as those species protected under federal statute, including the Endangered Species Act of 1973, as amended; the Bald Eagle Protection Act of 1940, as amended; and the CDOW list of endangered, threatened, and wildlife species of concern. Federal agencies are also required to abide by the Migratory Bird Treaty Act of 1918, as amended.

The 2005 survey included a review of the U.S. Fish and Wildlife Service (USFWS) list of proposed, endangered, threatened, experimental, and candidate species and habitat (USFWS 2004) and the CDOW list of endangered, threatened and wildlife species of special concern (CDOW 2003) for species observed on the STM site. No species observed on the STM site during the 1987 or the 2004-2005 wildlife surveys were present on either agency's list. However, golden eagles were incidentally observed on the STM site (outside of raptor surveys) and are protected under the Bald Eagle Protection Act. Golden eagles were observed flying over the site and may use the site for hunting. No golden eagle nests or nesting activities were observed on the STM site.

3.1.6.2 *Impacts of the Proposed Action*

RSF and Site Infrastructure Improvements

The RSF and site infrastructure improvements would be located largely on undeveloped land in Development Zone 6 and west of the Visitors Center in Development Zone 4. Land clearing, excavation, construction, and paving would essentially eliminate any value of up to 7 hectares (17 acres) of this land as habitat for wildlife or any vegetation other than noxious weeds. Additionally, the construction access road to the RSF would temporarily remove up to 1.2 hectares (3 acres) of habitat for up to 2 years, after which time the area would be reclaimed and again become viable habitat for wildlife.

Land clearing would destroy or disturb existing native vegetation, making the areas more susceptible to noxious weed invasion if the land were not subsequently paved over or used for building construction. Noxious weeds such as Canada thistle, diffuse knapweed, musk thistle, houndstongue, field bindweed, common teasel, jointed goatgrass, and dalmatian toadflax occur on the site and are found on either the list of the 10 most widespread noxious weeds in the State of Colorado or on Jefferson County's list of noxious weeds of concern. The potential spread of these species, as well as cheatgrass and 12 other noxious weed species found at the STM site, into disturbed areas represents secondary impacts as a result of the Proposed Action. NREL has made efforts to combat noxious weed invasion. These efforts include implementation of a noxious weed management plan which, among other strategies, calls for a native grassland seed mix to be used in restoration areas after construction.

TCUF Upgrade and TBPP

Because the proposed TCUF upgrade and the TBPP would occur within the existing FTLB and in an underutilized loading dock area adjacent the FTLB, there would be no impact to biological resources or wetlands.

3.1.7 Cultural Resources

3.1.7.1 *Existing Environment*

There are no known significant prehistoric archaeological resources within or adjacent to the NREL STM property. There are no known significant traditional cultural resources within or adjacent to the STM site. Should any evidence of archaeological or cultural resources be discovered at any time during any ground-disturbing activities at the STM site, all work would stop in the vicinity until a qualified archaeologist completely evaluated the significance of the find according to criteria established by the National Register of Historic Places.

The Proposed Action would entail development in Zone 6, the 10-hectare (25-acre) Camp George West parcel. This parcel lies within a portion of the Camp George West Historic District, which was deemed

eligible for listing in the National Register of Historic Places (National Register) on May 18, 1987, by the Colorado State Historic Preservation Officer (SHPO), as part of the determination of eligibility for the larger Camp George West complex. The complex, in its entirety, is defined by the boundaries of all lands historically utilized by the Colorado Army National Guard for its activities at the Camp George West installation. The registered district is listed on the basis of its historical significance and association with the military development of the area during a portion of World War I and the duration of World War II. The district, also known as the “State Rifle Range,” includes portions of the former Colorado Army National Guard complex located south of Denver West Parkway. The range was used heavily during World War I and World War II for intense training, target practice, marching, tank operation, and tactical exercises.

Figure 3-18 shows the locations of the firing ranges in Zone 6.



Figure 3-18. Firing Lines and Targets on NREL’s Camp George West Property

3.1.7.2 Regulatory Background and SHPO Consultations

A cultural resources survey of Zone 6 was conducted in 2002. The survey confirmed the existence of two contributing features to the Camp George West Historic District within the zone. The contributing resources are:

- Camp George West Firing Range Lines (Site No. 5JF.145.66),
- Camp George West Low Rock Walls (Site No. 145.68).

Both resources are engineered features, and both are expected to be adversely affected by the Proposed Action—specifically, by construction of the three parking lots in Zone 6.

On October 10, 2002, DOE sent a letter to the Colorado SHPO asking for concurrence on DOE’s determination of effects for proposed developments on the Camp George West Parcel. The letter summarized the resources known to exist within the parcel and requested concurrence on the determination of an adverse effect on an historical resource for the Proposed Action (development within Zone 6) as presented in the site-wide EA (DOE 2003). On July 1, 2003, a FONSI was issued by DOE based upon the completion, review, and public circulation of the site-wide EA.

Based on information documented in the October 2002 letter submitted to the SHPO by the DOE, and in conjunction with the FONSI, the SHPO and DOE entered into a Memorandum of Agreement (MOA) that would guide investigations necessary to comply with Section 106 of the National Historic Preservation Act (NHPA), as amended (16 U.S.C. 470f), and implementing regulations codified at 36 CFR Part 800. The MOA was signed on August 5, 2003. The MOA stipulates that Historic American Building Survey/Historic American Engineering Record (HABS/HAER) documentation be completed prior to conducting development that could adversely affect historic resources located within the Camp George West Parcel. These two resources were determined by the SHPO to contribute to the Camp George West Historic District's eligibility to the National Register.

Pursuant to and in compliance with the MOA, DOE completed background research and Level II HABS/HAER documentation¹ in May and June 2005. In January 2006, the Camp George West Level II HABS/HAER documentation (originally dated August 2005) was revised to include field drawings of the "low rock wall" as requested by the Colorado SHPO. This was the final report submitted to the SHPO. It is on file with the Colorado SHPO and also at the DOE Golden and NREL offices. The SHPO has neither recommended nor required that DOE implement further impact mitigation measures.

3.1.7.3 *Impacts of the Proposed Action*

Zone 6

The proposed developments in Zone 6 would result in unavoidable adverse impacts to historical resources. The improvements would result in the destruction of the two firing lines and all or portions of the low rock wall. This unavoidable adverse impact has been mitigated through consultations with the SHPO and the preparation of Level II HABS/HAER documentation of these historical resources.

RSF, TCUF Upgrade, TBPP, and Site Infrastructure Improvements

The proposed RSF, TCUF upgrades, TBPP, and infrastructure improvements in Zone 4 would occur in areas that have been surveyed and where no cultural or historic resources are known or believed to exist. No impact to cultural or historical resources is anticipated. However, if during the course of construction any cultural or historic resources were discovered, work in that area would be immediately halted pending consultations with a qualified state or tribal archaeologist or historian and, if necessary, the SHPO.

3.1.8 *Air Quality*

3.1.8.1 *Existing Environment*

Detailed descriptions of the existing air quality at the STM are provided in the site-wide EA. These descriptions address climate (Section 3.3.1), air quality regulatory authorities (Section 3.3.2), emissions sources (Section 3.3.3), and STM site permit status (Section 3.3.4). They remain generally current and are summarized or updated below.

¹ Level II documentation is the required method for creating archival records of and for previously identified properties of significance when impacts to a site must be mitigated due to impending loss. Level II documentation consists of an intermediate level of site documentation that includes a full description of the resource, a historical narrative addressing relevant historic contexts, measured drawings, and black and white photography, all in an archivally stable format.

The STM site has numerous stationary sources of air emissions, including: boilers, water heaters, back-up generators, building heaters, and the existing TCUF. Table 3-7 shows the STM site's potential to emit and estimated actual annual emissions of major air pollutants. In addition, with respect to hazardous air pollutants, the STM site emits extremely small quantities of materials from laboratory hoods. Examples of these hazardous air pollutants include: aliphatic and aromatic hydrocarbons, chlorinated and non-chlorinated compounds, inorganic acids, alcohols, and noble gases. The emission quantities are below notification and permit thresholds. Fugitive emissions also can occur from the STM and DWOP sites as unplanned emissions from miscellaneous routes other than stacks, chimneys, or vents. These emissions are minor. Construction activities at the STM site have the potential to increase fugitive dust levels by disturbing soil.

Table 3-7. STM Site Estimated Annual Air Pollutant Emissions

Type of Air Emission	Particulates	SO ₂	NO _x	CO
	Tons per Year (TPY)			
Potential	7.96	5.76	51.61	24.61
Estimated Actual ^a	4.41	0.59	9.35	4.97

- a. Includes projected emissions from Renewable Fuel Heating Plant, which was assessed in DOE 2007 and is expected to begin operations in late 2008.
Sources: NREL 2001, as updated for 2007.
DOE 2007.

3.1.8.2 Impacts of the Proposed Action

National Ambient Air Quality Standards (NAAQS) set upper concentration limits for six air pollutants in order to protect human health. These six pollutants are called criteria air pollutants. They are CO, nitrogen oxides (NO_x), ozone (O₃), particulate matter (PM), sulfur dioxide (SO₂), and lead (Pb). Geographic areas that currently exceed or have recently exceeded the limit for one or more of the criteria air pollutants (or for O₃ precursors) are called nonattainment areas or maintenance areas. The two O₃ precursors are VOCs and NO_x. Section 3.1.8.3 (Conformity Review) discusses criteria air pollutant emissions attributable to the Proposed Action in further detail.

RSF and Site Infrastructure Improvements

Construction would cause a temporary increase in emissions of criteria air pollutants from construction equipment exhaust emissions. Construction of the new parking lots and service roads and installation of underground utilities would involve scraping and grading, which would result in intermittent fugitive dust emissions during construction. Dust would be controlled or reduced by spraying and other techniques. Because NREL staff who would be housed in the proposed RSF currently commute to the DWOP located just off-site, there would be little net change in emissions due to staff vehicles, assuming no major increase in vehicle idling time due to traffic backups. However, DOE acknowledges that a small increase in commuter vehicle emissions may occur because the DWOP would presumably be backfilled with new, non-DOE tenants when DOE vacated the premises. The proposed shuttle bus service could result in minor additional air emissions from the site during workday hours, depending on the type of fuel used and the frequency of service. Air emissions from the proposed RSF would be limited to those characteristic of HVAC equipment and operating emissions from commercial office buildings. Because construction-related emissions would be short-term and shuttle bus emissions would be very minor, no adverse health impacts to on-site workers or the public or adverse visibility impacts to the local or regional viewshed would result from air emissions due to the proposed RSF and site infrastructure improvements.

TCUF Upgrade and TBPP

For State of Colorado permitting requirements, a major stationary source is one that has the potential to emit, when operated at maximum load for 8,760 hours per year (i.e., 24/7), more than 100 tons per year (TPY) of any criteria air pollutant, or more than 5 TPY of any hazardous air pollutant. NREL is not currently a major source, and the major source permitting requirements do not apply. Operating permits may be issued for sources with thresholds under 100 TPY; these are called minor sources. DOE holds a permit to operate the TCUF in its current configuration for up to 50 TPY of biomass throughput. Historically, TCUF operations have not exceeded 7 TPY of biomass throughput, and it is estimated that the proposed TCUF upgrades and TBPP would not exceed a maximum throughput of more than 50 TPY of biomass. When full details of emission increases, if any, associated with the proposed TCUF upgrades and TBPP are available, DOE/NREL would file an Air Pollution Emission Notice and permit application/revision package with the Colorado Department of Public Health and Environment (CDPHE), if so required by the current permit. Based on the projected operating parameters of the proposed TCUF upgrades and TBPP, DOE/NREL does not anticipate that incremental emissions from the proposed activities would result in NREL exceeding any current regulatory limits or current permit requirements.

3.1.8.3 Conformity Review

Section 176(c)(1) of the Clean Air Act requires that federal actions conform to applicable state implementation plans (SIPs) for achieving and maintaining the NAAQS for the criteria air pollutants. In 1993, the EPA promulgated a rule titled “Determining Conformity of General Federal Actions to State or Federal Implementation Plans” (58 Fed. Reg. 63214 (1993)), codified at 40 CFR Parts 6, 51, and 93. The “conformity rule” is intended to ensure that emissions of criteria air pollutants and their precursors are specifically identified and accounted for in the attainment or maintenance demonstration contained in SIPs. For there to be conformity, a federal action must not contribute to new violations of air quality standards, increase the frequency or severity of existing violations, or delay timely attainment of standards in areas of concern.

The conformity rule applies to non-exempt, federal actions that would cause emissions of criteria air pollutants (or their precursors) above EPA’s established threshold levels (de minimis levels) in designated nonattainment or maintenance areas. Under the rule, an agency must engage in a *conformity review* and, depending on the outcome of that review, conduct a *conformity determination*. In a conformity review, the federal agency must (1) determine whether a proposed action would cause emissions of criteria pollutants or their precursors, (2) determine whether the emissions would occur in a nonattainment or maintenance area for any of the criteria air pollutants, (3) determine whether the proposed action is exempt from the conformity rule requirements, (4) estimate the emission rates of criteria air pollutants impacting a nonattainment or maintenance area, and (5) compare the estimate to the applicable threshold emission rates. If the estimated emission rates are below the threshold, the proposed action is assumed to conform and no further action is required. If they exceed the threshold, a more detailed conformity determination is required.²

DOE conducted a conformity review for the Proposed Action and determined that (1) the Proposed Action would result in emissions of criteria air pollutants, and (2) these emissions would occur in an area

² Previously, a conformity review would also entail comparing estimated emissions in a nonattainment or maintenance area to regional inventories to ensure that estimated emissions were not “regionally significant”. However, in its proposed revision to the general conformity rule (73 FR 1402; January 8, 2008) EPA proposes to delete the requirement in 40 C.F.R. 93.153(i) relating to regionally significant actions in part because in over twelve years since promulgation of the existing regulations, no action has been determined to be regionally significant.

(Jefferson County, Colorado) that the EPA has designated as a moderate nonattainment area for O₃ and a maintenance area for CO and PM. Consequently, DOE conducted a further review of estimated emissions of these criteria air pollutants to determine the applicability of the general conformity rule and to determine if the estimated rate of these emissions would be less than or greater than the allowed thresholds.

The threshold emission rates for a moderate ozone nonattainment area is 100 TPY of NO_x or VOC; the threshold emission rates for CO and PM in a CO or PM maintenance area are also 100 TPY (40 CFR 93.153).

Operational Emissions

Operation of the proposed upgrade to the TCUF, the TCUF high bay area, and the proposed TBPP would result in a small increase in emissions of VOCs (e.g., acetone, cyclohexane, toluene, xylene, and similar volatile organics) from hoods and other sources. These emissions are currently below the 1 ton per year permitting threshold for hazardous air pollutants. Criteria pollutants from the existing thermal oxidizer would increase with increased hours of operation. These emissions are permitted under NREL's CDPHE Air Permit # 99JE0400, which regulates and authorizes air emissions from the TCUF. Any increase in emissions due to the Proposed Action would be within currently authorized levels. The general conformity rule ((40 CFR 93.153(d)) exempts portions of an action that require an air emissions permit because state-permitted emissions are presumed to conform to the applicable SIP. DOE has determined that because criteria pollutant emissions from operation of the proposed upgrades to the TCUF, the TCUF high bay area, and the TBPP would be permitted under CDPHE # 99JE0400, they are exempt from the need for further conformity determination.

Construction Emissions

Construction associated with the Proposed Action would result in localized, short-term increases in ambient concentrations of CO, NO_x, and PM. These emissions would result from operation of construction equipment engines and from fugitive dust mobilized during earth moving and grading, material handling and storage, and vehicles traveling over temporary dirt and gravel access roads. Given the small area of the proposed construction sites, the proximity to paved roads, and the anticipated short duration of the construction, potential impacts would be local and temporary. Construction impacts would be minimized through the use of best management practices, such as wetting the soil surfaces, covering trucks and stored materials with tarps to reduce windborne dust, and using relatively late-model, properly maintained construction equipment.

Emissions of construction-generated fugitive dust would be permitted under NREL's CDPHE Air Permit # 04JE1443L, which authorizes emissions of fugitive dust at the STM site associated with overlot grading and associated construction activities. The general conformity rule ((40 CFR 93.153(d)) provides an exemption for portions of an action that require an air emissions permit because state-permitted emissions are presumed to conform to the applicable SIP. DOE has determined that because PM emissions from construction-generated fugitive dust would be permitted under CDPHE Permit # 04JE1443L, they are exempt from the need for further conformity determination.

The Proposed Action also includes construction activities that would result in emissions of CO, NO_x, and PM primarily from diesel engines. EPA has published exhaust and crankcase emission factors for steady-state emission of CO, NO_x, and PM from off-road diesel engines (EPA 2004). Table 3-8 shows these emission factors for Tier 1 engines of various power ranges. Tier 1 standards were adopted in 1994 for

Table 3-8. Tier 1 Steady-State Emission Factors for Nonroad Diesel Engines

Engine Power (hp)	Tier 1 Technology-Type Emission Factors (g/hp-hr)		
	CO	NO _x	PM
>50-75	2.3655	5.5988	0.4730
>75-100	2.3655	5.5988	0.4730
>100-175	0.8667	5.6523	0.2799
>175-300	0.7475	5.5772	0.2521
>300-600	1.3060	6.0153	0.2008

Note: hp = horsepower; g/hp-hr = grams per horsepower per hour.
Source: EPA 2004.

engines over 50 horsepower and were phased in from 1996 to 2000. EPA cites these emission factors as technical documentation its final NONROAD2005 emissions model (EPA 2005).

The exact types and numbers of engines that would be used for the Proposed Action and their total hours of operation are not yet known. However, based on a review of recent, similar construction projects at the STM site and at other DOE sites, DOE developed a list of the types and sizes (horsepower ranges) of equipment types that is believed to be representative of those that would be used for the Proposed Action (Table 3-9). Table 3-9 also shows DOE's estimate of the hours that each type of equipment would operate during implementation of the Proposed Action. The emission factors shown in Table 3-8 were applied to develop the estimates of the annual emissions of NO_x, CO, and PM shown in Table 3-9.

The estimated annual emissions of each of these criteria air pollutants are well below the 100-TPY thresholds. Moreover, DOE believes these estimates are conservative for the following reasons: (1) the calculations assume the highest engine horsepower shown in the engine size range, (2) the calculations assume Tier 1 technology, and at least some of the equipment used would probably employ more stringent (lower-emitting) Tier 2 through 3 technology, and (3) the estimates of operating hours are conservatively high.

Because the estimated emissions of CO, NO_x, and PM from construction activities would be below the de minimis thresholds, DOE has determined that further conformity determination is not required. DOE acknowledges that there would likely be additional miscellaneous sources of CO, NO_x, and PM directly or indirectly attributable to the Proposed Action. For example, depending on its fuel source, the proposed shuttle bus service to the new parking lot areas could be an air emission source, as would commuting construction workers and the use of equipment types not specifically identified in Table 3-9. While recognizing and acknowledging these potential additional incremental sources, DOE believes they would not result in the Proposed Action exceeding allowed threshold levels because they would be either short-term (commuting workers) or limited in their potential to emit (shuttle bus, limited use of other diesel or gasoline equipment).

3.1.9 Geology and Soils

3.1.9.1 Existing Environment

The detailed descriptions of the site geology and soils found in the site-wide EA remain current and are summarized below.

The STM is located on the gently sloping terrain of the Foothills Province of the Rocky Mountain Front Range between the Southern Rocky Mountain Province to the west and Great Plains Province to the east.

Table 3-9. Estimated CO, NO_x, and PM Emissions from Diesel Construction Equipment

Major Construction Source	No. of Units	Engine Size Range (hp)	Total Operating Hours/Yr	Estimated Annual Emissions (TPY) ^a		
				CO	NO _x	PM
Portable Lighting	3	50-100	480	0.13	0.30	0.03
Portable Generator	1	50-100	640	0.17	0.39	0.03
Backhoe/Loader	3	50-100	1,920	0.50	1.18	0.10
Forklift	3	50-100	1,920	0.50	1.18	0.10
Asphalt Paver	1	100-175	80	0.01	0.09	0.004
Asphalt Roller	1	100-175	80	0.01	0.09	0.004
Compactor	2	100-175	160	0.03	0.17	0.01
Concrete Pumper	3	100-175	240	0.04	0.26	0.01
Water Tanker	1	100-175	320	0.05	0.35	0.02
Excavator	2	100-175	640	0.11	0.70	0.03
Bulldozer	2	175-300	640	0.16	1.18	0.05
Motor Grader	2	175-300	640	0.16	1.18	0.05
Wheel Loader	3	175-300	1,920	0.47	3.54	0.16
Crane – 35-ton	2	175-300	1,280	0.32	2.36	0.11
Concrete Truck	2	175-300	960	0.24	1.77	0.06
Scraper	2	300-600	640	0.55	2.55	0.08
Dump Truck	4	300-600	2,560	2.20	10.18	0.34
Crane – 50-ton	2	300-600	1,280	1.10	5.09	0.17
Total Estimated Emissions (TPY)				6.7	32.6	1.4
De Minimis Threshold (TPY)				100	100	100

a. Example calculation: CO emissions from portable lighting units:
(2.3655 grams of CO/hp-hr) x (100 hp) x (480 hours/yr) / 907,185 grams/ton = 0.13 TPY

Denver clay loam and Denver cobbly clay loam dominate the soils at STM site where the proposed new facilities would be constructed. The STM site is classified as being in Seismic Zone 1, an area of low seismic risk. Structures to be built on the STM site would meet the most current Uniform Building Code standards appropriate for its designated seismic zone.

3.1.9.2 Impacts of the Proposed Action

Potential geological impacts would closely resemble the geological impacts presented in the site-wide EA, which specifically considered construction of the S&TF and other comparable site developments. With the exception of the new water detention basins in or near the central drainage dry stream channel, all elements of the Proposed Action would be constructed on relatively flat terrain. An area of up to 7 hectares (17 acres) would be either paved over for parking and a new on-site road or excavated for construction of the RSF.

Prior to construction, the new construction areas would be excavated and graded as needed. Materials such as concrete aggregate and crushed rock would be required during construction of the RSF. These

materials would be obtained from off-site commercial sources or may involve use of material from on-site excavations. Excavation may occur below the alluvial surface. Excavation could conceivably go below the alluvium if reaching bedrock for stability were necessary. It is unlikely that any construction associated with the Proposed Action would increase landslide potential anywhere on the STM site because there is no evidence of recent landslides on the south side of STM, and no on-site or off-site construction in the immediate vicinity of the STM site has caused slope instability.

3.1.10 Waste Management

3.1.10.1 Existing Environment

The descriptions of the existing waste management environment found in the site-wide EA remain generally current and are summarized or updated below.

The STM generates a variety of hazardous and nonhazardous wastes from laboratory and mission support activities. All waste-handling and disposal activities comply with the requirements and regulations of the Occupational Safety and Health Act (OSHA), the Resource Conservation and Recovery Act, DOE, and the CDPHE. All hazardous wastes are packaged and disposed of through contracted off-site commercial treatment, disposal, and recycling firms. Many of the hazardous wastes generated on-site are recycled in accordance with CDPHE regulations, including such items as batteries, fluorescent bulbs, and computer monitors. As a best management practice (BMP), many of the nonhazardous waste materials (nonregulated waste) generated at the sites are treated in the same manner as the hazardous wastes. These materials, although not classified as hazardous, are also recycled or disposed of at off-site commercial treatment, storage, disposal, and recycling facilities.

Historically, NREL has been a small-quantity waste generator, which means that the facility has generated more than 100 kg (220.5 lbs) but less than 1,000 kg (2,205 lbs) of hazardous waste per month. However NREL anticipates that it will become a large-quantity generator in 2008. Large-quantity generators generate more than 1,000 kg (2,205 lbs) of hazardous waste, or more than 1 kg (2.2 lbs) of acutely hazardous waste, per month.

The STM site does not maintain an on-site waste disposal facility. Waste is shipped to licensed off-site disposal facilities. Table 3-10 shows the amount of hazardous waste generated at the STM site in recent years and illustrates that on average for the last five years, the TCUF has generated more than 75 percent of the hazardous waste generated at the STM site.

Table 3-10. Hazardous Waste Generation, 2003-2007

	Amount Generated (gross weight in lbs)				
	2003	2004	2005	2006	2007
STM Site	18,627	18,124	41,948	17,187	22,280
TCUF	15,490	14,683	36,415	10,070	16,235

Note: To convert pounds to kilograms, multiply by 0.45.

3.1.10.2 Impacts of the Proposed Action

RSF and Site Infrastructure Improvements

Construction would be short-term (less than 18 months) and would not substantially increase the amounts or types of waste generated or temporarily stored at the site. In the case of a spill or release of chemicals or hydrocarbons during construction activities, existing BMPs and procedures associated with spill response and materials handling would minimize impacts to surface water and soils. These procedures are defined in the NREL *Spill Prevention Control and Countermeasures (SPCC) Plan* for the STM (NREL, 2006b) (Procedure 6.2-10). Any construction debris that could not be recycled would temporarily increase the weight and volume of nonregulated waste generated at the site. The RSF and new infrastructure operations would not generate hazardous waste, nor would they result in a significant increase in nonregulated waste over and above the amounts of nonregulated waste currently generated at the leased office space that the RSF would replace.

TCUF Upgrade and TBPP

Construction would be short-term (less than 18 months) and would not substantially increase the amounts or types of waste generated or maintained at the site. The proposed upgraded TCUF operations and TBPP would result in an increase of approximately 11,340 kg (25,000 lbs) of hazardous mixed alcohol waste (approximately 13,627 liters [3,600 gallons] > 90 percent alcohol), and approximately 726 kg (1,600 lbs) of non-hazardous scrubber media waste annually.

3.1.11 Noise

3.1.11.1 Existing Environment

Detailed descriptions of the existing noise environments at the STM are provided in the site-wide EA. These descriptions address sensitive noise receptors (Section 3.4.1), existing noise levels (Section 3.4.2) and noise regulations and guidelines (Section 3.4.3). They remain current and are summarized below.

Noise receptors located in the immediate vicinity of the STM site include STM personnel, inhabitants of residences east and south of the site boundary, and wildlife. With respect to NREL personnel, DOE has accepted the Occupational Safety and Health Administration (OSHA) noise regulations and guidelines for worker exposure and manages compliance with them. These regulations and guidelines focus on noise from machinery, equipment, and tools. DOE maintains compliance with all regulations related to worker health and safety.

Receptors in the vicinity of the site include inhabitants of multi-family residences located approximately 15 meters (50 feet) east of the site boundary. Two subdivisions composed of single-family residences are located south of the STM site. The nearest residence to the site's southwestern boundary is located approximately 15 meters (50 feet) away. The nearest residence to the site's southeastern boundary is located approximately 30 meters (100 feet) away. The nearest school, church, or day-care center is about one-half mile from the site, near 20th and Denver West Parkway. There is a partially completed regional park in the open area south of Zone 6.

Although noise measurements were not taken for the site-wide EA and noise modeling was not performed, site observations indicate that the acoustic environment within the boundaries of the southeastern portion of the site can be considered similar to that of an urban location. I-70 is a significant noise source throughout the day and during sensitive late-night and early-morning periods. It is estimated that 24-hour day-night average sound levels on the site typically range from 40 to 60 A-weighted decibels

(dBA). Most activity and mechanical operations at the STM site are conducted within buildings. Construction activity and routine maintenance occasionally generate noise.

The State of Colorado Noise Statute (Code of Colorado Regulations [CCR] 25-12-101 through CCR 25-12-109) has established state-wide standards for noise level limits for various time periods and areas. These standards can be used as guidelines for evaluating impacts. The most stringent permissible noise levels apply to residential zones, where the maximum permissible daytime (7 a.m. to 7 p.m.) noise level is 55 dBA measured at a distance of 8 meters (25 feet) from the property line. In addition, construction projects are limited to permit conditions or 80 dBA for the period within which the construction is to be completed or a reasonable amount of time.

3.1.11.2 Impacts of the Proposed Action

Construction

Construction would normally occur Monday through Friday during daylight hours. The exception would be in cases where construction activity required interruption of site utility services; in that case, weekend work may occur. There would be a short-term (approximately 18 months) increase in ambient noise due to construction of the RSF, the site infrastructure improvements, the TCUF upgrades, and the TBPP. Heavy equipment such as bulldozers, graders, backhoes, excavators, dump trucks, and cement trucks would generate noise that would impact on-site workers and nearby residents, especially residents living immediately east and west of Zone 6. Construction equipment typically emits noise in the 86- to 94-dB range. Construction workers would use hearing protection and would follow OSHA standards and procedures. Direct exposure of NREL staff to construction noise would be generally limited to times when personnel were outdoors walking to or from parked vehicles or between buildings.

Construction near the east or west boundary of Zone 6 would occur close to residences, and noise could be a nuisance for some residents during the duration of construction. Construction-related noise impacts would vary with the phase of construction and would occur intermittently. Because this noise would be short-term and would comply with all applicable noise ordinances, it would not result in a significant adverse impact.

Operations

The proposed RSF is primarily an office building rather than a research and development or manufacturing facility. Consequently, long-term operational noise from the proposed RSF that would be discernible outside would generally be limited to noise from HVAC fans and similar equipment and would not adversely affect receptors. Operational noise from the TCUF upgrades would be very similar to operational noise from current TCUF operations. Because TCUF operations would be inside, there would be only a minor increment to the existing ambient noise in Zone 4. With the exception of the new parking lots in Zone 6, operation of the proposed site infrastructure improvements (roads, power, water, and telecommunications devices, etc.) would result in little, if any, additional ambient on-site noise. Operation of the parking lots in Zone 6 would result in elevated ambient noise twice each working day during rush-hour, when up to 600 to 800 vehicles would enter and leave the lots. Implementation of NREL's traffic mitigation plan would reduce the volume of cars during peak travel time thereby reducing overall noise during those times.

3.1.12 Public Services and Utilities

3.1.12.1 Existing Environment

The discussion of the existing public services and utilities environment (electricity and gas, telecommunications, water, sewage service, emergency response and fire protection) provided in the site-wide EA remains current.

3.1.12.2 Impacts of the Proposed Action

In the site-wide EA, DOE found that planned and contemplated expansions would not significantly affect the local and regional public service and utility infrastructure. In summary, the site-wide EA found the following:

- The increased demand for electricity and gas by the proposed facilities at the STM site is not expected to be substantial with respect to Xcel Energy's overall capacity or local infrastructure. The new demand would not contribute substantially to peak-period power demand and associated power generation capacities.
- The Proposed Action would improve and extend the on-site telecommunications infrastructure to support new research and development activities, facilities, and an increasing number of employees on the site. No off-site infrastructure requirements are needed, and the capacity of local service would not be adversely affected by the proposed improvements.
- The Proposed Action would incrementally increase the demand for domestic water and would require modifications and upgrades to the on-site domestic water infrastructure. The capacity of on-site infrastructure would be adequate with contemplated improvements. The current water system would accommodate additional buildings and associated office areas and restroom facilities with the addition of an underground pipe that would be installed from new buildings to the nearest domestic water loop. The long-term water system infrastructure and supplies are considered adequate to serve the site for the foreseeable future.
- The Proposed Action would increase demand on existing sewer infrastructure and treatment facilities associated with the Pleasant View Water and Sanitation District. The existing on-site system is considered adequate for current and anticipated future sewage needs. The capacity of the Metro Wastewater Reclamation District's downstream treatment plant in Denver is adequate to accommodate regional sewage needs for the foreseeable future.
- The new facilities and additional staff associated with the Proposed Action would incrementally increase demand for police, fire, and ambulance services, but the increases would be considered minor given site use, on-site security, and anticipated needs for emergency service providers. Moreover, NREL must contract for fire and ambulance services at the STM site and would pay for any increased level of service that is needed.

The impact of the Proposed Action that is the subject of this final SEA on the local and regional public service and utility infrastructure is bounded by the impacts discussed in the site-wide EA.

3.1.13 Environmental Justice

3.1.13.1 Existing Environment

Environmental justice is the fair treatment and meaningful involvement of all people regardless of race, color, national origin, or income with respect to the development, implementation, and enforcement of environmental laws, regulations, and policies. Fair treatment means that no group of people, including a racial, ethnic, or socioeconomic group, should bear a disproportionate share of the negative environmental consequences resulting from industrial, municipal, and commercial operations or the execution of Federal, state, local, and tribal programs and policies.

Executive Order 12898

Executive Order 12898, *Federal Actions to Address Environmental Justice in Minority Populations and Low-Income Populations* (59 FR 7629), directs federal agencies to identify and address, as appropriate, any activities that may affect minority and low-income populations. A minority has been defined as individual(s) who are members of the following population groups: American Indian or Alaska Native; Asian or Pacific Islander; Black, not of Hispanic origin; or Hispanic. A minority population has been identified where the minority population of the affected area exceeds 50 percent of the population. Low-income populations are groups with an annual income below the poverty threshold.

Demographic information obtained from the U.S. Census Bureau was used to identify low-income and minority populations near the site. Demographic maps were prepared using 2000 census data for these populations. Census data are compiled at a variety of levels corresponding to geographic areas. In order of decreasing size, the areas used are states, counties, census tracts, block groups, and blocks. A “block,” geographically the smallest census area, is usually bounded by visible features such as streets or streams or by invisible boundaries such as city limits, township lines, or property boundaries and offers the finest spatial resolution. Block data were used to characterize minority distribution. Figure 3-19, *Minority Population by Census Blocks*, shows census blocks near the site with minority populations ranging from less than 10 percent to more than 50 percent. The nearest census block with a minority population of more than 50 percent occurs about 400 meters (1,300 feet, or about one-quarter mile) south of the STM site. There are no census blocks with minority populations of more than 50 percent adjacent to the STM site.

Because block data are so specific to the individuals within a block (for example, sometimes only one family may live in a census block), income data are available only at the block group level and above. For this reason, block group data were used to identify low-income populations. The poverty level established by the Census Bureau for 2006 for a family of four is \$20,614. Figure 3-20, *Median Household Income by Census Block Groups*, shows average household income for the year 2000. Based on the Census Bureau’s criteria for low income, there are no census block groups of low-income households adjacent to or within a few miles of the STM site.

For the site-wide EA, Jefferson County noted that households earning less than 80 percent of the county's median household income of \$45,871 per year are considered “low-income” households and may qualify for affordable housing assistance within the county. In that EA, DOE identified Census Tract 101, within which the STM site lies, as qualifying as low-income under the Jefferson County criteria (Figure 3-21, *Median Household Income by Tracts Based on Jefferson County Standards*). An assessment at the more precise census block group geographic area (Figure 3-22, *Median Household Income by Census Block Groups Based on Jefferson County Standards*) clarifies that the census block group in which the STM site lies and its surrounding neighborhoods are not low-income by the Jefferson County criteria. However, the

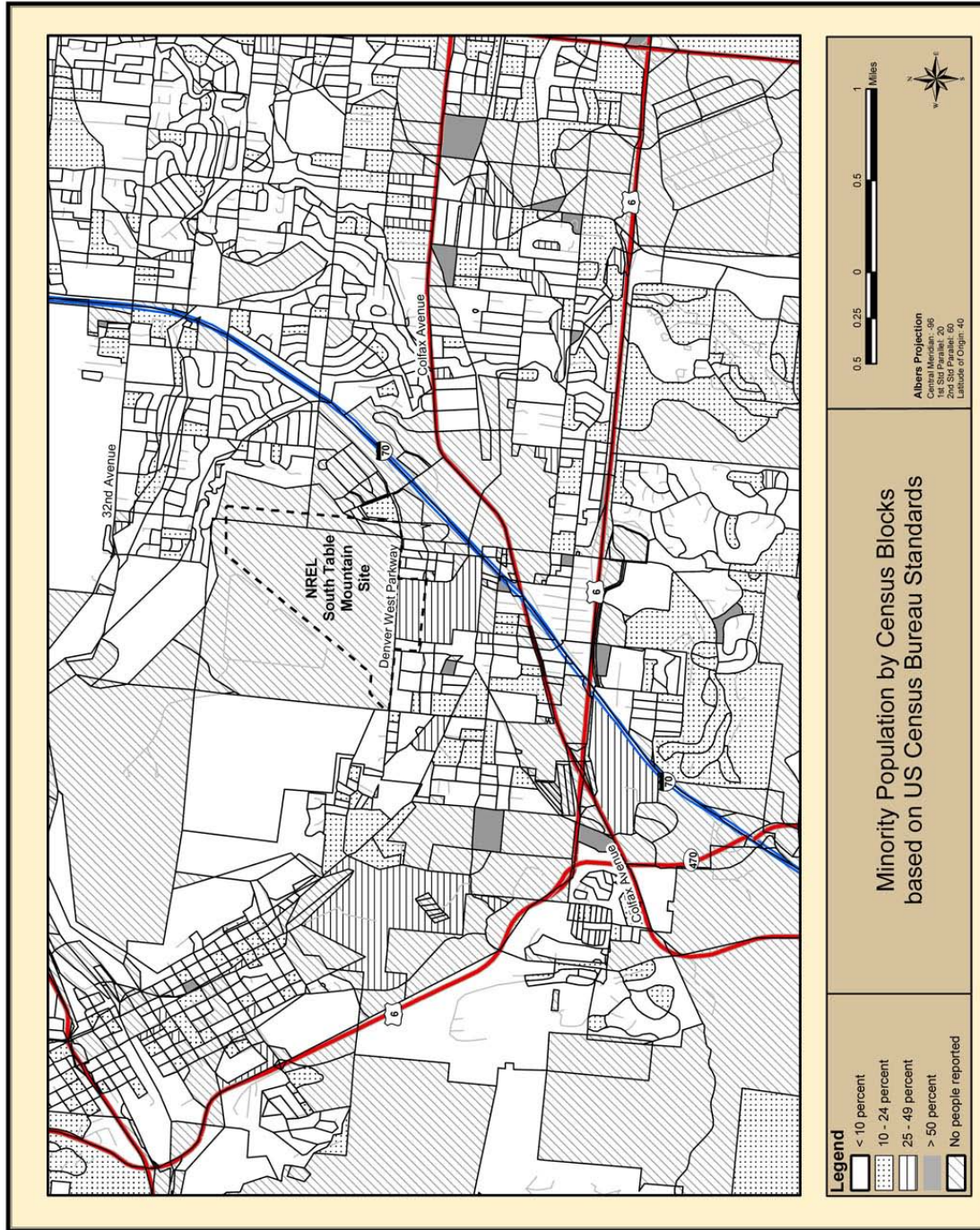
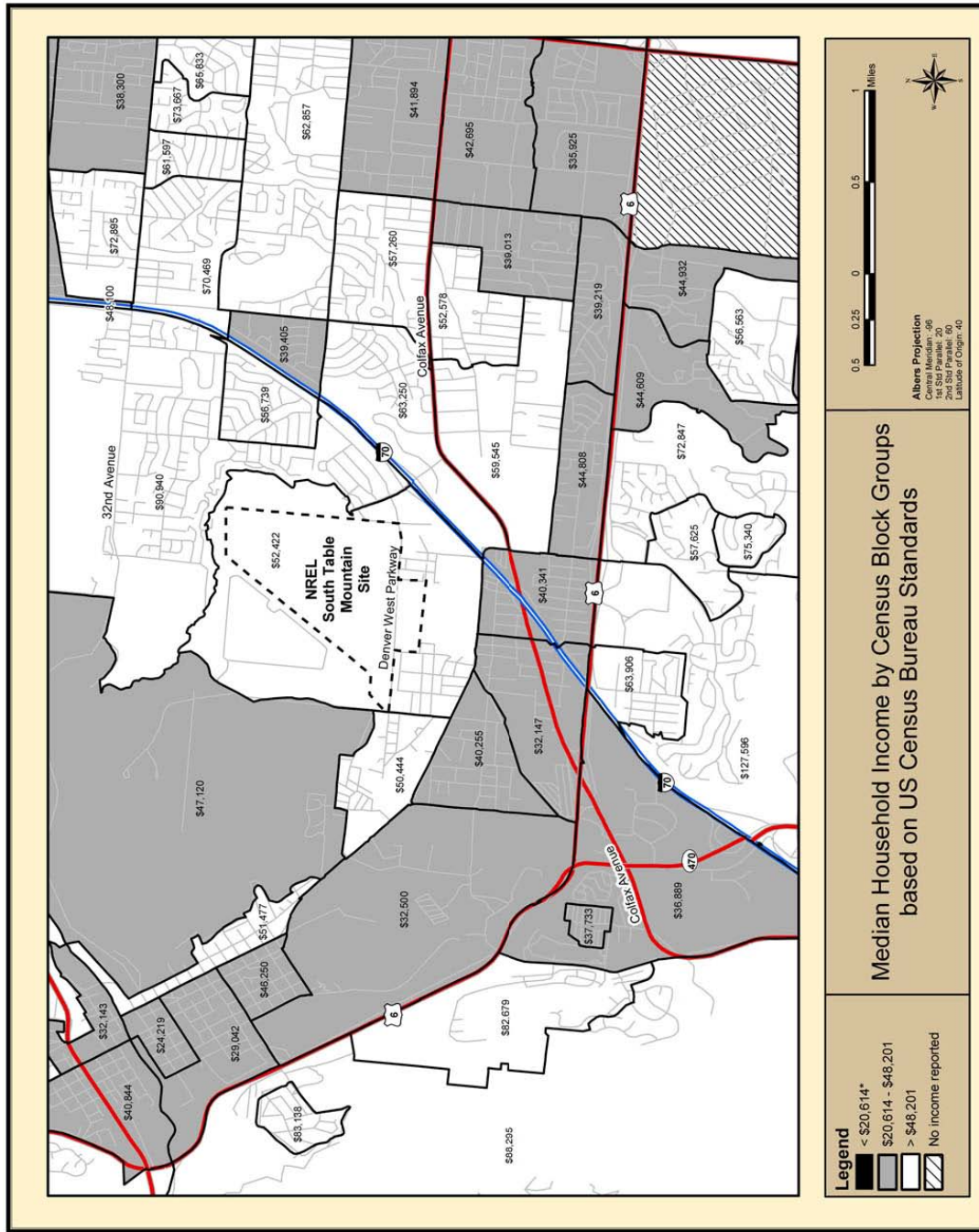

Figure 3-19. Minority Population by Census Blocks



* No low-income (<\$20,614) block groups located on the map.

Figure 3-20. Median Household Income by Census Block Groups

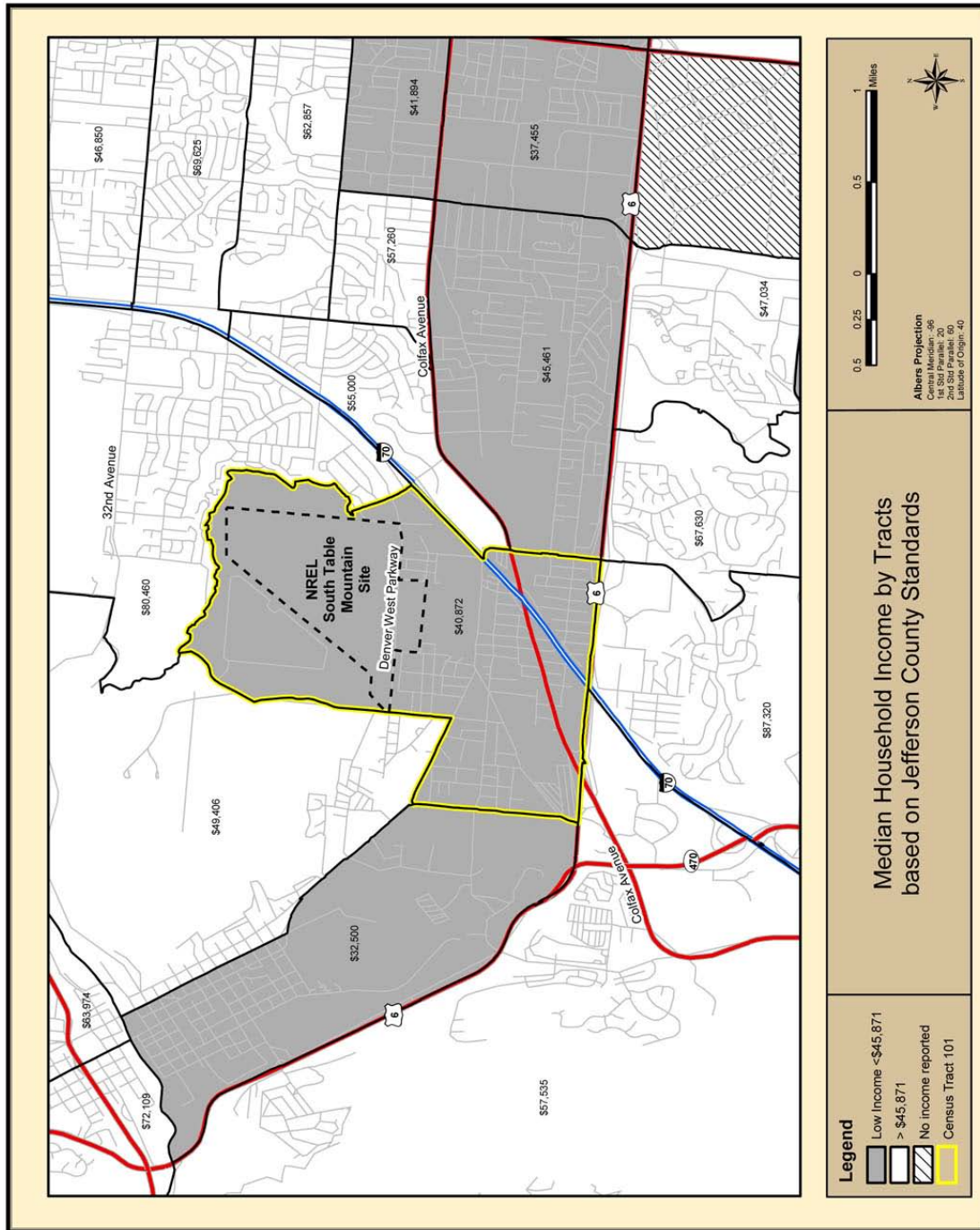

Figure 3-21. Median Household Income by Tracts Based on Jefferson County Standards

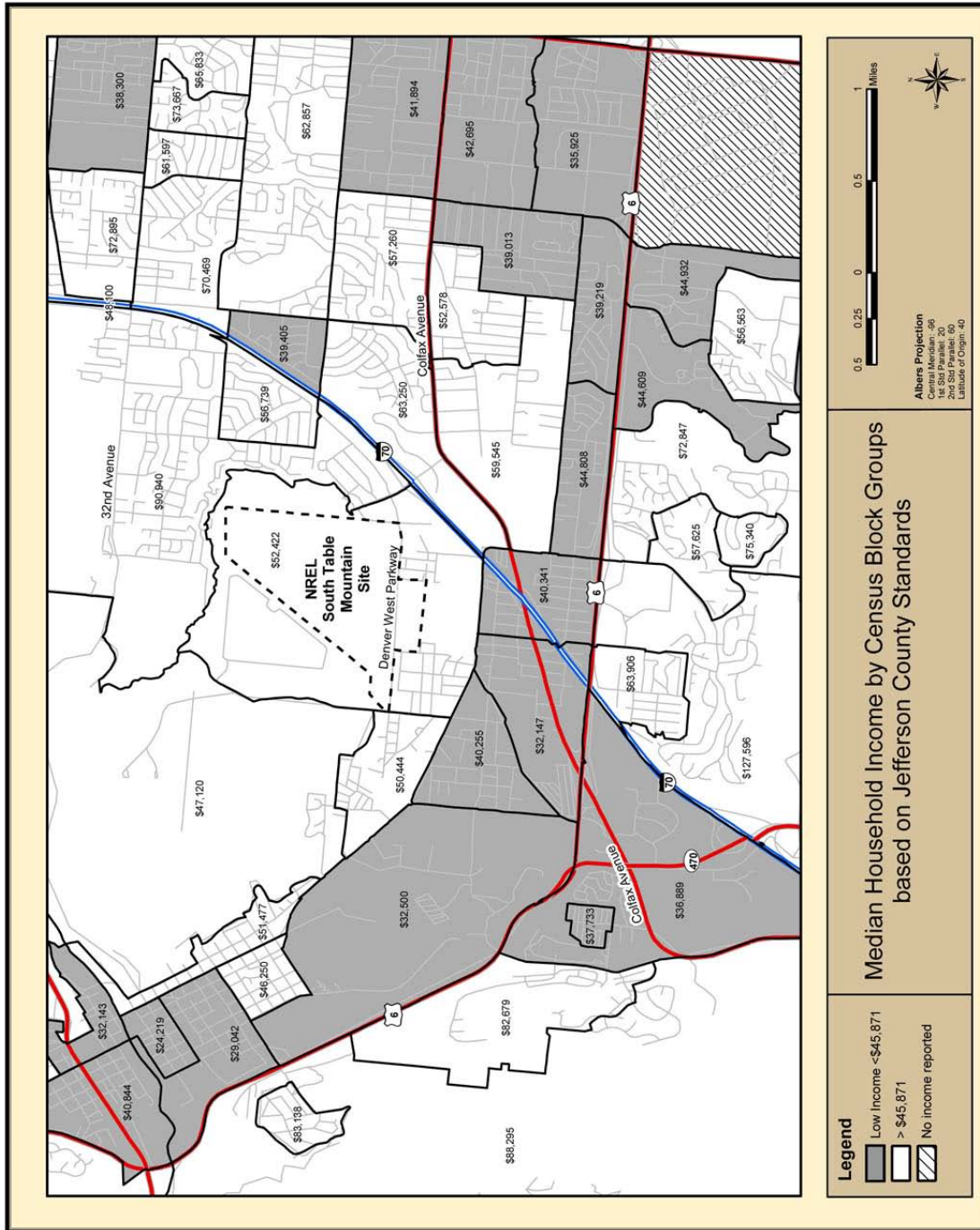

Figure 3-22. Median Household Income by Census Block Groups based on Jefferson County Standards

three census block groups that make up the remainder of Census Tract 101, which lie just south of Old Golden Road, qualify as low-income by the county's criteria.

3.1.13.2 Impacts of the Proposed Action

The Proposed Action would result in increased traffic entering and exiting the site. Under the Proposed Action, commuters who currently park at or near the DWOP would use local roads to gain access to the site (see Section 3.1.2, Traffic). However, as illustrated in Figures 3-19 through 3-22, this would not result in a disproportionate funneling or passage of traffic through low-income and/or minority neighborhoods. The increased traffic impact would be equally felt in all affected neighborhoods, whether they are low-income and minority areas or not. There would be no disproportionate adverse impact to low-income or minority neighborhoods.

3.1.14 Intentional Destructive Acts

The DOE Office of General Counsel has issued interim guidance stipulating that each DOE EIS and EA should explicitly consider intentional destructive acts (i.e., acts of sabotage or terrorism). DOE applied a sliding scale in considering the potential impacts of intentional destructive acts within the context of the Proposed Action.

None of the three proposed site improvement projects that are the subject of this final SEA would involve the transportation, storage, or use of radioactive or explosive materials. The existing TCUF and proposed TBPP involve the generation and storage of limited quantities of pyrolysis oil, which contains hazardous constituents, and flammable alcohols. Consequently, it is highly unlikely that the Proposed Action would be viewed as a potential target by saboteurs or terrorists. The Proposed Action would not offer any credible targets of opportunity for terrorists or saboteurs to inflict significant adverse impacts to human life, health, or safety, nor would the Proposed Action render the STM site as a whole any more susceptible to such acts. However, the consequences of an operational accident as defined in Section 3.1.3 could occur if initiated by an act of terrorism or sabotage.

3.1.15 Energy Efficiency and Sustainability

Sections 3.12 and 4.12 of the site-wide EA addressed energy efficiency, renewable energy, and sustainability at NREL. That EA emphasized that NREL takes energy conservation seriously and has implemented a comprehensive energy program as part of the "Sustainable NREL" initiative. NREL has a standing goal to reduce conventional energy use and views itself as a "model for the nation" in terms of sustainable technologies and designs. The proposed action addressed in the site-wide EA had a complex impact on energy efficiency and sustainability because it would increase on-site energy demand, generate small amounts of electricity for use on-site, and was expected to contribute substantially to nationwide and possibly global use of energy efficiency and renewable energy technology. However, overall, the proposed action addressed in the site-wide EA had a beneficial impact on energy efficiency and renewable energy. These conclusions bound the impact of the Proposed Action that is the subject of this final SEA.

The construction and operation of the proposed RSF; the installation of Phase 1 of planned site infrastructure improvements; and the upgrades to the TCUF and addition of the TBPP would increase on-site energy demand. However, each of these three elements also contributes directly or indirectly to national and possibly global energy efficiency and renewable energy technology development. The proposed TCUF upgrades and the TBPP are specifically intended to advance the development of renewable biomass fuel as a viable energy resource. The proposed RSF would feature and demonstrate a

cost-effective and energy-efficient office building design. It would include state-of-the-art demonstrations of the most recent building technology advances that would meet the U.S. Green Buildings Council LEED Platinum rating.

3.2 Environmental Consequences of the No Action Alternative

The No Action Alternative assumes that operations of the existing facilities at the STM site would continue, but that the three site development activities that make up the Proposed Action described in this final SEA would not occur. As such, the No Action Alternative is not tantamount to stating that no change or growth would occur at the site. Regardless of whether or not the Proposed Action is implemented, in the foreseeable future NREL would experience normal minor fluctuations, including growth, in staff levels, resource use, and environmental impacts due to currently authorized and planned programmatic growth and research activities that are not associated with the Proposed Action, but which would not cross the significance threshold under NEPA that would require separate evaluation under an EA or EIS. No major or significant new actions, as defined by CEQ (40CFR 1508.27), would be taken under the No Action Alternative.

The environmental consequences of the No Action Alternative would be very similar, and in some instances identical, to the Environmental Consequences of the No Action Alternative presented in the site-wide EA. These are summarized or updated below.

Under the No Action Alternative:

- Existing on-site land uses, site development density, and operations would continue to experience normal growth but would not be impacted or accelerated by the proposed RSF and associated site improvements. Fewer local beneficial economic impacts would result because construction would not occur, and related job growth and NREL development would be more limited.
- The incremental impacts to traffic and parking from site construction and changes to on-site and off-site traffic patterns due to staffing the RSF would be avoided.
- Emissions of criteria air pollutants and toxic air pollutants from the TBPP and TCUF upgrades and the RSF would not occur. In the short term, air emissions from site operations would remain at approximately current levels; in the longer term, increases in emissions would reflect normal site growth and development.
- The RSF and associated improvements would not add to the site's ambient noise level. Off-site noise levels in the area would continue to be dominated by vehicle traffic on I-70.
- There would be no increased runoff or impacts to surface water, stormwater, or groundwater resources due to the paving over of land for the proposed new parking lots and RSF.
- The loss of up to 7 hectares (17 acres) of grassland habitat due to paving and building construction would not occur.
- In the short term, the quantities and types of hazardous materials and hazardous wastes generated at the site would remain at approximately current levels; in the longer term, increases in waste generation would reflect normal site growth and development.
- Any incremental capacity impacts on existing service providers resulting from the Proposed Action and the impacts of associated infrastructure improvements would be avoided.
- In the short term, the site's energy consumption would remain at approximately current levels; in the longer term, increases in energy consumption would reflect normal growth and development.

4.0 CUMULATIVE AND SECONDARY IMPACTS

Cumulative impacts result from the incremental impact of a proposed action when added to other past, present, and reasonably foreseeable future actions. Secondary impacts are those that are caused by a proposed action, but may occur later in time or farther removed in distance, relative to the primary impacts of the proposed action (40 CFR Section 1508.7).

The 2003 site-wide EA considered cumulative and secondary impacts of various pending and conceptual site development projects and concluded that the incremental contribution to these cumulative and secondary impact areas would be insignificant. It also concluded that the No Action Alternative would not contribute to these impacts. The most important examples of cumulative and secondary impacts associated with the site-wide EA Proposed Action were as follows:

- traffic congestion at the intersections along Denver West Marriott Boulevard,
- regional and local air pollutant emissions,
- noise impacts on Pleasant View neighborhoods,
- development intensification,
- increases in Lena Gulch stormwater flows,
- habitat losses from development of natural areas,
- demand for energy, and
- beneficial impacts from improved alternative energy sources.

The Proposed Action that is the subject of this final supplemental environmental assessment (SEA) was not sufficiently far along in its conceptualization to be explicitly discussed in the site-wide EA. However, with the exception of visual impacts and safety, the preceding list of cumulative and secondary impacts bounds those that would be associated with this Proposed Action, which could result in cumulative and secondary impacts. In general, the impacts discussed below are considered cumulative and secondary impacts in light of DOE and NREL's planned future buildout at the STM site and the ongoing private development in the area. Figure 4-1 illustrates one conceptual site plan upon full buildout; however, the figure does not illustrate mesa-top facilities or those at the far western end of the site.

Traffic Congestion

As indicated in Figure 4-1, pending Congressional funding authorizations, DOE and NREL have long-term plans for additional buildings and staffing increases at the STM site. As indicated on Table 2-1, if the STM site were built out according to the Ten Year Site Plan (NREL 2006a), there could be as many as 2,675 employees at the STM site by 2019 resulting in 10,350 daily trips to and from the site. As described in Section 1.0, DOE evaluated buildout of the STM site in broad terms in a site-wide EA (DOE/EA-1440) (DOE 2003). At this time, future buildout scenarios beyond those assessed in this final SEA are still too speculative for detailed analysis and as such are not ready for decision-making; however, to understand the possible cumulative effects on traffic from future buildout, DOE evaluated projected future staffing levels in its traffic studies (FHU 2007) even though the proposed activities evaluated in this final SEA are independently justified without any future expansion. Traditional out-year traffic analyses are generated in 20-year increments; therefore, the reader will note that NREL's 2019 estimated built-out population has been extrapolated to 2030 in the traffic analyses summarized here.

Interpretation of multi-decade traffic projections must be tempered with the fact that such projections must make assumptions regarding hypothetical growth in the region; therefore, such projections may or may not be accurate. Such out-year projections are best used by planners (and DOE) as early flags to



Figure 4-1. Conceptual Schematic of Site after Full Buildout

possible problems that may arise. The projections also can be used to guide traffic impact mitigation planning and implementation and to support requests for funding to reduce or avoid unacceptable impacts. For perspective, in comparing Figure 4-2, the No Action Alternative in 2030, to Figure 3-5, the No Action Alternative in 2010, it can be noted that many intersections in the area may experience degradation in LOS to E or F, even without future expansion at the STM site by DOE.

When the projections of unmitigated traffic LOS at intersections in the area in 2030 for the No Action Alternative (Figure 4-2) are compared to the projections associated with the proposed long-term buildout of the STM site (Figure 4-3), projected degradation of LOS attributable to STM staffing increases can be seen at intersections 1, 3, and 4. No change in LOS is projected at intersection 2 in Figure 4-3 because the right-turn lane improvements committed to in this final SEA as part of the long-term traffic mitigation planning have been included in the modeling for Figure 4-3. The reader may also note, when comparing Figure 4-2 to Figure 4-3, improved LOS at intersections 8 and 9 under the proposed buildout. These improved LOS are the result of potential intersection improvements that are part of regional planning, but not actions proposed by DOE or NREL.

In addition to working with traffic planning agencies to support improvements to the area's traffic handling capacity to reduce foreseeable cumulative future problems, DOE is evaluating a suite of actions that would mitigate the projected long-term degradation of traffic LOS attributable to its proposed actions. In addition to the improvements discussed for the Denver West Parkway and Denver West Marriott Boulevard in this final SEA, DOE and NREL will continue to evaluate the application of the following mitigations:

- more intensive implementation of some degree of TDM measures;
- flow controls on exiting staff during peak arrival and departure hours to levels below the critical thresholds;
- a new STM site entrance that would provide direct access to South Golden Road; and
- off-site parking with bussing of staff to the STM site.

At this time, only the near-term staffing levels assessed in detail in this final SEA are realistic, as they are supported by Congressional funding actions. Future projections are highly speculative; therefore, DOE and NREL propose no specific mitigation actions at this time for future speculative cumulative impacts. However, as future site buildout plans develop over the coming years, DOE and NREL will work with regional traffic authorities and determine the suite of mitigations that will best fit foreseeable staff increases so that traffic impacts from DOE's and NREL's actions can be adequately mitigated.

Visual Impacts

Implementation of the Proposed Action would slightly modify the overall visual impression of the STM site by adding facilities on land that is planned for development but is not yet developed. Commercial development continues to occur adjacent to the STM site, further altering the visual landscape from open space to offices and residential buildings. Also, DOE anticipates further development (office or laboratories) in the northern half of Zone 6 between the proposed new parking lots and Denver West Parkway. This ongoing and planned DOE and commercial development, when added to the visual impacts described in Section 3, would constitute cumulative visual impacts, especially if construction occurred on Building Pad 1 in Zone 6.

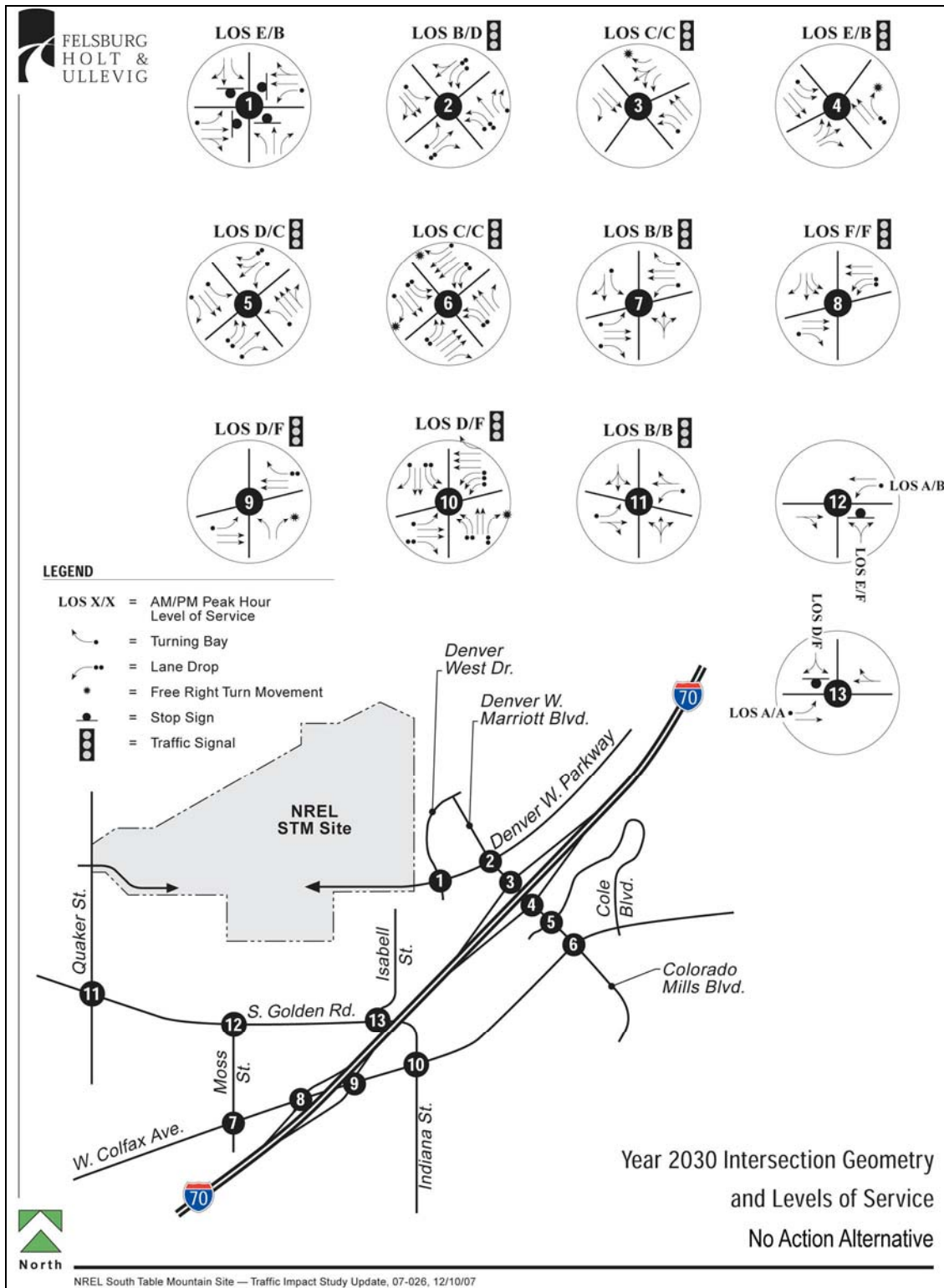

Source: FHU 2007

Figure 4-2. Year 2030 Intersection Geometry and LOS - No Action Alternative

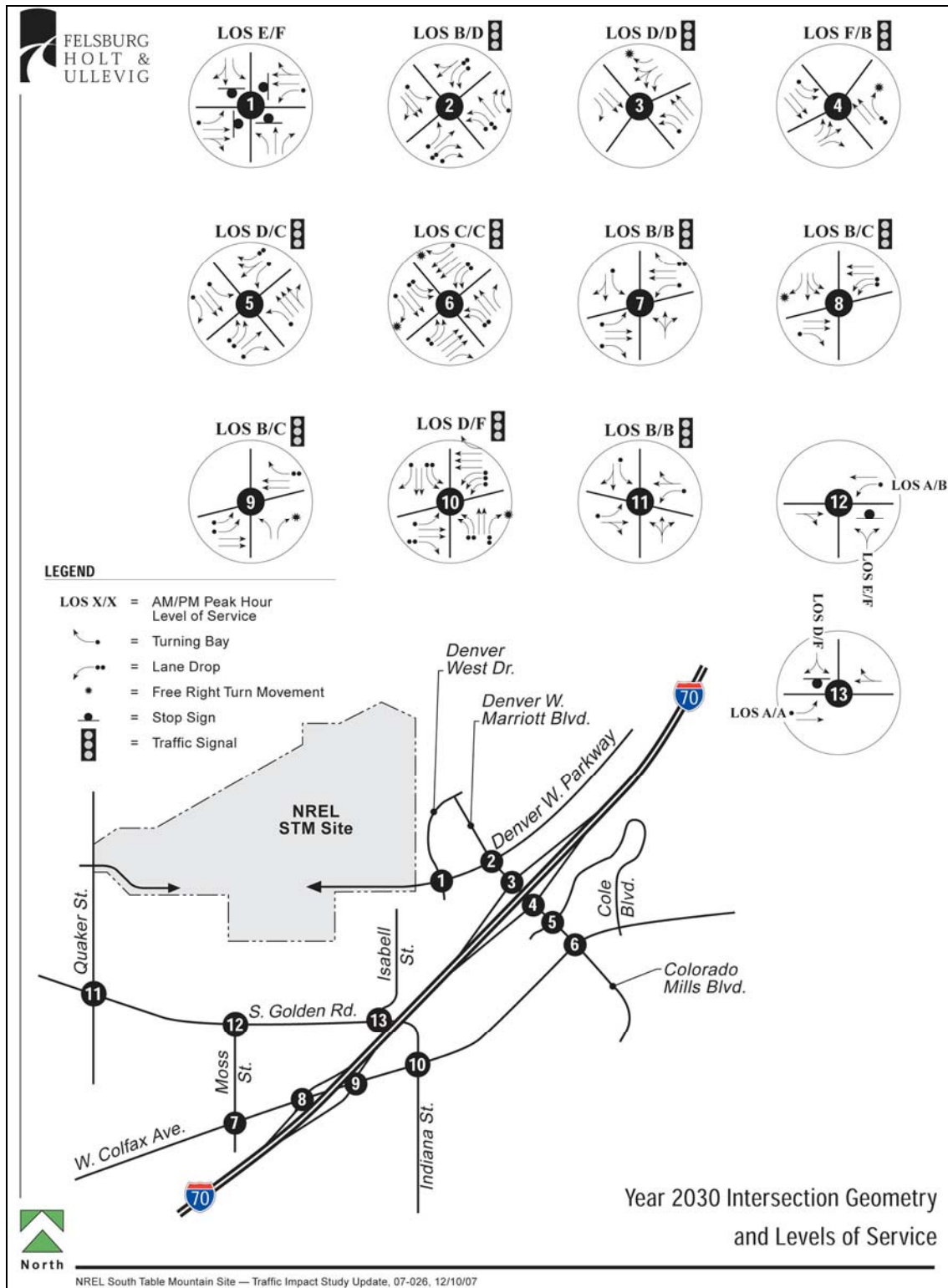

Source: FHU 2007

Figure 4-3. Year 2030 Intersection Geometry and LOS - Proposed Action

Increase in Lena Gulch Stormwater

Stormwater flooding in Lena Gulch is created by an off-site channel constriction in Camp George West Park. The Proposed Action would increase the impervious surface area on the STM site by up to 7 hectares (17 acres). Moreover, the planned further development of the STM site would further increase the impervious surface area. Similarly, projected and ongoing commercial development would further increase the impervious surface area and increase stormwater runoff flows into Lena Gulch. Collectively, the Proposed Action and future developments constitute a cumulative water quality and stormwater management impact. However, the new stormwater detention basins that are part of the Proposed Action would substantially mitigate the cumulative impacts of increases in Lena Gulch stormwater flows.

Demand for Energy

Implementation of the Proposed Action would increase the STM site's overall electric power use, the demand on regional power supplies, and the adequacy of the local power distribution infrastructure. The Proposed Action itself would not require upgrades to the existing power infrastructure. However, the Proposed Action, in combination with other planned future site developments and the projected continuing local development, would eventually require Xcel Energy, the regional power utility, to upgrade the local electrical infrastructure as noted in the following excerpt from an email received from Xcel Energy in May 2007.

The circuit this customer (NREL) is currently on has 16.3 megawatts of load and a normal rating of 18.7 megawatts. It will be good for the 2009 projected increase. After that we will need to do something. This would likely be switching some of this circuit's other load on to another circuit for 2010. Ultimately with this customer's added load and the projected added load from others in the area, a new circuit will be needed in the area. We already have additional substation capacity in the area to do this from. We have added this projected load increase into our forecasts and will continue to monitor the area's load requirements. At this point I (Xcel) do not foresee any additional costs to the customer for Xcel to serve this added load.

Habitat Loss

The Proposed Action would not have direct impacts on protected species or habitats. However, it would result in loss of wildlife habitat and could impact migratory bird species. The Proposed Action, combined with DOE's long-term buildout vision for the STM site, ultimately would entail complete or near-complete elimination of existing wildlife habitat in Zone 6 and most, if not all, of Zone 4. However, the cumulative impact of habitat loss due to on-site development would be mitigated by the preservation of 72 hectares (177 acres) of undisturbed on-site habitat in the conservation easement.

5.0 COMMITMENT OF RESOURCES AND SHORT-TERM USES

The discussions in Sections 5.1 and 5.2 were presented in the site-wide EA and are directly applicable to the Proposed Action that is the subject of this final SEA.

5.1 Irreversible/Irretrievable Commitment of Resources

An irreversible commitment of resources is defined as the loss of future options. The term applies primarily to the effects of use of nonrenewable resources such as minerals or cultural resources, or to those factors such as soil productivity that are renewable only over long periods. It could also apply to the loss of an experience as an indirect effect of a “permanent” change in the nature or character of the land. An irretrievable commitment of resources is defined as the loss of production, harvest, or use of natural resources. The amount of production forgone is irretrievable, but the action is not irreversible. If the use changes, it is possible to resume production.

The proposed developments in Zone 6 would result in the irreversible loss of an historical resource (Section 3.1.7.3). The Proposed Action would have no other irreversible impacts because future options for using the site would remain open. A future decommissioning process could restore the site for alternative uses, ranging from natural open space to urban development. No loss of future options would occur.

The primary irretrievable impacts of the Proposed Action would involve the use of energy, labor, materials, and funds, and the conversion of some lands from a natural condition through the construction of buildings and infrastructure. The direct losses of biological productivity and the use of natural resources from these impacts would be inconsequential.

5.2 The Relationship between Local Short-Term Uses of the Human Environment and the Maintenance and Enhancement of Long-Term Productivity

This section addresses the commitment of resources associated with the Proposed Action relative to the loss of long-term productivity associated with these commitments.

The Proposed Action would commit resources in the form of energy, labor, materials, funds, and land over 20 years or more. The justification for these commitments at this time is described in Section 1.3, Purpose and Need. Long-term productivity associated with the site relates to biological value as habitat and open-space values associated with aesthetic quality and recreation. The Proposed Action would be implemented at a site where substantial portions of the land are specifically reserved and preserved for these purposes. For these reasons, the incremental loss of biological and open-space values is balanced by the protections afforded to the long-term productivity of the site. Improved efficiency and increased use of renewable energy sources could substantially reduce the use of and reliance on imported fossil fuels.

6.0 REFERENCES

- AIHA (American Industrial Hygiene Association). 2004. *Emergency Response Planning Guidelines and Workplace Environmental Exposure Level Guidelines*. AIHA Press. Fairfax, VA.
- CDOW (Colorado Division of Wildlife). 2003. List of endangered, threatened and wildlife species of special concern.
- DOE (U.S. Department of Energy). 2007. *Final Environmental Assessment of Three Site Development Projects at the National Renewable Energy Laboratory South Table Mountain Site*. DOE/EA-1573. July.
- DOE (U.S. Department of Energy). 2003. *Final Site-Wide EA of the National Renewable Energy Laboratory's South Table Mountain Complex*. DOE/EA-1440. July.
- DRCOG (Denver Regional Council of Governments). 2005 *Metro Vision 2030 Plan*.
- EPA (U.S. Environmental Protection Agency). 2005. *Final NONROAD2005 Emissions Inventory Model (Nonroad engines, equipment, and vehicles)*. <http://www.epa.gov/otaq/nonrdmdl.htm>
- EPA (U.S. Environmental Protection Agency). 2004. *Exhaust and Crankcase Emission Factors for Nonroad Engine Modeling—Compression-Ignition*. NR-009c. EPA 420-P-04-009. Revised April 2004.
- FHU (Felsburg Holt & Ullevig). 2007. *National Renewable Energy Laboratory South Table Mountain Facility, Traffic Impact Study*.
- FHU (Felsburg Holt & Ullevig). 2006. *Interstate 70/32nd Avenue Interchange Environmental Assessment*. Prepared for the Colorado Department of Transportation, Federal Highway Administration, and City of Wheat Ridge.
- NREL (National Renewable Energy Laboratory). 2007a. *Project Report for the South Table Mountain Grand Buildout Infrastructure Plan*.
- NREL (National Renewable Energy Laboratory). 2007b. *Safe Operating Procedures for the Thermochemical Process Development Unit at FTLB High Bay*. FTLB/131-02. March.
- NREL (National Renewable Energy Laboratory). 2007c. *Thermochemical Ethanol via Indirect Gasification and Mixed Alcohol Synthesis of Lignocellulosic Biomass*, NREL/TP-510-41168, April.
- NREL (National Renewable Energy Laboratory). 2006a. *National Renewable Energy Laboratory Ten-Year Site Plan FY2007-FY2018*.
- NREL (National Renewable Energy Laboratory). 2006b. *Spill Prevention Control and Countermeasures (SPCC) Plan for the STM*. Procedure 6.2-10.
- NREL (National Renewable Energy Laboratory). 2005. *Wildlife Survey (Including Migratory Birds and Raptors) at the National Renewable Energy Laboratory South Table Mountain Site, Golden, Colorado*.

NREL (National Renewable Energy Laboratory). 2002. *Vegetation Survey, NREL South Table Mountain Site*.

NREL (National Renewable Energy Laboratory). 2001. *South Table Mountain Emissions Inventory*. July, updated for 2007.

NREL (National Renewable Energy Laboratory). 1999. *Site Conservation Easement Baseline Inventory*.

UrbanTrans. 2008. *Traffic Mitigation Plan*.

U.S. Fish and Wildlife Service (USFWS). 2004. Proposed, endangered, threatened, experimental, and candidate species and habitat list.

APPENDIX A SCOPING LETTER AND DISTRIBUTION LISTS

DOE mailed the scoping letter shown below to the businesses, agencies, and organizations shown in the mailing list that follows the letter. In addition, DOE mailed the scoping letter to all known Pleasant View residential addresses.

SCOPING LETTER



Department of Energy

Golden Field Office
1617 Cole Boulevard
Golden, Colorado 80401-3305

September 12, 2007

DISTRIBUTION LIST

SUBJECT: Request for Public and Agency Comments on the Proposed Research Support Facilities, Site Infrastructure Improvements (Phase 1 of Full Site Development), and Thermochemical User Facility Upgrade at The National Renewable Energy Laboratory's South Table Mountain Site

The U.S. Department of Energy (DOE), in compliance with the National Environmental Policy Act of 1969 (NEPA), will be preparing a Supplement to its Site-wide Environmental Assessment of the NREL South Table Mountain Complex (DOE/EA #1440, July 2003). The EA Supplement will analyze the proposed Research Support Facilities, Site Infrastructure Improvements (Phase 1 of Full Site Development), and Thermochemical User Facility Upgrade at the National Renewable Energy Laboratory's (NREL) South Table Mountain site near Golden, Colorado. A description of the site and the proposed site development projects is included in the attachment to this letter.

NREL is a federally owned, contractor-operated research facility that supports renewable energy and energy efficiency technologies. DOE is the lead agency for this EA Supplement, and other federal, state, and local agencies are invited to participate in the environmental assessment process. DOE is requesting public input on the proposed NEPA process, proposed actions and alternatives, and the environmental issues to be addressed in the EA.

Pursuant to the requirements of NEPA, the Council on Environmental Quality regulations for implementing the procedural provisions of NEPA (40 CFR Parts 1500-1508), and DOE's implementing procedures for compliance with NEPA (10 CFR Part 1021), DOE is preparing a draft EA Supplement to:

- Identify any adverse environmental effects that cannot be avoided should this proposed action be implemented.
- Evaluate viable alternatives to the proposed action, including a no action alternative.
- Describe the relationship between local short-term uses of the environment and the maintenance and enhancement of long-term productivity.
- Characterize any irreversible and irretrievable commitments of resources that would be involved should this proposed action be implemented.

Federal Recycling Program



Printed on Recycled Paper

2

DOE plans to complete the draft EA public review by January 2008. This letter and the draft EA, when it is available, will be posted in the DOE Golden Field Office electronic reading room: http://www.eere.energy.gov/golden/reading_room.aspx.

The DOE Golden Field Office welcomes your input throughout our NEPA process. Please direct your comments to:

Steve Blazek
NEPA Compliance Officer
DOE Golden Field Office
1617 Cole Boulevard
Golden, CO 80401-3393
(303) 275-4723
(303) 275- 4790 (fax)
Steve.Blazek@go.doe.gov

Please provide comments by October 12, 2007. We look forward to hearing from you.

Sincerely,



Gregory D. Collette
Office of Laboratory Operations
Acting Assistant Manager

Enclosure

cc: Maureen Jordan
Senior Environmental Scientist
NREL

MAILING LIST – ORGANIZATIONS

Lissa Kendall
Environmental Defense
Colorado Regional Office
2334 North Broadway
Boulder, CO 80304

National Wildlife Federation
2260 Baseline Road, Ste. 100
Boulder, CO 80302

Mr. David Abelson
Rocky Flats Stewardship Council
PO Box 17670
Boulder, CO 80304

Judy Denison
Save the Mesas
1027 9th St.
Golden, CO 80401

Ms. Susan LeFever, Director
Sierra Club
1536 Wynkoop St., Ste. B400
Denver, CO 80202

Table Mountains Conservation Fund
PO Box 16201
Golden, CO 80402-6004

VFW Post # 4171
15625 W. 10th Ave.
Golden, CO 80401

Ms. Penny Anderson
Energy Program Coordinator
Western Resource Advocates
2260 Baseline Road, Ste. 200
Boulder, CO 80302

Mr. TJ Brown
Front Range Field Director
Colorado Environmental Coalition
1536 Wynkoop, 5C
Denver, CO 80202

John Litz
Colorado Citizens for Planned
Growth and Open Space
11010 W. 29th Avenue
Lakewood, CO 80215-7120

Jeffco Open Space Foundation, Inc.
5855 Wadsworth Bypass
Building A, Ste. 100
Arvada, CO 80003

Mr. Steve Snyder
Assistant County Attorney
Jefferson County Open Space
100 Jefferson County Pkwy
Golden, CO 80419-5540

Final Supplement-1 to Final Site-Wide Environmental Assessment:
National Renewable Energy Laboratory South Table Mountain Site

MAILING LIST - AGENCIES

Mr. Brian St. George Bureau of
Land Management
2850 Younfield Street
Lakewood, CO 80215

Mr. James Martin Office of
Environmental Programs
4300 Cherry Creek Drive South
Denver, CO 80246

Mr. Gary Baughman, Div. Dir. Haz.
Materials & Waste Mgm't Div.
4300 Cherry Creek Drive South
Denver, CO 80246-1530

Mr. Paul Tourangeau, Div. Dir. Air
Pollution Control Division
4300 Cherry Creek Drive South
Denver, CO 80246-1530

Mr. Steve Gunderson, Div. Dir.
Water Quality Control Division
4300 Cherry Creek Drive South
Denver, CO 80246-1530

Mr. Vince Auriemma, Dep. Dir.
City of Golden Public Works
1445 10th Street
Golden, CO 80401

Mr. Steve Glueck, Director
City of Golden Planning &
Development
1455 10th Street
Golden, CO 80401

Ms. Becky Clark City of Lakewood
Planning Dept.
480 S. Allison Parkway
Civic Center North
Lakewood, CO 80226

Dr. Dana L. Winkelman, Director
Colo. Coop. Fish & Wildlife
201 JVK Wagar Building
CSU Campus Delivery 1484
Fort Collins, CO 80523-1484

Mr. Jim Miller Colorado
Department of Agriculture
Dir. Of Policy & Communication
700 Kipling Street, Ste. 4000
Lakewood, CO 80215

Mr. Jim Paulmeno, Planning & Env.
Mgr. Colo. Dept. of Transportation
Region 6 Office
2000 South Holly Street
Denver, CO 80222

Ms. Rebecca Vickers CDOT,
Environmental Services
Empire Park, Bldg. B
4201 E. Arkansas Ave.
Denver, CO 80222

Colorado Dept. of Natural
Resources
Executive Director's Office
1313 Sherman Street, Room 718
Denver, CO 80203

Mr. Gerald Craig, State Raptor
Biologist Colorado Division of
Wildlife
317 W. Prospect Road
Fort Collins, CO 80526

Mr. Perry Olson, Director Colorado
Division of Wildlife
6060 Broadway
Denver, CO 80216

Mr. Ralf Topper, Env. Specialist
Colorado Geological Survey
1313 Sherman Street, Rm 715
Denver, CO 80203

Mr. Tom Plant, Director Governor's
Energy Office
225 E. 16th Ave, Suite 650
Denver, CO 80203

Mr. Allen Gallamore Colorado State
Forest Service
Golden District Office
1504 Quaker Street
Golden, CO 80401-2956

Colorado State Land Board
1313 Sherman Street, Rm 621
Denver, CO 80203

Colorado State Patrol
Golden District, Troop Office, 6A
1096 McIntyre St.
Golden, CO 80401

Mr. Walter S. Welton, President
Consolidated Mutual Water Co
12700 W. 27th Ave.
Lakewood, CO 80215

Mr. Hal Simpson, State Engineer
Division of Water Resources
1313 Sherman St., Rm 818
Denver, CO 80203

Federal Aviation Administration
Northwest Mountain Office
1601 Lind Avenue SW
Renton, WA 98055-4056

Mr. Brad Bauer, Spec. Proj. Eng.
Div. of Hwys and Transportation
100 Jefferson County Pkwy
Golden, CO 80419-3500

Mr. Zeke Zebauers, Dir. Div. of
Highways and Transportation
100 Jefferson County Pkwy
Golden, CO 80419-3500

Mr. Jim Everson
Jefferson County Assessor
100 Jefferson County Parkway
Golden, CO 80419

Jefferson County Dept. of Health
Environmental Health Division
1801 19th St.
Golden, CO 80401

Mr. Tim McSherry Jefferson
County Emergency Management
800 Jefferson County Pkwy
Golden, CO 80419

Joy Lucisano, Mgr. Jefferson
County Open Space Acquisitions
700 Jefferson County Pkwy
Golden, CO 80419-5540

Mr. Ralph Schell, Director
Jefferson County Open Space
700 Jefferson County Pkwy
Golden, CO 80419

Final Supplement-1 to Final Site-Wide Environmental Assessment:
National Renewable Energy Laboratory South Table Mountain Site

MAILING LIST – AGENCIES (continued)

Mr. Steve Snyder Jefferson County Open Space Assistant County Attorney 100 Jefferson County Pkwy Golden, CO 80419-5540	Mr. Mike Schuster, Mgr. Jefferson County Planning & Zoning 100 Jefferson County Pkwy Golden, CO 80419-3500	Patrick O'Connell, Geologist Jefferson Co Planning & Zoning 100 Jefferson County Pkwy Golden, CO 80419-3550
Dr. Cindy Stevenson, Supt. Jefferson County Public Schools 1829 Denver West Drive Golden, CO 80401	Mr. Larry Benshoof, Director Jefferson County Road & Bridge 21401 Golden Gate Canyon Rd. Golden, CO 80403	Mr. Ted Mink, Sheriff Jefferson County Sheriff's Office 200 Jefferson County Pkwy Golden, CO 80401-2679
Theresa Pfeifer Metro Wastewater Reclamation Dist. 6450 York Street Denver, CO 80229-7499	Mr. Curtis Cesspooch, Chairman Northern Ute Indian Tribe PO Box 190 Ft. Duchesene, UT 84026	Office of Representative Ed Perlmutter 12600 W. Colfax Ave., #B400 Lakewood, CO 80215
Office of Representative Mark Udall 8601 Turnpike Drive #206 Westminster, CO 80031	Office of Senator Ken Salazar 2300 15th St., Ste. 450 Denver, CO 80202	Ms. Kristine Pollard Office of Senator Wayne Allard 7340 E. Caley, Suite 215 Englewood, CO 80111
Mr. Robert Pille, Director Oglala Sioux Tribe Environmental Protection PO Box 2008 Pine Ridge, SD 57770	Mr. Chris Malmgren, Chief Pleasant View Fire Department 955 Moss Street Golden, CO 80401	Stewart McCallister, District Coordinator Pleasant View Metro District 955 Moss Street Golden, CO 80401
Mr. David Councilman Pleasant View Water & Sanitation Dist. 955 Moss Street Golden, CO 80401	Ms. Andrea Taylor, Director Southern Ute Tribe Tribal Information Services PO Box 737 Ingacio, CO 81137	Mr. Clement Frost, Chairman Southern Ute Tribe PO Box 737 Ingacio, CO 81137
Mr. Neil Cloud Southern Ute Tribe NAGPRA Coordinator PO Box 737 Ingacio, CO 81137	State Historic Preservation Office 1300 Broadway-OAHP Denver, CO 80203	Governor Bill Ritter State of Colorado 136 State Capital Denver, CO 80203-1792
Susan Linner, Colorado Field Supervisor Fish & Wildlife Service PO Box 25486-DFC (65412) Denver, CO 80225	Mr. Edward Spence NRCS 655 Parfet Street, Room E-300 Lakewood, CO 80215-5517	Ms. Betsy Chappoose Uinta and Ouray Ute Indian Tribe Cultural Rights and Protection PO Box 190 Ft. Duchesene, UT 84026
Mr. Terry McKee Corps of Engineers, Omaha District 9307 S. Wadsworth Blvd. Littleton, CO 80128-6901	Mr. Gregory Davis US EPA - Region VIII Stormwater Coordinator; EPR-EP 1595 Wynkoop St. Denver, CO 80202-1129	Mr. Bert Garcia, Director US EPA - Region VIII Ecosystem Protection 1595 Wynkoop St. Denver, CO 80202-2405
Mr. Larry Svoboda US EPA - Region VIII NEPA Compliance, 8EPR-N 1595 Wynkoop St. Denver, CO 80202-1129	Mr. Manuel Heart, Chairman Ute Mountain Ute Tribal Council PO Box JJ Towaoc, CO 81334	West Metro Fire Protection District 447 S. Allison Parkway Lakewood, CO 80226-3128

Final Supplement-1 to Final Site-Wide Environmental Assessment:
National Renewable Energy Laboratory South Table Mountain Site

MAILING LIST - BUSINESSES

4-U Mini Mart
15750 S. Golden Rd.
Golden, CO 80401

7-Eleven Stores
16400 S. Golden Rd.
Golden, CO 80401

Absolute Tatoo
15750 S. Golden Rd.
Golden, CO 80401

AC Transmission
15435 W. Colfax Ave
Golden, CO 80401

Ace Liquor Store
16265 S. Golden Rd.
Golden, CO 80401

Advantage Appraisals Inc.
795 McIntyre St.
Golden, CO 80401

AMS
10433 Denver West Parkway
Golden, CO 80401

Anderson Services
1125 Quaker St.
Golden, CO 80401

Back Talk System
14998 W. 6th Ave., 500
Golden, CO 80401

Barnes & Noble
14371 W. Colfax Ave.
Golden, CO 80401

Bed Bath & Beyond
14275 W. Colfax Ave.
Golden, CO 80401

Bilg's Delicatessen
16400 S. Golden Rd.
Golden, CO 80401

Bobcat of the Rockies
15680 W. 6th Ave.
Golden, CO 80401

Boston Market, Inc.
14103 Denver West Parkway
Golden, CO 80401

Calvary Baptist Church
17050 S. Golden Rd.
Golden, CO 80401

Centennial Equipment Co.
15760 W. 6th Ave
Golden, CO 80401

Christy Sports
14371 W. Colfax Ave.
Golden, CO 80401

Classic Log Homes
15740 W 6th Ave.
Golden, CO 80401

CMC Challenge-Mfg-Consult
15744 W 6th Ave
Golden, CO 80401

Dept. 586 (Real Estate) Coleman
Cporation
PO Box 2931
Wichita, KS 67201

Colorado Business Bank
15710 W. Colfax Ave.
Golden, CO 80401

Colorado Concrete & Pottery
16601 S. Golden Rd.
Golden, CO 80401

Columbine Café
15630 S. Golden Rd.
Golden, CO 80401

Communication Industries, Ind
785 McIntyre St.
Golden, CO 80401

CSI Hobby Greenhouses
15850 W. Colfax Ave.
Golden, CO 80401

Custer & Steinmates
622 Gardenia Ct.
Golden, CO 80401

DAVCO Motors
795 McIntyre St.
Golden, CO 80401

Day's Inn Motel
15059 W. Colfax Ave.
Golden, CO 80401

DDRC Maintenance Terminal
16611 S. Golden Rd.
Golden, CO 80401

Denver Biomaterials Inc
14998 W. 6th Ave., 700
Golden, CO 80401

MAILING LIST – BUSINESSES (continued)

Mr. Greg Stevinson Denver West
Ltd.
1546 Cole Blvd
Golden, CO 80401

Ms. Valerie Farnham Denver West
Ltd.
1546 Cole Blvd
Golden, CO 80401

DOC
15000 W. 6th Ave., 102
Golden, CO 80401

Dolls Anonymous
16399 S. Golden Rd., Unit C
Golden, CO 80401

EAP Glass
616 Moss St.
Golden, CO 80401

Eggers Lapidary
16950 S. Golden Rd.
Golden, CO 80401

Einstein Bagel Company
14103 Denver West Parkway #100
Golden, CO 80401

Einstein Bros. Bagels
14401 W. Colfax Ave.
Golden, CO 80401

El Amigo Restaurant
16399 S. Golden Rd., Unit D
Golden, CO 80401

El Senor Sol
15900 W. Colfax Ave.
Golden, CO 80401

Energy West Controls
14828 W. 6th Ave.
Golden, CO 80401

Enstroms Candies
14415 W. Colfax Ave.
Golden, CO 80401

Enterprise Car Rental
885 Lupine St. A
Golden, CO 80401

Five R Repair
15590 W. Colfax Ave.
Golden, CO 80401

Foothills Chiropractic Health Center
16135 S. Golden Rd.
Golden, CO 80401

Foreign Car Service
16289 W. Colfax Ave.
Golden, CO 80401

Francis Veterinary
16199 S. Golden Rd.
Golden, CO 80401

Glasscraft, Inc.
626 Moss St.
Golden, CO 80401

Golden Auto Parts
16948 S. Golden Rd.
Golden, CO 80401

Golden Gate Parts
15990 S. Golden Rd.
Golden, CO 80401

Gram's Foods
15710 W. 6th Ave., 710
Golden, CO 80401

Holiday Inn West Village
14707 W. Colfax Ave.
Golden, CO 80401

Hops
14285 W. Colfax Ave.
Golden, CO 80401

Horizon Foods
16305 S. Golden Rd.
Golden, CO 80401

Intermountain Marketing
15000 W. 6th Ave., 200
Golden, CO 80401

J. F. Hurlbut Co.
622 Gardenia Ct.
Golden, CO 80401

Jamba Juice
14237 W. Colfax Ave.
Golden, CO 80401

JGS Contractors, Inc.
855 Lupine St.
Golden, CO 80401

K&P Inc.
777 Nile St.
Golden, CO 80401

K.E.M. Printing
16250 S. Golden Rd.
Golden, CO 80401

Final Supplement-1 to Final Site-Wide Environmental Assessment:
National Renewable Energy Laboratory South Table Mountain Site

MAILING LIST – BUSINESSES (continued)

Key Bank
14417 W. Colfax Ave.
Golden, CO 80401

Lawson Pain and Body
910 McIntyre St.
Golden, CO 80401

Le Peep
14401 W. Colfax Ave.
Golden, CO 80401

Leep'in Lizard SAAB
605 Lupine St.
Golden, CO 80401

Mac Vik Plumbing & Heating
16190 S. Golden Rd.
Golden, CO 80401

Macaroni Grill
14245 W. Colfax Ave.
Golden, CO 80401

Majestic Ventures
16500 S. Golden Rd.
Golden, CO 80401

Mannie and Bo's Pizzeria
16399 S. Golden Rd., Unit E
Golden, CO 80401

McKee Construction Co.
795 McIntyre St.
Golden, CO 80401

Method Machine Tools, Inc.
14998 W. 6th Ave.
Golden, CO 80401

Mier's Deli
15750 S. Golden Rd.
Golden, CO 80401

Mile Hi Chem Dry
15970 S. Golden Rd.
Golden, CO 80401

Mimi's Café
14265 W. Colfax Ave.
Golden, CO 80401

MLL General Contractors
665 Moss St.
Golden, CO 80401

Mobile Mechanic at the Shop
15810 W. Colfax Ave.
Golden, CO 80401

Mountain View Laundromat & Dry
Cleaner
15940 S Golden Rd.
Golden, CO 80401

Mountain View Motel
14825 W. Colfax Ave.
Golden, CO 80401

Mountain View Trailer Village
16100 S. Golden Rd.
Golden, CO 80401

Mr. Handyman
622 Gardenia Ct.
Golden, CO 80401

Nationwide Storage
16845 Mt. Vernon Rd.
Golden, CO 80401

Native Nursery - Tom Gillian
17025 S. Golden Rd.
Golden, CO 80401

Oasis Denver West Apt Homes
1910 Denver West Drive
Golden, CO 80401

Office Max
14275 W. Colfax Ave.
Golden, CO 80401

Old Golden Discount Liquors
15750 S. Golden Rd.
Golden, CO 80401

Old Navy
14367 W. Colfax Ave.
Golden, CO 80401

On the Border
14255 W. Colfax Ave.
Golden, CO 80401

Outback Steakhouse
14295 W. Colfax Ave.
Golden, CO 80401

Peregrine Communications Inc.
14818 W. 6th Ave., 15A
Golden, CO 80401

Perfection Tool Repair
16200 S. Golden Rd.
Golden, CO 80401

Performance Plus Auto Care
16099 S. Golden Rd.
Golden, CO 80401

MAILING LIST – BUSINESSES (continued)

Planet Honda
15601 W. Colfax Ave.
Golden, CO 80401

Pleasant View Beauty Salon
15940 S Golden Rd.
Golden, CO 80401

Pompoms & Whiskers Grooming
940 McIntyre St.
Golden, CO 80401

Quiznos
14413 W. Colfax Ave.
Golden, CO 80401

Reasonable Auto Service
15735 S. Golden Rd.
Golden, CO 80401

Regal Mortgage
795 McIntyre St.
Golden, CO 80401

Richards Agency
622 Gardenia Ct.
Golden, CO 80401

Rock Rest
16005 Mt. Vernon Rd.
Golden, CO 80401

Roofing Services, Inc.
15985 S. Golden Rd., Unit F
Golden, CO 80401

Rose Cleaners
14407 W. Colfax Ave.
Golden, CO 80401

Secor
14998 W. 6th Ave., Ste. 800
Golden, CO 80401

Sinclair Service Station
15495 W. Colfax Ave.
Golden, CO 80401

Sports Rack Vehicle Outfitter
15600 W. Colfax Ave.
Golden, CO 80401

Stevinson Chevrolet/Lexus
15000 W. Colfax Ave.
Golden, CO 80401

Stevinson Toyota
780 Indiana St.
Golden, CO 80401

Telecommunications Products, Inc.
795 McIntyre St.
Golden, CO 80401

Tokyo Joes
14227 W. Colfax Ave.
Golden, CO 80401

UA
14225 W. Colfax Ave.
Golden, CO 80401

U-Haul
15500 W. Colfax Ave.
Golden, CO 80401

Ultimate Electronics
14391 W. Colfax Ave.
Golden, CO 80401

Mr. Randy Christiansen United
Power
5 Grouse Dam Rd.
Golden, CO 80403

Wala Hair Studio
15750 S. Golden Rd.
Golden, CO 80401

Walts Tire Service
15990 S. Golden Rd.
Golden, CO 80401

West Side Auto Sales
676 Moss St.
Golden, CO 80401

Western Roofing
15810 W. 6th Ave
Golden, CO 80401

Mr. J. Yocom Yocom & McKee PC
15401 W. 9th Ave.
Golden, CO 80401

Mr. Carl Eiberger
14330 Fairview Lane
Golden, CO 80401

Mr. Craig Cox
2900 Vance Street
Denver, CO 80215

APPENDIX B SAFETY AND ACCIDENT ANALYSES

B.1 INTRODUCTION

This appendix addresses safety and accident issues associated with continued current operation of the Thermochemical User Facility (TCUF) (the No Action Alternative) and also those associated with the proposed additions and upgrades to the TCUF, the TCUF high bay area, and the proposed addition of the Thermochemical Biorefinery Pilot Plant (TBPP). Figure B-1 illustrates current TCUF operations.

The TCUF can operate in two modes: pyrolysis or gasification. Depending on the mode of operation, the TCUF operations can generate either pyrolysis oils or syngas (mainly carbon monoxide [CO] and hydrogen [H₂] with lesser amounts of carbon dioxide [CO₂] and methane).

In the pyrolysis mode, the system uses heat to convert biomass into liquid products. Pyrolysis is accomplished by transferring energy from a heat source into the biomass at a relatively high rate in the absence of free oxygen. Typical pyrolysis temperatures in the reactor are between 450 °C and 700 °C, and pressures range from slightly above atmospheric pressure to 8 pounds per square inch gauge (psig) (15 to 23 pounds per square inch absolute [psia]). A rupture disk connected to the vent system prevents the reactor from operating above 15 psig (30 psia). When pyrolysis oil is being produced, the gas exiting the cyclones and solid collectors is directly quenched by spraying it with dodecane in the scrubber section. Pyrolysis oil, sometimes called biocrude, is the primary product generated by pyrolysis. The oils consist of a wide range of chemical compounds with molecular weights between 16 and approximately 300. Typical pyrolysis yields based on a unit weight of biomass feed are as follows: oils – 45 to 65 percent; char – 10 to 20 percent; permanent gases – 20 to 30 percent; water – 10 to 25 percent.

In the gasification mode, higher temperatures (up to 900 °C) are used to “crack” the pyrolysis molecules to H₂, CO, CO₂, and methane, while steam-carbon reactions promote the formation of additional CO and H₂. Yields from gasification of biomass vary widely depending on feedstock, but generally give condensibles (oil and water) of around 1 percent, char from 10 to 20 percent, and permanent gases from 80 to 90 percent.

As the TCUF is currently configured and operated, there is more emphasis on producing products and less on the efficiency of operations. Thus, in the current configuration, there is no capability to capture the syngas or to regenerate the catalyst used in the reformer, and no effort has been made to heat feed streams using heat recovered from other parts of the process.

The proposed TBPP upgrade would modify the existing facility into an integrated process where the syngas can be purified and used to produce a limited quantity of a commercial product, ethanol, and a small quantity of heavier alcohols. One integration activity would continuously remove some of the catalyst used in the gasifier, regenerate it, and then return it to the gasifier, enabling continuous operation and the elimination of a waste stream. In the integrated TCUF/TBPP diagram shown in Figure B-2, the major new process operations, shown in red, would be located in a new annex building that would be built adjacent to the Field Test Laboratory Building (FTLB) in the area where an unused loading dock is located. In this accident appendix, two options for the TBPP equipment are considered. Option 1 would either modify existing space within the FTLB to safely accommodate TBPP or construct a self-contained building that would handle the new components of the pilot plant. Such a facility would be constructed to confine any releases or pressure vessel ruptures, thereby protecting non-involved workers or the more distant general population from the effects of such releases or failures. Option 2 would locate the TBPP equipment in the loading dock area but not enclose the equipment in a building.

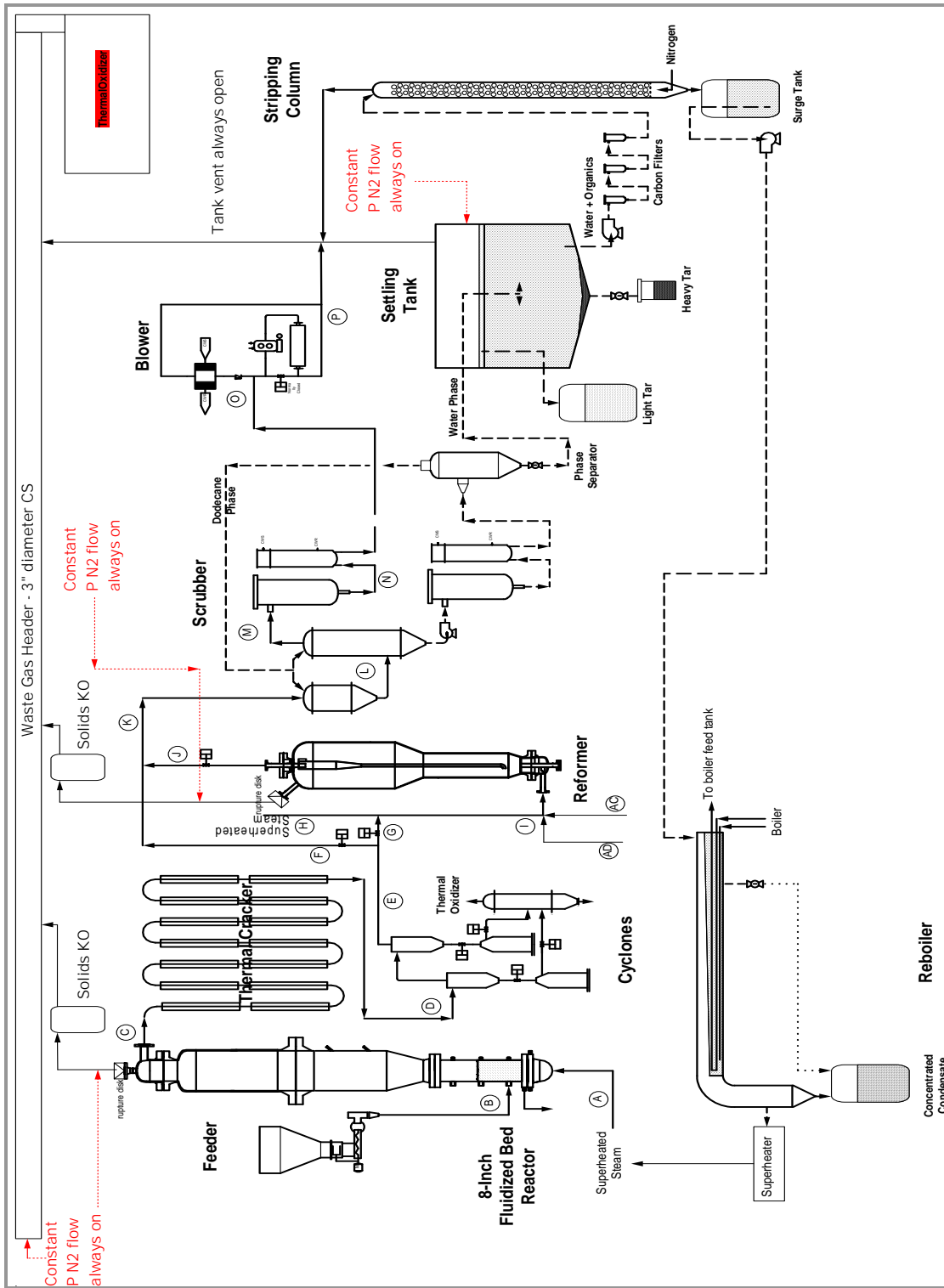

Figure B-1. Schematic of Current TCUF Processes and Flows

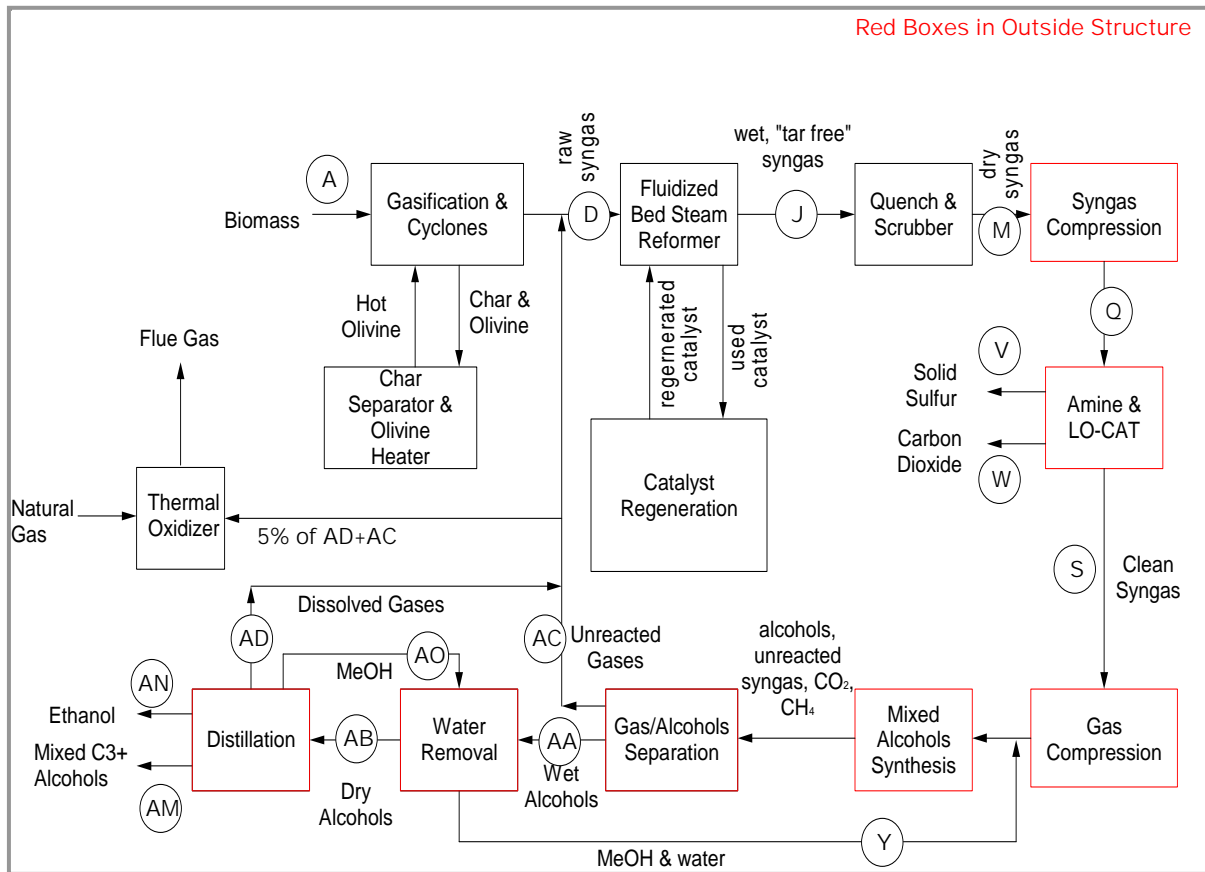

Figure B-2. Block Diagram of Integrated TCUF/TBPP

One of the goals of the proposed TBPP would be to demonstrate the capability of generating ethanol using as little external energy as possible. The unconverted gas from the synthesis reactor would be recovered and returned to the reformer where more syngas would be generated from the pyrolysis oil coming off the gasification column. While the amount of ethanol produced would increase significantly if all the unreacted syngas were recycled, 5 percent of it would be bled off into the thermal oxidizer and the heat generated would be used to dry the wood chips going into the gasifier column.

The following sections describe the current TCUF process in more detail and identify the hazards and the safety features installed to prevent or mitigate these hazards. This is followed by an identification of accident scenarios that are thought to be representative, and estimates of the likelihood and possible consequences should the accidents occur. Because there are no current hazards and operability studies (HAZOPs) or documented safety analyses (DSAs) for the facility, the evaluations might be more conservative than would have been reported if more documentation were available. There is a safe operating procedure (SOP) for the current facility that discusses many of its safety features. The SOP is used in the section discussing these safety features. Once completed for the current TCUF, the same accident analysis steps are repeated for the proposed TBPP.

B.2 SAFETY EVALUATION OF CURRENT TCUF OPERATIONS

B.2.1 Hazards of Current TCUF Operations

Many of the hazards associated with TCUF operations are standard industrial hazards. The non-standard hazards include operations at high temperature, use of combustible materials, and generation of hazardous products such as pyrolysis oil and syngas. Thus, good industrial safety practices and adherence to the guidelines in material safety data sheets (MSDSs) for handling hazardous materials are essential for worker safety. Pyrolysis oil is a mixture of more than 100 chemical compounds, many of which are carcinogenic and pose a risk from inhalation, ingestion, or dermal contact. H₂ gas has a wide flammability and explosive range, and CO is both flammable and toxic. Methanol poses a risk from ingestion, inhalation, and skin absorption. These hazards are well-documented, and well-understood procedures are used to protect workers from them. The hazards associated with handling these materials are exacerbated by the need to handle these materials safely in high-temperature operations.

B.2.2 TCUF Safety Features

The existing TCUF has been operated for several years, and safe operating procedures have been developed and implemented. Table B-1, taken from one of the operating procedures (NREL 1998), lists the facility's hazards and safety controls.

Table B-1 shows that hazards associated with operation of the TCUF are managed using a combination of engineered safety features and safe operating procedures. Taken together and if rigorously implemented these features and procedures minimize the risk to workers and the public from TCUF operations.

B.2.3 Postulated Accident Scenarios

During the design of the current TCUF, a preliminary HAZOP study was performed. The study documents each major process operation, including a comment section with many recommendations and questions. Table B-1 is organized by hazards and lists the safety features and safe operating practices that control the hazards. As such, the table contains many of the elements of a process hazards analysis. However, the first two columns in a typical process hazards assessment are missing. The first column would commonly list an initiating event, sometimes shown in the form a question, "What if ..." or a key word like "Too much ..." and a second column would describe the consequence of the process upset. In the absence of these two columns, a set of four process upsets (postulated accidents) associated with the current process was identified by means of reverse engineering. They are: (1) Spill or Rupture of a 114-Liter (30-Gallon) Drum of Pyrolysis Oil, (2) Release of Syngas to the Atmosphere, (3) Backflow of Dodecane into the Fluidized Bed Reactor, and (4) Failure of Inerting in the Off-gas System. More detailed modeling of the backflow accident may demonstrate that a backflow into the gasifier could not occur. However, in the absence of such a demonstration, it is considered a postulated and credible accident.

In this section, the four accident scenarios are described in detail, and an order-of-magnitude estimate is made of the "likelihood" that they could occur. Table B-2 identifies the terminology used to define the annual probability of occurrence and characterize the likelihood of occurrence of the accidents analyzed in this appendix. The accidents assessed in this SEA range from "Frequent", with an annual probability of occurrence of more than once in a year, or likely to occur many times during the life cycle of the system; to Extremely Remote, with an annual probability of occurrence between once in 10,000 and once in 1 million per year, or a probability of occurrence that cannot be distinguished from zero.

Table B-1. TCUF Hazards and Safety Controls

Hazard	Engineering Controls	Safe Work Practices	Personal Protective Equipment	Administrative Controls
High Temperature	<p>1) All hot surfaces are insulated or guarded with expanded metal cages. External temperatures not to exceed 140 °F.</p> <p>2) High-temperature override and alarms set at appropriate set points via the use of thermocouples on heated vessels.</p>	Proper PPE will be worn whenever entering the process area.	Leather gloves-are the minimum protection for hands. Hot-gloves when servicing hot, bare equipment. Non-melting clothing (such as cotton or Nomex) with long sleeves must be worn when working on hot, non-insulated equipment.	Process areas will be chained off and signs posted to prevent non-plant personnel from accessing hot areas.
Electrical Hazards	<p>1) All electrical installations are compliant with the NEC.</p> <p>2) The greatest voltage present is 480V between two terminals, and it is three-phase; 120V is the most widely used operating voltage.</p>	No work shall be performed on energized systems. LO/TO procedures shall be followed.	No additional PPE is required besides basic PPE required in all NREL laboratories.	Electrical Current and voltage measurements will be taken with standard test equipment to confirm that a “zero energy” state is reached.
Steam	<p>1) All hot surfaces are insulated. External temperatures are not to exceed 140 °F.</p> <p>2) A steam trap is used to drain condensate safely away from personnel.</p> <p>3) Pressure gauges are installed for checking line pressure.</p>	<p>1) Proper PPE will be worn whenever working in the process area.</p> <p>2) No work shall be performed on pressurized steam lines. See lock-out/tag-out (LO/TO) procedures.</p>	Leather gloves are all that apply. Long pants and safety glasses are standard equipment to work in the High bay	Operator will visually assure that nobody is around when manually blowing out the steam trap line, if required.

Table B-1. TCUF Hazards and Safety Controls (continued)

Hazard	Engineering Controls	Safe Work Practices	Personal Protective Equipment	Administrative Controls
Flammable & Combustible Liquids: - Acetone - Ethanol - Ethyl Acetate - Methanol - Pyrolysis Oil - Mixed Alcohols - Fischer-Tropsch liquids	1) These liquids will only be used in well-ventilated areas of the TCUF. 2) Transfer of liquids from TCUF will be pumped through plumbing system to designated drums or waste containers. 3) Open transfer of flammable liquids will be done in a certified Class I, Division 1 electrically rated room.	1) A static discharge-grounding strap shall be attached to the drum, metal transfer line, and the container. The grounding strap shall be inspected prior to each use to confirm that the attachment devices, connections, and conductor are in good condition. A continuity check of the strap should be done annually. 2) A watch person will observe the transfer from a safe distance. This person will have an appropriate fire extinguisher in hand (without pulling the pin) for use in case of an emergency. 3) No electrical contacts shall be made or disconnected during the transfer of these liquids. 4) No hot work, open flames, or other ignition sources are permitted during liquids transfer.	1) Flame resistant clothing (NOMEX) shall be worn during open transfers of quantities larger than one gallon. 2) A face shield and safety glasses or chemical splash goggles are required for the person making the transfer.	1) Only personnel involved in the transfer of liquids will be permitted within the ventilated area while transfer of liquids is occurring. 2) Signs will be posted warning all non-participating personnel to keep out of ventilated area during transfer. 3) Operators shall use the least flammable liquid suitable for a job, yet practical in terms of quantity required. 4) Collection drums shall be properly vented to either the thermal oxidizer or the ventilation system.

Table B-1. TCUF Hazards and Safety Controls (continued)

Hazard	Engineering Controls	Safe Work Practices	Personal Protective Equipment	Administrative Controls
<p>Flammable Gases:</p> <p>Syngas (varying amounts of CO, CO₂, methane, and H₂ gases.)</p>	<p>Inside process piping</p> <p>1) Feeding will be terminated if the internal process gas concentration reaches 10% of the minimum O₂ concentration and 25% of the lower flammable limit (LFL) for either H₂, CO, or CH₄. The LFL for H₂, CO, and CH₄ are 4.0%, 12.5%, and 5.0%, respectively. The minimum O₂ concentration for oxygen in hydrogen is 2%.</p> <p>2) The blower will be shut off if a pressure of 0 kPa gauge or lower occurs, preventing sub-ambient process pressures.</p> <p>External to process piping</p> <p>1) All flammable gases will be hard piped between sources and destinations.</p> <p>2) lower explosive limit (LEL) detectors, calibrated for H₂, are located at key locations in the TCUF to detect and warn of a combustible gas leak. A measurement of 10% of LEL will initiate a feeding system shutdown and process purging with nitrogen. A red warning light and audible alarm will activate at the 10% LEL level. An amber warning light will activate at 2.5% LEL.</p> <p>4) Pressure relief vents to thermal oxidizer.</p> <p>5) Local exhaust ventilation is used around equipment containing flammable gas compositions.</p> <p>6) Potential ignition sources have been removed from the scrubber/blower system enclosure.</p> <p>7) Using a H₂ standard in air, and following the manufacturer's procedure, the LEL detectors shall be calibrated quarterly or following a gas alarm.</p>	<p>Process piping will be leak checked before each cold startup to prevent leaks.</p> <p>1) A minimum quantity (1-week supply) of compressed flammable gases will be kept in the TCUF area. Additional flammable gas shall be kept at another location until needed.</p> <p>2) Oxy-acetylene gases shall be kept outside of the TCUF area.</p>	<p>1) Personnel shall not work in an environment within explosive limits.</p>	<p>1) No flammable gases shall be intentionally released to the open environment at any location within the TCUF.</p> <p>2) Flammable gases shall not be located closer than 20 feet from oxidizers.</p> <p>3) The LEL detector sensors shall be replaced at least every three years.</p> <p>4) If a high-high level of 10% of LEL is detected, the TCUF must be evacuated. Notify security of the situation. A portable LEL monitor shall be used when reentering the high bay after an evacuation alarm has occurred. A detector control panel is located inside the NE high bay doors. If all LEL monitors on the control panel indicate LEL levels are below 10% of LEL, reentry is allowed with a portable LEL detector to verify safe LEL levels exist. A LEL detector is available in the SERF cal lab.</p> <p>5) Feeding shall not resume until the source of combustible gas leak has been found and corrected.</p>

Table B-1. TCUF Hazards and Safety Controls (continued)

Hazard	Engineering Controls	Safe Work Practices	Personal Protective Equipment	Administrative Controls
Reproductive Toxicants (CO)	<p>1) Permanently installed CO monitors are located at key locations in the plant to detect and warn of high CO levels.</p> <p>2) Using a CO standard in air, and following the manufacturer's procedure, the CO detectors shall be calibrated quarterly or following a gas alarm.</p> <p>3) A CO level of 25 ppm will trigger an alarm on the operator computer screen and an amber warning light in the work area. A CO level of 200 ppm or higher will trigger a feeder shut down and activate a Red Warning Signal light and an audible alarm.</p>	<p>1) Compressed CO bottles shall be stored under ventilation adequate to prevent accumulation of CO beyond safe levels.</p> <p>2) Be aware of the following symptoms, and stop work immediately if they intensify:</p> <p>Lethargy Headache Nausea</p>	<p>No respirators are safe for CO environments. Only SCBA certified personnel may work in such a CO environment</p>	<p>1) Pregnant personnel shall be required to leave the high bay during the occurrence of a high-CO level (>25 ppm).</p> <p>2) If the CO level is at or below the OSHA TLV of 25 ppm, work may be done in order to remedy the problem (leak).</p> <p>3) Above 200-ppm level, operation will terminate, and the system will be purged; emergency exhaust fans will be activated. Notify site entrance personnel of the situation. Workers will evacuate the effected area until CO levels drop below 25 ppm.</p> <p>4) A portable CO monitor shall be used when reentering the high bay after an evacuation alarm. A detector control panel is located inside the NE high bay doors. If all CO monitors on the control panel indicate CO levels are below 25 ppm, reentry is allowed with a portable CO detector to verify safe CO levels exist. A CO detector is available in FTLB 137.</p> <p>5) Feeding shall not resume until the source of CO leak has been found and corrected.</p>

Table B-1. TCUF Hazards and Safety Controls (continued)

Hazard	Engineering Controls	Safe Work Practices	Personal Protective Equipment	Administrative Controls
Corrosive Liquids: hydrochloric acid potassium hydroxide sodium hydroxide sulfuric acid	1) Transfer of liquids from TCUF will be pumped through plumbing system to designated drums or waste containers. 2) Transfer of liquids to TCUF from drum or containers will be via pump installed on condensation train.	The NREL Chemical Safety Program shall be followed when using corrosive liquids.	1) A face shield <u>and</u> safety glasses or chemical splash goggles are required for the person making an open transfer. 2) A chemically resistant slicker suit, gloves and boots suitable for use with the liquids shall be worn during open transfer of corrosive liquids.	1) The use of corrosive liquids shall be minimized. 2) Exposure to corrosive liquids shall be minimized. 3) Personnel will be limited to the minimum number needed to do the job safely. (i.e. no unnecessary spectators).
Carcinogens	1) All piping is closed loop. There are no normal releases to the high bay atmosphere. 2) Any carcinogens escaping from the TCUF will be accompanied by CO, which is monitored continuously with audible alarms sounded if CO is present above 25 ppm.	The NREL Chemical Safety Program shall be followed when using carcinogens.	Chemical gloves shall be worn whenever a carcinogen is handled.	1) Carcinogens shall not be introduced into the TCUF at any stage of operation including startup, shutdown, or cleanup except when being used as a chemical feedstock. 2) Exposure to carcinogens shall be avoided.
Dust/Fibers	1) There are no piping discharges into the high bay environment; process piping terminates at the thermal oxidizer; the feed system vents are filtered and discharged to building exhaust ducts. 2) All fibrous insulation shall be installed in such a manner as to minimize the release of fibers into the air. 3) When practical, local ventilation snorkels shall be used for dust control.	All transfers of dust-generating materials such as catalysts shall be done within a ventilated area of the TCUF when possible and will be done in such a manner as to minimize the generation of airborne dust and fibers.	Dust masks shall be used at all times when handling dust- or fiber- generating materials (such as insulation), loading dusty biomass feed stocks, or when dust or fibers may become air born. Dust masks do not provide chemical protection and are only intended for nuisance dust levels.	All horizontal surfaces shall be periodically cleaned to remove accumulated dust. Exhaust ventilation ducts servicing the feed system shall be inspected annually for dust accumulation.

Table B-1. TCUF Hazards and Safety Controls (continued)

Hazard	Engineering Controls	Safe Work Practices	Personal Protective Equipment	Administrative Controls
High pressure gas cylinders	1) A designated area for gas bottles shall be provided with adequate facilities to secure all bottles without using the "double strapping" method. 2) No flexible lines shall be attached to the cylinder or its regulator unless it is (a) rated for the full bottle pressure, and (b) secured such that it cannot whip around in case of a rupture to the line.	1) Caps will be left on bottles until they are to be used and will be replaced when the use of the bottle is complete. 2) No tape, oil, or other foreign material shall be used on regulator threads for oxygen or oxidizing gases. 3) Only store with compatible gases. 4) Fire extinguishers, safety showers, and eyewash stations will be available.	Steel-toed shoes are recommended when moving gas cylinders.	1) Double strapping cylinders is prohibited. 2) Regulators shall be checked once per year for problems or each time it is changed, whichever is sooner. 3) Proper gas cylinder dolly shall be used at all times for the moving of cylinders.
Pressure	1) Pressure is controlled with regulators and automated control valves. Pressure is monitored with gauges and pressure transmitters. 2) Rupture disks are set to relieve at or below the MAWP of certified pressure vessels and at or below 15 psig for non-certified vessels.	Continuously check for any leaks or visually stressed components; although totally contained, there will be signs as a potential rupture develops.	No additional PPE is required besides basic PPE required in all NREL laboratories.	Periodically check rupture disks for integrity and replace if worn. Pressure relief valves must be checked every three years.

Table B-1. TCUF Hazards and Safety Controls (continued)

Hazard	Engineering Controls	Safe Work Practices	Personal Protective Equipment	Administrative Controls
Explosive/ Reactive Chemicals	<p>1) LEL detectors, calibrated for H₂, are permanently mounted in key locations in the TCUF. A measurement of 10% of LEL will initiate a feeding system shutdown and process purging with nitrogen. A red warning light and audible alarm will activate at the 10% LEL level. An amber warning light will activate at 2.5% LEL.</p> <p>2) Oxidizer sources are flow restricted to prevent excessive introduction of oxidizer in the event of a regulator or valve failure.</p> <p>3) Normally closed valves are used together with manual valves and a push-to-start button to prevent accidental introduction of oxidizer to process.</p> <p>4) There are nitrogen purges to flush the system and a loss of nitrogen alarm.</p> <p>5) Pressure relief vents to thermal oxidizer.</p> <p>6) Local exhaust ventilation is used around equipment containing flammable gas compositions.</p> <p>7) Potential ignition sources have been removed from the scrubber/blower system enclosure.</p> <p>8) Following the manufacturer's procedure, the LEL detectors shall be calibrated quarterly or following a gas alarm at 2.5% and 10% of LEL using H₂ in air as the calibration gas.</p>	<p>1) No introduction of any chemical shall be performed at any time except as directed by established operating procedures and according to an approved experimental operating plan using chemicals and feedstock approved in this SOP.</p> <p>2) No unauthorized experiments.</p>	<p>No additional PPE is required besides basic PPE required in all NREL laboratories.</p>	<p>1) Potentially explosive and highly reactive chemicals are not to be used in this process except when used under established process flow sheet conditions and within ranges set forth in the operating conditions.</p> <p>2) The LEL and UEL for H₂ in air is 4.0% to 76%, respectively. See Appendix J for Safety Data Sheet.</p> <p>3) On high-high alarms of the LEL, personnel shall vacate the high bay and call x-1234 to notify Security of the situation.</p> <p>4) A portable LEL monitor shall be used when reentering the high bay. A detector control panel is located inside the NE high bay doors. If all LEL monitors on the control panel indicate LEL levels are below 10% of LEL, reentry is allowed with a portable LEL detector to verify safe LEL levels exist. A LEL detector is available in the SERF calibration lab.</p> <p>5) Feeding shall not resume until the source of LEL leak has been found and corrected.</p>

Table B-1. TCUF Hazards and Safety Controls (continued)

Hazard	Engineering Controls	Safe Work Practices	Personal Protective Equipment	Administrative Controls
Mechanical machinery/equipment	1) Powered moving parts shall be guarded or shielded in such a manner that no body parts are capable of contacting the parts while in operation or while part is energized. Parts that move only with human power, such as turning a valve, do not require special guards.	1) No loose clothing, especially ties, shall be worn around moving equipment. 2) Reference <i>TCUF LO/TO Procedures</i> for work that requires the removal of guards.	Leather gloves may be worn to prevent hand cuts and abrasions as long as there is no reasonable chance that the gloves will become entangled in any moving equipment.	1) Work shall not be performed on energized, powered, or moving equipment with exposed moving parts. 2) A safe work permit from the ESH&Q office is required before operating or energizing equipment with exposed moving parts.
Noise	A baseline survey of all equipment shall be performed; sound mounts and covers shall be used on all equipment generating audible sounds over 80 dBA.	1) Workers should use hearing protection whenever noisy equipment is used. 2) If hearing protection is mandated, staff must complete an annual audiogram with medical.	1) Ear plugs and ear muffs are available. 2) A meter capable of measuring the noise amplitude is available in the high bay. The meter is used for qualitative measurement of general noise level. If a high noise level is noted, further measurement may be warranted to determine protection needs. All personnel and visitors entering the TCUF work area during operation shall wear hard hats. This area is clearly marked with hazard tape and signage.	1) Non-essential personnel shall be removed from areas of high noise exposure (90dBA) until the noise has been eliminated or its amplitude diminished. All others must use hearing protection. 2) If warranted, mandatory hearing protection areas will be identified and posted.
Falling objects	1) A solid floor has been installed on a majority of the high bay mezzanine structure. 2) Toe plates are installed on all edges of the mezzanine.	1) Warn personnel working below if falling objects are likely to occur. 2) If possible, mark off and chain off any area which poses a higher than normal risk of objects falling.		Visitors and non-operating personnel shall be kept to a minimum in the high bay.

Table B-1. TCUF Hazards and Safety Controls (continued)

Hazard	Engineering Controls	Safe Work Practices	Personal Protective Equipment	Administrative Controls
<p>Materials Handling:</p> <p>Hoisting Rigging Crane</p>	<p>1) A spring scale will be used when the potential load weight may be approaching maximum capacity.</p>	<p>1) Warn personnel working in area that loads will be suspended. 2) Mark off and chain off if possible, any area which poses a higher than normal risk of falling objects occurring. 3) Follow a periodic (once a month) internal inspection schedule.</p>	<p>1) A fall protection setup will be worn when the mezzanine gate is in the “up” position. 2) All personnel and visitors entering the TCUF work area during operation shall wear hard hats as well as steel-toed boots. This area is clearly marked with hazard tape and signage. Any hoisting/rigging done outside of this area must be specified with signage, and the PPE is the same.</p>	<p>1) Only qualified (trained) personnel shall operate the crane or any H&R equipment. 2) Annual certified inspections will be performed on the crane and all H&R equipment. 3) An inventory of all H&R equipment, along with all certification, shall be kept. 4) All rigging components shall exhibit all required identification.</p>
<p>TIG welding at FTLB-131 work bench</p>	<p>Room ventilation provides 6 air exchanges per hour. Smoke eater located at workbench captures fumes and smoke from welding. The TIG welder’s design is inherently good for minimal spark emissions.</p>	<p>No welding when alone without a special permit. Use welding curtains or shields to block others from inadvertently watching the welding arc.</p>	<p>Always use welding gloves and apron. Use a welding helmet with a number 12 eye protection filter shade.</p>	<p>Follow the same requirements listed for a hot work permit . Remove all combustible materials from the workbench area or cover with a welding blanket if removal is not possible. Use the staff welding shop whenever feasible.</p>

Table B-1. TCUF Hazards and Safety Controls (continued)

Hazard	Engineering Controls	Safe Work Practices	Personal Protective Equipment	Administrative Controls
<p>Grinding at stationary pedestal grinder in FTLB-131.</p>	<p>Safety guards are required equipment on the grinder and must not be removed.</p> <p>A work rest is available to support items being worked on. The rest must be adjusted regularly to maintain a gap no larger than 1/8-inch between the grinding wheel and the work rest.</p> <p>An electrical guard is installed for preventing re-start after power has been interrupted to the grinder.</p>	<p>Follow installation instructions each time a new wheel is mounted.</p> <p>Do not grind materials for which the wheel was not designed (e.g. soft metals such as aluminum or brass).</p> <p>Do not wear loose clothing or anything else that could get caught in the machine when operating the grinder. This includes ties, jewelry, long hair, or unbuttoned long sleeved shirts.</p> <p>Do not use a wheel with substantial nicks and scrapes or indications of cracks.</p> <p>Stand to the side of the grinding wheel when starting it.</p>	<p>Safety glasses with side shields.</p> <p>Hearing protection.</p> <p>Gloves.</p>	<p>Safety guards are used.</p> <p>The work area is maintained free of combustible materials that could be ignited by flying sparks generated during grinding.</p> <p>The machine-mounted light is to be used when grinding.</p> <p>Inspect the grinding wheel for damage before turning it on.</p> <p>Follow the same procedures as listed in the Hot work permit checklist to prevent spark-ignited fires.</p> <p>Use the smoke eater if grinding produces any appreciable smoke.</p>

Table B-2. Event Probability Classification Table

Level	Annual Probability	Likelihood
A	Frequent > 1.0	Likely to occur many times during the life cycle of the system (test/activity/operation)
B	Reasonably Probable 1.0 to 0.1	Likely to occur several times during the life cycle of the system
C	Occasional 0.01 to 0.1	Likely to occur sometime during the life cycle of the system
D	Remote 0.0001 to 0.01	Not likely to occur in the life cycle of the system, but possible
E	Extremely Remote 0.000001 to 0.0001	Probability of occurrence cannot be distinguished from zero
F	Not Reasonably Foreseeable < 0.000001	Probability of occurrence not reasonably foreseeable

Accidents less frequent than once in 1 million years are not reasonably foreseeable and therefore have not been considered in this SEA. Although formal calculations of the frequency of the accident scenarios were not made, as a rule of thumb a well-inspected and well-maintained engineered safety system would be expected to not perform its designed safety function about once in 100 to once in 10,000 actuations. A well-trained operator would be expected to not properly follow a procedure between once in 10 to once in 1,000 times. The exact frequency of mistakes is a function of the worker's environment and the complexity of the procedure.

Scenario 1. Spill or Rupture of a 114-Liter (30-Gallon) Drum of Pyrolysis Oil

This accident is postulated to occur during the handling of a drum of pyrolysis oil. It could occur within the facility or as a drum is being loaded onto a truck for shipment to another research facility. The drum is assumed to be filled to 109 liters (29 gallons) of its 114-liter (30-gallon) capacity, and the entire contents are assumed to spill and form a puddle. Two releases are considered. The first is the release of oil droplets into the air as the oil spills from the drum, and the second is oil evaporation from the pool. The pool is assumed to spread until it has a uniform depth of 1 centimeter (0.4 inch), resulting in a pool having a surface area of approximately 11 square meters (118 square feet). Because it could occur outdoors, the release is assumed to occur at ground level and not through the building exhaust system.

Improper handling of drums is often the most common cause of accidents in a facility handling hazardous materials. It is judged that loss of part of the contents of the drum as a result of a handling accident is between a "frequent" and "occasional" event, whereas loss of the entire contents of the drum is considered "remote".

Scenario 2. Release of Syngas to the Atmosphere

This accident is postulated to occur as a result of a failure in the thermal oxidizer in the vent system. While there are many engineering controls designed to warn the operator when the oxidizer is not operating, this accident is intended to bound any release of syngas from the system that could occur as a

result of a variety of failures, including operator error. To maximize the release of syngas, it is assumed that the TCUF is operating to produce syngas, the third mode of operation.

For this accident to occur, the thermal oxidizer must not be in operation. Because there are alarms and interlocks to warn the operating staff should the thermal oxidizer not be operating, the likelihood of this accident is judged to be “extremely remote”.

Scenario 3. Backflow of Dodecane into the Fluidized Bed Reactor

This is not an accident considered in developing Table B-1; however, backflow is a process upset normally considered in a HAZOP analysis. In the postulated accident, it is assumed that pressure builds up in the system, the rupture disk on the gasifier fails, and depressurization of the system induces backflow of dodecane into the gasifier, which then pressurizes and fails. A more detailed accident analysis may show that the amount of dodecane that would be sucked backwards during the depressurization can be handled by the vent system piping, which is standard 3.8-centimeter (1.5-inch) pipe.

For backflow of dodecane to occur, a series of failures must occur within a short period of time. Most if not all of the systems that have to fail for this incident to proceed are monitored by the operator and in some cases are alarmed. Thus, the likelihood of this accident is judged to be “extremely remote”.

Scenario 4. Failure of Inerting in the Off-gas System

Inerting is the presence or the introduction of a noncombustible, nonreactive gas (for example, nitrogen) in a system in high enough concentration to render the combustible material in the system incapable of supporting combustion. In this accident it is postulated that the vent system piping integrity is lost during operations and that air is sucked into the system. At the same time, a process upset that introduces hot syngas into the vent would have to occur. One event that could cause the introduction of the hot gas would be a failure of the rupture disk on the gasifier. This accident requires the simultaneous failure of two engineered systems and is therefore considered “extremely remote”. A more detailed accident analysis may also show that this accident requires too many engineered systems to fail and can therefore be considered to have a likelihood of occurrence of less than once in 1 million years and therefore does not need to be considered in any accident analysis.

B.2.4 Detailed (Bounding) Accident Analyses

Before analyzing the accidents, it is important to understand something about the risk of explosions when processing materials that are potentially explosive. Lees (Lees 1996) and Timmer and Lettner (Timmer and Lettner 2005) both suggest using the following equation to determine the lower flammability for mixtures of flammable gases. The following equation is suggested by both authors.

$$LFL_m = \frac{100}{\sum_{i=1}^n \frac{v_i}{LFL_i}}$$

where: v_i is the mole fraction of the i^{th} flammable species, calculated as a fraction of the flammable species, and LFL_i is the lower flammability limit for the i^{th} flammable species.

The *LFL* equation would normally be used for releases. In such releases the concentration of flammable materials builds up as the release continues. An analysis of many of the gas streams processed in the TCUF shows that almost all exceed the *LFL*. Thus, if the gas release is large enough, it is highly likely that the *LFL* would be exceeded.

Lees uses a form of the equation for *LFL* to estimate the *UFL* for flammable gas mixtures. Basically, in the above equation, *LFL* is replaced by *UFL*. Lettner states that the methane gas concentration is more a determinant of the change in the *UFL*. The equation recommended is:

$$UFL_m = \frac{100}{\frac{v_{CH_4}}{UFL_{CH_4}} + \frac{(1 - v_{CH_4})}{UFL_{MAX}}}$$

where: v_{CH_4} is the mole fraction of the methane and UFL_{MAX} is the upper flammability limit for the flammable species with the highest upper flammability limit.

The scenarios where the *UFL* would be most likely to control would be in leaks into equipment operating at below atmospheric pressure. Upsets at the front end of the process which result in subatmospheric pressure would most likely take place where the *UFL* would be used. Regarding the gas compositions in the pilot plant, it is a reasonable assumption that they would be between the *LFL* and the *UFL* with essentially no oxygen present.

The authors also point out that the flammability limits broaden with temperature. Lees provides some equations governing the broadening of the limits. They also list the maximum pressure from a deflagration of several of these compounds at one atmosphere and 25 °C. These are shown in Table B-3.

Table B-3. Maximum Deflagration Pressures for Flammable Compounds in Air

Component	P _{MAX} (psi)
Methane	120
H ₂	115
CO	119

The authors list the maximum pressures in bars, and these values have been converted to pounds per square inch in Table B-3. If ignition of these materials occurs in a vessel and the vessel is strong enough to contain the pressure pulse, then no energy is released. However, although the vessel itself would not fail, the piping attached to the vessel probably would fail. If the piping were large enough, the flame front would accelerate down the pipe and detonate about 13 pipe diameters from the vessel. The detonation pressure would fail the pipe, and the pipe would split longitudinally as the detonation front traveled down the pipe. The pressures in Table B-3 can also be exceeded if a liquid were to come into contact with very hot materials—for example, in a steam explosion. Higher pressures can also be realized if runaway chemical reactions were to occur. While most of the operations associated with the TCUF are

endothermic, there is one reaction, the Fischer-Tropsch synthesis reaction for producing higher molecular weight hydrocarbons from H₂ gas and CO, that is highly exothermic, and the reaction would accelerate very rapidly if cooling were lost.

The following analyses of the four accident scenarios described in the previous section are based on reasonable assumptions regarding the sequence of events that would have to occur for the event to happen. Safety analyses should be based on reasonable as opposed to bounding assumptions. Estimated impacts to the operating staff, to a non-involved worker 30 meters (98 feet) away, and to the nearest member of the public (112 meters away [367 feet]), are considered.

Analysis 1. Spill or Rupture of a 114-Liter (30-Gallon) Drum of Pyrolysis Oil

Pyrolysis oil is a complex mixture of chemicals. The most comprehensive listing of pyrolysis oil compounds and their hazards was developed by Diebold (Diebold 1997). Diebold lists 74 compounds which various authors have shown to have concentrations greater than 0.1 percent in pyrolysis oil.

For this analysis, concentration ranges for representative pyrolysis oil compound classes were examined. The mean of the ranges were totaled and then normalized to 100. Because the chemical properties and the Emergency Response Planning Guidelines-2 (ERPG-2) or Temporary Emergency Exposure Limits-2 (TEEL-2) values were not available for all the chemicals, a representative chemical in each class of chemicals (e.g., aldehydes) was selected and examined to see if the ERPG-2 or TEEL-2 values were available. If they were available and the chemical and physical properties were in the Areal Locations of Hazardous Atmospheres (ALOHA) program, then the plume concentration from a spill of that chemical was evaluated. In two cases, the representative chemicals were not in ALOHA, but sufficient information could be collected from their MSDSs and the library to enter the information needed for ALOHA to estimate the evaporation rate from the pool and also the concentration downwind from the spill. Because risk assessments should deal with expected conditions as opposed to bounding conditions, this is the proper approach.

In this analysis, two release fractions were considered, the first for the spill and the second for the evaporation from the pool formed as a result of the spill. The release fraction for the spill, basically droplets formed when the liquid strikes the floor, was estimated in an American National Standards Institute standard (ANSI 1998) to be 0.0002. The second release fraction is that associated with an evaporating pool. It was assumed that the pool would spread on the floor until it was about 1 centimeter (0.4 inch) deep, which means that the spill from a 114-liter (30-gallon) drum would measure about 11 square meters (118 square feet). This assumes that the 114-liter (30-gallon) drum was filled with 109 liters (29 gallons) of the oil and that all the oil spilled. Because the spill could occur while loading the drum onto a truck, the release height was assumed to be ground level. The plume dispersal model ALOHA (NOAA 2004) was used to estimate the evaporation rate from the pool and also the downwind concentration at 112 meters (367 feet), which is the location of the closest resident, and at 30 meters (98 feet), which is the location of the closest non-involved worker. The ALOHA code was run three times: once to estimate the pool evaporation rate, the second time to estimate the plume concentration at 112 meters from the combined release from the spill and evaporation, and the third time to estimate the concentration at 30 meters.

The atmospheric conditions were assumed to be: wind speed - 1.7 meters (5.6 feet) per second at 2 meters (6.5 feet); temperature - 29 °C; cloud cover - 10 percent; relative humidity - 50 percent; terrain roughness - urban; and inversion height - 300 meters (984 feet). Furthermore, the release was assumed to occur on June 30 at midnight. Under these assumed conditions, the plume would be dispersed under very stable atmospheric conditions - E stability.

A summary of the spill accident consequences is shown in Table B-4. For several representative compounds, release consequence data are not shown in Table B-4. In general, the most common reason for these omissions is that MSDSs could not be found for them, probably because no chemical company handles them as pure materials. However, the compounds for which data are missing represent only a small component in the mix of chemicals that comprises pyrolysis oil.

It is known that almost all of the compounds that have been identified in pyrolysis oil are highly polar molecules. Because the vapor pressure of highly polar molecules is generally low, the vapor pressure above a pyrolysis oil spill would not behave according to Raoult's law, which states that the partial pressure of a compound is equal to the vapor pressure of the compound times its molar concentration. However, in the absence of other information, assuming that Raoult's law would apply is the best assumption that can be made. It will certainly provide conservative results because the actual vapor pressure above the spill would be less than that predicted by Raoult's law. In the case of formaldehyde, enough is known to make corrections to the results predicted by Raoult's law. Specifically, it is known that although pure formaldehyde boils at $-19\text{ }^{\circ}\text{C}$, a solution of 37 percent formaldehyde stabilized with methyl alcohol boils at $101\text{ }^{\circ}\text{C}$, a difference of 120°C . To estimate the behavior of formaldehyde following a spill, the vapor pressure at $20\text{ }^{\circ}\text{C}$, which was given as 68 mmHg, was used to model the release. While similar corrections from Raoult's law might be warranted for other compounds in the pyrolysis oil, in the absence of any other information, no corrections were made.

Of the chemical compounds that were analyzed, formic acid concentration would exceed the ERPG-2 exposure limit by a factor of 2.5 at 30 meters (98 feet), the assumed location of the non-involved worker, and would be at 19 percent of the limit at 112 meters (367 feet), the distance to the nearest member of the public. The concentration of acetaldehyde would also exceed the ERPG-2 limit by a factor of 1.3 at 30 meters (98 feet) from the release point, but the concentration at 112 meters (367 feet) would only be 15 percent of the ERPG-2 limit. The ERPG-2 limit at 112 meters (367 feet) would not be exceeded for any single chemical, and the sum of the ratios of the concentration divided by the ERPG-2 limits would be only 0.365. Therefore, an off-site impact for the spill of a single 114-liter (30-gallon) drum of pyrolysis oil would not be anticipated. However, it is reasonable to develop on-site emergency response plans assuming that the ERPG-2 limit at 30 meters (98 feet) is exceeded for a 114-liter (30-gallon) spill of pyrolysis oil.

To exceed an ERPG limit, the concentration must be exceeded for 1 hour. Non-involved workers can be protected by sheltering in place and shutting down building ventilation systems. An effective emergency response effort on-site would ensure that the duration of exposure to non-involved workers would be much less than 1 hour. Thus, with effective emergency response measures, there should be no permanent health effects on-site from the spill of pyrolysis oil. DOE's Emergency Response Order, DOE O 151.1C, recommends the use of the DOT Emergency Response Guideline Book (The Orange Book) for planning the initial response to a spill. For materials such as acetaldehyde, the guidelines book would direct the emergency response actions to focus on individuals within 100 meters (330 feet) of the spill. The response suggested, using the TEEL values, is clearly a conservative response.

As stated previously, many conservative assumptions are built into this analysis. If and when more information is known about the vapor pressures of the individual compounds that make up pyrolysis oil, it will probably be possible to show that the estimates developed here are very conservative.

Table B-4. Release and Consequence Estimates for Spill of Pyrolysis Oil

Representative Compound	Est Wt %	gms/drum	Total Release gms/sec	Plume Conc at 112 meters	Plume Conc at 30 meters	ERPG-2 or TEEL-2	Fraction of ERPG-2 or TEEL-2 at 112 m	Fraction of ERG-2 or TEEL-2 at 30 m
Methanol	1.61	1403.92	0.19	0.497	6.52	1000	4.97E-04	6.52E-03
Ethanol	1.15	1002.80	0.10	0.182	2.39	3300	5.52E-05	7.24E-04
Ethylene Glycol	1.55	1351.60				40		
Acetone	3.21	2799.12	0.91	1.31	17.2	8500	1.54E-04	2.02E-03
2-Butanone (MEK)	0.69	601.68				2700		
2-Butenone*	2.06	1796.32						
Formaldehyde	2.00	1744.00	0.0253	0.071	0.928	10	7.1E-03	9.28E-02
Acetaldehyde	9.81	8554.32	7.5	30.7	268	200	1.54E-01	1.34E+00
Phenol	8.26	7202.72				23		
Formic Acid	16.23	14152.56	1.04	1.89	24.9	10	1.89E-01	2.49E+00
Methyl Formate	2.12	1848.64	1.20	1.67	22	500	3.34E-03	4.4E-02
2-methoxy phenol	9.92	8650.24						
2,6,DIOMe phenol	5.96	5197.12						
Fructose	10.78	9400.16	0.03					
Furfural Alcohol	7.22	6295.84	0.003	0.156	1.63	15	1.04E-02	1.09E-01
Hydroxyacetaldehyde	16.63	14501.36						
Dimethylcyclopentene	0.80	697.00						
Total	100.00	87200.00					3.65E-01	4.09E+00

Analysis 2. Release of Syngas to the Atmosphere

If the oxidizer does not operate when the TCUF is producing pyrolysis oil, the off-gases would discharge about 6 kilograms (kg) 14 pounds (lbs) of CO per hour, assuming the atmospheric conditions previously described. Based on an ALOHA calculation, the concentration downwind at 112 meters, the nearest off-site resident, would be 5.3 parts per million (ppm) if the release was at ground level and 0.9 ppm if the release was at 12 meters (39 feet), the approximate height if the release was from the stack. The concentration at 30 meters (98 feet), the assumed location of the nearest non-involved worker, would be 69 ppm for the ground-level release and zero for the elevated release. All these release concentrations are a small fraction of the ERPG-2 value of 350 ppm for CO. Thus, no long-term health effects to either the public or the non-involved worker are anticipated from this release. The facility operators could be exposed in the short term to excessive levels of CO. However, CO monitors are located throughout the facility, and since the operators are trained in effective emergency response measures from high levels of CO in the facility, no long-term health effects from the exposure are anticipated.

Analysis 3. Backflow of Dodecane into the Fluidized Bed Reactor

The initiator of this accident has to be an event that pressurizes the system and causes the rupture disk on the gasifier to fail. This could be initiated by a spill of dodecane followed by a fire. Dodecane is combustible as opposed to flammable, so even in the event of a spill it would not pose a major fire hazard at the temperatures at which the scrubber tanks are normally operated. The biggest hazard would occur if the dodecane not only spilled into the tank but also sprayed onto some of the hot equipment very close to the scrubber tanks. If this occurred, the dodecane could ignite, and the resultant pool fire could pressurize the tanks and the adjacent reactor vessels.

If the rupture disks failed, the pressure in the system would lower rapidly. If this occurred, and the cause was a dodecane fire, then the dodecane in the tank could flash to vapor and the two-phase flow would be directed backward into the hot reactor vessels, induced by the flow through the rupture disk into the vent system. If the liquid came into contact with the hot walls and sand in the reactor vessel, it would immediately flash, and it is unlikely that the vapor generated could be discharged through the 3.8-centimeter (1.5-inch) vent line. If the pressure buildup were sufficient, the vessel could explode similar to a steam explosion. The Brode equation is recommended for estimating the energy associated with a pressure vessel explosion (Lees 1996). The basis for the Brode equation is the following equation:

$$E = \frac{\Delta(pV)}{(\gamma - 1)}$$

where: the numerator is the change in the pressure volume product and the γ in the denominator is the ratio of the specific heats. In this case, because most of the gases present in the system are diatomic, it is reasonable to assume $\gamma = 1.4$. Inside the vessel, the volume is constant, so the equation becomes:

$$\Delta(pV) = (p_1 - p_0)V$$

Assuming that the vessel volume is 157.5 liters, which is half the free volume of the fluidized bed reactor vessel, and that vessel failure would occur at 400 psig, the explosion would be equivalent to 236 grams of trinitrotoluene (TNT). Such "TNT equivalent" weights are frequently adjusted by an efficiency factor because the change in pV is never converted to work with 100 percent efficiency. Applying a 40-percent efficiency factor, which is frequently used, results in the energy generated in the explosion being on the order of 100 grams of TNT. This would severely damage both the equipment and the facility, and since

the control room area is protected only by a sheet of Plexiglas, serious injury to the operators would occur. The building walls would contain any shrapnel generated from such an explosion, so no impacts to the non-involved worker or any member of the public is anticipated.

Many assumptions were made in this analysis, and the validity of some might be called into question. The leak would not only have to be sufficient to accumulate in the tray under the equipment, it would also have to hit some hot equipment. There would have to be enough dodecane in the tray under the tanks to cause a pool fire of long enough duration to bring it to the boiling point, and there must be enough restriction in the vent system to pressurize the entire system. All this would take some time, and the system might actually run out of dodecane before the pressure buildup were sufficient to fail the rupture disk. A more detailed analysis might show that this accident could not occur.

Analysis 4. Failure of Inerting in the Off-gas System

The inerting of the vent system is an important safety system because if the system were filled with H₂ and CO and the temperature reached the auto ignition point in the vent line, then the flame front would accelerate down the pipe. After about 13 pipe diameters, the flame front would have accelerated enough to initiate a detonation (Lees Sec 17.2.11). MSDSs give auto-ignition temperatures of 1,128 to 1,202 °F (609 – 650 °C) for CO, 999 °F (537 °C) for methane, and 932 °F (500 °C) for H₂ gas. The detonation shock wave, once formed, would continue down the pipe, rupturing it longitudinally as the shock wave traveled down the pipe. For the flame front to accelerate to the detonation velocity, the pipe must be big enough to allow the acceleration. A 3.8-centimeter (1.5-inch) pipe, the size of the pipe used in the TCUF vent system, is sufficient. This detonation would do extensive damage to equipment in the vicinity of the pipe. It is likely that a fire could ensue. While serious injury to the facility operators could occur, the building walls would contain any shrapnel generated from such an explosion, so no impacts to the non-involved worker or any member of the public is anticipated.

In a paper by Timmer and Lettner (2005), the potential for explosions in biomass gasification plants is analyzed, as are the explosion protection measures. These authors divide the prevention measures into three categories: primary, secondary, and tertiary. Two primary measures are avoiding explosive atmospheres inside and outside the pipes and avoiding leaks. Inerting the vent system avoids the presence of explosive atmospheres within the vent system. Two secondary measures are elimination of ignition sources and pressure relief. Tertiary measures include pressure resistant designs and protection of the operators. The current TCUF incorporates the primary and secondary features recommended by Timmer and Lettner. However, the current location of the control center does not provide a great deal of protection for the operators, one of the tertiary measures.

B.2.5 Summary of Accident Analyses for Current TCUF

From the many process upsets that could occur during the operation of the current TCUF, four accidents were selected to span the classes of accidents that could occur. These accidents were analyzed and the potential consequences determined. The accident that was estimated to have the highest likelihood of occurrence was the spill or rupture of a 114-liter (30-gallon) drum full of pyrolysis oil. The evaporation from the pool is estimated to result in concentrations of acetaldehyde and formic acid that would be above their ERPG-2 concentration limits at 30 meters (98 feet), the assumed location of the non-involved worker. The ERPG-2 limit would not be exceeded for any chemical at 112 meters (367 feet), the assumed location of the nearest member of the public, and using the sum of the ratios of the concentrations divided by the limits results in a sum that is much less than 1, which means that when all the chemicals released are considered, the limiting concentration would not be exceeded at 112 meters (367 feet). As stated above, for the ERPG-2 limit to be exceeded, the concentration must be exceeded for over 1 hour.

Sheltering in place, shutting down ventilation, and implementing effective emergency response measures should limit the exposure time to the non-involved worker to much less than 1 hour, so no permanent health effects would be anticipated. The remaining accidents that were analyzed were judged to be less likely to occur and the projected damage was more localized, albeit more severe. While serious injuries could occur to the operators from the accidents that result in an explosion, none showed impacts to non-involved workers or members of the public. Engineering controls and emergency operating procedures were found to be in place. Therefore, so long as the safety systems are maintained in a reliable state and workers were trained in, and would implement, emergency procedures, both the likelihood and the consequences of these accidents can be maintained at an acceptable level.

B.3 SAFETY ANALYSIS OF THE PROPOSED TBPP AND UPGRADES TO THE TCUF

The proposed TBPP and upgrades to the TCUF add processes which remove water, CO₂, and sulfur from the syngas before it is sent into a tube and shell catalytic reactor, where the syngas would be converted into ethanol and a small amount of higher molecular weight alcohols. Much of the current process would remain the same. Consequently, all the accidents evaluated for the current TCUF process would remain applicable if the proposed TCUF upgrades and the TBPP were implemented. To convert the syngas into ethanol using the Fischer-Tropsch process, the added process equipment must operate at high pressure (up to 1,000 psia), and intermediate temperatures (500 to 600 °F). In addition, the Fischer-Tropsch reaction is highly exothermic. Thus, if cooling were lost, the reaction would run away and damage the synthesis reactor. As described previously, this accident appendix considers two options for the TBPP equipment. Option 1 would either modify existing space within FTLB to safely accommodate the TBPP or construct a self-contained building that would handle the new components of the pilot plant. Such a facility would be constructed to confine any releases or pressure vessel ruptures, thereby protecting non-involved workers or the more distant general population from the effects of such releases or failures. Option 2 would locate the TBPP equipment in the loading dock area but not enclose the equipment in a building

B.3.1 Hazards Analysis

Of the activities being considered in this final SEA, the upgrades to the TCUF and the TBPP pose the greatest potential hazard. Many safety features incorporated into current TCUF operations also provide assurance that the proposed TCUF upgrades and the TBPP could be operated safely. Table B-5 lists some of the hazards for the TCUF and the protective features that have been (or, in the case of TBPP, would be) incorporated to protect both equipment and personnel.

Table B-5 shows that each potential deviation is protected against by a safeguard feature. In addition to the engineered safeguards, all operators of the TBPP would be trained in the proper response to various process upsets, as well as the proper normal operation of the facility. The staff is committed to continuing this level of safety, both engineering and procedural, for the proposed upgrade. Although a formal process hazards analysis has not been performed for this facility, the following sections consider two additional process upsets that, together with the four accident scenarios considered above, are believed to bound the types of accidents that could occur at both the existing TCUF and the proposed TBPP.

Table B-5. Potential Hazards and Installed Safeguards

Explosive Gas Concentrations	Combustible gas monitors are installed near where leaks might occur and also around the facility. If threshold concentrations were exceeded, the alarm is displayed in the control room, so the process could be shut down.
High Temperatures	Equipment that is operated at high temperature is tagged or otherwise guarded to prevent workers from accidentally coming in contact with hot surfaces.
Combustible Liquids	Combustible liquids are dodecane in the current system and methanol and ethanol in the planned expansion. The area under the dodecane tanks has a metal tray that is capable of holding the entire inventory of dodecane. The new annex would be constructed so that any spills of methanol or ethanol would collect in sumps from which the liquid could be safely removed.
Overpressurization	Should the pressure build up in the pyrolysis or gasification units, a rupture disk, set at 8 psig, would discharge the contents of the vessel into a nitrogen-inerted vent system. The vented material would pass through a thermal oxidizer, after which the gases would be water vapor and CO ₂ . If the rupture disk failed, the system would immediately shut down.
Autoignition of Flammable Gases	Several gases, particularly H ₂ and CO, are present in equipment above their auto-ignition temperatures. This area of the pilot plant operates at low pressure, which makes leaks less likely to occur. When the gases discharge into the vent system, ignition is prevented by inerting the system. Oxygen monitors confirm that the level is low enough to prevent a fire or explosion.
Autocatalytic Reaction	In the proposed TBPP, the reaction occurring in the synthesis reactor (the conversion of methanol, CO, and H ₂ into ethanol and some higher alcohols) is highly exothermic and would auto-catalyze and run away if cooling were lost. Thus, a loss of cooling water could potentially result in a vessel explosion. If the failure were ductile, few fragments would be produced. However, the presence of H ₂ and the thermal cycling could result in brittle failure and the production of many more fragments. The cooling tubes, instrument wells, and small components such as valves located in close proximity to the vessel could also become fragments from the vessel failure. Any fragments would be accelerated to significant velocities, perhaps as high as 100 meters (330 feet) per second. Under Option 1, TBPP operation would occur within the FTLB or in a building in the proposed annex; if necessary, the reactor vessel would also be encapsulated. The area would not be occupied when the synthesis reactor was operating, preventing worker injuries. Under Option 2, the reactor would not be housed in a building designed to confine such explosions; non-involved workers and perhaps the general public might be affected by fragments from an exploding vessel. Individuals close enough to the blast could have ruptured or otherwise damaged eardrums. Although extremely remote, the possibility of fatalities cannot be excluded.
Failure of the Thermal Oxidizer	The thermal oxidizer is basically a gas furnace into which natural gas and the gases in the vent, normally just nitrogen, are burned before being exhausted. If the gas furnace were to fail, then during some modes of operation H ₂ and CO could be released from the stack. The stack is 14 meters (46 feet) high and is located 118 meters (387 feet) from the nearest member of the public.
Rupture of High-Pressure Piping	Much of the TBPP equipment that would be placed in the annex as part of the Proposed Action is operated at high pressure, up to 1,000 psig. If equipment piping were to rupture, a cloud of flammable gas would form. If the cloud were to come into contact with an ignition source, it could deflagrate.

Table B-5. Potential Hazards and Installed Safeguards (continued)

Loss of Inerting in Vent System	If inerting were lost in the vent system, concentrations of explosive gases could build up. If ignited, a detonation of the piping or vessels in the vent system could occur. The oxygen detector and nitrogen gas flow into the vent system is monitored on the control panel.
Gas Leaks	For much of the system, the gas pressure is near atmospheric pressure, minimizing the likelihood of a significant gas leak. Should a leak occur, the material nearby is not flammable so even if the leak occurred at above the auto-ignition temperature of the gas, the small flame that would occur would not cause any damage. If a leak occurred in the high-pressure section in the annex, the equipment in the annex is built to explosive safety standards to minimize or eliminate the presence of ignition sources.

B.3.2 Postulated TBPP Accident Scenarios

The proposed TBPP would be subject to the accidents considered in the current TCUF plus two others. The two additional accident scenarios are Rupture of High-Pressure Line from Synthesis Reactor (Scenario 5), and Loss of Cooling to Synthesis Reactor (Scenario 6).

Scenario 5. Rupture of High-Pressure Line from Synthesis Reactor

The synthesis reactor would operate at 1,000 psia and 570 °F. At these elevated pressures and temperatures, the rupture of a process line during the lifetime of the facility is considered “remote”. If such a rupture did occur, it is anticipated that only the contents of the synthesis reactor, 60 liters (16 gallons) of gas, would be released. Because the design of the system has not been finalized, the location and number of isolation valves placed in the system to prevent depressurization in one area from escalating into a plant-wide event cannot be specified. This accident scenario is considered a representative depressurization scenario that could occur at one of several locations. The volume released in this scenario should be considered representative and, because the consequences show the impacts to be low, it can be stated with some certainty that even if there were locations where larger releases were possible, no impacts to workers or to the public are anticipated.

Scenario 6. Loss of Cooling to Synthesis Reactor

The production of ethanol using the Fischer-Tropsch process is highly exothermic. The temperature in the reactor is controlled by cooling water circulating through the reactor in tubes. While operating at a lower pressure than the process tubes, these cooling water tubes could also fail external to the reactor, causing a loss of coolant to the reactor. If there were no heat sink to remove the heat of reaction, the internal temperature and pressure in the synthesis reactor would build up rapidly and the vessel would fail catastrophically. Missiles could be generated from the explosion. Under Option 1, these missiles would be contained by the building structure, but under Option 2, they could travel some distance because the operation would not be confined in a building. In addition, if the facility were exposed to the elements, pipe failures from water freezing during very cold periods could occur at a much higher frequency.

Because the cooling water system is operated at a relatively low pressure and temperature, the likelihood of a pipe failure is much lower than the likelihood that one of the process pipes would fail. Most failures, if they did occur, would be small leaks that would not cause any temperature or pressure excursions in the synthesis reactor. However, pipe failures have occurred, normally because of unrealized damage during a maintenance activity. Thus, the likelihood of this accident is considered “extremely remote”. However,

under Option 2, where the equipment would be operated in the open, the number of events that could cause pipe failures (e.g., freezing) would be higher, so the likelihood of a loss of cooling accident would certainly be higher. However, that likelihood is probably not two orders of magnitude higher, so it is still reasonable to assume that the frequency of a loss of cooling accident remains “extremely remote.”

B.3.3 Detailed (Bounding) Accident Analyses

The quantification of these accidents uses information on the chemical composition, operating temperatures, pressures, and mass flow rates from an NREL report authored by Phillips et al. (Phillips 2007). While the flows shown in the report are for a much larger facility, the temperatures and pressures reflect those that would occur in the proposed integrated TCUF/TBPP. For preparing this accident analysis, the guidance given by the staff that authored the NREL report was to divide flows cited in the Phillips report by 4,000 in order to derive an estimate of the flows that would occur in the proposed TCUF/TBPP when it was operating to convert syngas into ethanol in an integrated process. All assumptions used in these bounding analyses are based on the information in the Phillips report.

Analysis 5. Rupture of High Pressure Line from Synthesis Reactor

If the high-pressure line ruptured, the gas in the synthesis reactor would be rapidly discharged. The assumption is being made that isolation valves would close, limiting the volume of the discharge to the volume in the synthesis reactor, 60 liters (16 gallons). Because the exit from the vessel is at a temperature of 570 °F and a pressure of 986 psia, the volume of the material after it was released would be much greater than 60 liters (16 gallons). As the material was released, it would essentially expand adiabatically, resulting in significant cooling of the gas. The equation governing the expansion is:

$$T_1 \cdot P_1^{\frac{1-\gamma}{\gamma}} = T_2 \cdot P_2^{\frac{1-\gamma}{\gamma}}$$

Most of the gases in the synthesis reactor would be diatomic, therefore $\gamma = 1.4$ if $T_1 = 1030$ °R (degrees Rankine), $P_1 = 1001$ psia (986 psig), and $P_2 = 14.6$ psia. After the adiabatic expansion, the temperature would be $T_2 = 308$ °R or -151 °F. Of course, the temperature would not go this low because the expansion would not be totally adiabatic. As they expanded, the released gases would do work against the air and would also mix with the air. While the alcohols would condense if the mixture cooled much below room temperature, at room temperature the vapor pressure of alcohols in the mixture would be greater than their molar concentration, so no condensation would occur. Thus, it can be assumed that if released, the entire mixture would eventually form a flammable gas cloud. At standard temperatures and pressures and with no mixing, the volume of the release would be 273 liters (72 gallons). However, this volume would contain no oxygen, so no fire or deflagration would be possible. In fact, if the volume of the release were double this volume, 546 liters (144 gallons), the oxygen concentration would only be 10.5 percent, assuming uniform mixing. Should the cloud ignite, it would be in a room designed to have no ignition sources, and the heat of combustion would heat up the air in the room, resulting in a pressure pulse. Again, considering adiabatic conditions and no temperature loss to equipment or the room walls, the air in the room would heat up about 10 °C, increasing the pressure in the room about 0.5 psi. The room and the ventilation system would more than dissipate that deflagration.

Toxic CO would be released if the deflagration did not occur. There would be an estimated 12 gram moles of gas in the synthesis reactor, and the concentration of CO would be 28 percent; therefore, a total of 96 grams of CO would be released if the piping failed. The duration of the release is assumed to be 10 minutes, based on six air exchanges per hour. Based on an ALOHA run, the CO plume concentration

would be 0.48 ppm at 112 meters (367 feet) from the plant and 6.3 ppm at 30 meters (98 feet) from the plant. Both of these concentrations are well below the ERPG-2 CO concentration of 350 ppm.

Because the design of the proposed TBPP is not final, there is the possibility that there would be areas of the facility where more than 60 liters (16 gallons) of high-pressure gas would be released. However, based on the ratio of the concentration at 30 meters to the ERPG-2 value, the release could be orders of magnitude higher without endangering the public or the non-involved workers. Thus, no emergency response measures need to be taken to protect non-involved workers or the public from this accident. The consequences of this accident, other than the damage to the equipment, are considered minor, and since the area would not be occupied while the equipment is running, the accident would pose no danger to involved or non-involved workers or to the public.

Analysis 6. Loss of Cooling to Synthesis Reactor

If loss of cooling to the synthesis reactor were to occur, the reactor would heat up and eventually its shell, already operating at about 1,000 psia, would rupture. Assuming it would fail at 1,500 psia and that its volume was 60 liters (16 gallons), then the energy from the explosion would be the equivalent of an explosion associated with 330 grams of TNT. An explosion of 330 grams of TNT would do extensive damage to the equipment and the facility. In addition to catastrophic reactor vessel failure, it is highly likely that some of the process piping would be damaged and that a fire would result.

Option 1 assumes that the facility would not be occupied and would be structurally separated from the building containing the control room; therefore, injuries to involved workers are not anticipated. However, if workers were present, it is highly likely that they would be seriously injured or killed. Under Option 1, the FTLB or annex building walls would absorb the pressure pulse and contain any shrapnel or missiles generated by the explosion. Consequently, injuries to non-involved workers or the public are not anticipated.

Option 2 assumes that no containment building is built, suggesting that missiles from a vessel rupture could travel some distance and potentially cause injuries, including ruptured eardrums, and broken glass damage. Figure 17-104 in Lees relates the probability of eardrum rupture to the peak overpressure from a vessel failure. Figure 17-60 correlates the scaled peak overpressure to the scaled distance. Assuming the vessel failure is equivalent to the explosion of 336 grams of TNT, then at 30 meters (98 feet) the scaled distance is 43, R_{bar} is 12.1, and, using Figure 17-60 in Lees, the peak overpressure is 1,500 Pa. From Figure 17-104, this overpressure is well below the threshold for eardrum rupture, which is 200,000 Pa. When a distance of 112 meters (367 feet) is assumed, the overpressure is 250 Pa, well below the threshold for both eardrum rupture and glass breakage.

Regarding the potential for injuries from missiles or fragments, the analysis results are much more complex and uncertain because, as stated by Baker, if the failure is ductile rather than brittle, fragments often do not form. A ductile failure resembles a tear, whereas a brittle failure results in pieces or fragments. A ductile failure shows a substantial degree of deformation before failure, while a brittle failure simply snaps after little or no deformation. If the TBPP were built, it is anticipated that the construction materials would be selected to minimize the likelihood of brittle failures to the vessels. However, when processing H_2 at high temperatures and pressures, this may present a difficult design challenge. Thus, it is appropriate to assume that some brittle failures could occur. Some of the models that have been developed assume that the fragments are two equal parts of the vessel and that they are propelled in opposite directions as a result of the failure.

For this accident analysis, it is assumed that large fragments from a brittle failure would be contained by a dedicated “containment structure” around the high-pressure reactor. One design option for a containment structure would be to surround only the high-pressure reactor and meet strength and size specifications sufficient to contain the reactor or pieces of the reactor in the event of an explosion or other overpressurization accident. The containment structure would have to be strong enough to withstand impact but would also have enough open vent area to allow the gases to escape. The close fit of a containment structure around the reactor would prevent the ruptured/venting reactor, or its pieces, from accelerating to high velocities. This would prevent an exploding reactor or reactor fragments from developing high kinetic energy and penetrating ability. Final design of this safety feature would occur before facility construction began.

In the case of the synthesis reactor, it is possible that some of the tubes in the reactor would be separated from the vessel and that these tubes would be the fragments released from a vessel explosion. The release of such fragments is considered in more detail in these analyses.

Although the TBPP has not been fully designed, it is assumed that the reactor vessel would be about 20 centimeters (8 inches) in diameter and 2 meters (6.5 feet) long and that it would weigh about 100 kg (220 lbs). It is assumed that the tubes would weigh about 1 kg (2.2 lbs) each and that six tubes would be released in the explosion. The key question is: “How far would the tube fragments fly after being released?”

Using the method developed by Baker, the first step is to estimate the velocity of the fragments produced from the explosion. If the vessel weighed 100 kg (220 lbs) and broke into two pieces, the velocity of the two pieces is estimated (using Figure 4-2 in Baker) to be 34 meters (111 feet) per second, or about 75 miles per hour (mph). If it broke into many fragments, the velocity of the fragments could be as high as 100 meters (330 feet) per second (over 220 mph), using the same figure.

The range of the fragments is estimated using Figure 4-5 developed by Baker. It relates the scaled initial velocity to the scaled range and uses a dimensional parameter relating lift to drag. It is conservative to assume no lift, because lift elevates the trajectory and results in a shorter range. Using an initial velocity of 100 meters (330 feet) per second and an assumed weight for the fragment of 1 kg (2.2 lbs), the scaled velocity for a 1-centimeter (0.4-inch) diameter, 2-meter (6.5-foot) long cylinder having a drag coefficient of 1.2 is 93 meters (305 feet) per second (again from Baker), and from the curve the scaled distance is 6.¹ This translates to a distance of about 90 meters (295 feet). A similar distance was obtained for a 100-kg (220-lb) projectile with an initial velocity of 34 meters (111 feet) per second. For a 0.5-kg (1.1-lb) fragment, the range was about 60 meters (197 feet).

Clearly, there is substantial uncertainty in these calculations because the exact weight and shape of the fragments are not known. However, the sensitivity analyses consistently indicate that projectile ranges would be in the tens of meters. Thus, it is believed possible that missiles could fly 30 meters (98 feet), but it is believed highly unlikely that they would fly beyond 100 meters (330 feet). Because of the speed of these fragments, they could cause serious, perhaps fatal, injuries if one of them struck an individual.

¹ “Scaled distance” is a dimensionless factor used to calculate explosive effects at distance, including ranges for fragments originating from a blast.

B.3.4 Summary of Accident Analyses for Proposed TBPP and TCUF Upgrades

The current facility has been built to meet all applicable standards for the safe operation of the equipment and protection of workers. Under Option 1, the proposed TBPP and TCUF upgrades would be constructed and operated to the same standards. Furthermore, due to the dangers inherent in operating equipment at high temperatures and pressures, no operators would be in the annex whenever the process would be operating.

Under Option 1, where the FTLB or an annex building (containment) would be constructed, the many safety features incorporated into the existing TCUF and proposed TBPP and TCUF upgrades would continue to protect workers and equipment from standard industrial accidents such as spills of flammable chemicals. The same safety features frequently act to prevent the progression of an incident to more serious accidents—e.g., a spill that leads to a fire that leads to failure of process equipment. The safety features also serve to protect the workers from the hazards associated with such spills or process upsets. If the TBPP were built as proposed, there are adequate safety features to prevent the occurrence of most accidents and, should they occur, to protect or mitigate their consequences.

Based on the analyses in this appendix, DOE and NREL acknowledge that under Option 2, where an annex building would not be built, a failure of the synthesis reactor could result in injuries or fatalities to non-involved workers if they were struck by flying fragments. Even though the probability of such an accident is “extremely remote”, such consequences are unacceptable. Therefore, this option has been eliminated from further consideration by DOE and NREL for the TBPP.

Before the TBPP would be constructed within the FTLB or in a stand-alone building, as proposed under Option 1, final building and equipment design efforts would be integrated with detailed safety and hazards risk analyses. This design approach would identify all safety features, equipment, and structural elements of the building that would be required to prevent the occurrence of most accidents and, should they occur, to protect or mitigate their consequences. All the accidents of concern have an “extremely remote” frequency of occurrence.

Table B-6 summarizes the accident scenarios assessed in detail in this appendix in terms of their likelihood of their occurrence; and the predicted impact to the off-site public, the involved worker (individual working in the TCUF), and the uninvolved workers that work elsewhere on the STM site.

B.4 REFERENCES

- ANSI (American National Standards Institute). 1998. *Airborne Release Fractions at Non-Reactor Nuclear Facilities*. ANSI/ANS-5.10-1008. American Nuclear Society, La Grange Park, IL.
- Baker, W.E., et al. 1978. *Workbook for Estimating Effects of Accidental Explosions in Propellant Ground Handling and Transport Systems*, NASA Contractor Report 3023, Southwest Research Institute, San Antonio, Texas, August.
- Diebold, James P. 1997. *A Review of the Toxicity of Biomass Pyrolysis Liquids Formed at Low Temperatures*. NREL/TP-430-22739. National Renewable Energy Laboratory, Golden, CO, April.
- Lees, Frank P, ed. 1996. *Loss Prevention in the Process Industry*. Second Edition. Oxford Publishing. London, Great Britain.

Table B-6. TCUF/TBPP Accident Consequence Summary

Accident Scenario	Likelihood of Occurrence	Impact to the Off-site Public	Impact to Involved Worker	Impact to Uninvolved Worker
Current TCUF Configuration (No Action)				
Spill or rupture of a 114-liter (30-gallon) drum of pyrolysis oil, resulting in atmospheric release	Full spill: Remote	ERPG-2 limits not exceeded for any single chemical, nor would the cumulative effect of all chemicals exceed ERPG-2 limit.	For unprotected workers, health effects would be anticipated. However, workers are trained in emergency response, and personal protective equipment is available to reduce the potential of permanent health effects.	ERPG-2 limits are exceeded for formic acid and acetaldehyde, but effective emergency response would limit exposure time to less than an hour. No permanent health effects would be anticipated.
Release of syngas to the atmosphere	Extremely Remote	Well below the ERPG – 2 limit. No health effects would be anticipated.	For unprotected workers, health effects would be anticipated. However, workers are trained in emergency response, and personal protective equipment is available to reduce the potential of permanent health effects	No health effects to a non-involved worker would be anticipated.
Backflow of dodecane into the fluidized bed reactor, resulting in a fire and explosion	Extremely Remote	Facility walls would prevent any impacts to a member of the public.	Explosion and serious injury to the operators.	Facility walls would prevent any impacts to non-involved workers.
Failure of inerting in the off-gas system, resulting in a fire and explosion	Extremely Remote	Facility walls would prevent any impacts to a member of the public.	Detonation would do extensive damage to equipment. A fire could ensue.	Facility walls would prevent any impacts to non-involved workers.
TBPP and Upgraded TCUF (Proposed Action)				
Rupture of high-pressure line from synthesis reactor, resulting in a fire and atmospheric releases	Remote	Facility walls would be adequately designed to prevent any impacts to a member of the public.	Damage to the equipment would be considered minor. Accident would pose no danger to workers.	Facility walls would prevent any impacts to non-involved workers.
Loss of cooling to synthesis reactor, resulting in a fire and explosion	Extremely Remote	Facility walls would be adequately designed to prevent any impacts to a member of the public.	Explosion would cause extensive damage to the equipment and the facility. It is highly likely that some of the process piping would be damaged, and a fire would ensue. Because the annex is not occupied and is physically separated from the building containing the control room, injuries to workers are not anticipated.	Facility walls would prevent any impacts to non-involved workers.

ERPG = Emergency Response Planning Guideline.

- NOAA (National Oceanic and Atmospheric Administration). 2004. *Areal Locations of Hazardous Atmospheres (ALOHA), User's Manual*, Version 5.3.1, U.S. Environmental Protection Agency and the National Oceanic and Atmospheric Administration, March.
- NREL (National Renewable Energy Laboratory). 1998. *Safe Operating Procedures for the Thermochemical Process Development Unit at FTLB High Bay*. SOP 62000980. National Renewable Energy Laboratory, Golden, CO.
- Phillips, S., et al. 2007. *Thermalchemical Ethanol via Indirect Gasification and Mixed Alcohol Synthesis of Lignocellulosic Biomass*. NREL/TP-510-41168. National Renewable Energy Laboratory, Golden, CO, April.
- Timmer, Helmut, and Friedrich Lettner. 2005. "Explosion Parameters and Explosion Protection in Biomass Gasification plants,." *Proceedings of the International Workshop, Health, Safety and Environment of Biomass Gasification*. Innsbruck, Austria, September 28.

APPENDIX C DRAFT SEA COMMENTS AND RESPONSES

DOE mailed the notice of availability of the draft SEA to the businesses, agencies, and organizations listed in Appendix A. In addition, DOE mailed the notice to all known Pleasant View residential addresses.

DOE reviewed all comments received on the draft SEA. The comments are summarized and responded to in this appendix.

Traffic

Comment: Commentors expressed interest in the effects that a new site entrance at Moss Street would have on traffic going through the neighborhoods.

Response: An STM site entrance from the south, such as Moss Street, is not anticipated to pass through the neighborhoods but could potentially follow an existing Xcel Energy easement for a high-pressure natural gas line. Currently, DOE and NREL are only exploring the concept of opening an alternative entrance into the site and have more information-gathering to do before making any solid plans. A NEPA review process, including traffic studies, would need to be completed before any final plans are put in place.

Comment: Commentors expressed concern over increased traffic on South Golden Road resulting from opening an additional site entrance and the need for improvements to that road.

Response: For the proposed actions assessed in this SEA, the analyses have determined that a new site entrance would not be needed to mitigate traffic impacts. In the near term, there would be no appreciable increase in traffic on South Golden Road. However, as build-out plans continue for the STM site, additional NEPA analyses will be generated which would include a new entrance and the subsequent need for improvements to South Golden Road.

Comment: Commentors suggested that as a part of its traffic mitigation actions, DOE/NREL could launch an environmentally friendly transit/parking system in concert with other local municipalities and regional agencies that will set a greener commuting example for employers to follow.

Response: DOE and NREL have begun discussions with the City of Golden and the Colorado School of Mines to examine alternatives to reduce the need for additional parking, to reduce pressure on local roads, and to improve air quality. One of the alternatives under discussion is a shuttle service, jointly funded by all the above entities, that would serve the Golden/Denver West area and eventually connect with the light rail line ending near the Jefferson County government complex. Although we are in the very early stages of discussions regarding this alternative, all parties have expressed interest in further investigating the options.

Economic Impact

Comment: Commentors requested that DOE assess the economic impact that would result from vacating office space in the Denver West Office Park. Additionally, commentors felt that funding for road improvements that only served NREL is inappropriate when the existing roads in the Denver West Office Park can handle the traffic.

Response: DOE and NREL have engaged in discussions with the owners of the Denver West Office complex and will continue this dialogue as the new construction is completed. DOE and NREL intend to give the Denver West management plenty of notice (over 2 years) to minimize the impacts of the departure of DOE and NREL staff. While DOE and NREL have a good working relationship with the Denver West owners and management, they do not have significant negotiating leverage that would allow for savings of significant amounts of money over the average rental costs of the area office buildings. When DOE and NREL held preliminary discussions with the Denver West management, Denver West did not indicate that they would have difficulty leasing the vacated space.

A cost-benefit analysis completed for the Research Support Facilities (RSF) showed that the government would save over \$166 million over the expected life of the building versus the “No Action Alternative” (continued leasing). Additionally, the United States Congress and the Department of Energy agree that building a facility is the most economical decision for NREL to accommodate their current mission and planned growth.

Alternative Design

Comment: Commentors felt the ratio of space to number of employees (275 to 375 square feet of space per head) should be smaller and that NREL should make more efficient, economical, improved use of existing resources.

Response: It was assumed in the SEA that the building could be up to 300,000 square feet to ensure that the largest building possible was analyzed. The actual building size would very likely be less than that. The majority of the personnel in the RSF would have an office area of 80 to 100 square feet, with senior staff and manager offices being approximately 120 square feet. Common areas in the building would add to the square footage per person. Common areas include conference rooms, stairways, corridors, a library, restrooms, utility and storage areas, loading docks, fire systems and electrical rooms, computer data center, communications room, lunch rooms, recyclable containment area, file and record storage, and the lobby and reception area. Until the final design is complete, it is not possible to give specific area per person; however, it is anticipated that the overall square footage per person would be significantly less than the current leased space in Denver West and would be much less than industry standards. NREL’s mission and goal for this new office area is to build a “Showcase Facility” that will demonstrate to industry methods for building an economically affordable building that incorporates the state of the art in energy efficiencies and sustainable building performance and provides a creative work environment for its employees.

Comment: Commentors requested that detailed design be completed now and assessed in the SEA.

Response: DOE and NREL would develop the RSF via a design-build contract process. This means that DOE and NREL would enter into a contract for the design and construction of the RSF prior to the design phase of the process. Per DOE NEPA implementing regulations, the SEA was completed in advance of DOE and NREL entering into a contract for the RSF and therefore prior to the detailed design phase of the project.

Visual Impacts

Comment: Commentors living in the neighborhood immediately adjacent to Pad 1 expressed great concern over any building construction that would impair their view of the mountains to the west.

Response: As shown in the SEA, construction of an RSF building more than one or two stories high on Pad 1 would obstruct the mountain views to the west from residences on Kendrick Street that are immediately adjacent to Pad 1. RSF construction on either Pads 2 or 3, located to the north of the Kendrick Street residences, would be consistent with other STM facilities and would not obstruct the neighbors' mountain view. Based on the analyses in the SEA, DOE is not currently proposing permanent building construction on Pad 1.

Existing Noise Impacts

Comment: Commentors noted that there is an engine or fan in an existing building near the east end of the STM site that emits an annoying amount of noise and requested that the noise be reduced during quiet family evening hours from 6 PM to 10 PM. They noted that it is especially quiet in their neighborhood during these hours, so the fan/engine noise becomes even more disturbing. They suggested that perhaps a noise barrier could be built to deflect the sound back toward South Table Mesa.

Response: NREL has determined that the noise described comes from the Science and Technology Facility. Although this SEA does not address the Science and Technology Facility, NREL recognizes that the sound levels from the ventilation exhaust stacks are higher than anticipated. Therefore, a project to add sound dampening "mufflers" to the stacks has been initiated and is scheduled for completion by July 2008. The mufflers are designed to achieve a 15-decibel noise reduction, which will cut the noise emissions from these ventilation stacks by well over 50 percent. Additionally, the proposed RSF would be an office building and would not require the large exhaust ventilation system required in the Science and Technology Facility.

Land Transfer

Comment: Commentors noted their dissatisfaction with Jefferson County's failure to provide the public an opportunity to comment on the land transfer agreement between Jefferson County, the State of Colorado, and DOE. That agreement exchanged parts of Camp George West for the trail and conservation easement on South Table Mountain.

Response: The land transfer referenced was authorized by an act of the General Assembly of the State of Colorado in House Bill 96-1072 (April 17, 1996). This bill authorized the state and the county to enter into a conservation easement and land transfer with the United States Department of Energy at the NREL South Table Mountain site. DOE worked with the State of Colorado, Jefferson County, and Pleasant View and local elected officials in furthering the land transfer.

Biomass Feedstock

Comment: Commentors noted that the Jefferson County Fairgrounds generate large quantities of manure waste, comprised of wood chips, shaving, straw, animal waste, etc. and questioned whether these materials could be used in the Thermochemical Biorefinery Pilot Plant.

Response: The Thermochemical Biorefinery Pilot Plant (TBPP) at NREL would be designed to convert synthesis gas (a mixture of hydrogen and carbon monoxide) into liquid transportation fuels. Initial experiments would focus on the synthesis of mixed alcohols (primarily ethanol), but other fuels are being planned for the future, including diesel fuel and gasoline. The synthesis gas is produced by steam gasification of biomass.

Biomass feedstock to the gasifier consists of many different types of lignocellulosic materials, including forest products and agricultural residues. In the latter category, animal waste and straw could, in principle, serve as feedstock. Significant research on gasification of several different types of animal waste has been carried out at NREL and elsewhere. Our current plans for the gasification reactor coupled to the TBPP are to focus on testing of woody and herbaceous feedstocks, and testing of other materials is certainly not precluded. However, because of the nature, timing, and focus of the research, NREL does not foresee an opportunity to accept manure waste from Jefferson County Fairgrounds as feedstock.

Conservation Area

Comment: Commentors asked for clarification on the location of the conservation lands on the STM site.

Response: The 177-acre conservation area is on the mesa top and slopes. It is shown in Figure 2-2 of the SEA as Site Development Zone # 2 (Conservation Area).

Comment Periods

Comment: Commentors attributed the lack of scoping comments to inadequacies in the mailing and the shortness of the comment period.

Response: DOE and NREL used NREL's most current mailing list to distribute the scoping letter and have accepted comments throughout the scoping, document preparation, and draft EA review period. DOE and NREL also published a Legal Notice in the Golden Transcript for the scoping period as well as the Notice of Availability for the Draft EA, and distributed Notices of Availability for the Draft EA to the local postal routes. The most current information regarding the environmental assessment process is maintained on the DOE Public Reading Room website: http://www.eere.energy.gov/golden/Reading_Room.aspx. The duration of the comment periods provided for this SEA are consistent with DOE's NEPA regulations and are typical of those used throughout the DOE system.

Public Access

Comment: Commentors noted that the SEA does not mention impacts to recreational users of the trail/easement to which the public has access on the STM site.

Response: DOE and NREL are working with Jefferson County to maintain public access to the trail system. The trail system is currently accessible via Denver West Parkway. A trail has been constructed from the ball fields up to the South Table Mesa trail system. A gate that is currently locked, preventing access from the ball fields to the trail system, will be unlocked as soon as NREL completes a site security fencing project.