

Process for Transition of Responsibilities for Formerly Utilized Sites Remedial Action Program Sites from the U.S. Army Corps of Engineers to the U.S. Department of Energy for Long-Term Surveillance and Maintenance

C. Clayton, Program Manager
DOE Office of Legacy Management, Washington, DC

M. Widdop, Project Manager
S.M. Stoller Corporation, Grand Junction, CO 81503

ABSTRACT

The U.S. Department of Energy (DOE) Office of Legacy Management (LM) is the long-term custodian of sites remediated under the Formerly Utilized Sites Remedial Action Program (FUSRAP). The U.S. Army Corps of Engineers (USACE) is responsible for characterization, assessment, remedy selection, and remedial action of FUSRAP sites. Site responsibilities are transferred from USACE to DOE-LM when the implemented remedy is demonstrated to be functioning as designed. Coordination of site transfer follows prescribed processes to ensure that DOE acquires the knowledge and information to maintain the site remedy and site protectiveness.

INTRODUCTION

Program Background

Beginning in the early 1940s, the Manhattan Engineer District (MED) and its successor agency, the U.S. Atomic Energy Commission (AEC), conducted research and development of nuclear energy for weapons and energy production. Initially, the Federal Government did not have the facilities or metallurgical expertise to conduct this work and contracted with private industry to provide research, ore processing, refining, and fuel element fabrication support. As government-owned facilities were established, AEC released the contracted sites. Release consisted of surveying the contracted sites and decontaminating them to comply with then-current standards for radiological health and safety. By the early 1970s, cleanup standards had become more stringent and conditions at some sites had changed. In 1974, under authorization of the Atomic Energy Act [1], AEC initiated the Formerly Utilized Sites Remedial Action Program (FUSRAP) to assess these sites and to ensure that they were protective of human health and the environment. In 1977, the U.S. Department of Energy (DOE) assumed responsibility for administration and execution of FUSRAP.

AEC and its successor agencies reviewed records and radiometric surveys for more than 600 candidate sites where nuclear energy and weapons work was performed for the Federal Government. Forty-six sites were identified that were eligible for and required cleanup of radioactive contamination remaining from MED and early AED activities (Figure 1). Site data were captured in an internal database and in site files. Documented eligibility determinations, radiological survey and remediation reports, and certification documentation are available to

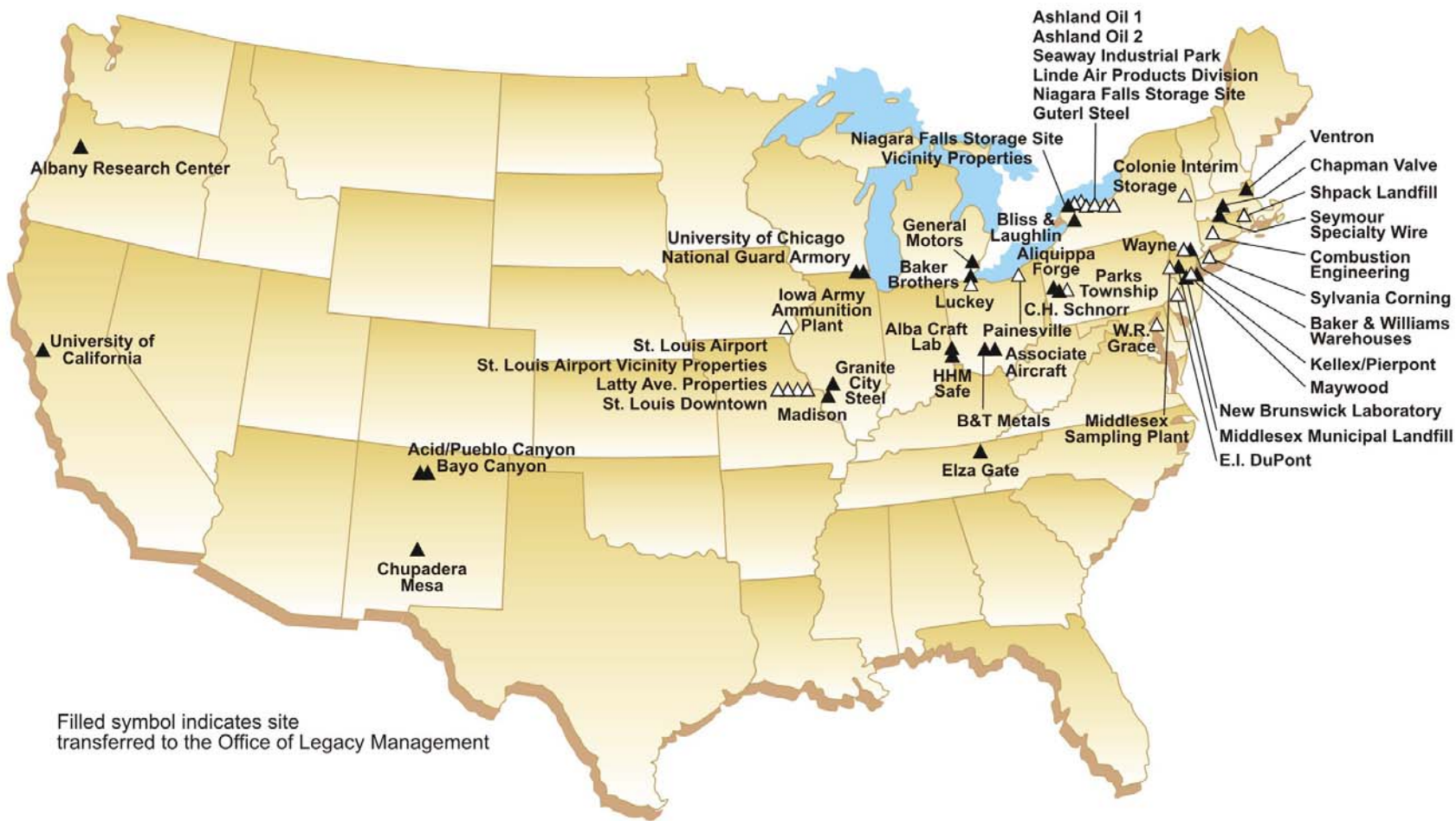

Fig. 1. Locations of eligible FUSRAP sites as of February 2006.

WM'06 Conference, February 26-March 2, 2006, Tucson, AZ

the public through the Considered Sites Database (the database can be accessed at <http://csd.gjo.doe.gov/index.cfm>).

DOE began limited cleanup of FUSRAP sites in 1979, and major cleanup projects were under way in 1981. Between 1981 and 1997, DOE remediated 25 of the 46 sites.

Congress assigned responsibility for all FUSRAP field activities to the U.S. Army Corps of Engineers (USACE) through the 1998 Energy and Water Development Appropriations Act.[2] DOE retained responsibility for determining site eligibility for remediation under FUSRAP and for performing long-term surveillance and maintenance (LTS&M). This assignment of responsibilities was clarified in the 1999 Energy and Water Development Appropriations Act.[3] USACE was directed to conduct remedial actions in accordance with the Comprehensive Environmental Response, Compensation, and Liability Act [4] and the National Oil and Hazardous Substances Pollution Contingency Plan.[5]

Since 1997, four more sites were deemed eligible or were added to the program by congressional order and were scheduled for remedial action by USACE. Three other sites were eligible for FUSRAP remedial action, but contaminant levels did not exceed authorized limits, and USACE notified Congress that the sites required no further action. USACE is conducting assessment activities on three sites that DOE has determined are eligible for remedial action. Figure 2 presents significant events in the history of FUSRAP.

FUSRAP Site Eligibility Criteria

Site eligibility for FUSRAP remedial action is contingent on the following criteria:

- The work performed for MED or AEC involved radioactive materials;
- There is a reasonable probability that radioactive contamination may exist at the site;
- The Federal Government was responsible for control and decontamination of residual contamination. (Some AEC contracts contained a “hold harmless” clause, under which AEC was not responsible for remediating residual contamination that might remain from the contracted activities); and
- Contaminant levels at the site pose an unacceptable risk or exceed applicable standards.

Congress may direct DOE to include a site, which will obviate the need for an eligibility determination and lead directly to USACE assessment activities.

Memorandum of Understanding

In 1999, USACE and DOE signed a Memorandum of Understanding (MOU) to define FUSRAP execution and administration.[6] The MOU established roles and responsibilities, defined limits of authority for the two agencies, and specified that DOE will determine site eligibility and will conduct post-closure LTS&M. USACE will perform risk assessments and characterization;

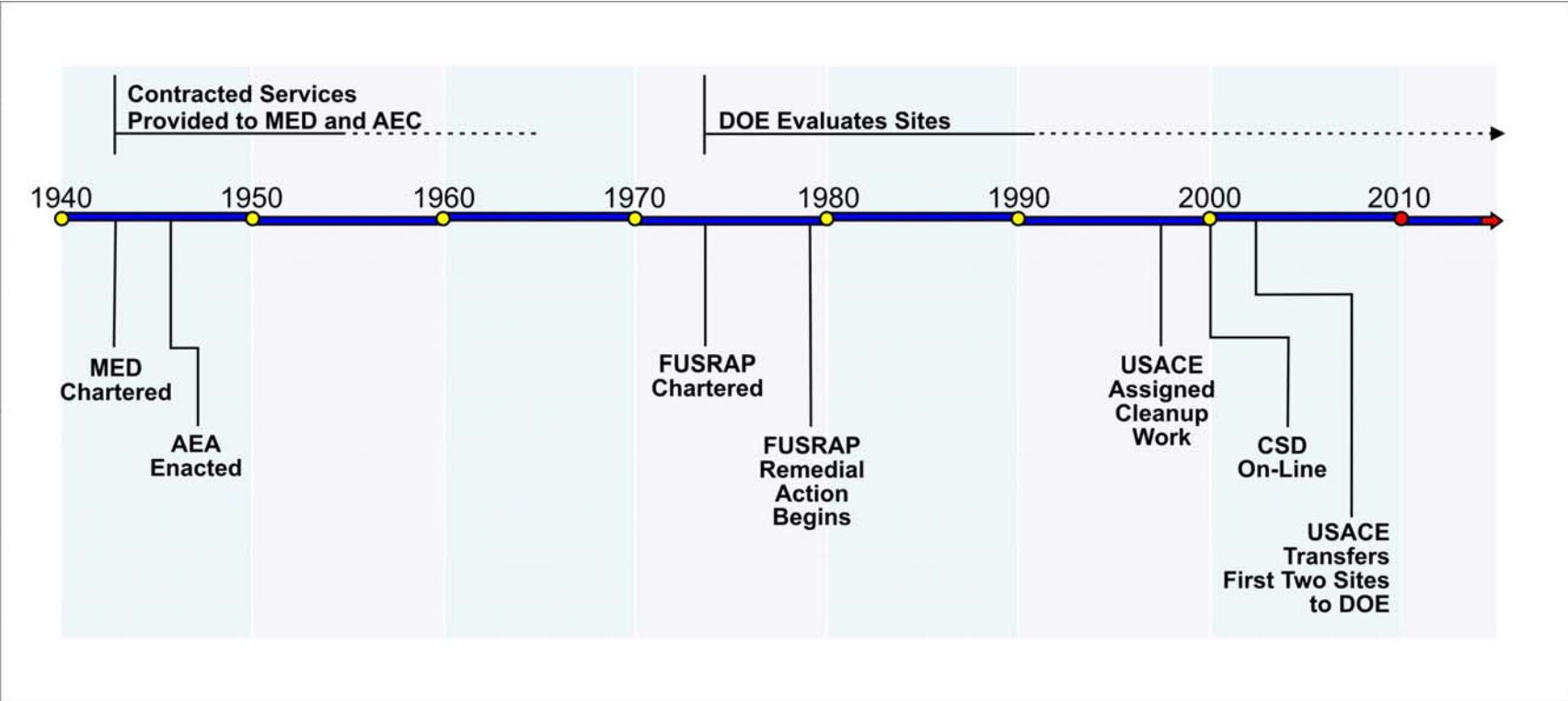

Fig. 2. FUSRAP timeline.

identify applicable cleanup standards; determine if a site poses an unacceptable risk to human health or the environment or if contaminant levels exceed applicable standards; select the remedy; conduct required cleanup activities; and obtain regulator concurrence that remedial action is either not required or that cleanup actions result in the site complying with cleanup standards. USACE will implement required institutional controls¹ and will assume administrative responsibility for the site from the time DOE finds the site to be eligible until USACE publishes a declaration of remedial action complete or notifies Congress that remedial action is not required.

TRANSITION PROCESS

General DOE Transition Process

DOE-LM established transition guidance that is intended primarily for application to sites remediated by the DOE Office of Environmental Management that will then transfer to LM for LTS&M. However, LM intends to apply the applicable portions of the guidance uniformly to all sites transitioning to LM, including sites remediated by the private sector under Title II of the Uranium Mill Tailings Radiation Control Act of 1978, FUSRAP sites cleaned up by USACE, and sites remediated under other authorities. This guidance, the Site Transition Framework, addresses the following 10 elements [10]:

1. Authorities and accountabilities are assigned and documented;
2. Site conditions are accurately and comprehensively documented;
3. Engineered controls, operation and maintenance requirements, and emergency/contingency planning are documented;
4. Institutional controls and enforcement authorities are identified;
5. Regulatory requirements and authorities are identified;
6. Long-term surveillance and maintenance budget, funding, and personnel requirements are identified;
7. Information and records management requirements are satisfied;

¹The U.S. Environmental Protection Agency defines "institutional controls" as "...nonengineering measures designed to prevent or limit exposure to hazardous substances left in place at a site, or assure effectiveness of the chosen remedy. Institutional controls are usually, but not always, legal controls, such as easements, restrictive covenants, and zoning ordinances." [7]

DOE [8] defines institutional controls as follows:

"Institutional controls may include administrative or legal controls, physical barriers or markers, and methods to preserve information and data and inform current and future generations of hazards and risks. Because of the different needs and objectives for institutional controls and the different types used throughout DOE, the term 'institutional controls' is used in a broader context in this Policy than it may be used in internal and external regulatory requirements or policies established under individual statutes."

The International City/County Management Association offers the following definition of institutional controls.[9] Note that "land use controls" is often used in the context of U.S. Department of Defense property cleanup activities.

"Environmental land use controls (LUCs) -- also known as institutional controls (ICs), activity and use limitations (AULs), and environmental use restrictions (EURs) -- are legal and administrative measures to protect human health and environment from risk based cleanups in which residual contamination is contained on site. LUCs limit human exposure by restricting activity, use, and access to properties with residual contamination."

8. Public education, outreach, information and notice requirements are documented and satisfied;
9. Natural, cultural and historical resource management requirements are satisfied; and
10. Business functions including contractor benefits [are addressed].

LM uses the Site Transition Framework as a comprehensive checklist to identify information gaps and issues that must be resolved. Within each element are specific criteria to be considered. Only those portions of the Site Transition Framework that apply to a given site are applicable to transfer of that site.

The Site Transition Framework is intended to ensure that LM will be informed of necessary requirements for maintaining protectiveness, essential site knowledge is transferred and preserved in DOE records, and stakeholders are informed of the DOE role to provide LTS&M and to respond to inquiries about site conditions. LTS&M activities will range from records management and stakeholder response to inspections, maintenance, monitoring, and management of institutional controls.

While the Site Transition Framework serves to define site conditions, documentation, and the LTS&M elements that must be addressed, it does not prescribe a transition process. Therefore, LM seeks concurrence with the transferring agency to develop a site transition plan, which takes into account site-specific conditions such as timetables, complexity, and the regulatory regime.

DOE assembles a transition team that represents all disciplines required to evaluate the various aspects involved in transitioning a given site. The team may draw on subject matter experts in the fields of human health and ecological risk assessments, hydrology and ground water, remedial action verification, public relations, records management, monitoring and geospatial data management, real and personal property, and project management. The DOE-LM project manager assembles the team and typically calls upon contractor resources for support.

USACE FUSRAP Transition Process

USACE has proposed a draft process for site transition.[11] The USACE process identifies milestones in the site remediation process and prescribes notifications and information exchanges between the two agencies as a site progresses from remedy selection to transition to DOE for LTS&M. The USACE process generally satisfies the requirements of the Site Transition Framework and defines a step-wise progression of events that will culminate in transfer of the remediated FUSRAP site to DOE.

The MOU prescribes a 2-year operations and maintenance (O&M) period beginning when remedial action is complete. USACE retains custody of the site during the O&M period and ensures that the remedy is operating successfully and will remain protective. USACE transitions the site to DOE for LTS&M at the end of the O&M period.

FUSRAP Site Transition Milestones

The USACE transition process recognizes three milestones: (1) approval of the Record of Decision for the site, (2) beginning of a 2-year O&M period upon completion of remedial action, and (3) notification 90 days preceding transition of the site to LM. At each milestone,

USACE transfers designated records to DOE, and both agencies interact to ensure full cognizance of site status and conditions. Other transition activities may include an orientation visit and joint environmental monitoring, interviews with USACE project staff, and participation in public and stakeholder meetings.

At the first milestone, USACE notifies DOE when the Record of Decision is approved and provides the Record of Decision and other pertinent site information. This notification allows DOE to update long-range planning and establish repositories for records and data.

USACE next notifies DOE when remedial action is complete and the site enters the 2-year O&M phase. Completion is marked by regulator concurrence that remedial action goals have been met. At this time, USACE transfers remedial action documents. USACE will monitor the remedy to ensure that the remedy is durable and remains protective, or, in CERCLA terminology, the remedy is “operational and functional.” The U.S. Environmental Protection Agency defines this phase as “activities [that] are conducted after physical construction of the remedy is complete to ensure that it is functioning properly and operating as designed.”[12] This notification has the benefit of allowing DOE to include funding for site LTS&M in the annual budget request to Congress. The 2-year lead time is required to accommodate the federal budget process.

The third milestone, O&M complete, occurs 90 days before the end of the 2-year O&M period. USACE provides the remainder of the Administrative Record and other site documents to DOE. USACE staff members are available for consultation, and DOE takes this opportunity to acquire any last institutional knowledge from the USACE remedial action personnel. Regulators, owners, and stakeholders are notified of the imminent transfer of responsibility, and public meetings may be held to facilitate the hand-off.

At each milestone, DOE-LM acknowledges receipt of documents and information. The LM project team draws upon the needed expertise to evaluate the information and works with USACE to seek answers to questions or resolution of issues raised by the information. LM also logs the information into a site records collection that typically is established before the first milestone is reached and adds pertinent information to the Considered Sites Database.

When notified that site transfer is scheduled and during the O&M period preceding transition, DOE evaluates the final implementation of the remedy and determines post-closure care requirements. DOE defines these in a LTS&M plan. An LTS&M plan generally is not required for a site that is released for unrestricted use.

Before site transition is final, DOE prepares site pages for the public-facing website (<http://www.LM.doe.gov/>). If LM will be required to conduct monitoring as part of the remedy, data management staff members prepare the Site Environmental Evaluation Program (SEEPro) database to receive monitoring results by establishing site records and prepare a site presentation for the Geospatial Environmental Mapping System (GEMS) to provide monitoring results and map data to stakeholders.

PROCESS IMPLEMENTATION

DOE and USACE participate in the FUSRAP Working Group that was initiated in 2001. The purpose of the group is to coordinate the activities of each agency. This coordination allows DOE to conduct timely planning, acquire funding to manage new sites that transfer to LM, create necessary plans and procedures, be aware of stakeholder concerns, and acquire site knowledge. Part of the transition coordination involves keeping informed of site completion schedules. USACE provides this information regularly to DOE, typically early in the fiscal year. The schedule was most recently updated in October 2005 (Table I).

The USACE draft transition process was evaluated after transition of the Madison, Illinois, and Bliss and Laughlin, New York, sites in 2002. DOE determined that the process adequately met the Department's needs for notifications and information transmittal. Figure 3 presents the FUSRAP site inclusion and transition process.

DOE CONSIDERATIONS FOR SITE TRANSITION

LTS&M Requirements for FUSRAP Sites

Remedies for FUSRAP sites are determined by USACE, as stipulated in the MOU. The remedy selection process follows the CERCLA framework and culminates in a Record of Decision that is approved by the regulators.

USACE conveys the remedy to DOE at the first transition milestone, "ROD Complete." At that time, DOE has the opportunity to review the remedy and develop long-term planning that reflects the scope needed to maintain the remedy. This evaluation considers specific activities and their anticipated durations, which provide DOE with assurance that necessary site operations will continue seamlessly through transition to maintain protectiveness, regulatory compliance, and stakeholder confidence.

Protectiveness. The primary mission of DOE-LM is to ensure protectiveness, which is accomplished by maintaining the approved remedy and periodically evaluating the remedy performance. The means of verifying ongoing protectiveness is established at the time of transition and documented in a site-specific LTS&M plan.

Because many FUSRAP sites will be released for unrestricted use, DOE will periodically verify that conditions at those sites remain unchanged. This verification may be accomplished by visiting the site or contacting owners or regulators.

The remedy at other sites may consist of managing an institutional control that restricts a particular site use, such as ground water use or residential use. In those cases, DOE activities to maintain protectiveness may include site visits and periodic contacts with agencies implementing the institutional control, such as a planning commission, public works department, or water well permitting agency. DOE will verify that the implementing agencies and, possibly, the owner or tenant, remain aware of the restriction and the restriction has not been violated.

Table I. USACE FUSRAP site completion schedule.

Site	City	State	Est. Year Const Comp	Est. Year Transferred	Owned By	EPA NPL Site	NRC License	Status 10/2005
Bliss & Laughlin Steel	Buffalo	NY		2002	Private	NO	NO	Transferred
Madison	Madison	IL		2002	Private	NO	NO	Transferred
Wayne Interim Storage Site	Wayne	NJ	2004	2006	DOE	NJ1891837980	NO	ROD and ESD completed, final RA completed in 2003, EPA R2 cert'd constr complete 9/03, 5-yr GW mon required
Painesville Site	Painesville	OH	2007	2009	Private	NO	NO	
Seaway Industrial Park	Tonawanda	NY	2012	2014	Private	NO	NO	
Shpack Landfill	Attleboro	MA	2006	2008	Private	MAD980503973	NO	Estimated; EPA/PRPs to complete RA after USACE removes rad
Ashland 2	Tonawanda	NY	1999	2007	Private	NO	NO	
Ashland 1	Tonawanda	NY	2005	2007	Private	NO	NO	
E.I. Du Pont	Deepwater	NJ	2009	2011	Private	NO	NO	RI for Bldg 845 and F-Corral completed 3/04; char for Cent Drainage Ditch and Bldg J-26 completed 12/03
Linde Air Products Div	Tonawanda	NY	2007	2009	Private	NO	NO	
Colonie Interim Storage Site	Colonie	NY	2007	2009	DOE	NO	NO	
Middlesex Sampling Plant	Middlesex	NJ	2008	2010	DOE	NJ0890090012	NO	
St. Louis Airport Site	St. Louis	MO	2006	2014	Private	MOD980633176	NO	Transfer w/ SLAPS, HISS, and VPs
St. Louis Downtown Site	St. Louis	MO	2010	2012	Private	NO	YES	
W.R. Grace Co.	Curtis Bay	MD	2012	2014	Private	NO	NO	
Harshaw Chemical Company	Cleveland	OH	2010	2012	Private	NO	NO	
Luckey Site	Luckey	OH	2010	2012	Private	NO	NO	
Combustion Engineering	Windsor	CT	2007	2009	Private	NO	YES	
Hazelwood Interim Storage Site/Latty Ave	St. Louis	MO	2012	2014	Private	MOD980633176	NO	
Maywood Interim Storage Site	Maywood	NJ	2012	2014	DOE	NJD980529762	YES	
St. Louis Airport Site Vicinity Properties	St. Louis	MO	2012	2014	Private	NO	NO	
Niagara Falls Storage Site	Lewiston	NY	2014	2016	DOE	NO	NO	
IA Army Ammunition Plant (IAAP)	Middletown	IA	2011	2013	DOD	IA7213820445	NO	
.	Vandergrift	PA	2010	2012	Private	NO	YES	
Sylvania-Corning	Hicksville	NY	Unknown	Unknown	Private	NO	NO	
Guterl Specialty Steel Corp.	Lockport	NY	Unknown	Unknown	Private	NO	NO	
Dayton 6 (Scioto Laboratory)	Dayton	OH	Potential Site		Private	NO	NO	
Dayton Warehouse	Dayton	OH	Potential Site		Private	NO	NO	
Joslyn Manufacturing & Supply Company	Fort Wayne	IN	Potential Site		Private	NO		

Updated 10-24-2005 from information provided by USACE through Chris Clayton and Dayton determination letters

Green text indicates USACE is conducting site assessments and has not decided if remediation is required.

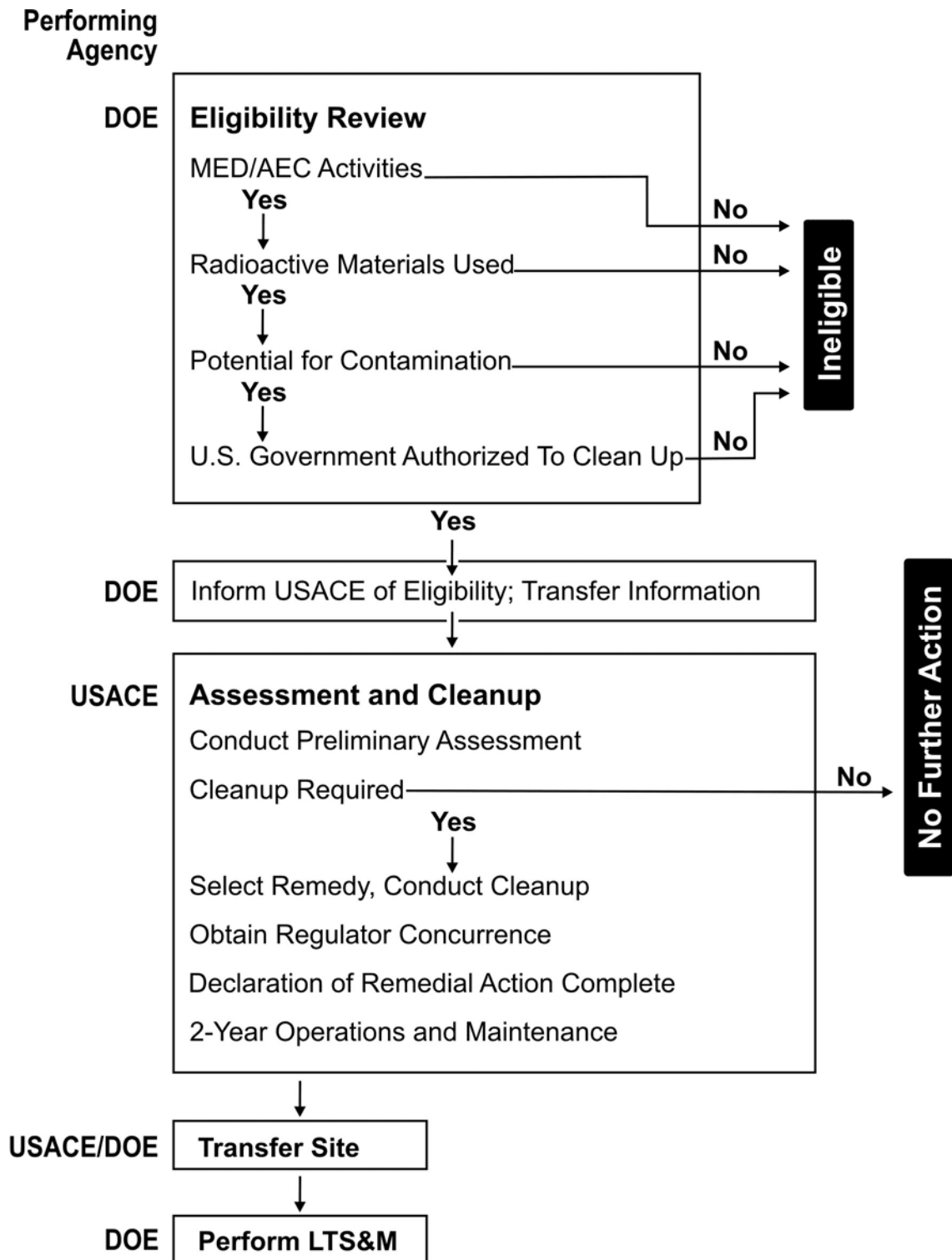

Fig. 3. Site transition process.

Several remediated FUSRAP sites will require active LTS&M operations, such as environmental monitoring or inspections. CERCLA-type periodic reviews of the level of protectiveness resulting from the remedy implementation may be required for sites that cannot be released for unrestricted use. USACE will conduct the initial periodic review, according to the MOU.

Regulatory Compliance. Before site transition is final, DOE will review the regulatory requirements for the site and document requirements in an LTS&M plan. DOE will identify the regulatory agencies and points of contact. DOE will inform regulators of the transition of responsibility for the site, sources of site information, and DOE points of contact.

Stakeholder Support. DOE must maintain stakeholder confidence throughout the transition process. Stakeholders may include the site owner and tenant, local and state government officials, organized citizens groups, and members of the public. LM will request names of key contacts developed by USACE during the cleanup and O&M phases and introductions to key individuals that USACE managers feel would be useful in helping DOE fulfill its LTS&M responsibilities.

The transition phase may include introductions of DOE points of contact at stakeholder meetings. DOE may inform stakeholders of mechanisms for obtaining information and submitting concerns. For sites with more significant stakeholder interest, DOE may develop a specific plan for providing information and support to stakeholders.

At any time after transition or, depending on the issue, during the cleanup and O&M phase, DOE may receive requests for information under the Freedom of Information Act. The DOE-LM information management and retrieval systems provide efficient responses to these requests and any requests that come to the Department through other channels.

DOE-LM maintains information resources on the Internet and many requests for information can be satisfied by referring the requester to the LM website (<http://www.LM.doe.gov/>). DOE posts documents to the LM website as they are received. Many USACE documents are also available on the Internet, and DOE will request these to avoid the duplication of effort involved in rescanning documents to post on the Internet and to allow USACE the option to discontinue maintenance of some of its on-line resources for transitioned sites. DOE evaluates site documentation and seeks to present information that describes site background, activities, final site conditions, risks at closure, and LTS&M program requirements and activities. If monitoring is required for a particular site, DOE also will make the results available through GEMS on the LM website.

One source of information on the DOE-LM website is the Considered Sites Database (CSD) that presents the results of candidate site evaluations to interested stakeholders. DOE will maintain the CSD as sites proceed through the cleanup process through certification. DOE will post information to the CSD for transferring sites, as well as to site-specific web pages on the LM website.

Institutional Knowledge. LM staff members need the opportunity to interact with USACE staff to acquire institutional knowledge of transferring sites. This knowledge is critical to assessing the completeness of site records and data and for implementing LTS&M. Transfer of institutional

knowledge must take place during site transition, while issues are fresh and before remediation staff personnel move on to new projects and records are dispositioned.

Custody of Records. The transition process includes DOE identification of remedial action records that should become part of a permanent site file. Most records are provided by USACE as part of the Administrative Record and remedial action and verification documentation.

Considerable current LM effort is devoted to finding and managing historical records. Before 1997, the DOE Oak Ridge, Tennessee, office managed FUSRAP remedial action activities. When remedial action responsibility was transferred to USACE, DOE transferred all program records to USACE. USACE submitted many of the records to a Federal Records Center but retains custody of the records. DOE and USACE are negotiating supervised access to these records. USACE cannot relinquish custody of the records because they contain sensitive and proprietary program information, such as subcontract documents. At some time in the future, the records should cease to be sensitive, and DOE expects USACE to transfer full custody. Because the records have been scheduled for permanent retention, DOE has no concerns about notification of impending destruction.

Geospatial Data. DOE-LM maintains geospatial data for all sites in LTS&M. These data support many LTS&M activities: management of real property concerns, including institutional controls, real-time dynamic data access for regulators and stakeholders, monitoring, and reporting. LM requests available USACE geospatial data for a site at transition.

Data types that LM requests include monitor well location, construction details, ownership and permit information, property boundaries, extent of assessed contamination and remediated areas, and man-made and natural structures and systems. LM archives these data in a systematic structure and provides real-time stakeholder access to data that are of greatest interest. These data can include drawing files that are not driven by GIS point data.

Monitoring Data. As with geospatial data, LM requests any USACE monitoring data that are available. Electronic data are migrated into LM database systems, process data are checked, and questions are resolved. Data reports are submitted to site records collections, and data may be manually input into the LM database if the transferring agency cannot provide the data electronically. These data are essential for validating ongoing monitoring results.

Site Access. Most FUSRAP sites are privately owned industrial facilities. USACE acquires access to conduct surveys and remedial action. If the remedy requires site access for monitoring, managing institutional controls, or other purposes, DOE must acquire access before the site transition is final to ensure continuity of LTS&M activities.

ACKNOWLEDGMENTS

This work was conducted under DOE contract number DE-AC01-02GJ79491 for the U.S. Department of Energy Office of Legacy Management, Grand Junction, Colorado.

REFERENCES

1. Atomic Energy Act of 1954, 42 *United States Code* (U.S.C.) 2011, *et seq.*
2. Energy and Water Development Appropriations Act of 1998, PL 105-62, 11 Stat. 1326.
3. Energy and Water Development Appropriations Act of 1999, PL 105-245, 112 Stat. 1843.
4. Comprehensive Environmental Response, Compensation, and Liability Act (42 U.S.C. 9601, *et seq.*)
5. National Oil and Hazardous Substances Pollution Contingency Plan, 40 *Code of Federal Regulations* (CFR) FR 300.
6. Memorandum of Understanding between the U.S. Department of Energy and the U.S. Army Corps of Engineers Regarding Program Administration and Execution of the Formerly Utilized Sites Remedial Action Program (FUSRAP), March 1999. Available at http://www.lm.doe.gov/documents/3_pro_doc/8_references/framework/fusrapmou.pdf
7. Institutional Controls and Transfer of Real Property under CERCLA Section 120(h)(3)(A), (B) or (C), U.S. Environmental Protection Agency, Washington, DC. Available at http://www.epa.gov/swerffrr/documents/fi-icops_106.htm.
8. DOE P 454.1, *Use of Institutional Controls*, U.S. Department of Energy, Washington, DC. Available at www.eh.doe.gov/oepa/guidance/ems/orderp454-1.pdf.
9. International City/County Management Association, Land Use Controls website, <http://www.lucs.org/>.
10. *Site Transition Framework*, DOE Office of Legacy Management, Washington, DC. Available at http://www.lm.doe.gov/documents/3_pro_doc/guidance/04_14stf.pdf.
11. *Formerly Utilized Sites Remedial Action Program (FUSRAP) USACE/DOE Transmittal Procedures*, USACE, Washington, DC, April 26, 2001 (draft).
12. U.S. Environmental Protection Agency, *Close Out Procedures for National Priorities List Sites*, Office of Emergency and Remedial Response, EPA 540-R-98-016, OSWER Directive 9320.2-09A-P, PB98-963223, January 2000.