

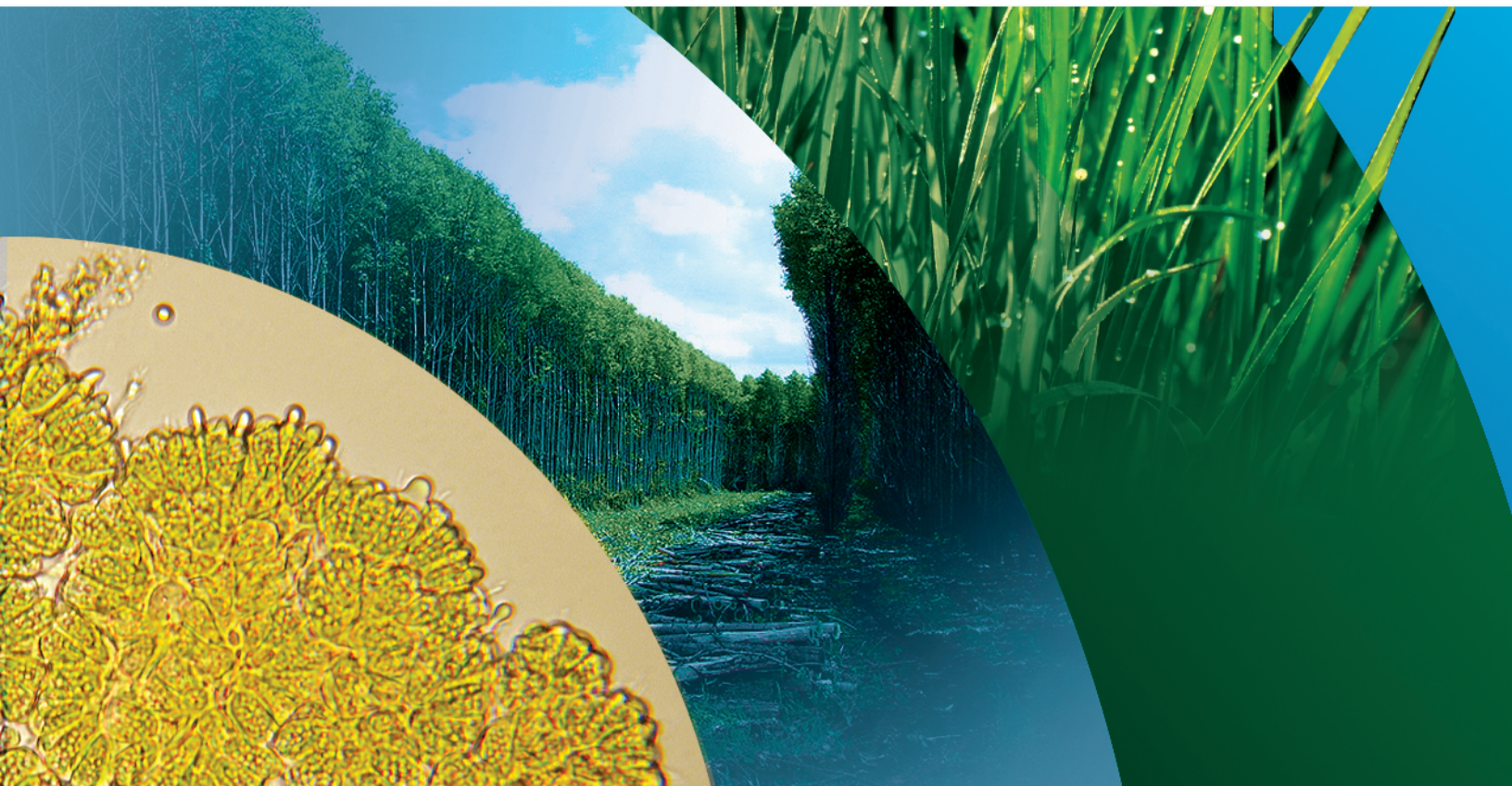

BIOENERGY TECHNOLOGIES OFFICE
Multi-Year Program Plan

November 2014



EXECUTIVE SUMMARY

The Bioenergy Technologies Office is one of the 10 technology development offices within the Office of Energy Efficiency and Renewable Energy at the U.S. Department of Energy. This Multi-Year Program Plan (MYPP) sets forth the goals and structure of the Bioenergy Technologies Office (the Office). It identifies the research, development, demonstration, and deployment (RDD&D) activities the Office will focus on over the next five years and outlines why these activities are important to meeting the energy and sustainability challenges facing the nation.

This MYPP is intended for use as an operational guide to help the Office manage and coordinate its activities, as well as a resource to help communicate its mission and goals to stakeholders and the public.

Bioenergy Technologies Office Mission and Goals

The mission of the Office is to:

Develop and transform our renewable biomass resources into commercially viable, high-performance biofuels, bioproducts, and biopower through targeted research, development, and demonstration supported through public and private partnerships.

The goal of the Office is to develop commercially viable bioenergy and bioproduct technologies to:

- *Enable sustainable, nationwide production of biofuels that are compatible with today's transportation infrastructure, can reduce greenhouse gas emissions relative to petroleum-derived fuels, and can displace a share of petroleum-derived fuels to reduce U.S. dependence on foreign oil*
- *Encourage the creation of a new domestic bioenergy and bioproduct industry.*

Technology Portfolio

The Office manages a diverse portfolio of technologies across the spectrum of applied research, development, demonstration, and deployment (RDD&D) within the dynamic context of changing budgets and administrative priorities. The Office portfolio is organized according to the biomass-to-bioenergy supply chain—from the feedstock source to the end user (see Figure A)—with major focus on feedstock supply and biomass conversion.



Figure A: Biomass-to-bioenergy supply chain

The Office has developed a coordinated framework for managing its portfolio based on systematically investigating, evaluating, and selecting the most promising opportunities across a wide range of emerging technologies and technology-readiness levels. This approach is intended to support a diverse technological portfolio in applied research and development (R&D), while identifying the most promising targets for follow-on industrial-scale demonstration, with increasing integration and complexity.

Key components of the portfolio include the following:

- R&D on sustainable, high-quality feedstock supply systems
- R&D on biomass conversion technologies
- Demonstration and validation of integrated biorefinery technologies up to industrial scale
- Cross-cutting sustainability, analysis, and strategic communications activities.

Technology Development Timeline and Key Activities

In order to achieve the Office's goals, all of the challenges and barriers identified within this MYPP need to be addressed. However, the issues identified in Figure B are critical to reaching five-year goals and will be emphasized within the Office's efforts over the next five years.

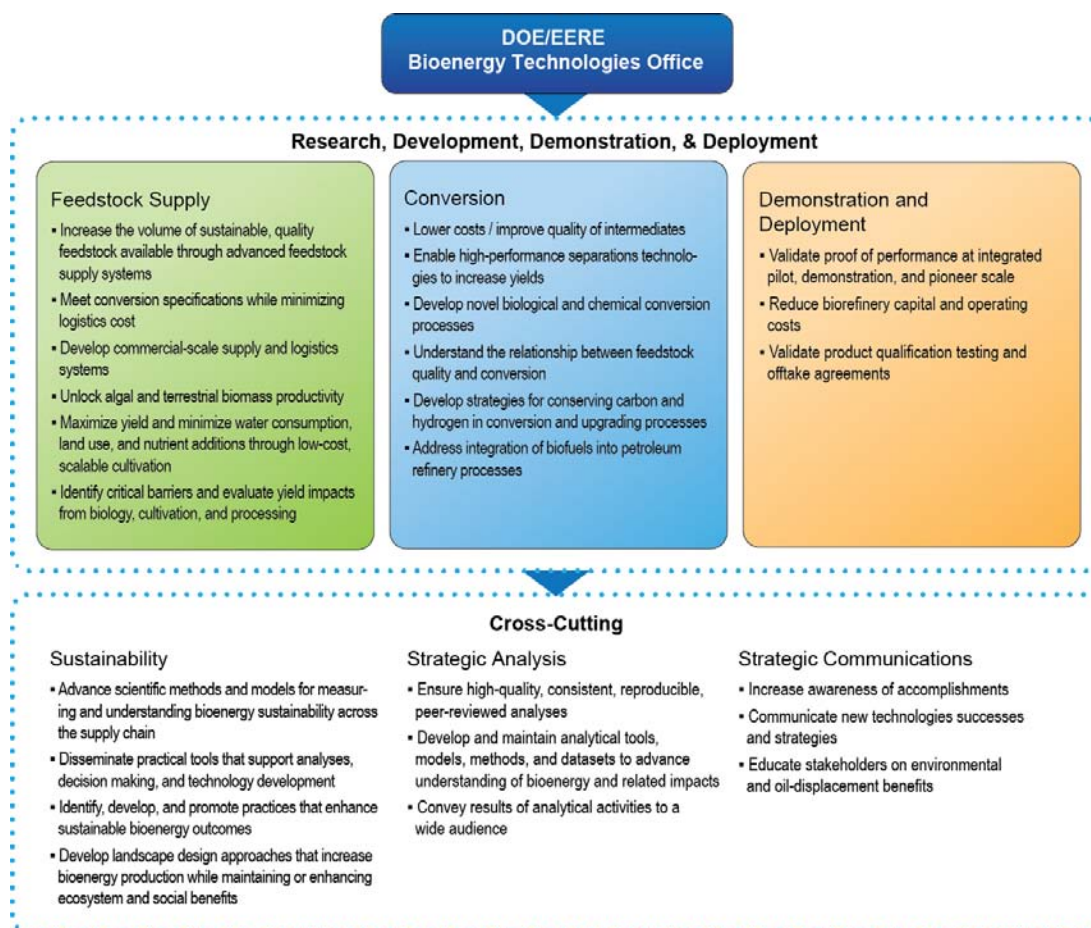

Figure B: High-impact research areas

Figure C illustrates the near-term technology development timeline and key activities of the Office. In the longer term, the Office will continue to support focused science and RD&D of advanced biomass utilization technologies. Detailed life-cycle analysis of environmental, economic, and social impacts will continue to inform decisions regarding Office activities.

This approach ensures the development of the required technological foundation, leaves room for pursuing solutions to technical barriers as they emerge, and enables demonstration activities that are critical to reduce risks and validate a robust process. This lays the groundwork for future commercial deployment, as it reduces technical risks, which enables the emerging industries to grow and attract private investment. The plan addresses important technological advances in producing biofuels, as well as in the underlying infrastructure needed to ensure that feedstocks are available and products can be distributed safely with the quality and performance demanded by end consumers.

This MYPP is designed to allow the Office to progressively enable deployment of increasing amounts of biofuels, bioproducts, and bioenergy across the nation from a widening array of feedstocks. This approach will have a significant near-term impact on offsetting petroleum consumption and facilitate the shift to renewable, sustainable bioenergy technologies in the long term, while allowing the market to determine the ultimate implementation across diverse U.S. resources.

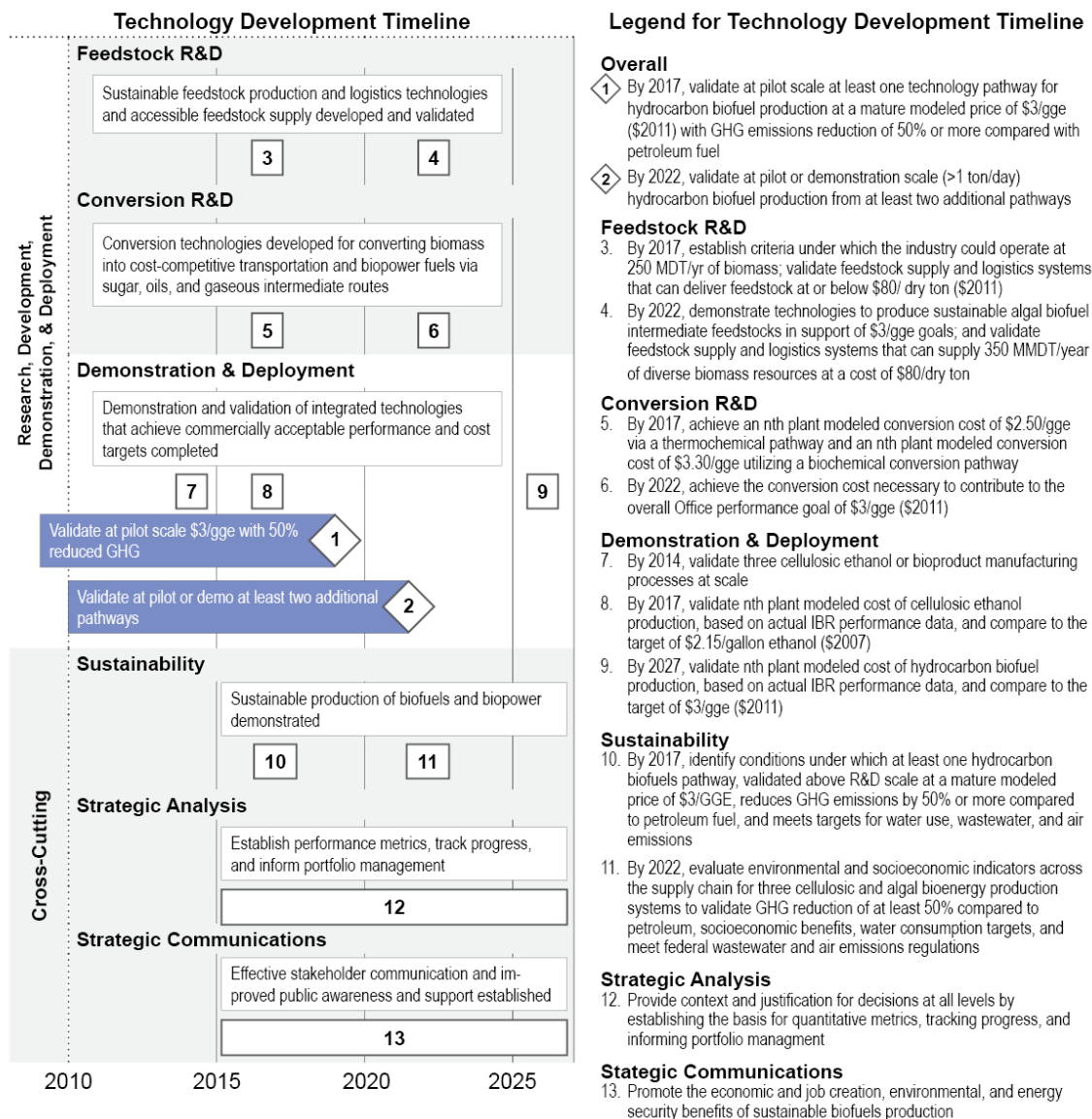

Figure C: Bioenergy Technologies Office strategy and timeline for technology development

Contents

Executive Summary.....	i
List of Abbreviations.....	viii
Section 1: Office Overview.....	1-1
1.1 Market Overview and Federal Role of the Office.....	1-5
1.1.1 Current and Potential Markets.....	1-5
1.1.2 State, Local, and International Political Climate.....	1-8
1.1.3 Other Fuel Alternatives.....	1-10
1.1.4 Market Barriers.....	1-11
1.1.5 History of Public Efforts in Biomass RDD&D.....	1-12
1.1.6 Bioenergy Technologies Office Justification.....	1-15
1.2 Office Vision and Mission.....	1-17
1.3 Office Design.....	1-19
1.3.1 Office Structure.....	1-19
1.3.2 Portfolio Logic.....	1-19
1.3.3 Relationship to Other Federal Offices.....	1-20
1.4 Office Goals and Multi-Year Targets.....	1-24
1.4.1 Office Strategic Goals.....	1-24
1.4.2 Office Performance Goals.....	1-25
1.4.3 Office Multi-Year Targets.....	1-25
Section 2: Office Technology Research, Development, Demonstration, and Deployment Plan.....	2-1
2.1 Feedstock Supply and Logistics Research and Development.....	2-7
2.1.1 Terrestrial Feedstock Supply and Logistics Research and Development.....	2-9
2.1.1.1 Terrestrial Feedstock Supply and Logistics Research and Development Support of Office Strategic Goals.....	2-14
2.1.1.2 Terrestrial Feedstock Supply and Logistics Research and Development Support of Office Performance Goals.....	2-14
2.1.1.3 Terrestrial Feedstock Supply and Logistics Research and Development Technical Challenges and Barriers.....	2-15
2.1.1.4 Terrestrial Feedstock Supply and Logistics Research and Development Approach for Overcoming Challenges and Barriers.....	2-17
2.1.1.5 Prioritizing Terrestrial Feedstock Supply and Logistics Research and Development Barriers.....	2-23
2.1.1.6 Terrestrial Feedstock Supply and Logistics Research and Development Milestones and Decision Points.....	2-29
2.1.2 Algal Feedstocks Research and Development.....	2-31
2.1.2.1 Algal Feedstocks Research and Development Support of Office Strategic Goals.....	2-35
2.1.2.2 Algal Feedstocks Research and Development Support of Office Performance Goals.....	2-35
2.1.2.3 Algal Feedstocks Research and Development Technical Challenges and Barriers.....	2-37
2.1.2.4 Algal Feedstocks Research and Development Approach for Overcoming Challenges and Barriers.....	2-39
2.1.2.5 Prioritizing Algal Feedstocks Research and Development Barriers.....	2-42
2.1.2.6 Algal Feedstocks Research and Development Milestones and Decision Points.....	2-48
2.2 Conversion Research and Development.....	2-49

2.2.1 Biochemical Conversion Research and Development.....	2-45
2.2.1.1 Biochemical Conversion Research and Development Support of Office Strategic Goals.....	2-54
2.2.1.2 Biochemical Conversion Research and Development Support of Office Performance Goals.....	2-54
2.2.1.3 Biochemical Conversion Research and Development Challenges and Barriers.....	2-55
2.2.1.4 Biochemical Conversion Research and Development Approach for Overcoming Challenges and Barriers.....	2-58
2.2.1.5 Prioritizing Biochemical Conversion Research and Development Barriers	2-64
2.2.1.6 Biochemical Conversion Research and Development Milestones and Decision Points	2-66
2.2.2 Thermochemical Conversion Research and Development.....	2-67
2.2.2.1 Thermochemical Conversion Research and Development Support of Office Strategic Goals	2-71
2.2.2.2 Thermochemical Conversion Research and Development Support of Office Performance Goals	2-72
2.2.2.3 Thermochemical Conversion Research and Development Technical Challenges and Barriers	2-73
2.2.2.4 Thermochemical Conversion Research and Development Approach for Overcoming Challenges	2-77
2.2.2.5 Prioritizing Thermochemical Conversion Research and Development Barriers.....	2-81
2.2.2.6 Thermochemical Conversion Research and Development Milestones and Decision Points	2-85
2.3 Demonstration and Deployment.....	2-86
2.3.1 Demonstration and Deployment Support of Office Strategic Goals.....	2-91
2.3.2 Demonstration and Deployment Support of Office Performance Goals.....	2-91
2.3.3 Demonstration and Deployment Challenges and Barriers	2-92
2.3.4 Demonstration and Deployment Approach for Overcoming Challenges and Barriers	2-96
2.3.5 Prioritizing Demonstration and Deployment Barriers	2-101
2.3.6 Demonstration and Deployment Milestones and Decision Points.....	2-103
2.4 Sustainability.....	2-104
2.4.1 Sustainability Support of Office Strategic Goals.....	2-107
2.4.2 Sustainability Support of Office Performance Goals.....	2-107
2.4.3 Sustainability Challenges and Barriers.....	2-108
2.4.4 Sustainability Approach for Overcoming Challenges and Barriers.....	2-109
2.4.5 Prioritizing Sustainability Barriers	2-113
2.4.6 Sustainability Milestones and Decision Points	2-115
2.5 Strategic Analysis.....	2-117
2.5.1 Strategic Analysis Support of Office Strategic Goals.....	2-118
2.5.2 Strategic Analysis Support of Office Performance Goals.....	2-118
2.5.3 Strategic Analysis Challenges and Barriers.....	2-118
2.5.4 Strategic Analysis Approach for Overcoming Challenges and Barriers.....	2-119
2.5.5 Strategic Analysis Milestones and Decision Points.....	2-122
2.6 Strategic Communications	2-125
2.6.1 Strategic Communications Support of Office Strategic Goals.....	2-126
2.6.2 Strategic Communications Support of Office Performance Goals.....	2-126
2.6.3 Strategic Communications Challenges and Barriers.....	2-127
2.6.4 Strategic Communications Approach for Overcoming Challenges and Barriers.....	2-128
Section 3: Office Portfolio Management.....	3-1
3.1 Office Portfolio Management Process.....	3-3

3.2 Performance Assessment..... 3-6

Bibliography..... Bibliography-1

Appendix A: Technology Pathway Structure..... A-1

Appendix B: Technical Projection Tables..... B-1

Appendix C: Calculation Methodology for Cost Goals..... C-1

Appendix D: 2012 Cellulosic Ethanol Success D-1

Appendix E: Matrix of Revisions E-1

List of Abbreviations

AMO – Advanced Manufacturing Office
ANL – Argonne National Laboratory
ANSI – American National Standards Institute
API – American Petroleum Institute
ARPA-E – Advanced Research Projects Agency-Energy
ARRA – American Recovery and Reinvestment Act
ASTM – American Society for Testing and Materials
BCAP – Biomass Crop Assistance Program
BIWG – Biofuels Interagency Working Group
BRDi – Biomass Research and Development Initiative
BSM – Biomass Scenario Model
CO₂ – carbon dioxide
CPS – Corporate Planning System
DOE – U.S. Department of Energy
DOD – U.S. Department of Defense
DOI – U.S. Department of the Interior
DOT – U.S. Department of Transportation
DT – dry tons
EERE – Office of Energy Efficiency and Renewable Energy
EIA – Energy Information Administration
EISA – Energy Independence and Security Act of 2007
EPA – U.S. Environmental Protection Agency
EPAct – Energy Policy Act of 2005
EU – European Union
EV – electric vehicle
FAA – Federal Aviation Administration
Farm Bill – The Agricultural Act of 2014
FCT – Fuel Cell Technologies Office
FE – Office of Fossil Energy
FEMP – Federal Energy Management Program Office
FFVs – flexible-fuel vehicles
GBEP – Global Bioenergy Partnership
GGE – gallon gasoline equivalent
GHG – greenhouse gas
GIS – Geographical Information Systems
GPRA – Government Performance and Results Act
GREET – Greenhouse Gases, Regulated Emissions, and Energy Use in Transportation
IBR – Integrated Biorefinery
IBSAL – Integrated Biomass Supply Analysis and Logistics
Infrastructure – Biofuels Distribution Infrastructure and End Use
ILUC – Indirect Land Use Change
INL – Idaho National Laboratory
IRIS – Integrated Resource and Information System
ISO – International Organization for Standardization

KDF – Knowledge Discovery Framework
LGP – DOE Loan Guarantee Programs
LUC – land-use change
MARKAL – Market Allocation
MSW – Municipal Solid Waste
MTBE – methyl tertiary butyl ether
MYPP – Multi-Year Program Plan
NAABB – National Alliance for Advanced Biofuels and Bioproducts
NABC – National Advanced Biofuels Consortium
NASA – National Aeronautics and Space Administration
NEMS – National Energy Modeling System
NIFA – USDA’s National Institute on Food and Agriculture
NIST – National Institute of Standards and Technology
NREL – National Renewable Energy Laboratory
NSF – National Science Foundation
the Office – The Bioenergy Technologies Office
ORNL – Oak Ridge National Laboratory
PBA – EERE Office of Planning, Budget, and Analysis
PMC – Project Management Center
PMP – project management plan
PNNL – Pacific Northwest National Laboratory
R&D – research and development
RDD&D – research, development, demonstration, and deployment
RFS – Renewable Fuels Standard
RLP – Resource Loaded Plan
RPS – Renewable Portfolio Standard
RSB – Roundtable on Sustainable Biomaterials
SC – Office of Science
SOT – State of Technology
SUV – sport utility vehicle
SWAT – Soil and Water Analysis Tool
TRLs – technology readiness levels
UL – Underwriters Laboratory
UN FAO – Food and Agriculture Organization of the United Nations
USDA – United States Department of Agriculture
VTO – Vehicle Technologies Office
WBS – work breakdown structure
wt% – percentage by weight

Section 1: Office Overview

Growing concerns over climate change, as well as the desire to stimulate a new bioenergy economy, the need to maintain a competitive advantage for the United States in renewable technologies, and the development of future generations of green jobs, have renewed the urgency for developing sustainable bioenergy and bioproducts. Biomass utilization for fuels, products, and power is recognized as a critical component in the nation's strategic plan to address our continued dependence on volatile supplies and prices of imported oil. U.S. dependence on imported oil exposes the country to critical disruptions in fuel supply, creates economic and social uncertainties for businesses and individuals, and exports revenues that could be invested in the U.S. economy.

Biomass utilization plays an important role in implementing the President's Climate Action Plan to reduce carbon pollution in America within the transportation sector. This plan proposes new fuel economy standards to reduce emissions and improve vehicle efficiency.¹

Biomass is the only renewable energy source that can offer a substitute for fossil-based, liquid transportation fuels in the near to mid-term. The United States could produce more than one billion tons² of sustainable biomass that can be used to produce reduced-carbon-emission fuel for cars, trucks, and jets; make chemicals; and produce renewable power to supply the grid. This can create new domestic economic opportunities and jobs in agriculture, manufacturing, and service sectors, while reducing future climate impacts.

The Energy Independence and Security Act of 2007 (EISA) sets aggressive goals to reduce the nation's dependence on fossil fuels and reduce greenhouse gas (GHG) emissions from the transportation sector by increasing the supply of renewable transportation fuels to 36 billion gallons by 2022.³

To support pursuit of these goals, the Bioenergy Technologies Office (the Office), within the Department of Energy's (DOE's) Office of Energy Efficiency and Renewable Energy (EERE), is focused on forming public-private partnerships with key stakeholders to research, develop, and demonstrate technologies to produce advanced bioenergy and bioproduct from lignocellulosic and algal biomass. The Office focuses on reducing technology risks from feedstock supply and

Biomass

Biomass is an energy resource derived from plant- and algae-based material that includes agricultural residues, forest resources, perennial grasses, woody energy crops, algae, municipal solid waste, urban wood waste, and food waste. It is unique among renewable energy resources in that it can be converted to carbon-based fuels, chemicals, or power.

¹ Executive Office of the President, *The President's Climate Action Plan*, June 2013, <http://www.whitehouse.gov/sites/default/files/image/president27sclimateactionplan.pdf>

² Robert Perlack, Bryce Stokes, et al. "U.S. Billion-Ton Update: Biomass Supply for a Bioenergy and Bioproducts Industry," Oak Ridge National Laboratory, ORNL/TM-2011/224 (2011), http://www1.eere.energy.gov/biomass/pdfs/billion_ton_update.pdf.

³ United States Congress, *Energy Independence and Security Act of 2007* (2007), Washington: Government Printing Office, <http://www.gpo.gov/fdsys/pkg/BILLS-110hr6enr/pdf/BILLS-110hr6enr.pdf>.

logistics through development of biorefinery technologies to enable industry investment in technology deployment at scale.

Scope of Effort/Framework for Success

Meeting these goals requires significant and rapid advances in the entire biomass-to-bioenergy supply chain—from the biomass source to the consumer (see Figure 1-1).

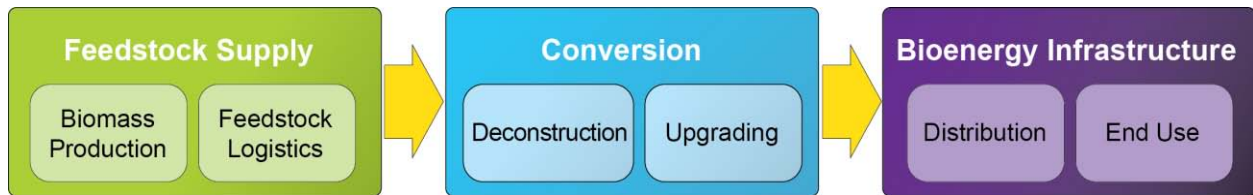

Figure 1-1: Biomass-to-bioenergy supply chain

Each element of the supply chain must be addressed to enable bioenergy and bioproducts to reach the market and ensure market acceptance. The biomass-to-bioenergy supply chain elements are as follows:

- **Feedstock Supply:** Produce large, sustainable supplies of regionally available biomass and implement cost-effective feedstock infrastructure, equipment, and systems for harvesting, collection, storage, preprocessing, and transportation
- **Bioenergy Conversion:** Develop and deploy cost-effective, integrated conversion technologies for the production of bioenergy and bioproducts
- **Bioenergy Distribution:** Implement biofuels distribution infrastructure (storage, blending, and transportation—both before and after blending and dispensing)
- **Bioenergy End Use:** Assess impact of renewable fuel blends and bioproducts on end-user applications and educate users.

This breadth of scope requires the participation of a broad range of public and private stakeholders of the evolving bioenergy sector, including the general public, the scientific/research community, trade and professional associations, environmental organizations, the investment and financial community, existing industries, and government policy and regulating organizations. These stakeholders possess valuable perspectives that can help identify the most critical challenges and better define strategies for effectively deploying bioenergy and bioproducts. The framework for success also requires extensive coordination and collaboration across multiple federal stakeholder agencies.

Bioenergy Technologies Office’s Framework for Research, Development, and Demonstration

A critical measure of the Office’s success is the development and demonstration of technologies within integrated biorefineries that can be subsequently commercially deployed and replicated. Similar to biorefineries producing ethanol from starch and producing biodiesel from oil seeds and waste oils, integrated

Biorefinery

A biorefinery is a facility that converts biomass into fuels, power, and chemical products. The biorefinery concept is analogous to a petroleum refinery, which produces multiple fuels and products from petroleum.

biorefineries are expected to produce multiple products to take advantage of the diverse biomass components and processing intermediates—maximizing the value and decreasing the waste derived from the biomass feedstock.⁴

The wide diversity of potential biomass feedstocks, conversion technologies, and product suites allows for a multitude of biorefinery integration options. Determining which technology options are closest to commercialization is based on a number of factors, including feedstock risk, technology risk, and market size. The Office actively identifies and evaluates feedstock and technology risks through analyses of data from research, development, demonstration, and deployment (RDD&D) into a broad-based set of feedstocks and conversion technologies. By applying a methodical approach to evaluating opportunities within the available feedstocks and technology options, the Office is able to prioritize RDD&D at increasing scale on high-impact technologies that were assessed to have significant impacts on nearer-term bioenergy production and will most benefit from government investment.

Specific, focused technology pathways are prioritized for development to pilot-scale validation based on techno-economic analyses, feedstock impact, and market potential. Pilot-scale validation of selected technologies provides a transparent, accessible example against which private partners can assess their own technological progress while maintaining the scientific and engineering expertise to support and validate development of emerging technologies.

This approach has several distinct advantages:

- It maintains a balanced portfolio of RDD&D to maintain earlier-stage, promising technologies for which specific pathways may not yet be adequately developed, while building a knowledge base of that technology relative to feedstock characteristics and potential.
- It ensures the Office will examine diverse feedstocks and conversion technologies for producing biofuels, bioproducts, and bioenergy.
- It effectively links resources with the stages of technology readiness, from applied research through commercial deployment.
- It leverages breakthroughs from the Office of Science (SC) and the Advanced Research Projects Agency–Energy (ARPA-E) as a means to continually repopulate the EERE RDD&D pipeline.
- It helps identify gaps within the portfolio, as well as crucial linkages across RDD&D stages.
- It is adequately flexible to accommodate new ideas and approaches, as well as various combinations of feedstocks and processes in real biorefineries.

Expanded Office Focus on Advanced Biofuels

While the Office’s overall mission is focused on developing advanced technologies for the production of fuels, products, and power from biomass, the Office’s near-term goals are focused on the conversion of biomass into liquid transportation fuels and on bioproducts and biopower

⁴ National Renewable Energy Laboratory, “What Is a Biorefinery?” (2009), <http://www.nrel.gov/biomass/biorefinery.html>.

that enable renewable fuels production. Developing reduced-carbon-emission biofuels for transportation plays an important role in plans to reduce carbon pollution. Historically, the Office's focus has been on RDD&D for ethanol production from lignocellulosic biomass. With achievement of the cellulosic ethanol cost targets, the Office has shifted toward developing other advanced biofuels that will contribute to the Renewable Fuel Standard (RFS) volumetric requirements. By focusing on these biomass-based hydrocarbon fuels (renewable gasoline, diesel, and jet fuel) and hydrocarbons from algae, the Office seeks to engage the refinery industry in developing solutions, while utilizing existing infrastructure as much as possible.

The Office has demonstrated technologies that can be scaled-up to produce modeled price-competitive cellulosic ethanol. This is the culmination of two decades of conversion technology research and development (R&D). DOE-funded R&D in this area has led to a well-developed body of work regarding the performance of ethanol as both a low-volume percentage (E10) gasoline blend in conventional vehicles and at higher blends (E85) in flexible-fuel vehicles.⁵ (See Appendix D for more information about our recent accomplishments in cellulosic ethanol.) The investments the Office has made in technologies that can reduce the recalcitrance of lignocellulosic biomass are being leveraged toward developing new advanced drop-in, hydrocarbon biofuels, bioproducts, and bioenergy that can directly replace products created from the whole barrel of oil.

⁵ U.S. Department of Energy, *Intermediate Ethanol Blends* (2013), http://www1.eere.energy.gov/vehiclesandfuels/technologies/fuels/ethanol_blends.html.

1.1 Market Overview and Federal Role of the Office

Markets for biofuels, bioproducts, and bioenergy exist today both in the United States and around the world, yet the untapped potential is enormous. Industry growth is currently constrained by high production costs, competing energy technologies, limited infrastructure, and other market barriers. Market incentives and legislative mandates focused at helping overcome some of these barriers, if maintained, can reduce uncertainty for investors.

1.1.1 Current and Potential Markets

Major end-use markets for biomass-derived products include transportation fuels, products, and power. Today, biomass is used as a feedstock in all three categories, but the contribution is small compared to oil and other fossil-based products. Most biomass-derived products are now produced in facilities dedicated to a single primary product, such as ethanol, biodiesel, plastics, paper, or power (corn wet mills are an exception). The primary feedstock sources for these facilities are conventional grains, plant oils, and wood.

To meet national goals for increased production of renewable fuels, products, and power from biomass, a more diverse feedstock resource base is required—one that includes biomass from agricultural and forest residues, as well as dedicated energy crops. Ultimately, the industry is expected to move toward large biorefineries that produce a mix of biofuels and bioproducts, with integrated, onsite cogeneration of heat and power, as well as scenarios in which the production of renewable fuels and products are integrated with existing petroleum refineries or corn ethanol plants.

Transportation Fuels: America's transportation sector relies almost exclusively on refined petroleum products, which account for more than 71% of the oil used. Oil accounts for 93% of transportation fuel use, with biofuels, natural gas, and electricity accounting for the balance.⁶ Nearly 8.1 million barrels of oil are required every day to fuel the 232 million vehicles that constitute the U.S. light-duty transportation fleet.⁷

Biomass is a direct, near-to-mid-term alternative to oil for supplying liquid transportation fuels to the nation. In the United States, nearly all gasoline is now blended with ethanol up to 10% by volume, and cars produced since the late 1970s can run on E10. In January 2011, the U.S. Environmental Protection Agency (EPA) issued partial waivers that permit the use of E15 in model-year 2001 vehicles and newer. While E15 has not yet entered the market at significant volumes, most of the remaining hurdles are at the state level. While there are alternatives to fossil-derived fuels to power light duty vehicles, diesel and jet markets have few alternatives. Diesel consumption in the United States is 54 billion gallons per year and jet fuel consumption is 22 billion gallons per year.⁸ Conversion technologies that produce renewable diesel and

⁶ U.S. Department of Energy, *Monthly Energy Review* (December 2013), Washington: Government Printing Office, DOE/EIA-0035.

⁷ U.S. Department of Energy, Oak Ridge National Laboratory, *Transportation Energy Data Book, Edition 32* (2013).

⁸ Energy Information Agency, *Annual Energy Review* (2014), <http://www.eia.gov/totalenergy/data/annual/>.

renewable jet fuel can fill the need for biomass-based alternatives for these diesel and jet markets.

High world oil prices, supportive government policies, growing environmental and energy security concerns, and the availability of low-cost corn and plant oil feedstocks have provided favorable market conditions for biofuels in recent years. Ethanol, in particular, has been buoyed by the need to replace the octane and clean-burning properties of methyl tertiary butyl ether (MTBE), which has been removed from gasoline because of groundwater contamination concerns. As shown in Figure 1-2, current domestic production capacity of ethanol has increased rapidly over the past five years—from under 8 billion gallons per year to nearly 15 billion gallons in 2013.

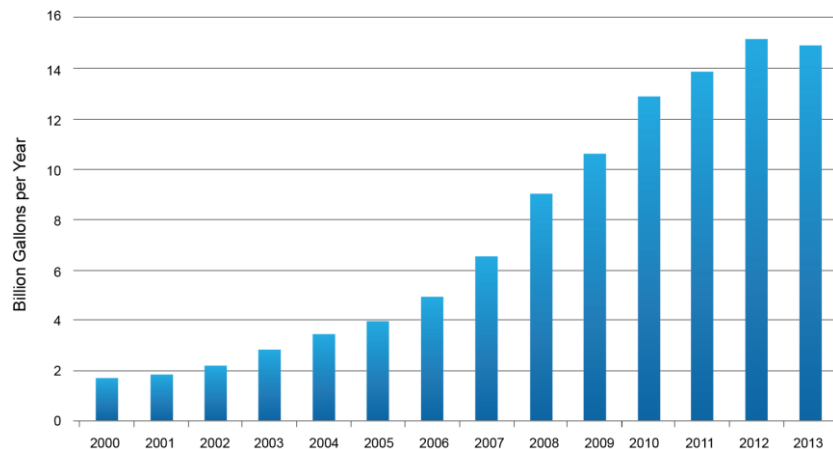

Figure 1-2: U.S. ethanol production capacity⁹

Over the last few years, commodity prices have fluctuated dramatically, creating market risks for biofuel producers and the supply chain. The national RFS legislated by EISA provides a reliable market for biofuels of 21 billion gallons of advanced biofuels by 2022. Blender tax credits for ethanol and biodiesel have historically helped to ensure that biofuels can compete with gasoline. These tax credits for conventional ethanol and biodiesel expired in January 2011, but most analysts have seen minimal impact on the conventional ethanol industry. The Cellulosic Ethanol Tax Credit was still in place and was set to expire at the end of 2013 without an extension by Congress.

To successfully penetrate the target market, however, the minimum profitable biofuel price must be low enough to compete with gasoline. A minimum profitable fuel selling price of \$3 per gallon gasoline equivalent (GGE) can compete on an energy-adjusted basis with gasoline derived from oil costing \$75–\$90 per barrel. Given the broad range of oil prices projected by the Energy Information Administration (EIA) for 2022 [\$69–\$162 per barrel],¹⁰ bioenergy technology may

⁹ Renewable Fuels Association, *Battling for the Barrel: Ethanol Industry Outlook* (2013), <http://ethanolrfa.org/page/-/PDFs/RFA%202013%20Ethanol%20Industry%20Outlook.pdf?nocdn=1>.

¹⁰ U.S. Department of Energy, *Annual Energy Outlook 2013 with Projections to 2040*, http://www.eia.gov/forecasts/archive/aeo13/source_oil_all.cfm#tightoil.

continue to require policy support and regulatory mandates in order to enable the new bioenergy sector while it is being established.

Consumer attitudes about fuel prices and performance, biofuel-capable vehicles, and the environment also affect demand for biofuels and renewable products. Consumers who are generally unfamiliar with biofuels and have been hesitant to use them, even where they are available, may shift preferences as consumer confidence in biofuel use increases and as public awareness of the positive effect of biofuels on climate change grows.¹¹

Products: Up to 7% of U.S. crude oil imports are used to make chemicals and products, such as plastics for industrial and consumer goods,¹² contributing a value added to the U.S. economy of \$255 billion. Many products derived from petrochemicals could be replaced with biomass-derived materials. Less than 4% of U.S. chemical sales are biobased.¹³ Organic chemicals such as plastics, solvents, and alcohols represent the largest and most direct market for bioproducts.¹⁴ The market for specialty chemicals is much smaller but is projected to double in 15 years¹⁵ and offers opportunities for high-value bioproducts that have higher profitability potential than the commodity fuels market. Due to this potential, bioproduct manufacturing represents a near-term market opportunity to support the development of the biorefining industry.

Some traditional fossil-based chemical companies are forming alliances with food processors and other firms to develop new chemical products that are derived from biomass, such as natural plastics, fibers, cosmetics, liquid detergents, and a natural replacement for petroleum-based antifreeze.¹⁶ These manufacturing alliances will need to demonstrate integrated production, including feedstock production and logistics through conversion, separation, purification, and market acceptance testing.

Biomass-derived products will also compete with existing starch-based bioproducts, such as poly lactic acid. For biomass-derived products to compete, they must be price competitive with these existing products and address commodity markets. New biomass-derived products will also have to compete globally and will, therefore, require efficient production processes and low production costs.

Power: Less than 2% of the oil consumed in the United States is used for electric power generation. Fossil fuels dominate U.S. power production and account for more than 67% of generation, with coal comprising 43%, natural gas 24%, and oil 1%. The balance is provided by

¹¹ National Science Foundation, *The Roadway to Partial Petroleum Replacement with Biomass-Derived Fuels—A Report Along the Way* (2010).

¹² Redefining Chemical Manufacture—Replacing Petroleum with Plant-Derived Feedstocks, John W. Frost, *Industrial Biotechnology* 2005, 1, 23-24.

¹³ Biotechnology Industry Organization, *Biobased Chemicals and Products: A New Driver for Green Jobs*, <http://www.bio.org/articles/biobased-chemicals-and-products-new-driver-green-jobs>, March 10, 2010.

¹⁴ Amory Lovins, et al, *Winning the Oil Endgame: Innovation for Profits, Jobs, and Security*, Rocky Mountain Institute (2004).

¹⁵ Biotechnology Industry Organization, *Biobased Chemicals and Products: A New Driver for Green Jobs*.

¹⁶ U.S. Department of Energy, *Top Value Added Chemicals from Biomass: Volume I—Results of Screening for Potential Candidates from Sugars and Synthesis Gas* (2004).

nuclear (21%) and renewable sources (10%), including 1%¹⁷ provided by biopower. New natural-gas-fired, combined-cycle plants are expected to increase the natural gas contribution, with coal-fired power maintaining a dominant role. Renewable energy, which includes biopower, is projected to have the largest increase in production capacity between 2012 and 2040.¹⁸

Dedicated utility-scale biopower applications are a potential route to further reduce U.S. reliance on fossil fuels and improve the sustainability associated with power generation. Limits to the availability of a reliable, sustainable feedstock supply, as well as competing demands for biofuels to meet EISA goals, may constrain the feedstock volumes available for utilization in biopower applications and may also increase feedstock costs for both applications. A near-term opportunity to increase the use of biomass for power generation, thereby reducing GHG emissions, is to increase the deployment of co-firing applications for biomass and biomass-derived intermediates in existing power-generating facilities.

1.1.2 State, Local, and International Political Climate

State and Local Political Climate

States play a critical role in developing energy policies by regulating utility rates and the permitting of energy facilities. Over the last two decades, states have collectively implemented hundreds of policies promoting the adoption of renewable energy. To encourage alternatives to petroleum in the transportation sector, states offer financial incentives for producing alternative fuels, purchasing flexible-fuel vehicles, and developing alternative fuels infrastructure. In some cases, states mandate the use of ethanol and/or biodiesel. Several states have also established renewable portfolio standards to promote the use of biomass in power generation.¹⁹

Many states encourage biomass-based industries to stimulate local economic growth—particularly in rural communities that are facing challenges related to demographic changes, job creation, capital access, infrastructure, land use, and environment. Growth in the biofuels industry creates jobs through plant construction, operation, maintenance, and support, while providing risk reduction to farmers through inter-cropping and market expansion. Several states have also recently begun to develop policies to reduce GHG emissions and are looking to biopower and biofuels applications as a means to achieve targeted reductions.

International Political Climate

Oil is expected to remain the dominant energy source for transportation worldwide through 2035, with overall oil consumption expected to increase from 87 million barrels per day in 2010 to about 115 million barrels per day in 2040.²⁰ However, the use of renewable fuels is rising. Many nations are seeking to reduce petroleum imports, boost rural economies, and improve air quality through increased use of biomass. Some countries are pursuing biofuels as a means to reduce GHG emissions. Brazil and the United States lead the world in production of biofuels for

¹⁷ U.S. Department of Energy, *Monthly Energy Review* (December 2013), Washington: Government Printing Office, DOE/EIA-0035.

¹⁸ U.S. Department of Energy, *Annual Energy Outlook 2013 with Projections to 2040*.

¹⁹ U.S. Department of Energy, *Most states have Renewable Portfolio Standards* (February 3, 2012).

²⁰ U.S. Department of Energy, *International Energy Outlook 2013* (2013), Washington: Government Printing Office, DOE/EIA-0484.

transportation, primarily ethanol (see Figure 1-3), and several other countries have developed ethanol programs, including China, India, Canada, Thailand, Argentina, Australia, and Colombia.²¹

As countries are developing policies to encourage bioenergy, many are also developing sustainability criteria for the bioenergy they produce and use within their countries. Both the United States and the European Union (EU) specify certain land-use restrictions and GHG reduction requirements for renewable fuels.²² The EU is also implementing additional biofuel sustainability criteria and reporting requirements.

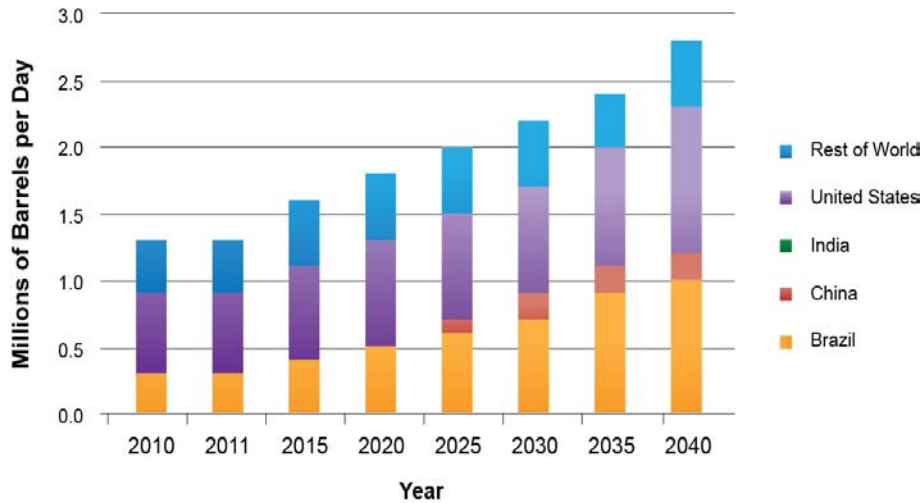

Figure 1-3: Global Production of Biofuels²³

Several international groups are developing or implementing sustainability criteria and standards to promote responsible practices across the bioenergy supply chain, from biomass production to end use. For example, the Roundtable on Sustainable Biofuels develops and maintains a global standard and certification system for organizations demonstrating compliance and commitment to sustainable and responsible practices. The International Organization for Standardization is developing criteria to advance international trade and the use of sustainable bioenergy. The Global Bioenergy Partnership facilitates information exchange, capacity building, and the adoption of voluntary sustainability criteria and indicators. These efforts, which address environmental, social, and economic aspects of bioenergy production, are building consensus among key partners on acceptable metrics and criteria to enable deployment of responsible industry practices worldwide.

The relationship among bioenergy, agriculture, and land-use change has been the subject of increasing attention, particularly with regard to the conversion of old growth forests and native prairies into agriculture production. Policymakers, eager to address this issue, have encouraged

²¹ U.S. Department of Energy Alternative Fuels Data Center, *Global Ethanol Production* (2013), <http://www.afdc.energy.gov/data/10331>.

²² <http://www.biofuelstp.eu/legislation.html>.

²³ U.S. Department of Energy, *International Energy Outlook 2013* (2013), Washington: Government Printing Office, DOE/EIA-0484.

scientists in the bioenergy field to focus on researching the indirect impacts of bioenergy production in order to understand the magnitude of the linkage, as well as to identify and protect any vulnerable areas valued for their role in preserving biodiversity and sequestering carbon.

In recent years, attention has focused on how the expanding production of bioenergy crops can influence international markets, potentially triggering price surges and price volatility for staple foods. DOE develops technologies that produce biofuels from feedstocks that have no or minimal impacts on food crops. As such, DOE R&D activities focus on developing feedstocks such as agricultural residues, forestry residues, urban wood waste/mill residues, and energy crops. Some governments have addressed this issue by discouraging the use of food-based feedstocks for bioenergy production. Over the past several years, China halted construction of new food-grain-based ethanol plants and has worked to promote policies that encourage the production of biofuels from non-food feedstocks grown on marginal land. Many countries—particularly in the developing world—have identified ways to minimize competition. Others have identified strategies for producing bioenergy from residues in conjunction with food, feed, and other products that can increase food security by generating employment, raising income in farming communities, and promoting rural development (Food and Agriculture Organization of the United Nations or UN FAO).²⁴ The EU has also enacted a variety of environmental policies that have impacted bioenergy markets in the United States. European targets for the production of 20% renewable power by 2020 have led to an expanding market for American and Canadian wood pellets and raw biomass feedstock. Proposals for EU's tax on carbon emissions in the aviation sector have helped generate interest in the market for biobased aviation fuels in the United States. Most recently, the European Parliament has moved to impose limits on the volume of conventional biofuels in the EU market, while potentially increasing incentives for the production of cellulosic and other advanced biofuels.

1.1.3 Other Fuel Alternatives

The principal technologies that compete with biomass today rely on continued use of fossil energy sources to produce transportation fuels, products, and power in conventional petroleum refineries, petrochemical plants, and power plants. In the future, as oil demand and prices continue to rise, several non-traditional technologies will likely meet some of the transportation fuel needs of the United States. Those technologies include the following.

- **Hydrogen:** Hydrogen can be produced via multiple routes, including water electrolysis, algae, reforming renewable liquids or natural gas, coal gasification, or nuclear synthesis.
- **High-Carbon Intensity Fuels:** Less mature alternate fuel technologies against which biofuels should be compared include high-carbon intensity fuels such as oil-shale-derived and tar-sands-derived fuels. Oil shale is a rock formation that contains large concentrations of combustible organic matter called kerogen and can yield significant quantities of shale oil. Various methods of processing oil shale to remove the oil have

²⁴ “Bioenergy and Food Security,” Food and Agriculture Organization of the United Nations, <http://www.fao.org/bioenergy/foodsecurity/befs/en/>.

been developed.²⁵ Tar sands (also called oil sands) contain bitumen or other highly viscous forms of petroleum, which are not recoverable by conventional means. The petroleum is obtained either as raw bitumen or as a synthetic crude oil. The United States has significant tar sands resources—about 58.1 billion barrels.²⁶

- **Gas-to-Liquids:** The advent of hydraulic fracturing and horizontal drilling technologies has enabled increased production of natural gas in the United States. Natural gas can be converted to liquid transportation fuels (diesel, jet, and gasoline) and chemicals by steam-methane reforming reactions and Fischer-Tropsch conversion processes; these are technologies that are different from those used with crude oil.
- **Coal-to-Liquids:** In terms of cost, coal-derived liquid fuels have traditionally been non-competitive with fuels derived from crude oil. As oil prices rise, however, coal-derived transportation fuels may become competitive. While conventional coal-to-liquid technologies can often be adapted to use biomass as a feedstock, both in standalone applications or blended with coal, the biomass resource does not scale as well as coal.
- **Electricity:** Electricity can be used to power electric vehicles. Electric vehicles store electricity in an energy storage device, such as a battery, or produce on-board power via a fuel cell, powering the vehicle's wheels via an electric motor. Plug-in hybrid electric vehicles combine the benefits of pure electric vehicles and hybrid electric vehicles.

1.1.4 Market Barriers

Biorefineries using cellulosic and algal biomass as a feedstock face market barriers at the federal, state, and local levels. Feedstock availability, production costs, investment risks, consumer awareness and acceptance, and infrastructure limitations pose significant challenges for the emerging bioenergy industry. Widespread deployment of integrated biorefineries will require demonstration of cost-effective biorefinery systems and sustainable, cost-effective feedstock supply infrastructure. The following market barriers are also discussed in Section 2:

Ft-A Feedstock Availability and Cost

Im-A Inadequate Supply Chain Infrastructure

Im-B Agricultural Sector-Wide Paradigm Shift

Im-C High Risk of Large Capital Investments

Im-D. Lack of Industry Standards and Regulations

Im-E Cost of Production

Im-F Offtake Agreements

Im-G Uncertain Pace of Biofuel Availability

Im-H Availability of Biofuels Distribution Infrastructure

Im-I Lack of Acceptance and Awareness of Biofuels as a Viable Alternative

It-A End-to-End Process Integration

It-C Technical Risk of Scaling and Fully Integrating Biomass Conversion Technologies.

²⁵ U. S. Congress, Senate Energy and Natural Resources Committee. *Oversight Hearing on Oil Shale Development Efforts*. 109th Congress, 1st session. (April 12, 2005)

²⁶World Energy Council, “Survey of Energy Resources” (2010), http://www.worldenergy.org/documents/ser_2010_report_1.pdf.

The following additional barriers cross the entire supply chain and so are not specific to any particular technology area.

- **Mm-A: Lack of Understanding of Environmental/Energy Tradeoffs.** There is a need for a more thorough, systematic evaluation of the impact of expanded biofuels production on the environment and food supply for humans and animals. Sufficient data needs to be generated from various operational facilities' designs to provide valid sustainability benchmarks for the nascent industry. Analytical tools are needed to facilitate consistent evaluation of energy benefits and GHG emissions impacts of all potential advanced biofuel feedstock and conversion processes. EISA requires that all biofuels be evaluated for their reduction in GHG emissions in order to qualify under the RFS. Cellulosic biofuels, a subset of "advanced biofuels," must achieve at least a 60% reduction in GHG emissions, relative to a 2005 baseline of the petroleum displaced, including indirect land-use change. Advanced biofuels must achieve at least a 50% reduction in GHG emissions. The EPA has established the methodology for evaluating these impacts for some pathways.
- **Mm-B: Inconsistent or Competing Policies and Drivers to Facilitate Multi-Sector Shifts.** Expanding biofuels production to meet federal goals will require managing and responding to different markets and policy drivers and considerable federal, state, and local investments. Proper alignment and careful choice of policy tools across several different sectors is crucial. Legislation may ultimately determine the future portfolio mix for bioenergy production and use.
- **Mt-A: Optimization of Supply Chain Interfaces and Cross-System Integration.** The commercialization of biofuels technology will involve industrial-scale technology deployment across a dispersed supply chain. This will require integration and optimization of technologies within and across agricultural, forestry, equipment manufacturing, and biorefinery sectors to address cross-system risks and leverage cross-system positive synergies. Integrating information across sector interfaces will be critical to harnessing efficiencies and driving down costs.

1.1.5 History of Public Efforts in Biomass RDD&D

Efforts in bioenergy were initiated by the National Science Foundation and subsequently transferred to DOE in the late 1970s. Early projects focused on biofuels and biomass energy systems. In 2002, the Bioenergy Technologies Office was formed to consolidate the biofuels, bioproducts, and biopower research efforts across EERE into one comprehensive Office. From the 1970s to the present, DOE has invested more than \$4 billion [including more than \$900 million in American Recovery and Reinvestment Act of 2009 (ARRA) funds] in a variety of RDD&D programs covering biofuels, biopower, feedstocks, municipal wastes, and a variety of biobased products. Considerable progress has been made in many areas, including the Office's R&D-scale validation of technologies capable of producing modeled price-competitive cellulosic ethanol. However, continued federal support is needed to fully commercialize ethanol, other hydrocarbon fuels, and other advanced biomass technologies. Key policy shifts, major new legislation, and EERE funding levels are shown in Figure 1-4.

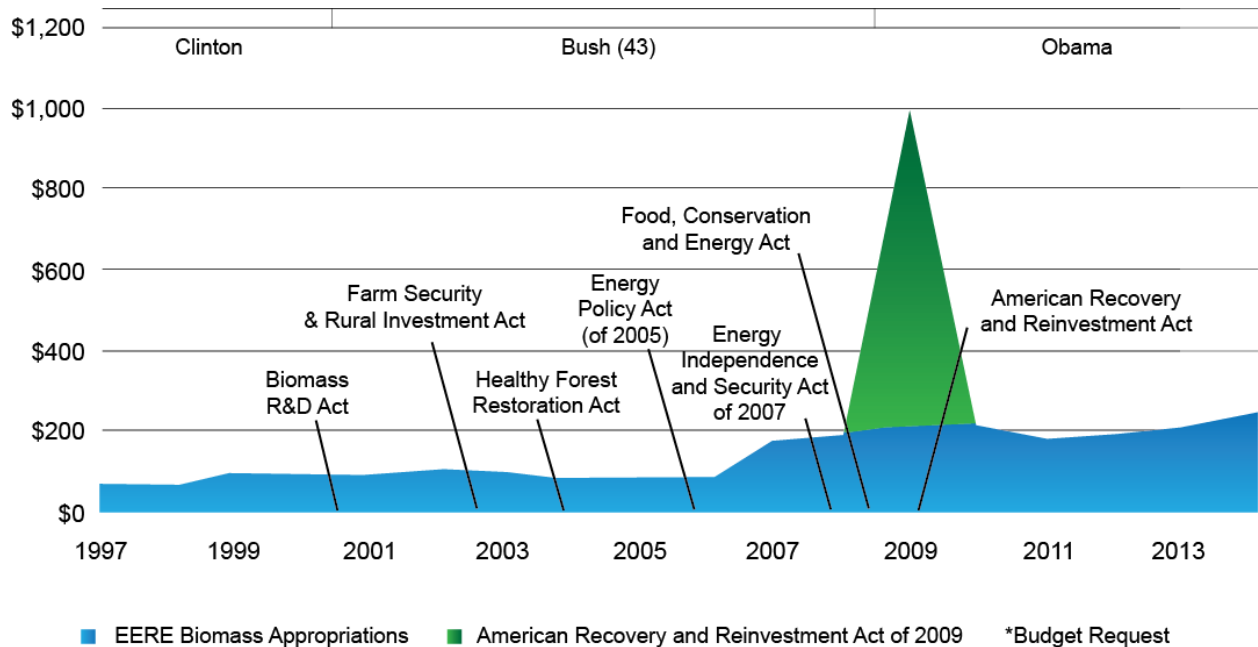

Figure 1-4: DOE EERE funding for biomass RDD&D

Especially in recent years, several legislative, regulatory, and policy efforts have increased and accelerated biomass-related RDD&D. These efforts are summarized in Table 1-1.

Table 1-1: Legislative, Regulatory, and Policy Efforts

June 2013	President's Climate Action Plan	<ul style="list-style-type: none"> • Set goals to reduce carbon pollution in America by 17% by 2020 from 2005 levels. • Outlined a strategy that focuses in part on Building a 21st Century Transportation Sector and Developing and Deploying Advanced Transportation Technologies. • Promoted partnerships between the private and public sectors to deploy cleaner fuels.
March 2011	Blueprint for a Secure Energy Future	<ul style="list-style-type: none"> • Outlined a comprehensive energy policy to cut U.S. oil imports by one-third by 2025 by reducing the nation's dependence on oil with cleaner alternative fuels and greater efficiency. • Promoted collaboration with international partners to increase bioenergy production. • Included research and incentives to reduce barriers to increased biofuels use and the commercialization of new technologies.
June 2011	A USDA Regional Roadmap to Meeting the Biofuels Goals of the Renewable Fuels Standard by 2022	<ul style="list-style-type: none"> • Developed a comprehensive regional strategy targeting barriers to the development of a successful biofuels market that will achieve, or surpass, the current U.S. Renewable Fuels Standard.
May 2009	Presidential Memorandum on Biofuels	<ul style="list-style-type: none"> • Established a Biofuels Interagency Working Group to consider policy actions to accelerate and increase biofuels production, deployment, and use. The group is co-chaired by the Secretaries of the U.S. Departments of Energy and Agriculture and the Administrator of the Environmental Protection Agency.
February 2009	American Recovery and Reinvestment Act of 2009	<ul style="list-style-type: none"> • Provided funds for grants to accelerate the commercialization of advanced biofuels R&D and pilot-, demonstration-, and commercial-scale integrated biorefinery projects. • Provided funds to other DOE programs for applied R&D, innovative research, tax credits, and other projects.
May 2008	The Food, Conservation, and Energy Act of 2008 (Farm Bill)	<ul style="list-style-type: none"> • Provided grants, loans, and loan guarantees for developing and building demonstration- and commercial-scale biorefineries. • Established a \$1.01 per gallon producer tax credit for cellulosic biofuels. • Established the Biomass Crop Assistance Program to support the production of biomass crops. • Provided support for continuation of the Biomass R&D Initiative, the Biomass R&D Board, and the Biomass R&D Technical Advisory Committee.
December 2007	Energy Independence and Security Act of 2007	<ul style="list-style-type: none"> • Supported the continued development and use of biofuels, including a significantly expanded Renewable Fuels Standard, requiring 36 billion gallons per year of renewable fuels by 2022, with annual requirements for advanced biofuels, cellulosic biofuels, and biobased diesel.
August 2005	Energy Policy Act of 2005	<ul style="list-style-type: none"> • Renewed and strengthened federal policies fostering ethanol production, including incentives for the production and purchase of biobased products; these diverse incentives range from authorization for demonstrations to tax credits and loan guarantees.

1.1.6 Bioenergy Technologies Office Justification

As the United States continues to experience the highs and lows of a volatile transportation energy market driven by fossil fuels, the need to find stabilizing solutions becomes increasingly important. The benefits of biofuels, bioproducts, and biopower include greater economic security, as significant amounts of sustainable, domestically produced feedstocks are directed to the production of renewable energy. The environmental and social benefits of biofuels, bioproducts, and biopower include a reduction in GHG emissions that lead to global warming and increased economic activity across the entire supply chain. From new jobs in the farms and forests of rural America to growing U.S. construction and manufacturing jobs in the production of bioenergy, biochemical, and vehicles, reinvesting in new U.S. technologies maintains the vital national competitive advantage and enables jobs in the renewable energy sector for future generations.

Pursuing smaller early adoption markets such as renewable aviation fuel can enable critical learning along the supply chain, de-risk technology and processes, and increase the probability of success in larger on-road fuel markets.

From 2012 to 2040, U.S. energy consumption is projected to rise by about 12%, while domestic energy production will rise by 29%.²⁷ Renewable liquid fuels, including biofuels, are projected to have the largest increase in meeting domestic consumption—growing from 8% in 2010 to more than 14% of liquid fuels in 2035.²⁸ This decreased reliance on imported energy improves our national security, economic health, and future global competitiveness and revitalizes investment and cash flows in the United States, which is vital for a growing economy.

The U.S. transportation sector is responsible for one-third of U.S. carbon dioxide (CO₂) emissions, the principal GHG contributing to climate change. Increased use of biofuels, bioproducts, and biopower can decrease life-cycle emissions of GHG and other pollutants substantially, depending on feedstock type, crop management practices, and processing. For liquid transportation fuels, biofuels are one important option for achieving such reductions, especially for diesel trucks and jet aircraft. Liquid hydrocarbon transportation fuels made from biomass are advantageous because they are largely compatible with existing infrastructure to deliver, blend, and dispense fuels.

This resulting supply of domestically produced biofuels, intended to replace petroleum imported for the chemical and fuels industry, will also retain the full U.S. investment and help reduce price volatility. This point is underscored by the Defense Department's effort to increase national energy security through energy independence, beginning with reducing U.S. exposure to volatile global oil markets. Price spikes in these markets can have profound effects on total fuel costs for the U.S. armed services.

Despite the economic, environmental, and social benefits of bioenergy production, there are significant challenges keeping the industry from its full potential. The primary challenges of sustainable feedstock supply and logistics, cost and technical risk reduction in conversion

²⁷ U.S. Department of Energy, *Annual Energy Outlook 2014 with Projections to 2040*.

²⁸ U.S. Department of Energy, *Annual Energy Outlook 2012 with Projections to 2035*.

processes, and integrated performance validation at large-scale operation need to be addressed to demonstrate robust processes that are ready for commercialization and replication by industry.

There is a unique federal role in partnering with leading R&D entities and industrial technologists across the entire bioenergy supply chain. From the development of sustainability standards and the logistics to reliably produce and deliver up to one billion tons of biomass to biorefineries, the federal government enables the teaming of experts to develop robust and selective conversion technologies and demonstrate the reduction of technical risk.

The Office is uniquely positioned to leverage its legislative authority for financial assistance and leverage DOE's successful track record in commercialization to assist developers in de-risking technologies through validated proof of performance at the pilot, demonstration, and pioneer scales. Obtaining traditional financing is a challenge for new innovative bioenergy technologies, and most pioneer facilities require equity financing of \$200 million or more. Two recent industry studies have highlighted the necessary government role in supporting this industry, showing that 86% of the large-scale biorefinery projects in the United States have been at least partially funded by DOE.²⁹ The Office support for validation of these new technologies at large scale helps to overcome these financing barriers both through direct financial assistance and de-risking the technology through proof-of-performance testing.

The overarching federal role is to ensure the availability of a reliable, affordable, and environmentally sound domestic energy supply. Billions of dollars have been spent over the last century to construct the nation's energy infrastructure for fossil fuels.³⁰ The production of alternative transportation fuels from new primary energy supplies, like biomass, is no small undertaking. The role of federal programs is to invest in the high-impact, high-value bioenergy technology RDD&D that is critical to the nation's future that industry would be unable to pursue independently. States, associations, and industry will be key participants in deploying biomass technologies once risk reductions have been sufficiently demonstrated by federal programs.

²⁹ Bacovsky, Ludwiczek, Ognissanto, Wörgetter. Status of Advanced Biofuels Demonstration Facilities, IEA Task 39-P1b, (March 2013), http://demoplants.bioenergy2020.eu/files/Demoplants_Report_Final.pdf.

³⁰ U.S. Energy Information Agency, *Direct Federal Financial Interventions and Subsidies in Energy in Fiscal Year 2010*, (July 2011), <http://www.eia.gov/analysis/requests/subsidy/pdf/subsidy.pdf>.

1.2 Office Vision and Mission

EISA aimed to increase the supply of alternative fuels and set a mandatory RFS, requiring transportation fuels that are sold in the United States to contain a minimum of 36 billion gallons of renewable fuels, including advanced and cellulosic biofuels and biomass-based diesel, by 2022. DOE has set a goal in its Strategic Plan to promote energy security through a diverse energy supply that is reliable, clean, and affordable.

To meet both EISA and DOE goals, the Office is focused on developing and demonstrating bioenergy and bioproducts technologies in partnership with other government agencies, industry, and academia. The Office supports four key tenets of the EERE Strategic Plan (which is currently being updated):

- Reduce carbon emissions from energy production and consumption
- Reduce dependence on foreign oil
- Promote the use of diverse, domestically produced, and sustainable energy resources
- Establish a domestic and globally competitive bioenergy industry.

The Office's vision, mission, and goals are shown in Figure 1-5.

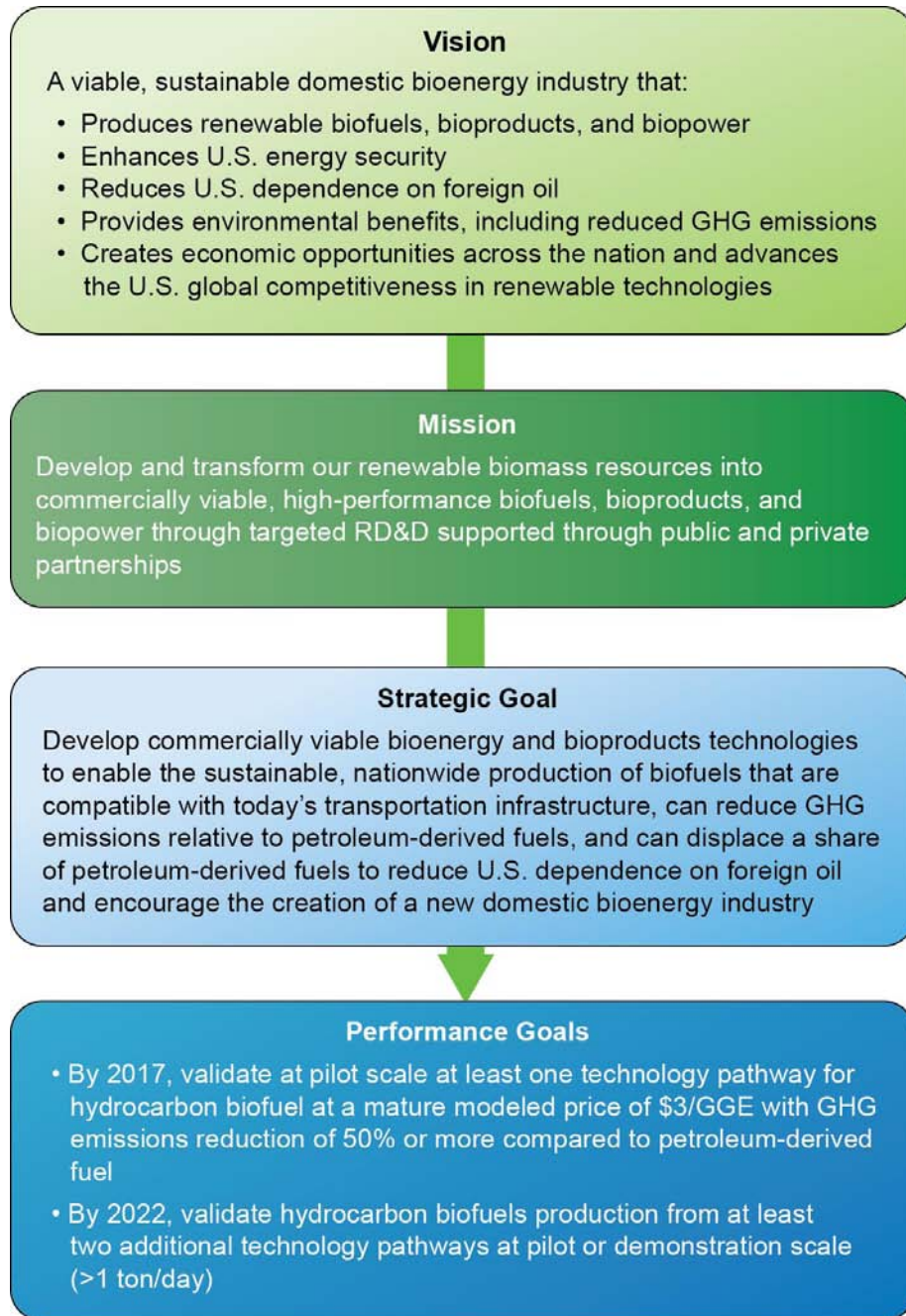

Figure 1-5: Strategic framework for the Bioenergy Technologies Office³¹

³¹ Methodology for developing performance goals is detailed in Appendix C.

1.3 Office Design

1.3.1 Office Structure

As shown in Figure 1-6, the Bioenergy Technologies Office administration and work breakdown structure is organized around two broad categories of effort: RDD&D and Cross-Cutting Activities. The first category is comprised of three technical elements: Feedstock R&D, Conversion R&D, and Demonstration and Deployment. Cross-Cutting activities include Sustainability, Strategic Analysis, and Strategic Communications.

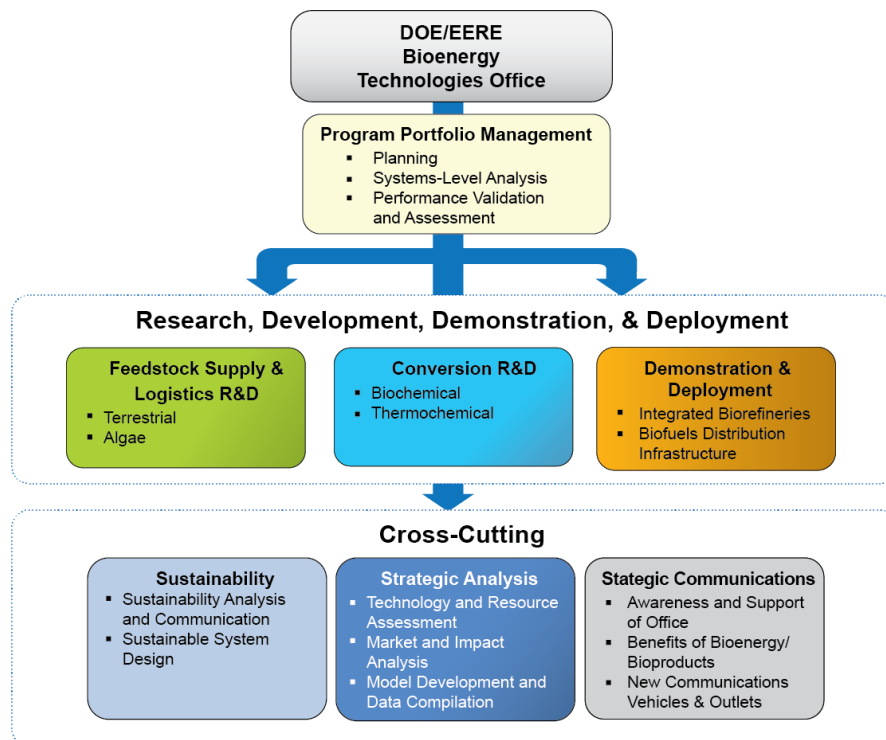

Figure 1-6: Elements of the Bioenergy Technologies Office

This approach provides for the development of precommercial, enabling technologies, as well as the integration and demonstration activities critical to proof of performance at increased scale and integration. It also accommodates the Sustainability, Analytical, and Strategic Communications activities needed to help the nation overcome market barriers and accelerate technology deployment.

The organization, activities, targets, and challenges of each of the Office’s three technical elements and three cross-cutting elements are described in detail in Section 2.

1.3.2 Portfolio Logic

The portfolio logic diagram shown in Figure 1-7 identifies inputs that guide the Office strategy and external factors that require continuous monitoring to determine the need for any programmatic adjustments. The diagram shows portfolio activities and their outputs, leading to

outcomes that support the Office mission and vision. This progression of linkages supports the framework for the Office strategy and this Multi-Year Program Plan.

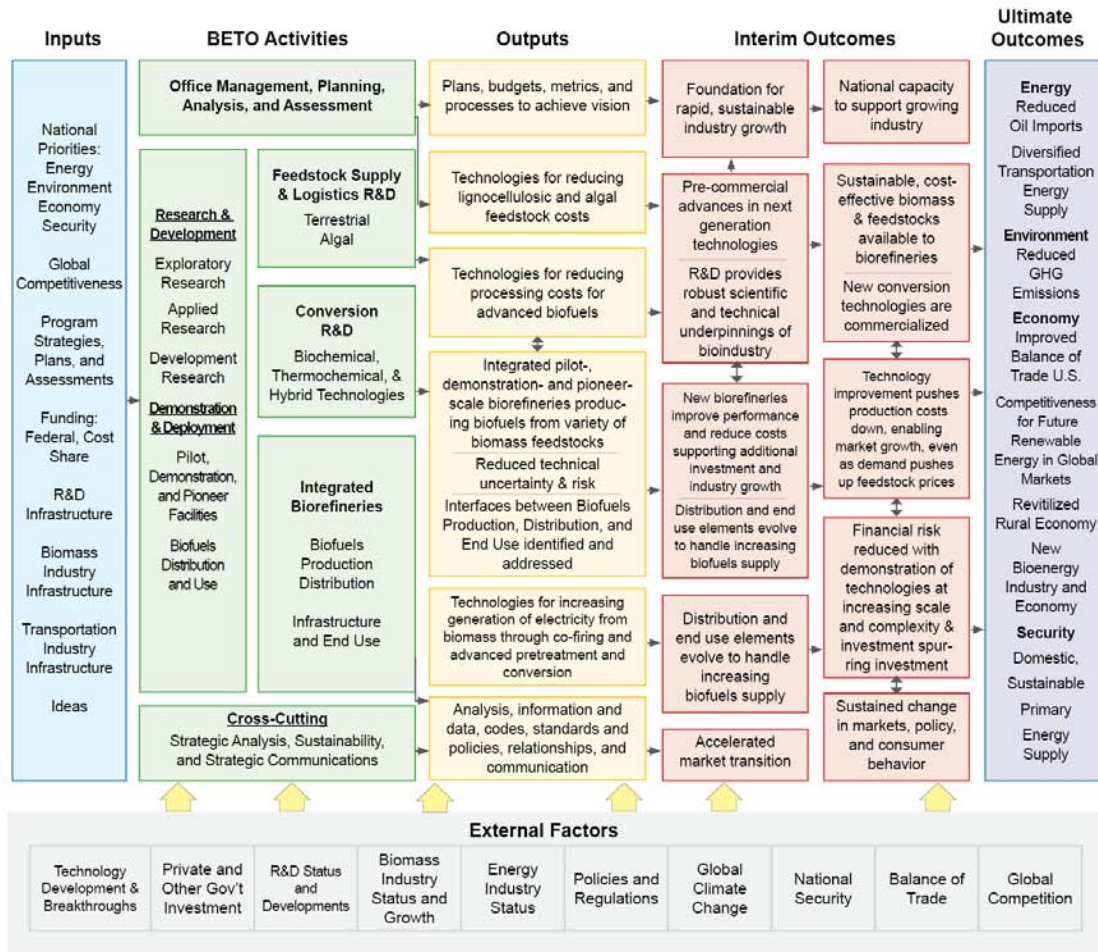

Figure 1-7: Bioenergy Technologies Office portfolio logic diagram

1.3.3 Relationship to Other Federal Offices

Coordination with other government offices involved in bioenergy development is essential to avoid duplication, leverage limited resources, optimize the federal investment, ensure a consistent message to stakeholders, and meet national energy goals. As shown in Table 1-3, the Office coordinates with several other federal agencies through a range of informal and formal mechanisms. In particular, through the Biomass Research and Development Act of 2000, the Biomass R&D Board (Board) was created. The Board—whose members meet quarterly to discuss updates and implementation strategies across federal agencies in biofuels, bioproducts, and biopower R&D—is an interagency collaboration that is co-chaired by the U.S. Department of Agriculture and DOE. The purpose of the Board is to maximize federal efforts to enhance the emerging biomass industry. Other Board partners include the Departments of Interior, Transportation, and Defense; the EPA; the National Science Foundation; and the Office of Science and Technology Policy.

Table 1-2: Summary of Federal Agency Roles across the Biomass-to-Bioenergy Supply Chain

Federal Agency	Feedstock Production	Feedstock Logistics	Biomass Conversion	Demonstration and Deployment	Biofuels Distribution	Biofuels End Use
Department of Energy	Plant and algal science; genetics and breeding; feedstock resource assessment; sustainable land, crop, and forestry management; algal feedstock cultivation and production systems	Sustainable logistics systems, including harvesting, handling, storage, and preprocessing systems; testing logistics systems at demonstration scale	Biochemical conversion (pretreatment/enzyme cost reductions); recalcitrance of all biomass resources; thermochemical conversion increase yield of hydrocarbons to fuel blendstocks and energy (gasification and pyrolysis)	Cost-shared projects and/or loan guarantees to biorefineries to demonstrate and deploy integrated conversion processes at pilot, demonstration, and pioneer scale	Flexible, compatible, sustainable, and cost-effective biofuels transportation/distribution systems development; material compatibility; alternative fuel dispensing infrastructure	Engine compatibility and optimization; vehicle emissions testing; bioproduct testing for market acceptance; education to improve awareness regarding positive impacts of biofuels
Department of Agriculture	Sustainable land, crop, and forestry management; plant science; genetics and breeding; planting/establishment payments to biomass crop producers	Sustainable harvesting of biomass crop and forest residue removal; equipment systems related to planting	Biochemical conversion (pretreatment/enzyme cost reductions); recalcitrance of forest resources; thermochemical conversion to fuels and power; on-farm biofuels systems	Loan guarantees to viable pioneer-scale facilities and grants to demonstration-scale facilities; payments to existing biorefineries to retrofit power sources to be renewable; producers to support and expand production of advanced biofuels refined from sources other than cornstarch	Loan guarantees and grants to support (1) safe and sustainable biofuel transportation/distribution; (2) refineries and blending facilities development; (3) flex-fuel pumps installation; and (4) financing of transportation/distribution industry/businesses	Market awareness and education for end users on advantages of increased biofuels use
Environmental Protection Agency	Effects of feedstock production systems, including effects on ecosystem services (water quality, quantity, biodiversity, etc.); assessment of bioenergy crop impacts		Biowaste-to-energy; characterization of air, water, and waste emissions; regulations/permitting; TSCA review of inter-generic genetically engineered microbes used for biomass conversion; testing protocols and performance verification	Health/environmental impacts of biofuels supply chain life cycle; characterization of air, water, and waste emissions; regulations/permitting; policy and research on waste-to-energy; testing protocols and performance verification; market impact of biofuels production	Permitting, air emission characterization; regulation of underground storage tanks; emergency management and remediation of biofuel spills	Engine optimization/certification; characterization of vehicle emissions and air quality, environmental, and public health impacts; regulation of air emissions; market awareness/ impact of biofuels on public health, ambient air, and vehicles
Department of Commerce/ National Institute for Standards and Technology			Catalyst design, biocatalytic processing, biomass characterization, and standardization; standards development, measurement, and modeling		Materials reliability for storage containers, pipelines, and fuel delivery systems	Standard reference materials, data, and specifications for biofuels
Department of Transportation/		Feedstock transport infrastructure development			Safe, adequate, cost-effective biofuels transportation/distribution systems development	Promotion of safe and efficient transportation while improving safety, economic competitiveness, and environmental sustainability
Federal Aviation Administration			Techno-economic analysis of processes that convert biomass to jet fuel	Builds relationships, share and collect data, identify resources, and direct research, development and deployment of alternative jet fuels by supporting Commercial Aviation Alternative Fuels Initiative	Safe, adequate, compatible, cost-effective biofuels transportation / distribution system.	Working toward certification of bio-derived jet fuels in coordination with the American Society for Testing and Materials with entire aviation supply chain

Bioenergy Technologies Office Overview

Federal Agency	Feedstock Production	Feedstock Logistics	Biomass Conversion	Demonstration and Deployment	Biofuels Distribution	Biofuels End Use
National Science Foundation	Plant genetics, algal science, and other paths to improve biofuels feedstocks and wastes as energy sources	Basic research on modifications or processes to improve feedstock preprocessing	Basic and applied research on catalysts, processes, characterization for biochemical and thermochemical conversion technologies; life-cycle analysis; environmental impact amelioration	Supportive R&D on health/environmental impacts of biofuels and bioproducts		Supportive R&D on health/environmental/safety/social issues of biofuels use
Department of the Interior	Forest management	Forest management / fire prevention (recovery of forest thinnings)	Biorefinery permitting on Department of Interior managed lands			
Department of Defense	Basic R&D on feedstock processing (municipal solid waste/waste biomass)		Solid waste gasification; applied algal and cellulosic feedstock conversion R&D; Partner in DPA	Through Defense Production Act, support biorefineries, to demonstrate and deploy integrated conversion at commercial scale	Safe, compatible, cost-effective biofuels transportation / distribution systems developed for military use	Biofuels testing; standard reference materials, data, and specifications for biofuels; biofuel use in military vehicles/crafts

Coordination among DOE Programs and Offices

Office of Science (SC): The Bioenergy Technologies Office regularly coordinates with SC, a Biomass R&D Board partner, on fundamental and applied biomass and biofuel research activities and to share information about new partnerships, major research efforts, conversion- and feedstock-related activities and user facilities, and possible joint funding requests. SC and EERE jointly developed the 2005 research roadmap, *Breaking the Biological Barriers to Cellulosic Ethanol: A Joint Research Agenda*, which outlines the basic science and applied research needed to accelerate advances in cellulosic ethanol and has helped guide multi-year technical planning.

Advanced Research Projects Agency-Energy (ARPA-E): The Office coordinates with ARPA-E by sharing information on relevant biomass-related projects—in particular those from ARPA-E’s Plants Engineered to Replace Oil (PETRO) and Electrofuels Programs.

Office of Fossil Energy (FE): The Office is working with FE to examine how to develop technology improvements to increase the efficiency, environmental performance, and economic viability of utility-scale biopower applications and how biomass and natural gas might be utilized synergistically to maximize outputs.

Office of Energy Efficiency and Renewable Energy: The following EERE offices also contribute to many aspects of biomass utilization and bioenergy technology development:

- **Fuel Cell Technologies Office (FCTO):** The production of hydrogen from biomass is pursued through two main pathways—distributed reforming of biomass-derived liquids and biomass gasification. Research efforts on reformation and gasification, the availability of biomass, and renewable hydrogen as an enabler for biofuel production are coordinated between FCTO and the Bioenergy Technologies Office. In addition, the offices collaborate on using algae to produce biofuels and hydrogen.
- **Vehicle Technologies Office (VTO):** Research on the use of non-petroleum-derived fuels, particularly ethanol and diesel replacements, is coordinated with VTO. This coordination focuses on product distribution infrastructure and end use, specifically fuel characterization and combustion testing for new biofuels and biofuel blends. The Office also interfaces with VTO’s Clean Cities Program, which develops public/private partnerships to promote alternative fuels, vehicles, and infrastructure.
- **Advanced Manufacturing Office (AMO):** Biomass-based technologies for gasification and the production of biomass-based fuels, chemicals, materials, heat, and electricity are of interest to AMO’s distributed energy, chemicals, and forest products subprograms. AMO and the Bioenergy Technologies Office are collaborating on renewable chemical precursors to polyacrylonitrile, which can be utilized for the manufacture of carbon fiber.
- **Federal Energy Management Program Office (FEMP):** FEMP works with the federal fleet to increase the use of biopower, renewable and alternative fuels, and flexible-fuel vehicles.
- **EERE Office of Strategic Programs:** Bioenergy Technologies Office efforts are supportive of, and coordinated with, broader corporate efforts, such as communications and outreach, strategic analysis, international partnerships, and legislative affairs.
- **EERE Office of Budget, Office of Business Operations:** Program analysis activities support these offices in carrying out EERE cross-cutting corporate analysis.

DOE Loan Guarantee Programs (LGP): The Office is actively engaged with LGP to support construction financing for first-of-a-kind IBR facilities. LGP provides loans and loan guarantees to a range of projects to spur further investments in advanced clean energy technologies through the reduction of technical risk in pioneering technologies.

1.4 Office Goals and Multi-Year Targets

This subsection describes the Office’s goals and targets.

1.4.1 Office Strategic Goals

As stated in Section 1.2, the Office’s overarching strategic goal is to *develop commercially viable bioenergy and bioproduct technologies to enable the sustainable, nationwide production of biofuels that are compatible with today’s transportation infrastructure, can reduce greenhouse gas emissions relative to petroleum-derived fuels, and can displace a share of petroleum-derived fuels to reduce U.S. dependence on foreign oil and encourage the creation of a new domestic bioenergy industry.*

The Office’s high-level schedule aims for development of commercially viable renewable gasoline, diesel, and jet technologies by 2017 through R&D, and enables a trajectory toward long-term renewable fuels goals (Figure 1-8).

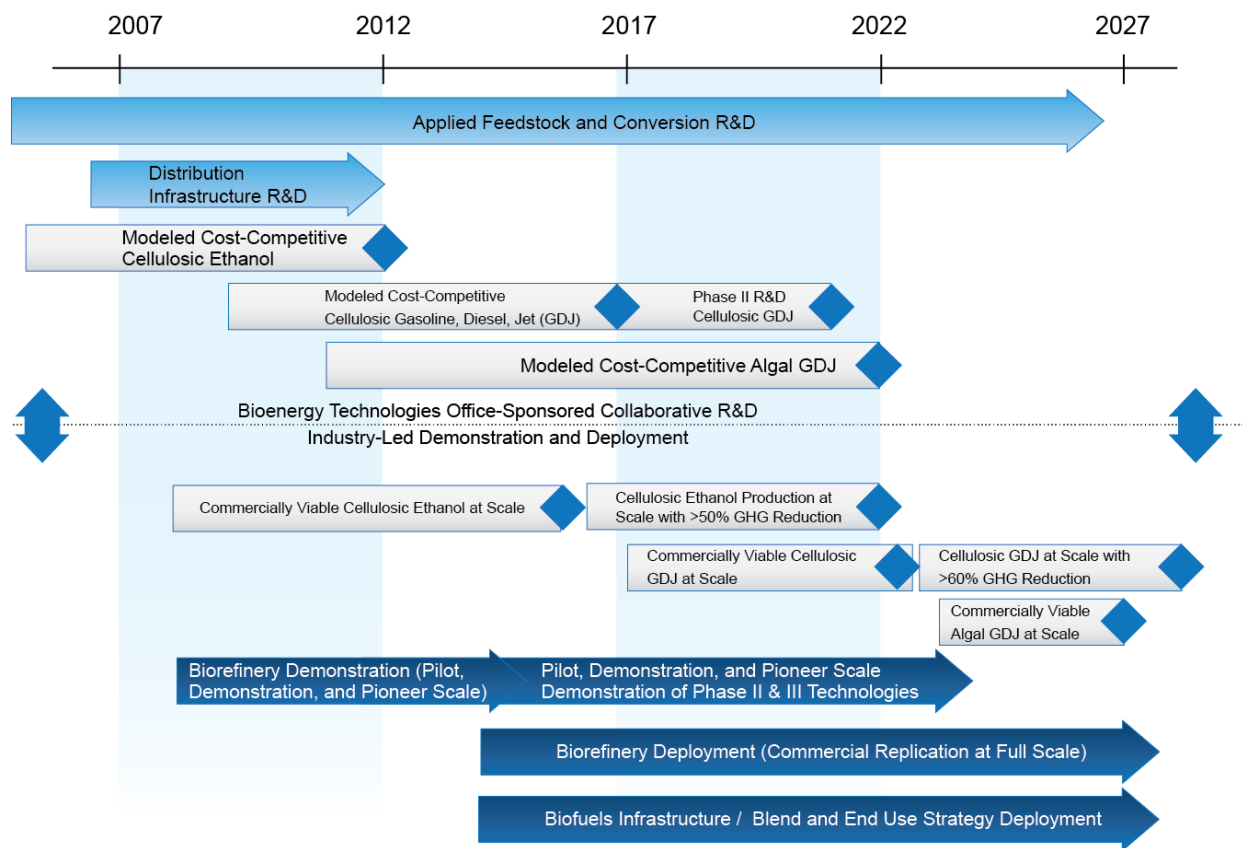

Figure 1-8: Bioenergy Technologies Office high-level schedule

The strategic goals for each element support the Office’s overarching strategic goal, as shown in Figure 1-9. These goals are integrally linked; demonstration and validation activities, for example, will depend on an available, sustainable feedstock supply, commercially viable conversion technologies, adequate distribution infrastructure, and strategic alliances and outreach to catalyze market expansion.

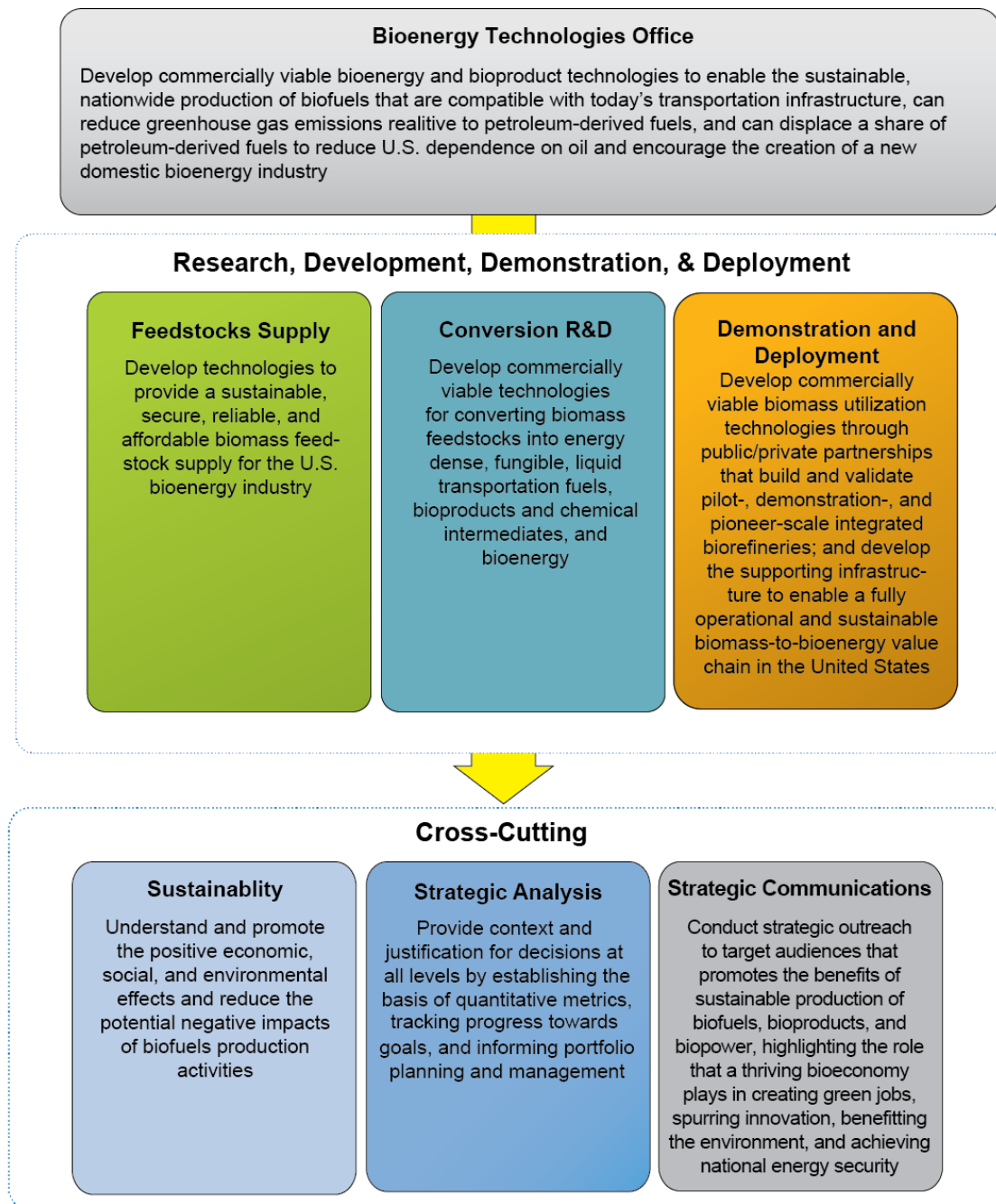

Figure 1-9: Strategic goals for the Bioenergy Technologies Office

1.4.2 Office Performance Goals

The overall performance goals set for the Office are shown below. These goals reflect the strategy of making advanced biofuels—renewable gasoline, diesel, and jet—commercially viable, as the most effective path for stimulating an emerging bioenergy economy.

- By 2017, validate, at a pilot scale, at least one technology pathway for hydrocarbon biofuel production at a mature modeled price of \$3/GGE with GHG emissions reduction of 50% or more compared to petroleum fuel.
- By 2022, validate hydrocarbon biofuels production from at least two additional technology pathways at a pilot or demonstration scale (>1 ton/day).

1.4.3 Office Multi-Year Targets

The Office's multi-year targets for 2014–2022 are listed in Table 1-3, while the high-level milestones leading to these targets are listed in Table 1-4. Section 2 describes the technical element performance goals and high-level milestones for all Office technical areas in more detail.

Table 1-3: Office Multi-Year Performance Goals

Feedstock Supply and Logistics R&D
<p>Terrestrial Feedstocks Supply and Logistics R&D</p> <ul style="list-style-type: none"> Validate efficient, low-cost, and sustainable feedstock supply and logistics systems that can deliver feedstock to the conversion reactor throat at required conversion process in-feed specifications, at or below \$80/dry ton (\$2011) by 2017 (including grower payment/stumpage fee) Establish geographic, economic, quality, and environmental criteria under which the industry could operate at 250 million dry ton per year scale (excluding biopower) by 2017 By 2022, develop and validate feedstock supply and logistics systems that can economically and sustainably supply 350 million dry tons per year at a delivered cost of \$80/dry ton to support a biorefining industry (i.e., multiple biorefineries) utilizing diverse biomass resources
<p>Algal Feedstocks</p> <ul style="list-style-type: none"> Demonstrate technologies to produce sustainable algal biofuel intermediate feedstocks that perform reliably in conversion processes to yield renewable diesel, jet, and gasoline fuels in support of the Office's \$3/GGE advanced biofuels goal by 2022
Conversion R&D
<p>Biochemical Conversion R&D</p> <ul style="list-style-type: none"> By 2017, achieve an nth plant modeled conversion cost of \$3.30/GGE utilizing blended formatted biomass via a biochemical conversion pathway
<p>Thermochemical Conversion R&D</p> <ul style="list-style-type: none"> By 2017, achieve an nth plant modeled conversion cost of \$2.50/GGE via a thermochemical pathway
Demonstration and Deployment
<ul style="list-style-type: none"> By 2014, validate three cellulosic ethanol or bioproduct manufacturing processes at pioneer scale By 2017, validate a mature technology modeled cost of cellulosic ethanol production, based on actual integrated biorefinery performance data, and compare to the target of \$2.15/gallon ethanol (\$2007) By 2027, validate a mature technology modeled cost of infrastructure-compatible hydrocarbon biofuel production, based on actual integrated biorefinery performance data, and compare to the target of \$3/GGE (\$2011)
Sustainability
<ul style="list-style-type: none"> By 2014, quantify the water footprint of cellulosic feedstocks at the county level, identify modeled feedstock production systems that increase energy crop production and agricultural residue removal by 50%, increase soil quality by at least 5%, and improve water quality compared to traditional agricultural management By 2017, identify conditions under which at least one technology pathway for hydrocarbon biofuel production, validated above R&D scale at a mature modeled price of \$3/GGE, reduces GHG emissions by 50% or more compared to petroleum fuel, and meets targets for consumptive water use, wastewater, and air emissions By 2022, validate landscape design approaches for two bioenergy systems that, when compared to conventional agricultural and forestry production, increase land-use efficiency and maintain ecosystem and social benefits, including biodiversity and food, feed, and fiber production By 2022, evaluate environmental and socioeconomic indicators across the supply chain for three cellulosic and algal bioenergy production systems to validate GHG reduction of at least 50% compared to petroleum, socioeconomic benefits including job creation, water consumption equal to or less than petroleum per unit fuel produced, and wastewater and air emissions that meet federal regulations
Strategic Analysis
<ul style="list-style-type: none"> Ensure high-quality, consistent, reproducible, peer-reviewed analyses Develop and maintain analytical tools, models, methods, and datasets to advance the understanding of bioenergy and its related impacts Convey the results of analytical activities to a wide audience, including DOE management, Congress, the White House, industry, other researchers, other agencies, and the general public
Strategic Communications
<ul style="list-style-type: none"> Increase awareness of and support for the Office's advanced biomass RD&D and technical accomplishments, highlighting their role in achieving national renewable energy goals Educate audiences about the environmental, economic, and social benefits of biomass as a viable alternative to fossil fuels, as well as the potential for advanced biofuels to displace petroleum-based transportation fuels

Table 1-4: Office Multi-Year Milestones for 2013–2022

Feedstocks Supply and Logistics R&D
Terrestrial Feedstocks Supply and Logistics R&D
Supply
<ul style="list-style-type: none"> By 2014, establish a framework for promoting sustainable biomass production practices that consider productivity, soil quality, water quality and quantity, greenhouse gas emissions, air quality, biodiversity, and social aspects of sustainability
<ul style="list-style-type: none"> By 2015, integrate feedstock quality criteria and blending strategies to generate more comprehensive supply scenarios, meeting biorefinery infeed specification targets at the lowest possible feedstock price
<ul style="list-style-type: none"> By 2016, produce an updated, fully integrated assessment of potentially available feedstock supplies under previously established environmental and quality criteria
<ul style="list-style-type: none"> By 2017, establish available resource volumes for non-woody municipal solid waste and algal feedstocks at \$80/dry ton delivered cost. (Note that woody municipal solid waste is currently incorporated into resource assessments)

<ul style="list-style-type: none"> By 2018, establish sub-county-level environmental impact criteria and logistics strategies
<ul style="list-style-type: none"> By 2019, determine impact of international trade and competing feedstock demands (e.g., biopower and pellet exports) on feedstock supply and price projections
<ul style="list-style-type: none"> By 2021, determine the impact of advanced blending and formulation concepts on available volumes that meet quality and environmental criteria, while also meeting the \$80/dry ton cost target
Feedstock Logistics
<ul style="list-style-type: none"> By 2015, develop a blendstock formulation for one conversion pathway based upon meeting pathway cost, quality, and volume targets
<ul style="list-style-type: none"> By 2017, validate sustainable feedstock supply and logistics cost of \$80/dry ton at conversion reactor throat (including grower payment and logistics cost) for at least one biochemical and one thermochemical conversion process
<ul style="list-style-type: none"> By 2022, validate one blendstock for thermochemical conversion and one blendstock for biochemical conversion at a scale of 1 ton per day
Algal Feedstocks
<ul style="list-style-type: none"> By 2014, demonstrate at research scale algae yield of 1,500 gallons of equivalent biofuel intermediate per acre per year
<ul style="list-style-type: none"> By 2016, review integrated R&D approaches for high-yielding algal biofuel intermediates to evaluate potential approaches for achieving the 2018 and 2022 milestones
<ul style="list-style-type: none"> By 2017, model the sustainable supply of 1 million metric ton ash free dry weight (AFDW) cultivated algal biomass
<ul style="list-style-type: none"> By 2018, demonstrate at non-integrated process development unit-scale algae yield of 2,500 gallons or equivalent of biofuel intermediate per acre per year
<ul style="list-style-type: none"> By 2022, model the sustainable supply of 20 million metric ton AFDW cultivated algal biomass and demonstrate at non-integrated process development unit-scale algae yield of 5,000 gallons biofuel intermediate per acre per year in support of nth plant model \$3/GGE algal biofuels
<ul style="list-style-type: none"> By 2025, demonstrate at integrated process development unit-scale algal productivity of greater than 5,000 gallons biofuel intermediate per acre per year
<ul style="list-style-type: none"> By 2030, validate production of algae-based biofuels at total production cost of \$3/GGE (2011\$), with or without co-products
Conversion R&D
Biochemical Conversion R&D
<ul style="list-style-type: none"> By 2014, establish out-year cost goals and technical targets for catalytically derived hydrocarbon fuels based on techno-economic analysis for one technology pathway
<ul style="list-style-type: none"> By 2017, validate the integrated production of a hydrocarbon fuel or fuel blend stock from cellulosic or algal biomass via at least one biological or chemical route at integrated bench scale to measure progress against an interim modeled cost goal (nth plant, \$2011)
Thermochemical Conversion R&D
<ul style="list-style-type: none"> By 2014, establish out-year conversion cost projections and technical targets for achieving the \$3/GGE goal based on a techno-economic analysis for at least one gaseous intermediate pathway that produces gasoline and diesel blendstock fuels
<ul style="list-style-type: none"> By 2015, select a thermochemical pathway for initially integrated operations to validate the Office's goal of \$3/GGE by 2017 by evaluating R&D data from bench-scale, semi-integrated thermochemical pathways that produce gasoline and diesel blendstock fuels
<ul style="list-style-type: none"> By 2017, validate the R&D performance goal of \$2.50/GGE nth plant modeled conversion cost and thus the Office's performance goal of \$3.00/GGE MFSP by performing integrated operations using on-specification feedstock via a thermochemical pathway that produces gasoline and diesel blendstock fuels
<ul style="list-style-type: none"> By 2020, select another thermochemical pathway for integrated operations to validate the 2022 Office goal of \$3/GGE by evaluating R&D data from bench-scale, semi-integrated thermochemical pathways that produce gasoline and diesel blendstock fuels
<ul style="list-style-type: none"> By 2022, validate the Office performance goal of \$3/GGE by performing integrated operations using on-specification blended, low-cost feedstock via a thermochemical pathway that produces gasoline and diesel blendstock fuels
Demonstration and Deployment
<ul style="list-style-type: none"> By 2018, validate three infrastructure-compatible hydrocarbon biofuel or bioproduct manufacturing processes at pilot scale
<ul style="list-style-type: none"> By 2020, validate one to two infrastructure-compatible hydrocarbon biofuel or bioproduct manufacturing processes at demonstration scale
<ul style="list-style-type: none"> By 2024, validate one infrastructure-compatible hydrocarbon biofuel or bioproduct manufacturing process at appropriate scale
Sustainability
Analysis and Communication
<ul style="list-style-type: none"> By 2015, identify practices that improve sustainability and environmental performance of advanced bioenergy, including results from a comprehensive case study of environmental, social, and economic sustainability indicators for a cellulosic feedstock production and biorefinery system
<ul style="list-style-type: none"> By 2016, coordinate with feedstock logistics and conversion R&D areas to set targets for GHG emissions, consumptive water use, wastewater, and air emissions for at least three renewable hydrocarbon pathways to be validated in 2017 and 2022
Sustainable System Design
<ul style="list-style-type: none"> By 2015, identify conditions under which a national 2030 feedstock production scenario can be achieved that, when

<p>compared to the projected U.S. Department of Agriculture baseline, improves average water quality in major feedstock production regions; does not increase consumptive water use per unit of fuel produced; maintains soil quality and biodiversity; and does not impact projected needs for food, feed, and fiber production</p>
<ul style="list-style-type: none"> ▪ By 2018, using available field data, validate case studies of optimized feedstock production systems that reduce GHG emissions and maintain or improve water quality and soil quality compared to conventional agriculture and forestry systems; identify generalizable conclusions and strategies to translate optimized scenarios into practice
<p>Strategic Analysis</p>
<ul style="list-style-type: none"> ▪ By 2014, coordinate the delivery of new design cases and corresponding life-cycle assessments for at least two technology pathways for conversion of biomass to hydrocarbon biofuels
<ul style="list-style-type: none"> ▪ By 2015, complete an assessment of the size and composition of current and potential markets for biofuels and bioproducts
<ul style="list-style-type: none"> ▪ By 2016, develop and deploy a consistent methodology for including co-products in techno-economic analyses and design cases
<ul style="list-style-type: none"> ▪ By 2017, identify near-term technology pathways for the Office based on reassessment of current state of technology development
<ul style="list-style-type: none"> ▪ By 2018, complete analysis on impact of advanced biofuels use on gasoline and diesel prices
<ul style="list-style-type: none"> ▪ By 2022, identify near-term technology pathways for the Office based on reassessment of current state-of-technology development
<p>Strategic Communications</p>
<ul style="list-style-type: none"> ▪ On an annual basis, complete outreach efforts focused on celebrating specific and timely Office contributions to new technologies, pathways, and directions, as Office-supported projects achieve important milestones and deliverables
<ul style="list-style-type: none"> ▪ By the end of 2014, determine three key Office messages that will be amplified throughout all Office outreach
<ul style="list-style-type: none"> ▪ By the end of 2014, complete outreach efforts focused on communicating the Office's successes in cellulosic ethanol to the ethanol-development community
<ul style="list-style-type: none"> ▪ By the end of 2014, in collaboration with Office leadership and Strategic Programs, identify highest-value media and target audiences and set goals for targeted outreach strategies and metrics that rely on appropriate communication channels (traditional and emerging) and carefully tailored messages and sub-messages
<ul style="list-style-type: none"> ▪ By the end of 2015, complete a national outreach campaign on the promise and benefits of developing biofuels, bioproducts, and biopower
<ul style="list-style-type: none"> ▪ By the end of 2014, complete outreach efforts focused on the GHG emission reductions resulting from biomass-derived alternative fuels
<ul style="list-style-type: none"> ▪ By the end of 2015, complete outreach efforts focused on landscape-scale environmental benefits of integrated biomass-based alternative fuels production with agricultural and other industrial activities
<ul style="list-style-type: none"> ▪ By the end of 2016, complete outreach efforts focused on future consumers and workforce that will support an emerging bioenergy industry

Section 2: Office Technology Research, Development, Demonstration, and Deployment Plan

The Bioenergy Technologies Office’s research, development, demonstration, and deployment (RDD&D) efforts are organized around three key technical and three key cross-cutting elements (see Figure 2-1). The first two technical elements—Feedstock Supply and Logistics R&D and Conversion R&D—primarily focus on research and development (R&D). The third technical area—Demonstration and Deployment—focuses on Integrated Biorefineries and Distribution Infrastructure. The cross-cutting elements—Sustainability, Strategic Analysis, and Strategic Communications—focus on addressing barriers that could impede adoption of bioenergy technologies. This organization of the work allows the Office to allocate resources for pre-commercial technology development, as well as for demonstration of technologies across the biomass-to-bioenergy and bioproducts supply chain.

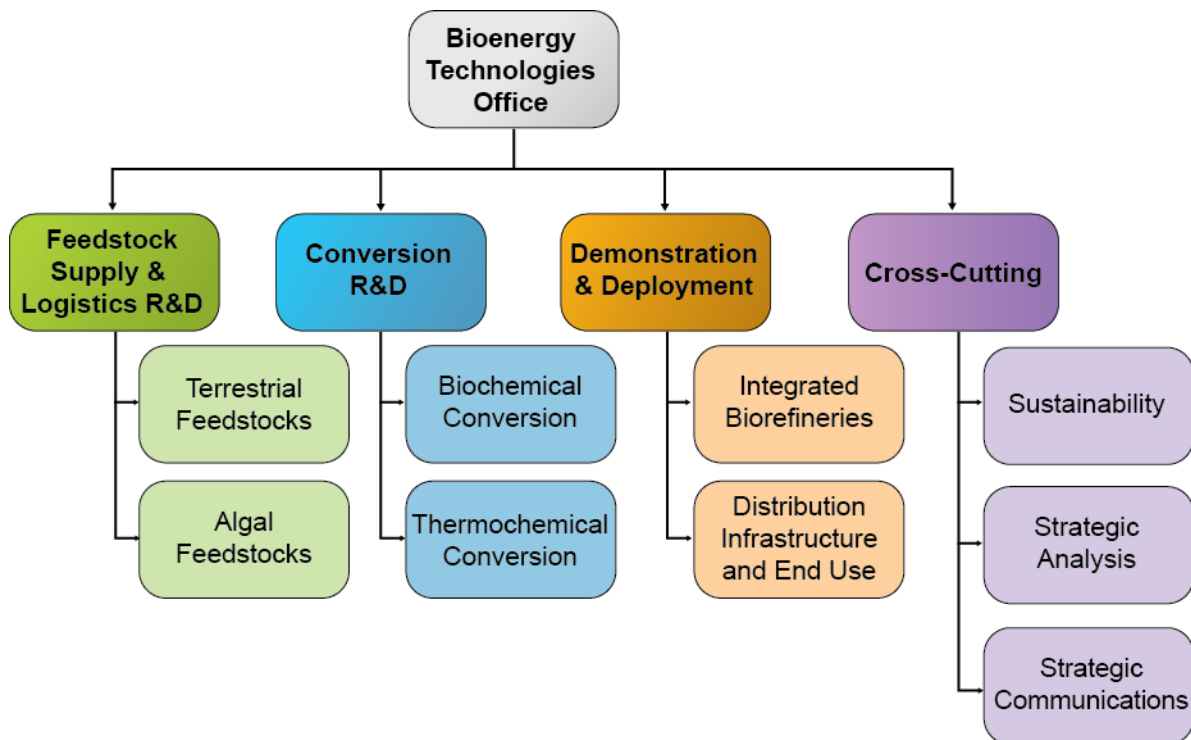

Figure 2-1: Bioenergy Technologies Office work breakdown structure

Bioenergy Technologies Office Organization

Research and Development

The R&D activities sponsored by the Office are focused on addressing technical barriers, providing engineering solutions, and developing the scientific and engineering underpinnings of emerging biofuels, bioproducts, and biopower industries. Near- to mid-term R&D is focused on moving current feedstock and conversion technologies from concept to bench to pilot scale. The goal of longer-term-focused R&D is to accelerate implementation of the technologies by developing deeper knowledge of terrestrial and algal biomass, feedstock supply systems,

biological systems, and biochemical and thermochemical conversion processes. This knowledge can ultimately be used to develop new or improved technologies that increase available low-cost biomass supplies, improve conversion efficiency, and reduce conversion cost while reducing carbon dioxide equivalent emissions and water use. Office-funded R&D is performed by national laboratories, industry, and universities.

The Office's R&D includes two technical elements:

- **Feedstock Supply and Logistics R&D** is focused on developing technologies to provide a reliable, affordable, and sustainable¹ biomass supply to enable a nascent and growing bioenergy industry. This R&D is focused on two areas—terrestrial feedstocks and algal feedstocks. R&D for development and production of terrestrial biomass feedstocks is led by the U.S. Department of Agriculture (USDA) in partnership with the U.S. Department of Energy (DOE) and other federal agencies, and it is coordinated through the Biomass R&D Board, which was established by the Energy Policy Act of 2005 (EPA 2005). The Bioenergy Technologies Office's primary focus in this area is on feedstock resource assessment and feedstock logistics (i.e., harvesting, storage, preprocessing, and transportation). R&D for the algal feedstocks area is led by DOE and includes resource assessment, strain improvement, efficient cultivation systems, harvest/dewatering, sustainable intermediate production, and stabilization (for details, see Section 2.1).
- **Conversion R&D** is focused on developing commercially viable technologies to convert terrestrial and algal feedstocks into liquid fuels, as well as bioproducts and biopower. The Office's Biochemical Conversion R&D efforts focus on pathways that produce sugars, other carbohydrate intermediates, and lignins from biomass, and converting those intermediates into fuels, chemical intermediates, or products. The Office's Thermochemical Conversion R&D efforts focus on pathways that produce oil, vapor, and gaseous intermediates from biomass, and converting these intermediates into fuels, chemical intermediates, products, and/or power (for details, see Section 2.2).

Demonstration and Deployment

The Office's Demonstration and Deployment activities focus on validating integrated biorefinery (IBR) applications at increasing engineering scale and biofuel distribution infrastructure and end use. For biofuels, the goal of demonstration and deployment activities is to develop emerging conversion technologies beyond bench scale to pre-commercial demonstration scale, reducing technical risk at increasing complexities and scale, culminating in the construction of pioneer biofuels production plants by industry. The second technology demonstration and deployment goal is to develop the supporting infrastructure needed to enable a fully developed, operational, and sustainable biomass-to-bioenergy value chain in the United States. Demonstration and

¹ The Bioenergy Technologies Office's approach to sustainability is consistent with Executive Order 13514, which provides the following definition: To create and maintain conditions, under which humans and nature can exist in productive harmony, that permit fulfilling the social, economic, and other requirements of present and future generations. For more on sustainability, see Section 2.4.

deployment is conducted via Office partnerships with industry and other key stakeholders and includes two technical elements:

- IBR** activities focus on demonstration of integrated conversion processes at an engineering scale sufficient to demonstrate and validate commercially acceptable cost, performance, and environmental targets. IBR activities address problems encountered in the so-called “Valley of Death” between pilot-scale and pioneer-scale first-of-a-kind demonstration, as illustrated in Figure 2-2. These efforts are industry-led, cost-shared, and competitively awarded projects. Intellectual property and geographic and market factors will determine the feedstock and conversion technology options that industry will choose to demonstrate and commercialize. Government cost share of biorefinery development is essential due to the high technical and financial risk of first-of-a-kind biofuels production at increasing scale. The Office will continue to fund a number of pilot-scale, demonstration-scale, and commercial-scale biofuel production facilities over the next 10 years (see Section 2.3.1).
- Biofuels Distribution Infrastructure and End Use** activities focus on coordinating with other federal agencies and DOE offices to develop the required biofuels distribution and end-use infrastructure. These activities include evaluating the performance; material compatibility; and environmental, health, and safety impacts of advanced biofuels and biofuel blends (see Section 2.3.2).

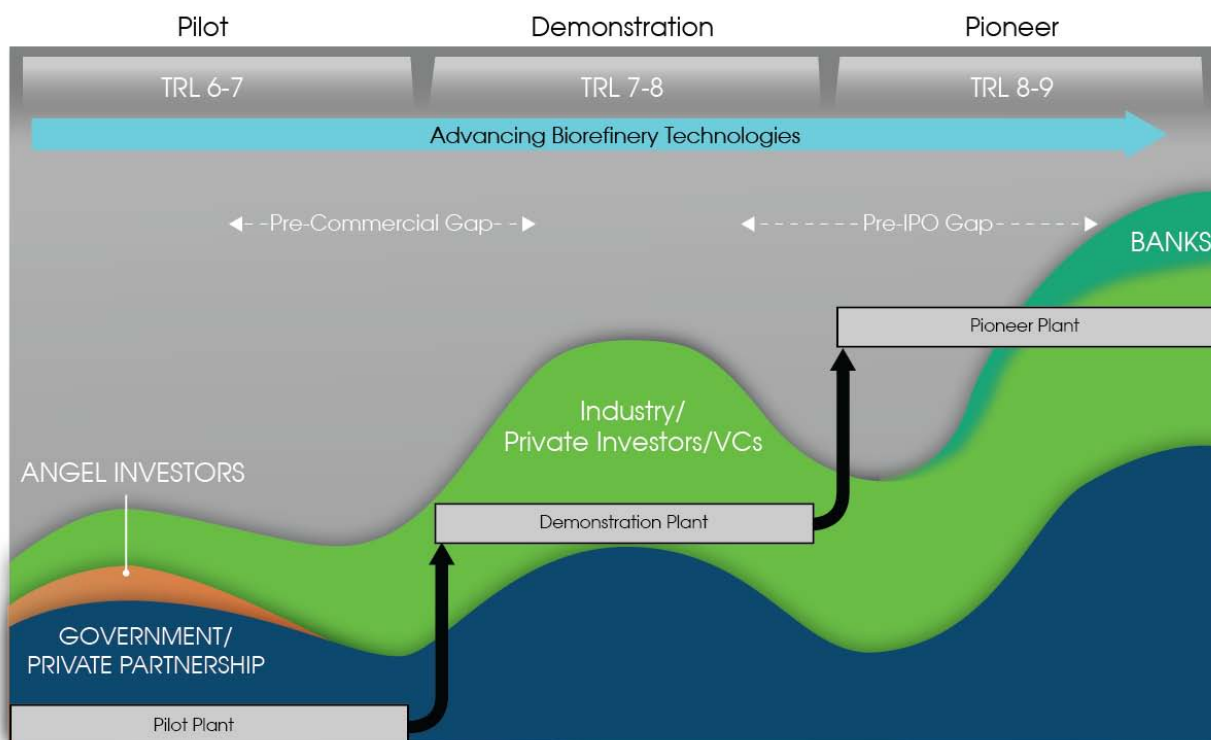

Figure 2-2: Technology development and scale-up to first-of-a-kind pioneer facility

Cross-Cutting Activities

- **Sustainability** activities focus on developing the resources, technologies, and systems needed to grow a bioenergy industry in an environmentally sustainable way. While petroleum displacement is at the core of the Office’s mission, improving long-term sustainability is also important. The existing and emerging bioenergy industry—which includes such diverse sectors as agriculture, waste management, automobile manufacturing, and fuel distribution—will need to invest in systems based on economic viability and market needs, while also addressing the more overarching concerns such as food security and environmental sustainability. The Office is working to articulate the challenges related to sustainable bioenergy production and partnering with other agencies and DOE offices to address these challenges through basic and applied research and analysis (see Section 2.4).
- **Strategic Analysis** includes a broad spectrum of cross-cutting analyses to support programmatic decision making, demonstrate progress toward goals, and direct research activities. Programmatic analysis helps frame the overall Office goals and priorities and covers issues that impact all technology areas, such as life-cycle assessment (LCA) of carbon dioxide equivalent emissions from bioenergy and bioproducts. These analyses provide inputs into DOE and Office of Energy Efficiency and Renewable Energy (EERE) strategic plans—including the President’s Climate Action Plan—and help define the impact of bioenergy on petroleum utilization in the transportation sector. Technology area analysis helps to monitor Office accomplishments in each technology area. Continued public-private partnerships with the bioenergy scientific community and multi-laboratory coordination efforts will help ensure that the model assumptions and analysis results from the Office are transparent, transferable, and comparable (see Section 2.5).
- **Strategic Communications** focuses on identifying and addressing non-technical and market barriers to bioenergy adoption and utilization in an effort to promote full-scale market penetration. It fosters awareness and acceptance by engaging a range of stakeholders in meaningful collaborations, promoting Office strategies, and increasing consumer acceptance. Strategic Communications activities include distributing information to stakeholders and conveying key Office goals, priorities, activities, and accomplishments (see Section 2.6).

The Office’s Technology Pathways Framework

The technology pathways framework integrates efforts among the technical elements and aligns with major bioenergy industry market segments. Figure 2-3 illustrates how the Office elements seek to leverage the broad diversity of potential bioenergy feedstocks while reducing supply risks through developing a wide range of conversion technologies to produce and distribute bioenergy and bioproducts.

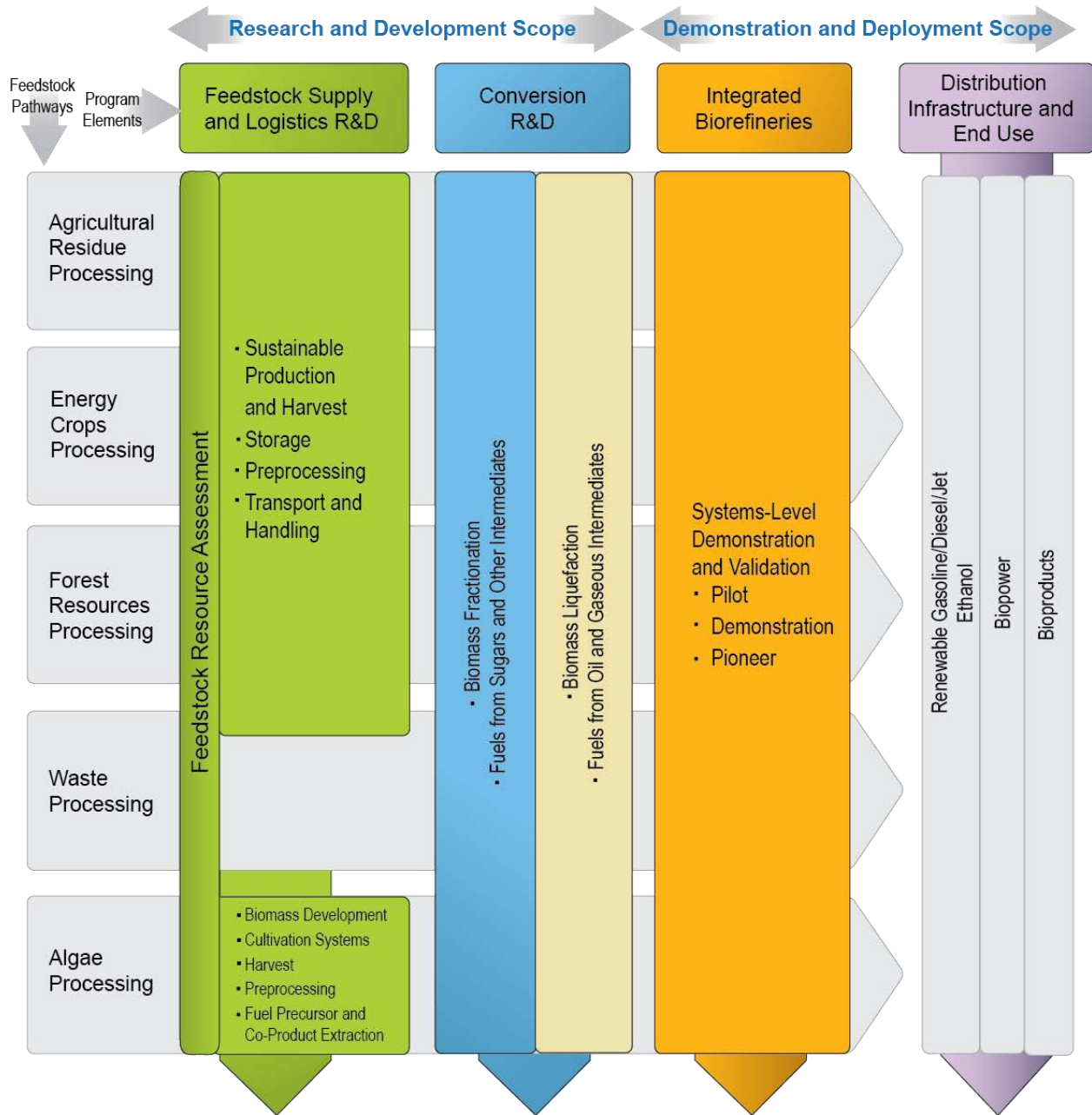

Figure 2-3: Office technical element links to technology pathway framework

The Office uses this technology pathway framework to identify research, development, and demonstration (RD&D) priorities and balance the activities that are expected to have the greatest impact on achieving Office goals.

Office Element Discussion

The remainder of Section 2 details plans for each Office element:

- Feedstock Supply and Logistics R&DSection 2.1
- Conversion R&D.....Section 2.2

Demonstration and Deployment	Section 2.3
Sustainability	Section 2.4
Strategic Analysis	Section 2.5
Strategic Communications	Section 2.6

Each element discussion is organized as follows:

- Brief overview of the element process concept and its interfaces with other elements of the Office (in the context of the biomass-to-bioenergy supply chain)
- Element strategic goal, as derived from the Office strategic goals
- Element performance goals, as derived from the Office performance goals
- Technical and market challenges and barriers
- Strategies for overcoming barriers, the basis for element work breakdown structures (WBS; tasks and activities with links to barriers)
- Prioritization, milestones, and timelines.

2.1 Feedstock Supply and Logistics Research and Development

The strategic goal of Feedstock Supply and Logistics (FSL) is to *develop technologies to provide a sustainable, secure, reliable, and affordable biomass feedstock supply for the U.S. bioenergy industry*, in partnership with USDA and other key stakeholders.

As the starting material for biofuels, bioproducts, and biopower production, reaching industrial scale will require availability of and access to a reliable supply of affordable, high-quality biomass. As shown in Figure 2-4, FSL research and development (R&D) relates directly to, and strongly influences, all downstream elements of the biomass-to-bioenergy supply chain, as well as the achievement of all Office goals and objectives.

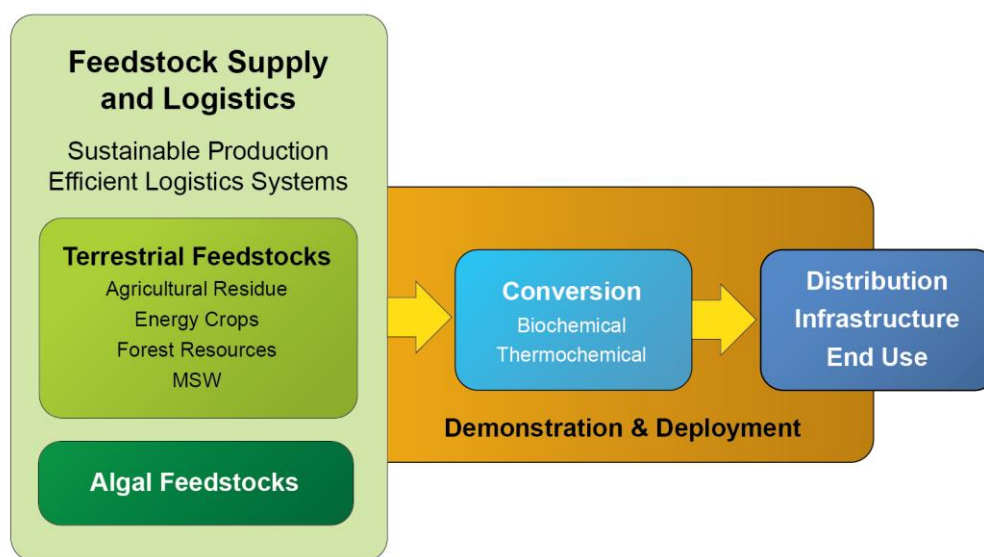

Figure 2-4: Feedstock supply and logistics as the starting point for the bioenergy supply chain

FSL distinguishes “biomass” from “feedstock.” “Biomass” is defined as the raw, field-run material obtained at the site of production (e.g., field, forest, or pond). Examples of biomass include corn stover, switchgrass, miscanthus, energy cane, sweet sorghum, high biomass sorghum, hybrid poplars, shrub willows, the sorted organic portion of municipal solid waste (MSW), and whole algae. “Feedstock” denotes biomass materials that have undergone preprocessing, such as drying, milling or chopping, size fractionation, de-ashing, blending and formulation, densification, or extraction to make them acceptable for feeding into a biorefinery process that converts them to biofuels, biopower, and/or bioproducts.

FSL R&D is organized into two broad categories of feedstock: (1) terrestrial feedstocks, which include lignocellulosic feedstocks such as agricultural residues, forest resources, dedicated energy crops,² and select MSW resources; and (2) algal feedstocks. Research objectives for these

² Energy crops are produced primarily to be feedstocks for energy production—as opposed to an agricultural or forest residue, which is produced as a byproduct of another valuable commodity such as grain or lumber.

two categories of feedstocks are discussed separately. Section 2.1.1 is focused on terrestrial feedstocks, and Section 2.1.2 is focused on algal feedstocks.

The Office anticipates that USDA will lead the federal government's terrestrial feedstock production efforts, in accordance with the February 3, 2010, White House release of "Growing America's Fuel."³ However, the Office continues to lead the federal government's terrestrial feedstock logistics efforts. The Office will work with USDA to coordinate USDA's and other's efforts to support the development of a robust and sustainable domestic bioenergy industry.

The Office anticipates playing a leading role in the federal government's algae strain development, as well as production and logistics efforts related to algal feedstock systems. Algae production systems include open ponds, closed photobioreactors, mixotrophic growth, attached growth, and on- and off-shore macroalgae cultivation. Heterotrophic algae fermentation strategies are discussed in the Biochemical Conversion R&D section of the MYPP (Section 2.2.1).

The FSL program coordinates with other DOE offices and federal agencies to stimulate the development and growth of the U.S. bioenergy industry, including the following:

- DOE—Advanced Research Projects Agency for Energy (ARPA-E); Office of Science via the Joint Genome Institute, as well as its three Bioenergy Research Centers and selected Energy Frontier Science Centers
- USDA—Agricultural and Food Research Institute's Regional Bioenergy Coordinated Agricultural Projects; Agricultural Research Service (ARS) and U.S. Forest Service (USFS) Regional Biomass Research Centers; ARS National Programs #213 ("Bioenergy") and #301 ("Plant Genetic Resources, Genomics and Genetic Improvement")
- DOE-USDA—Office of Science's and National Institute of Food and Agriculture's joint annual solicitation on feedstock genomics
- Interagency—Biomass Research and Development Board; Biomass Research and Development Initiative (both terrestrial and algal)
- National Science Foundation—Directorate for Engineering, partnership on Interagency Opportunities in Metabolic Engineering
- EPA—Office of Research and Development algae program; Office of Pollution Prevention and Toxics Biotechnology Program (genetically modified organisms)
- U.S. Department of Defense—Defense Production Act.

³ For more information, see http://www.whitehouse.gov/sites/default/files/rss_viewer/growing_americas_fuels.pdf.

2.1.1 Terrestrial Feedstock Supply and Logistics Research and Development

Feedstocks are essential to achieving Office goals because the cost, quality, and volume of feedstock available and accessible at any given time will determine the maximum amount of biofuels that can be produced. The *U.S. Billion-Ton Update*⁴ report provided biomass supply scenarios that show the potential biomass resource that could be developed, leading to a sustainable national supply of more than 1 billion tons of biomass per year by 2030.

Terrestrial FSL focuses on (1) reducing the delivered *cost* of sustainably produced feedstock, (2) preserving and improving the *quality* of harvested feedstock to meet the needs of biorefineries and other biomass users, and (3) expanding the *volume* of feedstock materials accessible to the bioenergy industry. This is done by identifying, developing, demonstrating, and validating efficient and economical systems for harvest and collection, storage, handling, and preprocessing⁵ raw biomass from a variety of crops to reliably deliver high-quality, affordable feedstocks to biorefineries as the industry expands.

Terrestrial FSL R&D includes two thrusts: (1) identifying and quantifying current and future land-based biomass resources and costs associated with their production and (2) designing integrated and efficient purpose-designed systems capable of delivering large volumes of feedstock that meet the quality specifications required by conversion facilities (see Figure 2-5).

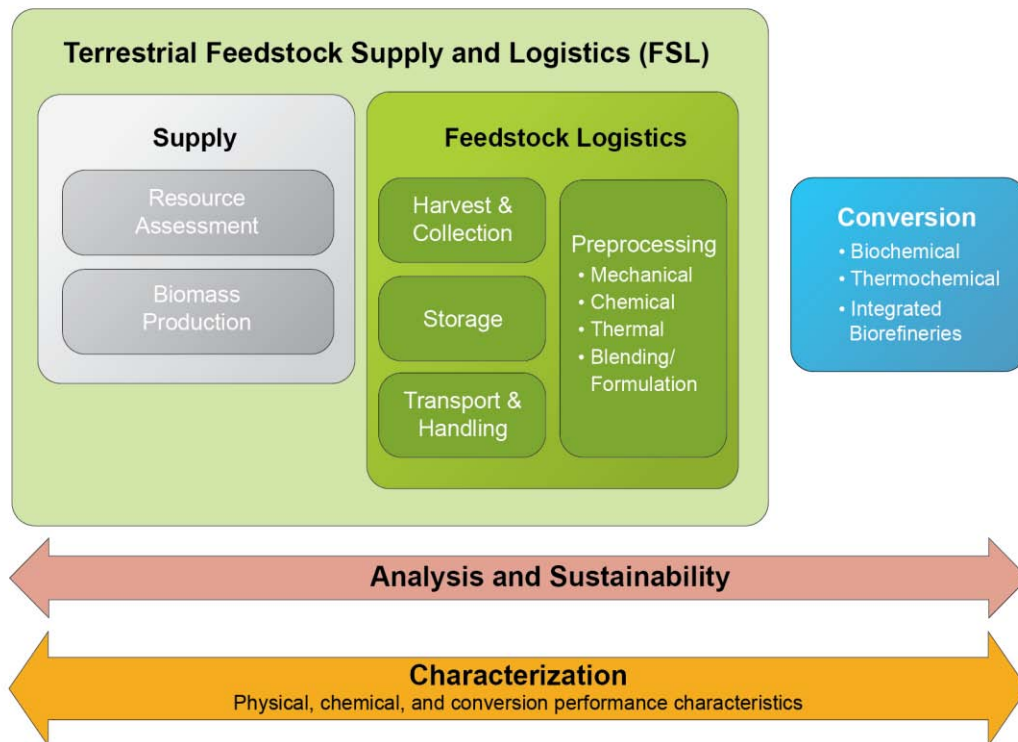

Figure 2-5: Terrestrial feedstock supply and logistics systems diagram

⁴ U.S. Department of Energy. 2011. *U.S. Billion-Ton Update: Biomass Supply for a Bioenergy and Bioproducts Industry*. R.D. Perlack and B.J. Stokes (Leads), ORNL/TM-2011/224. Oak Ridge National Laboratory, Oak Ridge, TN. http://www1.eere.energy.gov/biomass/pdfs/billion_ton_update.pdf.

⁵ Note that some preprocessing research is detailed in the sections describing conversion programs, while other research is detailed under the feedstock logistics portfolio.

Analysis and sustainability are cross-cutting areas that span both of these categories—analysis⁶ activities often incorporate both production and logistics data in the same way as sustainability⁷ activities and principles, including continuous improvement and minimization of inputs, such as water and soil conservation.

Supply: Supply includes assessing the potential availability and quality of biomass resources, as well as the production of biomass to demonstrate crop performance and estimate production costs under a variety of real-world conditions.

Resource Assessment involves estimating current and future domestic biomass resources by type and geographic distribution at different price points, understanding quality attributes (e.g., moisture, ash, and carbon content) associated with those resources as a function of geography and price, and evaluating the environmental sustainability constraints associated with accessing those biomass resources over time.

Characterization focuses on understanding biomass and feedstock quality and identification of physical, chemical, and conversion performance characteristics that can significantly impact conversion process yield, kinetics, and profitability, as well as logistics operations. Characterization involves analysis of raw biomass samples to identify a wide range of physical and chemical parameters, and the relationships of those parameters to conversion, to identify key variables and quantify their impact on overall production cost. It also includes the development of efficient, reliable, and affordable wet chemical and calibrated rapid analytical methods to measure biomass quality characteristics for woody and herbaceous crops, as well as relevant MSW fractions. Characterization research includes collaborative interface efforts between the Terrestrial FSL, Biochemical Conversion (see Section 2.2.1), and Thermochemical Conversion (see Section 2.2.2) Technology Areas.

Biomass Production involves all of the operations, associated costs, and sustainability issues related to site preparation, crop establishment, growth, and maintenance of terrestrial biomass crops to the point of harvest and collection. The Office partners with USDA in these efforts.

Feedstock Logistics: Feedstock logistics refers to all of the operations that occur after the biomass is produced and is standing in a field or forest ready for harvest and before it is introduced into the conversion facility in-feed system (also referred to as the “reactor throat”).

Harvest and Collection involves the cost-effective and sustainable removal of raw biomass from the field or forest. These operations play a critical role in expanding the amount of biomass resources accessible to the bioenergy feedstock supply system. The harvest window for different crops varies with the growth cycle of the crop, and harvest timing may be constrained by the growing season of a primary crop (e.g., grain), as well as by weather conditions during the harvest window. Harvest timing and strategy may affect the resulting herbaceous and woody feedstock quality parameters, such as chemical

⁶ Analysis is further described in Section 2.3.

⁷ Sustainability is further described in Section 2.4.

composition and structural features. Collection format (e.g., bales, loose chop, round wood, chips, etc.) can impact the efficiency and cost associated with downstream handling, storage, and transportation operations.

Storage includes methods and practices to cost-effectively store seasonally available herbaceous and woody biomass until required for processing, while minimizing degradation, material loss, and undesirable changes in quality characteristics. This includes inventory management to monitor and maintain biomass and feedstock quality, enable longer storage times, and minimize losses due to handling operations, microbial degradation, etc.

Preprocessing involves operations that transform raw, field-run biomass into stable, standardized format feedstocks with physical and chemical characteristics that meet the required quality specifications of conversion facilities and enable the use of existing, high-volume transportation and handling systems.⁸ Preprocessing upgrades biomass for stability during longer-term storage and improves durability and performance in handling, transport, and conversion. Preprocessing also can reduce the physical and chemical variability of raw biomass to enable more reliable, predictable, and efficient conversion performance.

Preprocessing includes mechanical, thermal, or chemical treatments, as well as blending and formulation. Any or all of these treatments can occur at various points in the logistics chain.

Mechanical preprocessing includes size reduction, separation based on particle size or density, and fractional deconstruction to reduce particle size and break down the raw biomass to achieve desired physical and/or chemical characteristics. Mechanical preprocessing also includes densification treatments, such as pelletization, to increase the bulk and energy density of raw biomass, improve stability during storage and handling, and create flowable feedstocks that are compatible with existing handling infrastructure systems. Although baling is a densification process, it is considered part of the Harvest and Collection operation.

Thermal preprocessing, such as drying and torrefaction, reduces moisture content and increases the energy density of the material to improve stability during storage, transport efficiency, and—potentially—conversion performance.

Chemical preprocessing upgrades biomass quality by reducing ash content, reducing recalcitrance to cell wall deconstruction, and potentially increasing downstream microbial conversion of biomass to products. Examples of chemical preprocessing include leaching or washing, treatment at basic pH, and dilute-acid treatment. Additional information on chemical preprocessing technologies can be found in the Biochemical Conversion R&D section (Section 2.2.1).

⁸ Note that some preprocessing operations are discussed under other program sections.

Formulation and blending mitigate inherent variability in raw biomass qualities to produce feedstock with more consistent physical and chemical characteristics, to reduce conversion performance variability, and/or to lower the overall cost of feedstocks. By combining biomass with different chemical, physical, and cost characteristics, feedstock quality and performance can be adjusted to required conversion process specifications and improve overall process economics. Blending and aggregation are examples of formulation processes. Including lower-quality or small-volume biomass materials as components of a blend or formulation can reduce the overall cost or adjust the physical or chemical characteristics of the blend. This can expand the volume of biomass available to biorefineries to mitigate feedstock supply risk and improve overall process economics.

Handling feedstocks in existing high-volume, high-throughput systems can be challenged by the low-density, non-uniform characteristics of raw biomass. Formatting raw biomass to be compatible with these systems as early in the supply chain as practical can leverage existing high-capacity bulk handling and transportation infrastructures, such as those designed for the grain industry, and help to reduce delivered feedstock cost.

Transport involves moving raw biomass from the field or forest to the site of preprocessing and moving preprocessed feedstocks to the throat of the conversion reactor. Biomass and feedstocks may be transported by truck, train, or barge using existing transportation infrastructure.

Connecting the Nation's Diverse Biomass Resource to the Bioenergy Industry

Sustainably supplying the required volumes of quality, affordable feedstock to the emerging biorefining industry will be achieved through a transition from logistics systems that have been designed to meet the needs of conventional agriculture and forestry systems (termed “conventional” logistics systems) to more advanced, purpose-designed, economically advantaged systems (termed “advanced” logistics systems).⁹

Conventional Logistics Systems: Conventional logistics systems have been developed for traditional agriculture and forestry systems and are designed to move biomass short distances for limited-time storage (i.e., less than one year). Conventional systems do not address the physical and chemical variability of biomass and do not access the full volume of the diverse, nationally distributed U.S. biomass resource potential. Conventional systems constrain biorefinery locations to areas where there are sufficient supplies of biomass within a limited distance, limit the scale-up capacity of the biorefinery, and expose the biorefinery and its investors to increased risk from potential local feedstock disruptions.¹⁰

Advanced Logistics Systems: Advanced logistics systems are designed to deliver infrastructure-compatible feedstocks with predictable physical and chemical characteristics, longer-term

⁹ J. Richard Hess, Christopher Wright, et al. “Uniform-Format Solid Feedstock Supply System: A Commodity-Scale Design to Produce an Infrastructure-Compatible Bulk Solid from Lignocellulosic Biomass,” Idaho National Laboratory, INL/EXT-08-14752 (2009), www.inl.gov/bioenergy/uniform-feedstock.

¹⁰ J. Richard Hess, Christopher Wright, et al., as above.

stability during storage, and high-capacity bulk material handling characteristics that facilitate economic transport over longer distances. These properties are needed for the development of a commodity-based, specification-driven supply system analogous to U.S. grain and coal commodity systems.

Logistics systems designed for the purpose of bioenergy production can eliminate inefficiencies in conventional harvest and delivery systems. Reducing the number of operations, pieces of equipment, and labor required per delivered ton of feedstock will enable implementation of additional operations, such as preprocessing, that do not occur in conventional systems. Methods will also be developed to estimate feedstock quality characteristics at critical points in the supply chain.

Figure 2-6 shows a high-level depiction of how an advanced logistics system could draw in presently inaccessible resources via local preprocessing depots that transform biomass into a stable, bulk, densified, and flowable feedstock. The formatted feedstock is transported into a network of supply terminals, where material aggregated from a number of depots can be blended or further preprocessed to meet biorefinery needs.

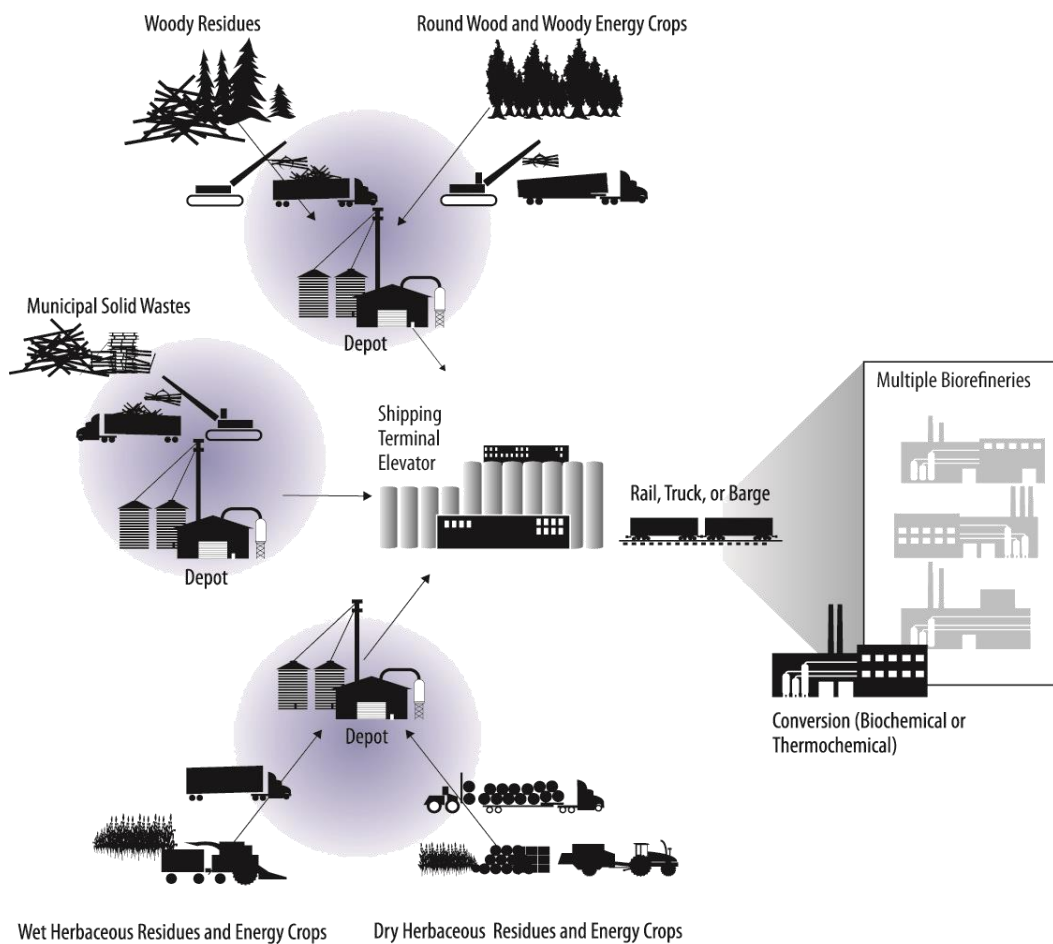

Figure 2-6: The advanced logistics system depot concept

2.1.1.1 Terrestrial Feedstock Supply and Logistics Research and Development Support of Office Strategic Goals

The strategic goal of Terrestrial FSL R&D is to *develop technologies to enable a sustainable, secure, reliable, affordable supply of acceptable-quality terrestrial feedstock for the U.S. bioenergy industry*, in partnership with USDA and other key stakeholders. This supports the long-term (beyond 2030) goal to develop technologies and methods that could sustainably supply more than 1 billion tons of biomass per year.

The Terrestrial FSL R&D program directly addresses and supports resource assessment, production, harvest, collection, storage, preprocessing, and delivery of feedstock for all potential biomass conversion pathways.

2.1.1.2 Terrestrial Feedstock Supply and Logistics Research and Development Support of Office Performance Goals

The performance goals for Terrestrial FSL R&D are as follows:

- Validate efficient, low-cost, and sustainable feedstock supply and logistics systems that can deliver feedstock to the conversion reactor throat at required conversion process in-feed specifications, at or below \$80/dry ton (\$2011) by 2017 (including grower payment/stumpage fee¹¹)
- Establish geographic, economic, quality, and environmental criteria under which the industry could operate at 245 million dry ton per year scale (excluding biopower) by 2017¹²
- By 2022, develop and validate feedstock supply and logistics systems that can economically and sustainably supply 285 million dry ton per year at a delivered cost of \$80/dry ton to support a biorefining industry (i.e., multiple biorefineries) utilizing a diversity of biomass resources.

Terrestrial Feedstock Supply and Logistics Research and Development Milestones

Terrestrial FSL R&D has several milestones charting the path to 2017 and 2022.

¹¹ Grower payments are those made to feedstock producers over and above the costs incurred for harvest, collection, storage, preprocessing, and transport. For crop residues, the grower payment covers the environmental value of the residue removed (e.g., nutrients and organic matter), as well as profit. For woody residues, these payments cover the value of the residue. For dedicated energy crops, grower payments cover pre-harvest machine costs, variable inputs such as fertilizers and seed, and amortized establishment costs for perennial crops, which do not typically reach mature yields until at least the third growing season. The payments must also reflect what profit the land could produce if planted with other crops. Other factors also affect grower payments include profits to growers for investment returns and risk taking, alternative financial arrangements (e.g., cooperatives), fixed pricing mechanisms, shared-equity arrangements between growers and processors, and other competitive uses. Note that the grower payment listed is the maximum amount required to acquire the specified volume of biomass (i.e., there are biomass resources available for a lower cost; however, none of the resources required would cost more). For a more extensive list of feedstocks and their associated grower payment, see Oak Ridge National Laboratory's Bioenergy Knowledge Discovery Framework at <https://www.bioenergykdf.net>.

¹² Table B-1 in Appendix B.

Supply

- By 2014, establish a framework for promoting sustainable biomass production practices that consider productivity, soil quality, water quality and quantity, greenhouse gas emissions, air quality, biodiversity, and social aspects of sustainability.¹³
- By 2015, integrate feedstock quality criteria and blending strategies to generate more comprehensive supply scenarios, meeting biorefinery in-feed specification targets at the lowest possible feedstock price.
- By 2016, produce an updated, fully integrated assessment of potentially available feedstock supplies under previously established environmental and quality criteria.
- By 2017, establish available resource volumes for non-woody MSW and algal feedstocks at \$80/dry ton delivered cost. (Note that woody MSW is currently incorporated into resource assessments.)
- By 2018, establish sub-county-level environmental impact criteria and logistics strategies.
- By 2019, determine the impact of international trade and competing feedstock demands (e.g., biopower and pellet exports) on feedstock supply and price projections.
- By 2021, determine the impact of advanced blending and formulation concepts on available volumes that meet quality and environmental criteria, while also meeting the \$80/dry ton cost target.

Feedstock Logistics

- By 2015, develop a blendstock formulation for one conversion pathway based upon meeting pathway cost, quality, and volume targets.
- By 2017, validate sustainable feedstock supply and logistics cost of \$80/dry ton at conversion reactor throat (including grower payment and logistics cost) for at least one biochemical conversion process and one thermochemical conversion process.
- By 2022, validate one blendstock for thermochemical conversion and one blendstock for biochemical conversion at a scale of 1 ton per day.

2.1.1.3 Terrestrial Feedstock Supply and Logistics Research and Development Technical Challenges and Barriers

Supply

Ft-A. Terrestrial Feedstock Availability and Cost: Reliable, consistent feedstock supply is needed to reduce financial, technical, and operational risk to biorefineries and their financial partners. Reaching federally mandated national volumes of biofuels will require large amounts of sustainably available, quality-controlled biomass to enter the market at an affordable price. Conventional logistics systems restrict the amount of biomass that can be cost-effectively delivered to the biorefinery, resulting in large amounts of biomass that cannot cost-effectively enter the system (i.e., “stranded resources”).

Credible data and projections on current and future cost, location, environmental sustainability, quality, and quantity of available biomass are needed to reduce uncertainty for investors and

¹³ The framework will be implemented in Office-funded activities and updated as best management practices are identified.

developers of emerging biorefinery technologies. Estimates of current and potential feedstock resources are limited in scope and do not adequately represent how major potential advances in genetics, production technologies, and supply chain strategies will impact future biomass availability, cost, and quality.

Ft-B. Production: The range of and improvements in energy crop yields have not been well-documented for deployment of energy crops at commercial scale. Reliable production data are needed over several growing seasons and across wide geographies to make well-substantiated productivity projections. Comprehensive data are also needed to measure the environmental effects of energy crop production and biomass collection systems to provide data for complete life-cycle analysis of biorefinery systems and address sustainability questions such as water and fertilizer inputs, or establishment and harvesting impacts on soil. Production and sustainability gaps also exist for conventional crop residues.

Ft-C. Terrestrial Feedstock Genetics and Development: The productivity and robustness of terrestrial feedstock crops used for biofuel production could be increased by developing improved varieties through screening, breeding and selection, and/or genetic engineering. This will require extensive ecological, genetic, and biochemical information that is currently lacking for the majority of non-domesticated terrestrial energy crops.

Feedstock Logistics

Ft-D. Sustainable Harvesting: Current crop harvesting machinery is unable to selectively harvest preferred components of cellulosic biomass while maintaining acceptable levels of soil carbon and minimizing erosion. Actively managing biomass variability imposes additional functional requirements on biomass harvesting equipment. Current systems cannot meet the capacity, efficiency, or delivered price requirements of large cellulosic biorefineries.

Ft-E. Terrestrial Feedstock Quality and Monitoring: A better understanding is needed regarding the physical, chemical, microbiological, and post-harvest physiological variations in biomass that arise from differences in genetics, degree of crop maturity, geographical location, climatic events, and harvest methods. This variability presents significant cost and performance risks for bioenergy systems. Currently, processing standards and specifications for cellulosic feedstocks are not as well-developed as for mature commodities.

Ft-F. Biomass Storage Systems: Biomass that is stored with high moisture content or exposed to moisture during storage is susceptible to spoilage, rotting, spontaneous combustion, and odor problems. Therefore, the impacts of these post-harvest biological processes must be controlled to ensure a consistent, high-quality feedstock supply. Characterization and analysis of different storage methods and strategies are needed to better define storage requirements to preserve the volume and quality of harvested biomass over time and maintain its conversion yield.

Ft-G. Biomass Material Properties and Variability: Available data and information are extremely limited on biomass quality and physical characteristics and how those properties influence conversion performance. Methods and instrumentation also are lacking for quickly, accurately, and economically measuring chemical, physical, and mechanical properties of biomass.

A better understanding is needed regarding the inherent variability in biomass physical and chemical quality parameters and cost between different species, within a species, and even between tissues of the same individual plant. Acceptable ranges of quality parameters for different conversion processes are poorly understood, and few genetic or preprocessing strategies have been developed to limit or control variability in biomass quality. Since many quality factors vary independently, it is not clear what fraction of available biomass materials will actually be able to meet in-feed specifications for the various conversion processes being developed and commercialized.

Ft-H. Biomass Physical State Alteration: The initial sizing and grinding of cellulosic biomass affects conversion efficiencies and yields of all downstream operations, yet little information exists on how specific differences in these operations on each type of cellulosic biomass impact conversion cost and yields. New technologies and equipment are required to economically process biomass to meet biorefinery specifications, such as particle-size distribution.

Ft-I. Biomass Material Handling and Transportation: Raw herbaceous biomass is costly to collect, handle, and transport because of its low density and fibrous nature. Existing conventional, bale-based handling equipment and facilities cannot cost-effectively deliver and store high volumes of biomass, even with improved handling techniques. Current handling and transportation systems designed for moving woodchips can be inefficient for bioenergy processes due to the costs and challenges of transporting, storing, and drying high-moisture biomass.

Ft-J. Overall Integration and Scale-Up: Conventional supply systems used to harvest, collect, store, handle, and transport biomass are not designed for the large-scale needs of a nationwide system of integrated biorefineries. The infrastructure for feedstock logistics has not been defined for the potential variety of locations, climates, feedstocks, storage methods, processing alternatives, etc., which will occur at a national scale. Integration of one or more aspects of the feedstock supply system—either alone or in combination with biorefinery operations—should lead to net gains in efficiency; however, the lack of analysis quantifying the relative benefits and drawbacks of potential integration options is a barrier to realization of cost savings, biorefinery efficiency improvement, and reduction of technical and financial risk.

2.1.1.4 Terrestrial Feedstock Supply and Logistics Research and Development Approach for Overcoming Challenges and Barriers

The Terrestrial FSL R&D approach for overcoming feedstock supply and logistics challenges and barriers is outlined in the work breakdown structure (WBS) and organized around the following key activities, as shown in Figure 2-7: Resource Assessment (including Analysis and Sustainability), Biomass Production, Harvest and Collection, Preprocessing, Transport and Handling, Conversion Interface, and Storage.

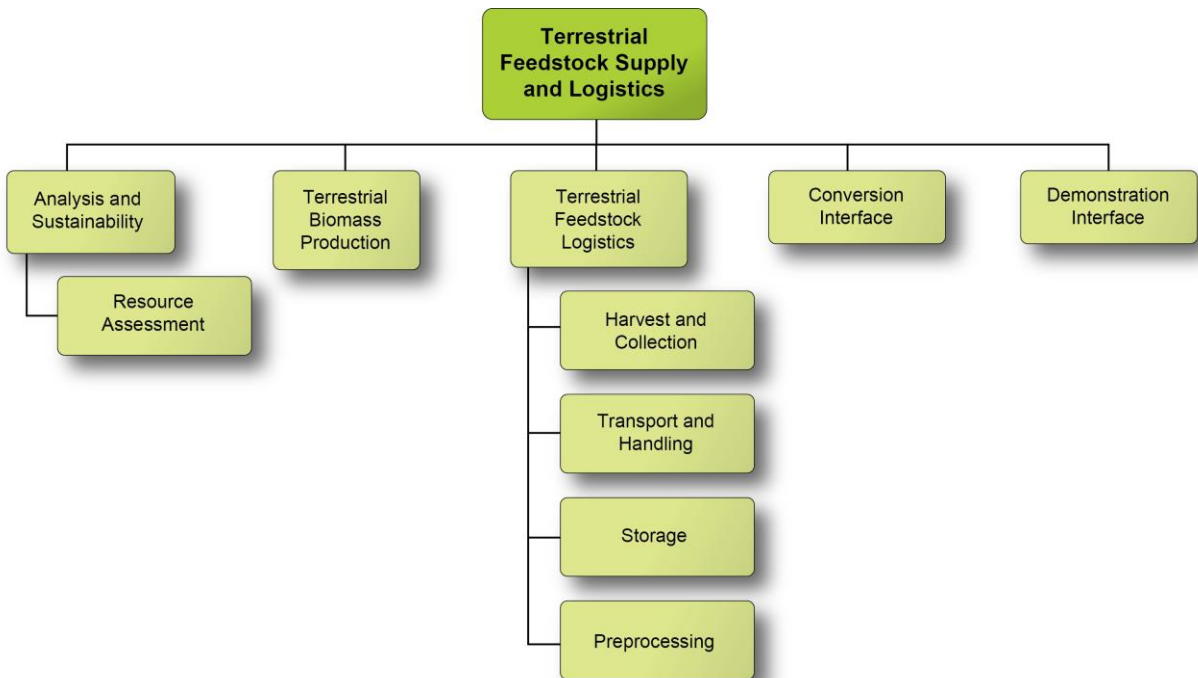

Figure 2-7: Terrestrial feedstock R&D work breakdown structure

Office-funded Terrestrial FSL system activities are performed by national laboratories, universities, industry, consortia, and a variety of state and regional partners.

The R&D approach of each WBS activity is described below.

Analysis and Sustainability

Primary areas of work within Analysis and Sustainability include resource assessment, system cost analyses, and risk assessment. Resource assessment provides critical data for establishing and measuring progress toward Office goals by determining the volume of biomass available and at what price, as well as the location of the biomass. Location and yield of biomass, as well as price, are necessary for determining total delivered feedstock cost. Resource assessment includes establishing a national inventory of biomass resource potential and assessing current and future environmentally sustainable biomass availability under conservative and optimistic scenarios relating to yield improvements over time. County-level terrestrial biomass supply curves,¹⁴ most recently updated in a 2011 resource assessment,¹⁵ will be updated as projections for technology improvements and underlying market conditions evolve. This information will be maintained in the Bioenergy Knowledge Discovery Framework (KDF), as discussed in Section 2.5.4.¹⁶

¹⁴ Modeling is based on county-level data provided by the USDA National Agricultural Statistics Service among other sources, hence outputs are provided at the county level. See De la Torre Ugarte and Ray (2000) for application of POLYSYS to biomass feedstocks.

¹⁵ U.S. Department of Energy. 2011. *U.S. Billion-Ton Update: Biomass Supply for a Bioenergy and Bioproducts Industry*. R.D. Perlack and B.J. Stokes (Leads), ORNL/TM-2011/224. Oak Ridge National Laboratory, Oak Ridge, TN. http://www1.eere.energy.gov/biomass/pdfs/billion_ton_update.pdf.

¹⁶ “Bioenergy Knowledge Discovery Framework,” U.S. Department of Energy, <http://www.bioenergykdf.net>.

Analysis also includes developing techno-economic assessments (TEAs) to help set goals and targets, as well as tracking the progress of R&D through state-of-technology (SOT) assessments of feedstock supply systems across specific feedstock/conversion technology pathway combinations. Attaining TEA targets requires working closely with researchers who are developing thermochemical and biochemical conversion processes to ensure that the delivered feedstock meets the conversion process material in-feed requirements, as well as tracking conversion and environmental performance. These activities also include risk assessments (strategic, economic, and operational risk) and incorporating those assessments into TEAs/LCA.

Terrestrial Biomass Production

The primary focus of feedstock production is developing and validating sustainable biomass production processes and systems to overcome biomass production barriers and provide information to producers that enable lignocellulosic feedstock production regionally. This is implemented through the DOE Sun Grant Regional Feedstock Partnership (“the Partnership”), which includes numerous land-grant universities, two national laboratories, and USDA-ARS researchers. The Partnership, dedicated to the assessment and sustainable production of terrestrial biomass in five Sun Grant regions, is establishing a productivity baseline for selected herbaceous energy crops, short-rotation woody crops, and agricultural residues through a series of multi-year, replicated field trials across wide geographical range. Selected trial sites for each crop being investigated are being used to collect environmental sustainability data, such as soil carbon, water use, and greenhouse gas emissions. The data from the field trials are also helping to support research on integrated landscape management strategies that integrate energy crop production with vegetative barriers to prevent soil and chemical runoff, and include cover crops in field management in environmentally sensitive areas to improve overall biomass yield while reducing environmental impacts.

The Office actively engages with USDA-, DOE Office of Science-, and ARPA-E-sponsored efforts in the areas of terrestrial crop variety improvement, crop genetics, genomics, and genetic engineering. The Office also monitors and coordinates the development of best management practices for energy cropping systems with USDA and with DOE’s Office of Science and ARPA-E to ensure their production efforts support the attainment of Office and national goals. Sustainable production of herbaceous and woody biomass for bioenergy will be the major focus at two BETO-sponsored workshops in Fiscal Year 2014.

Terrestrial Feedstock Logistics

Near-term R&D continues to focus on reducing conventional system costs, while developing and demonstrating strategies for increasing the volumes of feedstock that can meet quality and affordability criteria for a variety of biomass conversion processes.

Mid-term work focuses on meeting the cost, quality, and volume requirements associated with a growing biorefinery industry by developing and demonstrating strategies and technologies that address the limitations of conventional feedstock logistics technologies. This will involve designing, constructing, demonstrating, and validating field-scale equipment that (1) eliminates steps in the conventional process (for example, single-pass harvesting eliminates windrowing), (2) increases operational efficiencies and capacity, (3) employs preprocessing strategies capable of upgrading the quality and reducing the variability of harvested biomass, and, ultimately, (4)

lowers overall logistics costs. Also, Terrestrial FSL supports the research that expedites technology deployment by reducing or eliminating the need to develop entirely new equipment and systems. Purpose-designed equipment developed to supply the bioenergy industry will also stimulate the U.S. farm and forestry manufacturing sector and create jobs in urban and rural communities across the country.

Longer-term efforts focus on developing advanced preprocessing strategies and technologies that convert raw biomass into high-quality, infrastructure-compatible commodity feedstocks, while meeting conversion process in-feed specifications and balancing delivered feedstock costs against conversion performance characteristics to optimize overall process economics.

Conversion Interface

Feedback between Terrestrial FSL systems and conversion process performance is critical to developing an optimized feedstock supply chain. Conversion interface efforts correlate the effect of feedstock quality on conversion performance to define ranges of tolerable conversion process input specifications to attain required conversion targets. This area therefore develops and produces preprocessed feedstocks for testing in bench-scale conversion reactors for different pathways. As required, larger quantities of feedstock meeting conversion specifications are prepared for scaled-up testing of conversion process performance.

Specific ongoing activities include collecting, organizing, and archiving raw biomass samples; assessing chemical and physical properties (including after preprocessing operations); preparing feedstock materials for testing of conversion processes; compiling the resulting data into the Biomass R&D Library; and correlating those data sets to understand relationships among all performance parameters. The Biomass R&D Library includes three elements: physical sample cataloging and archiving, characterization of physical and chemical attributes of collected biomass samples, and a database in which all the characteristics of these samples are stored and made available to the research community and public. The Library database includes information on sample origin and treatments, related publications, and all data related to each raw or preprocessed biomass sample, enabling all subsequent analyses conducted on that sample to be linked to its source. The Library enables the understanding of the impact of feedstock variability on conversion process performance characteristics and biofuels production cost.

Demonstration Interface

Demonstration Interface activities extend development of the advanced processing strategy system outlined above to address feedstock supply and logistics systems at scales to meet the needs of integrated biorefinery operations. These efforts include the design, operation, and validation of advanced processing technologies and integrated supply chain components at demonstration scale.

Table 2-1: Terrestrial Feedstock R&D Activity Summary

WBS Element	Description	Barrier(s) Addressed
<p>Analysis and Sustainability</p>	<ul style="list-style-type: none"> - Resource assessment with projections of current and future potential domestic biomass resources by type and their geographic distribution at different price points; the quality attributes (e.g., moisture, ash, and carbon content) associated with those resources as a function of geography and price; and the environmental sustainability constraints associated with accessing those biomass resources over time. 	<p>Ft-A: Terrestrial Feedstock Availability and Cost Ft-B: Production Ft-C: Terrestrial Feedstock Genetics and Development Ft-D: Sustainable Harvesting Ft-E: Terrestrial Feedstock Quality and Monitoring Ft-F: Biomass Storage Systems Ft-G: Biomass Material Properties and Variability Ft-H: Biomass Physical State Alteration Ft-I: Biomass Material Handling and Transportation Ft-J: Overall Integration and Scale-Up Bt-B: Biomass and Feedstock Variability Bt-C: Biomass and Feedstock Recalcitrance Tt-A: Feeding Dry Biomass Tt-B: Feeding Wet Biomass Tt- C: Relationship between Feedstock Composition and Conversion Process Tt-F: Deconstruction of Biomass to Form Bio-Oil Intermediates Mm-A: Lack of Understanding of Environmental/Energy Tradeoffs Im-C: High Risk of Large Capital Investments Im-E: Cost of Production St-C: Sustainability Data across the Supply Chain St-E: Best Practices and Systems for Sustainable Bioenergy Production St-F: Systems Approach to Bioenergy Sustainability Im-A: Inadequate Supply Chain Infrastructure Comparable At-A: Transparent, and Reproducible Analyses At-B: Analytical Tools and Capabilities for System-Level Analysis At-C : Data Availability across the Supply Chain</p>
<p>Production</p>	<ul style="list-style-type: none"> - Develop, field test, and validate region-specific production systems for cellulosic feedstocks to increase yield and lower cost, as well as to analyze systemic impacts. - Address all operations, costs, and sustainability issues associated with site preparation, crop establishment, growth, and maintenance of terrestrial biomass crops up to the point of harvest and collection (in partnership with USDA). - Feedstock Characterization: Identify critical aspects of biomass and feedstock quality, including physical, chemical, and conversion performance characteristics, which can significantly impact downstream operations, including conversion process product yield and kinetics and process economics. 	<p>Ft-A: Terrestrial Feedstock Availability and Cost Ft-B: Production Ft-C: Terrestrial Feedstock Genetics and Development Ft-D: Sustainable Harvesting Ft-G: Biomass Material Properties and Variability Ft-J: Overall Integration and Scale-Up</p>
<p>Logistics</p>	<ul style="list-style-type: none"> - Identify the factors and their costs within each unit operation following harvest (drying, milling, densification, blending, etc.) that transforms the collected biomass into an acceptable feedstock for conversion. - Develop, test, and demonstrate sustainable cellulosic feedstock logistics systems. Physiochemical characterization of the biomass before and after preprocessing used to assess the magnitude of the preprocessing benefit. 	<p>Ft-A: Terrestrial Feedstock Availability and Cost Ft-B: Production Ft-E: Terrestrial Feedstock Quality and Monitoring Ft-F: Biomass Storage Systems Ft-G: Biomass Material Properties and Variability Ft-H: Biomass Physical State Alteration Ft-I: Biomass Material Handling and Transportation Ft-J: Overall Integration and Scale-Up</p>

Terrestrial Feedstock Supply and Logistics R&D

WBS Element	Description	Barrier(s) Addressed
Conversion Interface	- Identify key feedstock-based characteristics that affect conversion process yields and economics in collaboration with conversion research efforts.	Ft-A: Terrestrial Feedstock Availability and Cost Ft-C: Terrestrial Feedstock Genetics and Development Ft-G: Biomass Material Properties and Variability Ft-H: Biomass Physical State Alteration Ft-J: Overall Integration and Scale-Up Bt-B: Biomass and Feedstock Variability Bt-C: Biomass and Feedstock Recalcitrance Tt-A: Feeding Dry Biomass Tt-B: Feeding Wet Biomass Tt- C: Relationship between Feedstock Composition and Conversion Process Tt-F: Deconstruction of Biomass to Form Bio-Oil Intermediates
Demonstration Interface	- Systems-level validation of all key technologies to utilize biomass feedstocks in biorefineries	Ft-A: Terrestrial Feedstock Availability and Cost Ft-J: Overall Integration and Scale-Up Bt-K: Biochemical Conversion Process Integration Tt-A: Feeding Dry Biomass Tt-B: Feeding or Drying Wet Biomass Tt-R: Process Integration Im-A: Inadequate Supply Chain Infrastructure

2.1.1.5 Prioritizing Terrestrial Feedstock Supply and Logistics Research and Development Barriers

To achieve the Terrestrial FSL R&D goal of developing sustainable technologies that provide a secure, reliable, and affordable feedstock supply for the U.S. bioenergy industry, the challenges and barriers identified above need to be prioritized and addressed as funding permits. However, the following issues are considered most critical and will be emphasized within the program's efforts:

- Increase the volume of sustainable, acceptable-quality, cost-effective feedstock available to biorefineries by developing advanced feedstock supply systems and strategies
- Incorporate sustainability and feedstock supply risk into the resource assessments
- Work with conversion technology areas to understand the range of acceptable physical and chemical in-feed specifications for the various conversion technologies
- Develop high-capacity, high-efficiency, low-cost, commercial-scale feedstock supply and logistics systems that deliver stable, dense, flowable, consistent-quality, infrastructure-compatible feedstock.¹⁷

In the past, Office-funded Terrestrial FSL research focused on modifying conventional terrestrial feedstock logistics systems that were designed and manufactured for traditional agricultural and forestry industries. Conventional systems are suitable for high biomass-yielding regions, but not for medium-to-low-yield areas. Supplying feedstock to a growing bioenergy industry requires increasing the accessible volumes of lignocellulosic feedstock, while increasing the emphasis on quality, as well as reducing variability and risk. One approach to achieving this is applying preprocessing techniques, such as blending.¹⁸

Quality targets have large impacts on whether or not a particular feedstock is cost effective in the context of a particular conversion process, as well as how much material is available for conversion. As an example, the inherent variability of one aspect of biomass quality, namely ash, for Midwestern corn stover is illustrated in Figure 2-8.¹⁹

¹⁷ Note that Section 2.1.1.2 lists fewer milestones between the years 2017 and 2022. Terrestrial FSL has the strategic goals listed in that section; however, more specific milestones during out years will be determined once some initial research is conducted through 2017.

¹⁸ Kenney et al. 2013. "Feedstock Supply System Design and Economics for Conversion of Lignocellulosic Biomass to Hydrocarbon Fuels-Conversion pathway: biological conversion of sugars to hydrocarbons." INL/EXT-13-30342. <https://inlportal.inl.gov/portal/server.pt?open=512&objID=421&parentname=CommunityPage&parentid=4&mode=2>.

¹⁹ For a more in-depth discussion of biomass variability, see K. Kenney, W. Smith, G. Gresham, T. Westover. 2013. Understanding Biomass Feedstock Variability. *Biofuels* 4(1).

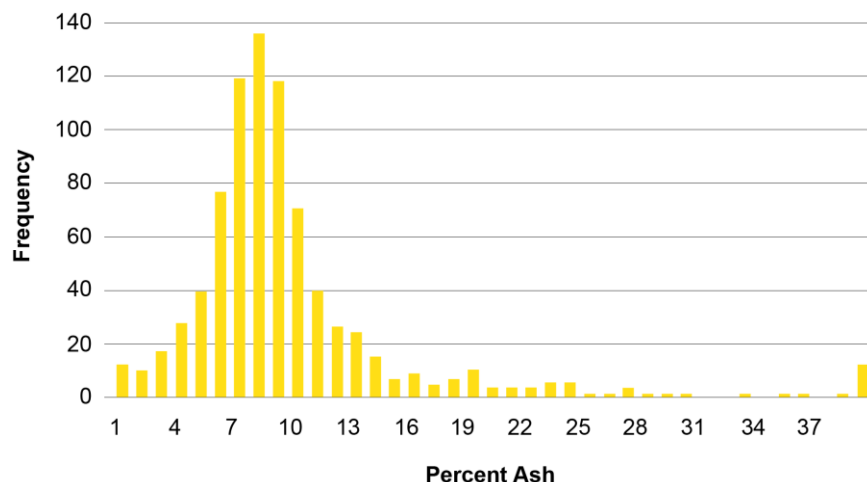

Figure 2-8: Example of the variability of corn stover characteristics such as percent total ash content²⁰

Ash is the inorganic or mineral content of biomass, and biomass ash content varies considerably among and within biomass materials types. Understanding biomass ash content, variability, and where it originates requires differentiation of the sources of ash, which include structural ash associated with the plant cell walls, vascular ash in the plant, and introduced ash resulting from soil contamination. Ash cannot be converted to a biofuel product and causes operational problems in downstream conversion processes, including increased equipment wear, quenching of catalysts, increased corrosivity and instability of pyrolysis oils, slagging and fouling in thermochemical equipment, and costs associated with ash disposal. Also, the proportion of convertible biomass content decreases with increasing ash content, effectively increasing the cost per dry ton of feedstocks. Even though it is unlikely any single conversion technology will be capable of handling the full range of biomass variability, the variability of biomass quality necessitates the development of more robust biofuel conversion technologies.

By combining analyses using biomass price projections with quality information obtained from the Biomass R&D Library, gains in the projected volumes available at cost and biorefinery specifications can be realized by transitioning to a blended feedstock approach. Figure 2-9—projected supply curves for terrestrial biomass in 2022—shows a step-wise supply curve that indicates increased cellulosic feedstock supplies in the market with increasing farmgate prices between \$20 and \$200 per dry ton, marginal price, and average price²¹ (white line). The average price is less than the nominal price for a single feedstock.

²⁰ Data was extracted from the Biomass R&D Library. The data set includes 840 samples, including corn stover, miscanthus, and wheat straw.

²¹ For the purpose of this study, farmgate price is defined as the price needed for biomass producers to supply biomass to the roadside. It includes, when appropriate, the planting, maintenance (e.g., fertilization, weed control, pest management), harvest, and transport of biomass in the form of bales or chips (or other appropriate forms—e.g., billets, bundles) to the farmgate or forest landing. The term “marginal price” is used in biomass supply analysis to convey the price needed to supply an additional ton of biomass to either the farmgate, forest landing, biomass depot, or conversion facility. “Average price” is used in biomass supply analysis to convey the average price to acquire a stream of biomass, from the first to the last ton, over a specific period of time.

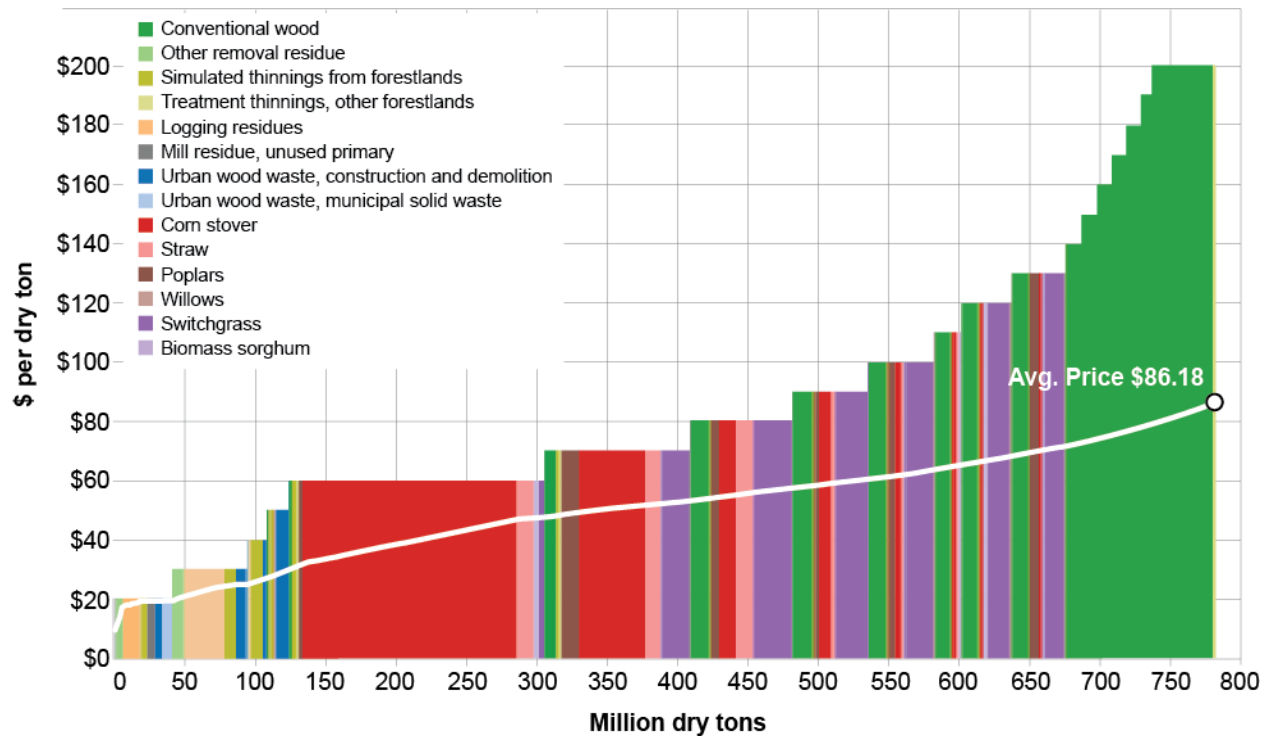

Figure 2-9: Biomass supply projections at marginal prices between \$20 and \$200/dry ton in 2022

Feedstock blending allows a biorefinery to collect less of any one feedstock and thus move down the cost versus supply curve, enabling biorefineries to pay a lower average price. Note that this does not change the supply versus cost curves for each resource, but it instead describes a system where purchasers are using a combination of least-cost resources and blending them to reach the biorefinery’s desired cost and quality specifications.²²

Formulating a designed feedstock through blending and other preprocessing methods allows low-cost and typically low-quality biomass to be blended with biomass of higher cost and typically higher quality to achieve the specifications required at the in-feed of a conversion facility. The use of low-cost biomass allows the supply chain to implement additional preprocessing technologies that actively control feedstock quality, while also bringing more biomass into the system. This analysis and design approach is referred to as the “least-cost formulation” strategy.

Using a least-cost formulation analysis, Table 2-2 illustrates that modeled feedstock cost and quality targets can be met for the bio-oil conversion pathway (fast pyrolysis). This pathway is currently designed for an ash content of less than 1% on a dry weight basis.²³ In the example, low-cost, low-quality logging residues; switchgrass; and construction and demolition (C&D)

²² Dave Muth, Jacob J. Jacobson, Kara Cafferty, Robert Jeffers. “Define feedstock baseline scenario and assumptions for the \$80/DT target based on INL design report and feedstock logistics projects.” ID#: 1.6.1.2.DL.4, 11.2.4.2.A.DL.2. Joule, WBS #: 1.6.1.2/11.2.4.2, Completion Date: 3/31/13, INL/EXT-14-31569.

²³ Jones et al. 2013. Process Design and Economics for the Conversion of Lignocellulosic Biomass to Hydrocarbon Fuels: fast pyrolysis and hydrotreating bio-oil pathway. PNNL-23053, NREL/TP-5100-61178. http://www.pnnl.gov/main/publications/external/technical_reports/PNNL-23053.pdf.

waste are processed and blended with higher-cost, higher-quality debarked pine chips to meet conversion specifications. The exact quantity of each feedstock depends on the cost and characteristics of the individual feedstocks, as well as the target in-feed requirements. The modeled formulation uses 45% purpose-grown pine, 32% residues, 3% switchgrass, and 20% C&D waste as an example of this least-cost formulation strategy to obtain feedstocks that have an average delivered cost of \$80/dry ton and cumulative ash content below 1% on a dry weight basis.

Table 2-2: Example of Modeled Costs and Specifications for Processed Woody Feedstocks and Blends for Fast Pyrolysis and Subsequent Upgrading to a Hydrocarbon Fuel

Feedstock	Modeled Total Feedstock Cost* to Reactor Throat (\$/dry ton)	Formulation Fraction (%)	Ash Content at Reactor Throat ²⁴
Purpose-Grown Pine (Wood)	99.49	45	0.5
Logging Residues ²⁵	67.51	32	1.0
Switchgrass	66.68	3	4.0
C&D Waste	58.12	20	1.0
Delivered Formulation Totals	80.00	100	<1.0%

*Includes grower payment and logistics costs

Modeled costs for forest thinnings and logging residues are estimated using supply chains that incorporate technologies and strategies that are currently under development, such as an innovative ash-reduction unit operation, at costs below the \$80/dry ton target. While the 45% fraction of debarked purpose-grown pine in Table 2-2 exceeds the \$80/dry ton cost target (at a modeled cost of nearly \$100/dry ton), it provides very low-ash material that helps the feedstock meet the thermochemical conversion quality specifications. When blended, the formulation meets both the cost and feedstock quality targets. Moving beyond 2017, the blending strategy will allow even more resources to be made economical and of appropriate quality for bioenergy production, while still hitting the \$80/dry ton cost target.

Prior to the transition to advanced systems that incorporate concepts such as blending, Terrestrial FSL research was focused on improving conventional systems. Through 2012, conventional woody supply system costs were reduced by improving existing equipment efficiencies, adopting innovative ways of mitigating moisture content, and increasing grinder performance. The cost target of \$46.37/dry ton (2007\$, excluding grower payment) was achieved in 2012,²⁶ supporting

²⁴ Note that Table 2-2 is intended as a demonstration of the blending concept and is not intended to represent future quality targets for ash. Values for pulpwood, residues, and C&D from: E. Lindstr. m, S. Larsson, D. Boström, M. Ohman. 2010. Slagging Characteristics during Combustion of Woody Biomass Pellets Made from a Range of Different Forestry Assortments. *Energy & Fuels* 24(6); Switchgrass value extracted from Turn, S.Q., C.M. Kinoshita, and D.M. Ishimura. 1997. Removal of inorganic constituents of biomass feedstocks by mechanical dewatering and leaching. *Biomass and Bioenergy* 12(4).

²⁵ For the purposes of this analysis, residue costs do not include harvest and collection, as they are moved to the landing while attached to the merchantable portion of the tree.

²⁶ E. Searcy, J. Hess, C. Wright, K. Kenney, J. Jacobson. "State of Technology Assessment of Costs of Southern Pine for FY10 Gasification," October 2010, INL/LTD-10-20306.

Office goals at the time. The year 2013 marked the transition from conventional feedstock supply systems to advanced systems and non-ideal feedstock supply areas, based on the desire to increase the total volume of material that can be processed and enable more biorefinery options, to address quality, and to meet the 2017 cost target of \$80/dry ton delivered to the throat of the biorefinery, including grower payment. Moving beyond 2017, advanced systems will gradually bring in larger quantities of feedstock from an even broader resource base, as well as incorporate environmental impact criteria into availability determinations. Feedstock supplied after 2017 will continue to meet the \$80/dry ton cost target and quality requirements of various conversion processes.

Figure 2-10 and Table 2-3 show potential reductions in the delivered feedstock costs from 2013 through 2019 for a fast pyrolysis conversion process.

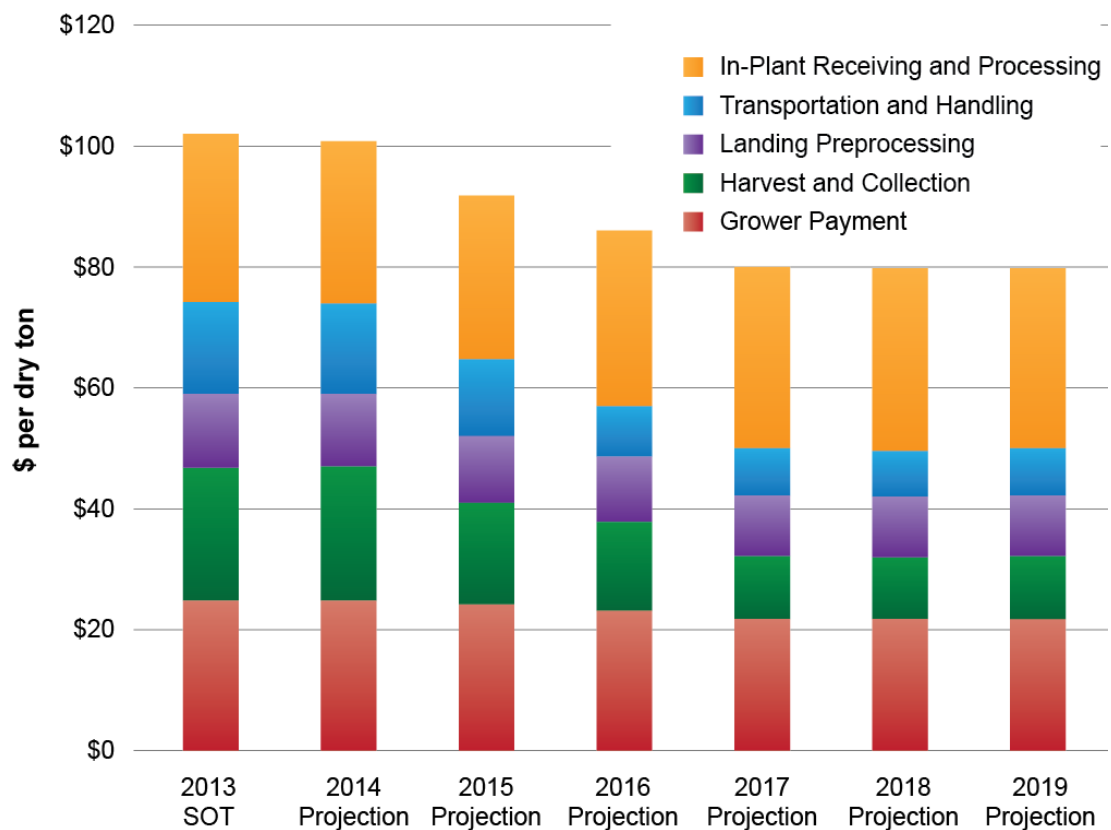

Figure 2-10: Historical and projected delivered feedstock costs, modeled for pyrolysis conversion

Total modeled feedstock cost decreases through 2017 as the result of capacity and efficiency improvements, innovative design strategies (such as blending), novel preprocessing approaches, and integrated landscape management strategies. For example, blending reduces the harvest and collection cost. The 2013 SOT is based on purpose-grown trees, which incur a harvest and collection cost. Harvest and collection costs associated with residues, however, are allocated to the cash crop, such as timber or pulpwood. Switchgrass has a lower harvest and collection cost than purpose-grown wood, and C&D waste does not have a harvest cost. Therefore, blending these materials will result in a decreased harvest and collection cost. Note that the modeled costs

do not decrease between the years 2017 and 2019; however, the volume of biomass available at the \$80/dry ton target increases (Figure 2-10).²⁷

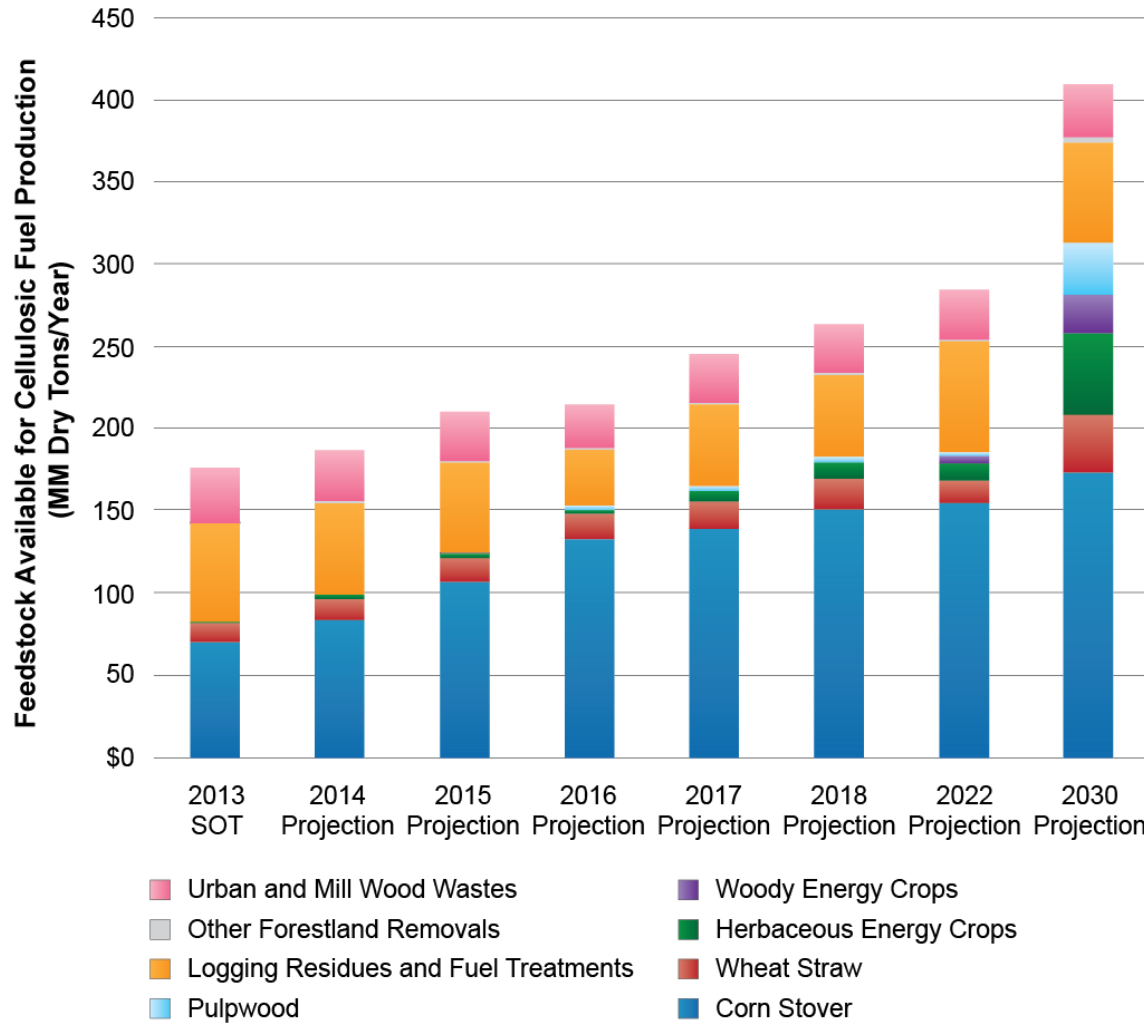

Figure 2-11: Historical and projected volumes of biomass available at a delivered cost of \$80/dry ton for various biomass types, accommodating multiple conversion processes.

Note that the higher volumes in Figure 2-11 are due to a variety of factors, including increased biomass yields, capacity and efficiency improvements in logistics systems, and innovative logistics strategies, such as blending. Table 2-3 shows a reduction in grower payment of just more than \$3/dry ton from 2013 to 2019, while concurrently increasing biomass resources available.

²⁷ See Table B-1 in Appendix B.

Table 2-3: Feedstock Logistics Costs for Feedstock for a Pyrolysis Conversion Process²⁸

2011 Dollars	2013 SOT	2014 Projection	2015 Projection	2016 Projection	2017 Projection	2018 Projection	2019 Projection
Feedstock Type	Pine	Pine	Blend	Blend	Blend	Blend	Blend
Total Delivered Cost \$/dry ton	\$102.12	\$101.45	\$92.36	\$86.72	\$80.00	\$80.00	\$80.00
Grower Payment \$/dry ton	\$25.00	\$25.00	\$24.43	\$23.45	\$21.90	\$21.90	\$21.90
Total Feedstock Logistics \$/dry ton	\$77.12	\$76.45	\$67.93	\$63.27	\$58.10	\$58.10	\$58.10
Harvest and Collection	\$22.24	\$22.24	\$16.68	\$14.46	\$10.47	\$10.47	\$10.47
Landing Preprocessing	\$12.17	\$12.17	\$11.37	\$11.02	\$10.24	\$10.24	\$10.24
Transportation and Handling	\$14.84	\$14.84	\$12.47	\$8.48	\$7.52	\$7.52	\$7.52
In-Plant Receiving and Processing	\$27.87	\$27.20	\$27.41	\$29.31	\$29.87	\$29.87	\$29.87
Total Feedstock Logistics \$/gal total fuel	\$0.88	\$0.87	\$0.77	\$0.72	\$0.66	\$0.66	\$0.66
Harvest and Collection	\$0.25	\$0.25	\$0.19	\$0.16	\$0.12	\$0.12	\$0.12
Landing Preprocessing	\$0.14	\$0.14	\$0.13	\$0.13	\$0.12	\$0.12	\$0.12
Transportation and Handling	\$0.17	\$0.17	\$0.14	\$0.10	\$0.09	\$0.09	\$0.09
In-Plant Receiving and Processing	\$0.32	\$0.31	\$0.31	\$0.33	\$0.34	\$0.34	\$0.34
Gallons total fuel/dry ton	88	88	88	88	88	88	88

Preliminary results suggest that blending multiple preprocessed feedstocks enables the acquisition of higher biomass volumes and reduces feedstock variability to meet biorefinery in-feed specifications, while delivering feedstock to the biorefinery at \$80/dry ton. Research is needed on blending strategies; on the performance of blended material; and on other advanced design technologies to meet cost, quality, and volume targets.

One metric that is used to assess sustainability of logistics systems is greenhouse gas emissions. A greenhouse gas emissions assessment was conducted on the 2013 SOT shown in Table 2-3. The assessment included process inputs, fuels (diesel, natural gas), and electricity for all operations from harvest through reactor in-feed.²⁹ The total greenhouse gas emissions from logistics was found to be 230 kg CO₂e/dry ton.

2.1.1.6 Terrestrial Feedstock Supply and Logistics Research and Development Milestones and Decision Points

The key Terrestrial FSL program milestones, inputs/outputs, and decision points to complete the tasks described in Section 2.1.4 are summarized in Figure 2-12.

²⁸ Note that the grower payment for 2017 projection is the weighted average associated with a blend scenario. Growers payment includes harvest, collection, and landing preprocessing costs, but these costs are also reflected in the feedstock logistics cost to demonstrate all logistics components.

²⁹ Biomass production inputs, such as fertilizer, and greenhouse gases associated with feedstock conversion were not included.

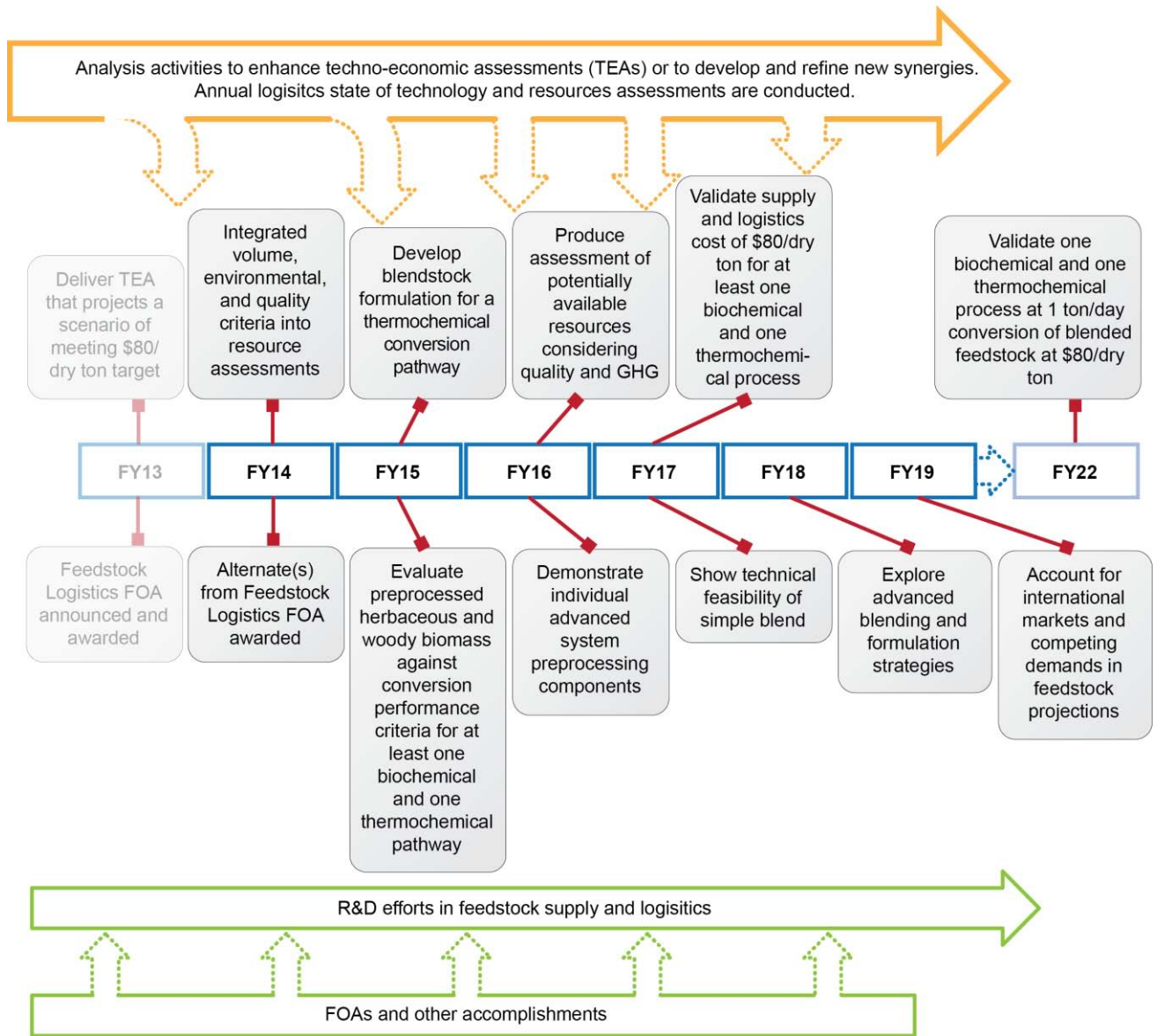

Figure 2-12: Terrestrial feedstock supply and logistics R&D key milestones and activities

2.1.2 Algal Feedstocks Research and Development

Biofuel intermediate feedstocks derived from algal biomass can contribute significantly to expanding the domestic, advanced biofuel resource potential. This is based on the potential for the high productivity of algae while using non-arable land, brackish water, or salt water, and on the possibility of using waste nutrients and effluents. Also, due to the ability of algae to accumulate significant amounts of lipids, algae can be particularly well-suited for conversion to hydrocarbon-based fuels, such as renewable diesel and jet.

Algal Feedstocks R&D focuses on overcoming technical barriers to the cost-effective production of algal biomass and intermediates, as well as on developing logistics systems for producing commercially viable algae-based biofuels and bioproducts. Algal biomass includes micro- and macro-algae, as well as cyanobacteria. These efforts are broadly classified into algal biomass production, which includes development of algae strains, and development of algae cultivation systems (e.g., open-pond and closed photobioreactor systems) able to cost-effectively produce commercial levels of algal biofuels and bioproducts.

Developing algal feedstocks to achieve advanced biofuel goals requires breakthroughs along the entire algal biomass value chain. Algal Feedstocks R&D focuses on demonstrating progress toward achieving high-yield, low-cost, environmentally sustainable algal biomass production and logistics systems that produce biofuel intermediate feedstocks that are well-suited for conversion to fuels and other valuable products.

Algal Biofuel Intermediate Supply System

The conceptual flow diagram in Figure 2-13 outlines the main elements of a generic algae supply and logistics system to provide biofuel intermediate feedstocks suitable for conversion to advanced biofuels. This diagram represents many—but not all—possible algae systems and describes the design basis used to establish cost projections. A range of alternative systems are discussed in the *National Algal Biofuels Technology Roadmap*.³⁰ The conceptual diagram in Figure 2-13 establishes a common baseline to communicate the relationship of system components and provide a basis for consideration of alternative and innovative processes and methods to achieve the cost goals needed for commercial applications.

This generic model of the algal biofuel intermediate supply system is based on literature and bench-scale and development unit efforts undertaken since 2009. Uniform specifications have not been established and will require a harmonized approach to integrating resource assessment, life-cycle analysis, technoeconomics, and close coordination with conversion areas. Much of the analysis around algal biomass is in early stages of development, and significant refinements are expected as R&D investments mature.

³⁰ U.S. Department of Energy, *National Algal Biofuels Technology Roadmap* (2010), Washington: Government Printing Office, http://www1.eere.energy.gov/biomass/pdfs/algal_biofuels_roadmap.pdf.

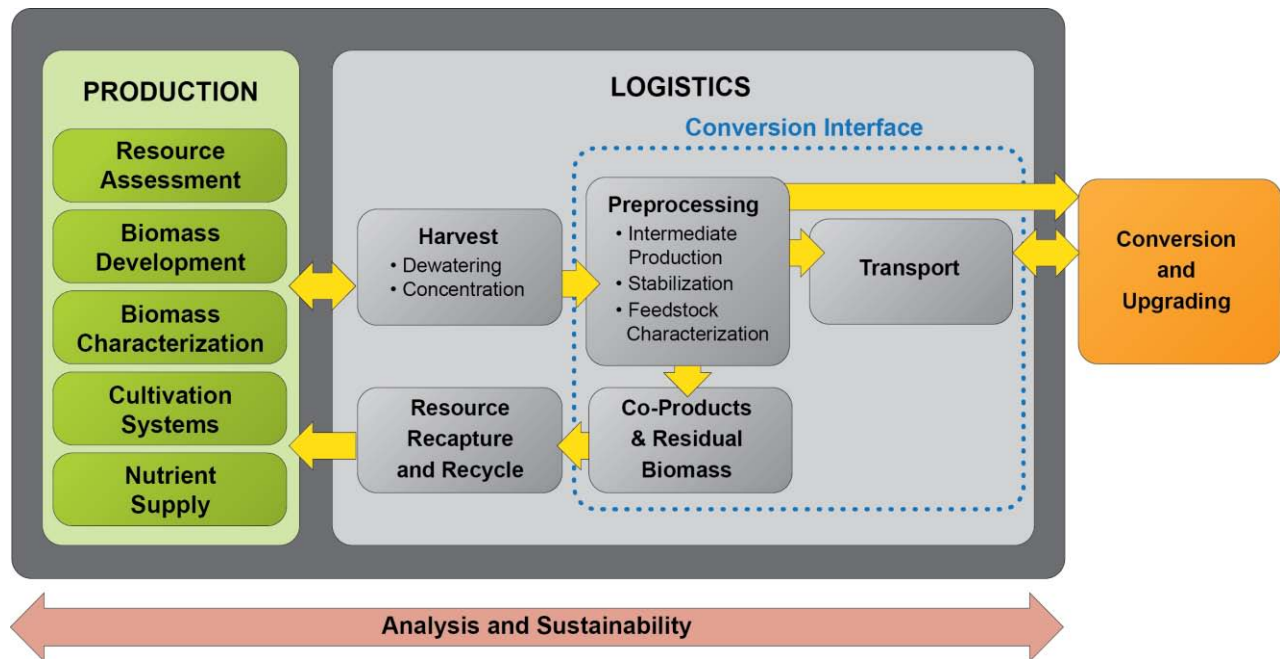

Figure 2-13: Generic algal biofuel intermediate feedstock supply and logistics flow diagram

Production: The production component of the supply system includes both resource assessment and technology development. Production technology development focuses on algal biomass development and characterization, cultivation system technologies, and nutrient supply systems.

Resource Assessment: Resources necessary to operate sustainable algal systems include sufficient solar resource, non-arable land, non-potable water, waste-nutrient streams, waste CO₂, and supporting transport infrastructure to access downstream conversion processing. Development of an algal biofuel industry requires scaling-up from hundreds of acres currently in domestic algae cultivation to millions of acres. Algae resource assessment activities include (1) identification of potential geographic locations for algae farms based on resource access and availability, (2) cost estimates for current and future resources, and (3) the environmental sustainability of the use of these resources.

Biomass Development: Algal biomass includes micro- and macro-algae, as well as cyanobacteria. Biomass development activities include (1) strain prospecting and isolation to identify types of algae with desirable growth properties, and (2) investigation of potential biological improvements from breeding, modification, and genetic engineering. Systems biology approaches to improve advantageous traits for production are also part of biomass development.

Biomass Characterization: Biomass characterization includes understanding the fundamental components (lipids, starches, and proteins) of algal biomass and correlating those characteristics to favorable production of biofuels and bioproducts. Understanding the biomass characteristics of algae with confidence at different time points in the growth cycle is critical in developing cultivation management strategies, downstream processes, and ultimate product valuations.

Cultivation Systems: Algae cultivation systems include—but are not limited to—open mixed ponds, attached growth systems, and closed photobioreactors. Cultivation systems must optimize resource supply, materials cost, and operability while maximizing productivity. Cultivation strategies include crop protection, integration of co- or polycultures, water and nutrient management, light optimization, temperature management, and seasonal succession.

Nutrient Supply: Nutrient supply encompasses feeding algae both micro and macro nutrients, as well as CO₂ and recycled water necessary for their growth.

Logistics: The downstream processing of cultivated algal biomass takes place in the logistics components of the system, which include harvest, preprocessing, and transport of processed biofuel intermediates to the conversion facility. Logistics also encompasses co-products and residual processing, as well as resource recapture and recycle.

Harvest: Optimizing harvesting operations is critical to maximizing algal biomass yields while ensuring sustainability of the production system. Algal biomass can be harvested continuously or in daily or weekly batches. Harvest timing throughout the growth cycle may affect composition and structural features of the harvested algae. Water remaining after the algae are harvested must be recycled back into the cultivation system to minimize resource use. Macroalgae and attached growth systems that cultivate multicellular algae require a lower dewatering intensity.

Dewatering: Microalgae and cyanobacteria cultivated in water grow at dilute concentrations, with assumed solids at harvest typically ranging from 0.1 grams/liter to 4.0 grams/liter. Dewatering technology—such as those used in wastewater treatment processes and the mining industry—isolates solids from high-volume, low-concentration effluents.

Concentration: Dewatered algal biomass may still be too dilute for effective preprocessing; it will require further concentration to boost algal biomass slurry concentrations to at least 15%–20% solids to be efficiently preprocessed, with the final target to be dictated by the preprocessing interface. Centrifugation or membranes are typically used for concentrating the solids.

Preprocessing: The preprocessing of algae refers to the on-farm production of transportable intermediate products from the harvested algal biomass. Algal biofuel intermediates should be energy-dense and compatible with existing handling, transport, and storage infrastructure. Preprocessing may improve algal biomass for long-term storage, handling, and transport, as well as prepare the raw material for efficient conversion. A path for algae to bypass transportation represents routes where biochemical and/or thermochemical conversion reactions are utilized in the production of a biofuel intermediate, such as treatment with enzymes or hydrothermal liquefaction. Algal feedstock preprocessing steps may include the following:

Intermediate Production: Intermediate production is defined as the deconstruction and/or preprocessing of algal biomass into products such as extracted lipids, lipid-

extracted biomass, or hydrothermal liquefaction oil. Maximizing throughput and efficiency while producing both energy-dense biofuel intermediates and useful remaining biomass are key objectives for intermediate production technology. Regardless of which technology is used, the interface between feedstock characterization and downstream product requirements will play a role in determining appropriate intermediate production technology (e.g., a biofuel process requiring neutral lipids will need an intermediate stream of polar solvent extracted lipids). Thermal processing of whole algae, such as through hydrothermal liquefaction, is discussed in more detail in Section 2.2.2. under Thermochemical Conversion Research and Development.

Stabilization: The stability of intermediate products is an important consideration, particularly when the biofuel intermediate is transported offsite to a refinery for further upgrading. Methods of stabilization and storage may also have significant impacts on co-product generation.

Feedstock Characterization: The impact of preprocessing operations and reaction conditions on the resulting product streams has important implications for conversion and upgrading, as well as co-products. Methods to characterize these streams and develop predictive models of reaction kinetics will enable robust integrated process development.

Transportation: Algal biofuel intermediate products may be transported using existing transportation infrastructure. This provides some advantages to using lower-cost methods, such as rail, but it also provides a number of challenges that still need to be addressed, such as local codes, standards, and U.S. Department of Transportation regulations. In addition, longer-term implementation may require specific handling or materials of construction to avoid contamination or fermentation. As with the transportation of other biomass and feedstocks, these transportation details must be further investigated as more processes and intermediates are developed.

Co-Products and Residual Processing: The algae components that will not be directly converted to advanced biofuels can comprise 40%–75% of the biomass moving through the logistics system. Processing this residual biomass can provide nutrients and power back to the production and logistics systems. Components of algal biomass not sent for conversion to biofuel or not recaptured for reuse in cultivation may be converted to valuable co-products, such as animal feeds, commodity chemicals, or other products.

Resource Recapture and Recycle: Recycling residual salts and organic material remaining after preprocessing and/or residual processing enables the recapture of valuable nitrogen, phosphorus, other minor nutrients, and carbon that can displace the need for fresh fertilizer inputs upstream in cultivation and reduce the potential for buildup of inhibitory compounds within the cultivation system. Life-cycle analyses results suggest that the recapture of nitrogen in particular is a critical component of a favorable GHG emissions profile for algal biofuels.

Conversion Interface: The production of clean, energy-dense, stable, and transportable intermediates suitable for biofuel refining is inherently integrated with work conducted by the Conversion R&D and Demonstration and Deployment (D&D) Technology Areas. The Algal Feedstocks Technology Area coordinates with these areas on R&D of preprocessing, transportation, co-products, and direct conversion of algal feedstocks to finished fuels.

Analysis and Sustainability: Algae Feedstocks R&D uses techno-economic analyses and life-cycle assessments to identify key parameters with the greatest impact on the sustainability of a fully integrated algae system. These analyses guide the management of RD&D projects and provide the rationale to down-select technologies that cannot achieve Office goals.

2.1.2.1 Algal Feedstocks Research and Development Support of Office Strategic Goals

The strategic goal of the Algal Feedstocks R&D Technology Area is *to develop algae production and logistics technologies that, if scaled-up and deployed, could support the production of 5 billion gallons per year of sustainable, reliable, and affordable algae-based advanced biofuels by 2030.*

The strategic goal directly addresses and supports production of algal feedstocks for use by all potential conversion pathways to both biofuels and bioproducts.

2.1.2.2 Algal Feedstocks Research and Development Support of Office Performance Goals

The performance goal for the Algal Feedstocks R&D Technology Area is as follows:

- Demonstrate technologies to produce sustainable algal biofuel intermediate feedstocks that perform reliably in conversion processes to yield renewable diesel, jet, and gasoline fuels in support of the Office's \$3/gasoline gallon equivalent (GGE) advanced biofuels goal by 2022.

The Office has established two initial algal biofuels priority technology pathways: (1) algal lipid extraction and upgrading and (2) whole algae hydrothermal liquefaction and upgrading. Design cases for these two pathways are described in Section 2.1.2.5 and highlight key challenges, provide a framework for prioritizing R&D, and track progress toward performance goals and milestones.

Each pathway assumes photoautotrophic cultivation of algal biomass in open raceway ponds. The pathways may differ in types of algae cultivated, as well as harvesting, preprocessing, conversion, and recycle/wastewater treatment operations. Alternative designs for innovative operations and additional products continue to be developed and evaluated, and they will be incorporated into the Office's strategic plans as they show promise.

Algal Feedstocks Research and Development Technology Milestones

Milestones in support of the Algal Feedstocks R&D performance goal are to evaluate the potential domestic supply of algal biomass through the following steps:

- By 2014, demonstrate at research scale algae yield of 1,500 gallons of equivalent biofuel intermediate per acre per year.
- By 2016, review integrated R&D approaches for high-yielding algal biofuel intermediates to evaluate potential approaches for achieving the 2018 and 2022 milestones.
- By 2017, model the sustainable supply of 1 million metric tonnes ash free dry weight (AFDW) cultivated algal biomass.
- By 2018, demonstrate at non-integrated process development unit scale algae yield of 2,500 gallons or equivalent of biofuel intermediate per acre per year.
- By 2022, model the sustainable supply of 20 million metric tonnes AFDW cultivated algal biomass.
- By 2022, demonstrate at non-integrated process development unit-scale algae yield of 5,000 gallons biofuel intermediate per acre per year in support of nth plant model \$3/GGE algal biofuels.
- By 2025, demonstrate at integrated process development unit-scale algal productivity of greater than 5,000 gallons biofuel intermediate per acre per year.
- By 2030, validate demonstration-scale production of algae-based biofuels at total production cost of \$3/GGE (2011\$), with or without co-products.

2.1.2.3 Algal Feedstocks Research and Development Technical Challenges and Barriers

Algae Production

Aft-A. Biomass Availability and Cost: The lack of credible data on potential price, location, seasonality, environmental sustainability, quality, and quantity of available algal biomass feedstock creates uncertainty for investors and developers of emerging biorefinery technologies. Established biomass production history is required to assure investors and other funding sources that the feedstock supply risk is sufficiently low. Reliable, consistent, and sustainable biomass supply is needed to reduce financial, technical, and operational risk to a biorefinery and its financial partners.

Aft-B. Sustainable Algae Production: Existing data on the productivity and environmental effects of algae production and biomass collection systems are not adequate to support life-cycle analysis of biorefinery systems. A number of sustainability questions (e.g., water and fertilizer inputs, land conversion, and liner use) have not been comprehensively addressed. New production technologies for algae are also required to address cost, productivity, and sustainability issues.

Aft-C. Biomass Genetics and Development: The productivity and robustness of algae strains against perturbations such as temperature, seasonality, predation, and competition, could be improved by selection, screening, breeding, biologically mixed cultures, and/or genetic engineering. This will require extensive ecological, genetic, and biochemical information, which is currently lacking for most algal species. Any genetically modified organisms deployed commercially will also require regulatory approval by the appropriate federal, state, and local government agencies.

Algal Feedstocks Logistics

Aft-D. Sustainable Harvesting: Current algal biomass harvesting and dewatering technologies are costly and energy- and resource-intensive. Microalgae grown in liquid suspension are dilute (0.1–0.5 grams per liter) and require multiple concentration steps to yield a harvested biomass that can be processed. While dewatering technology exists in wastewater treatment processes and the mining industry to isolate solids from high-volume, low-concentration effluents, these existing technologies may be too energy-, capital-, and reagent-intensive for the development of algal biofuels.

Aft-E. Algal Biomass Characterization, Quality, and Monitoring: Physical, chemical, biological, and post-harvest physiological variations in harvested algae are not well researched or understood. The fundamental components (lipids, starches, and proteins) of algal biomass vary greatly, both among strains and in comparison to plants. A better understanding of the effects of wide variability in feedstock characteristics on biorefinery operations and performance is needed. Standard procedures to reliably and reproducibly quantify biomass components from algae and close-mass balances are not readily available—a significant challenge as compared to traditional plant-based biomass.

Aft-F. Algae Storage Systems: Characterization and analysis of different algae storage methods and strategies are needed to better define storage requirements; these storage methods should preserve harvested algal biomass and maintain its potential product yield over time.

Aft-G Algal Feedstock Material Properties: Data on algal feedstock quality and physical property characteristics in relation to conversion process performance characteristics are extremely limited. Methods and instruments for measuring physical, chemical, and biomechanical properties of biomass are lacking.

Aft-H. Overall Integration and Scale-Up: Integration of co-located inoculation, cultivation, primary harvest, concentration, and preprocessing systems is an expensive and challenging endeavor requiring interdisciplinary expertise. In addition, the potential for co-location with other related bioenergy technologies to improve balance of plant costs and logistics has not been evaluated to determine what cost savings could be achieved.

Aft-I. Algal Feedstock Preprocessing: After cultivation and harvesting of algal feedstocks, algal biomass may require processing or fractionation into lipids, bio-oils, carbohydrates, and/or proteins before these individual components can be converted into the desired fuel and/or products. Current technologies for algal fractionation and product extraction are not commercial. Process options for commercial scale-up have been identified and are being researched (e.g., conversion of whole algal biomass via thermal liquefaction), but few data exist on the cost, sustainability, and efficiency of these processes.

Aft-J. Resource Recapture and Recycle: Residual materials remaining after preprocessing and/or residual processing may contain valuable nitrogen, phosphorus, other minor nutrients, and carbon that can displace the need for fresh fertilizer inputs in upstream cultivation. The recapture of these resources from harvest and logistics process waste streams may pose separation challenges, and the recovered materials may not be in biologically available chemical forms. In closed-loop systems, the potential for buildup of inhibitory compounds also exists.

2.1.2.4 Algal Feedstocks Research and Development Approach for Overcoming Challenges and Barriers

The Algal Feedstocks R&D approach for overcoming the key challenges and barriers described above is outlined in its work breakdown structure (WBS), organized around five elements, as shown in Figure 2-14 and further summarized in Table 2-4. R&D activities are performed by national laboratories, universities, industry, consortia, and a variety of state and regional partners.

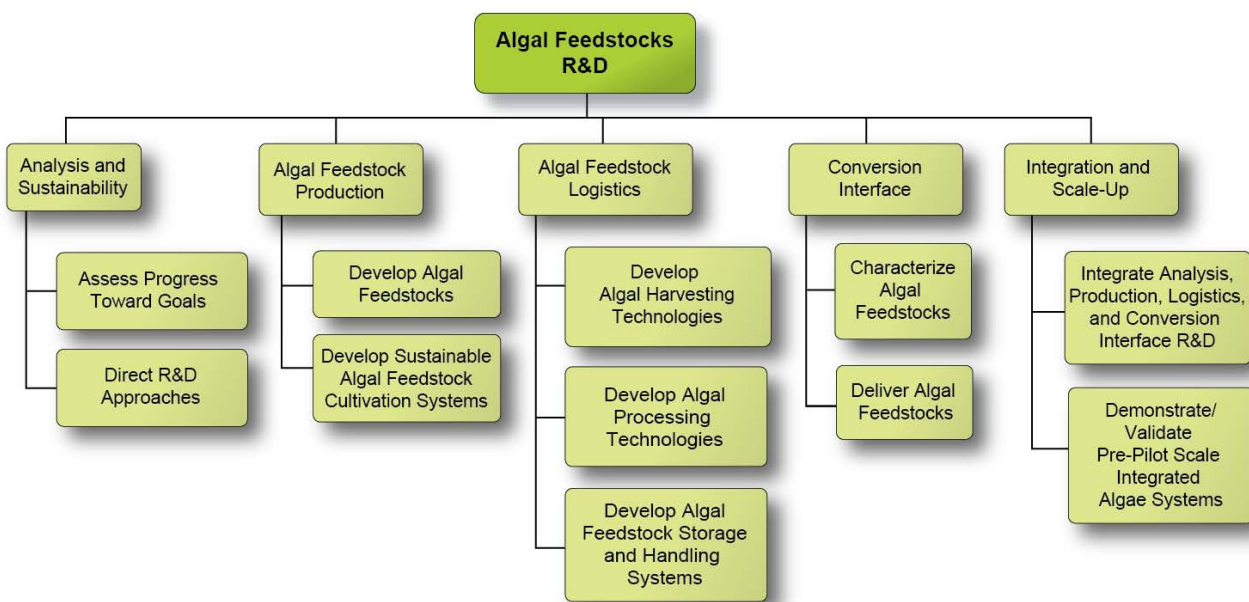

Figure 2-14: Algal feedstocks R&D work breakdown structure

Analysis and Sustainability

The primary work within the analysis and sustainability element focuses on assessing progress toward technical targets and cost goals and guiding the direction of R&D. Resource assessment is a second key area that includes establishing an inventory of national feedstock resource potential and assessing environmentally sustainable feedstock availability now and in the future. Planned R&D analysis activities for algal feedstock and processing systems include techno-economic and life-cycle analyses for multiple algal biomass production and processing scenarios.

Algal Biomass Production Research and Development

The primary focus of algal biomass production R&D is enabling the sustainable production of algae-derived biofuels by developing abundant, cost-effective, and sustainable algal biomass supplies in the United States. Algal Feedstocks R&D focuses on two main areas: algal feedstock development and cultivation systems development. Algal feedstock development focuses on developing stable algal strains that produce high yields, resist predators, and are suitable for cultivation in large-scale algal biofuel feedstock farming operations. Cultivation systems development focuses on developing materials, systems, and strategies to sustainably grow algal biomass suitable for downstream conversion.

Algal Feedstock Logistics Research and Development

The primary algal feedstock logistics R&D focus is to develop, test, and demonstrate technologies for the harvesting and processing of cultivated algae to create biomass feedstocks suitable for conversion to biofuels. Algal feedstock logistics focuses on three main areas: algae harvesting, harvested algae processing, and processed algae stabilization and transport.

Conversion Interface Research and Development

The conversion interface element aims to identify key algal feedstock characteristics and standards for downstream conversion processes. A unique aspect of the conversion interface is the extent to which feedstock processing and biofuel conversion technologies, such as extraction or hydrothermal liquefaction, are physically integrated with algae production. Efficient and effective linkage between algal feedstock and conversion processes is critical to facilitate the functioning of the entire value chain. The conversion interface area primarily addresses the effect of algae processing operations on conversion technology performance characteristics. These efforts will help to develop and optimize conversion process input specifications so that process economic targets can be achieved.

Integration and Scale-Up

Integration and scale-up is a particularly important aspect of algal feedstock production and logistics. It is recognized that high biomass productivities achievable in the laboratory do not always translate to success in outdoor environments due to ecological variables such as parasites, grazers, and pathogenic bacteria. A one-acre equivalent outdoor test environment is closely tied to laboratory bench-scale research as part of an iterative process whereby the results obtained from experiments in outdoor environments are used to inform the laboratory experiments and vice versa. This continuous feedback loop is expected to expedite lessons learned before scaling to larger pilot facilities.

The greatest impact for Algal Feedstocks R&D is in helping bridge the divide between laboratory and agricultural/industrial field operations by supporting applied research and process development. There are several components to bridging the divide, these include:

- Conducting research and development at the bench scale (approximately <100 liters of cultivation) and research and development integration at the 1 acre equivalent in parallel;
- Supporting replicated field trials at the smallest useful scale, approximately 1000 – 10,000 liter volumes under sunlight with natural temperature fluctuations.
- Integrating 1 acre equivalent operations, (approximately 400,000 – 800,000 liter culture volumes), as the minimum scale needed to gain insight into developing integrated processes for inoculation, growth, harvest and processing algal biomass; and
- Scaling to pilot operations, at a minimum scale of 10x process development (approximately 10,000,000 liters) and at a realized acre.

Due to the cost and complexity of scale-up, these R&D activities may ultimately be handed off to the Demonstration and Deployment Technology Area for construction of pilot and demonstration-scale facilities.

Table 2-4: Algal Feedstocks R&D Activity Summary

WBS Element	Description	Barrier(s) Addressed
Analysis and Sustainability	<p>Analyze availability, cost, and sustainability of algal feedstock production and logistics systems through development of techno-economic analysis and life-cycle analysis models and collection of life-cycle analysis and SOT data.</p> <ul style="list-style-type: none"> - Assess and quantify the geospatial volumetric supply potential of algal feedstocks and aggregate to national scale, incorporating technical, environmental, economic, and sustainability factors. Analyze factors that determine multiple and competing uses of algal feedstocks. - Analyze and model the performance of algal feedstock production and logistics systems. - Analyze impacts of algal feedstock production and logistics systems on human, animal and plant health, and biodiversity. 	<p>AfT-A: Biomass Availability and Cost AfT-B: Sustainable Production AfT-D: Sustainable Harvesting AfT-G: Feedstock Characterization, Quality, and Monitoring AfT-H: Storage Systems AfT-J: Material Properties AfT-M: Integration and Scale-Up AfT-N: Algal Feedstock Processing</p>
Production	<p>Develop productive and robust algal feedstocks, and develop, test, and demonstrate sustainable algal feedstock production systems.</p> <ul style="list-style-type: none"> - Develop algal germplasm and enable development of genetic technologies. - Explore and identify underlying biological phenomenon and traits in algae that convey desirable characteristics for large-scale cultivation. - Discover, breed, or engineer productive and robust algae strains for increased production scales and lower operational costs. - Develop laboratory tools and technologies to expedite the development of algal strains for large-scale cultivation. - Develop materials, systems, and strategies to utilize advanced algal feedstock development to sustainably grow algal biomass suitable for downstream conversion. - Develop, test, and demonstrate open, closed, hybrid, and/or offshore cultivation system technologies for improved productivity and reduced costs. - Develop technologies and management strategies for efficient use of system resource requirements, such as water, nutrients, CO₂, and light. - Integrate fundamental learning from community and systems ecology into cultivation design and practice to maximize productivity and resilience. 	<p>AfT-A: Biomass Availability and Cost AfT-B: Sustainable Production AfT-C: Feedstock Genetics and Development</p>
Logistics	<p>Develop, test, and demonstrate technologies for harvesting and processing cultivated algae.</p> <ul style="list-style-type: none"> - Develop, test, and demonstrate algal harvesting (dewatering) technologies with improved efficiency and reduced costs. - Develop, test, and demonstrate technologies that process algal biomass into products or intermediates through lysis, fractionation, extraction, and/or separation methods with improved efficiency and reduced costs. Investigate systems that integrate and/or circumvent these steps. - Develop, test, and demonstrate systems to store and handle whole and post-processed algal feedstocks with improved efficiency and reduced costs. 	<p>AfT-D: Sustainable Harvesting AfT-G: Feedstock Characterization, Quality, and Monitoring AfT-H: Storage Systems AfT-J: Material Properties AfT-M: Integration and Scale-Up AfT-N: Algal Feedstock Processing</p>
Conversion Interface	<p>Identify key algal feedstock characteristics and standards for downstream processes.</p> <ul style="list-style-type: none"> - Analyze multiple pre- and post-processed algal feedstocks and determine physical properties and chemical composition (lipids, carbohydrates, proteins, inorganics, and water) for efficient lipid upgrading, nutrient recycling, biochemical or thermochemical conversion, or transformation into bioproducts or biopower. - Investigate effects of feedstock characteristics in conversion experiments to develop an understanding of the correlation between feedstock preprocessing and conversion yields and selectivity. - Deliver feedstocks and feedstock measurement procedures for conversion R&D. 	<p>AfT-B: Sustainable Production AfT-J: Material Properties</p>
Integration and Scale-Up	<p>Conduct pre-pilot-level demonstration and validation of all key technologies to produce algal feedstocks for biofuels.</p> <ul style="list-style-type: none"> - Integrate algae production and logistics system technologies, identify system scale-up issues, and validate technoeconomics and environmental impacts at R&D scale. - Integrate algae production and logistics system technologies, identify system scale-up issues, and validate technoeconomics and environmental impacts at pre-pilot scale. 	<p>AfT-A: Biomass Availability and Cost AfT-B: Sustainable Production AfT-M: Overall Integration and Scale-Up</p>

2.1.2.5 Prioritizing Algal Feedstocks Research and Development Barriers

The key barriers to the development of algal feedstocks are the cost, quality, and volume of available biomass to supply the growing biobased industry for biofuels, bioproducts, and biopower. Design cases and accompanying state-of-technology reports are used to describe discreet barrier areas to achieving large volumes of low-cost, high-quality algal biofuel intermediates. Analysts use modeled scenarios, developed in close collaboration with researchers, to perform conceptual evaluations termed “design cases.” These design cases provide a detailed basis for understanding the potential of conversion technologies and help identify technical barriers where research and development could lead to significant cost improvements (please refer to Appendix C for a full definition of design cases). The following are critical emphasis areas identified as a result of these analyses:

- Developing biology and culture management approaches to unlock algal biomass productivity potential.
- Developing low-cost, scalable cultivation systems that maximize reliable annual yield and minimize water consumption, land use, and nutrient additions.
- Developing low-cost, high-throughput harvest technologies that can be integrated with cultivation systems.
- Performing integrative analysis to identify critical barriers and evaluate impacts on overall yield to developments in biology, cultivation, and processing.

Two initial priority pathways were selected by BETO as the most promising approaches to achieving the Algal Feedstocks R&D 2022 targets:

- Algal lipid extraction and upgrading
- Whole algae hydrothermal liquefaction and upgrading.

These analyses suggest that the highest cost to the system is biomass production; key sensitivities are productivity and lipid content, which can be represented as a single metric: biofuel intermediate yield per acre, per year. Other important areas are harvest efficiency, nutrient and water recycle, and processing efficiency, as well as capital costs of the production system. These technology pathway analyses are described in detail below.

Algal Lipid Upgrading Pathway (ALU)

Priority areas, technical targets, and accompanying cost projections for production of algal biomass that can be used as a biofuel intermediate via algal lipid extraction and upgrading were originally developed from sensitivities around the 2012 Harmonized Baseline,³¹ and then in the 2014 Algal Liquid Upgrading Design Case.³² The focus of the design case is to document a representative pathway model for conversion of algal carbohydrates and lipids to fuel and blendstock products, with high fractional energy yield to hydrocarbon products (e.g., renewable diesel) supplemented by additional energy yield to ethanol as a representative fermentative product from sugars—primarily to demonstrate a means to achieve a modeled minimum fuel selling price under \$5/GGE by 2022. This design case serves to describe a *single, feasible* conversion pathway to transparently document the assumptions and details that went into its design. It is not meant to provide an exhaustive survey of process alternatives or cost-sensitivity analyses.

The process described in the design case uses co-current dilute-acid pretreatment of algal biomass delivered after upstream dewatering (outside the scope of this analysis) to 20 wt% solids, followed by whole-slurry fermentation of the resulting monomeric sugars to ethanol, followed by distillation and solvent extraction of the stillage to recover lipids (primarily neutral lipids with inclusion of polar lipid impurities). The process design also includes lipid product purification, product upgrading (hydrotreating) to straight-chain paraffin blend stocks, anaerobic digestion and combined heat and power (CHP) generation, product storage, and required utilities. See Figure 2-15 for the process flow diagram.

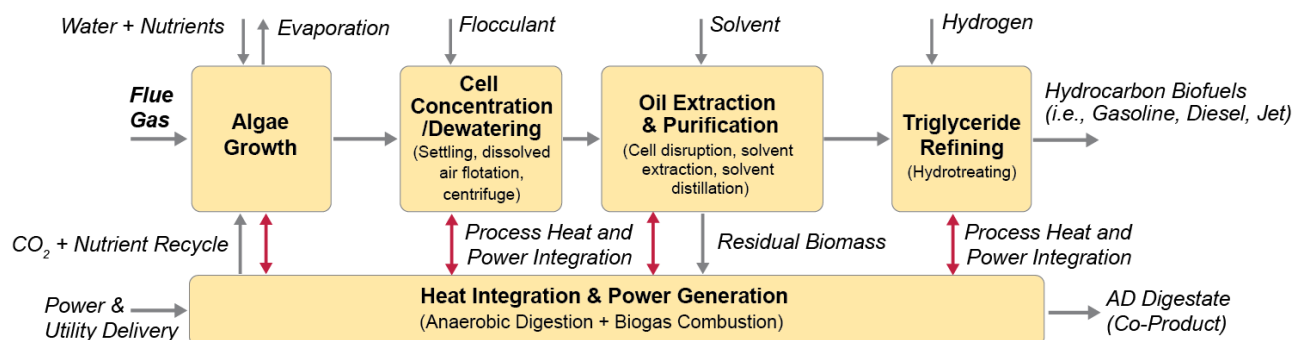

Figure 2-15: ALU process flow diagram

Figure 2-16 and Table 2-5 show projected minimum fuel selling prices for algae-based biofuel based on the yields and accompanying technical projections described in Appendix B, Table B-5. This is based on literature and project data from the 2012 Harmonized Baseline and 2014 ALU Design Case Report. The projections show that the greatest opportunity to reduce costs is

³¹ Ryan Davis, Daniel Fishman, Edward Frank, et al., “Renewable Diesel from Algal Lipids: An Integrated Baseline for Cost, Emissions, and Resource Potential from a Harmonized Model,” Argonne National Laboratory, ANL/ESDA/12-4 (2012), <http://greet.es.anl.gov/publication-algae-harmonization-2012>.

³² R. Davis, C. Kinchin, J. Markham, E.C.D. Tan, et al., “Process Design and Economics for the Conversion of Algal Biomass to Biofuels,” National Renewable Laboratory (2014). <http://www.nrel.gov/docs/fy14osti/62368.pdf>.

in the production systems through improved biomass yield and reduced cultivation capital costs. Significant cost improvements are also projected in feedstock harvest and preprocessing. To achieve the 2022 projection, biomass yield is targeted for a five-fold improvement through increased productivity and extractable lipid content, halving of capital costs for pond construction (including removing pond liners from the design), and significant capital and operability improvements in harvest and preprocessing.

Table 2-5: Summary of Cost Contributions for ALU Design Case

Unit Operation	2010 SOT ³³	2014 Projection ³³	2018 Projection ³³	2022 Projection ³⁴
Feedstock	\$16.50	\$10.60	\$5.19	\$3.05
Conversion	\$1.72	\$1.56	\$1.11	\$1.11
Hydrotreating	\$1.84	\$1.84	\$1.84	\$0.29
Aneorbic Digestion	\$0.68	\$0.65	\$0.47	(\$0.18)
Balance of Plant	\$0.00	\$0.00	\$0.00	\$0.08
Total	\$20.74	\$14.66	\$8.61	\$4.35

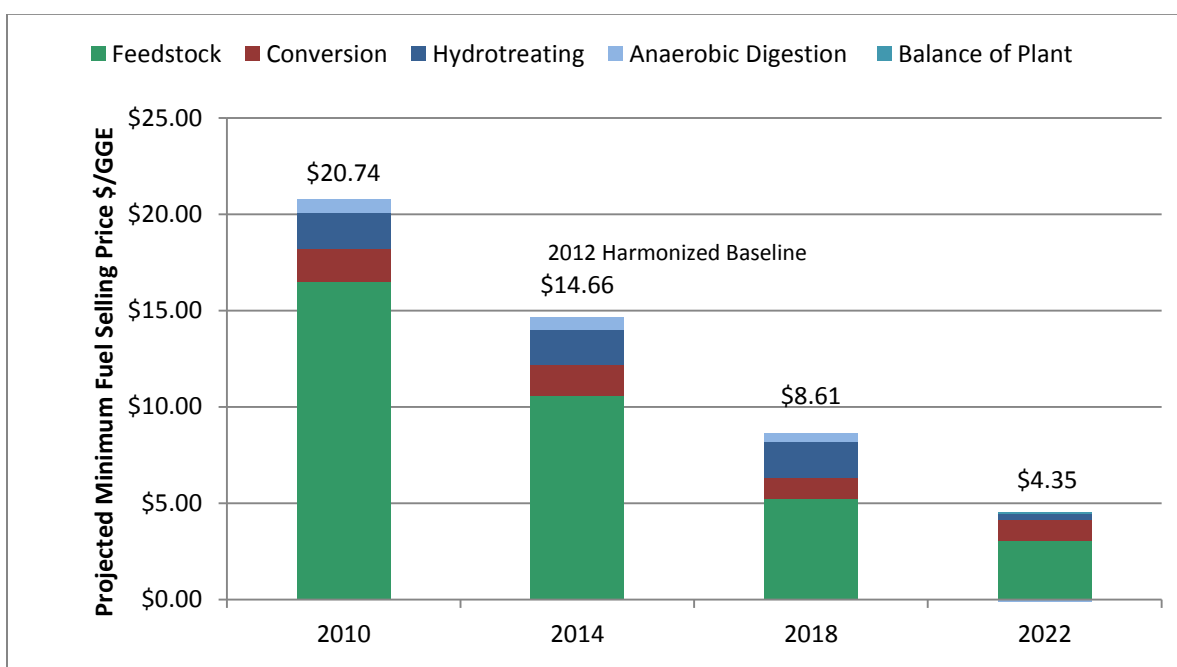

*Note: Information from the 2012 Harmonized Baseline 2010 State of Technology; 2014–2022 Projection.

Figure 2-16: Cost contribution by process area (per GGE total fuel) for ALU Pathway

³³ R. Davis, D. Fishman, E. Frank, et al., “Renewable Diesel from Algal Lipids: An Integrated Baseline for Cost, Emissions, and Resource Potential from a Harmonized Model,” Argonne National Laboratory, ANL/ESDA/12-4 (2012), <http://greet.es.anl.gov/publication-algae-harmonization-2012>.

³⁴ R. Davis, C. Kinchin, J. Markham, E.C.D. Tan, et al., “Process Design and Economics for the Conversion of Algal Biomass to Biofuels,” National Renewable Laboratory (2014).

Algal Hydrothermal Liquefaction Pathway (AHTL)

The focus of the Algal Hydrothermal Liquefaction Design Case³⁵ and resulting State of Technology Report³⁶ is to document a pathway model for conversion of whole algae, rather than the extracted lipids, to fuel and other products. Dewatered algae (20 wt% on an ash-free basis) is pumped to the HTL reactor. Condensed phase liquefaction then takes place through the effects of time, heat and pressure. The resulting AHTL products (oil, solid, aqueous, gas) are separated, and the AHTL oil is hydrotreated to form diesel and some naphtha-range fuels. The AHTL aqueous phase is catalytically treated to recover the carbon content and allow water recycle back to the ponds. Process off-gas may be used to generate hydrogen, heat and/or power. A hydrogen source is included as hydrotreating is assumed to be co-located with the algae ponds and AHTL conversion. Nutrient recovery is accomplished by recycling treated water, carbon dioxide containing flue gas, and treated solids back to the algae ponds. See the process flow diagram, Figure 2-17.

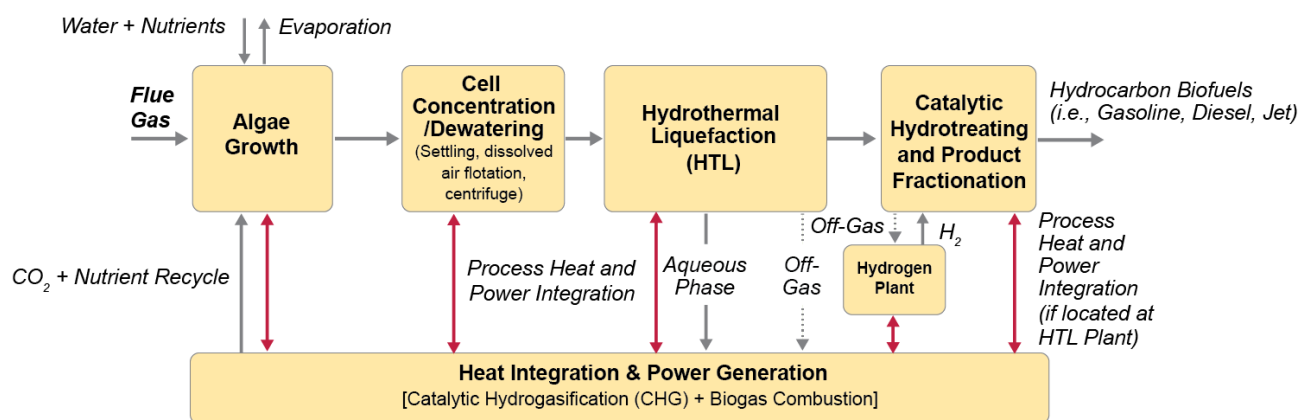

Figure 2-17: AHTL process diagram

The basis for this case is an algae farm operating at 30 g/m²/day and producing a yearly average of 1,340 tons per day of algae (dry and ash-free basis) delivered to the AHTL plant as 20 wt% solids slurry, with the 10,000 acres of ponds as also assumed in the 2012 harmonization work. All algal conversion steps to finished diesel are assumed to take place adjacent to the algae farm.

As in the ALU case, the cost to produce dewatered algae is the single most significant factor affecting the final fuel cost, as seen in Table 2-6 and Figure 2-18. Algal strain development is needed to optimize desirable characteristics such as a rapid growth rate. The key conversion improvements needed are in the area of improved AHTL oil separation from the AHTL aqueous phase.

³⁵ Jones et al. "Process Design and Economics for the Conversion of Algal Biomass to Hydrocarbons: Whole Algae Hydrothermal Liquefaction and Upgrading" Pacific Northwest National Laboratory Report 23227 (2014).

³⁶ S.B. Jones, Y. Zhu, L.J. Snowden-Swan, D.B. Anderson, R.T. Hallen, A.J. Schmidt, K.A. Albrecht, D.C. Elliott, "Whole Algae Hydrothermal Liquefaction: 2014 State of Technology Pacific Northwest Laboratory, June 2014.

This analysis demonstrates a strategy for achieving an overall fuel selling price near \$4.50/GGE, on-par with published targets for algal hydrothermal liquefaction processing. However, additional improvements will be required to further improve economics toward standard BETO targets closer to \$3/GGE.

Table 2-6: Summary of Cost Contributions for AHTL Design Case and SOT

Unit Operation, \$/GGE (2011\$)	2014 SOT	2022 Projected
Feedstock	\$13.21	\$3.31
AHTL	\$1.78	\$0.62
Hydrotreating	\$0.34	\$0.35
Catalytic Hydrothermal Gasification	\$0.74	\$0.63
Balance of Plant	(\$0.50)	(\$0.42)
Total	\$15.57	\$4.49

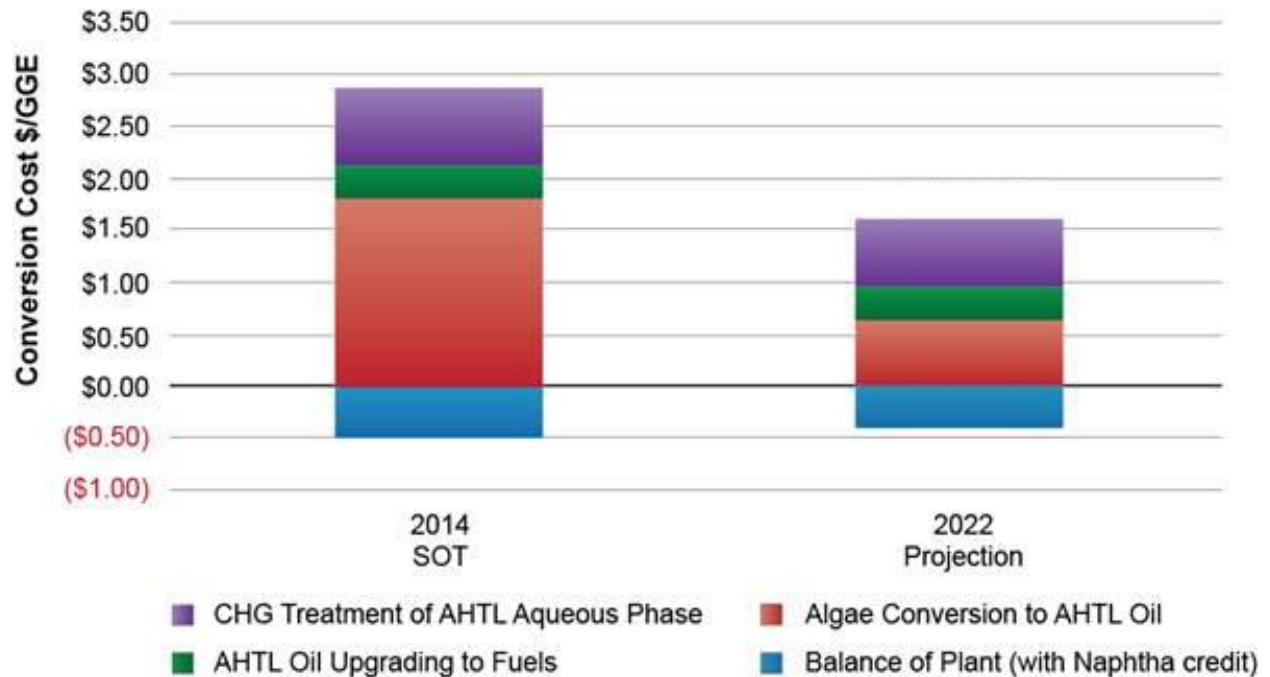

Figure 2-18: Cost contribution by conversion process area (per GGE total fuel) for AHTL Pathway

A comparison of the key parameters and cost contributions in these two cases is highlighted in Table 2-7, below.

Table 2-7: Comparison of Key Cost Contribution Details From Each Process Area (per GGE total fuel) for ALU and AHTL Design Cases

Key Cost Parameters	ALU Design	HTL Design
\$/GGE Minimum Fuel Selling Price (2011\$)	\$4.35	\$4.49
Yield, GGE/ton (ash free dry weight [afdwt])	138	130
Feedstock Cost (\$/ton afdwt)	\$430	-
Feed Rate (ton/day afdwt, seasonal average)	1339 +excess summer storage	-
Total Capital Investment/Annual (\$/GGE)	\$7.5	\$8.2
Naphtha (Total) Coproduct Credit (\$/GGE)	\$0.08 (\$0.35)	\$0.63 (\$0.63)
Power Balance: Net Electricity to (from) Grid (KWh/GGE)	0.9	(0.1)

2.1.2.6 Algal Feedstocks Research and Development Milestones and Decision Points

The key upcoming milestones and decision points for Algal Feedstocks R&D over the next five years (2013–2018) in support of the R&D approach to achieve the technology area’s 2022 performance goal are described above in Section 2.1.2.2 and illustrated below with accompanying decision points in Figure 2-19.

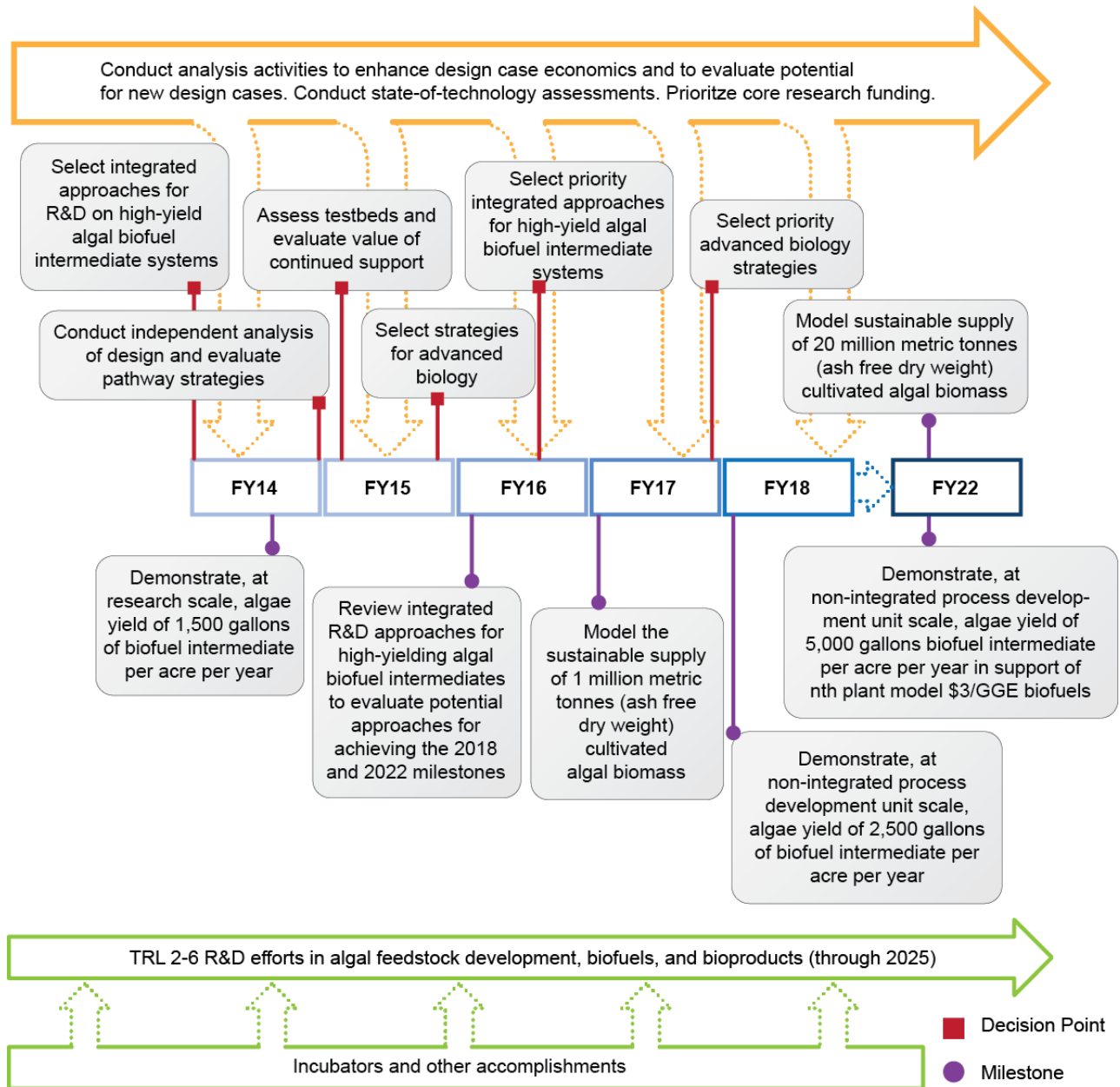

Figure 2-19: Algal Feedstocks R&D key milestones and decision points

2.2 Conversion Research and Development

The strategic goal of Conversion R&D is to *develop commercially viable technologies for converting biomass feedstocks into energy-dense, fungible, liquid transportation fuels, as well as bioproducts or chemical intermediates and biopower*. Biomass resource diversity results in a need to develop multiple conversion technologies that can efficiently deal with the broad range of physical and chemical characteristics of various feedstocks. Investing in multiple conversion technologies also reduces the risk that any specific technology could fail to reach commercial viability. The Office divides its Conversion R&D efforts into two areas: (1) Biochemical Conversion R&D, which focuses on pathways using sugars, other carbohydrates, and lignin intermediates; and (2) Thermochemical Conversion R&D, which focuses on pathways using bio-oil and gaseous intermediates. These focus areas are shown in Figure 2-20. Within each area, there are many possible variations, but the main differences are in the intermediate building blocks produced and the primary catalytic system employed.

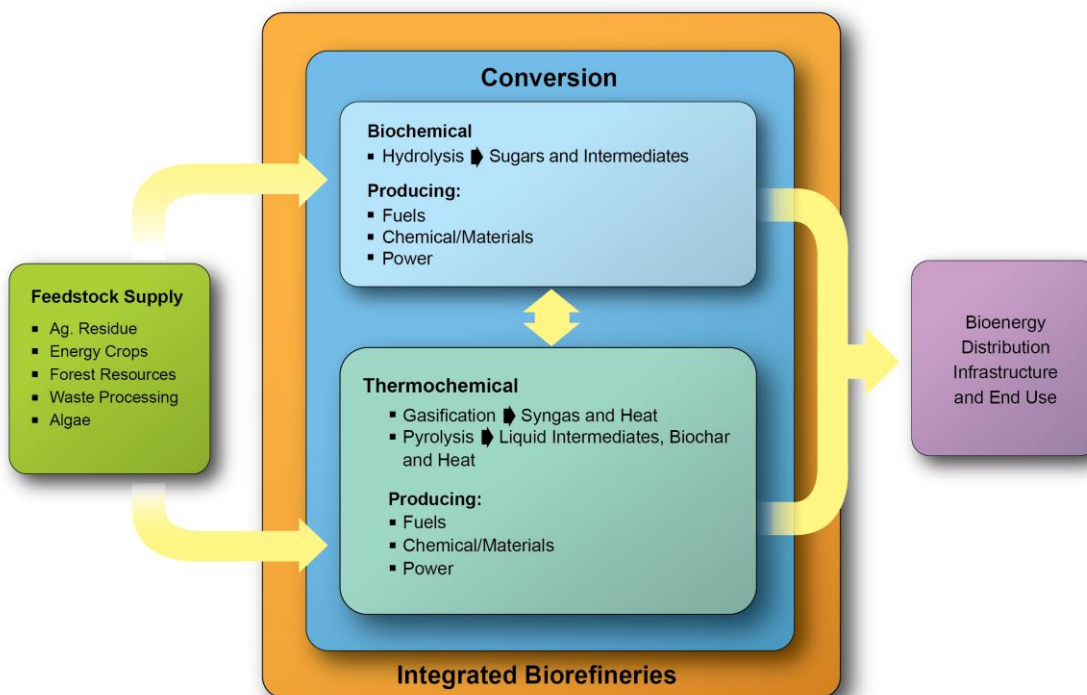

Figure 2-20: Conversion routes for biomass to bioenergy

While the Office addresses Conversion R&D needs through two separate technology routes—biochemical and thermochemical—it is envisioned that the combined use of technologies from both areas offers the greatest opportunity for optimizing biomass conversion into a variety of different fuels, chemicals, and energy products. The early years of the industry may not see such complex biorefineries, but complexity may be added as technologies evolve over time.

The Office also actively pursues R&D in technology areas that do not fit neatly into the two routes. This includes work on emerging technology, such as efforts in waste to energy, synthetic biology, and hybrid technology pathways.

2.2.1 Biochemical Conversion Research and Development

Biochemical Conversion R&D is focused on reducing the cost of converting lignocellulosic biomass to products such as liquid transportation fuels or chemicals via mixed, dilute sugars and other processable intermediate compounds. The critical steps in the conversion of biomass to fuels and chemicals include feedstock production, processing, storage, transport, and feeding; cost-effective pretreatment; high-yield conversion of intermediates to products; and product separation and purification. The key to effective and efficient conversion of biomass to finished products is obtaining high yields of desired intermediates along the supply chain.

Pretreatment typically involves mechanical, thermal, and/or chemical processes that disrupt the structure of biomass to produce the desired intermediates, which can then be further converted into the targeted products. In a typical biochemical conversion process (e.g., production of corn or cellulosic ethanol), biocatalysts—such as enzymes and microorganisms—in addition to physical forces and chemical catalysts, are used to convert the carbohydrate portion of the plant cell walls (i.e., hemicellulose and cellulose) into an intermediate sugar stream. The resulting sugars are intermediate building blocks, which are then biologically or chemically converted to various liquid fuels and chemicals. Other intermediates can include the oligomeric sugars derived from cellulose and hemicellulose, lignin, oleaginous materials, and by-products of the deconstruction steps, such as hydroxymethylfurfural and furfural.

Biological conversion processes typically utilize organisms such as yeast, filamentous fungi, bacteria, or algae with optimized metabolic pathways to convert these intermediates to targeted fuels and/or chemicals. Alternatively, chemical conversion employs catalysts to drive the reactions from intermediates to specific product suites. The remaining lignin portion of the feedstock has multiple uses, such as generation of heat and power (due to its relatively high energy content) or production of additional fuels and chemicals via thermochemical or catalytic (chemical or biological) processes.

Building on recent successes in the biochemical conversion of biomass to cellulosic ethanol, the Office is investigating a broad range of biological and chemical conversion routes to advanced biofuels, such as renewable gasoline, diesel, and jet fuel. Enabling the industry to reach its volumetric goals will require development of technologies that can achieve the following: (a) more feedstock-flexible and robust conversion processes, enabling use of a greater variety of feedstocks; (b) higher conversion yields, including increased product selectivity; (c) increased utilization of all feedstock components to enhance process economics; and (d) improved unit operations, including advanced bioreactor systems, better process control and monitoring, and increased process efficiencies. New biochemical conversion routes may also be able to leverage existing capital investment in biorefinery infrastructure, such as corn wet and/or dry mills and the new cellulosic biorefineries coming online in the near future.

Production of chemicals from intermediates does not only need to be considered as enhancing biorefinery economics; biological and chemical conversion methods can also be well-suited for specialty chemicals (rather than fuels) production in single-purpose facilities. One benefit of some of these conversion processes is that they produce specific, single-molecule chemicals with relatively high yields, with a few in excess of 1 gram of product per gram of glucose. These chemical building blocks can directly displace conventionally derived petroleum materials,

addressing the Office’s goal to replace the entire suite of products produced from an imported barrel of oil. Examples of value-added chemicals from biomass that have attractive market potential and are technically feasible include—but are not limited to—succinate; 2,5-furan dicarboxylic acid; and glutamate.^{37, 38}

Biochemical Conversion Process Steps

The conceptual block flow diagram in Figure 2-21 outlines the main technologies or unit operations of the biological and chemical feedstock-to-fuel process. There are multiple routes to fuels and chemicals, as shown in the various feedstock pathways in Appendix A. New routes to other advanced biofuels can be analogous to the Office’s published TEA for cellulosic ethanol,³⁹ with the addition of appropriate conversion organisms and modifications to the product upgrading and recovery processes. In addition, industry has recently developed alternative approaches, including non-fermentative routes that chemically or catalytically convert intermediates into fuel and chemical products.^{40, 41, 42, 43}

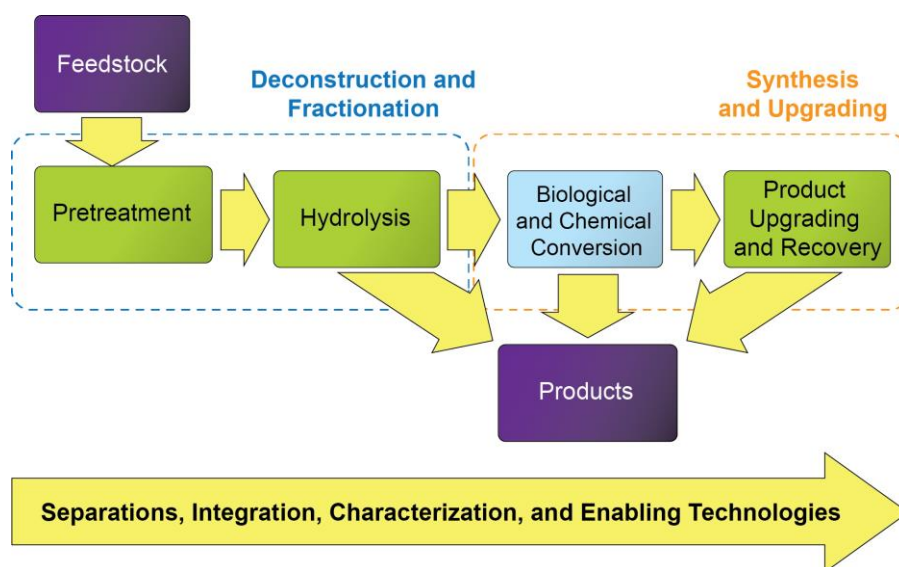

Figure 2-21: Generalized biochemical conversion route for feedstock to biofuels

³⁷ Werpy T.A., Holladay J.E., et al. “Top Value-Added Chemicals from Biomass: I. Results of Screening for Potential Candidates from Sugars and Synthesis Gas.” PNNL-14808. (2004). Richland, WA: Pacific Northwest National Laboratory.

³⁸ Holladay J.E., White J.F., et al. “Top Value-Added Chemicals from Biomass: II. Results of Screening for Potential Candidates from Biorefinery Lignin.” (2007). Richland, WA: Pacific Northwest National Laboratory.

³⁹ D. Humbird, R. Davis, et al. “Process Design and Economics for Biochemical Conversion of Lignocellulosic Biomass to Ethanol: Dilute Acid Pretreatment and Enzymatic Hydrolysis of Corn Stover.” NREL TP-510-47763. (2011). Golden, CO: National Renewable Energy Laboratory. <http://www.nrel.gov/biomass/pdfs/47764.pdf>.

⁴⁰ WIPO/PCT WO2012/166267 A2 Patent: Method to Convert Fermentation Mixture into Fuels. (2012).

⁴¹ B.C. Harvey and H.A. Mylemans. (2013). “1-Hexene: A renewable C6 platform for full-performance jet and diesel fuels.” *Green Chemistry* 2(1). DOI: 10.1039/c3gc41554f.

⁴² Bozell, J.J. and Petersen, G.R. (2010). “Technology development for the production of biobased products from biorefinery carbohydrates – the US Department of Energy “Top 10” revisited.” *Green Chemistry* 4(1). DOI: 10.1039/B922014C.

⁴³ <http://www.virent.com/news/virent-receives-doe-award-for-jet-fuel-development-2/>.

Figure 2-21 depicts a high-level view of the primary unit operations within the scope of biochemical conversion R&D to create desired biomass-derived products. These products can include finished fuels, fuel precursors, chemicals, or high-quality intermediates, such as sugars. Specific process operating conditions, inputs, and outputs vary within and between each step. These process variations impact key performance outcomes (titer, rate, and yield), which in turn determine economic viability during scale-up of the process. LCAs are also performed and environmental impacts assessed for conversion pathways.

Pretreatment: In pretreatment, feedstocks undergo processes to mechanically and/or chemically fractionate the lignocellulosic complex into soluble and insoluble components. This operation also opens up the physical structure of the plant cell walls to facilitate subsequent enzyme or chemical deconstruction to sugars and other intermediates. Soluble components include mixtures of five- and six-carbon sugars (xylose, arabinose, mannose, galactose, and glucose) and soluble oligomers of sugars. Insoluble components include other sugar oligomers, cellulosic polymers, and lignin (and anything else that may be linked to those insoluble constituents). Because the specific mix of sugars and oligomers released depends on the feedstock and the pretreatment technology employed, pretreatment technologies are selected based upon initial feedstock characteristics (proportions and types of carbohydrates and lignin) and the downstream process requirements. Pretreatment processes also affect lignin properties, including the molecular weight of the recovered lignin.

Conditioning: In some process configurations, the pretreated material goes through a hydrolysate conditioning and/or neutralization process to adjust the pH of the slurry. Conditioning, such as deacetylation to remove acetate groups, can remove undesirable by-products from pretreatment that are toxic to the downstream fermenting organism.⁴⁴ In some cases, conditioning and hydrolysis can be combined into a single process step.

Hydrolysis: In hydrolysis, the pretreated material is further decomposed, releasing glucose—a readily fermentable sugar. This can be done with enzymes, such as cellulases, or by using strong acids. Addition of other enzymes in this step, such as xylanases, may allow for less severe pretreatment conditions, potentially resulting in a reduced overall pretreatment and hydrolysis cost. Depending on the process design, enzymatic hydrolysis requires several hours to several days to complete, after which the mixture of sugars and any unreacted cellulose is transferred to the fermenter. Current processes typically use purchased enzymes or enzymes manufactured on site, based on the economics of the specific process. Some processes combine the hydrolysis and conversion steps (i.e., simultaneous saccharification and fermentation). On the forefront of technology development are processes that consolidate hydrolysis, saccharification, and conversion in the same reactor. Consolidated bioprocessing has started to show some promise.⁴⁵ In other technologies, such as those using strong acids for hydrolysis, acid recovery is important for viable economics and to reduce downstream wastewater treatment.

⁴⁴ X. Chen, et al. (2012). “The impacts of deacetylation prior to dilute pretreatment on the bioethanol process.” *Biotechnology for Biofuels* 5(8).

⁴⁵ http://www1.eere.energy.gov/bioenergy/pdfs/ibr_demonstration_mascoma.pdf.

Conversion: Intermediates are transformed into fuels and chemicals through either biological or chemical conversion processes.

Biological Conversion: Currently, the most common approach uses an inoculum of an organism added to feedstock hydrolysates. In this approach, sugars are converted at the same time the remaining cellulose is being hydrolyzed to glucose. After a few days of continued saccharification and conversion, nearly all of the sugars are converted to biofuels, precursors to hydrocarbons, or other chemicals of interest. The resulting aqueous mixture or two-phase broth is sent to product recovery.

Chemical Conversion: Chemical or chemical catalytic conversion can be used in place of, or in addition to, biological organisms to convert the intermediates to a desired end product. A variety of catalysts and reaction conditions can be employed to target different fuels and chemicals. Research is aimed at identifying optimal process conditions with respect to process efficiency, feedstock utilization, cost, sustainability, and finished product characteristics.

Product Upgrading and Recovery: Product recovery and upgrading varies based on the type of conversion used and the type of product generated, but generally involves any of a number of biological and chemical transformations, distillation, or other separation and recovery methods. This may include some clean-up processes to separate the product from the water and residual solids. Residual solids are composed primarily of lignin and ash, which can be burned for combined heat and power generation (a low-value product), chemically converted to intermediate chemicals, or converted to synthesis gas or bio-oil intermediates for fuels and chemicals.

Biochemical Conversion Interfaces

Feedstock Logistics Interface: A feedstock supply chain will need to be capable of providing preprocessed feedstock materials that meet the chemical and physical input requirements (e.g., composition, particle size, handling characteristics, rheology, density chemical characteristics, etc.) established by a baseline biochemical conversion process configuration. These input requirements are expected to vary, depending on the process configuration, feedstock, and geography. Close coordination with the FSL R&D Technology Area (see Section 2.1) is necessary to ensure that the feedstock and the conversion process are optimized in relation to each other, such that feedstock materials of sufficient quantity and quality are readily available for the lowest overall cost and highest possible conversion efficiency.

Demonstration Interface: Demonstration of biological and chemical processes in facilities of increasing scale can provide information relevant to process integration and commercial plant design. Additionally, challenges encountered during demonstration at all scales can be addressed through R&D performed at bench scale.^{46, 47, 48} The impacts of conversion technologies on

⁴⁶ http://www1.eere.energy.gov/bioenergy/pdfs/ibr_arra_logos.pdf.

⁴⁷ http://www1.eere.energy.gov/bioenergy/pdfs/ibr_arra_myriant.pdf.

⁴⁸ http://www1.eere.energy.gov/bioenergy/pdfs/ibr_arra_ineos.pdf.

wastewater treatment and heat and power integration are especially significant. Research, development, and demonstration (RD&D) accomplishments are incorporated into the design of the pioneer-scale integrated biorefineries, as demonstrated by the success of projects within the Office's Demonstration and Deployment portfolio, including INEOS, Abengoa, and POET. Additionally, biofuels and chemicals leaving a biorefinery must meet all applicable federal, state, and local codes and standards, necessitating feedback along the RD&D pipeline.

Analysis Interface: Conversion technologies are evaluated by TEA and LCA, necessitating interfaces between research, analysis activities, and the cross-cutting Strategic Analysis and Sustainability Technology Areas (Sections 2.4 and 2.5). TEAs and LCAs inform strategic planning on optimal R&D areas and document progress toward achieving the programmatic goals. Data on greenhouse gas emissions, as well as energy and water use, also inform the Office's sustainability analysis activities.

2.2.1.1 Biochemical Conversion Research and Development Support of Office Strategic Goals

The strategic goal of the Biochemical Conversion Technology Area is to *develop commercially viable technologies for converting feedstocks via biological and chemical routes into energy-dense, fungible, liquid transportation fuels and chemicals.*

The R&D portfolio directly addresses and supports development of technologies necessary for producing fuels and chemicals from high-impact feedstocks, including herbaceous, woody, energy crop, and algal feedstocks, as well as from some sorted portions of MSW.

2.2.1.2 Biochemical Conversion Research and Development Support of Office Performance Goals

The overall performance goal of Biochemical Conversion R&D is to reduce the estimated mature technology processing cost⁴⁹ for converting intermediates derived from cellulosic feedstocks to hydrocarbon fuels via biological or chemical pathways:

- By 2017, achieve an nth plant modeled conversion cost of \$3.30/GGE utilizing blended feedstock via a biochemical or chemical conversion pathway. This contributes to a minimum fuel selling price (MFSP) of \$5.10/GGE in 2011 dollars, an interim target on the path to \$3.00/GGE fuels.⁵⁰ The interim target only considers the production cost of the fuel; concurrent production of chemicals may enable an overall MFSP of \$3.00/GGE by 2017.

⁴⁹ Estimated mature technology processing cost means that capital and operating costs are assumed to be for an "nth plant" where several plants have been built and are operating successfully, so additional costs for risk financing, longer startups, under performance, and other costs associated with pioneer plants are not included.

⁵⁰ R. Davis, L. Tao, et al. "Process Design and Economics for the Conversion of Lignocellulosic Biomass to Hydrocarbons: Dilute-Acid and Enzymatic Deconstruction of Biomass to Sugars and Biological Conversion of Sugars to Hydrocarbons." NREL/ TP-5100-60223. (2013). Golden, CO: National Renewable Energy Laboratory. <http://www.nrel.gov/docs/fy14osti/60223.pdf>.

- By 2022, achieve the conversion cost necessary to contribute to the overall Office performance cost goal of \$3/GGE (\$2011).

The current near-term performance milestones for Biochemical Conversion R&D are as follows:

- By 2014, establish out-year cost goals and technical targets for catalytically derived hydrocarbon fuels based on TEA for one technology pathway.
- By 2017, validate the production of a hydrocarbon fuel or fuel blendstock from cellulosic or algal feedstock via at least one biological or chemical route at bench scale to measure progress against an interim modeled conversion cost goal (nth plant, \$2011) of \$3.30/GGE.

Preliminary analyses suggest that achievement of Office cost goals will require economic contributions from coproduct development in addition to technological advancements from R&D for biofuels.

2.2.1.3 Biochemical Conversion Research and Development Challenges and Barriers

The challenges and barriers listed in this section highlight areas in which improvements to processes are crucial to advancing the Office's mission. The aim for all processes is an increase in both carbon and energy efficiency relative to the theoretical maximum. The challenges are categorized into two areas: (1) those that relate to the inherent physical properties of biomass and feedstocks and its use in biological and chemical processes, and (2) those that relate to the processing of feedstock within conversion systems. The challenges addressed in the first area include compositional variability, various physical properties, and recalcitrance to chemical and biological processing. In the second area, challenges in processing technologies such as hydrolysis, saccharification, microbial fermentation, and downstream separations are identified.

Technical Research and Development Challenges and Barriers Inherent to Feedstocks Utilization

Bt-A. Biomass and Feedstock Variability: Feedstock variability can affect overall conversion process performance, including conversion rate and product yield, which directly impacts process economics, environmental factors, and—ultimately—the viability of the process. The characteristics of biomass can vary widely in terms of physical parameters (e.g., size, shape, bulk density, surface area, pore volume, etc.) and chemical composition (e.g., moisture, ash, carbohydrate, lignin, etc.), even within a single species. This variability can make it difficult (or costly) to reliably supply biorefineries with formatted feedstocks of consistent, acceptable quality year-round and maintain adequate process control.

Bt-B. Biomass and Feedstock Recalcitrance: The fundamental role that cell wall architecture and composition play in determining its resistance to decomposition is not well-understood. Lignocellulosic feedstocks are naturally resistant to chemical and/or biological degradation. This knowledge gap highlights the efforts needed to improve the cost effectiveness and efficiency of pretreatment and other fractionation and conversion processes.

Technical Research and Development Challenges and Barriers to Processing Feedstocks

Bt-C. Reactor Feed Introduction: Several variables impact the behavior of materials while being fed into a conversion process, including feedstock type (and feedstock blend), format, particle size, shape, and size distribution, as well as conversion reactor design and process conditions. Several new feedstocks will be examined for use in the suite of conversion technologies being developed. These feedstocks may vary significantly from those historically used in biochemical conversion systems. This variability may make reactor infedding a significant challenge and can impact conversion performance. The performance of feedstock blends and formats needs to be evaluated to reduce technical risks to commercial scale-up.

Bt-D. Pretreatment Processing and Selectivity: Chemical, mechanical, and/or thermal pretreatments can be employed to alter the structure of biomass to increase the efficiency of subsequent cell wall carbohydrate polymer hydrolysis or to carbohydrate intermediates. The resulting lignin and degradation products can inhibit the downstream processing steps following pretreatment; therefore, optimal process parameters need to be developed to maximize production of the desired intermediates while minimizing production of inhibitors or removing them altogether.

Bt-E. Pretreatment Reactor Design and Optimization: Pretreatment reactors typically require expensive construction materials to resist acid or alkali attack at elevated temperatures and pressures. In addition, the impact of reactor configuration and reactor design on chemical cellulose prehydrolysis is not well-understood. Developing lower-cost pretreatment depends on the ability to process the feedstock in reactors fabricated from cost-effective materials that are designed for maximum solids content and compatibility with process conditions.

Bt-F. Hydrolytic Enzyme Production: Hydrolytic enzymes remain a significant portion of the projected production cost of converting sugars from cellulosic feedstocks. Significant progress has been made through targeted public and private R&D efforts; however, the cost and efficiency of enzyme production continues to impact the economics of an integrated process. Unique proteins that target deconstruction of residual substrates need to be identified in order to augment process yields, and the production strains for these enzymes need to be optimized for commercial production. This includes R&D activities to increase efficiency and reduce the cost of other deconstruction enzymes, such as lignin-modifying enzymes.

Bt-G. Enzyme Efficiency: Reducing the cost of enzymatic hydrolysis depends on identifying more efficient enzyme preparations and hydrolysis parameters that enable cost-effective release of sugars, intermediates, or lignin. The target is to reduce the ratio of enzyme protein mass required to solubilize the substrate (i.e., increased specific activity). In addition, commercially available enzymes are not sufficiently thermostable and also suffer from substantial end-product inhibition. Developing enzymes that enable low-cost enzymatic hydrolysis technology requires a better understanding of the fundamental mechanisms underlying the biochemistry of enzymatic hydrolysis, including the impact of feedstock architecture on the ability of enzymes to decrystallize cellulose during hydrolysis. Additional efforts aimed at understanding both the interaction of enzymes with substrates and the optimal molecular-level hydrolysis environment

are needed to achieve the targeted specific activity improvements that can further reduce enzyme cost.

Bt-H. Cleanup/Separation: Solutions produced during pretreatment and hydrolysis contain a mixture of sugars and non-sugar components. Potential impurities include acetic acid released during hemicellulose hydrolysis, lignin-derived phenolics solubilized during pretreatment, inorganic acids or alkalis, other compounds introduced during pretreatment, various salts, and hexose and pentose sugar degradation or transglycosylation products. The presence of some impurities can inhibit the function of downstream biological and chemical catalysts. Low-cost purification technologies need to be developed that can remove impurities from hydrolysates and provide concentrated, clean feedstocks to manufacture biofuels and biobased chemicals.

Bt-I. Catalyst Efficiency: There is a need for efficient biological and inorganic catalysts that can transform the carbohydrate mixture and other hydrolysate components into advanced biofuels, chemicals, and fuel intermediates. Significantly lower capital and operating costs may be achieved through improvement in the productivity, efficiency, selectivity, regeneration time and lifetime, and robustness of catalysts (bacterial, fungal, algal, or inorganic) and their ability to utilize hydrolysate or synthesis gas. Developing lower-cost catalysts depends on the ability to efficiently convert and upgrade intermediates in reactors fabricated from cost-effective materials that are optimized to process conditions.

Bt-J. Biochemical Conversion Process Integration: Process integration remains a key technical barrier hindering development and deployment of biochemical and chemical conversion technologies. These conversion technologies currently present large scale-up risks given the lack of high-quality performance data on integrated processes carried out at the high solids conditions required for commercially viable industrial operations. The effect of feed and process variations throughout the process must be understood to ensure efficient operations and profitability. Process integration work is essential for characterizing the complex interactions that exist between many of the processing steps, including identifying unrecognized separation requirements, optimizing reactor design, minimizing waste streams, addressing bottlenecks and knowledge gaps, and generating integrated performance data. This integrated performance data is necessary to develop predictive mathematical models that can guide process optimization and scale-up. Wastewater and heat and power generation impacts upon integrated processes need to be identified and addressed through R&D. Simply, characterizing the various integration issues for biochemical processing will lower risks in successfully building and operating pilot- and demonstration-type facilities.

Bt-K. Product Acceptability and Performance: Biofuels leaving a biorefinery must meet all applicable federal, state, and local codes and standards. As the Office broadens its Biochemical Conversion R&D portfolio from ethanol to include infrastructure-compatible hydrocarbons, close coordination with the Demonstration and Deployment Technology Area and traditional petroleum refiners will be essential to ensure that desired product quality characteristics are met. Additionally, these same considerations would need to be made for any bio-intermediates entering conventional petroleum refineries. Lastly, chemicals produced via biological or chemical upgrading processes must meet various technical performance criteria and end-use

specifications, all of which should be considered during the R&D phase to help direct the research and measure project progress.

2.2.1.4 Biochemical Conversion Research and Development Approach for Overcoming Challenges and Barriers

The approach for overcoming conversion technical challenges and barriers is outlined in the WBS depicted in Figure 2-22.

The Office's current Biochemical Conversion activities generally fall into seven broad groupings:

- *Analysis and Sustainability:* To understand the impact of biochemical and chemical conversion technologies with respect to environmental and economic metrics
- *Feedstock Interface Activities:* To understand the impact of feedstock quality conversion performance characteristics
- *Deconstruction Processes:* To overcome biomass and feedstock recalcitrance
- *Upgrading Processes:* To convert deconstructed feedstocks to fuels, intermediates, and chemicals
- *Integration and Intensification:* To optimize for systems-level performance
- *Conversion Enabling Technologies:* To apply new knowledge and tools to innovate beyond current conversion technologies
- *Validation:* To demonstrate improvements in technologies, sustainability, and economics in an increasingly integrated process setting.

Technical challenges in each of these areas are identified from technology roadmapping, TEAs, stakeholder meetings, industry lessons learned from demonstration and deployment activities, and through active project management of historical and existing projects. Research addressing key technical challenges is performed by national laboratories, industry, universities, and multi-disciplinary consortia. The relevance, impact, and progress of the R&D portfolio toward industrial and commercial applications are ensured via project stage-gate and biennial portfolio reviews with a panel of external experts, partnering with industry as appropriate, and disseminating the results.

The R&D approach of each group of activities is described below, while Table 2-8 summarizes each activity element's work as it relates to specific challenges and technology pathways.

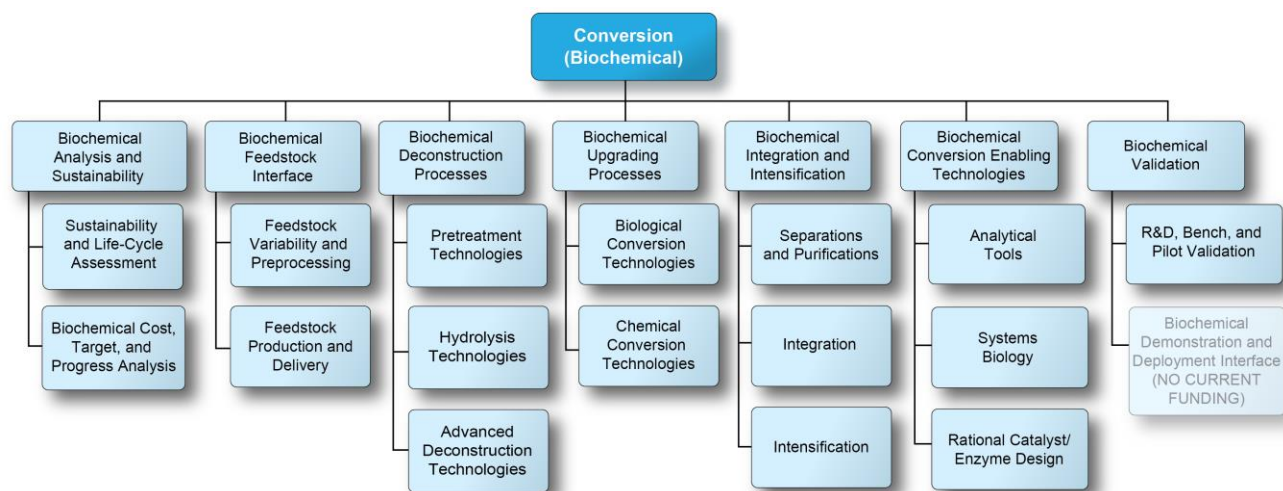

Figure 2-22: Biochemical conversion R&D work breakdown structure

Analysis and Sustainability

Analysis and sustainability activities play a critical role in understanding the feasibility, sustainability, and scalability of new conversion routes to hydrocarbon fuels and biobased chemicals. The process simulation, environmental sustainability assessments, and life-cycle models that are developed through these activities can be used in establishing baselines, developing performance targets, monitoring the progress of the research portfolio, as well as in understanding the tradeoffs among technology options within a systems context. The modeling outputs, including—but not limited to—process TEAs, SOTs, and LCAs will help to continually inform decisions concerning priority conversion pathways and opportunities to accelerate a unit operation, as well as identify additional R&D for efficient and environmentally benign conversion processes. Examples of environmental sustainability metrics include life-cycle greenhouse gas emissions, fossil energy consumption, consumptive water use, wastewater generation, air pollutants, biomass carbon-to-fuel efficiency, renewable energy production, value of additional products, and total fuel yield.

Feedstock Interface

Biochemical and feedstock interface activities include the R&D necessary to determine a desirable specification range for feedstocks intended for biochemical conversion processes. Additionally, this area includes the tasks necessary to produce the required volumes of feedstock at the optimal format and material specifications to support R&D and other scale-up activities. Linking feedstock harvest, collection, and transport processes with conversion processes allows for the evaluation of technology options and tradeoffs on both sides of the processing interface, ensuring a fully integrated supply chain from stump or field to fuel. Additionally, the Office is investigating the development of preprocessing options (e.g., densification, blending, and physical formats such as pellets, shredded material, and slurries) and simultaneously assessing the impact on conversion efficiency when such preprocessed feedstocks are introduced into a process.

Deconstruction Processes

Overcoming biomass and feedstock recalcitrance is a key challenge in deconstructing feedstock into sugars or other soluble carbon intermediates for subsequent fuel or biobased chemicals synthesis. The pretreatment subactivity focuses on developing cost-effective pretreatment options that consider reaction chemistry and reactor design associated with deconstructing or partially deconstructing feedstocks into intermediate compounds. The pretreated material is then exposed to chemicals or microbial enzymes during the hydrolysis step in which the carbohydrate polymers are hydrolyzed to largely monomeric glucose and xylose molecules. Advanced deconstruction processes or technologies that seek to combine or bypass the pretreatment and saccharification steps are also being developed and optimized. Deconstruction technologies that enhance the value of lignin are also sought.

Biochemical Upgrading

Soluble sugars and other carbon intermediates are upgraded to hydrocarbons, fuel precursors, and biobased chemicals using biological and/or non-biological conversion technologies. Upgrading technologies, whether biological or chemical, must produce fuels, fuel precursors, or chemicals that maximize the available carbon from the feedstock. Within the biological upgrading subactivity, the primary objective is identification of robust microorganisms capable of converting complex intermediates to desired target molecules in the presence of inhibitors at high rates, titers, and yields. Within the chemical upgrading subactivity, the primary objectives are development of specific and durable inorganic catalysts with appropriate selectivity, improved regenerability, catalyst supports, and optimization of process conditions to improve rates and yields.

Integration and Intensification

Investigating pretreatment and hydrolysis technologies together with downstream upgrading can help identify the interfacial issues and opportunities for integration. These could include separations, integration of individual unit operations into a process, and advanced process intensification efforts, such as consolidated processing and similar strategies. By starting to integrate the biofuels production steps in Process Demonstration Units and other user or pilot facilities, the overall process efficiency and costs can be improved in a systems context, which is a necessary precursor for scale-up activities. In addition, the effect of feed and process variations throughout the process must be understood to ensure robust, efficient biorefineries that produce fuels and chemicals on a consistently cost-effective basis. Lessons learned from these activities will be shared with the biochemical conversion-related integrated biorefineries to promote technology transfer and, vice-versa, to identify remaining R&D challenges.

Conversion Enabling Technologies

Efficient and highly productive biological and non-biological catalysts for biofuel production are necessary. Optimization of hydrolytic enzymes or a platform microorganism requires a fundamental understanding of the biological processes governing culture and host selection, gene expression, protein folding, modification, secretion, metabolic flux, and the metabolite transport. In addition, a fundamental understanding of the factors and causes underlying biomass

recalcitrance to biochemical degradation is needed to enable more specific feedstock processing at a lower cost. The development of tools such as molecular modeling and cell wall microscopy will enable a more complete understanding of biomass structure and the most appropriate methods to deconstruct cell walls into components.⁵¹ Other approaches, such as systems and synthetic biology, will be examined for their ability to make potential transformational changes in conversion technology efficiency and costs. For chemical and inorganic catalyst development, catalyst inactivation and support structures need to be understood on a mechanistic level to enable rational designs that enhance catalyst productivity and specificity. The further development and implementation of new technologies, like kinetic and multi-scale modeling, that can be validated with authentic feedstocks advance the state-of-the-art technology and will also be sought to enable conversion-enhancing parameters that positively impact yields, efficiencies, and costs.

Validation

The ultimate verification that ongoing R&D activities have progressed and achieved desired outcomes is demonstration of biochemical conversion technology routes that enable price-competitive production of finished fuels or bio-intermediates for refineries, as compared to petroleum-based counterparts. Integration and scale-up efforts at the bench and pilot scale generate data that is used to assess progress against technical performance and environmental metrics, as well as cost targets. This operational data is also used to inform analysis and sustainability efforts to model nth plant costs and technical projections for each biochemical conversion pathway. The Office leverages industry and demonstration partner feedback to understand emerging issues and R&D opportunities.

⁵¹ Shishir Chundawat, Gregg Beckham, et al. (2011). "Deconstruction of Lignocellulosic Biomass to Fuels and Chemicals." *The Annual Review of Chemical and Biomolecular Engineering* 2(1).
<http://www.annualreviews.org/doi/abs/10.1146/annurev-chembioeng-061010-114205>.

Table 2-8: Biochemical Conversion R&D Activity Summary

WBS Element	Description	Barrier(s) Addressed	Feedstock(s) Addressed
Analysis and Sustainability	Develop, refine, and utilize LCAs and TEAs for priority and alternative biochemical conversion routes. <ul style="list-style-type: none"> - Evaluate and identify performance improvements to technology pathways with respect to sustainability metrics. - Develop and update process analyses, design cases, and annual assessments of SOT (including technical, cost, and environmental sustainability metrics) for biochemical and hybrid processing routes to hydrocarbon fuels and biobased chemicals. 	Bt-J: Biological Conversion Process Integration St-C: Sustainability Data across the Supply Chain St-D: Sustainability Implementing Indicators and Methodology for Evaluating and Improving Sustainability St-E: Best Practices and Systems for Sustainable Bioenergy Production At-A: Comparable, Transparent, and Reproducible Analyses At-C: Data Availability across the Supply Chain	
Feedstock Interface	Develop feedstock specifications and processing systems that accommodate feedstock variability and are optimized for convertibility. <ul style="list-style-type: none"> - Understand feedstock variability, logistics, and preprocessing intermediates and develop options for mitigating impacts on downstream conversion technologies. - Define and produce on-spec materials for conversion testing. 	Ft-G: Biomass Materials Properties and Variability Ft-J: Overall Integration and Scale-Up Bt-A: Biomass and Feedstock Variability Bt-B: Biomass and Feedstock Recalcitrance Bt-C: Biomass Feed Introduction	
Deconstruction Processes	Develop technologies for converting biomass into sugars or other soluble carbon intermediates for subsequent biological or chemical conversion to hydrocarbon fuels, fuel intermediates, or chemicals. <ul style="list-style-type: none"> - Develop cost-effective pretreatment options. - Develop cost-effective hydrolysis options. - Develop advanced deconstruction options. 	Bt-A: Biomass and Feedstock Variability Bt-B: Biomass and Feedstock Recalcitrance Bt-C: Biomass Feed Introduction Bt-D: Pretreatment Processing and Selectivity Bt-E: Pretreatment Reactor Design and Optimization Bt-F: Hydrolytic Enzyme Production Bt-G: Enzyme Efficiency Im-E: Cost of Production	Agricultural Residues Energy Crops Forest Resources
Upgrading Processes	Develop technologies to optimize and maximize the utilization of the carbon from deconstructed biomass to synthesize desired product targets. <ul style="list-style-type: none"> - Develop cost-effective biological fuel synthesis technologies. - Develop cost-effective, non-biological fuel synthesis technologies. 	Bt-H: Cleanup/Separation Bt-I: Catalyst Efficiency Bt-K: Product Acceptability and Performance Im-E: Cost of Production	Waste Materials Algae
Integration and Intensification	Develop strategies that enable integration and/or process intensification. <ul style="list-style-type: none"> - Develop technologies for separation and purification of intermediates and chemicals. - Integrate and optimize deconstruction and product synthesis processes across interfaces. - Develop process intensification technologies. - Develop technologies to meet manufacturing specifications of innovative bio-derived materials, such as carbon fibers. 	Bt-H: Cleanup/Separation Bt-J: Biological Conversion Process Integration Im-E: Cost of Production It-A: End-to-End Process Integration	
Conversion Enabling Technologies	Enable the understanding of feedstock interface, deconstruction, and fuel synthesis processes to develop advanced technologies. <ul style="list-style-type: none"> - Develop and apply new analytical methods and tools. - Develop and apply systems biology tools. - Develop and apply rational designs of biological enzymes and inorganic catalysts. 	Bt-A: Biomass and Feedstock Variability Bt-B: Biomass and Feedstock Recalcitrance Bt-D: Pretreatment Processing and Selectivity Bt-F: Hydrolytic Enzyme Production Bt-G: Enzyme Efficiency Bt-H: Cleanup/Separation Bt-I: Catalyst Efficiency Bt-K: Product Acceptability and Performance Im-D: Lack of Industry Standards and Regulations	

WBS Element	Description	Barrier(s) Addressed	Feedstock(s) Addressed
Validation	Validate the sustainability and technical improvements of the integrated conversion technologies for the priority pathways. <ul style="list-style-type: none"> - Establish R&D baselines and protocols. - Operate the R&D pilot facilities to demonstrate feasibility and scalability. 	Bt-J: Biochemical Conversion Process Integration Bt-K: Product Acceptability and Performance	

2.2.1.5 Prioritizing Biochemical Conversion Research and Development Barriers

In order to achieve the Biochemical Conversion R&D goals, all of the challenges and barriers identified need to be addressed. However, the following issues are considered critical and will be emphasized within near- to mid-term Biochemical Conversion R&D efforts:

- Develop innovative biomass deconstruction approaches to lower the cost of intermediates
- Enable high-performance separations technologies to increase product yields and decrease cost
- Develop a broader range of biochemical conversion technologies to hydrocarbon fuels and chemicals.

The progress and future direction of the Office's R&D is monitored and evaluated to determine the annual R&D priorities necessary to overcome technical barriers identified in Section 2.2.1.3. These technology assessments help prioritize which biochemical conversion pathways could support the Conversion R&D 2022 \$3/GGE cost goal. From now through 2022, R&D activities will focus on developing and validating additional feedstock and conversion processes that can meet a \$3/GGE cost goal in order to maximize biofuels production in conjunction with value-adding chemicals.

To identify new approaches and technology routes, additional TEAs are being conducted to reflect the progress and potential impact of the Office's diverse R&D portfolio. Two TEAs (one existing and one in development) have been selected as the biochemical conversion design cases, representing a model process for each of the biological and catalytic pathways described. Additional TEAs can provide an understanding of other conversion pathways that produce hydrocarbon fuels, and when factored in with other criteria such as environmental performance, will help the program reprioritize and allow for the development of additional design cases for new, innovative conversion pathways. Periodic evaluations of the SOT also serve as "on ramps" and "off ramps" for conversion pathways or technologies that may or may not meet Office goals. Additionally, qualitative public input through stakeholder workshops (such as the Conversion Technologies for Advanced Biofuels Workshop held in December 2011) and the biennial Peer Reviews informs research priorities.

The design case model for biological production of diesel blendstocks details a model process that includes unit operations such as pretreatment, enzymatic hydrolysis, solid/liquid separations, and aerobic fermentation (biological conversion), followed by hydroprocessing. This design case and subsequent design report shows one potential path, based on current knowledge, to a \$3/GGE cost goal for biofuels with an interim cost goal of \$5/GGE in 2017. The cost projections associated with the technical improvement targets to meet this intermediate 2017 biochemical milestone are illustrated in Figure 2-23. Note that the achievement of the \$3/GGE cost goal for biofuels will likely require incorporating the co-production of a biobased chemical with higher value than fuel.

Certain routes to co-produced biobased chemicals are expected to be more complementary to select conversion processes than others on the basis of theoretical yields or production volumes, which can be a driving factor for biorefinery product slate selection. Another driving factor is environmental sustainability. Biobased competitors are expected to provide environmental

advantages to the conventional production methods for some chemicals currently produced by the petrochemical refining processes while providing similar performance and cost. As technology advances and processes mature, we expect to be able to better define a path to the \$3/GGE Office performance goal.

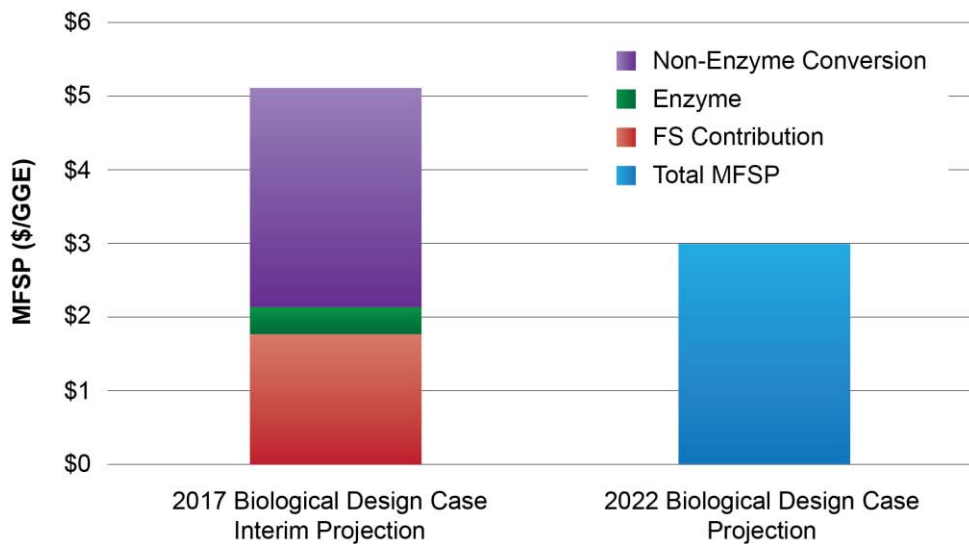

Figure 2-23: Biochemical conversion R&D barrier areas and example metrics

In addition to setting technical targets and cost projections, the Office is assessing the environmental performance of conversion pathways to enable continual evaluation and improvement of the designs throughout the technology R&D phase. The following environmental sustainability indicators are currently being assessed:

- Greenhouse gas emissions
- Fossil energy consumption
- Fuel yield
- Biomass carbon-to-fuel efficiency
- Consumptive water use
- Wastewater generation.

This set of environmental sustainability metrics will be expanded and updated as more experimental data become available. Work is currently in progress to quantify additional metrics, such as criteria air pollutants. The refined analysis will enable the Office to establish targets for environmental sustainability metrics to guide their improvement alongside the techno-economic performance. See Appendix C for more information on the Office’s approach to establishing environmental sustainability targets.

While the Energy Independence and Security Act of 2007 requires EPA to conduct its own greenhouse gas assessments to determine fuel qualification, it is essential that LCA be performed during the development of these pathways in order to predict and facilitate improvement of environmental performance. This will better enable conversion technologies to meet legislated

goals, such as greenhouse gas reductions required by the Renewable Fuel Standard, and achieve other social and environmental benefits.

2.2.1.6 Biochemical Conversion Research and Development Milestones and Decision Points

The high-level Biochemical Conversion R&D strategy program decision-making process, including milestones and decision points, is summarized in Figure 2-24.

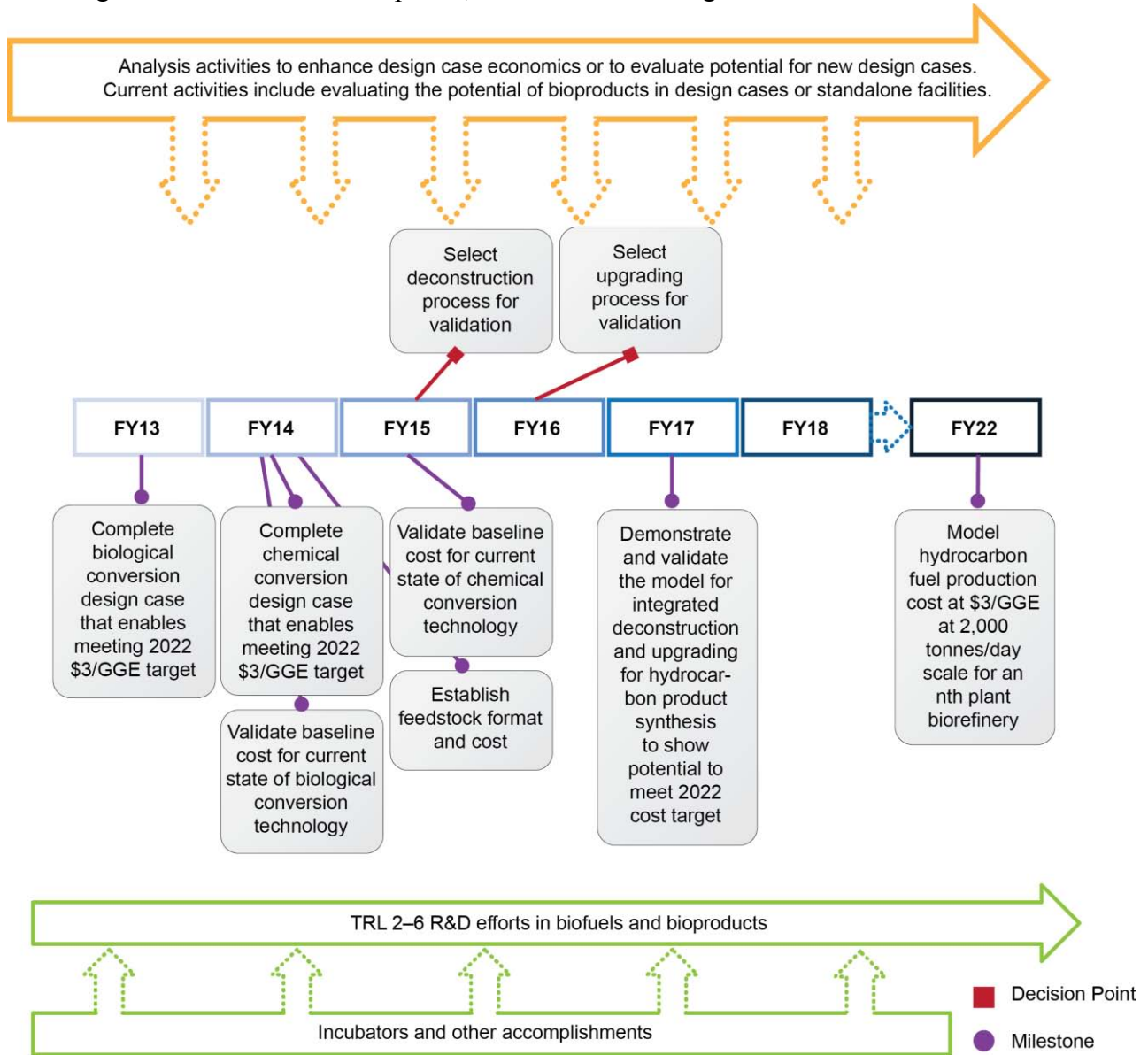

Figure 2-24: Biochemical conversion R&D key milestones and decision points

2.2.2 Thermochemical Conversion Research and Development

Thermochemical Conversion R&D focuses on developing technology that converts biomass first to a liquid, vapor, or gaseous intermediate and then to a fuel or other product. Pathways such as fast pyrolysis, catalytic fast pyrolysis (i.e., *ex situ* vapor phase upgrading or *in situ* vapor phase upgrading), hydrothermal liquefaction (HTL), solvent liquefaction, or hydropyrolysis yield a liquid or vapor intermediate known as a bio-oil. Gasification pathways produce a gaseous intermediate that primarily consists of carbon monoxide, carbon dioxide, and hydrogen. Bio-oils and gaseous intermediates can be further converted to finished fuels—such as gasoline, diesel, and jet fuels—or to other products, including home heating oil, waxes, liquid smoke, etc.

In general, pyrolysis processes convert biomass to condensable vapors, non-condensable gases, char, and coke in the absence of oxygen at elevated temperatures. Depending on the process conditions (such as the temperature, catalyst, and presence of a reductant), one or two liquid phases are formed upon quenching the condensable vapors. For example, a fast pyrolysis process results in a single-phase bio-oil with high water content, whereas a hydropyrolysis process results in a bio-oil phase and an aqueous phase. The bio-oil phase is upgraded through separations, hydroprocessing, and fractionation steps to produce petroleum refinery intermediate feedstock or finished fuels. The off-gases from the pyrolysis and upgrading steps may be used to generate process heat and power and to produce hydrogen for use in upgrading of the bio-oils. The aqueous phase may contain organic acids, aldehydes, ketones, and phenols, which also can be used to produce additional fuel precursors, hydrogen, or other products. The non-condensable gases are often recycled and used as fluidizing gas in the pyrolysis reactor. Char and coke can be used to produce process heat and power.

Other thermochemical conversion processes—such as solvent liquefaction (including HTL, a specific case where the solvent is water)—can convert high-moisture feedstocks to liquid bio-oils, char, and gases. These solvent liquefaction technologies are typically performed at higher pressures and lower temperatures than pyrolysis. Hydrothermal and solvent liquefaction technologies are well-suited for wet feedstocks such as algae because, unlike pyrolysis and gasification, they can tolerate high levels of moisture in the feedstock. As such, HTL R&D is an area of interface tasks between Thermochemical Conversion R&D and Algal Feedstocks R&D.

In contrast to conversion pathways that form a bio-oil intermediate, gasification processes form a gaseous intermediate, which could include synthesis gas (syngas) or synthetic natural gas. Syngas is composed primarily of hydrogen, carbon monoxide, and some carbon dioxide, and can be generated via gasification of biomass. Synthetic natural gas is composed primarily of methane and is generated by processes such as catalytic hydrothermal gasification or anaerobic digestion. Synthetic natural gas may also be obtained from landfill gas. Each of these gaseous intermediates may be further converted to fuels, chemicals, or other liquid intermediates via biological and/or catalytic processes.

Thermochemical Conversion Process Steps

The conceptual block flow diagram in Figure 2-25 outlines the main technologies or unit operations of thermochemical biomass-to-fuel processes for converting biomass to gasoline, diesel, and jet fuel.

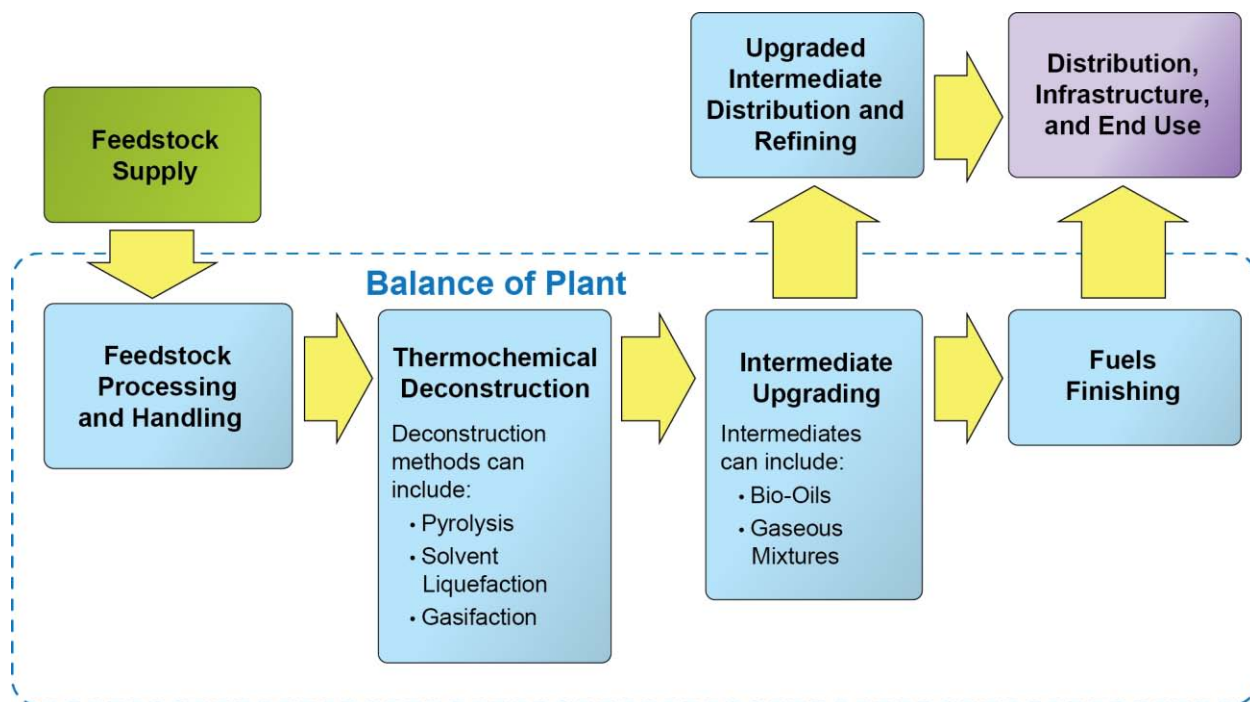

Figure 2-25: Thermochemical conversion process steps for biomass to biofuels

Feedstock Preprocessing and Handling: Feedstock preprocessing and handling includes preprocessing and formulating biomass to control particle size, porosity, and elemental composition. Feedstock characteristics are controlled, for example, through operations such as feedstock grinding, sizing, blending, densification, leaching, and/or torrefaction. Decisions about cost, quality, volume, and energy tradeoffs must be made between feedstock preprocessing and blending in the feedstock supply system versus within the conversion process. Most gasification and pyrolysis processes require further biomass drying, while solvent liquefaction approaches can use high-moisture biomass, such as whole, wet algae.

Thermochemical Deconstruction Processes: Thermochemical deconstruction of biomass involves heating biomass to achieve rapid thermal decomposition of a lignocellulosic feedstock. Process variables such as temperature, pressure, residence time, and the amount of oxygen in the reactor will determine if the intermediate formed is solid, liquid, or gas. These deconstruction processes are generally categorized as direct or indirect liquefaction.

Deconstruction to Form Bio-Oil Intermediates: In general, pyrolysis is the thermal and chemical decomposition of biomass without the introduction of oxygen to produce a bio-oil intermediate. Fast pyrolysis is typically performed at 375°C–550°C and atmospheric pressure and produces either a single- or two-phase liquid product (a bio-oil phase and an aqueous phase), along with gases and char. Generally, lower-temperature processes (375°C–450°C) form a single-phase liquid product, whereas higher-temperature processes, particularly when in the presence of reductants and/or catalysts, produce a

biphasic product. Catalytic fast pyrolysis and hydrolysis employ a catalyst during a vapor phase upgrading step to produce a biphasic product and a bio-oil phase with lower oxygen content than conventional fast pyrolysis. Other direct liquefaction technologies, such as hydrothermal or solvent liquefaction, can be used to deconstruct high-moisture feedstock directly to bio-oils, typically at higher pressures and lower temperatures than pyrolysis (250°C–350°C and 5–25 megapascal). Each of these deconstruction technology produces bio-oil with unique characteristics—including oxygen content, water content, carbon yield, and viscosity—that depend on the processing conditions and reactor type.

Deconstruction to Form a Gaseous Intermediate: Crude gaseous intermediates are produced by thermally deconstructing biomass (e.g., indirect liquefaction such as gasification or catalytic gasification), followed by gas cleanup and conditioning. Unlike pyrolysis processes, where no oxygen is introduced to the reactor, gasification processes require the addition of an oxygen carrier. For example, biomass gasification is a high-temperature conversion process that begins with the rapid thermal decomposition of a lignocellulosic feedstock. This is followed by partial oxidation or reforming of the resulting compounds with a gasifying agent or oxygen carrier—usually air, oxygen, or steam—to yield a gaseous intermediate (crude syngas). This all occurs in the same reactor within seconds. The crude gas composition and quality are dependent on a range of factors, including feedstock composition, type of gasification reactor, gasification agents, stoichiometry, temperature, pressure, residence time, and the presence or lack of endogenous or added catalysts.

Intermediate Upgrading: Thermochemical intermediates include crude bio-oils and gaseous intermediates.

Bio-Oil Intermediate Stabilization and Upgrading: Bio-oil stabilization and upgrading involves mitigating the effects of reactive compounds to improve storage and handling properties. This may encompass hydroprocessing, separation, and/or fractionation steps to remove water, coke, catalyst, char, and ash particulates, or other destabilizing components, such as metals and oxygenated species, from bio-oil. Hydrodeoxygenation (HDO) saturates unsaturated hydrocarbons and reduces the total oxygen and acid content, thereby increasing stability. Crude bio-oil must undergo one or more of these stabilization and upgrading steps before it can be processed to finished fuel specifications and fractionated into fuel cuts in either an existing petroleum refinery under conventional hydroprocessing conditions (e.g., high temperature and pressure) or in a standalone biorefinery.

Syngas Cleanup and Gaseous Intermediate Upgrading: Syngas cleanup is the removal of contaminants from crude biomass-derived synthesis gas. It involves an integrated multi-step approach that varies depending on the intended end use of the product gas. Gas cleanup normally entails removing or reforming tars and acid gas, ammonia scrubbing, capturing alkali metal, and removing particulates, followed by conditioning. Typical gas conditioning steps include sulfur polishing to reduce levels of hydrogen sulfide to acceptable amounts for fuel or product synthesis catalysts, and may require water-gas shift to adjust the final hydrogen-carbon monoxide ratio for optimized fuel or product synthesis. The required degree of gas cleanup and conditioning depends on the method used to convert the gas in subsequent process steps to a fuel.

Gaseous intermediate upgrading is the conversion of clean gaseous intermediates to fuels or mixed oxygenates via biological organisms (e.g., syngas fermentation) or catalytic processes (e.g., Fischer-Tropsch synthesis). The production of fungible liquid transportation fuels from these intermediates also yields high-value biobased products and chemicals. Because catalytic fuel synthesis is typically exothermic, heat recovery and temperature control are essential to maximize the process efficiency and catalyst life.

Fuel Processing: Fuel processing includes additional hydroprocessing needed to remove oxygen and other impurities to produce distillate range hydrocarbons that meet finished fuel specifications for gasoline, diesel, or jet fuel. Hydrocracking and separations (i.e., distillation) are also necessary to produce these various fuel cuts.

Balance of Plant: Balance of plant encompasses the process units and site operations that support the main biomass-to-fuel conversion steps. These operations may include hydrogen generation, emissions abatement, wastewater treatment, heat and power generation, and solid waste disposal, and some of these may represent a significant cost contribution to the final fuel cost. Cost reductions may be achieved through more efficient hydrogen and carbon usage (such as minimizing organics in the aqueous phase or char production), as well as improvements in process heat recovery, emission reductions, wastewater treatment, and process recycle streams.

Thermochemical Conversion Research and Development Interfaces

Analysis Interface: Conversion technologies are evaluated by TEA and LCA, necessitating interfaces between research analysis activities and the cross-cutting Strategic Analysis and Sustainability Technology Areas (see Sections 2.4 and 2.5). TEAs and LCAs performed within Thermochemical Conversion R&D inform strategic planning and document progress toward achieving the programmatic goals. Data on emission and energy and water use also inform the Office's sustainability analysis activities.

Terrestrial and Algal Feedstock Supply and Logistics Interface: The Feedstock Supply and Logistics R&D and Algal Feedstocks R&D Technology Areas develop feedstock preprocessing technologies that reduce inherent biomass variability to deliver feedstock that meets the specifications (composition, size, surface area, moisture content, inorganic content, etc.) of thermochemical conversion processes. This includes evaluating the impact on process efficiency and fuel production cost of using mechanically and/or chemically treated feedstock. Close coordination with the Feedstock Supply and Logistics Technology Areas (see Section 2.1) and Algal Feedstocks R&D (see Section 2.1.2) is required to (1) understand the tradeoffs between feedstock cost, quantity, and quality to meet the conversion specification requirements of the biorefinery; and (2) identify positive synergies to improve efficiencies and production costs.

Intermediate Distribution and Refining: Of the possible intermediates produced from thermochemical conversion, bio-oil intermediates present an opportunity to explore a variety of distribution and refining schemes. Three general distribution strategies are being explored. The first strategy involves fully upgrading to finished fuel specifications for gasoline, diesel, or jet fuel within an integrated biorefinery. The second strategy involves intermediate stabilization, which occurs at several distributed locations, and then stabilized intermediates are transported to a centralized upgrading biorefinery for fuel finishing to gasoline, diesel, and jet fuel

specifications (commonly referred to as the “hub and spoke” model). The third strategy involves production of stable, upgraded intermediates that are suitable for use in a petroleum refinery, thus leveraging existing infrastructure for fuel finishing. Information regarding the physiochemical properties, reactivities, and compatibilities of intermediates for fuel finishing are required to successfully implement any of these strategies.

Biofuels Distribution Infrastructure Interface: The next step in the supply chain is the distribution of the gasoline, diesel, or jet fuels for blending. In order for blending stations or refineries to accept them, biofuels have to meet regulated fuel specifications. Being officially certified by EPA for Renewable Identification Number credits also enhances the marketability of the fuel or intermediate. Biofuels properties, such as cetane and octane, as well as flash points, smoke points, cloud or pour points, and distillation curves, must be verified against established gasoline, diesel, and jet fuel specifications. Understanding the miscibility and other behavior of biofuels when blended with petroleum-derived fuels and fuel-handling systems/engines is particularly critical.

Demonstration and Deployment Interface: Demonstration of thermochemical processes in biorefineries can provide information relevant to scale-up and process integration. The information gained through validation at pilot, demonstration, and pioneer scales can be applied to processes being developed at smaller scales, especially impacts of conversion technologies on wastewater and heat and power integration. This information can identify R&D necessary to mitigate negative impacts and opportunities. Additionally, challenges encountered during demonstration can be addressed through R&D performed at bench and larger scale.

2.2.2.1 Thermochemical Conversion Research and Development Support of Office Strategic Goals

The strategic goal of Thermochemical Conversion R&D is to *develop commercially viable technologies for converting biomass into energy-dense, fungible, finished liquid fuels, such as renewable gasoline, jet, and diesel, as well as biochemicals and biopower.*

Activities in this area directly address and support the production of gasoline, diesel, and jet fuels from on-specification feedstock that may be comprised of algae; woody biomass; energy crops; agricultural residues; sorted, dry MSW (i.e., yard and construction waste); and other biomass. These conversion technologies also indirectly support the production of biochemicals and biopower.

2.2.2.2 Thermochemical Conversion Research and Development Support of Office Performance Goals

The overall performance goal of Thermochemical Conversion R&D is to reduce the projected mature technology processing costs for converting algae or lignocellulosic biomass to hydrocarbon fuels via a thermochemical pathway. A variety of thermochemical pathways via bio-oil intermediates or gaseous intermediates are being explored in the R&D portfolio, and they will continue to be assessed and reprioritized to achieve the Office's \$3/GGE performance goal in 2017, 2022, and 2030. There are and will be several design cases with cost targets and technical goals that outline how the Office might achieve this performance goal through RD&D over the near, mid, and long term. One specific example of a near-term thermochemical pathway is the Fast Pyrolysis and Hydrotreating Bio-Oil Pathway.⁵² This analysis established the following thermochemical conversion cost target:

- By 2017, achieve an nth plant modeled conversion cost of \$2.50/GGE via a thermochemical pathway. This contributes to a minimum gasoline and diesel blendstock fuel selling price of \$3.50/GGE in 2011 dollars.

A benchmark case of this goal is illustrated in the 2013 design report (Jones et al. 2013) for fast pyrolysis of on-specification woody feedstock followed by catalytic upgrading of the condensed vapors to produce gasoline and diesel blendstock fuel, as illustrated in Appendix B, Table B-5. The report builds upon Jones et al. (2009) and is updated with the most recent DOE national laboratory data, as well as publicly available experimental data from industry and universities.

Performance milestones for the thermochemical pathways under investigation are as follows:

- By 2014, establish out-year conversion cost projections and technical targets for achieving the \$3/GGE goal based on a TEA for at least one gaseous intermediate pathway that produces gasoline and diesel blendstock fuels.
- By 2015, select at least one thermochemical pathway for initially integrated operations to validate the Office's performance goal of \$3/GGE by 2017 by evaluating R&D data from bench-scale, semi-integrated thermochemical pathways that produce gasoline and diesel blendstock fuels.
- By 2017, validate the R&D performance goal of \$2.50/GGE nth plant modeled conversion cost and thus the Office's performance goal of \$3.00/GGE MFSP by performing integrated operations using on-specification feedstock via a thermochemical pathway that produces gasoline and diesel blendstock fuels.
- By 2020, select another thermochemical pathway for integrated operations to validate the 2022 Office performance goal of \$3/GGE by evaluating R&D data from bench-scale, semi-integrated thermochemical pathways that produce gasoline and diesel blendstock fuels.
- By 2022, validate the Office performance goal of \$3/GGE by performing integrated operations using on-specification blended, low-cost feedstock via a thermochemical pathway that produces gasoline and diesel blendstock fuels.

⁵² Jones, S. et al. "Process Design and Economics for the Conversion of Lignocellulosic Biomass to Hydrocarbon Fuels: Fast Pyrolysis and Hydrotreating Bio-Oil Pathway." PNNL-23053. (2013). Richland, WA: Pacific Northwest National Laboratory, http://www.pnnl.gov/main/publications/external/technical_reports/PNNL-23053.pdf.

2.2.2.3 Thermochemical Conversion Research and Development Technical Challenges and Barriers

The challenges and barriers listed in this section are specific to Thermochemical Conversion R&D. Additional challenges can be found in the Strategic Analysis section (2.4), the Sustainability section (2.5), and the Feedstocks Supply and Logistics section (2.1).

Tt-A. Feeding Dry Feedstock: Several variables impact the behavior of materials during in-feed into a conversion process, including feedstock type (and feedstock blend), format, and molecular composition (e.g., lignin concentration), as well as conversion reactor design and pressure. This variability makes reactor in-feed challenging and can impact conversion performance. The performance of dry feedstock formats and species needs to be evaluated, particularly in pressurized feeder systems, to reduce technical risks to process scale-up.

Tt-B. Feeding Wet Biomass: Improved processes are needed to feed whole, wet algal biomass slurries (of approximately 20%–30% solids in water) and wet cellulosic feedstocks into the liquefaction reactor, or for pumping lipids extracted from algae into upgrading systems. Determination of optimal operating conditions and economics of pumping systems is needed for whole, wet algae slurries and lipid-extracted algae oils.

Tt-C. Relationship between Feedstock Physical and Chemical Properties and Conversion Processes: Research is needed to map the relationship between the physical properties, the chemical composition of feedstocks, and the effects on the efficacy of a conversion process. Problematic chemical species, particle size, reactor type/geometry, and other factors need to be identified. Notable physical properties include thermal-specific heat, thermal diffusivity, bulk density, skeletal density, particle size/shape distributions, and mass diffusivities for product gases and liquids. These parameters greatly influence the temperature and chemical species distributions during the conversion process.

Tt-D. Biomass Pretreatment: Preprocessing operations are often necessary to address feedstock variability and to produce feedstocks that meet conversion quality needs. For instance, removing ash components in the feedstock may be important to preserving catalyst life and performance in downstream processing.

Tt-E. Deconstruction of Biomass Feedstocks to Form Gaseous Intermediates: This includes developing an understanding of indirect liquefaction (i.e., gasification) options and their chemistries for materials, including wood; energy crops; sorted, dry MSW; and agricultural residues high in minerals and lignin.

Tt-F. Deconstruction of Biomass to Form Bio-Oil Intermediates: Development of direct liquefaction technologies (including fast pyrolysis, catalytic fast pyrolysis, hydrolysis, or solvent liquefaction)—and process parameters to produce a higher bio-oil yield—are critical. Understanding the technical and cost tradeoffs for producing a higher-quality bio-oil versus a higher bio-oil yield from these various technologies is necessary for balancing severity and costs of upgrading steps. This includes testing these conversion technologies on various biomass blends and formats to understand the impact of feedstock characteristics on bio-oil yield and quality.

Tt-G. Gaseous Intermediate Cleanup and Conditioning: There is a need for gas cleaning and conditioning catalysts and technology that can cost effectively remove contaminants such as tars, particulates, alkali, sulfur, and other inorganics. The interactions between the catalysts used for gas cleanup and conditioning, and the gasification conditions and feedstock, need to be better understood. These interactions require careful attention to trace contaminants and are important for efficient cleanup and conditioning of syngas in conjunction with optimal lifetimes of the catalyst(s). These interactions are specific to each type of fuel synthesis catalyst.

Tt-H. Bio-Oil Intermediate Stabilization and Vapor Cleanup: Crude bio-oil is acidic and thermally unstable due to the presence of a complex mixture of reactive species like carboxylic acids, aldehydes, ketones, and olefins. Bio-oil is sensitive toward thermal degradation, and the viscosity is known to increase over time due to ill-defined condensation and polymerization reactions. Understanding the composition of bio-oil is critical for improving current cleanup, stabilization, and upgrading processes. In particular, higher molecular weight components of bio-oil, which can be highly detrimental to the stability of the bio-oil, cannot be characterized by current methods. Knowing the types of intermediates that are formed and their rates of formation as a function of reaction conditions will aid in identifying optimum bio-oil production and upgrading technologies. In addition to better characterization and understanding of the composition of bio-oil, catalytic reactions, separations technologies, and other processes need to be developed to generate stabilized bio-oils that are compatible with known upgrading technologies.

Tt-I. Catalytic Upgrading of Gaseous Intermediates to Fuels and Chemicals: New, more durable technologies and processes are needed for converting biomass-derived syngas into fuels and chemicals. The Office's prior success in producing mixed alcohol streams from biomass syngas illustrated that commercial-scale production of fungible hydrocarbon liquids is still limited by a variety of factors, including poor selectivity, low product yields, and catalyst deactivation. More robust processes and catalysts (chemical and biological) are needed for producing mixed alcohols, olefins, and alkanes. Significant efforts are needed to develop and improve processes and catalysts that can produce hydrocarbon fuels and chemicals and meet reasonable performance targets and commercially viable capital and operating costs. Desirable improvements include increased productivity and selectivity; extended catalyst lifetimes (in high- and low-temperature environments); and process intensification/smaller scales that are cost effective and commensurate with biomass feedstock supply.

Tt-J. Catalytic Upgrading of Bio-Oil Intermediates to Fuels and Chemicals: The number of hydrotreating steps needed to meet a finished fuel specification depends on the quality of the bio-oil after the initial upgrading step. In this context, the bio-oil could be the result of a fast pyrolysis process or triglyceride refining of extracted algal oils after solvent separations. Hydrotreating catalysts that are highly selective to desired end products and are stable in the presence of impurities are ideal. Bio-oils may be upgraded to varying degrees, allowing several entry points within petroleum refineries for fuel finishing.

Developing and optimizing catalysts used in the first stage of upgrading, whether in liquid phase or vapor phase, for improved bio-oil quality and yield is critical. Greater understanding is needed regarding the tradeoffs between the amount and quality of bio-oil produced after HDO and the impact on additional downstream catalytic hydroprocessing steps required to meet a finished fuel or refinery feedstock specification. The primary objective is to design catalysts and catalyst

regeneration systems that reduce costs by maximizing catalyst life, stability, productivity rates, and yields. Understanding catalyst coking and contamination issues is essential.

Tt-K. Product Finishing: After hydroprocessing, the fuel intermediates are fractionated or distilled to light molecules (~C4), naphtha, distillates, and heavy oil (if any). If heavy oil fractions are present, hydrocracking processes are necessary to convert these molecules to fuel cuts. Distillation technologies are commercially available; however, jet and diesel cetane, gasoline octane, flash point, smoke points, cloud or pour points, and distillation curves must be verified to determine that hydrocarbon fuel products meet necessary finished fuel specifications. It is also critical to understand and determine bio-oil requirements for fuel finishing within petroleum refineries, as well as understand the limitations of the distribution infrastructure.

Tt-L. Knowledge Gaps in Chemical Processes: Understanding the fundamental chemical processes that occur during biomass feedstock deconstruction and intermediate upgrading can inform technology breakthroughs and drive optimization. These improvements target increasing carbon, hydrogen, separations, and energy efficiencies. For example, a fundamental understanding of reaction mechanisms and kinetics using tools such as computational modeling can enable improvements to catalyst design, process configuration, and reactor design.

Tt-M. Hydrogen Production: Hydrogen production is essential for all thermochemical pathways. It is presumed that off-gases from thermochemical deconstruction and upgrading steps—as well as wastewater treatment—could be sent to a conventional hydrogen production plant that may consist of a steam reformer, water-gas shift reactor, pressure swing absorption unit, and heat recovery. Improvements to hydrogen recovery and production can lower the hydrogen cost contributions to fuels produced from each pathway.

Tt-N. Aqueous Phase Utilization and Wastewater Treatment: The aqueous phase from thermochemical deconstruction and upgrading may contain organic acids, aldehydes, ketones, and phenolics. Research is needed to characterize organics in the aqueous phase and to convert these organics to hydrogen, biochemicals, or hydrocarbon fuels. Alternative wastewater treatment should also be explored, such as catalytic hydrothermal gasification.

Tt-O. Separations Efficiency: Improvements are needed in a variety of separations technologies that can assist in vapor or gas phase cleanup; bio-oil stabilization; removing contaminants; preventing fouling; reducing the severity of upgrading steps; protecting catalysts from poisoning; catalyst regeneration; aqueous phase reforming; hydrogen production; and nutrient recycling. This may include processes such as solid/gas separation (e.g., hot gas filtration), solids/liquid separation, gas/liquid separation, and liquid/liquid separation. In the case of HTL of whole algae, filtering of the reactor effluent is an essential means of solids recovery to recycle nutrients back to the algae ponds.

Tt-P. Materials Compatibility: Due to the highly oxygenated nature of biomass-derived intermediates, materials that were designed for use with petroleum-derived intermediates might not be appropriate for biomass-derived intermediates. For instance, at relatively low temperatures (50°C), crude bio-oil can be corrosive to common structural materials like carbon steel. Corrosion of storage tanks, transport facilities, etc., could result if bio-oil is not processed sufficiently. Thus, it is critical to study the corrosive nature of bio-oil upgraded to varying

degrees to reduce the corrosive nature of bio-oil to a level that is compatible with storage options.

Tt-Q. Sensors and Controls: Effective process control will be needed to maintain plant performance and regulate emissions at target levels with varying load, fuel properties, and atmospheric conditions. Commercial control systems need to be evaluated for thermochemical processes and the presence of chemical species, and new systems need to be developed where necessary.

Tt-R. Process Integration: Process integration currently presents large engineering scale-up risks because of the lack of operational data on fully integrated systems over extended periods of time that would be required for successful commercialization. The effect of feed and process variations must be understood to avoid fouling, plugging, corrosion, or other disruptions in biorefinery operations. Process integration is essential for (1) characterizing the complex interactions that exist between unit operations, (2) identifying impacts of trace components on catalytic and thermal systems, and (3) enabling the generation of predictive engineering models that can guide process optimization or scale-up efforts and enable process control.

Tt-S. Petroleum Refinery Integration of Bio-Oil Intermediates: Producing a bio-oil intermediate suitable for use in one or more insertion points within a petroleum refinery (e.g., hydrotreaters, reformers, fluid catalytic crackers, cokers, isomerization units, or hydrocrackers) provides a unique opportunity to leverage existing infrastructure for fuel finishing. Information is needed about the physiochemical properties, reactivities, and compatibilities of bio-oil intermediates for fuel finishing within an existing petroleum refinery. This requires obtaining direct input from a refinery regarding the chemical and physical specifications required for an acceptable bio-oil feedstock. An analysis of compatibility with materials of construction is also necessary. The market potential of bio-oils as a feedstock for petroleum refineries is largely unknown. There is a need to gather information to understand the technical risks and to illustrate the economics and sustainability of integration so that refineries will consider the bio-oil intermediate an acceptable refinery feedstock.

Tt-T. Heat Integration and Power Generation: Off-gases that are not needed for hydrogen generation are typically sent to a boiler for combustion (occasionally along with char) to generate superheated steam for a turbine. Steam could be extracted from the turbine for process use, or a lower-pressure boiler could be used to solely generate process steam. Depending on the overall plant configuration, power demand in the conversion plant might be balanced by either purchasing or selling electricity to the grid.

2.2.2.4 Thermochemical Conversion Research and Development Approach for Overcoming Challenges

The R&D approach for overcoming the key thermochemical conversion technical challenges and barriers is outlined in the WBS depicted in Figure 2-26.

The Office's current Thermochemical Conversion activities generally fall into seven broad groupings:

- *Analysis and Sustainability*: To understand the impact of technologies with respect to environmental sustainability, economic metrics, and the current SOT
- *Feedstock Interface Activities*: To understand the impact of feedstock quality on conversion efficiency and economics
- *Deconstruction Processes*: To produce useful intermediates from biomass
- *Upgrading Processes*: To convert intermediates to fuels and chemicals
- *Integration and Intensification*: To optimize for systems-level performance
- *Conversion Enabling Technologies*: To apply new knowledge and tools to innovate beyond current conversion technologies
- *Validation*: To demonstrate technical, sustainability, and economic improvements in an integrated process setting.

Thermochemical Conversion R&D investments include a variety of deconstruction and upgrading technologies to produce gasoline and diesel blendstock fuels, as well as chemicals or heat and power. R&D to overcome the related challenges is performed by DOE national laboratories, industry, nonprofits, and universities.

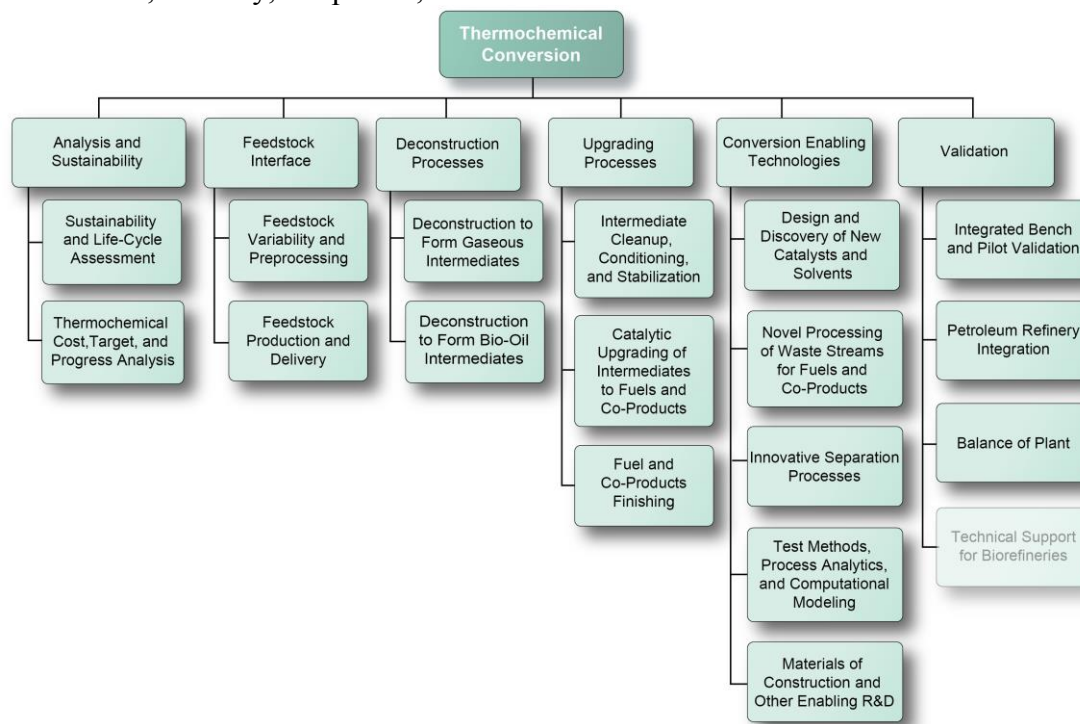

Figure 2-26: Thermochemical conversion R&D work breakdown structure

The WBS illustrated in Figure 2-26 is described below. Table 2-9 summarizes each task element's work as it relates to specific R&D activities, challenges, and DOE-funded performers.

Analysis and Sustainability

Modeled, integrated conversion process designs are developed to assess techno-economic feasibility, establish and measure progress toward technical performance targets, evaluate environmental sustainability metrics, and improve sustainability of each feasible bio-oil pathway. Environmental sustainability metrics include lifecycle greenhouse gas emissions, fossil energy consumption, consumptive water use, wastewater generation, air pollutants, biomass carbon-to-fuel efficiency, and total fuel yield. Experimental data are obtained from DOE-funded R&D projects (including the DOE national laboratory user facilities) and publicly available sources to monitor progress and direct future research efforts. Techno-economic and process data from integration and scale-up efforts can be used to validate existing models, inform SOT updates, and verify the accuracy of modeled cost projections.

Feedstock Interface

For biorefineries, it is important that feedstock specifications are met while balancing feedstock processing within total system cost. Specifically, the key challenges will be to stabilize and efficiently transport and handle biomass, as well as economically preprocess biomass to the required specifications to enable process optimization. Research activities address feedstock issues occurring within the biorefinery plant boundaries, such as feedstock handling, preprocessing, and reactor in-feed. Relevant feedstock interface R&D for the production of biofuels may also be utilized by biopower technologies. Feedstock interface tasks address the challenge of feedstock supply and quality by assessing the benefits of mechanically and chemically treated, formulated biomass. This includes development of feedstock logistics systems that sustainably supply feedstock of the appropriate specification to the biorefinery, while balancing conversion yield and quality with feedstock costs. To do this, it is necessary to understand the downstream conversion impact of various biomass components, such as ash, bark, and moisture content.

Deconstruction Processes

Improved technologies are needed for thermochemical deconstruction of biomass to form a gaseous or bio-oil intermediate. To fully realize the benefits of an integrated biorefinery, robust and cost-effective biomass thermal conversion processes are under development that can convert a variety of biomass materials to suitable clean and high-quality intermediates for subsequent conversion to biofuels, biochemicals, or biopower. Maintenance of catalyst activity is particularly important with feedstocks containing sulfur or other inorganic content (e.g., N, P, K, O, Cl, Ca, Na, Si, etc.).

Upgrading Processes

Once a crude bio-oil or syngas is produced, technologies for cleanup, conditioning, and/or stabilization are needed for upgrading to a finished fuel or co-product. This involves mitigating reactive compounds to improve storage and handling properties. Bio-oil upgrading processes include the removal of water, char, and ash particulates, as well as destabilizing components

such as metals and oxygenated species. Specifically for bio-oils, hydroprocessing and similar thermal-catalytic processing techniques reduce the total oxygen and acid content, thereby increasing stability. This processing is required before a bio-oil intermediate can be upgraded under conventional hydroprocessing conditions (e.g., high temperature/pressure) in a standalone biorefinery, or before it can become a suitable feedstock for a petroleum refinery. For syngas, cleanup normally entails removing or reforming tars and acid gas, ammonia scrubbing, capturing alkali metal, and removing particulates. Typical gas conditioning steps include sulfur polishing (to reduce levels of hydrogen sulfide to acceptable amounts for fuel synthesis) and water-gas shift (to adjust the final hydrogen-carbon monoxide ratio for optimized fuel synthesis).

Conversion Enabling Technologies

The advancement of thermochemical conversion pathways requires the development of next-generation catalysts and solvents; separations technologies; hydrogen production; aqueous phase reforming; and other, yet-to-be-discovered technology breakthroughs. Fundamental understanding of reaction mechanisms and kinetics of conversion processes using tools such as computational modeling can enable these improvements. New knowledge informs the development of processes that are more energy, carbon, and hydrogen efficient (and thus cost efficient). Complementary to the enabling technology of catalysis are advances in the biomass pretreatment technologies that will improve feedstock logistics and the accessibility of the biomass molecular moieties to subsequent conversion processes. Advanced pretreatment will enable greater yield and quality of biomass intermediates and biofuels, thus improving energy efficiency. This work bridges the gap between discoveries made by DOE's Office of Science, ARPA-E, and the National Science Foundation, with applied R&D conducted by DOE's Bioenergy Technologies Office.

Validation

Demonstrating that improved thermochemical conversion and upgrading technologies are cost competitive with their petroleum-based counterparts for producing finished fuels is critical to advancing thermochemical conversion pathways. This includes processing bio-oils in an existing petroleum refinery to make finished fuels. The Office leverages industry feedback to understand emerging issues and R&D opportunities. Integration and scale-up efforts are at the bench and pilot scale and generate data that are used to assess progress against technical and cost targets, as well as environmental sustainability metrics. The operational data are also used to model nth plant costs and technical projections for each thermochemical conversion pathway.

Table 2-9: Thermochemical Conversion R&D Activity Summary

WBS Element	Description	Barrier(s) Addressed
Analysis and Sustainability	Develop, refine, and utilize life-cycle and process engineering/TEAs for priority and alternative thermochemical conversion routes. <ul style="list-style-type: none"> - Evaluate and identify performance improvements to technology pathways with respect to sustainability metrics. - Develop and update process analyses, design cases, and annual assessments of SOT for biochemical and hybrid processing routes to hydrocarbon fuels and biobased chemicals. 	Tt-R: Process Integration At-C: Data Availability across the Supply Chain St-C: Sustainability Data across the Supply Chain St-D: Implementing Science-Based Indicators and Methodology for Evaluating and Improving Sustainability St-E: Best Practices and Systems for Sustainable Bioenergy Production
Feedstock Interface	Develop feedstock specifications and processing systems that accommodate feedstock variability and are optimized for convertibility. <ul style="list-style-type: none"> - Understand feedstock variability (temporal, seasonal), logistics, and preprocessing intermediates (recalcitrance), and develop options for mitigating impacts on downstream conversion technologies, as well as the associated costs. - Define and produce on-spec materials for conversion testing based on feedstock characterization and preprocessing tools developed in the feedstock platform. 	Ft-G: Biomass Material Properties and Variability Ft-H: Biomass Physical State Alteration Tt-A: Feeding Dry Biomass Tt-B: Feeding Wet Biomass Tt-C: Relationship between Feedstock Physical and Chemical Properties and Conversion Processes Tt-D: Biomass Pretreatment St-C: Sustainability Data across the Supply Chain
Deconstruction Processes	Develop technologies for converting biomass into bio-oil or syngas intermediates for subsequent upgrading into fuels and chemicals. <ul style="list-style-type: none"> - Develop gasification technologies. - Develop pyrolysis technologies. - Develop solvent or HTL technologies. 	Tt-E: Deconstruction of Biomass to Form Gaseous Intermediates Tt-F: Deconstruction of Biomass to Form Bio-Oil Intermediates Tt-L: Knowledge Gaps in Chemical Processes Tt-P: Materials Compatibility St-C: Sustainability Data across the Supply Chain
Upgrading Processes	Develop technologies for cleanup, conditioning, and/or stabilization of an intermediate bio-oil or syngas for upgrading to a finished fuel or co-product. <ul style="list-style-type: none"> - Develop gas cleanup technologies. - Develop bio-oil stabilization technologies. - Develop improved catalysts for hydrotreating. - Improve catalysts for fuels synthesis. - Explore new and/or improved reactor designs. 	Tt-G: Gaseous Intermediate Cleanup and Conditioning Tt-H Bio-Oil Intermediate Stabilization and Vapor Cleanup Tt-I: Catalytic Upgrading of Gaseous Intermediates to Fuels and Chemicals Tt-J: Catalytic Upgrading of Bio-Oil Intermediates to Fuels and Chemicals Tt-K: Product Finishing
New Conversion Enabling Technologies	Develop new technologies that either improve known conversion processes or lead to the development of new conversion processes. <ul style="list-style-type: none"> - Understand reaction mechanisms. - Design and discover new catalysts. - Optimize aqueous phase utilization. - Explore novel separation technologies. - Explore novel hydrogen production technologies. - Develop advanced pretreatment technologies. 	Tt-L: Knowledge Gaps in Chemical Processes Tt-M: Hydrogen Production Tt-N: Aqueous Phase Utilization and Wastewater Treatment Tt-O: Separations Efficiency Tt-P: Materials Compatibility
Validation	Validate the sustainability and technical improvements of the integrated conversion technologies for the priority pathways. <ul style="list-style-type: none"> - Conduct integrated operations to validate thermochemical conversion pathways. - Produce a bio-oil intermediate suitable for use in one or more insertion points within a petroleum refinery for fuel finishing. - Assess progress against technical and cost targets, as well as environmental sustainability metrics. 	Tt-P: Materials Compatibility Tt-Q: Sensors and Controls Tt-R: Process Integration Tt-S: Petroleum Refinery Integration of Bio-Oil Intermediates Tt-T: Heat Integration and Power Generation St-C: Sustainability Data across the Supply Chain

2.2.2.5 Prioritizing Thermochemical Research and Development Barriers

In order to achieve the Thermochemical Conversion R&D goals, all of the challenges and barriers discussed in Section 2.2.1.4 need to be addressed. However, the following issues are critical and will be emphasized within near- to mid-term Thermochemical Conversion R&D efforts:

- Understand the relationship between feedstock quality and conversion
- Develop strategies for conserving carbon and hydrogen in conversion and upgrading processes
- Enable high-performance separations technologies to improve yields
- Work with petroleum refiners to address integrating biofuels into refinery processes.

Prioritization of R&D to overcome technical challenges is based on periodic evaluation of the Thermochemical Conversion R&D portfolio, as well as information on technologies being developed without government involvement. Annual technology assessments are conducted to help prioritize which thermochemical pathways support achievement of Office goals. Over the longer term, R&D is focused on validating additional biomass feedstock and innovative conversion processes to maximize biofuels production potential.

To this end, additional TEAs are being conducted to more accurately reflect the Office's diverse R&D portfolio, which includes other thermochemical pathways to produce hydrocarbon fuels.⁵³ These TEAs, combined with other criteria such as environmental performance, will help the program reprioritize the development of additional design cases for new, innovative conversion pathways. Periodic evaluations also serve as “on ramps” and “off ramps” for conversion pathways. Additionally, qualitative public input through stakeholder workshops (such as the Conversion Technologies for Advanced Biofuels Workshop held in December 2011) and the biennial Peer Reviews informs research priorities.⁵⁴

Thermochemical Conversion R&D is focused on validating additional feedstock blends and innovative conversion processes that can meet long-term cost goals and maximize the volume of U.S. biomass resources that can be accessed for biofuels production. Other potential thermochemical pathways under development within the program portfolio and in the private and academic sectors may contribute to meeting program performance goals. As such, the performance milestones discussed in this section involve periodic evaluation of the entire technology landscape to reprioritize the thermochemical pathways that could support 2017 and 2022 cost goals. These periodic evaluations will serve as “on ramps” and “off ramps” for thermochemical pathways, based on techno-economic and environmental performance assessments that use credible experimental data.

⁵³ http://www1.eere.energy.gov/bioenergy/m/technology_pathways.html

⁵⁴ U.S. Department of Energy. (2013). “Conversion Technologies for Advanced Biofuels Workshop Report.” Washington, D.C.: Government Printing Office. Manuscript in preparation.

The recently updated fast pyrolysis design report⁵⁵, which uses a blended, formatted woody biomass to produce gasoline and diesel blendstock fuel in 2017, is an example of how the \$3/GGE cost goal can be achieved by 2017, as illustrated in Figure 2-27 and Table 2-10. Relevant environmental sustainability metrics are outlined in Table 2-11. More details are provided in Appendix B, Table B-5.

This is only one example of how the Office could achieve the \$3/GGE goal. Two more design reports are anticipated in 2014 as example thermochemical pathways with the potential to achieve the Office \$3/GGE performance goal. The design reports include conversion cost projections and technical targets, as well as environmental sustainability metrics. The reports have been peer reviewed, and they are or will be made public. Annual SOT updates will be conducted to track progress toward the Office's \$3/GGE goal.

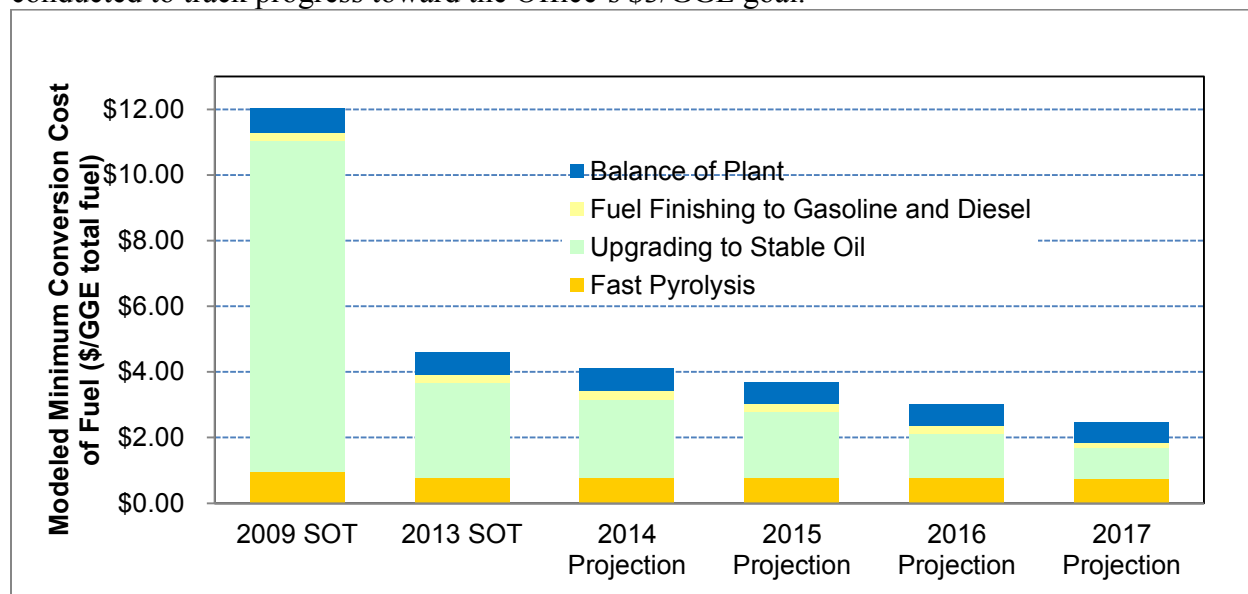

Figure 2-27: Conversion of woody feedstocks to renewable gasoline and diesel-finished fuels via fast pyrolysis

Based on the 2013 design report for fast pyrolysis, Figure 2-25 shows that a total potential cost reduction of 80% can be achieved between 2009 and 2017 with improvements in all four R&D areas listed. The projections are modeled nth plant production costs assuming a 2,000 dry tonnes feedstock per day, using both publicly available data and experimental data from the national laboratories for bench-scale fast pyrolysis and subsequent hydrotreating. More details behind this fast pyrolysis design case are provided in Appendix B, Table B-5.

⁵⁵ S. Jones, E. Tan, J. Jacobson, et.al. "Process Design and Economics for the Conversion of Lignocellulosic Biomass to Hydrocarbon Fuels Fast Pyrolysis and Hydrotreating Bio-oil Pathway." PNNL-23053, NREL/TP-5100-61178. (2013) Pacific Northwest National Laboratory, National Renewable Energy Laboratory, and Idaho National Laboratory. http://www.pnnl.gov/main/publications/external/technical_reports/PNNL-23053.pdf

Table 2-10: Conversion of Woody Feedstocks to Renewable Gasoline and Diesel Finished Fuels via Fast Pyrolysis (Does not include feedstock cost)

	2009 SOT		2013 SOT	2014 Projection	2015 Projection	2016 Projection	2017 Projection
Conversion Contribution (\$/gal gasoline)	\$12.40		\$4.51	\$4.02	\$3.63	\$2.96	\$2.44
Conversion Contribution (\$/gal diesel)	\$13.03		\$5.01	\$4.46	\$4.03	\$3.29	\$2.70
Conversion Contribution (\$/GGE total fuel)	\$12.02		\$4.60	\$4.09	\$3.69	\$3.01	\$2.47
Fast Pyrolysis (\$/GGE total fuel)	\$0.97		\$0.78	\$0.78	\$0.77	\$0.76	\$0.76
Upgrading to Stable Oil (\$/GGE total fuel)	\$10.07		\$2.88	\$2.39	\$2.01	\$1.35	\$0.95
Fuel Finishing to Gasoline and Diesel (\$/GGE total fuel)	\$0.25		\$0.25	\$0.25	\$0.24	\$0.24	\$0.14
Balance of Plant (\$/gge total fuel)	\$0.74		\$0.68	\$0.68	\$0.67	\$0.66	\$0.63

In addition to setting technical targets and cost projections, the Office is assessing the environmental performance of conversion pathways to enable continual evaluation and improvement of the designs throughout the technology R&D phase. The following environmental sustainability considerations are currently being assessed: greenhouse gas emissions, fossil energy consumption, fuel yield, biomass carbon-to-fuel efficiency, water consumption, and wastewater generation. Table 2-11 shows the estimated metric values for the conversion plant for the updated fast pyrolysis and upgrading design case.⁵⁶ This set of environmental sustainability metrics is not intended to be all-inclusive and will be expanded and updated as more experimental data become available. Work is in progress to quantify additional metrics, including criteria air pollutants and wastewater quality. The refined analysis will enable the Office to establish targets for environmental sustainability metrics to guide their improvement alongside the TEA. See Section 2.4 for more information on the Office’s approach to establishing environmental sustainability targets.

⁵⁶ S. Jones, E. Tan, J. Jacobson, et.al. “Process Design and Economics for the Conversion of Lignocellulosic Biomass to Hydrocarbon Fuels Fast Pyrolysis and Hydrotreating Bio-oil Pathway.” PNNL-23053, NREL/TP-5100-61178. (2013). Pacific Northwest National Laboratory, National Renewable Energy Laboratory, and Idaho National Laboratory, http://www.pnnl.gov/main/publications/external/technical_reports/PNNL-23053.pdf. See also Appendix B.

Table 2-11: Environmental Sustainability Metrics for Fast Pyrolysis and Upgrading

Environmental Sustainability Metric	2009 SOT ¹	2012 SOT	2013 SOT	2017 Projection
Greenhouse Gases (g CO ₂ -e/MJ fuel)—(fossil emissions; biogenic emissions) ²	22.1; 104	19.8; 104	20.5; 85	18.9; 85
Fossil Energy Consumption (MJ fossil energy/MJ fuel product) ³	0.326	0.294	0.321	0.301
Total Fuel Yield (gal/dry ton wood; GGE/dry ton wood)	74; 78	74; 78	84; 87	84; 87
Carbon-to-Fuel Efficiency (C in fuel/C in biomass)	38%	38%	47%	47%
Water Consumption (m ³ /day; gal/GGE) ⁴	998; 1.5	998; 1.5	1124; 1.5	1050; 1.4
Wastewater Generation (m ³ /day; gal/GGE) ^{4,5}	917; 1.4	917; 1.4	948; 1.3	932; 1.3

Table Notes:

1. The only difference between the 2009 and 2012 SOT cases is a decrease in hydrotreating catalyst consumption for the 2012 SOT.
2. Biogenic emissions include those contained in the char combustor exhaust, the waste heat from which is used for biomass drying.
3. Fossil energy consumption does not include grinding of the feedstock prior to the pyrolysis step.
4. Water consumption and wastewater generation values consider only direct water inputs and wastewater generated at the plant and do not include water associated with upstream production of materials and energy used at the plant. Water makeup is needed to replace steam consumed in the methane reforming process (for hydrogen production), blowdown from the steam and cooling water systems, and evaporation and drift from the cooling towers. It is assumed that steam blowdown is recycled to the cooling system, thereby significantly reducing the cooling water makeup for the plant.
5. Wastewater generation includes both wastewater from hydrotreating and blowdown from the cooling towers.

The environmental sustainability metrics fit within the framework of sustainability indicators published by Oak Ridge National Laboratory,^{57, 58} which covers the entire biomass supply chain. The metrics will be used to complete a full supply chain analysis for the pathway using Argonne National Laboratory's GREET model (the Greenhouse Gases, Regulated Emissions, and Energy Use in Transportation model) and water footprint model.

While the Energy Independence and Security Act of 2007 required EPA to conduct its own greenhouse gas assessments to determine fuel qualification, it is essential that LCA be performed during the development of these pathways in order to predict and facilitate improvement of environmental performance. This will enable conversion technologies to meet legislated goals, such as greenhouse gas reductions required by the Renewable Fuel Standard, and achieve other social and environmental benefits.

⁵⁷ A. McBride, V.H. Dale, L. Baskaran, M. Downing, L. Eaton, R.A. Efroymson, C. Garten, K.L. Kline, H. Jager, P. Mulholland, E. Parish, P. Schweizer, and J. Storey (2011). "Indicators to support environmental sustainability of bioenergy systems." *Ecological Indicators* 11(5), pp. 1277–1289.

⁵⁸ R.A. Efroymson, V.H. Dale, K.L. Kline, A.C. McBride, J.M. Bielicki, R.L. Smith, E.S. Parish, P.E. Schweizer, D.M. Shaw (2012). "Environmental indicators of biofuel sustainability: What about context?" *Environmental Management*, DOI 10.1007/s00267-012-9907-5.
http://web.ornl.gov/sci/ees/cbes/Publications/Efroymsonetal2012biofuelindicatorcontextEMfinal10%201007_s00267-012-9907-5.pdf

2.2.2.6 Thermochemical Conversion Research and Development Milestones and Decision Points

The key milestones and decision points to complete the tasks described in Section 2.2.2.1.4 are summarized in Figure 2-28.

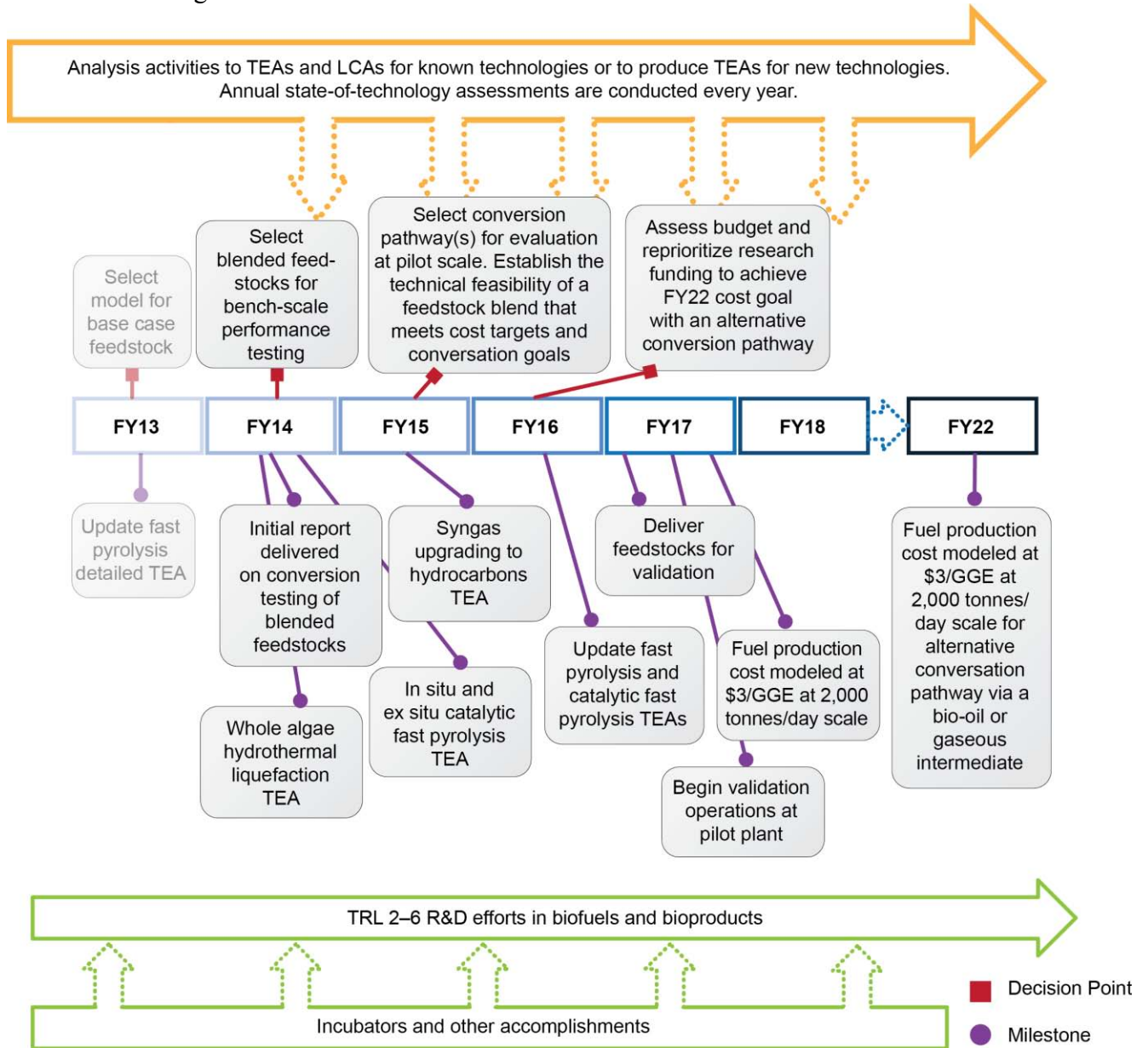

Figure 2-28: Thermochemical Conversion R&D key milestones and decision points

2.3 Demonstration and Deployment

The Demonstration and Deployment (D&D) goal is to de-risk bioenergy production technologies through validated proof of performance at the pilot, demonstration, and pioneer scales and to remove any additional barriers to commercialization. This is achieved through public-private partnerships that build and operate integrated biorefineries (IBRs) and through projects focused on infrastructure and end-use market barriers. These activities are essential to resolve key issues in the construction and scale-up of IBR systems, primarily by reducing risk to help overcome the commercial financing barriers that are currently facing the bioenergy industry. By creating a pathway to market, D&D helps address the final links of the bioenergy supply chain and works to enable a robust demand for end products.

The advanced bioenergy industry includes production of biofuels, bioproducts, and biopower. Similar to other process industries, the advanced bioenergy industry faces significant challenges and risks in the scale-up to pilot, demonstration, and pioneer scales. These include risks related to technology, construction, environmental impact, feedstock supply, operations, market offtake, and financing.⁵⁹ The specific risks of feedstock supply and market offtake are more pronounced for advanced biofuels than other renewable sources of energy because of the variability inherent in biomass and the lack of long-term offtake agreements in the fuel and chemicals markets. Advanced infrastructure-compatible fuels require an extra level of certification for end use, such as in automotive and jet engines, as well as infrastructure compatibility testing for integration into refinery equipment, pipelines, rail cars, and storage tanks. D&D activities are targeted to reduce these barriers for the private sector by facilitating large-scale projects that address these risks and further catalyze the desired transformation in the U.S. transportation fuel supply from fossil-based to renewable.⁵⁹

The Office is uniquely positioned to leverage both its legislative authority for financial assistance and DOE's successful track record in technology commercialization to assist developers through validated proof of performance at pilot, demonstration, and pioneer scales. A recent study that assumed a standard biorefinery size of 40 million gallons of ethanol equivalent fuel per year determined that meeting the goals of the Energy Independence and Security Act of 2007 will require more than 500 new biorefineries.⁶⁰ Of the approximately 200 U.S. companies currently working to develop advanced biofuels, only a fraction have progressed beyond in-house laboratory or very small-scale pilot testing.⁶¹ Of these, an even smaller number have been able to raise the funds to move into the full pilot or demonstration phase of development without some form of government financial assistance.⁶² During the Office's May 2013 Peer Review, experts

⁵⁹ Koonin, S.E., Gopstein, A.M. "Accelerating the Pace of Energy Change." *Issues in Science and Technology*, Winter 2011.

⁶⁰ U.S. Department of Agriculture. (2010). "USDA Biofuels Strategic Production Report." http://www.usda.gov/documents/USDA_Biofuels_Report_6232010.pdf.

⁶¹ Advanced Ethanol Council. (2012). "Cellulosic Biofuels Industry Progress Report 2012-2013." http://ethanolrfa.3cdn.net/d9d44cd750f32071c6_h2m6vaik3.pdf.

⁶² Bacovsky, D., Ludwiczek, N., Ognissanto, M., Wörgetter, M. (2013). "Status of Advanced Biofuels Demonstration Facilities in 2012: A Report to IEA Bioenergy Task 39." http://demoplants.bioenergy2020.eu/files/Demoplants_Report_Final.pdf.

from the refining, chemical, and financial industries made similar conclusions, stating that “the use of grants is necessary for reducing capital investment; providing project credibility; and providing a path for demonstrating technology proof of concept and market viability.”⁶³

The D&D Technology Area is investigating high-potential feedstock resources, including agricultural and forest residues; herbaceous and woody energy crops; sorted, dry MSW; and algal feedstocks and intermediates. D&D also investigates a wide range of conversion pathways, including biochemical, thermochemical, and hybrid processes; advanced anaerobic digestion; and other waste-to-energy technologies. Potential product slates include biofuels, renewable home heating oil, and other bioproducts, such as succinic acid, that can replace petroleum-based products made from oil. Each of these alternative resources and conversion pathways must be proven and validated at larger scales in order to sufficiently reduce risk and reach market acceptance.

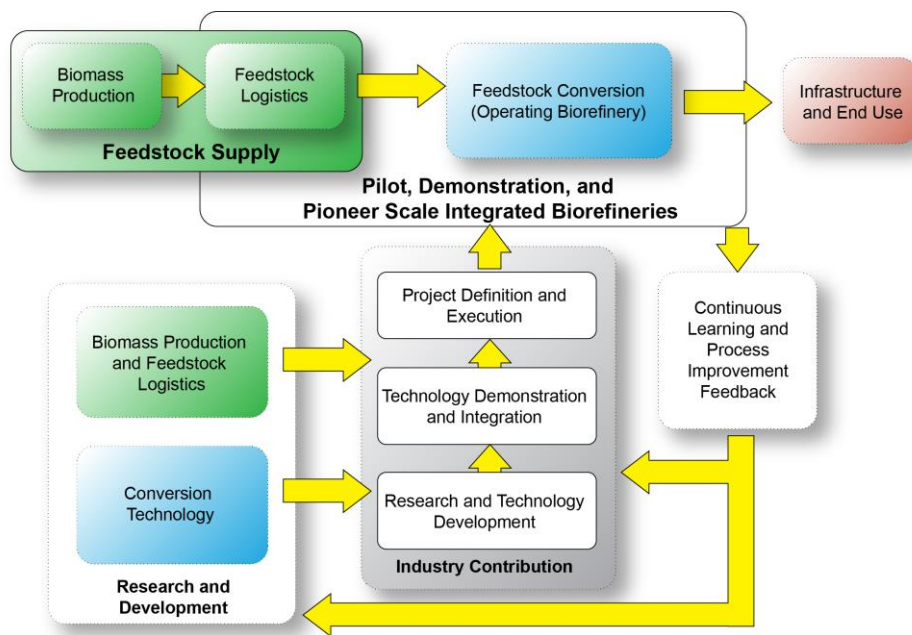

Figure 2-29: D&D technology area scope and connection to R&D efforts

Integrated Biorefinery Definitions and Objectives

An IBR facility is defined by its objectives and operational scale. A large group of stakeholders developed these definitions, including biomass suppliers; technology developers; engineering, procurement, and construction (EPC) companies; and financial firms such as venture capitalists, angel investors, and large commercial banks.

Pilot-scale facilities verify the integrated technical performance of the given suite of technologies from feedstock in through product out at production capacities equal to or greater

⁶³ Bioenergy Technologies Office. (2014). “2013 Peer Review Report.” DOE/EE-1014. Washington, D.C.: U.S. Department of Energy. p. 609. http://www1.eere.energy.gov/bioenergy/pdfs/2013_peer_review.pdf.

than 1 dry ton of feedstock per day. A pilot facility integrates key recycle streams to validate the process and techno-economic model, but is not intended to produce cost-competitive fuels due to its small scale of operations. Any problems identified in the pilot stage must be corrected prior to further scale-up, or it is unlikely that the next plant will achieve its design capacity, operability factor, and profitability.⁶⁴ Integrated pilot testing also generates the performance data and equipment specifications required to design a demonstration-scale facility, as well as to determine process sustainability metrics such as water use and greenhouse gas emissions. Successful integrated pilots strengthen projects at larger scales and encourage private investment.

Demonstration-scale facilities verify performance at a scale sufficient to provide data and equipment specifications required to design a pioneer-scale facility. Demonstration facilities, typically between one-fiftieth and one-tenth of the pioneer scale, prove all recycle streams and heat integration for more than 1,000 hours of operations. This length of testing validates process robustness across the variability of biomass feedstock and operating conditions while still meeting the product specifications. Demonstration-scale operational data is used to validate commercial equipment specifications and design factors for the pioneer facility. This data is used to balance sustainability performance across economic, social, and environmental dimensions, such as balancing the feedstock availability with site infrastructure and workforce requirements, or balancing emissions through heat integration or wastewater treatment. Demonstration-scale projects are not meant to produce positive cash flow, but instead to identify process design improvements and develop more precise cost estimates for the pioneer plant. In some cases, 1,000 hours of continuous operational data is sufficient to allow for a performance guarantee on the pioneer facility from a major EPC firm. An EPC performance guarantee is an important step in obtaining commercial financing for larger-scale facilities. To determine if a project is ready for demonstration scale, integrated pilot testing of all critical process steps must have been successfully completed.

Pioneer-scale, or “first-of-a-kind,” facilities prove economical production at commercial volumes on a continuous basis with a reliable feedstock supply and production distribution system and verify environmental and social sustainability performance. These facilities have a higher capital cost than subsequent plants, which reflects the uncertainty and flexibility required in a first-of-a-kind process. Future plants benefit from refinements due to pioneer operations. Successful design, construction, and operation of a pioneer facility are greatly dependent on prior development of integrated pilot- and demonstration-scale facilities that have generated the necessary performance data and equipment specifications. Once the pioneer facility achieves operation at full design capacity and reaches positive cash flow, the technology application can be replicated through commercial debt or project financing.

Figure 2-30 depicts the progression of a conversion technology from pilot to demonstration to pioneer plant. The concentric ovals indicate that each stage is inclusive of the prior stage and builds upon its results, while the table below it describes the unique objectives at each stage.

⁶⁴ Marton, A. (2011). “Research Spotlight: Getting off on the Right Foot – Innovative Projects.” Independent Project Analysis Newsletter, 3(1).

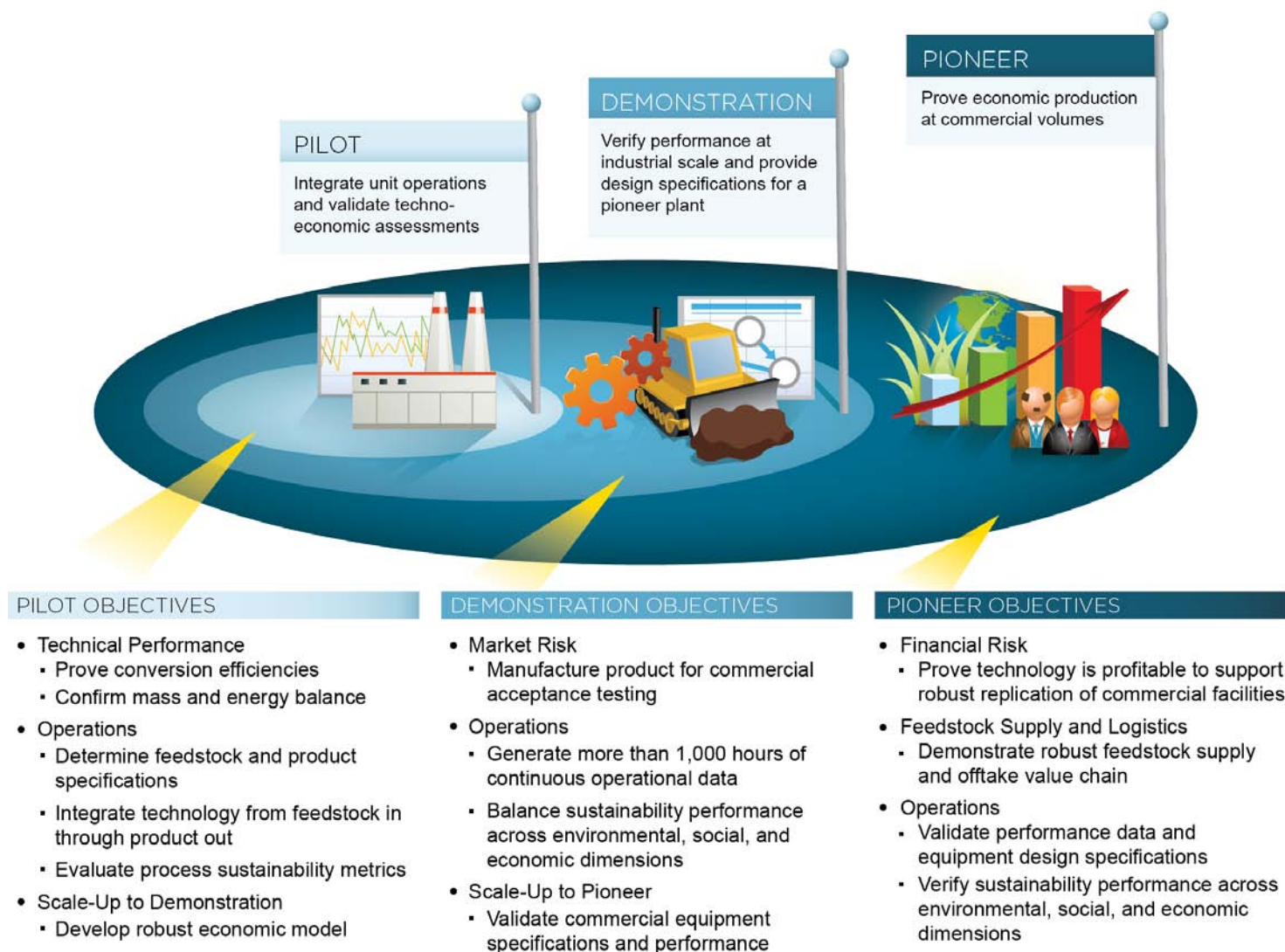

Figure 2-30: Description of key objectives at each integrated biorefinery scale

Infrastructure and End Use

Once biofuel, bioproduct, or biopower is produced, a number of distribution challenges remain for full market deployment. Biofuel use is constrained in some cases by fuel blending limits, integration with refinery process units, or existing pipelines and storage tanks infrastructure. In addition, infrastructure-compatible hydrocarbon biofuels require extensive certification testing, especially for the jet fuel market. Market acceptance of renewable home heating oil faces similar challenges and constraints, including blending limits and compatibility with home furnaces and transport and storage equipment. Bioproducts, whether used to replace fossil-based products or in a completely new market, will need to consistently meet the associated specifications. In addition, any biopower generated at a biorefinery may require capacity upgrades or reliability improvements to the local electricity grid.

Demonstration and Deployment Interfaces

The Office's R&D areas are focused on developing the scientific and engineering underpinnings of a bioenergy industry by understanding technical barriers and providing process and engineering solutions. The D&D projects then build upon these R&D efforts and create a feedback loop that uncovers additional barriers to commercial success at larger scale. The data and lessons learned from both R&D and D&D efforts are then used jointly for overall Office strategic planning.

Feedstock Research and Development

Successful commercialization of bioenergy technologies relies on a feedstock supply chain that can cost-effectively supply adequate volumes of a specified quality of feedstock to the biorefinery. Plant operations are dependent on a continuous, consistent feedstock supply of known quality attributes to achieve their performance targets. Feedstock cost, availability, variability, quality control, and storage are all parameters that greatly affect the performance of a facility. In addition to economic and technical parameters, feedstock handling and storage facilities must meet existing construction, safety, and fire codes that were not typically written for large-scale lignocellulosic biomass operations. Updating these codes to address the unique characteristics of biorefinery feedstock materials will require ongoing feedstock R&D to determine relevant material properties and optimal design standards.

Conversion Research and Development

Continued R&D to improve the conversion of biomass to biofuel, bioproducts, and biopower is necessary to increase conversion efficiency and lower costs. These efforts reduce the technological risk of the process and increase the probability of commercial success. Several existing D&D projects have been directly supported, and most have indirectly benefitted from the Office's past and current conversion R&D efforts.

2.3.1 Demonstration and Deployment Support of Office Strategic Goals

The strategic goal of the D&D Technology Area is to *develop commercially viable biomass utilization technologies through public-private partnerships that build and validate pilot-, demonstration-, and pioneer-scale integrated biorefineries; and to develop supporting infrastructure to enable a fully operational and sustainable biomass-to-bioenergy value chain in the United States.*

The biorefinery and infrastructure projects are testing advanced biofuels, bioproducts, and biopower from high-impact feedstocks, including herbaceous, woody, and algal feedstocks, as well as from MSW. D&D focuses on reducing risk to the consumer and the private sector and helping overcome challenges to financing the follow-on expansion of the industry, which is required to make a major contribution to our nation's energy independence.

2.3.2 Demonstration and Deployment Support of Office Performance Goals

Specific D&D goals in support of Office performance goals are as follows:

- By 2014, validate three cellulosic ethanol or bioproduct manufacturing processes at pioneer scale
- By 2017, validate a mature technology modeled cost of cellulosic ethanol production, based on actual IBR performance data, and compare to the target of \$2.15/gallon ethanol (\$2007)
- By 2027, validate a mature technology modeled cost of infrastructure-compatible hydrocarbon biofuel production, based on actual IBR performance data, and compare to the target of \$3/GGE (\$2011).

D&D milestones toward reaching these goals include the following:

- By 2018, validate three infrastructure-compatible hydrocarbon biofuel or bioproduct manufacturing processes at pilot scale
- By 2020, validate one to two infrastructure-compatible hydrocarbon biofuel or bioproduct manufacturing processes at demonstration scale
- By 2024, validate one infrastructure-compatible hydrocarbon biofuel or bioproduct manufacturing process at appropriate scale.

The objective of validating these technologies is to prove techno-economic viability and enable commercial production facilities. The 2014 goal reflects the validation efforts of the existing pioneer cellulosic ethanol facilities in the D&D portfolio; the 2018 and beyond goals reflect the focus on infrastructure-compatible hydrocarbon biofuels. Table 2-12 contains the projects expected to contribute to the 2014 performance goal.

Table 2-12: Estimated Project Contribution for 2014 Performance Goal

Project	Production Capacity million gallons	Fuel	Conversion Route	Feedstock
Abengoa	25	Cellulosic Ethanol	Biochemical	Agricultural Residue
Poet	25	Cellulosic Ethanol	Biochemical	Agricultural Residue
INEOS New Planet Bioenergy	8	Cellulosic Ethanol	Thermochemical/ Biochemical Hybrid	Green Waste and MSW

Historically, D&D performance goals were focused on validation of production capacity in a given year. Because the capacity of a pioneer project can be more than 100 times the capacity of a pilot project, these capacity goals relied on a disproportionately small number of pioneer projects. These pioneer projects face significant barriers outside the control of the D&D Technology Area, such as securing financing or long delays in construction and start-up. Also, the efforts to validate technology and reduce risk at pilot and demonstration scale were not reflected. Therefore, future performance goals and milestones will focus on validating a specific number of technologies at various scales instead of a projection of production capacity.

2.3.3 Demonstration and Deployment Challenges and Barriers

Market Challenges and Barriers

Im-A. Inadequate Supply Chain Infrastructure: Feedstock variability and lack of feedstock infrastructure increases the uncertainty associated with a sustainable feedstock supply chain. Variable composition, geographical diversity, and diverse physical characteristics (such as particle size) impact supply chain costs. Producing and delivering a feedstock that meets the conversion specifications and cost targets of the biorefinery in sufficient volumes to support a commercial, advanced biofuels industry will require incentive programs to stimulate the large capital investments needed for feedstock production, preprocessing, storage, and transport to commodity markets. Feedstock infrastructure, such as handling and storage facilities, also must meet existing construction, safety, and fire codes, which, in most cases, were not written for large-scale lignocellulosic biomass operations.

Im-B. Agricultural Sector-Wide Paradigm Shift: Energy production from biomass on a scale sufficient to meet the Energy Independence and Security Act of 2007 Renewable Fuel Standard goals, or those of a future Renewable Portfolio Standard, will require a series of major system changes that will take time to implement. Current terrestrial feedstock logistics systems are designed for high-yielding areas. These logistics systems are inadequate for processing and distributing biomass on the scale needed to support dramatically larger volumes of biofuels production and do not address all of the quality specifications.

Im-C. High Risk of Large Capital Investments: Once emerging biomass technologies have been developed and tested, they must be commercially deployed. Financial barriers are the most challenging aspect of technology deployment. Capital costs for commercially viable facilities are relatively high, and securing capital for an unproven technology is extremely difficult. Lenders are hesitant to provide debt financing for first-of-a-kind facilities where the process performance

cannot be adequately guaranteed. Government assistance to validate proof of performance at the pilot, demonstration, and pioneer scales is critical to successful deployment. Another significant challenge for debt financing of first-of-a-kind commercial facilities is the lack of long-term, consistent federal policies. Lenders will not consider federal incentives and subsidies as income in the consideration of loan applications if it is perceived that federal (and state) policies and financial support mechanisms are uncertain.

Im-D. Lack of Industry Standards and Regulations: The lack of local, state, and federal regulations, as well as inconsistency among existing regulations, constrains development of the biomass industry. The long lead times associated with developing and understanding new and revised regulations for technology can delay or stifle commercialization and full market deployment. Consistent standards and sampling methods are lacking for feedstock supply and infrastructure, as well as for biofuel and other bioproducts, including home heating oil and the associated distribution infrastructure.

Im-E. Cost of Production: An overarching market barrier for biomass technologies is the inability to compete, in most applications, with established fossil energy supplies and supporting facilities and infrastructure. Previous analysis has shown that doubling of cumulative industrial capacity leads to an average reduction of 75% in cost⁶⁵ for process technologies. The accelerated industrial learning that occurs during this capacity growth also has been successful in reducing cost in the fuels and chemicals industry over the past several decades.⁶⁶ Reductions in production costs along the entire biomass supply chain—including feedstock supply, conversion processes, and product distribution—are needed to make advanced biofuels, bioproducts, and biopower competitive with petroleum-derived analogs.

Im-F. Offtake Agreements: Production costs, and therefore selling price and profits, of commodity fuels and chemicals derived from crude oil are dependent on a fluctuating market. Generally, these companies offer products on a contract basis; however, they often sell to the market on the spot to generate the greatest return on investment. Offtake agreements can often take the form of fixed-price contracts for 1–2 years, followed by contracts fixed to a specific index (such as the Chicago Board of Trade pricing). The producer then must adjust its *pro forma* accounting and variable cost structure to account for such market fluctuations. Another challenge with fuel offtake agreements is that the industry standard is 1–2 years, in contrast to the term of debt financing, which can range from 7–15 years or longer. The providers of long-term debt generally require the duration of the offtake agreement to match the length of the loan, which is a difficult challenge when the product selling price is dependent on a fluctuating market.

Im-G. Uncertain Pace of Biofuel Availability: There is uncertainty regarding the pace of development and commercialization of new biofuel technology. Additionally, there is uncertainty surrounding which types of biofuels will be produced and at what volumes over the

⁶⁵ Merrow, E.W. (1989). “An Analysis of Cost Improvement in Chemical Process Technologies,” RAND R-3357-DOE.

⁶⁶ Gummerman, E., Marnay, C. (2004). “Learning and Cost Reductions for Generating Technologies in the National Energy Modeling System (NEMS).” LBNL-52559. Ernest Orlando Lawrence Berkeley National Laboratory, University of California Berkeley.

short and long term, adding risk to investment in biofuels infrastructure. Other factors, such as the price of oil, the pace of economic recovery, climate legislation, and other policy measures, also complicate investment decisions.

Im-H: Availability of Biofuels Distribution Infrastructure: The infrastructure required to distribute and dispense large volumes of ethanol does not currently exist, which puts this biofuel at a disadvantage compared to conventional liquid transportation fuels that already have mature infrastructure. Ethanol is currently transported predominantly by rail and truck. Without large capital investments, these transport modes are expected to encounter significant congestion issues over the coming decades, especially in the Midwest. Higher-level ethanol blends, such as E85 (and other less compatible biofuels), require separate storage tanks and dispensers, and may require other material modifications at refuels stations. Most refueling stations are privately owned with relatively thin profit margins, and owners have been reluctant to invest in new infrastructure until the market is more fully developed. Further, some refueling stations may not have enough space available to add dispensers and new storage tanks. The scarcity of E85 refueling stations makes it difficult for consumers who own FFVs to use E85 and also makes it less likely that potential new consumers will purchase an FFV. Petroleum-compatible biofuels may also require distribution infrastructure investment including east-west pipeline expansion.

Im-I. Lack of Acceptance and Awareness of Biofuels as a Viable Alternative: To be successful in the marketplace, biomass-derived fuels and chemical products must perform as well or better than comparable petroleum- and fossil-based products. Industry partners and consumers must believe in the quality, value, sustainability, and safety of biomass-derived products and their benefits relative to the risks and uncertainties that widespread changes will likely bring. Compared to other renewable technologies, consumer acceptance and awareness of biofuels and bioenergy technologies are varied. Impartial, reliable information regarding the economic and environmental benefits and impacts of increased bioenergy use is not always widely available.

Technical Challenges/Barriers

It-A. End-to-End Process Integration: Successful deployment of the biorefinery business model is dependent on advances in integrated conversion process technologies. The biorefinery concept encompasses a wide range of technical issues related to collecting, storing, transporting, and processing diverse feedstocks, as well as the complexity of integrating new and unproven process steps. The demonstration and validation of total process integration—from feedstock production to end-product distribution—is crucial, as it impacts both performance and profitability.

It-B. Risk of First-of-a-Kind Technology: Pioneer biorefineries will incorporate a variety of new technologies. The number and complexity of new process steps implemented in pilot- and demonstration-scale projects have been shown to be a strong predictor of future commercial performance shortfalls. Heat and mass balances, along with the implications, are not likely to be well-understood in new technologies. In addition, start-up and commissioning the equipment may take longer than expected due to issues that were not observed at smaller scales, including

buildup of impurities in process recycle streams, degradation of chemical or catalyst performance and abrasion, fouling, and corrosion of plant equipment.

It-C. Technical Risk of Scaling and Fully Integrating Biomass Conversion Technologies:

Commercially viable biofuel production requires large scale, complex, capital intensive biorefinery process technologies. Unit operations proven at small scale under laboratory conditions need to be scaled up and integrated at pilot scale to validate process performance. Given the magnitude of capital investment required, scaling from pilot to full commercial scale, as much as a 500-1000X increase in scale, involves a level of technical risk which few investors are willing to assume. Best practices from other process industries suggest more modest scaling factors of 50X from pilot to demonstration scale and of 10-20X from demonstration to first-of-a-kind pioneer scale⁶⁷. This step-wise scaling enables full integration of unit operations, more complete validation and optimization of process operations and development of equipment specifications which may enable process performance guarantees.

It-D. Engineering Modeling Tools: The current level of understanding regarding fuels chemistry is insufficient for optimization, scale-up, and commercialization. To better understand how fuel chemistry affects commercial viability, rigorous computational fluid dynamic models are needed. Engineering modeling tools are also needed to address heat integration issues.

It-E. Codes, Standards, and Approval for Use: New biofuels and biofuel blends must comply with federal, state, and regional regulations before introduction to the market. The EPA plays a central role in approving new fuels for use. Technical codes and standards are developed by organizations, including the American Society for Testing and Materials International and Underwriters Laboratory. Safety, health, and environmental standards are developed by the Occupational Safety and Health Administration, the U.S. Department of Homeland Security, and others. Codes and standards are adopted by state and local jurisdictions to ensure product safety and reliability and reduce liability. Limited data and technical information can also delay approvals of technical codes and standards for biofuels and related infrastructure components, including pipelines, storage tanks, and dispensers.

It-F. Engines Not Optimized for Biofuel: Transportation vehicle manufacturers are under pressure to design vehicles with lighter weight and higher overall fuel efficiency to meet the Corporate Average Fuel Economy (CAFE) standards at the same time as biofuels and biofuel blends enter the market place. In current motor vehicle engines, some biofuels result in decreased fuel economy on a miles per gallon basis, relative to petroleum fuels. For instance, ethanol has a lower energy density than gasoline, approximately 76,000 British thermal units (Btu) per gallon of ethanol in comparison to 115,000 Btu per gallon of gasoline,⁶⁸ but it also has a higher octane rating of 115 compared to 85–88 for regular gasoline. The actual fuel economy impact is dependent on a variety of factors, but the negative effects may be mitigated through optimizing engines for higher octane fuel with higher renewable content.

⁶⁷ Peters, Max S.; Timmerhaus, Klaus D.; West, Ronald E., *Plant Design and Economics for Chemical Engineers*, 2003.

⁶⁸ U.S. Department of Energy. (2007). “Annual Energy Outlook 2007: Biofuels in the U.S. Transportation Sector, Table 11.” Washington, D.C.: Government Printing Office, <http://www.eia.doe.gov/oiaf/analysispaper/biomass.html>.

2.3.4 Demonstration and Deployment Approach for Overcoming Challenges and Barriers

The approach for overcoming D&D challenges and barriers includes both how efforts and projects are organized within their WBS, as well as the specific framework used to manage high-profile, large, capital-intensive demonstration projects.

The D&D WBS is outlined in Figure 2-31 and in Table 2-13 below. The current activities generally fall into five categories: Analysis and Sustainability, Technology Interface, Feedstocks, Integrated Biorefineries, and Infrastructure and End Use. D&D activities are primarily performed by industry partners, with national laboratories and universities also making significant contributions.

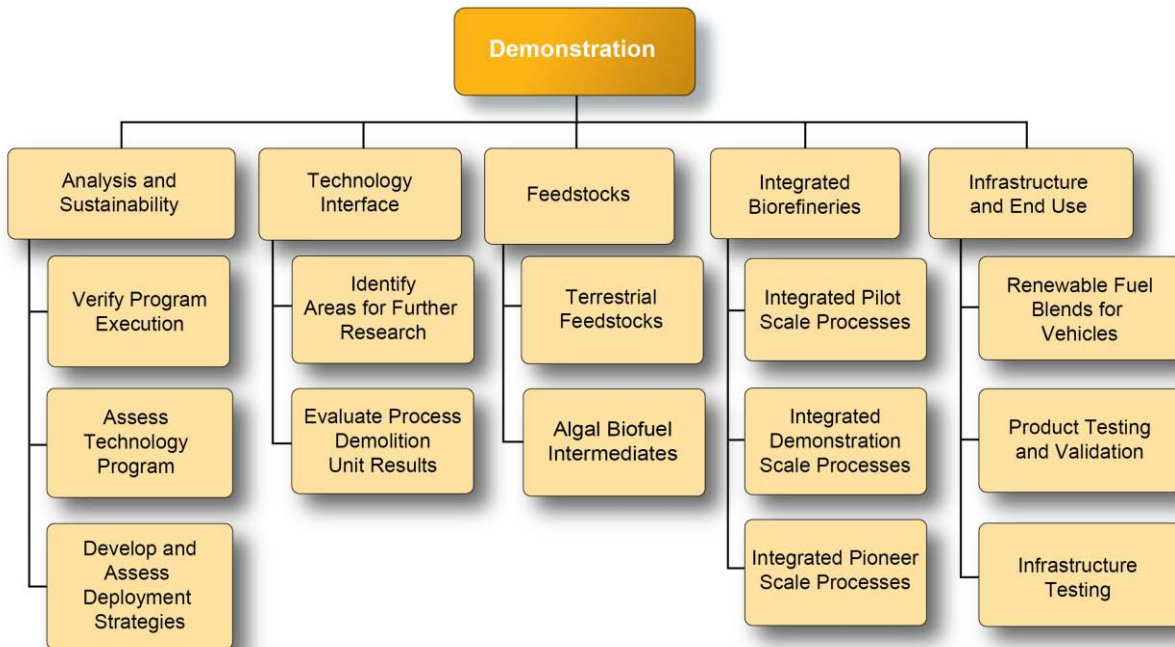

Figure 2-31: Demonstration and Deployment work breakdown structure

Analysis and Sustainability

Both project-specific and portfolio-wide evaluations assess progress toward objectives and sharpen the focus of D&D strategies on the areas with the highest potential impact to the bioindustry. These evaluations, which encompass a broad range of technical performance and economic, social, and environmental sustainability metrics, are updated annually to reflect developments within each project and the industry. Specific metrics include process performance by unit operation; financial data, including pro forma and actual capital and operating costs; and sustainability metrics, including water usage, lifecycle greenhouse gas emissions, and jobs created. This data is used to monitor progress against goals, assess the current SOT for various biomass utilization technologies, and determine the projected commercial impact of various projects.

Technology Interface

D&D projects integrate broad sets of technologies from the Feedstock Supply and Logistics and Conversion R&D Technology Areas. Technology interface activities help identify (1) when technologies are ready for piloting and scale-up, (2) entirely new feedstock logistics systems or conversion technologies, or (3) improvements to a smaller set of unit operations. In addition, new challenges discovered during scale-up are shared in a feedback loop with R&D areas.

Feedstocks

Every IBR starts with feedstock as an input, and efforts to improve the supply and logistics system are essential for commercial operations. These activities span both terrestrial feedstock systems and the production of algal biofuel intermediates to identify areas for improvement in conventional feedstock supply and logistics systems and in the development of advanced feedstock logistics systems.

Integrated Biorefineries

Validating performance at integrated pilot, demonstration, and pioneer scales is essential to de-risk technology and enable financing that will catalyze the transition to large-scale renewable fuel production. Operation at each of these scales systematically addresses many of the market and technical barriers previously identified. Integrated pilots prove the end-to-end process and develop engineering modeling tools. Demonstration-scale facilities then allow for more optimized equipment specifications and can manufacture product for commercial acceptance that can lead to offtake agreements for the pioneer plant. Finally, pioneer plants prove continuous economic operation with large-scale supply chains. Operational data at each scale is also used to address many other barriers, including sustainability.

The success of IBR projects is expected to provide assurances that offtake agreements for biofuels, bioproducts, and biopower can be managed for future commercial financing. Analogous to the petrochemical industry's development of refinery infrastructure, biorefinery projects showing success should translate into better financing potential.

Infrastructure and End Use

In addition to the significant risks involved with scale-up of new technology, other market barriers related to infrastructure and end use also limit the amount of advanced biofuel production. Efforts in this area are focused on enabling higher rates of renewable fuel usage in current markets while addressing barriers for expansion into new markets, such as home heating oil. This includes working closely with DOE's Vehicle Technologies Office to develop and deploy alternative vehicle and fuel technologies through its Clean Cities Program and other avenues.

Table 2-13: D&D Activity Summary

WBS Element	Description	Barrier(s) Addressed
Analysis and Sustainability	<p>Verify progress of projects toward objectives, assess development of overall technologies across the "Valley of Death," and develop strategies to focus on the most promising areas.</p> <ul style="list-style-type: none"> - Verification of technology deployment, including Independent Engineer evaluations of each project. - Assess progress of biorefineries through TEA. - Deploy models and planning processes to assess the impact of D&D projects on overall bioindustry development. 	<p>Im-A: Inadequate Supply Chain Infrastructure Im-B: Agricultural Sector-Wide Paradigm Shift Im-D: Lack of Industry Standards and Regulations It-B: Risk of First-of-a-Kind Technology It-D: Engineering Modeling Tools St-C: Sustainability Data across Supply Chain St-D: Implementing Science-Based Indicators and Methodology for Evaluating and Improving Sustainability St-F: Systems Approach to Bioenergy Sustainability</p>
Technology Interface	<p>Maintain a R&D feedback loop on new technologies ready for piloting and in identifying additional barriers and research needs at larger scale.</p> <ul style="list-style-type: none"> - Monitor progress of emerging technologies within R&D areas, incubators, and outside sources. - Identify additional barriers and research needs at larger scale through biorefinery projects. 	<p>Ft-D: Sustainable Harvesting Mm-A: Lack of Understanding of Environmental/Energy Tradeoffs It-A: End-to-End Process Integration</p>
Feedstocks	<p>Deploy technologies to provide a secure, reliable, affordable, high-quality, and sustainable cellulosic and algal biomass feedstock supply for the U.S. bioenergy industry.</p> <ul style="list-style-type: none"> - Demonstrate pioneer-scale terrestrial feedstock supply systems. - Demonstrate algal feedstock supply systems to validate technology performance. 	<p>Ft-A: Terrestrial Feedstock Availability and Cost Ft-E: Terrestrial Feedstock Quality and Monitoring Im-A: Inadequate Supply Chain Infrastructure Im-B: Agricultural Sector-Wide Paradigm Shift Im-E: Cost of Production It-A: End-to-End Process Integration It-B: Risk of First-of-a-Kind Technology It-D: Engineering Modeling Tools</p>
Integrated Biorefineries	<p>Demonstrate and validate IBR technologies at pilot, demo, and pioneer scale.</p> <ul style="list-style-type: none"> - Pilots integrate unit operations from feedstock-in through product-out at ≥ 1 dry tonne per day. - Demonstrations prove all recycle streams and heat integration and develop equipment specifications for larger-scale facilities. - Pioneers, or first-of-a-kind plants, prove economical production at commercial volumes on a continuous basis along with a reliable feedstock supply and production distribution system. 	<p>Ft-E: Terrestrial Feedstock Quality and Monitoring Ft-F: Biomass Storage Systems Im-A: Inadequate Supply Chain Infrastructure Im-B: Agricultural Sector-Wide Paradigm Shift Im-C: High Risk of Large Capital Investments Im-D: Lack of Industry Standards and Regulations Im-E: Cost of Production Im-F: Offtake Agreements It-A: End-to-End Process Integration It-B: Risk of First-of-a-Kind Technology It-C: Technical Risk of Scaling and Fully Integrating Biomass Conversion Technologies It-D: Engineering Modeling Tools</p>
Infrastructure and End Use	<p>Enable higher rates of renewable fuel usage and define the needs for biofuels infrastructure and market use through 2030.</p> <ul style="list-style-type: none"> - Address barriers to renewable fuel use in new, existing, and future automobile engines and other areas, such as replacing home heating oil. 	<p>Im-D: Lack of Industry Standards and Regulations Im-G: Uncertain Pace of Biofuel Availability Im:H Availability of Biofuels Distribution Infrastructure Im-I: Lack of Acceptance and Awareness of Biofuels as a Viable Alternative It-E: Codes, Standards, and Approval for Use It-F: Engines Not Optimized for Biofuel</p>

Integrated Biorefinery Project Management Framework

The D&D team established a project management framework with additional project management, verification, and oversight procedures to effectively manage the large-scale, capital-intensive IBR activities. The project management framework incorporates DOE standards for management of capital assets, the Office’s priorities, and best practices from industry, including use of an Independent Engineer (IE). The framework, shown in Figure 2-32, is divided into four main sections that correlate contractual Budget Periods (BP) to the Critical Decision (CD) Points identified in DOE Order 413.3B.⁶⁹

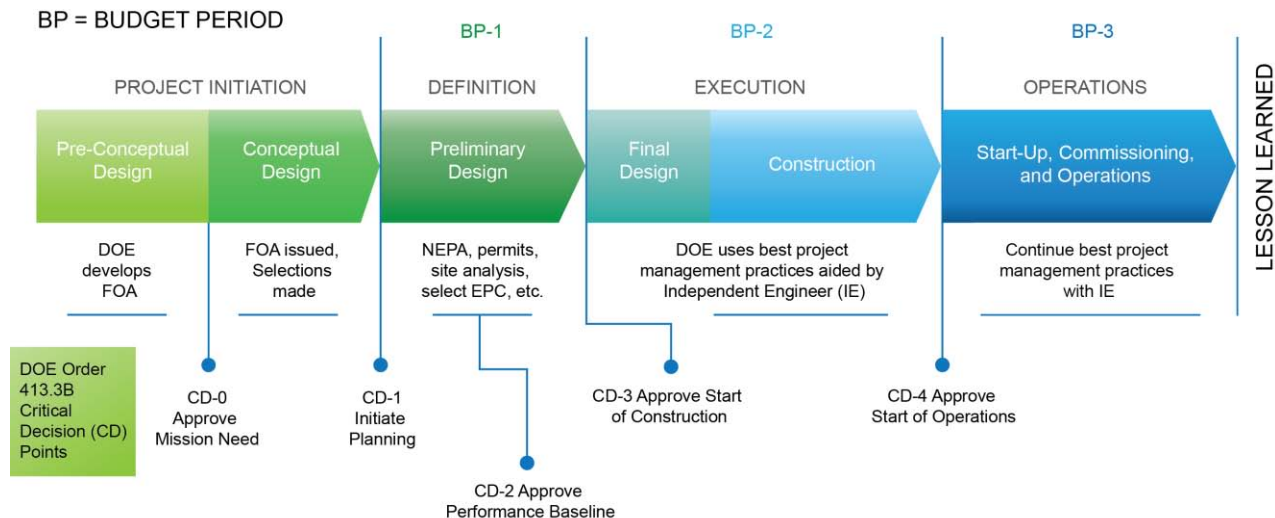

Figure 2-32: Framework for executing DOE project management for integrated biorefinery projects

Critical Decision Points

CD-0 is an internal DOE activity to appropriate funds, determine the nature of a funding opportunity announcement, and execute the competitive selection process. CD-0 effectively ends once the selections are made.

CD-1 begins with the award negotiation and continues with approval of the performance baseline for project scope, schedule, cost, and risk analysis. This corresponds to stage 1 in Front-End Loading (FEL-1) project management practices.

CD-2 occurs when the Project Management Plan (PMP) is put under DOE change control⁶⁹ and the project locks down its performance baseline. The PMP forms the more detailed basis for the project scope (Statement of Project Objectives) that becomes the contractual basis for the obligation of BP-1 funds to the award. CD-2 also corresponds to an FEL-2 with a -15%/+ 30% cost estimate accuracy for EPC.

⁶⁹ U.S. Department of Energy. DOE Order 413.3B, Program and Project Management for the Acquisition of Capital Assets, <https://www.directives.doe.gov/directives-documents/0413.3-BOrder-b/view>.

CD-3 requires completing the project financing, submitting the design for bids to EPC contractors, and meeting -5%/+15% cost estimate accuracy (FEL-3). Approval of CD-3 releases the federal funds for BP-2, which typically has the highest associated cost of the three budget periods because of the procurement and construction components.

CD-4 is executed when the project has demonstrated readiness to begin operations. For demonstration and pioneer plants, CD-4 is based on meeting design performance objectives and usually occurs after the performance test has been completed. For some pilot plants, the performance test is what sets the baseline performance targets, so CD-4 is sometimes authorized as part of BP-2 during the start-up/commissioning of the plant.

Independent Engineer Role

The Office retains the services of an IE to assess an awardee's capabilities to successfully execute major capital projects and identify the risks associated with each IBR project. The IE's external independent reviews provide detailed analysis of the technical, organizational, financial, engineering, environmental, economic, and project-related risks at each CD point. The IEs monitor the IBR projects throughout all phases, are called upon to perform independent validation of technical stage gates, and complete formal IBR performance tests. Using an IE firm to perform due diligence reviews is a best practice in many industries, including bioenergy, and a major component of investment decisions by private equity, venture capital firms, and commercial banks.

2.3.5 Prioritizing Demonstration and Deployment Barriers

All of the primary barriers faced in the D&D area must be successfully addressed to produce high volumes of advanced biofuels, bioproducts, and biopower. The following areas are critical and will be emphasized in D&D efforts:

- Validation of proof of performance at integrated pilot, demonstration, and pioneer scales
- Reduction of biorefinery capital and operating costs
- Product qualification testing and offtake agreements.

Financial barriers are the most challenging aspect of technology deployment. Capital costs for commercially viable facilities are relatively high, and securing capital for an unproven technology is extremely difficult. Lenders typically will not provide debt financing for pioneer facilities where the process performance cannot be adequately guaranteed. The D&D Technology Area is uniquely positioned to leverage both legislative authority for financial assistance and DOE's successful track record in commercialization to assist developers in de-risking technologies through validated proof of performance at the pilot, demonstration, and pioneer scales. This assistance is critical to enable equity holder and lender confidence to invest in facility construction and replication at the commercial scale.

Demonstration projects that use federal cost-share funding have shown greater success when the basic technology principles were already proven at smaller scales.⁷⁰ In addition, the use of a pilot

⁷⁰ Baer, W.S., et al. (1976). "Analysis of Federally Funded Demonstration Projects: Executive Summary." RAND R-1925-DOC, <http://www.rand.org/content/dam/rand/pubs/reports/2006/R1925.pdf>.

plant led to an increase of almost 50% in the average actual rate of production and a reduction of almost 30% in the start-up duration for a pioneer project—based on a database of more than 1,000 similarly innovative projects.⁷¹ 64 D&D supports commercialization in the bioprocessing industry through developing a portfolio of a larger number of integrated pilots, a smaller number of demonstrations, and an even smaller number of pioneer-scale plants.

Prioritizing the efforts of the D&D team requires extensive stakeholder input from industry; national laboratories; academia; and other government agencies, such as USDA and the U.S. Department of Defense. Estimating effects of these efforts requires consistent assumptions across a range of market variables, including—but not limited to—national biomass cost and supply curves; biomass logistics systems; projected demand for biofuel, bioproducts, and biopower; learning rates of various conversion technology pathways; and government and tax policies; in addition to any correlation these variables have with each other. The National Renewable Energy Laboratory’s Biomass Scenario Model⁷² was utilized to provide consistent assumptions across various D&D scenarios and gain insight into selecting priorities.⁷³

Figure 2-33 shows the estimated effect of prior Office activities as a projection of the number of biorefineries enabled through 2030. The baseline includes the state of the industry and the existing D&D project portfolio. The graph on the right shows the potential impact of expanding the D&D portfolio to meet 2018–2024 D&D milestones. The figure illustrates how D&D efforts are projected to enable a substantial increase in the number of biorefineries by 2030.

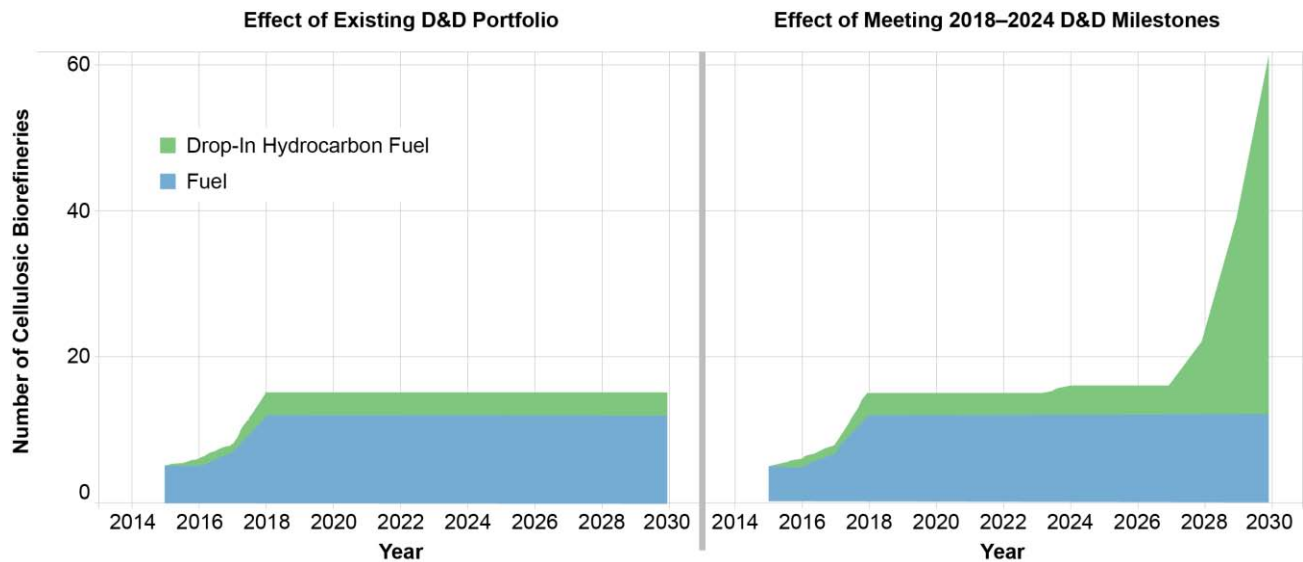

Figure 2-33: Biomass scenario model projection of the number of cellulosic biorefineries enabled by the Office’s D&D efforts

⁷¹ Marton, A. (2011). “Research Spotlight: Getting off on the Right Foot – Innovative Projects.” Independent Project Analysis Newsletter, 3(1).

⁷² The Biomass Scenario Model is further described in Section 2.5 under Strategic Analysis.

⁷³ Vimmerstedt, L. J., Bush, B. W. (2013). “Effects of Deployment Investment on the Growth of the Biofuels Industry.” NREL/TP-6A20-60802. Golden, CO: National Renewable Energy Laboratory, <http://www.nrel.gov/docs/fy14osti/60802.pdf>.

2.3.6 Demonstration and Deployment Milestones and Decision Points

The key D&D milestones and decision points to complete the tasks described in Section 2.3.4 are summarized in Figure 2-34. The validation of integrated conversion technologies includes tracking and reporting the demonstrated performance metrics for each project. Milestones and go/no-go decisions are used to evaluate the progression of each biorefinery award at several stage gates, including the baseline of results achieved prior to award and through project initiation, construction, start-up, and operations.

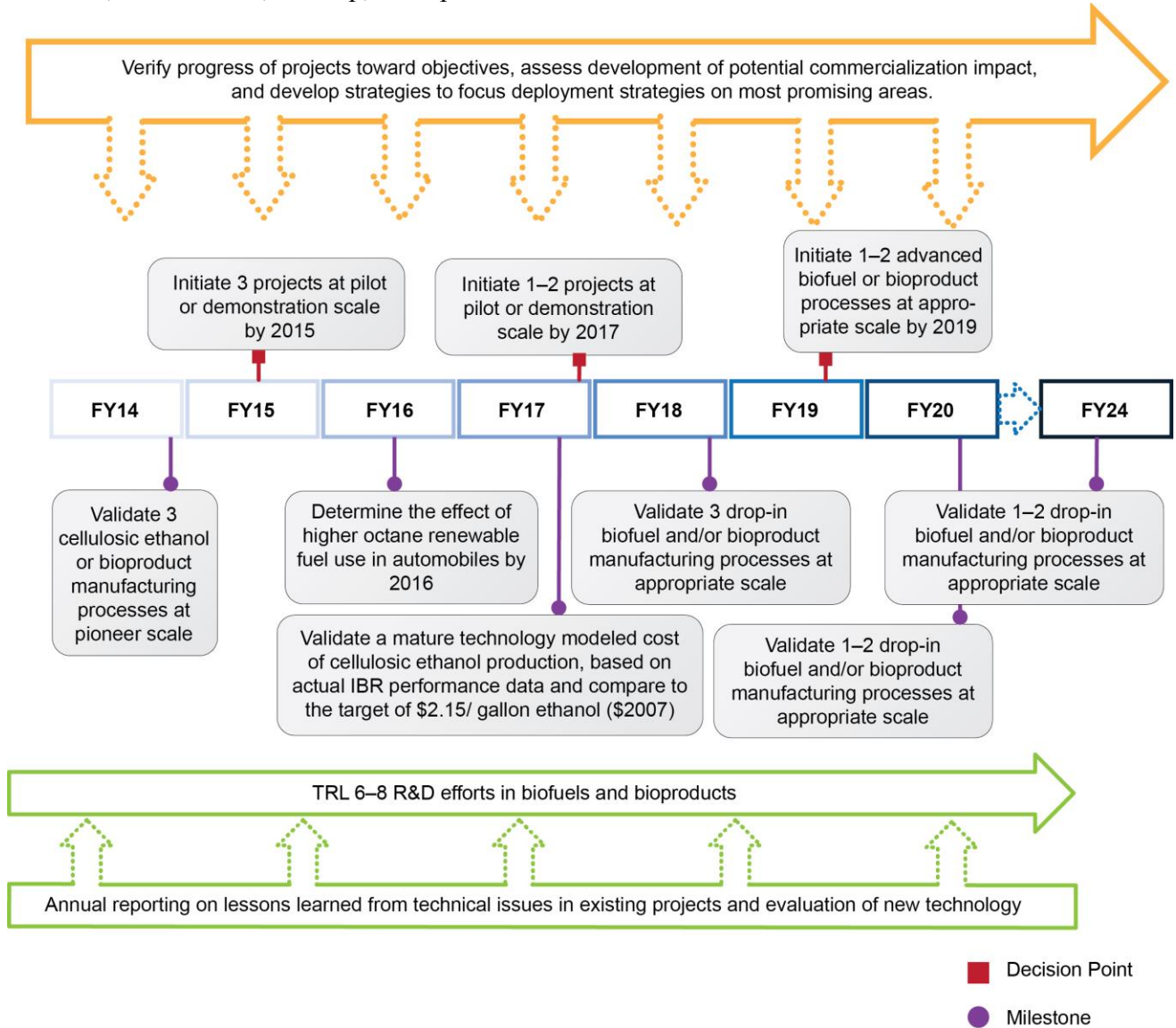

Figure 2-34: Demonstration and deployment key milestones and decision points

2.4 Sustainability

The Bioenergy Technologies Office is committed to developing the resources, technologies, and systems needed to grow a bioenergy industry in a manner that protects natural resources and maximizes economic, social, and environmental benefits. The Office’s Sustainability Technology Area proactively identifies and addresses issues that affect the scale-up potential, public acceptance, and long-term viability of advanced bioenergy systems; as a result, the area is critical to achieving the Office’s overall goals. The existing and emerging biofuels industry will need to develop systems that are not just based on economic viability and market needs, but also on environmental and social aspects such as resource availability and public acceptance. To that end, the Sustainability Technology Area supports analysis, research, and collaborative partnerships to develop and promote practices and technologies that maximize the benefits of bioenergy production activities while mitigating concerns. Sustainability is not an end state or specific goal; rather, the Office is committed to continuous improvement across multiple environmental, economic, and social objectives. The Office collaborates with other government agencies and diverse stakeholders from industry, nongovernmental organizations, research institutions, and international bodies to define those goals and priorities.

Executive Order 13514 (Federal Leadership in Environmental, Energy, and Economic Performance) provides the following definition for sustainability: “To create and maintain conditions, under which humans and nature can exist in productive harmony, that permit fulfilling the social, economic, and other requirements of present and future generations.” Based on this mandate, the Office’s sustainability efforts span environmental, social, and economic dimensions—the three core aspects of sustainability (see Figure 2-35). Maintaining the benefits and services provided by natural resources, promoting economic development, and providing conditions that support human and societal health are all critical components of a sustainable bioenergy industry.



Figure 2-35: Bioenergy Technologies Office sustainability scope

The Office works closely with other federal and international agencies whose missions incorporate bioenergy, such as USDA, EPA, and others. While several federal agencies play important roles along the bioenergy supply chain—such as biomass production within USDA and environmental impacts within EPA—the Office addresses the integration of multiple dimensions of sustainability across all supply chain components. This includes collaborating with relevant research and regulatory entities to enhance the benefits of emerging bioenergy technologies and feedstock varieties, as well as anticipating and mitigating unintended consequences.

The Office also is actively involved in international dialogues on sustainable bioenergy. In coordination with the U.S. State Department and USDA, the Office participates in the Global Bioenergy Partnership to contribute technical expertise and communicate the U.S. experience in evaluating and enhancing bioenergy sustainability. The Office also contributes technical expertise to sustainability efforts led by the International Energy Agency, the Intergovernmental Panel on Climate Change, and the International Organization for Standardization. These international engagements accelerate R&D on sustainable bioenergy production through mutually beneficial technical exchanges and sharing of research results. These collaborations also enable the Office to stay informed of international market developments that affect the U.S. bioenergy industry, as well as help ensure that the U.S. perspective and scientific contributions are represented.

Environmental, Economic, and Social Sustainability across the Bioenergy Supply Chain

Environmental, economic, and social implications are relevant across the full bioenergy supply chain (see Figure 2-36). Evaluating effects and promoting improvements in each sustainability category necessitates different measures and types of activities depending on the stage of the supply chain. For example, certain environmental categories—such as soil quality and biological diversity—are most relevant to biomass production, while others—such as water and air emissions—are monitored across most or all stages.

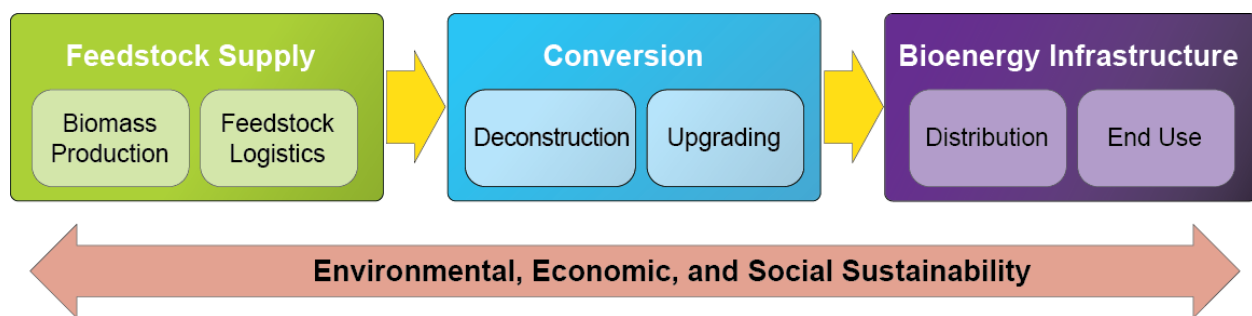

Figure 2-36: Sustainability across the bioenergy supply chain

Environmental Sustainability

Environmental categories of interest are based on the primary effects that many bioenergy systems have or are likely to have on environmental sustainability. These categories and the associated objectives are as follows:

- *Greenhouse Gas Emissions*: Reducing greenhouse gas emissions and climate impacts

- *Soil Quality*: Maintaining or improving soil quality
- *Water Quality and Quantity*: Maintaining or improving water quality, reducing water use, and improving water-use efficiency
- *Air Quality*: Minimizing air pollutants and maintaining or improving air quality
- *Biological Diversity*: Conserving plant and animal diversity and protecting habitat and ecological systems
- *Land Use and Productivity*: Enhancing beneficial land-use management and maintaining or improving land productivity.

Economic Sustainability

The primary goal of the Office is to promote a commercially viable bioenergy industry in the United States. Several economic sustainability categories are critical for measuring progress toward this goal. When assessing and documenting the SOT for promising bioenergy pathways, the primary measurements include return on investment, net present value, process efficiency, and yield of desired products. Economic sustainability is interwoven into the Office's strategic goals. The interaction between economic sustainability and the other two components (social and environmental) is also considered in depth.

Social Sustainability

Social sustainability is critical to ensure that development of the bioenergy industry aligns with societal values and promotes social goals. Social sustainability categories and the associated objectives are as follows:

- *Social Acceptability*: Improving public opinion through science-based information, minimizing risks, maximizing transparency, and ensuring effective stakeholder participation
- *Social Well-Being*: Maintaining or improving prosperity, safety, health, and food security
- *Energy Security and External Trade*: Reducing dependence on foreign oil, increasing access to affordable energy, demonstrating a positive net energy balance relative to fossil fuels, and improving the balance of trade between imports and exports for energy-related materials
- *Resource Conservation*: Minimizing use of non-renewable resources relative to renewable resources and enhancing the energy return on investment
- *Rural Development and Workforce Training*: Creating job opportunities, enhancing rural livelihoods, and developing a skilled bioenergy workforce.

System-Level Sustainability

System-level sustainability considers the relationship within and between the sustainability categories above. System-level sustainability, for example, could focus on optimizing a technology for both economic and environmental factors to find the most beneficial outcome.

2.4.1 Sustainability Support of Office Strategic Goals

Sustainability is an integral part of the Office's vision and strategic goal. The strategic goal of the Sustainability Technology Area is *to understand and promote the positive economic, social, and environmental effects and reduce the potential negative impacts of bioenergy production activities.*

The Sustainability Technology Area interfaces with and impacts all elements of the biomass-to-bioenergy supply chain and at each stage of the development of bioenergy. Considering sustainability early in technology development—rather than after systems are finalized and replicated—enhances the future economic and technical viability of those technologies. Sustainability activities closely align with the feedstock and technology pathways pursued under the Office's R&D and D&D areas. Additionally, the Sustainability Technology Area conducts integrative, cross-cutting, and systems-level activities to understand aggregate effects and identify opportunities for improvement at different scales and across multiple economic and socioeconomic parameters.

2.4.2 Sustainability Support of Office Performance Goals

The Sustainability Technology Area's goals and milestones will be met by evaluating bioenergy systems and demonstrating continuous improvements, or the potential for improvement, across multiple sustainability categories and bioenergy production systems. This includes the feedstocks, logistics systems, and conversion technologies pursued through the Office's R&D and D&D areas.

The overall performance goals for the Sustainability Technology Area are as follows:

- By 2014, quantify the water footprint of cellulosic feedstocks at the county level,⁷⁴ identify modeled feedstock production systems that increase energy crop production and agricultural residue removal by 50%, increase soil quality by at least 5%,⁷⁵ and improve water quality compared to traditional agricultural management
- By 2017, identify conditions under which at least one technology pathway for hydrocarbon biofuel production, validated above R&D scale at a mature modeled price of \$3/GGE, reduces greenhouse gas emissions by 50% or more compared to petroleum fuel, and meets targets for consumptive water use, wastewater, and air emissions⁷⁶
- By 2022, validate landscape design approaches for two bioenergy systems that, when compared to conventional agricultural and forestry production, increase land-use

⁷⁴ See the Water Analysis Tool for Energy Resources (WATER): <http://water.es.anl.gov/>. The water footprint accounts for the water demand, water consumption, and water pollutant loads associated with feedstock production and biorefinery processes.

⁷⁵ Represents a modeled 5% increase in soil organic carbon and soil erosion less than half of the T-value.

⁷⁶ Targets for water consumption will be based on potential process and plant design improvements. Targets for wastewater and air emissions will be based on water quality standards, pollutant discharge regulations, and federal air quality regulations.

efficiency and maintain ecosystem and social benefits, including biodiversity and food, feed, and fiber production⁷⁷

- By 2022, evaluate environmental and socioeconomic indicators across the supply chain for three cellulosic and algal bioenergy production systems to validate greenhouse gas reduction of at least 50% compared to petroleum, socioeconomic benefits including job creation, water consumption equal to or less than petroleum per unit fuel produced, and wastewater and air emissions that meet federal regulations.

The performance milestones for the pathways under investigation are as follows:

Sustainability Analysis and Communication

- By 2015, identify practices that improve sustainability and environmental performance of advanced bioenergy, including results from a comprehensive case study of environmental, social, and economic sustainability indicators for a cellulosic feedstock production and biorefinery system
- By 2016, coordinate with feedstock logistics and conversion R&D areas to set targets for greenhouse gas emissions, consumptive water use, wastewater, and air emissions for at least three renewable hydrocarbon pathways to be validated in 2017 and 2022.

Sustainable System Design

- By 2015, identify conditions under which a national 2030 feedstock production scenario can be achieved that, when compared to the projected USDA baseline, improves average water quality in major feedstock production regions; does not increase consumptive water use per unit fuel produced; maintains soil quality and biodiversity; and does not impact projected needs for food, feed, and fiber production⁷⁸
- By 2018, using available field data, validate case studies of feedstock production systems that reduce greenhouse gas emissions and maintain or improve water quality and soil quality compared to conventional agriculture and forestry systems; identify generalizable conclusions and strategies to translate optimized scenarios into practice.

2.4.3 Sustainability Challenges and Barriers

St-A. Scientific Consensus on Bioenergy Sustainability: While there is agreement on the general definition of sustainability, there is no consensus on its specific definition and ways to quantitatively measure bioenergy sustainability (such as approaches, system boundaries, and time horizons).

St-B. Consistent and Science-Based Message on Bioenergy Sustainability: The prevalence of misrepresentations of the effects of bioenergy—including assumptions, scenarios, and model

⁷⁷ Here, landscape design refers to a holistic management process that incorporates bioenergy into existing land uses while maintaining or enhancing the environmental, economic, and social benefits that the landscape provides. Increasing land-use efficiency refers to integrating bioenergy systems in a manner that generates more services relative to required inputs.

⁷⁸ See “U.S. Billion-Ton Update.” Feedstock production scenario will be consistent with most current feedstock supply projections.

projections that lack empirical underpinnings—creates confusion about the costs and benefits of bioenergy production and leaves the industry vulnerable to criticism.

St-C. Sustainability Data across the Supply Chain: A fundamental hurdle to improving the sustainability of bioenergy production is the lack of consistent data to evaluate sustainability and compare one biofuel or bioenergy pathway with another. The lack of adequate and accessible temporal and spatial data for measuring sustainability also hinders other critical activities, such as establishing baselines, determining targets for improvement, recommending best practices, and evaluating tradeoffs.

St-D. Implementing Indicators and Methodology for Evaluating and Improving Sustainability: Significant progress has been made in developing a science-based framework for evaluating bioenergy sustainability through environmental and socioeconomic indicators and conducting LCAs to determine the impacts of bioenergy relative to other energy alternatives. The remaining challenge is to implement that framework to assess and improve sustainability with appropriate consideration of spatial, temporal, and other context-specific factors.

St-E. Best Practices and Systems for Sustainable Bioenergy Production: Because bioenergy production from cellulosic and algal feedstocks is relatively new, few “best practices” and sustainable systems are defined for all components of the bioenergy supply chain. Improved practices must be developed and deployed and their effectiveness demonstrated at larger scales and in a variety of contexts.

St-F. Systems Approach to Bioenergy Sustainability: The sustainability of the entire supply chain is not adequately considered in assessments of technical feasibility and economic optimization. Limited tools exist to allow researchers to consider the potential synergies and tradeoffs among different goals (such as energy security, biodiversity protection, or low-cost commodities) and different types of bioenergy systems.

St-G. Land-Use and Innovative Landscape Design: The limitations of existing data sources to capture the dynamic state of land use and management and an incomplete understanding of the drivers of land-use and management changes have undermined efforts to assess the environmental and social effects of bioenergy. Science-based, multi-stakeholder strategies are needed to proactively design and manage landscapes to enhance benefits and minimize negative impacts.

2.4.4 Sustainability Approach for Overcoming Challenges and Barriers

The approach for overcoming biomass sustainability technical challenges and barriers is outlined in the Sustainability Technology Area’s WBS, as shown in Figure 2-37. The WBS is organized around two areas: Sustainability Analysis and Communication and Sustainable System Design.

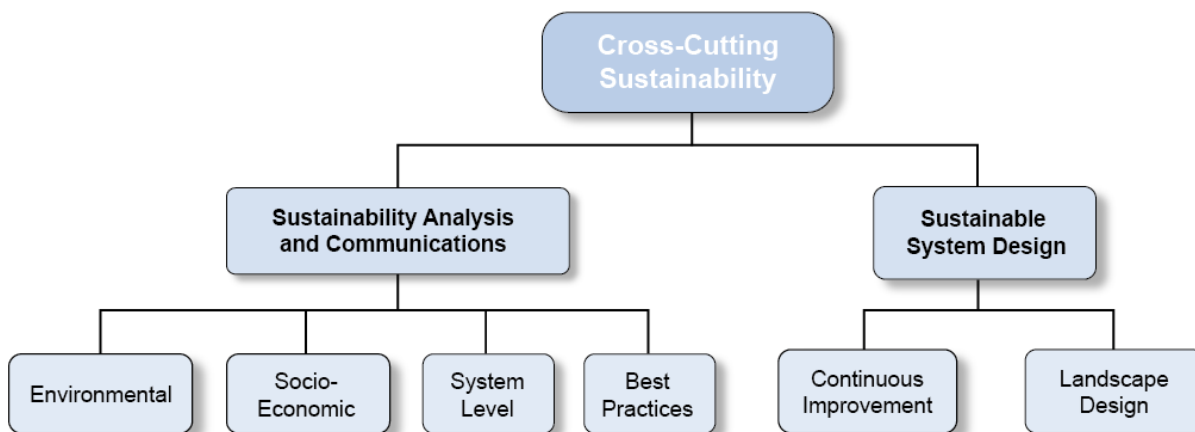

Figure 2-37: Sustainability work breakdown structure

The approach of each Sustainability WBS task element is described below and in Table 2-14. Each element is defined by its primary objectives; however, the two elements are interconnected, and outcomes in one inform activities in another. Both elements seek to develop or identify better practices, assess opportunities for improvement, disseminate technical information, and promote adoption of responsible practices through outreach and communication.

Both WBS elements contain linkages with the Office's technology areas (Terrestrial and Algal Feedstocks Supply and Logistics R&D, Conversion R&D, and Demonstration & Deployment). This includes collecting and evaluating technology-specific data and developing strategies to improve the environmental performance, resilience, and sustainability of bioenergy systems. For instance, the Office is exploring innovative strategies to reduce supply risks and the delivered cost of feedstocks to biorefineries through highly integrated feedstock production system designs.

Sustainability Analysis and Communication

This area focuses on collecting and integrating data, developing analyses and decision-support tools, and synthesizing and communicating information. Activities include measuring and evaluating sustainability through appropriate indicators and metrics, as well as integrative and spatial analyses of bioenergy production scenarios at different geographic scales (field, regional, national, and global) to investigate environmental, economic, and social impacts. Analyses also investigate trends and tradeoffs across multiple supply chain components and sustainability categories. Analyses reflect the latest empirical and modeled data from within and outside the Office's portfolio. Comparing new bioenergy technologies with current and evolving global bioenergy systems is also important; such comparisons enable the Office to assess performance against benchmark systems from other major bioenergy-producing countries.

Results generated from Sustainability Analysis and Communication activities are used by the Office to inform technology RDD&D to maximize beneficial outcomes. Results and best practices are also disseminated and promoted through publications, interagency interactions, and stakeholder outreach. This includes providing scientific input to bioenergy-relevant certification schemes and standards, such as the Roundtable on Sustainable Biomaterials and the International

Organization for Standardization. International collaborations enable the Office to stay informed of international market developments that affect the U.S. bioenergy industry, as well as help ensure that the U.S. perspective and scientific contributions are represented.

Sustainable System Design

This area focuses on performing sustainability field research and data generation, testing innovative concepts, and developing new practices that maintain or improve the environmental and socioeconomic sustainability of bioenergy. Activities include developing innovative methods for spatial and multi-metric optimization, developing and testing landscape design approaches for bioenergy, and demonstrating continuous improvements over time. As better practices are developed and validated, they are incorporated into the Office's technology evaluation approach, encouraged within the Office's RDD&D portfolio, and promoted through interagency coordination and domestic stakeholder interactions.

Table 2-14: Sustainability Activity Summary

WBS Element	Description	Barrier(s) Addressed
Sustainability Analysis and Communication	Collect and analyze data, develop decision-support tools, identify trends, and evaluate tradeoffs among different indicators and pathways. Use results to inform technology RDD&D, best practices, and outreach activities. Disseminate findings and best practices through publications, interagency interactions, and stakeholder outreach.	See below
Environmental	<ul style="list-style-type: none"> - Assess baselines and targets across environmental categories (greenhouse gas emissions, water, soil quality, air quality, and biodiversity) for cellulosic and algal feedstock production, logistics, and conversion technologies. - Evaluate indicator values across technology types and over time. - Conduct integrative and spatial analyses to investigate environmental effects at various scales. 	St-A: Scientific Consensus St-B: Consistent, Evidence-Based Message St-C: Sustainability Data across the Supply Chain St-D: Indicators and Methodology St-G: Land-Use and Innovative Landscape Design
Socioeconomic	<ul style="list-style-type: none"> - Identify relevant socioeconomic sustainability indicators and evaluate indicator values across technology types and over time. - Conduct integrative and spatial analyses to investigate effects at various scales. 	St-A: Scientific Consensus St-B: Consistent, Evidence-Based Message St-C: Sustainability Data across the Supply Chain St-D: Indicators and Methodology St-G: Land-Use and Innovative Landscape Design
System-Level Sustainability	<ul style="list-style-type: none"> - Complete multivariate assessments that integrate environmental, social, and economic indicators to assess system-level sustainability. 	St-C: Sustainability Data across the Supply Chain St-D: Indicators and Methodology St-F: Systems Approach to Bioenergy Sustainability St-G: Land-Use and Innovative Landscape Design
Promoting Best Practices	<ul style="list-style-type: none"> - Identify and communicate best practices across Office portfolio, through interagency coordination, and through domestic and international stakeholder interactions. 	St-C: Sustainability Data across the Supply Chain St-D: Indicators and Methodology St-E: Best Practices St-F: Systems Approach to Bioenergy Sustainability St-G: Land-Use and Innovative Landscape Design
Sustainable System Design	Develop and test innovative concepts, practices, and technologies that maintain or enhance environmental, economic, and social sustainability of bioenergy.	See below
Continuous Improvement	<ul style="list-style-type: none"> - Develop processes by which sustainability measurement and evaluation leads to changes in practices and behavior. - Develop iterative, empirically based mechanisms that support continuous improvements in sustainability. 	St-D: Indicators and Methodology St-E: Best Practices St-F: Systems Approach to Bioenergy Sustainability St-G: Land-Use and Innovative Landscape Design
Landscape Design	<ul style="list-style-type: none"> - Identify optimized bioenergy production strategies across environmental, economic, and social factors. - Conduct field research on best management practices, develop and test landscape design approaches for bioenergy, and demonstrate more sustainable practices at larger scales. 	St-C: Sustainability Data across the Supply Chain St-D: Indicators and Methodology St-E: Best Practices St-F: Systems Approach to Bioenergy Sustainability St-G: Land-Use and Innovative Landscape Design

2.4.5 Prioritizing Sustainability Barriers

The following issues are critical and will be emphasized within near- to mid-term Sustainability efforts:

- Advance scientific methods and models for measuring and understanding bioenergy sustainability across the full supply chain
- Disseminate practical tools that support analyses, decision making, and technology development
- Identify, develop, and promote practices that enhance sustainable bioenergy outcomes
- Develop landscape design approaches that increase bioenergy production while maintaining or enhancing ecosystem and social benefits.

To enable data-driven prioritization of sustainability efforts, the Office follows a framework that can be applied to biomass and bioenergy production systems at different scales and contexts, as illustrated in Figure 2-38. This framework helps guide activities for data generation, data collection, and evaluation of current and future scenarios. The framework also is used to develop management practices and technologies that maintain or improve environmental performance and socioeconomic benefits.

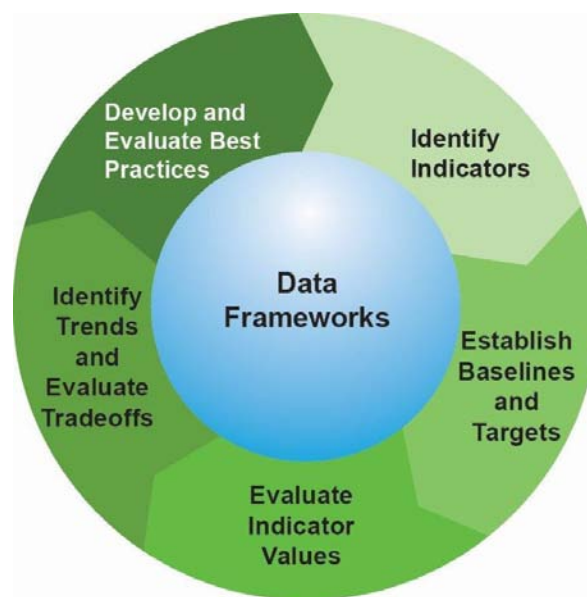

Figure 2-38: Sustainability activities

Implementation of this framework, as described in the following steps, primarily focuses on the categories shown in Figure 2-39. These categories are meant to illustrate the predominant sustainability considerations addressed through Office activities, but they are not exhaustive.

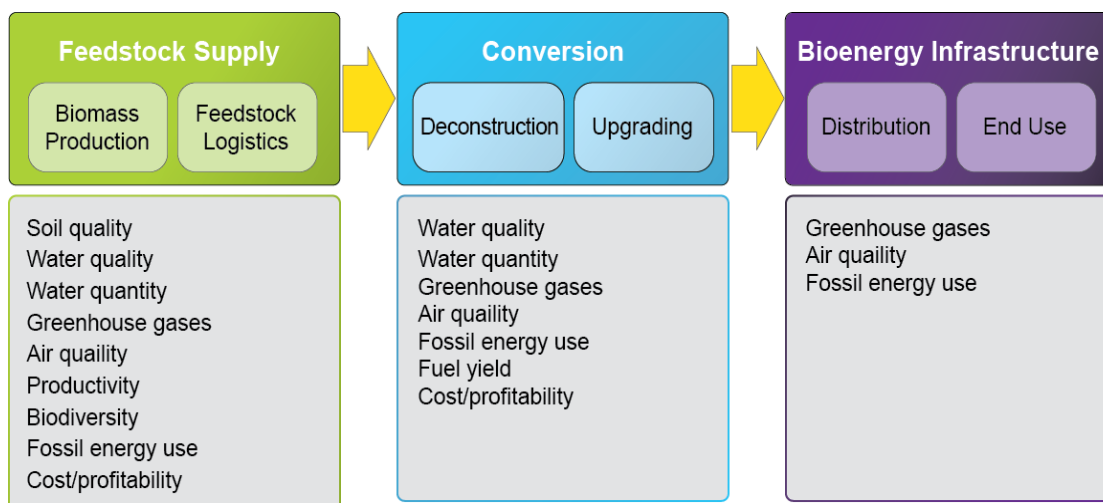

Figure 2-39: Sustainability considerations by supply chain component

- **Identify appropriate indicators and metrics** based on the spatial context and type of biomass/bioenergy system, as well as sustainability goals and selection criteria (e.g., cost of data collection and verification, attribution, comparability across pathways, consistency across agencies, etc.). More information on sustainability indicators for bioenergy are described in McBride et al. 2011 and Dale et al. 2012.^{79,80}
- **Establish baseline and target conditions** consistent with the goals and scales (temporal and spatial) of effects to be measured. Baselines may represent the current bioenergy industry, “business as usual” conditions, or non-optimized systems. Establish relevant sustainability targets based on acceptable, improved, or optimized outcomes. Appropriate targets depend on the type of project and the Office’s ability to influence indicator values:
 - *Scenario Analysis Targets:* Analysis projects develop regional or national scenarios of biomass/bioenergy production to investigate aggregate impacts. Targets reflect beneficial and/or optimized future scenario(s) and can help guide what technology improvements or practices are necessary to best enable meeting beneficial, intended objectives.
 - *Pathway-Specific Targets:* Within the feedstock logistics and conversion R&D areas, sustainability metrics are being assessed alongside the techno-economic parameters and will be increasingly incorporated into SOT assessments as more data are available (see the Thermochemical Conversion R&D section, Figure 2-23). Similar to the cost and technical targets, setting targets for greenhouse gases, air emissions, water consumption, and other relevant sustainability metrics helps promote technologies that achieve multiple economic, technical, and environmental goals.
 - *Site/Project-Specific Targets:* Research and field projects establish site-specific targets that reflect acceptable conditions (e.g., level of soil organic carbon) or

⁷⁹ McBride A., V.H. Dale, L. Baskaran, M. Downing, L. Eaton, R.A. Efroymson, C. Garten, K.L. Kline, H. Jager, P. Mulholland, E. Parish, P. Schweizer, J. Storey. (2011). “Indicators to support environmental sustainability of bioenergy systems.” *Ecological Indicators* 11(1).

⁸⁰ Dale, V.H., R.A. Efroymson, K.L. Kline, M.H. Langholtz, P.N. Leiby, G.A. Oladosu, M.R. Davis, M.E. Downing, M.R. Hilliard. (2013a). “Indicators for assessing socioeconomic sustainability of bioenergy systems: A short list of practical measures.” *Ecological Indicators* 26(1).

potential for improvement (e.g., reduce nitrogen runoff by 5%). These targets help define practices or guide development of new practices that promote viable operations.

- **Evaluate indicator values** based on established monitoring protocols and consideration of relationships among each supply chain element and indicator. Document status of factors that induce changes in indicator values. Document the presumed degree to which Office intervention can impact indicator values.
- **Identify trends and evaluate tradeoffs** between different indicators and pathway elements. Trends refer to changes in values of sustainability indicators over time. Hypotheses can be developed for forces influencing those trends and tested against relevant empirical data. Tradeoffs between achieving different targets can be explored as a way to improve sustainability.
- **Develop and evaluate best practices based on monitoring, field data, and modeling results.** Compare practices with empirical data to support continuous improvement in sustainability. Review objectives, indicator values and definitions, and best practices upon changing conditions, priorities, and new knowledge. As practices are evaluated for effectiveness, they can be applied to additional projects, locations, and production systems.
- **Maintain data frameworks** for data collection, integration, and visualization to support analysis, research, and adaptive management.

2.4.6 Sustainability Milestones and Decision Points

The key milestones and decision points to complete the tasks described in Section 2.4.4 are summarized in Figure 2-40.

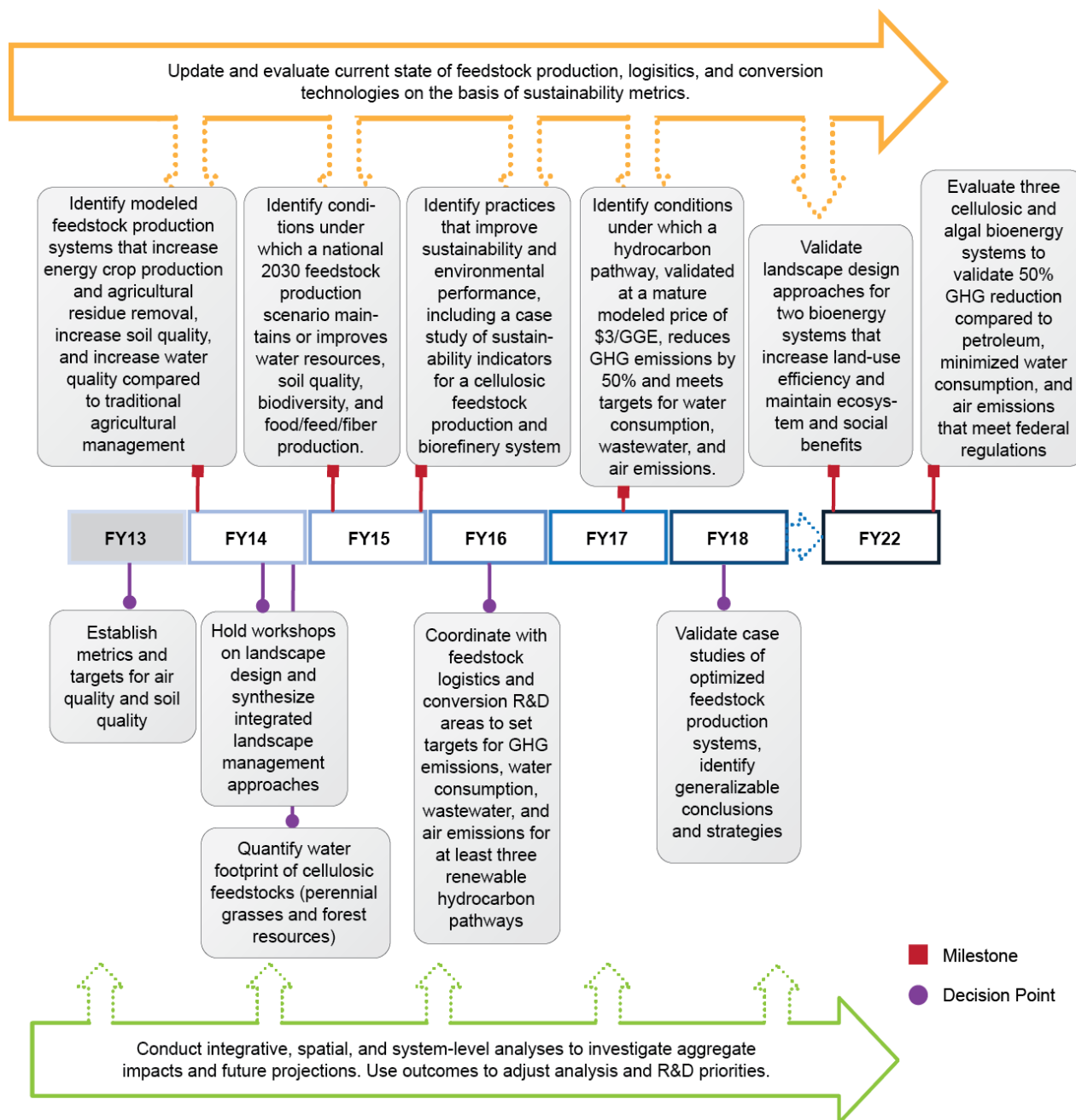

Figure 2-40: Sustainability key milestones and decision points

2.5 Strategic Analysis

Strategic Analysis helps determine overall Office goals and priorities and covers issues that cut across all technology areas. System-level analyses inform strategic direction and planning efforts; they also help the Office focus its technology development priorities and identify key drivers and hurdles for industry growth. Technology-specific analyses explore sensitivities and identify areas where investment may lead to the greatest impacts.

The Strategic Analysis Technology Area plays four main roles in the Office's decision-making process:

- Provides the analytical basis for planning and assessment of progress
- Defines performance targets and validation strategy for biomass technologies and systems
- Conducts system-level policy, industry, and environmental analyses relevant to bioenergy
- Reviews and evaluates external analyses and studies.

Maintaining these capabilities at the cutting edge ensures that the analysis provides the most efficient and complete answers to internal and external stakeholders. Coordinated multi-lab efforts and continued partnerships with the biomass industry and scientific community help ensure that the Office's analysis results are peer reviewed, transferable, and comparable.

The majority of Strategic Analysis activities are designed to support Office decision-making processes and track milestones. They validate decisions, ensure objective inputs, and respond to external recommendations. Supporting activities in the Strategic Analysis portfolio strive to advance the state of the science within areas such as land-use change modeling, impact analysis, and LCA. The Office provides ongoing analysis and policy support to other U.S. government agencies and legislative bodies. Emerging issues, interests, and trends raise new questions from a wide variety of stakeholders, including DOE management, members of Congress, other federal agencies, and state governments. Scholarly articles, popular media, and other broader forums are additional sources of questions for analysis.

Figure 2-41 shows how the Strategic Analysis Technology Area supports all elements of the biomass-to-bioenergy supply chain.

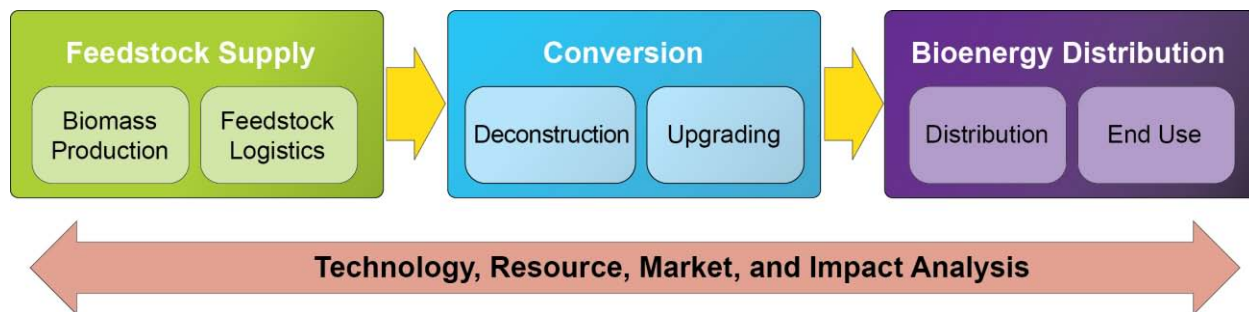

Figure 2-41: Strategic Analysis supports the entire supply chain

2.5.1 Strategic Analysis Support of Office Strategic Goals

The strategic goal of the Strategic Analysis Technology Area is to provide context and justification for decisions at all levels by establishing the basis of quantitative metrics, tracking progress toward goals, and informing portfolio planning and management.

2.5.2 Strategic Analysis Support of Office Performance Goals

The overall performance goals for the Strategic Analysis Technology Area are as follows:

- Ensure high-quality, consistent, reproducible, peer-reviewed analyses
- Develop and maintain analytical tools, models, methods, and datasets to advance the understanding of bioenergy and its related impacts
- Convey the results of analytical activities to a wide audience, including DOE management, Congress, the White House, industry, other researchers, other agencies, and the general public.

Strategic Analysis activities are ongoing; however, the following key milestones will provide the analytical basis for out-year targets and R&D activities for meeting those targets:

- By 2014, coordinate the delivery of new design cases and corresponding LCAs for at least two technology pathways for conversion of biomass to hydrocarbon biofuels
- By 2015, complete an assessment of the size and composition of current and potential markets for biofuels and bioproducts
- By 2016, develop and deploy a consistent methodology for including co-products in TEAs and design cases
- By 2017, identify near-term technology pathways for the Office based on reassessment of current SOT development
- By 2018, complete analysis on impact of advanced biofuels use on gasoline and diesel prices
- By 2022, identify near-term technology pathways for the Office based on reassessment of current SOT development.

2.5.3 Strategic Analysis Challenges and Barriers

Several factors impact the understanding of key drivers and implications for developing and sustainably deploying new biomass technologies. These include the following:

At-A. Comparable, Transparent, and Reproducible Analyses: Analysis results are strongly influenced by the datasets employed, as well as by the assumptions and guidelines established to frame the analysis. Standardized datasets, assumptions, and guidelines are needed to compare and integrate analysis results.

At-B. Analytical Tools and Capabilities for System-Level Analysis: High-quality analytical tools and models are needed to enable the understanding of broader bioenergy supply-chain-wide systems, linkages, and dependencies. Models need to be developed and refined to improve

understanding of these issues and their interactions. Improvements in model components and in linkages are necessary to improve utility and consistency.

At-C. Data Availability across the Supply Chain: Understanding the biomass-to-bioenergy supply chain and its economic, environmental, and other impacts requires complete and comparable data. Filling data gaps and improving data accessibility would improve efforts to understand all relevant dimensions of bioenergy production and use.

2.5.4 Strategic Analysis Approach for Overcoming Challenges and Barriers

The WBS shown in Figure 2-42 and Table 2-15 show the types of analysis activities undertaken by the Office. Strategic Analysis activities are inherently cross-cutting and interface with all other technology areas within the Office. The descriptions below discuss the models and methods used for the various types of analysis conducted by national laboratories, universities, and DOE.

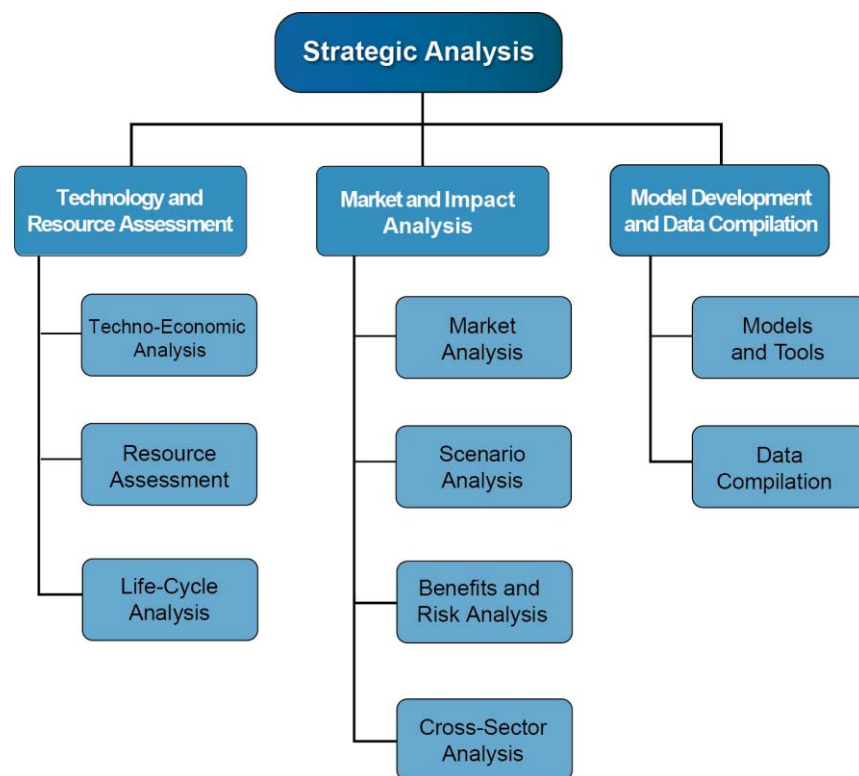

Figure 2-42: Strategic Analysis work breakdown structure

Technology and Resource Assessment

Techno-Economic Analysis: The Office assesses the technical and economic viability of new processes and technologies, identifies the potential for cost reduction, assesses cross-pathway and cross-technology progress, and provides input into portfolio development and technology validation. Technology and economic analysis methods and tools used include

unit operation design flow and information models, process design and modeling (e.g., Aspen Plus®⁸¹), capital costs (e.g., Aspen Capital Cost Estimator®⁸²) and operating cost⁸³ determination, discounted cash-flow analysis, and Monte Carlo sensitivity analysis/risk assessment. The Office also assesses the potential cost reductions that can be achieved as the advanced biofuels industry develops and increases capacity beyond first-of-a-kind pioneer facilities. This ongoing analysis effort applies learning rates from relevant, more established industries to estimate the range of possible cost reductions as conversion technologies are commercialized and replicated.

Resource Assessment: Feedstock supply resource assessments identify the geographic location, price, and environmental sustainability of accessing existing and potential future feedstock resources, as well as projecting future supply availability and prices. Strategic Analysis activities utilize these data to understand price effects of competition from various biomass utilization technologies (e.g., biofuel versus biopower), as well as to assess cross-technology impacts of feedstock cost, quantity, and quality.

Life-Cycle Analysis: The Strategic Analysis Technology Area supports Office sustainability efforts through developing and maintaining life-cycle and land-use change models to estimate the environmental impacts of biomass production and utilization technologies. LCA models identify and evaluate the emissions, resource consumption, and energy use of various processes, technologies, or systems to help understand the full impacts of existing and developing technologies and prioritize efforts to mitigate negative effects. The GREET model⁸⁴ is used to estimate fuel-cycle energy use and emissions associated with alternative transportation fuels and advanced vehicle technologies. Strategic Analysis supports updates and enhancements to the GREET model to continually reflect new and evolving bioenergy technologies. Strategic Analysis also supports efforts to better understand and characterize the complex drivers of land-use change and gather more accurate land-use data.

Market and Impact Analysis

Market Analysis: Market assessment helps the Office focus its technology development priorities in the near, mid, and long term by analyzing the potential cost, commercialization time, and market demands for candidate biofuels, biopower, and bioproducts. This analysis draws on a broad range of other analyses, including fossil fuel cost projections; future energy demand forecasts; infrastructure assessments; state of biomass utilization technology development; national and local sustainability analysis; and consumer, economic, and policy

⁸¹ Aspen Plus® is a process modeling tool for steady-state simulation, design, performance monitoring, optimization, and business planning widely used in the chemicals, specialty chemicals, petrochemicals, and metallurgy industries. More information is available at <http://www.aspentech.com/>.

⁸² For information, see <http://www.aspentech.com>.

⁸³ As an example, chemical supply costs are taken from *The Chemical Marketing Report* and labor costs from related industries, such as corn ethanol production.

⁸⁴ For information, see <http://greet.es.anl.gov/>.

scenarios. This analysis also helps identify current and future market attractiveness, gaps, strengths, and risks that may impact producer, investor, and consumer decision making.

Scenario Analysis: Understanding the impacts of changes and development of various elements of the biomass-to-bioenergy supply chain is the key to informing technology portfolio planning and monitoring progress toward national goals. To help understand which supply chain modifications have the greatest potential to accelerate deployment of biofuels, the Office has supported development of the Biomass Scenario Model (BSM). The BSM is a systems dynamics model for conducting biofuels policy analysis through investigation of the systemic effects, linkages, and dependencies across the biomass-to-biofuels supply chain. Figure 2-43 shows the conceptual structure of the model and an overview of the module for each supply chain component. The model considers pathways from starch, lignocellulosic, oilseed, and algal feedstocks to ethanol, butanol, gasoline, diesel, and aviation fuel.

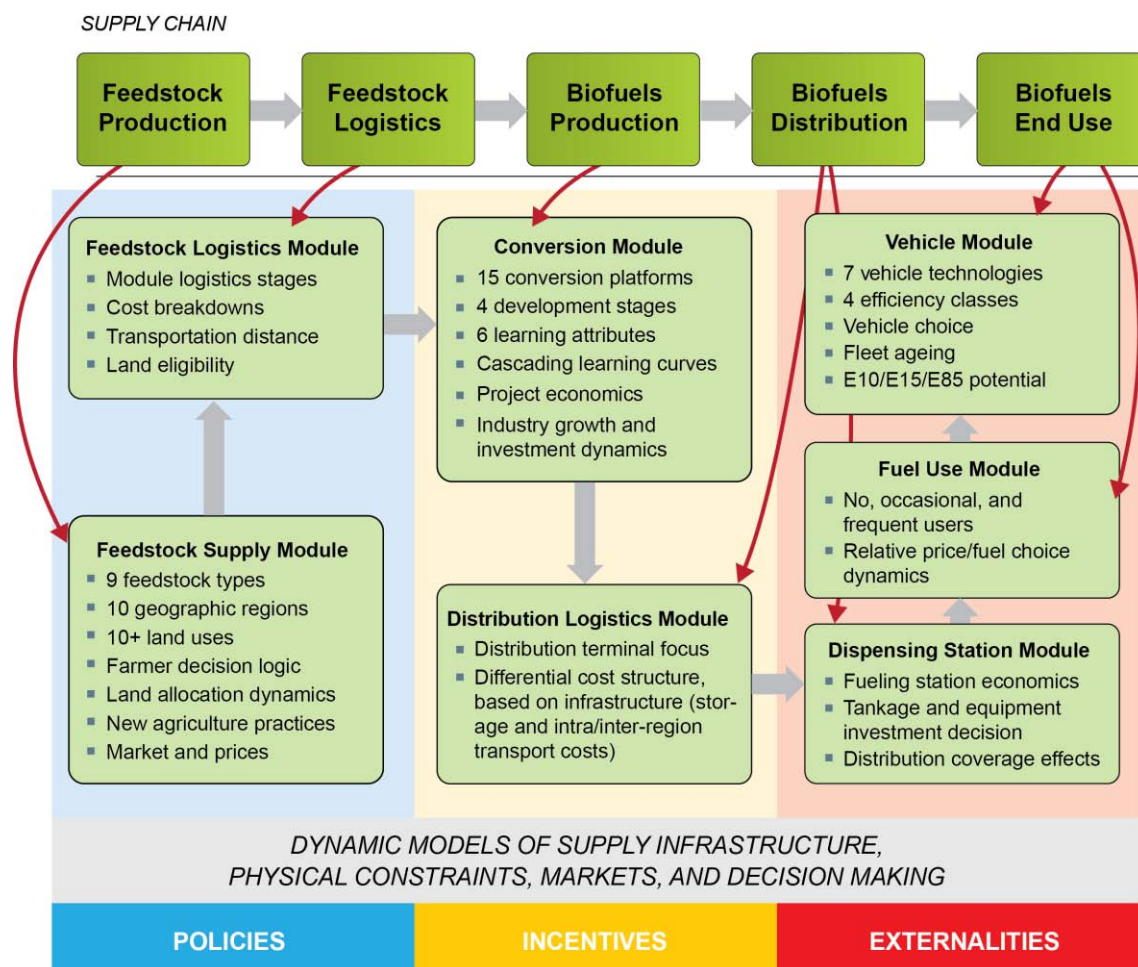

Figure 2-43: Conceptual schematic of the Biomass Scenario Model

Benefits and Risk Analysis: Benefits analysis helps the Office quantify and communicate the long-term benefits of biomass RD&D (e.g., imported oil displacement and greenhouse gas mitigation). The scenarios developed and the quantified costs and benefits are used to evaluate the most viable biomass utilization technologies and routes. Results are also used in

cross-cutting benefits analysis and are a key input to EERE renewable technology portfolio decision making. Risk analysis helps the Office quantify the impact of investments on technology risk over time.

Cross-Sector Analysis: A growing bioenergy industry affects and is affected by other renewable energy and transportation efficiency technologies. Cross-sector analysis includes collaborations with other EERE offices and federal agencies to explore future scenarios for transportation sector growth.

Model Development and Data Compilation

Models and Tools: The Office supports the development and deployment of new analytical tools and methods and guides the selection of assumptions and methodologies to be used for all analyses to ensure consistency, transparency, and comparability of results.

Data Compilation: Many disciplines and sectors are involved in bioenergy RD&D. Developing, compiling, maintaining, and providing easy access to the best available, credible data, models, and visualization tools is critical to supporting sustainable commercialization of biomass utilization technologies. To serve this need, the Office developed the Bioenergy Knowledge Discovery Framework (KDF),⁸⁵ a Web-based data repository, visualization tool, and library. The goal of the KDF is to facilitate planning, development, and management decisions by providing a means to synthesize, analyze, and visualize vast amounts of information in a relevant and succinct manner. The KDF's GIS-based data analysis, mapping, and visualization components draw from dynamic and disparate databases of information to enable users to analyze economic, social, and environmental impacts of various biomass utilization technologies for biomass feedstocks, biorefineries, and infrastructure.

2.5.5 Strategic Analysis Milestones and Decision Points

The key milestones and decision points to complete the tasks described in Section 2.5.4 are summarized in Figure 2-44.

⁸⁵ For more information, visit <https://bioenergykdf.net/>.

Table 2-15: Strategic Analysis Activity Summary

WBS Element	Description	Barrier(s) Addressed
Technology and Resource Assessments	<ul style="list-style-type: none"> - Assess quantity and associated costs of biomass resources. - Assess life-cycle greenhouse gas and air quality impacts of new biofuel pathways and integrate into technical and economic assessments. - Comparative technical and economic assessment of biofuels. - Support the comprehensive integration of annual SOT assessments. - Support feedstock-pathway-wide TEA. 	At-A: Comparable, Transparent, and Reproducible Analysis At-B: Analytical Tools and Capabilities for System-Level Analysis At-C: Data Availability
Market and Impact Analysis	<ul style="list-style-type: none"> - Determine the cost, timing, and market demands for candidate biofuels and biocrudes. - Assess impacts of changes and development of various elements of the biomass-to-bioenergy supply chain and identify impacts of supply chain modifications on deployment of biofuels. - Evaluate and document impact of biofuels on U.S. economies and environment. - Identify, quantify, and evaluate uncertainty and risk of biofuels. 	At-A: Comparable, Transparent, and Reproducible Analysis At-B: Analytical Tools and Capabilities for System-Level Analysis At-C: Data Availability
Model Development and Data Compilation	<ul style="list-style-type: none"> - Ensure results of analytical and research activities are available through the KDF. - Develop new analytical tools and methods, as needed, to address emerging needs. - Establish and maintain standardized assumptions and methods. 	At-B: Analytical Tools and Capabilities for System-Level Analysis At-C: Data Availability

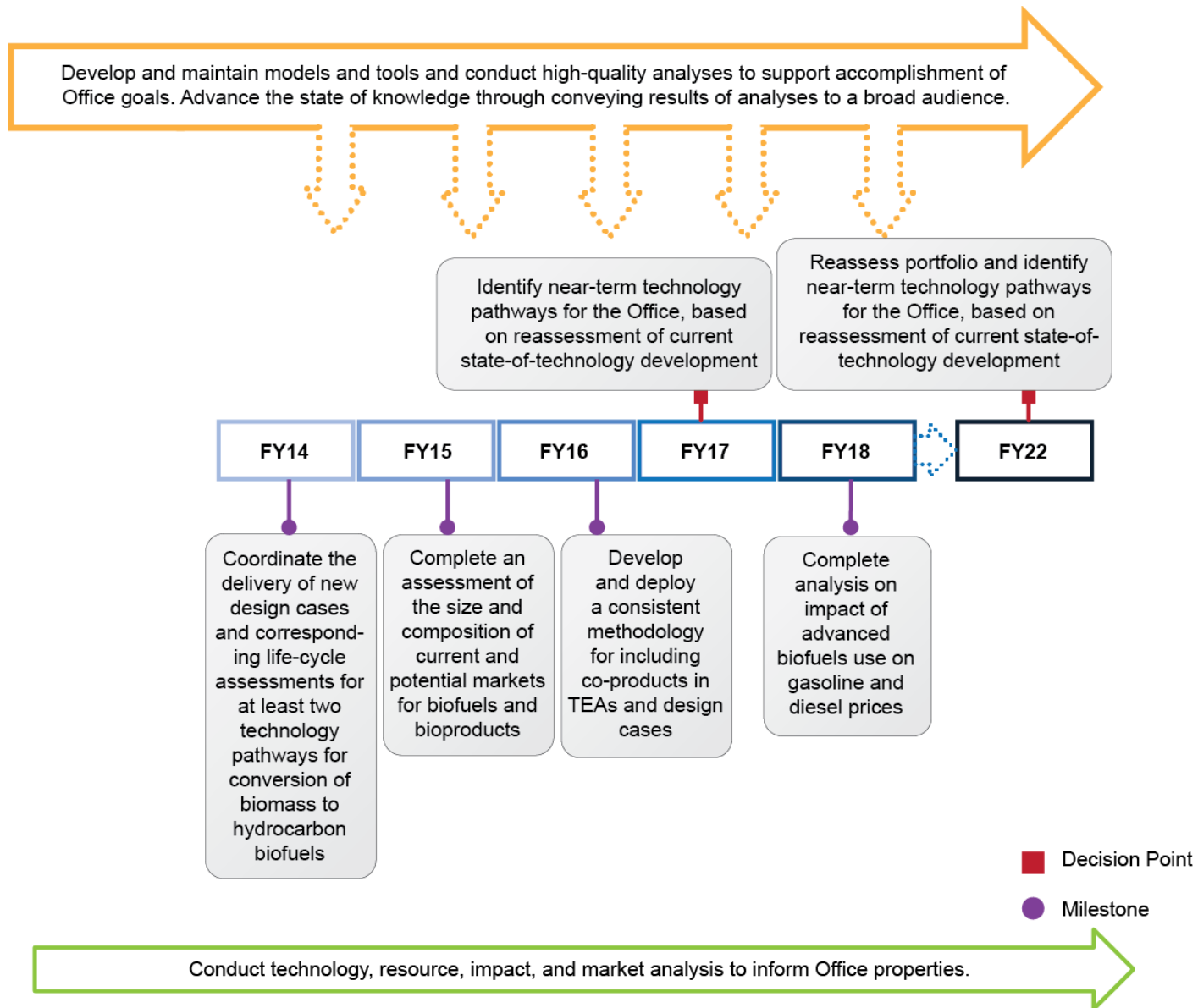

Figure 2-44: Strategic Analysis key milestones and decision points

2.6 Strategic Communications

The Office's Strategic Communications area is focused on identifying and addressing market and other non-technical barriers to bioenergy adoption and utilization in an effort to reach full-scale market penetration. The activities performed in support of these efforts are geared toward fostering greater stakeholder, public, and congressional awareness and acceptance of significantly increased production of sustainable biofuels, bioproducts, and biopower. This increased production is needed to replace the whole barrel of oil, thus displacing petroleum products and reducing greenhouse gas emissions. Together, these reduce our dependence on foreign oil and secure our nation's economic and energy future. Accordingly, Strategic Communications engages a range of stakeholders in meaningful collaborations, promotes the accomplishments of RD&D projects in first-of-a-kind technologies, increases consumer acceptance, and accelerates the expansion of bioenergy production and use.

Strategic Communications includes distributing technical and non-technical information to internal and external stakeholders through a number of channels, including traditional media; digital media, such as website content; social media; and conferences and events. In addition to conveying key Office goals, priorities, activities, and accomplishments, Strategic Communications also focuses on creating and maintaining public awareness, as well as promoting bioenergy production and use. Informational outreach is targeted at keeping various internal and external stakeholders informed about Office investment strategies, accomplishments, and technologies. Motivational outreach efforts are intended to stimulate demand for and partnership in developing industries that will make up the future bioeconomy.

The Office's target audiences include scientists, engineers, and researchers; industry and investors across the entire bioenergy supply chain; policy makers at all levels of government, including members of Congress and their staffs; the American public, specifically educators and students; and members of rural and farming communities.

The Office's key audiences vary greatly in terms of their level of understanding and opinions about the benefits of sustainable biofuels, bioproducts, and biopower industries. The effectiveness of Office communication efforts is challenged by the information clutter from an increasing number of available communication channels, many of which are designed, over time, to self-engineer and be personalized to unique audience preferences.

Strategic Communications recognizes the growing need for targeted messaging initiatives that align outcome-based messaging frameworks with traditional and emerging communication delivery channels. This requires ongoing analysis that plans and measures outreach efforts that are mapped for specific audiences while simultaneously ensuring integration with other audience initiatives. Desired benefits of this approach target both internal and external audiences to accomplish the following:

- Improve decision making and implementation across BETO programs
- Increase information alignment and bioenergy technology adoption across target audiences

- Proactively diffuse conflicts and conflicting messaging
- Increase opportunities to combine efforts for cumulative impact and higher return on investment.

There are a number of stakeholder classes identified as key to bioenergy industry expansion. As the portfolio of American energy resources diversifies, there is increased competition for market shares, and the current national media landscape demonstrates the need for effective communication campaigns that reach the general public as congressional constituents and consumers of biofuels, bioproducts, and biopower.

Education and Workforce Development

The younger generations are critical stakeholders in the nation's future energy security, and targeted outreach to this audience is important as they prepare to become tomorrow's leaders, select and train for careers, and drive future demand for renewable energy products. As bioenergy technologies emerge in industry and the market transforms, there will also be a need for education and training on the safety, health, and environmental issues related to the transport and use of biofuels, bioproducts, and biopower.

As part of its outreach, the Office can play a significant national role in building this workforce and fostering demand for bioenergy products by engaging America's youth and young adults. Many of the Office's education and workforce development planning and activities are led, coordinated, and/or supported by the Strategic Communications team. Amplifying the Office post-doctoral fellowship and internship programs are part of these activities.

2.6.1 Strategic Communications Support of Office Strategic Goals

The strategic goal of the Strategic Communications Area is *to support and enhance the Office's mission by conducting strategic outreach to target audiences that promotes the benefits of sustainable production of biofuels, bioproducts, and biopower, highlighting the role that a thriving bioeconomy plays in creating green jobs, spurring innovation, benefitting the environment, and achieving national energy security.*

2.6.2 Strategic Communications Support of Office Performance Goals

Strategic Communications aims to achieve the following performance goals and milestones:

- Increase awareness of and support for the Office's advanced biomass RD&D and technical accomplishments, highlighting their role in achieving national renewable energy goals.
 - On an annual basis, complete outreach efforts focused on celebrating specific and timely Office contributions to new technologies, pathways, and directions as Office-supported projects achieve important milestones and deliverables.
 - By the end of 2014, determine three key Office messages that will be amplified throughout all Office outreach.
 - By the end of 2014, complete outreach efforts focused on communicating the Office's successes in cellulosic ethanol to the ethanol-development community.

- By the end of 2014, in collaboration with Office leadership and EERE Strategic Programs, identify highest-value media and target audiences, and set goals for targeted outreach strategies and metrics that rely on appropriate communication channels (traditional and emerging) and carefully tailored messages and sub-messages.
- By the end of 2015, complete a national outreach campaign on the promise and benefits of developing biofuels, bioproducts, and biopower.
- Educate audiences about the environmental, economic, and social benefits of biomass as a viable alternative to fossil fuels, as well as the potential for advanced biofuels to displace petroleum-based transportation fuels.
 - By the end of 2014, complete outreach efforts focused on the greenhouse gas emission reductions resulting from biomass-derived alternative fuels.
 - By the end of 2015, complete outreach efforts focused on landscape-scale environmental benefits of integrated biomass-based alternative fuels production with agricultural and other industrial activities.
 - By the end of 2016, complete outreach efforts focused on future consumers and workforce that will support an emerging bioenergy industry.

2.6.3 Strategic Communications Challenges and Barriers

Accelerating the growth of the bioenergy economy requires addressing market barriers at local, state, and federal levels. Strategic Communications' activities are focused on addressing the following market challenges and barriers.

Ct-A. Lack of Acceptance and Awareness of Biofuels as a Viable Alternative Fuel: To succeed in the marketplace, biomass-derived fuels and chemical products must perform as well as or better than comparable petroleum- and fossil-based products. Industry partners and consumers must perceive the quality, value, sustainability, and safety of biomass-derived products and their benefits, relative to the risks and uncertainties that widespread changes will likely bring. Compared with other renewable technologies, consumer acceptance and awareness of biofuels and bioenergy technologies are varied. Vehicle and engine manufacturers are a particularly influential stakeholder group, as future sustainable transportation designs that work well with biofuels can increase market penetration significantly.

Currently, there is a well-organized and heavily funded campaign of misinformation about biofuels. Only trustworthy, accurate, and up-to-date information can refute these allegations and reassure the public that there are sufficient resources to produce biofuels, bioproducts, and biopower sustainably and economically while benefitting the environment and continuing to meet society's demand for food, feed, and fiber.

Ct-B. Poorly Understood Role of Government versus the Role of Industry: Government-funded R&D focuses on a broad range of emerging technologies. This approach supports a diverse technology portfolio and identifies the most promising targets for industry to pursue in follow-on, industrial-scale demonstration and deployment. Through grants and partnerships with universities, national laboratories, and research groups, the Office helps support basic research that would be too risky for any one private entity to pursue, while advancing the state of

technology development for the entire biomass industry. Once a technology reaches maturity, private industry entities are better equipped to aid in deploying that technology to end users.

Stakeholders and the general public often do not understand these distinct, necessary, and interdependent roles. For example, cellulosic ethanol is now near deployment, causing a shift in the Office's focus to less developed technologies, such as drop-in hydrocarbon biofuels. The Office will need to communicate this shift in focus to its audiences in a clear, transparent manner to avoid misconceptions about the success of cellulosic ethanol. Additionally, the Office must communicate its repositioning as a necessary step in the advancement of technology to meet national energy independence goals, including EISA goals, which will require a diverse array of biobased fuels and products.

Ct-C. Inconsistent and Unpredictable Policy Landscape and Priorities: The Office continues to support new, emerging technologies throughout a constantly changing policy, tax, and economic landscape. Communicating these shifting priorities effectively, accurately, and proactively is an ongoing challenge.

Ct-D. Increasing Information Clutter: As established energy commodities, conventional fossil fuel markets have extensive and compelling national communication campaigns promoting their products. There are also numerous new communication channels that are developing rapidly. While the 'Information Age' increases the reach of traditional media and targets new audiences, it also necessitates greater awareness of specific audience needs, expectations, and sensitivities in order for communication efforts to be effective. This exacerbates the other challenges and barriers and requires a multi-pronged strategic approach to deliver key messaging.

2.6.4 Strategic Communications Approach for Overcoming Challenges and Barriers

Strategic Communications uses a combination of internal and external communication methods that aid the office in disseminating its messages:

- Traditional media
- Website content
- New and digital media
- Conferences and events
- Internal communications

The approach for overcoming Strategic Communications challenges and barriers is outlined in Figure 2-45 and described below.

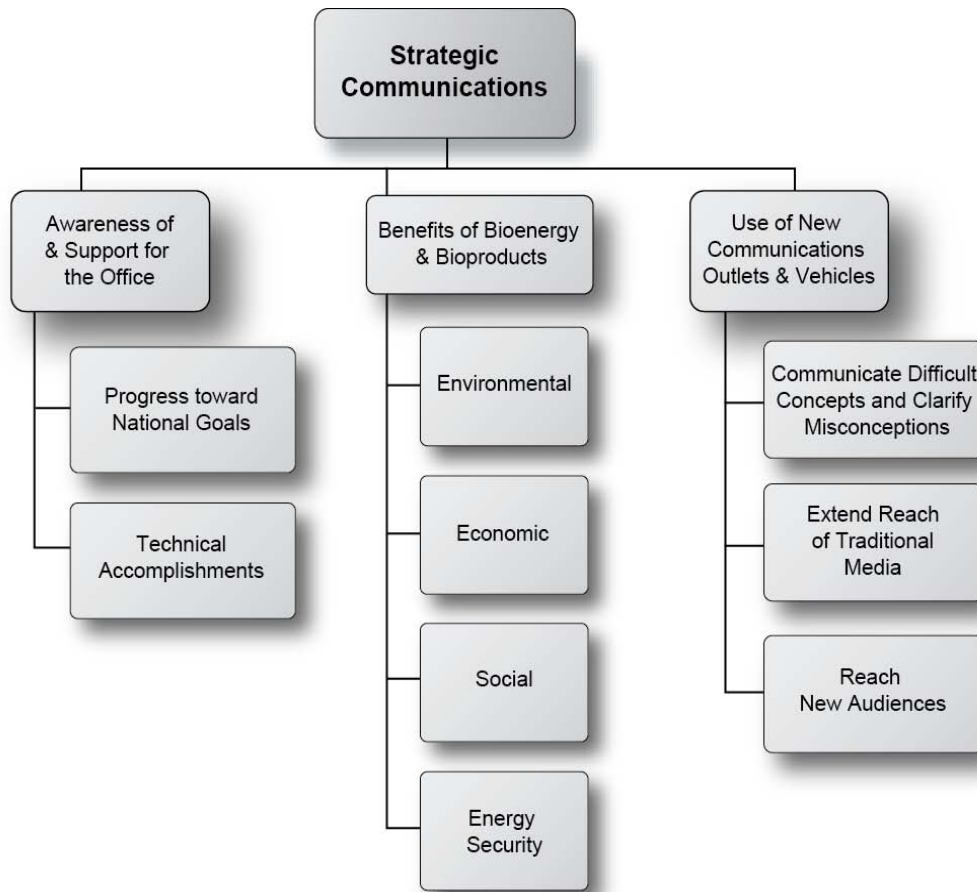

Figure 2-45: Strategic Communications Work Breakdown Structure

Increasing Awareness of & Support for the Office

These activities focus on informing target audiences about Office accomplishments, strategies, and technologies, while calibrating expectations of near- and medium-term RD&D achievements. Near-term activities in this area will focus on promoting the Office's cellulosic ethanol R&D accomplishments, alongside the shift in focus to other infrastructure-compatible fuels suitable for future modes of sustainable transportation. Mid-term activities will highlight deployment and demonstration efforts as first-of-a-kind commercial biorefineries begin and continue production. To disseminate this key messaging, the Office will establish a regular, open line of communication with target audiences through the GovDelivery listserv monthly news blast, the Office's website, press releases and progress alerts, social media, and other outreach channels.

Communicating the Benefits of Bioenergy and Bioproducts

These activities focus on deepening target audiences' understanding of the environmental, economic, social, and energy security benefits of biofuels, biopower, and bioproducts. Mid-term activities will target vehicle and engine manufacturers directly through targeted communication efforts and indirectly through consumer campaigns. The Office will continue its use of regularly scheduled webinars, fact sheets and other publications, the annual Bioenergy Technologies Office conference, and speaking opportunities at industry and partner events to support near- and

mid-term activities. Education and workforce development efforts will largely fall under this approach.

Use of New Communications Vehicles and Outlets

In addition to using traditional media, the Office has planned efforts to make more effective use of new and digital communication vehicles and outlets to address the challenges surrounding bioenergy and draw attention to positive perceptions, results, and accomplishments. Near-term efforts include strengthening communication about the Office's project portfolio by keeping regular lines of communication with target audiences through monthly social media posts and Office Blog posts. Other activities include disseminating Office messaging in graphical and interactive formats that promote understanding, including infographics and website widgets and animations. Long-term efforts include implementing various new channels to disseminate clear and consistent, targeted messaging that will increase the Office's reach beyond current stakeholders, while maintaining costs. This includes continuing to increase use of new and social media and third-party products.

Activities for Strategic Communications are outlined in Table 2-16 and Figure 2-46.

Table 2-16: Strategic Communications Activity Summary

WBS Element	Description	Barrier(s) Addressed
Awareness of & Support for the Office	Use various traditional and emerging media channels to increase awareness of and support for the Office's advanced biomass R&D and technical accomplishments.	
Progress Toward National Goals	Highlight the role the Office plays in achieving national goals, such as meeting EISA requirements for alternative fuels, creating new green jobs, and reducing the nation's dependence on foreign oil by replacing the whole barrel of petroleum-based fuels and products.	Ct-A. Lack of Acceptance and Awareness of Biofuels as a Viable Alternative Fuel Ct-B. Poorly Understood Role of Government versus the Role of Industry
Technical Accomplishments	Complete outreach efforts focused on celebrating specific Office contributions to new technologies, pathways, and directions as Office-supported projects achieve important milestones and deliverables.	Ct-A. Lack of Acceptance and Awareness of Biofuels as a Viable Alternative Fuel Ct-B. Poorly Understood Role of Government versus the Role of Industry
Benefits of Bioenergy and Bioproducts	Use various traditional and emerging media vehicles and outlets to increase awareness about the benefits of bioenergy and bioproducts.	
Environmental Benefits	Educate audiences about the environmental benefits of biomass as a viable alternative to fossil fuels, such as outreach efforts focused on the greenhouse gas emission reductions resulting from biomass-based alternative fuels.	Ct-A. Lack of Acceptance and Awareness of Biofuels as a Viable Alternative Fuel Ct-C. Inconsistent and Unpredictable Policy Landscape and Priorities are Inconsistent
Economic Benefits	Educate audiences about the economic benefits of a strong bioenergy industry, including the contribution to gross national product and keeping U.S. dollars within the United States.	Ct-A. Lack of Acceptance and Awareness of Biofuels as a Viable Alternative Fuel
Social Benefits	Educate audiences about the social benefits of a strong bioenergy industry, including the creation of new, green jobs.	Ct-A. Lack of Acceptance and Awareness of Biofuels as a Viable Alternative Fuel
Energy Security Benefits	Educate audiences about the energy security benefits of a strong bioenergy industry, including offsetting imported oil and resources expended securing availability of imported oil.	Ct-A. Lack of Acceptance and Awareness of Biofuels as a Viable Alternative Fuel
Use of New Communications Vehicles and Outlets	Implement new communications vehicles and outlets to disseminate clear and consistent, targeted Office messaging that will increase the Office's reach beyond current stakeholders, while maintaining costs.	
Communicate Difficult Concepts and Clarify Misconceptions	Strategically use new communications vehicles and outlets to create and distribute products that communicate difficult concepts and clarify misconceptions.	Ct-A. Lack of Acceptance and Awareness of Biofuels as a Viable Alternative Fuel Ct-B. Poorly Understood Role of Government versus the Role of Industry Ct-D. Increasing Information Clutter
Extend Reach of Traditional Media	Strategically use new communications vehicles and outlets to increase the distribution of traditional Office communications products.	Ct-A. Lack of Acceptance and Awareness of Biofuels as a Viable Alternative Fuel Ct-B. Poorly Understood Role of Government versus the Role of Industry Ct-D. Increasing Information Clutter
Reaching New Audiences	Strategically use new communications vehicles and outlets, in conjunction with traditional communication efforts, to reach new audiences and targeted demographics.	Ct-A. Lack of Acceptance and Awareness of Biofuels as a Viable Alternative Fuel Ct-B. Poorly Understood Role of Government versus the Role of Industry Ct-D. Increasing Information Clutter

Strategic Communications

Strategic Communications	2012		2013				2014				2015				2016				2017					
	Q1	Q2	Q3	Q4	Q1	Q2	Q3	Q4	Q1	Q2	Q3	Q4	Q1	Q2	Q3	Q4	Q1	Q2	Q3	Q4	Q1	Q2	Q3	Q4
1. Awareness of & Support for Office																								
1.1 Progress toward National Goals																								
1.1.1 Traditional Media Announcements																								
Release 25 announcements annually on Office accomplishments																								
1.1.2 Office Website																								
Increase unique website visitors by 5% annually to reach approximately 94,000 visitors in 2017																								
1.1.3 GovDelivery Listserv																								
Increase subscribers by 15% annually to reach approximately 19,000 subscribers in 2017																								
1.1.4 Biomass Annual Conference																								
Hold a Biomass conference annually																								
1.2 Technical Accomplishments																								
1.2.1 Press Releases/Publications/Technical Reports																								
Release at least 2 press releases annually on FOAs and other Office accomplishments																								
Create or update 15 publications, fact sheets, and technical reports annually																								
1.2.2 RDD&D Accomplishments Outreach																								
Perform outreach on the completion of modeled validation studies for the production of ethanol from corn stover through biochemical conversion at \$2.15/gallon																								
Perform outreach on the completion of modeled validation studies for the separation of ethanol from mixed alcohols derived from thermochemical conversion of woody biomass at \$2.05/gallon																								
Perform outreach on the completed identification of environmental criteria and the establishment of methods to integrate into biomass supply chains																								
Perform outreach related to the Office-supported IBR installed capacity target of 115 million gallons/year																								
1.2.3 Success Stories																								
Develop 1 success story per month																								
1.2.4 Presentations																								
Post all Office presentations from partner and industry events to the website within 2 weeks after the event																								
2. Benefits of Bioenergy/Bioproducts																								
2.1 Environmental Benefits																								
2.2 Economic Benefits																								
2.3 Social Benefits																								
2.4 Energy Security Benefits																								
2.1.1-2.4.1 Educational Outreach																								
Develop and execute 6 educational outreach campaigns annually																								
3. Use of New Communications Outlets & Vehicles																								
3.1 Communicate Difficult Concepts/Clarify Misconceptions																								
3.2 Extend Reach of Traditional Media																								

Project: Gantt draft mypp 2015
Date: Tue 5/20/14

Task Summary

Milestone Group By Summary

Strategic Communications



Figure 2-46: Strategic Communications Gantt chart

Section 3: Office Portfolio Management

This section describes how the U.S. Department of Energy's (DOE's) Bioenergy Technologies Office develops and manages its portfolio of research, development, demonstration, and deployment (RDD&D) activities. It identifies and relates different types of portfolio management activities, including portfolio decision making, analysis, and performance assessment.

Overview

The Bioenergy Technologies Office manages a diverse portfolio of technologies across the spectrum of applied RDD&D. Management of the Office's technology portfolio is a vital and demanding activity, made even more challenging by the fact that management of the portfolio must occur within the dynamic context of changing federal budgets and evolving administrative priorities.

To meet this challenge, the Office has developed a coordinated framework for managing its portfolio of RDD&D projects. The framework is based on systematically investigating, evaluating, and down-selecting the most promising opportunities across a diverse spectrum of emerging technologies and Technology Readiness Levels (see Table 3-1). This approach is intended to support a diverse technological base in applied research and development (R&D), while identifying the most promising targets for follow-on industrial-scale demonstration and deployment. The RDD&D pipeline is shown diagrammatically in Figure 3-1.

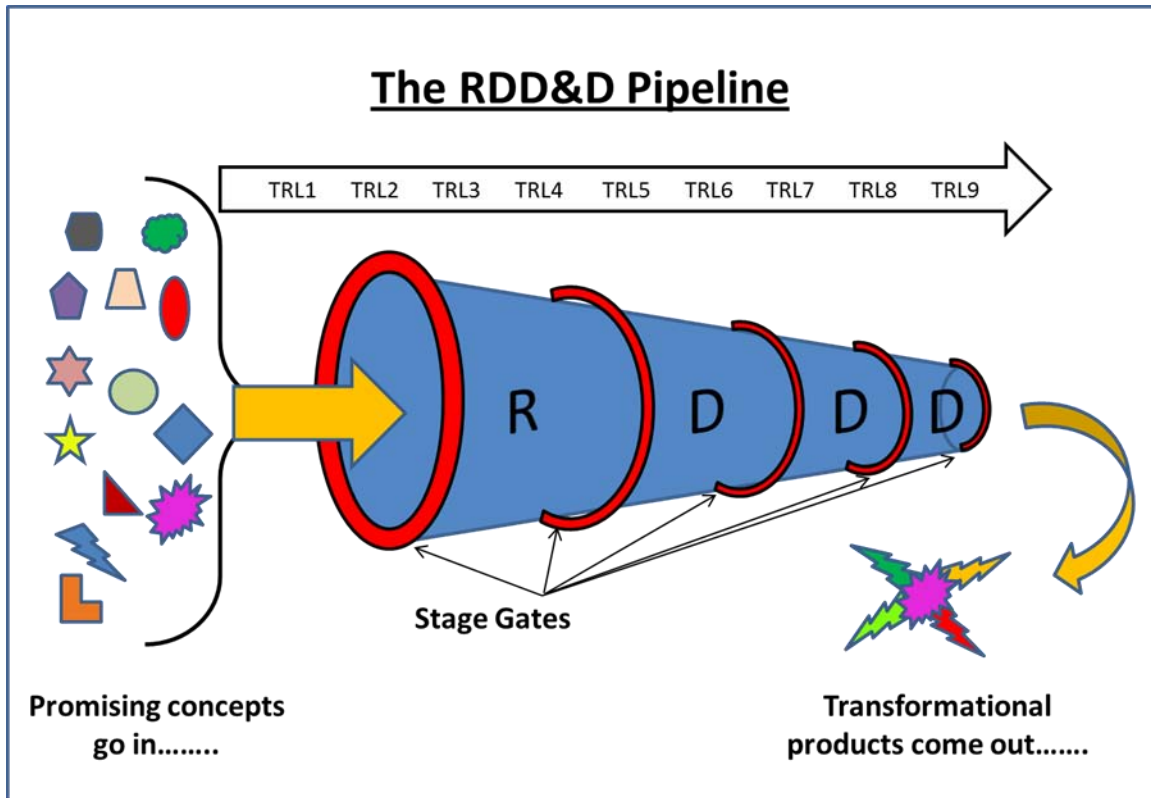

Figure 3-1: The RDD&D pipeline

Table 3-1: Technology Readiness Level (TRL) Definitions

TRL 1	<u>Basic Research</u> : Initial scientific research begins. Basic principles are observed. Focus is on fundamental understanding of a material or process. Principles are qualitatively postulated and observed. Supporting information includes published research or other references that identify the principles that underlie the material process.
TRL 2	<u>Applied Research</u> : Once basic principles are observed, initial practical applications can be identified. Applications are speculative, and there may be no proof or detailed analysis to support the assumptions. Potential of material or process to satisfy a technology need is confirmed. Supporting information includes publications or other references that outline the application being considered and that provide analysis to support the concept. The step up from TRL 1 to TRL 2 moves the ideas from basic to applied research. Most of the work is analytical or paper studies with the emphasis on understanding the science better. Experimental work is designed to corroborate the basic scientific observations made during TRL 1 work.
TRL 3	<u>Critical Function</u> : Applied research continues and early stage development begins. Includes studies and initial laboratory measurements to validate analytical predictions of separate elements of the technology. Analytical studies and laboratory-scale studies are designed to physically validate the predictions of separate elements of the technology. Examples include components that are not yet integrated. Supporting information includes results of laboratory tests performed to measure parameters of interest and comparison to analytical predictions for critical components. At TRL 3 experimental work is intended to verify that the concept works as expected. Components of the technology are validated, but there is no strong attempt to integrate the components into a complete system. Modeling and simulation may be used to complement physical experiments.
TRL 4	<u>Laboratory Testing/Validation of Alpha Prototype Component/Process</u> : Design, development, and lab testing of technological components are performed. Results provide evidence that applicable component/process performance targets may be attainable based on projected or modeled systems. The basic technological components are integrated to establish that the pieces will work together. This is relatively "low fidelity" compared with the eventual system. Examples include integration of ad hoc hardware in a laboratory and testing. Supporting information includes the results of the integrated experiments and estimates of how the experimental components and experimental test results differ from the expected system performance goals. TRL 4–6 represent the bridge from scientific research to engineering, from development to demonstration. TRL 4 is the first step in determining whether the individual components will work together as a system. The laboratory system will probably be a mix of on-hand equipment and a few special purpose components that may require special handling, calibration, or alignment to get them to function. The concept is there but the details of the unit process steps are not yet worked out. The goal of TRL 4 should be the narrowing of possible options in the complete system.
TRL 5	<u>Laboratory Testing of Integrated/Semi-Integrated System</u> : Component and/or process validation in relevant environment- (Beta prototype component level). The basic technological components are integrated so that the system configuration is similar to (matches) the final application in almost all respects. Supporting information includes results from the laboratory scale testing, analysis of the differences between the laboratory and eventual operating system/environment, and analysis of what the experimental results mean for the eventual operating system/environment. The major difference between TRL 4 and 5 is the increase in the fidelity of the system and environment to the actual application. The system tested is almost prototypical. Scientific risk should be retired at the end of TRL 5. Results presented should be statistically relevant.
TRL 6	<u>Prototype System Verified</u> : System/process prototype demonstration in an operational environment- (Beta prototype system level). Engineering-scale models or prototypes are tested in a relevant environment. This represents a major step up in a technology's demonstrated readiness. Examples include fabrication of the device on an engineering pilot line. Supporting information includes results from the engineering scale, testing and analysis of the differences between the engineering scale, prototypical system/environment, and analysis of what the experimental results mean for the eventual operating system/environment. TRL 6 begins true engineering development of the technology as an operational system. The major difference between TRL 5 and 6 is the step up from laboratory scale to engineering scale and the determination of scaling factors that will enable design of the final system. For PV cell or module manufacturing, the system that is referred to is the manufacturing system and not the cell or module. The engineering pilot scale demonstration should be capable of performing all the functions that will be required of a full manufacturing system. The operating environment for the testing should closely represent the actual operating environment. Refinement of the cost model is expected at this stage based on new learning from the pilot line. The goal while in TRL 6 is to reduce engineering risk. Results presented should be statistically relevant.
TRL 7	<u>Integrated Pilot System Demonstrated</u> : System/process prototype demonstration in an operational environment-(integrated pilot system level). This represents a major step up from TRL 6, requiring demonstration of an actual system prototype in a relevant environment. Supporting information includes results from the full-scale testing and analysis of the differences between the test environment, and analysis of what the experimental results mean for the eventual operating system/environment. Final design is virtually complete. The goal of this stage is to retire engineering and manufacturing risk. To credibly achieve this goal and exit TRL 7, scale is required as many significant engineering and manufacturing issues can surface during the transition between TRL 6 and 7.
TRL 8	<u>System Incorporated in Commercial Design</u> : Actual system/process completed and qualified through test and demonstration- (Pre-commercial demonstration). The technology has been proven to work in its final form and under expected conditions. In almost all cases, this TRL represents the end of true system development. Examples include full scale volume manufacturing of commercial end product. True manufacturing costs will be determined and deltas to models will need to be highlighted and plans developed to address them. Product performance delta to plan needs to be highlighted and plans to close the gap will need to be developed.
TRL 9	<u>System Proven and Ready for Full Commercial Deployment</u> : Actual system proven through successful operations in operating environment, and ready for full commercial deployment. The technology is in its final form and operated under the full range of operating conditions. Examples include steady state 24/7 manufacturing meeting cost, yield, and output targets. Emphasis shifts toward statistical process control.

This approach has several distinct advantages:

- It ensures that the Office will examine diverse feedstocks and conversion technologies for producing biofuels, biopower, and bioproducts
- It effectively links resources with the stages of technology readiness, from applied research through commercial deployment
- It successfully identifies gaps within the portfolio, as well as crucial linkages between the stages of RDD&D
- It is adequately flexible to accommodate new ideas and approaches, as well as various combinations of feedstock and process in real biorefineries
- It incorporates a stage-gate process, which guarantees a series of periodical technology readiness reviews to help inform the down-selection process.

3.1 Office Portfolio Management Process

The Bioenergy Technologies Office manages its portfolio based on the approach recommended under the Office of Energy Efficiency and Renewable Energy (EERE) Program Management Initiative,¹ complemented with processes derived from classical systems engineering for managing technically complex programs. The five major steps in the Office portfolio management process are shown in Figure 3-2 and are described on the following pages.

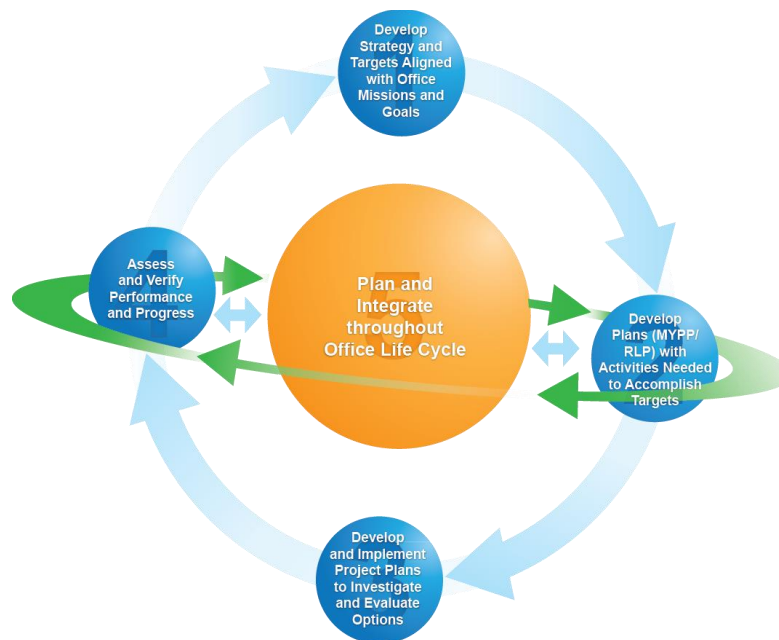

Figure 3-2: Office portfolio management process

¹ The EERE Program Management Initiative was launched in 2003 to address stakeholder expectations, the President's Management Agenda, DOE and EERE strategic plans, findings and recommendations by the National Academy of Public Administration, and the Government Performance and Results Act. Complete information is available at http://www1.eere.energy.gov/office_eere/bo_pmi.html.

Step 1: Develop Office Strategy and Targets Aligned with Office Mission and Goals.

Step 1 encompasses the process of developing the Office mission and goals (outlined in Section 1), both of which are developed from a combination of the Office's strategic goal hierarchy (see Figure 1-5) based on national goals, administrative and legislative priorities, and DOE and EERE strategic goals and priorities. The mission and goals are also developed in alignment with the goals of other federal agencies.

The Office design and logic (see Figure 1-7) detail how the mission and goals fit within the planning and budgetary framework of the Office. Combining the Office design and logic with an understanding of market needs and technical scenarios leads to the definition of Office targets that are consistent with government objectives. Targets are allocated to the Office elements responsible for managing and funding research related to the targets.

Portfolio decision making at the strategic level is based on three main criteria:

- Does the portfolio contain the correct elements across the RDD&D spectrum of activities to meet the technical and/or market targets required to achieve Office goals?
- Does the portfolio sponsor diverse technologies that can buy down the risk of producing competitively priced bioenergy?
- Does the portfolio support the establishment of the bioenergy industry in the United States?

Step 2: Develop Plans (MYPP/RLP) with Activities Needed to Accomplish Targets.

Step 2 guides how the Office develops its multi-year plan to outline the path to achieving the high-level Office technical and market targets defined in Step 1.

Each program has performance goals and barriers identified through internal evaluation and public-private collaborative meetings. To meet the Office's performance goals and address the associated barriers, each program develops a multi-year Resource-Loaded Plan (RLP) that identifies the strategic activities and associated resources to achieve respective targets. Program priorities to address the barriers are determined by balancing the needs and driving forces behind the emerging industry within the context of inherently governmental activities.

The program RLPs are then integrated into an Office-wide plan and evaluated for gaps and linkages. Gaps that are identified are addressed, while linkages between the technology areas are highlighted so that all parts of the supply chain are developed iteratively to comparable levels of maturity over time. The RLPs form the basis for activities described in the Multi-Year Program Plan (MYPP). The MYPP is designed to undergo review and be updated on a regular basis to incorporate technology advances, program learning, and changes in direction and priority.

Step 3: Develop and Implement Project Plans to Investigate and Evaluate Options.

Step 3 involves developing individual Project Management Plans (PMPs) that are aligned with the MYPP and the program technology area RLPs. The PMPs define the work selected to investigate and evaluate the chosen approaches for achieving the technical and market targets, as well as milestones in the MYPP.

Project development and analysis are used to define a portfolio of projects that, when combined, will most effectively achieve Office targets. Factors considered at the project level are similar to those considered at the Office level in Step 2 and include potential benefits, scope, cost, schedule, and risk. Also, like Step 2, this is an iterative process that weighs benefits against costs and risks; however, the emphasis stays on the specific projects under consideration and how they compare to each other, as well as their relevance to the Office. At the initiation of a project, a PMP is prepared to describe the entire project duration, with special attention to the activities planned for the year. PMPs are updated annually based on actual progress, results of interim stage-gate reviews, and updates to the Office MYPP.

Step 4: Assess and Verify Performance and Progress.

Step 4 involves a system of performance assessments held on multiple levels to monitor and evaluate performance and progress as the Office is implemented (described in detail in Section 3.2). The Office evaluates project performance on a quarterly basis against baseline schedule, scope, and cost provided in the PMP. The Office's program peer reviews and an overall Office peer review are conducted biennially to provide decision making on future funding and direction. Stage-gate and comprehensive project reviews are conducted at the individual project level to assess technical, economic, environmental, and market potential, as well as risk.

In large-scale demonstration projects and pioneer conversion facilities involving public-private partnerships, independent expert analysis, stage-gate decision making, and evaluation by the Office contribute to project risk assessments and go/no-go decisions.

Step 5: Plan and Integrate throughout the Office Life Cycle.

Step 5 includes cross-cutting technical and integration efforts designed to help program and project managers strengthen their management approaches to ensure a coordinated R&D effort, in addition to a well-integrated approach to technology demonstration and deployment. The diversity of technology options in each supply chain element and the distribution from applied science through development to demonstration and deployment lead to significant decision-making challenges.

3.1.1 Portfolio Analysis and Management

Portfolio analysis is carried out to determine the optimum portfolio of technologies and projects to achieve the Office's performance and market targets. Factors considered include the level of benefits expected, scope, cost, schedule, and risk to realizing the Office benefits. This is an

iterative process that weighs benefits against costs and risks, while taking into account the latest external information regarding market, technical status, and barriers. The process also incorporates the updated status of portfolio efforts based on verified, externally reviewed progress.

Portfolio management is not just a static annual activity, but rather is ongoing and synchronized to the budget cycle over several years. Each year, on a continuing basis, the Office reevaluates its goals and barriers, technical and market targets, and portfolio of technologies across the RDD&D spectrum; the Office then uses that information to assess its progress. Every year, there is a new set of decisions associated with populating the RDD&D pipeline with new R&D projects, assessing the performance of ongoing development and demonstration projects, down-selecting—via the stage-gate process—the most promising projects, and ceasing to fund those projects that are not performing or otherwise failing to address the Office’s goals.

The Bioenergy Technologies Office’s efforts to improve its portfolio management, analysis, and assessment efforts are supported by the Biomass Systems Integration Office. The focus of systems integration analysis is to understand the complex interactions between new technologies, system costs, environmental impacts, societal impacts, system tradeoffs, and penetration into existing systems and markets. The goals of integrated baseline management are to provide and maintain the links between the Office’s technical areas. Top-down technical baseline management evaluates the links between the Office’s mission and strategies, performance and goals, and milestones and decision points. Bottom-up programmatic baseline management evaluates the links of the scope, budget, and schedule of each individual project, as well as activities of the Office.

3.2 Performance Assessment

Performance assessment includes performance monitoring, as well as program and project evaluation. It provides the means to measure relevant outputs and outcomes that aid the Office in reevaluating its decisions, goals, and approaches, and tracks the actual progress being made. By design, the assessment processes provide input from other government agencies, stakeholders, and independent expert reviewers on effectiveness and progress towards Office mission and goals.

Table 3-2: Office and Project-Level Assessments that Support Decision Making

Assessment Type		Assessment Synopsis	Documentation
Performance Monitoring	External Monitoring	DOE's Annual Performance Target Tracking System	Annual Performance Target Reports
	Internal Monitoring	EERE's Corporate Planning System (CPS)	CPS Database/Website
		Project Monitoring with Quarterly Reports	Project Management Database
		Portfolio Monitoring with Technical Baseline Update	Biomass database and IBR performance monitoring reports
Office Evaluation	Peer Reviews	Conducted by independent experts outside of the Office portfolio to assess quality, productivity, and accomplishments, as well as relevance of Office success to EERE strategic and Office goals; and management ²	Public Summary Documents (including Office Response)
	General Office Evaluation Studies	Conducted by independent external experts to examine process, quantify outcomes or impacts, identify market needs and baselines, or quantify cost-benefit measures as appropriate ³	Public Reports and Documentation
Performance Monitoring and Office Evaluation	Technical Office Reviews	EERE Senior Management	EERE Internal
		Biomass R&D Technical Advisory Committee	Report to Congress (including Office Response)
	Technical Project Reviews	Stage-Gate Reviews conducted by DOE only for public/private demonstration projects, DOE plus independent industry, academia, or other government for precompetitive R&D projects	Internal Reports for Public-Private Demonstration Projects and Public Information for Precompetitive R&D Projects

Performance Monitoring

External Performance Monitoring

The Office of Management and Budget monitors Office performance against technical Annual Performance Targets. Each office is responsible for establishing and monitoring quarterly milestones, as well as meeting Annual Performance Targets established in Congressional Budget Requests.

Internal Performance Monitoring

The Office utilizes the Corporate Planning System (CPS) to help formulate, justify, manage, and execute Congressional Budget Requests. CPS also serves as a management tool to enable prospective spend planning, project data collection, and portfolio performance assessment. The system stores project-level management data, such as scope, schedule, and cost to track progress against technical milestones.

Standardized processes used to monitor and manage the performance of the projects (“agreements” in CPS) include the following:

- PMPs are developed to provide details of work planned throughout the entire project duration, as well as to establish measures for evaluating performance. The plans include

² U.S. Department of Energy: Energy Efficiency and Renewable Energy, *Peer Review Guide* (2004), Washington: Government Printing Office, <http://www1.eere.energy.gov/analysis/pdfs/2004peerreviewguide.pdf>.

³ U.S. Department of Energy: Energy Efficiency and Renewable Energy, *EERE Guide for Managing General Program Evaluation Studies: Getting the Information You Need* (2006), Washington: Government Printing Office, <http://www.seachangecop.org/sites/default/files/documents/2006%2002%20EERE%20-%20EERE%20Guide%20for%20Managing%20General%20Program.pdf>.

multi-year descriptions, milestones, schedules, and cost projections. The PMPs are updated annually.

- Quarterly project progress reports are submitted by the funded organizations, outlining financial and technical status, identifying problem areas, and highlighting achievements. The Office performs a quarterly assessment of project progress against the planned scope and schedule and financial performance against the cost projection and documents the assessment in a quarterly management report.
- The performance of major demonstration and deployment projects is also monitored through comprehensive annual project reviews and ongoing performance monitoring and analysis. The results of the reviews and performance monitoring are used for portfolio management and planning.

With nearly 350 projects in the Office portfolio, the project plans and progress information must be summarized and synthesized in order to evaluate overall Office performance in a meaningful way. The Office has implemented a systems engineering approach which integrates resource loaded technical plans across Office elements to assess portfolio balance and progress towards Office goals. The Office is also developing an integrated baseline, which links the technology-area-based project activities with resource-plan-based milestones. This illuminates gaps/issues in the current program portfolios and provides the foundation for data-driven decision making by Office management.

The Office uses additional systems engineering approaches, including interface management, independent performance verification, and robust information management tools to monitor overall progress toward achieving technical targets. The integrated baseline will be updated annually at a minimum, using project data and information. The updates will be used to monitor risks and identify critical technical gaps, cost overruns, and schedule slippages.

Office Evaluation

Peer Reviews

The Bioenergy Technologies Office uses an external peer review process to assess the performance of the programs, as well as of the Office as a whole. The Office implements the peer review process through a combination of program technology area peer reviews and an overall Office peer review, which are conducted at least biennially. The emphasis of the Office peer review is on the MYPP and the portfolio as a whole to determine whether or not it is balanced, organized, and performing appropriately. In contrast, the emphasis of the program technology area reviews is on the composition of projects that comprise the respective program portfolios and whether or not those projects are performing appropriately and contributing to program technology area goals.

The program peer reviews evaluate the RDD&D contributions of each program toward the overall Office goals, as well as the processes, organization, management, and effectiveness of the Bioenergy Technologies Office. The review is led by an independent steering committee that selects independent experts to review both the Office and program portfolios. The results of the review provide the feedback on the performance of the Office and its portfolio, identifying opportunities for improved Office management, as well as gaps or imbalances in funding that

need to be addressed. By addressing these gaps and imbalances, the Office will continue to stay focused on the highest priorities.

The program peer reviews are conducted prior to the Office review. Information and findings from the program peer reviews are incorporated into the comprehensive Office peer review process. The objectives of the program peer review meetings are as follows:

- Review and evaluate RDD&D accomplishments and future plans of projects in each program portfolio following the process guidelines of the EERE Peer Review Guide and incorporating the project evaluation criteria used in the Office Stage-Gate Management Process⁴
- Define and communicate Office strategic and performance goals applicable to the projects in that program portfolio
- Provide an opportunity for stakeholders and participants to learn about and provide feedback on the projects in that program portfolio to help shape future efforts so that the highest priority work is identified and addressed
- Foster interactions among industry, universities, and national laboratories conducting the RDD&D, thereby facilitating technology transfer.

Technical experts from industry and academia are selected as reviewers based on their experience in various aspects of biomass technologies under review, including project finance, public policy, and infrastructure. The reviewers score and provide qualitative comments on RDD&D based on the presentations given at the meeting and the background information provided. The reviewers also are asked to identify specific strengths, weaknesses, technology transfer opportunities, and recommendations for modifying project scope.

The Office analyzes all of the information gathered at the review and develops appropriate responses to the findings for each project. This information, including the Office response, is documented and published in a review report that is made available to the public through the Office website.⁵

General Office Evaluation Studies

The Bioenergy Technologies Office sponsors several activities and processes that are aligned with the program evaluation studies described in the EERE Guide for Managing General Program Evaluation Studies. The Office is conducting general program evaluations based on this guide, including:

- Needs/Market Assessment Evaluations
- Outcome Evaluations
- Impact Evaluations
- Cost-Benefit Evaluations.

Needs/Market Assessment Evaluations: In the past several years, the Bioenergy Technologies

⁴ “Stage-Gate Management in the Biomass Program: Revision 2,” Oak Ridge National Laboratory (2005), http://feedstockreview.ornl.gov/pdf/stage_gate_management_guide.pdf.

⁵ The most recent Program Review Portal website can be found at: <http://obpreview2011.govtools.us/>.

Office has held a number of workshops that have brought together stakeholders from federal and state government agencies, industry, academia, trade associations, and environmental organizations. These workshops identified the key needs and opportunities for biobased fuels, power, and products in the United States. Recent workshops have focused on feedstock supply, bioproducts, biopower, home heating oil, conversion technologies for advanced biofuels, and algae.

Outcome, Impact, and Cost/Benefit Evaluations: These types of evaluations are carried out by the EERE Office of Planning Budget and Analysis and were described previously in the Benefits Analysis portion of Section 2.5.

Performance Monitoring and Office Evaluation

The Bioenergy Technologies Office uses several forms of technical review to assess Office and program progress and promote improvement. These include the Biomass R&D Technical Advisory Committee Office reviews, EERE strategic office reviews, the project stage-gate management process, and comprehensive project reviews.

Technical Reviews

The Biomass Technical Advisory Committee reviews the joint USDA/DOE Biomass R&D portfolio annually and provides advice to the Secretary of Energy and Secretary of Agriculture concerning the technical focus and direction of the portfolios. Periodic reports are submitted to Congress by the Committee.⁶ Internally, DOE-EERE senior management holds periodic strategic office review meetings with the Bioenergy Technologies Office Director for various purposes, including preparation for Congressional budget submission and evaluation of strategic direction.

Technical Project Reviews

The Office also conducts project-level technical reviews. R&D projects are subject to the stage-gate management process and IBR D&D projects are subject to annual comprehensive project reviews.

Stage Gate Management Process

The stage-gate process, as depicted in Figure 3-3, is an approach for making disciplined decisions about R&D that lead to focused process and/or product development efforts.⁷ Specifically, the Office uses the stage-gate process to inform decisions regarding the following:

- Continuation of projects in the Office's technology portfolio
- Alignment of R&D project objectives with Office objectives and industry needs
- Distribution of Office funding across the spectrum of TRLs within the spectrum of RDD&D activities
- Guidance on project definition, including scope, quality, outputs, and integration
- Evaluation of projects for progress and alignment with the Office portfolio.

⁶ The most recent report, Annual Report to Congress on the Biomass Research and Development Initiative for 2006, can be accessed at http://www.biomassboard.gov/pdfs/biomass_initiative_report_to_congress_fy_2006.pdf.

⁷ "Stage-Gate Management in the Biomass Program: Revision 2," Oak Ridge National Laboratory.

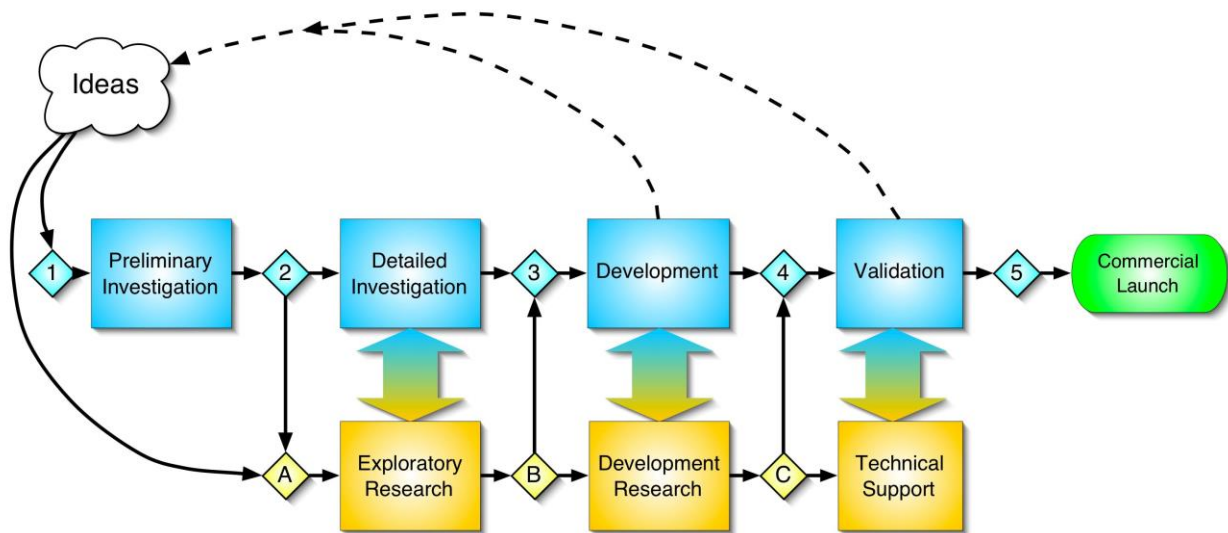

Figure 3-3: Bioenergy Technologies Office stage-gate process

Stage-Gate Reviews: Each stage is preceded by a decision point or gate that must be passed through before work on the next stage can begin. Gate reviews are conducted by a combination of internal management and outside experts. The purpose of each gate is twofold: first, the project must demonstrate that it met the objectives identified in the previous gate and stage plan; and second, that it satisfies the criteria for the current gate. A set of seven types of criteria are used to judge a project at each gate:

- Strategic Fit
- Market/Customer
- Technical Feasibility and Risks
- Competitive Advantage
- Legal/Regulatory Compliance
- Critical Success Factors and Show Stoppers
- Plan to Proceed.

Specific criteria are different for each gate and become more rigorous as the project moves along the development pathway.

The possible outcomes of this portion of the review could be pass, recycle, hold, or stop. Passing implies that the goals for the previous stage were met, and everything looks acceptable for authorization to proceed.

Recycling indicates that working longer in the current stage is justified—all goals have not been accomplished, but the project still has a high priority and promising potential.

Holding suspends a project because the need for it may have diminished or disappeared. There is an implication that the market demand could come back and the project could be resumed later.

Stopping a project might occur because the technology development is not progressing as it should, the market appears to have shifted permanently, the technology has become obsolete, or the economic advantage is no longer there. In this case, the best ideas from the project are salvaged, but the project is permanently halted.

The second half of the gate review takes place if the decision is made that the project “passes” the gate. The project leader must propose a project definition and preliminary plan for the next stage, including objectives, major milestones, high-level work breakdown structure, schedule, and resource requirements. The plan must be presented in sufficient detail for the reviewers to comment on the accomplishments necessary for the next stage, as well as to establish goals for completion of the next gate. Once the plan is accepted, the project can move to the next stage. Because the stakes get higher with each passing stage, the decision process becomes more complex and demanding. If the decision is made to “recycle” the project, the review panel will provide suggestions to the project leader on work that needs to be completed satisfactorily before the next gate review is held. In the case of a “hold” or “stop” decision, the plan to proceed is not needed.

An overview of the Bioenergy Technologies Office stage-gate process is available online.⁸ The stage-gate process is a key portfolio management tool because it integrates a number of challenging key decision areas, which include the following:

- Project selection and prioritization
- Resource allocation across projects
- Business strategy implementation.

The gates and gate reviews allow the Office to filter poor-performing or off-the-target projects and reallocate resources to the best projects and/or open the way for new projects to begin.

Comprehensive Project Reviews

The Office conducts annual comprehensive reviews on each of its major demonstration and deployment projects to monitor progress, identify key risks, and assess commercial viability. These in-depth reviews consider company structure and project management, technical performance, financial health, and commercial viability. Table 3-3 shows the key areas being assessed.

⁸ http://feedstockreview.ornl.gov/pdf/stage_gate_management_guide.pdf

Table 3-3: Comprehensive Project Review Evaluation Criteria

Evaluation Category	Specific Evaluation Criteria
COMPANY STRUCTURE AND PROJECT MANAGEMENT	
1A: Project Management	<ul style="list-style-type: none"> • Project team is aligned to manage completion of performance baseline (cost/schedule) • Risks identified and mitigated • Key expertise and staff retained • Intellectual property secured / licensed
1B: Performance Against Baseline Scope, Budget and Schedule	<ul style="list-style-type: none"> • Execution plans for operations are complete or appropriate for project stage • Performance baseline is well defined and complete • Earned value management metrics consistent with expectations, variances are addressed, plans for baseline are credible and achievable
1C: Risk Mitigation	<ul style="list-style-type: none"> • Risks adequately identified and risk mitigation plan maintained
TECHNICAL PERFORMANCE	
2A: Process Operations and Technical Targets	<ul style="list-style-type: none"> • Minimal new or untested technologies and process integrations • Technical performance appropriate for current stage and technical targets met • Environmental sustainability issues considered, measured, and addressed
2B: Feedstock Supply	<ul style="list-style-type: none"> • Feedstocks supply demonstrated at adequate scale to support commercial applications • Project feedstock(s) same as experimentally demonstrated and future commercial applications • Feedstock secured at reasonable cost to support long-term operations and feedstock supply logistics addressed • Environmental implications of feedstock production, logistics, and procurement assessed and addressed
FINANCIAL HEALTH AND MARKETING APPROVAL / COMMERCIALIZATION PLANS	
3A: Marketing Approval and Commercialization Plans	<ul style="list-style-type: none"> • Off-take agreements secured, production volumes aligned, and achievable path to market penetration defined • Marketing plan including fuel testing and approval coordinated with long term project plans • Commercialization plans developed
3B: Project Financing	<ul style="list-style-type: none"> • Adequate access to financing and cost-share secured • Post-construction working capital sources defined • Future financing needs supported by performance baseline and critical path • Financing risks adequately addressed in contingency plans
3C: Project Economics	<ul style="list-style-type: none"> • The projected <i>pro forma</i> for the envisioned first commercial plant incorporates achievable performance targets and cost goals adequate for financial returns and debt coverage required for future commercialization

Bibliography

- Aden, A., Ruth, M., et al. "Lignocellulosic Biomass to Ethanol Process Design and Economics Utilizing Co-Current Dilute Acid Prehydrolysis and Enzymatic Hydrolysis for Corn Stover," National Renewable Energy Laboratory, NREL/TP-510-32438 (2002), <http://www1.eere.energy.gov/biomass/pdfs/32438.pdf>.
- Advanced Ethanol Council. (2012). "Cellulosic Biofuels Industry Progress Report 2012-2013," http://ethanolrfa.3cdn.net/d9d44cd750f32071c6_h2m6vaik3.pdf.
- Bacovsky, D., Ludwiczek, N., Ognissanto, M., Wörgetter, M. (2013). "Status of Advanced Biofuels Demonstration Facilities in 2012: A Report to IEA Bioenergy Task 39," http://demoplants.bioenergy2020.eu/files/Demoplants_Report_Final.pdf.
- Baer, W.S., et al. (1976). "Analysis of Federally Funded Demonstration Projects: Executive Summary." RAND
- Biotechnology Industry Organization. *Biobased Chemicals and Products: A New Driver for Green Jobs*, March 10, 2010, <http://www.bio.org/articles/biobased-chemicals-and-products-new-driver-green-jobs>.
- Bozell, J.J. and Petersen, G.R. (2010). "Technology development for the production of biobased products from biorefinery carbohydrates – the US Department of Energy "Top 10" revisited." *Green Chemistry* 4(1). DOI:10.1039/B922014C.
- Chen, X., et al. (2012). "The impacts of deacetylation prior to dilute pretreatment on the bioethanol process." *Biotechnology for Biofuels* 5(8).
- Chundawat, S., Beckham, G., et al. (2011). "Deconstruction of Lignocellulosic Biomass to Fuels and Chemicals." *The Annual Review of Chemical and Biomolecular Engineering* 2(1). <http://www.annualreviews.org/doi/abs/10.1146/annurev-chembioeng-061010-114205>.
- Dale, V.H., Efroymsen, R.A., Kline, K.L., Langholtz, M.H., Leiby, P.N., Oladosu, G.A., Davis, M.R., Downing, M.E., Hilliard, M.R. (2013a). "Indicators for assessing socioeconomic sustainability of bioenergy systems: A short list of practical measures." *Ecological Indicators* 26(1).
- Davis et al. "Process Design and Economics for the Conversion of Lignocellulosic Biomass to Hydrocarbons: Dilute-Acid and Enzymatic Deconstruction of Biomass to Sugars and Biological Conversion of Sugars to Hydrocarbons," National Renewable Energy Laboratory, NREL/TP-5100-60223 (2013), <http://www.nrel.gov/docs/fy14osti/60223.pdf>.
- Davis, R., Fishman, D., Frank, E., et al. "Renewable Diesel from Algal Lipids: An Integrated Baseline for Cost, Emissions, and Resource Potential from a Harmonized Model," Argonne National Laboratory, ANL/ESDA/12-4 (2012), <http://greet.es.anl.gov/publication-algae-harmonization-2012>.
- Davis, R., Kinchin, C., Markham, J., Tan, E.C.D. et al. "Process Design and Economics for the Conversion of Algal Biomass to Biofuels," National Renewable Laboratory (2014).
- Efroymsen, R.A., Dale, V.H., Kline, K.L., McBride, A.C., Bielicki, J.M., Smith, R.L., Parish, E.S., Schweizer, P.E., Shaw, D.M. (2012). "Environmental indicators of biofuel sustainability: What about context?" *Environmental Management*, DOI 10.1007/s00267-012-9907-5.

http://web.ornl.gov/sci/ees/cbes/Publications/Efroymsonetal2012biofuelindicatorcontextEMfinal10%201007_s00267-012-9907-5.pdf

Executive Office of the President, *The President's Climate Action Plan*, June 2013,
<http://www.whitehouse.gov/sites/default/files/image/president27sclimateactionplan.pdf>.

Food and Agriculture Organization of the United Nations. "Bioenergy and Food Security,"
<http://www.fao.org/bioenergy/foodsecurity/befs/en/>.

Frost, J.W. (2005). "Redefining Chemical Manufacture—Replacing Petroleum with Plant-Derived Feedstocks." *Industrial Biotechnology*. 1, 23–24.

Gummerman, E., Marnay, C. (2004). "Learning and Cost Reductions for Generating Technologies in the National Energy Modeling System (NEMS)." LBNL-52559. Ernest Orlando Lawrence Berkeley National Laboratory, University of California Berkeley.

Harvey, B.C., Mylemans, H.A. (2013). "1-Hexene: A renewable C6 platform for full-performance jet and diesel fuels." *Green Chemistry* 2(1). DOI:10.1039/c3gc41554f.

Hess, J., Wright, C., et al. "Uniform-Format Solid Feedstock Supply System: A Commodity-Scale Design to Produce an Infrastructure-Compatible Bulk Solid from Lignocellulosic Biomass," Idaho National Laboratory, INL/EXT-08-14752 (2009), www.inl.gov/bioenergy/uni-form-feedstock.

Holladay J.E., White J.F., et al. "Top Value-Added Chemicals from Biomass: II. Results of Screening for Potential Candidates from Biorefinery Lignin." (2007). Richland, WA: Pacific Northwest National Laboratory.

Humbird, D., Davis, R., et al. "Process Design and Economics for Biochemical Conversion of Lignocellulosic Biomass to Ethanol: Dilute Acid Pretreatment and Enzymatic Hydrolysis of Corn Stover," NREL TP-510-47763 (2011), Golden, CO: National Renewable Energy Laboratory, <http://www.nrel.gov/biomass/pdfs/47764.pdf>.

Jones et al. "Process Design and Economics for the Conversion of Algal Biomass to Hydrocarbons: Whole Algae Hydrothermal Liquefaction and Upgrading," PNNL-23227 (2014), http://www.pnnl.gov/main/publications/external/technical_reports/PNNL-23227.pdf.

Jones, S. et al. "Process Design and Economics for the Conversion of Lignocellulosic Biomass to Hydrocarbon Fuels: Fast Pyrolysis and Hydrotreating Bio-Oil Pathway." PNNL-23053. (2013). Richland, WA: Pacific Northwest National Laboratory. http://www.pnnl.gov/main/publications/external/technical_reports/PNNL-23053.pdf.

Jones, S.B., Valkenburg, C.W., Walton, et al. "Production of Gasoline and Diesel from Biomass Via Fast Pyrolysis, Hydrotreating and Hydrocracking: A Design Case," PNNL-18284 (2009), Richland, WA: Pacific Northwest National Laboratory, http://www.pnl.gov/main/publications/external/technical_reports/pnnl-18284.pdf.

Jones, S.B., Zhu, Y., Snowden-Swan, L.J., Anderson, D.B., Hallen, R.T., Schmidt, A.J., Albrecht, K.A., Elliott, D.C. "Whole Algae Hydrothermal Liquefaction: 2014 State of Technology Pacific Northwest Laboratory, June 2014.

- Kenney et al. "Feedstock Supply System Design and Economics for Conversion of Lignocellulosic Biomass to Hydrocarbon Fuels-Conversion pathway: biological conversion of sugars to hydrocarbons." INL/EXT-13-30342 (2013), <https://inlportal.inl.gov/portal/server.pt?open=512&objID=421&parentname=CommunityPage&parentid=4&mode=2>.
- Koonin, S.E., Gopstein, A.M. "Accelerating the Pace of Energy Change." *Issues in Science and Technology*, Winter 2011.
- Lovins, A., et al, *Winning the Oil Endgame: Innovation for Profits, Jobs, and Security*, Rocky Mountain Institute (2004).
- Marton, A. (2011). "Research Spotlight: Getting off on the Right Foot – Innovative Projects." Independent Project Analysis Newsletter, 3(1).
- McBride A., Dale, V.H. Baskaran, L., Downing, M., Eaton, L., Efroymson, R.A., Garten, C., Kline, K.L., Jager, H., Mulholland, P., Parish, E., Schweizer, P., Storey, J. (2011). "Indicators to support environmental sustainability of bioenergy systems." *Ecological Indicators* 11(1).
- Merrow, E.W. (1989). "An Analysis of Cost Improvement in Chemical Process Technologies," RAND R-3357-DOE.
- Muth, D., Bryden, K.M. (2012). "An Integrated Model for Assessment of Sustainable Agricultural Residue Removal Limits for Bioenergy Systems." *Environmental Modelling and Software*. 39(1).
- Muth, D., Jacobson, J., Cafferty, K., Jeffers, R. "Define feedstock baseline scenario and assumptions for the \$80/DT target based on INL design report and feedstock logistics projects." ID#: 1.6.1.2.DL.4, 11.2.4.2.A.DL.2. Joule, WBS #: 1.6.1.2/11.2.4.2, Completion Date: 3/31/13, INL/EXT-14-31569.
- National Renewable Energy Laboratory, "What Is a Biorefinery?" (2009). <http://www.nrel.gov/biomass/biorefinery.html>.
- National Science Foundation, *The Roadway to Partial Petroleum Replacement with Biomass-Derived Fuels—A Report Along the Way*, (2010).
- Oak Ridge National Laboratory. (2005). "Stage-Gate Management in the Biomass Program: Revision 2," http://feedstockreview.ornl.gov/pdf/stage_gate_management_guide.pdf.
- Oak Ridge National Laboratory. (2013). *Transportation Energy Data Book, Edition 32*.
- Peters, M. S., Timmerhaus, K.D., West, R.E. "Plant Design and Economics for Chemical Engineers," (2003).
- Phillips, S., Aden, A., et al. "Thermochemical Ethanol via Indirect Gasification and Mixed Alcohol Synthesis of Lignocellulosic Biomass," National Renewable Energy Laboratory, NREL/TP-510-41168 (2007), <http://www.nrel.gov/docs/fy07osti/41168.pdf>.
- Renewable Fuels Association, *Battling for the Barrel: Ethanol Industry Outlook* (2013), <http://ethanolrfa.org/page/-/PDFs/RFA%202013%20Ethanol%20Industry%20Outlook.pdf?nocdn=1>.

- Searcy, E., Hess, J., Wright, C., Kenney, K., Jacobson, J. “State of Technology Assessment of Costs of Southern Pine for FY10 Gasification,” October 2010, INL/LTD-10-20306.
- Standlee, C. “Advanced Ethanol: Coming Online.” National Ethanol Conference. February 18, 2014. Orlando, FL.
- U.S. Congress, *Energy Independence and Security Act of 2007* (2007), Washington: Government Printing Office, <http://www.gpo.gov/fdsys/pkg/BILLS-110hr6enr/pdf/BILLS-110hr6enr.pdf>.
- U. S. Congress: Senate Energy and Natural Resources Committee, *Oversight Hearing on Oil Shale Development Efforts*, 109th Congress, 1st session, April 12, 2005.
- U.S. Department of Agriculture. “USDA Biofuels Strategic Production Report” (2010), http://www.usda.gov/documents/USDA_Biofuels_Report_6232010.pdf.
- U.S. Department of Commerce: Bureau of Economic Analysis, *National Income and Product Accounts: Table 1.1.9*, http://www.bea.gov/iTable/index_nipa.cfm.
- U.S. Department of Energy: Alternative Fuels Data Center, *Global Ethanol Production* (2013), <http://www.afdc.energy.gov/data/10331>.
- U.S. Department of Energy. *Annual Energy Outlook 2007: Biofuels in the U.S. Transportation Sector, Table 11* (2007), Washington: Government Printing Office. <http://www.eia.doe.gov/oiaf/analysispaper/biomass.html>.
- U.S. Department of Energy, *Annual Energy Outlook 2009: Table 112* (2009), Washington: Government Printing Office, http://www.eia.doe.gov/oiaf/archive/aeo09/supplement/suptab_112.xls.
- U.S. Department of Energy, *Annual Energy Outlook 2012: High Oil Price Case, Table 70* (2012), Washington: Government Printing Office.
- U.S. Department of Energy, *Annual Energy Outlook 2012: Table 131* (2012), Washington: Government Printing Office, http://www.eia.gov/oiaf/aeo/supplement/suptab_131.xlsx.
- U.S. Department of Energy, *Annual Energy Outlook 2012 with Projections to 2035* (2012), Washington: Government Printing Office, DOE/EIA-0383.
- U.S. Department of Energy, *Annual Energy Outlook 2013 with Projections to 2040*, http://www.eia.gov/forecasts/archive/aeo13/source_oil_all.cfm#tighthoil.
- U.S. Department of Energy, *Annual Energy Outlook 2014 with Projections to 2040*.
- U.S. Department of Energy. “Bioenergy Knowledge Discovery Framework,” <http://www.bioenergykdf.net>.
- U.S. Department of Energy: Bioenergy Technologies Office, *Multi-Year Program Plan 2007–2012* (2005), Washington: Government Printing Office.
- U.S. Department of Energy: Bioenergy Technologies Office, *2013 Peer Review Report* (2014), Washington: Government Printing Office, http://www1.eere.energy.gov/bioenergy/pdfs/2013_peer_review.pdf.

- U.S. Department of Energy. *Conversion Technologies for Advanced Biofuels Workshop Report* (2013), Washington, D.C.: Government Printing Office. Manuscript in preparation.
- U.S. Department of Energy. DOE Order 413.3B, Program and Project Management for the Acquisition of Capital Assets, <https://www.directives.doe.gov/directives-documents/0413.3-BOrder-b/view>.
- U.S. Department of Energy: Energy Efficiency and Renewable Energy, *EERE Guide for Managing General Program Evaluation Studies: Getting the Information You Need* (2006), Washington: Government Printing Office, http://energy.gov/sites/prod/files/2013/11/f5/evaluation_mgmt_guide_final_2006_0.pdf.
- U.S. Department of Energy: Energy Efficiency and Renewable Energy, *Peer Review Guide* (2004), Washington: Government Printing Office, <http://www1.eere.energy.gov/analysis/pdfs/2004peerreviewguide.pdf>.
- U.S. Department of Energy, *Intermediate Ethanol Blends* (2013), http://www1.eere.energy.gov/vehiclesandfuels/technologies/fuels/ethanol_blends.html.
- U.S. Department of Energy, *International Energy Outlook 2013* (2013), Washington: Government Printing Office, DOE/EIA-0484.
- U.S. Department of Energy, *Monthly Energy Review* (December 2013), Washington: Government Printing Office, DOE/EIA-0035.
- U.S. Department of Energy, *Most states have Renewable Portfolio Standards*, February 3, 2012.
- U.S. Department of Energy. *National Algal Biofuels Technology Roadmap* (2010), Washington: Government Printing Office, http://www1.eere.energy.gov/biomass/pdfs/algal_biofuels_roadmap.pdf.
- U.S. Department of Energy, *Top Value Added Chemicals from Biomass: Volume I—Results of Screening for Potential Candidates from Sugars and Synthesis Gas* (2004).
- U.S. Department of Energy. (2011). *U.S. Billion-Ton Update: Biomass Supply for a Bioenergy and Bioproducts Industry*. R.D. Perlack and B.J. Stokes (Leads), ORNL/TM-2011/224. Oak Ridge National Laboratory, Oak Ridge, TN. http://www1.eere.energy.gov/biomass/pdfs/billion_ton_update.pdf.
- U.S. Energy Information Administration, *Annual Energy Review* (2014), <http://www.eia.gov/totalenergy/data/annual/>.
- U.S. Energy Information Administration, *Direct Federal Financial Interventions and Subsidies in Energy in Fiscal Year 2010*, (July 2011), <http://www.eia.gov/analysis/requests/subsidy/pdf/subsidy.pdf>.
- Vimmerstedt, L. J., Bush, B. W. “Effects of Deployment Investment on the Growth of the Biofuels Industry” (2013), NREL/TP-6A20-60802, Golden, CO: National Renewable Energy Laboratory, <http://www.nrel.gov/docs/fy14osti/60802.pdf>.
- Werpy, T.A., Holladay, J.E., et al. “Top Value-Added Chemicals from Biomass: I. Results of Screening for Potential Candidates from Sugars and Synthesis Gas.” PNNL-14808 (2004), Richland, WA: Pacific Northwest National Laboratory.







WIPO/PCT WO2012/166267 A2 Patent: Method to Convert Fermentation Mixture into Fuels. (2012).

World Energy Council, “Survey of Energy Resources” (2010),
http://www.worldenergy.org/documents/ser_2010_report_1.pdf.

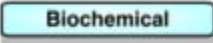
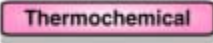
Appendix A: Technology Pathway Structure

High-level block flow diagrams for each biorefinery pathway are presented in Figures A-1 through A-5. These diagrams show the current process (if it exists today) and current products, including fuels, chemicals, and power; options for improvements; and associated new products. *These diagrams are not intended to be all inclusive; many other viable processing options are possible.* These diagrams do not display options for pathways that are considered mature commercial technology.

The blocks and paths on the diagrams are coded as follows:

-  – Feedstocks R&D
-  – Biochemical Conversion R&D
-  – Thermochemical Conversion R&D
-  Bold blocks – Highest priorities
-  Dash blocks – Medium and low priorities
-  – New routes to biofuels, with heavy lines indicating the highest-priority routes
-  – Potential new enabling non-fuel products
-  OR → – Existing processing steps in current biorefineries
-  – Indicates that an “option” exists on how to process the stream. The options must be evaluated and compared against each other to identify the best overall pathway configuration. For pathways representing existing industry segments, the options include the status quo. The options analysis may compare options that would take the full stream or fractions of the full stream. The ability to add and evaluate options within a pathway results in a flexible framework for considering innovative new ideas in the future.

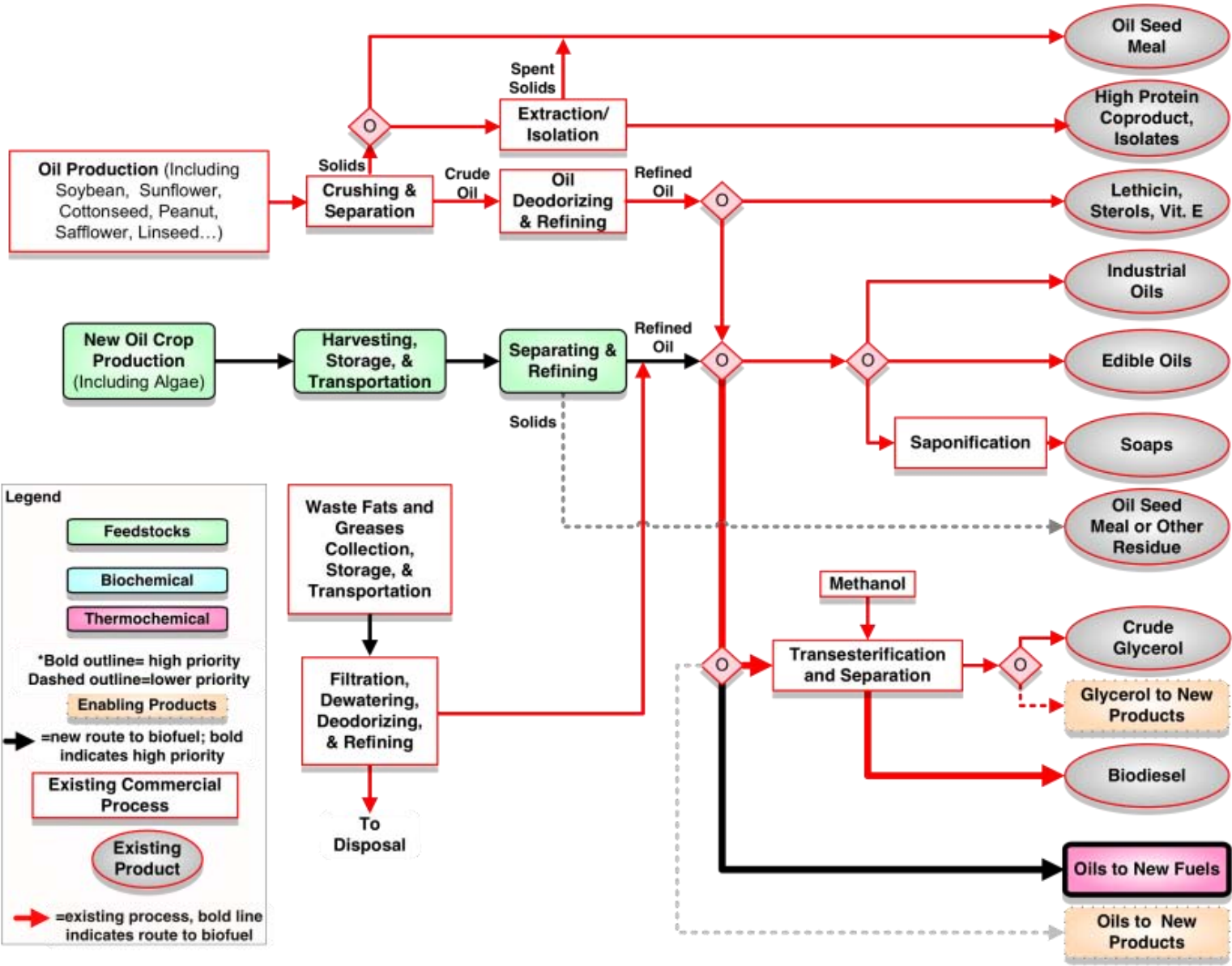

Figure A-1: Natural oils pathway

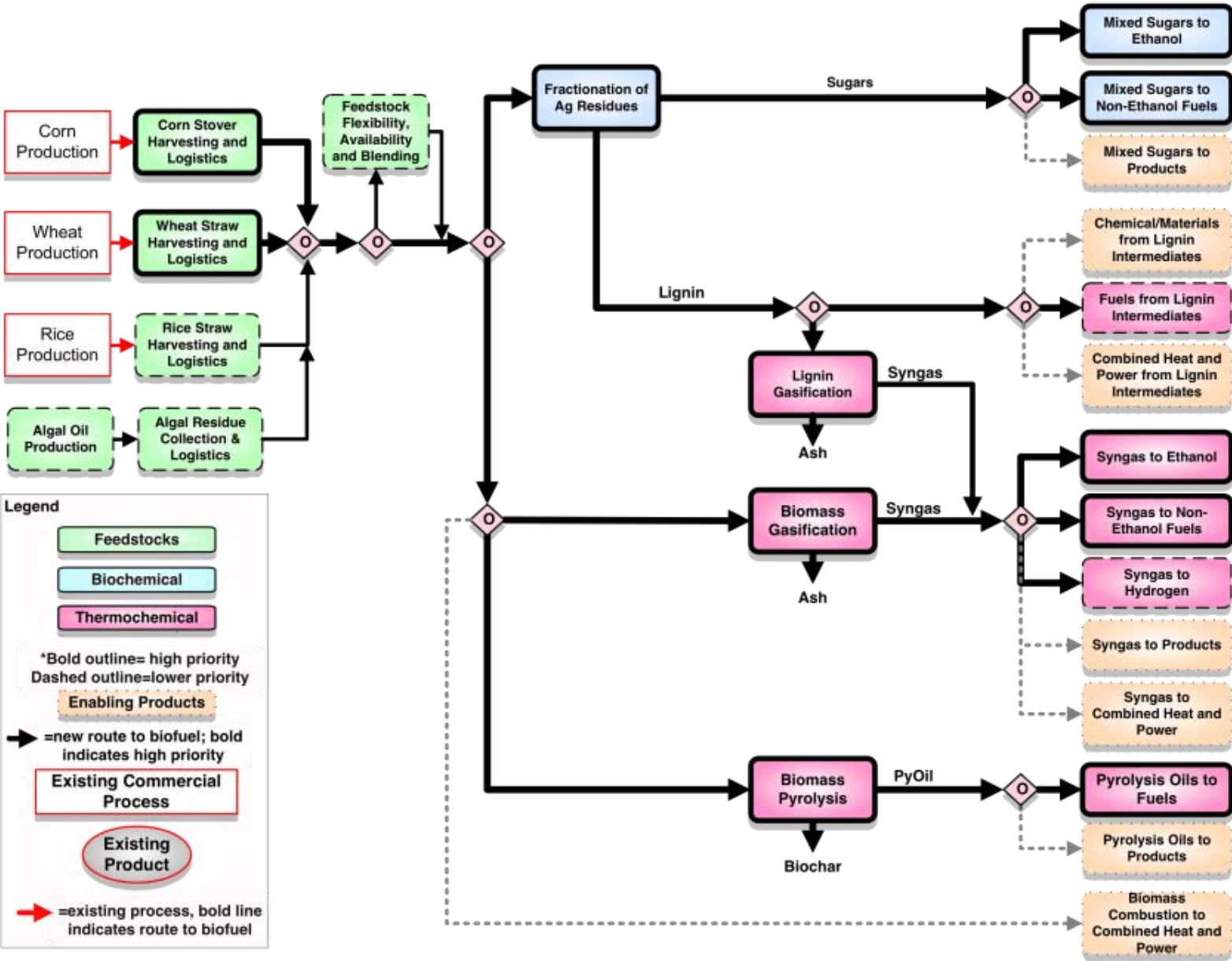

Figure A-2: Agricultural residues pathway

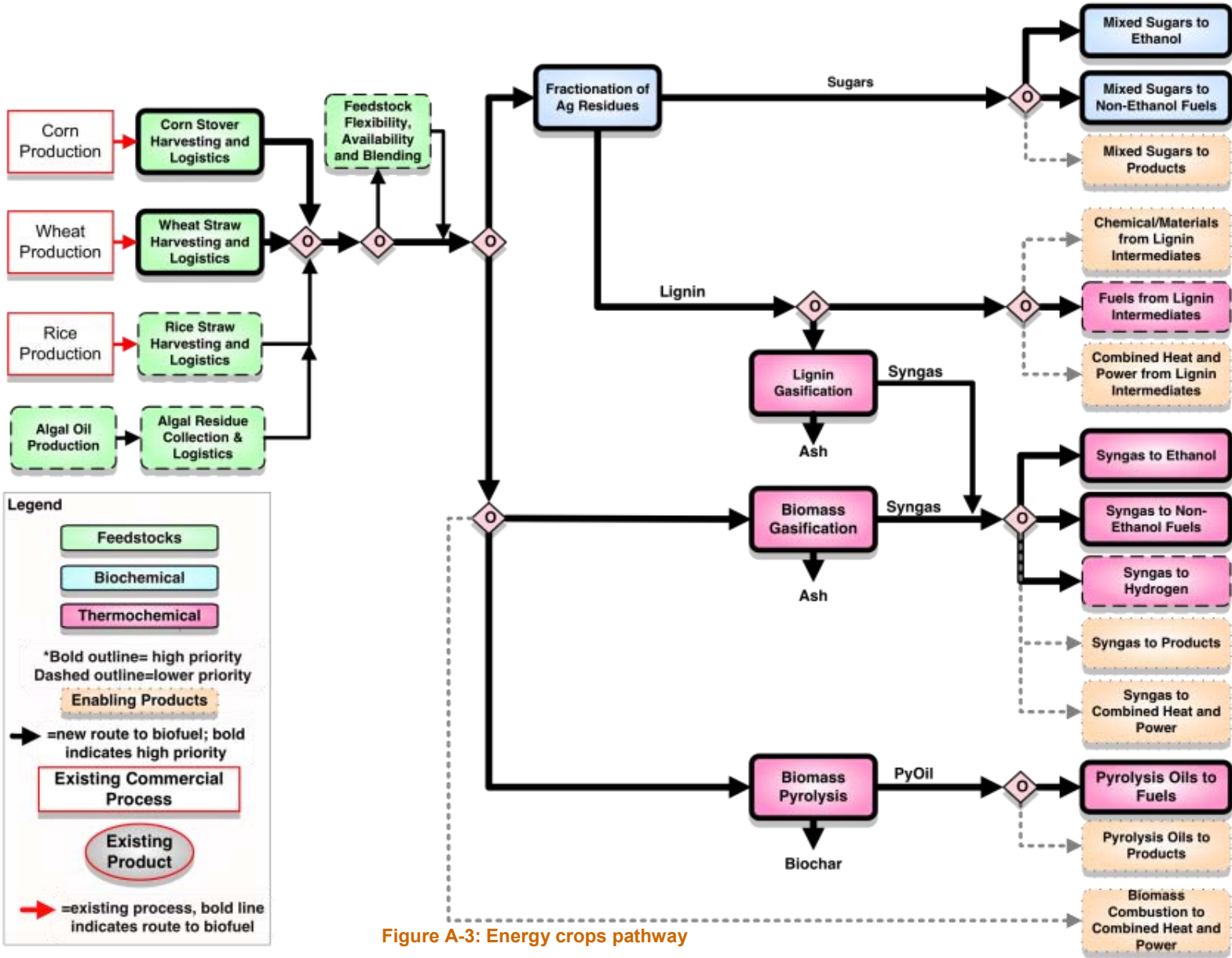

Figure A-3: Energy crops pathway

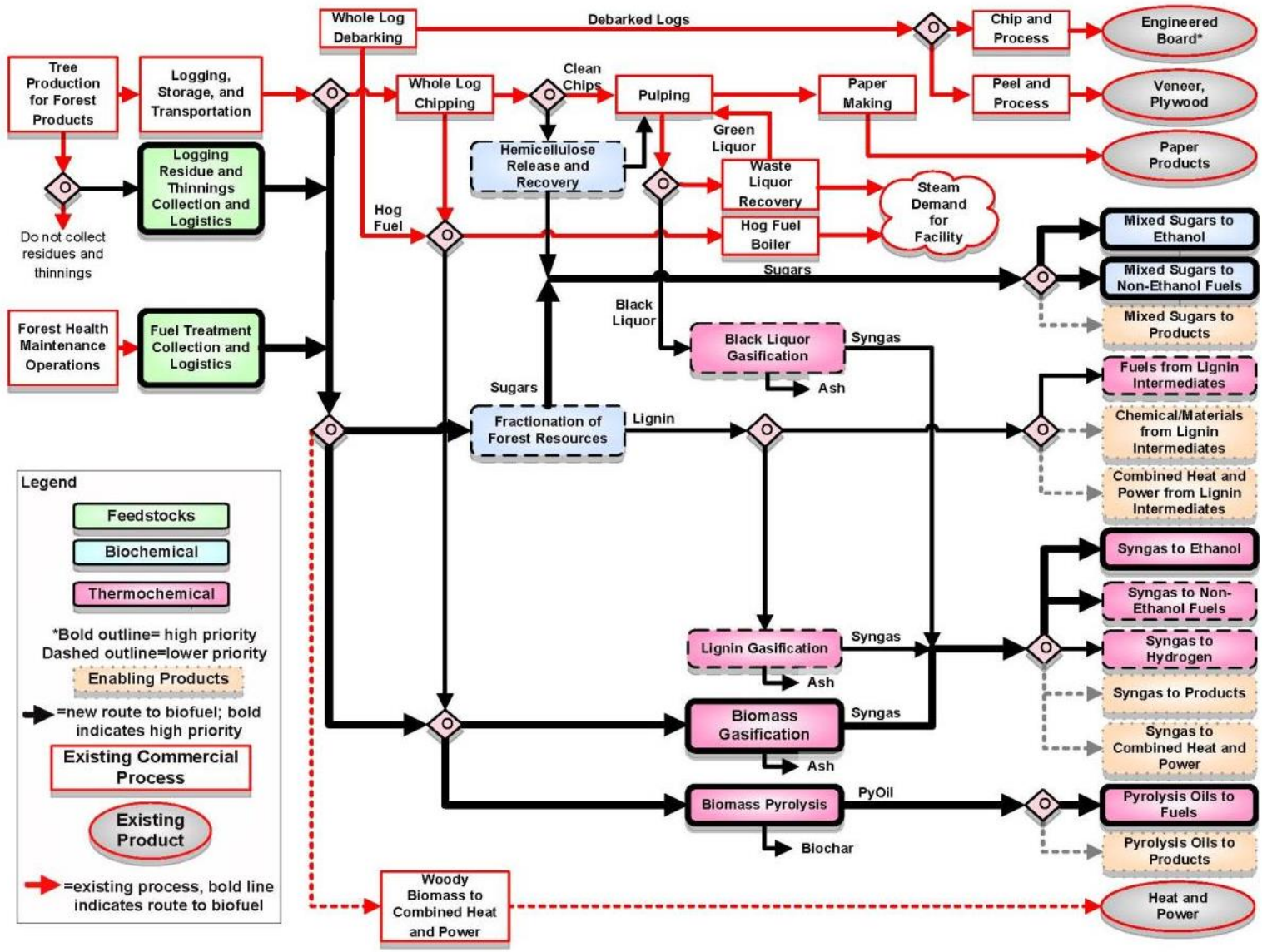

Figure A-4: Forest resources pathway

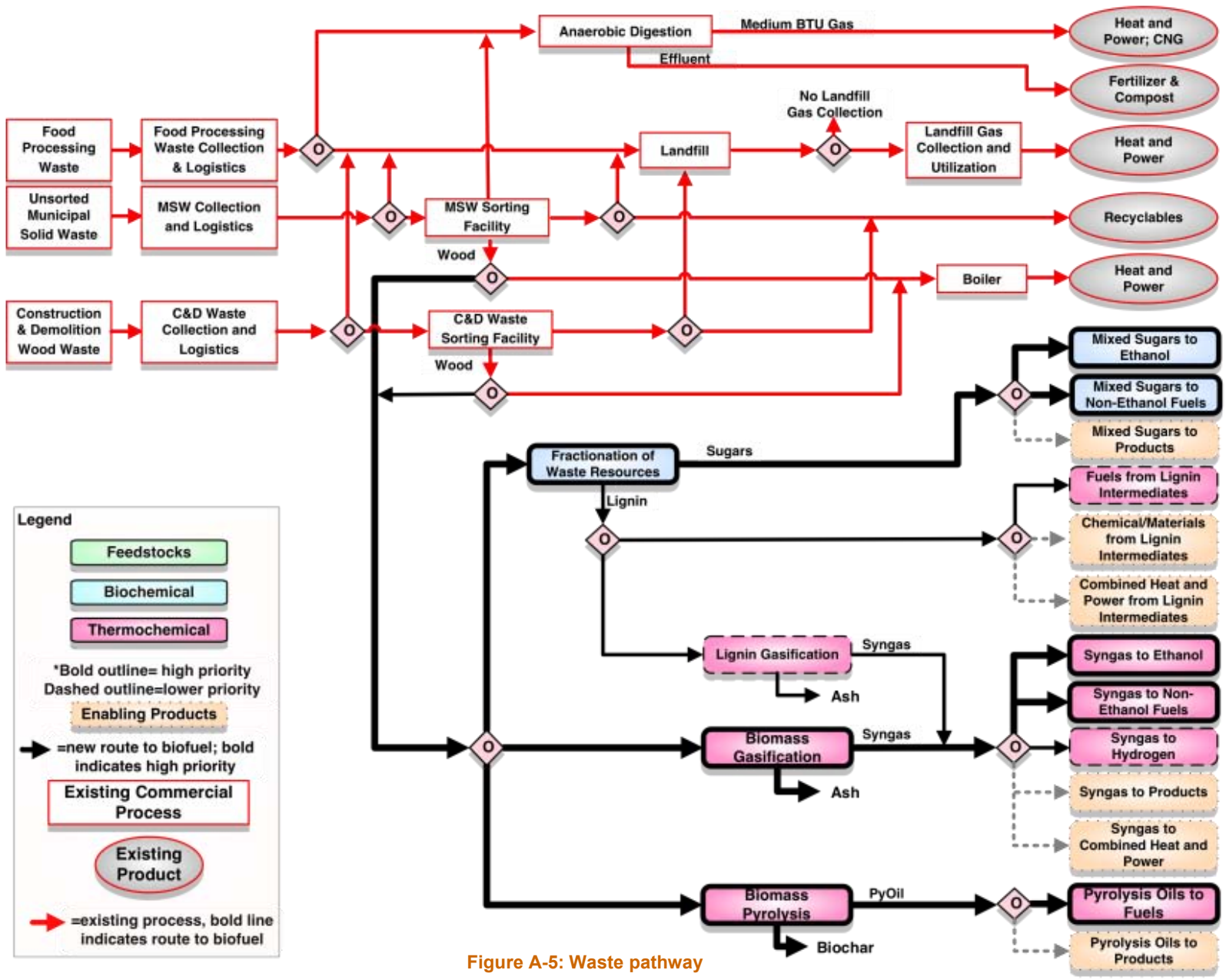

Figure A-5: Waste pathway

Appendix B: Technical Projection Tables

Table B-1: Biomass Volume and Price Projections through 2030 (minus allocations for losses, chemicals, and pellets)

Feedstock Category	Feedstock Resource	Feedstock Available for Cellulosic Fuel Production (MM Dry Tons/Year)							
		SOT	Projection						
		2013	2014	2015	2016	2017	2018	2022	2030
Agricultural Residues	Corn Stover	70.7	83.2	106.7	131.8	138.1	150.7	154.1	172.5
	Wheat Straw	11.2	12.9	13.9	15.9	17.1	18.7	13.9	35.6
Energy Crops	Herbaceous Energy Crops	-	0.5	1.9	3.3	6.4	9.2	10.7	50.2
	Woody Energy Crops	-	-	-	-	-	0.2	5.0	22.9
Forest Residues	Pulpwood	0.8	1.2	1.6	2.1	2.7	3.3	1.7	31.4
	Logging Residues and Fuel Treatments	60.6	56.6	55.1	34.0	50.2	50.5	67.1	60.9
	Other Forestland Removals	0.6	0.8	0.4	0.6	1.3	1.2	0.9	2.9
	Urban and Mill Wood Wastes	32.3	31.3	31.0	27.0	29.9	29.7	31.0	33.8
Totals (MM Dry Tons/Year)		176.1	186.5	210.6	214.7	245.7	263.4	284.5	410.2
Average Price to Reactor (2011\$/Dry Ton)		102.12	101.45	92.36	86.72	80.00	80.00	80.00	80.00

Table B-2: Terrestrial Feedstock Supply and Logistics Costs to Supply Feedstock to a Pyrolysis Conversion Process

Processing Area Cost Contribution (\$2011)		2013 SOT	2014 Projection	2015 Projection	2016 Projection	2017 Projection	2018 Projection	2019 Projection
Delivered Feedstock Type		Pine	Pine	Blend	Blend	Blend	Blend	Blend
Total Delivered Cost	\$/dry ton	\$102.12	\$101.45	\$92.36	\$86.72	\$80.00	\$80.00	\$80.00
Grower Payment	\$/dry ton	\$25.00	\$25.00	\$24.43	\$23.45	\$21.90	\$21.90	\$21.90
Total Feedstock Logistics	\$/dry ton	\$77.12	\$76.45	\$67.93	\$63.27	\$58.10	\$58.10	\$58.10
Harvest and Collection	\$/dry ton	\$22.24	\$22.24	\$16.68	\$14.46	\$10.47	\$10.47	\$10.47
Landing Preprocessing	\$/dry ton	\$12.17	\$12.17	\$11.37	\$11.02	\$10.24	\$10.24	\$10.24
Transportation and Handling	\$/dry ton	\$14.84	\$14.84	\$12.47	\$8.48	\$7.52	\$7.52	\$7.52
In-Plant Receiving and Processing	\$/dry ton	\$27.87	\$27.20	\$27.41	\$29.31	\$29.87	\$29.87	\$29.87
Total Delivered Cost	\$/gal total fuel	\$1.16	\$1.15	\$1.05	\$0.99	\$0.91	\$0.91	\$0.91
Grower Payment	\$/gal total fuel	\$0.28	\$0.28	\$0.28	\$0.27	\$0.25	\$0.25	\$0.25
Total Feedstock Logistics	\$/gal total fuel	\$0.88	\$0.87	\$0.77	\$0.72	\$0.66	\$0.66	\$0.66
Harvest and Collection	\$/gal total fuel	\$0.25	\$0.25	\$0.19	\$0.16	\$0.12	\$0.12	\$0.12
Landing Preprocessing	\$/gal total fuel	\$0.14	\$0.14	\$0.13	\$0.13	\$0.12	\$0.12	\$0.12
Transportation and Handling	\$/gal total fuel	\$0.17	\$0.17	\$0.14	\$0.10	\$0.09	\$0.09	\$0.09
In-Plant Receiving and Processing	\$/gal total fuel	\$0.32	\$0.31	\$0.31	\$0.33	\$0.34	\$0.34	\$0.34
Yield	gallons total fuel / dry ton	88	88	88	88	88	88	88

Table B-3: Unit Operation Cost Contribution Estimates (2011\$) and Technical Projections for Algal Lipid Upgrading

Processing Area Cost Contributions & Key Technical Parameters	Metric	2014 SOT [†]		2022 Projected [†]
Diesel selling price	\$/gal diesel	\$15.57		\$4.49
Conversion Contribution, Diesel	\$/GGE	\$2.36		\$1.18
Performance Goal	\$/GGE	-		\$3
Diesel Production	mm gallons/yr	34		54
Production Co-Product Naphtha	mm gallons/yr	11		11
Diesel Yield (AFDW algae basis)	gal/US ton algae	77		122
Naphtha Yield (AFDW algae basis)	gal/us ton algae	25		25
Natural Gas Usage (AFDW algae basis)	scf/U.S. ton algae	2,805		2,946
Feedstock				
Total Cost Contribution	\$/gge fuel	\$13.21		\$3.31
Feedstock Cost (AFDW algae basis)	\$/U.S. ton algae	\$1,092		\$430.00
AHTL				
Total Cost Contribution	\$/gge fuel	\$1.78		\$0.62
Capital Cost Contribution	\$/gge fuel	\$1.36		\$0.46
Operating Cost Contribution	\$/gge fuel	\$0.42		\$0.16
AHTL Oil Yield (dry)	lb /lb algae	0.40		0.59
AHTL Oil Hydrotreating to Finished Fuels				
Total Cost Contribution	\$/gge fuel	\$0.34		\$0.35
Capital Cost Contribution	\$/gge fuel	\$0.22		\$0.14
Operating Cost Contribution	\$/gge fuel	\$0.12		\$0.21
Mass Yield on dry AHTL Oil	lb/lb AHTL oil	0.86		0.83
Catalytic Hydrothermal Gasification of AHTL Aqueous Phase				
Total Cost Contribution	\$/gge fuel	\$0.74		\$0.63
Capital Cost Contribution	\$/gge fuel	\$0.39		\$0.37
Operating Cost Contribution	\$/gge fuel	\$0.35		\$0.26
Balance of Plant				
Total Cost Contribution	\$/gge fuel	(\$0.50)		(\$0.42)
Capital Cost Contribution	\$/gge fuel	\$0.24		\$0.18
Operating Cost Contribution	\$/gge fuel	\$0.24		\$0.04
Naphtha Credit (\$3.25/gal)	\$/gge fuel	(\$0.99)		(\$0.63)
Models: Case References		TO1014-SOT		030114P

* Jones et al. "Process Design and Economics for the Conversion of Algal Biomass to Hydrocarbons: Whole Algae Hydrothermal Liquefaction and Upgrading" Pacific Northwest National Laboratory Report 23227 (2014)

† S.B.Jones, Y. Zhu, L.J. Snowden-Swan, D.B. Anderson, R.T. Hallen, A.J. Schmidt, K.A. Albrecht, D.C. Elliott, "Whole Algae Hydrothermal Liquefaction: 2014 State of Technology Pacific Northwest Laboratory, June 2014

Table B-4: Unit Operation Cost Contribution Estimates (2011\$) and Technical Projections for Whole Algae Hydrothermal Liquefaction and Upgrading to Diesel

Processing Area Cost Contributions & Key Technical Parameters	Metric	2014 SOT [†]		2022 Projected [†]
Diesel selling price	\$/gal diesel	\$15.57		\$4.49
Conversion Contribution, Diesel	\$/GGE	\$2.36		\$1.18
Performance Goal	\$/GGE	-		\$3
Diesel Production	mm gallons/yr	34		54
Production Co-Product Naphtha	mm gallons/yr	11		11
Diesel Yield (AFDW algae basis)	gal/US ton algae	77		122
Naphtha Yield (AFDW algae basis)	gal/us ton algae	25		25
Natural Gas Usage (AFDW algae basis)	scf/U.S. ton algae	2,805		2,946
Feedstock				
Total Cost Contribution	\$/gge fuel	\$13.21		\$3.31
Feedstock Cost (AFDW algae basis)	\$/U.S. ton algae	\$1,092		\$430.00
AHTL				
Total Cost Contribution	\$/gge fuel	\$1.78		\$0.62
Capital Cost Contribution	\$/gge fuel	\$1.36		\$0.46
Operating Cost Contribution	\$/gge fuel	\$0.42		\$0.16
AHTL Oil Yield (dry)	lb /lb algae	0.40		0.59
AHTL Oil Hydrotreating to Finished Fuels				
Total Cost Contribution	\$/gge fuel	\$0.34		\$0.35
Capital Cost Contribution	\$/gge fuel	\$0.22		\$0.14
Operating Cost Contribution	\$/gge fuel	\$0.12		\$0.21
Mass Yield on dry AHTL Oil	lb/lb AHTL oil	0.86		0.83
Catalytic Hydrothermal Gasification of AHTL Aqueous Phase				
Total Cost Contribution	\$/gge fuel	\$0.74		\$0.63
Capital Cost Contribution	\$/gge fuel	\$0.39		\$0.37
Operating Cost Contribution	\$/gge fuel	\$0.35		\$0.26
Balance of Plant				
Total Cost Contribution	\$/gge fuel	(\$0.50)		(\$0.42)
Capital Cost Contribution	\$/gge fuel	\$0.24		\$0.18
Operating Cost Contribution	\$/gge fuel	\$0.24		\$0.04
Naphtha Credit (\$3.25/gal)	\$/gge fuel	(\$0.99)		(\$0.63)
Models: Case References		TO1014-SOT		030114P

* Jones et al. "Process Design and Economics for the Conversion of Algal Biomass to Hydrocarbons: Whole Algae Hydrothermal Liquefaction and Upgrading" Pacific Northwest National Laboratory Report 23227 (2014)

† S.B.Jones, Y. Zhu, L.J. Snowden-Swan, D.B. Anderson, R.T. Hallen, A.J. Schmidt, K.A. Albrecht, D.C. Elliott, "Whole Algae Hydrothermal Liquefaction: 2014 State of Technology Pacific Northwest Laboratory, June 2014

Table B-5: Unit Operation Cost Contribution Estimates (2011\$) and Technical Projections for Thermochemical Conversion to Gasoline and Diesel Baseline Process Concept⁵

(Process Concept: Woody Feedstock, Fast Pyrolysis, Bio-Oil Upgrading, Fuel Finishing)*

Processing Area Cost Contributions & Key Technical Parameters	Metric	2009 SOT	2010 SOT	2011 SOT	2012 SOT	2013 SOT	2014 Projection	2015 Projection*	2016 Projection*	2017 Projection*
Conversion Contribution	\$/gal gasoline blendstock	\$12.40	\$9.22	\$7.32	\$6.20	\$4.51	\$4.02	\$3.63	\$2.96	\$2.44
	\$/gal diesel blendstock	\$13.03	\$9.69	\$7.69	\$6.52	\$5.01	\$4.46	\$4.03	\$3.29	\$2.70
Conversion Contribution, Combined Blendstocks	\$/GGE	\$12.02	\$8.94	\$7.10	\$6.02	\$4.59	\$4.09	\$3.69	\$3.01	\$2.47
Programmatic Target	\$/GGE	\$3	\$3	\$3	\$3	\$3	\$3	\$3	\$3	\$3
Combined Fuel Selling Price	\$/GGE	\$13.40	\$10.27	\$8.26	\$7.04	\$5.77	\$5.26	\$4.75	\$4.01	\$3.39
Production Gasoline Blendstock	mm gallons/yr	30	30	30	30	29	29	29	29	29
Production Diesel Blendstock	mm gallons/yr	23	23	23	23	32	32	32	32	32
Yield Combined Blendstocks	GGE/dry U.S. ton	78	78	78	78	87	87	87	87	87
Yield Combined Blendstocks	mmBTU/dry U.S. ton	9	9	9	9	10	10	10	10	10
Natural Gas Usage	scf/dry U.S. ton	1,115	1,115	1,115	1,115	1,685	1,685	1,685	1,685	1,685
Feedstock										
Total Cost Contribution	\$/GGE fuel	\$1.38	\$1.33	\$1.17	\$1.03	\$1.01	\$1.17	\$1.06	\$0.99	\$0.92
Capital Cost Contribution	\$/GGE fuel	\$0.00	\$0.00	\$0.00	\$0.00	\$0.00	\$0.00	\$0.00	\$0.00	\$0.00
Operating Cost Contribution	\$/GGE fuel	\$1.38	\$1.33	\$1.17	\$1.03	\$1.01	\$1.17	\$1.06	\$0.99	\$0.92
Feedstock Cost	\$/dry US ton	\$106.92	\$102.96	\$90.57	\$79.71	\$88.10	\$102.12	\$92.36	\$86.72	\$80.00
Fast Pyrolysis										
Total Cost Contribution	\$/GGE fuel	\$0.97	\$0.93	\$0.91	\$0.90	\$0.78	\$0.78	\$0.77	\$0.76	\$0.76
Capital Cost Contribution	\$/GGE fuel	\$0.82	\$0.79	\$0.76	\$0.75	\$0.66	\$0.65	\$0.65	\$0.65	\$0.64
Operating Cost Contribution	\$/GGE fuel	\$0.15	\$0.15	\$0.15	\$0.15	\$0.12	\$0.12	\$0.12	\$0.12	\$0.11
Pyrolysis Oil Yield (dry)	lb organics/lb dry wood	0.60	0.60	0.60	0.60	0.62	0.62	0.62	0.62	0.62
Upgrading to Stable Oil via Multi-Step Hydrodeoxygenation/Hydrocracking										
Total Cost Contribution	\$/GGE fuel	\$10.07	\$7.05	\$5.23	\$4.17	\$2.88	\$2.39	\$2.01	\$1.35	\$0.95
Capital Cost Contribution	\$/GGE fuel	\$0.71	\$0.68	\$0.66	\$0.65	\$0.59	\$0.57	\$0.51	\$0.45	\$0.42

⁵ Jones, S. et al. "Process Design and Economics for the Conversion of Lignocellulosic Biomass to Hydrocarbon Fuels: Fast Pyrolysis and Hydrotreating Bio-Oil Pathway." PNNL-23053. (2013). Richland, WA: Pacific Northwest National Laboratory. http://www.pnnl.gov/main/publications/external/technical_reports/PNNL-23053.pdf.

Appendix B: Technical Projection Tables

Processing Area Cost Contributions & Key Technical Parameters	Metric	2009 SOT	2010 SOT	2011 SOT	2012 SOT	2013 SOT	2014 Projection	2015 Projection*	2016 Projection*	2017 Projection*
Operating Cost Contribution	\$/GGE fuel	\$9.36	\$6.37	\$4.57	\$3.52	\$2.29	\$1.82	\$1.50	\$0.90	\$0.52
Fuel Finishing to Gasoline and Diesel via Hydrocracking and Distillation										
Total Cost Contribution	\$/GGE fuel	\$0.25	\$0.24	\$0.24	\$0.24	\$0.25	\$0.25	\$0.24	\$0.24	\$0.14
Capital Cost Contribution	\$/GGE fuel	\$0.16	\$0.15	\$0.15	\$0.15	\$0.16	\$0.16	\$0.16	\$0.16	\$0.07
Operating Cost Contribution	\$/GGE fuel	\$0.09	\$0.09	\$0.09	\$0.09	\$0.09	\$0.09	\$0.08	\$0.08	\$0.07
Balance of Plant										
Total Cost Contribution	\$/GGE fuel	\$0.74	\$0.72	\$0.71	\$0.71	\$0.68	\$0.68	\$0.67	\$0.66	\$0.63
Capital Cost Contribution	\$/GGE fuel	\$0.36	\$0.34	\$0.33	\$0.33	\$0.29	\$0.29	\$0.29	\$0.29	\$0.29
Operating Cost Contribution	\$/GGE fuel	\$0.38	\$0.38	\$0.38	\$0.38	\$0.39	\$0.38	\$0.38	\$0.37	\$0.34
Models: Case References		2009 SOT 090913	2010 SOT 090913	2012 SOT 090913	2012 SOT 090913	2013 SOT 122013	2014 P 122013	2015 P 123013	2016 P 123013	2017 P 093013

*Note that pyrolysis conversion performance tests conducted through 2017 are based on dried, debarked pine that has been ground to a 2mm particle size. As explained in Section 2.1.1.5, research funded by FSL aims to develop a blend that will support comparable conversion performance as a pure pine feedstock.

Note that while the blend is under development, research will continue to expand the specification accepted by the pyrolysis process, making it more robust. Relying solely on pine as a feedstock will not only limit the amount of material available for fuel production via pyrolysis, but will also influence the delivered cost of feedstock to the throat of the conversion process (Figure B-1).

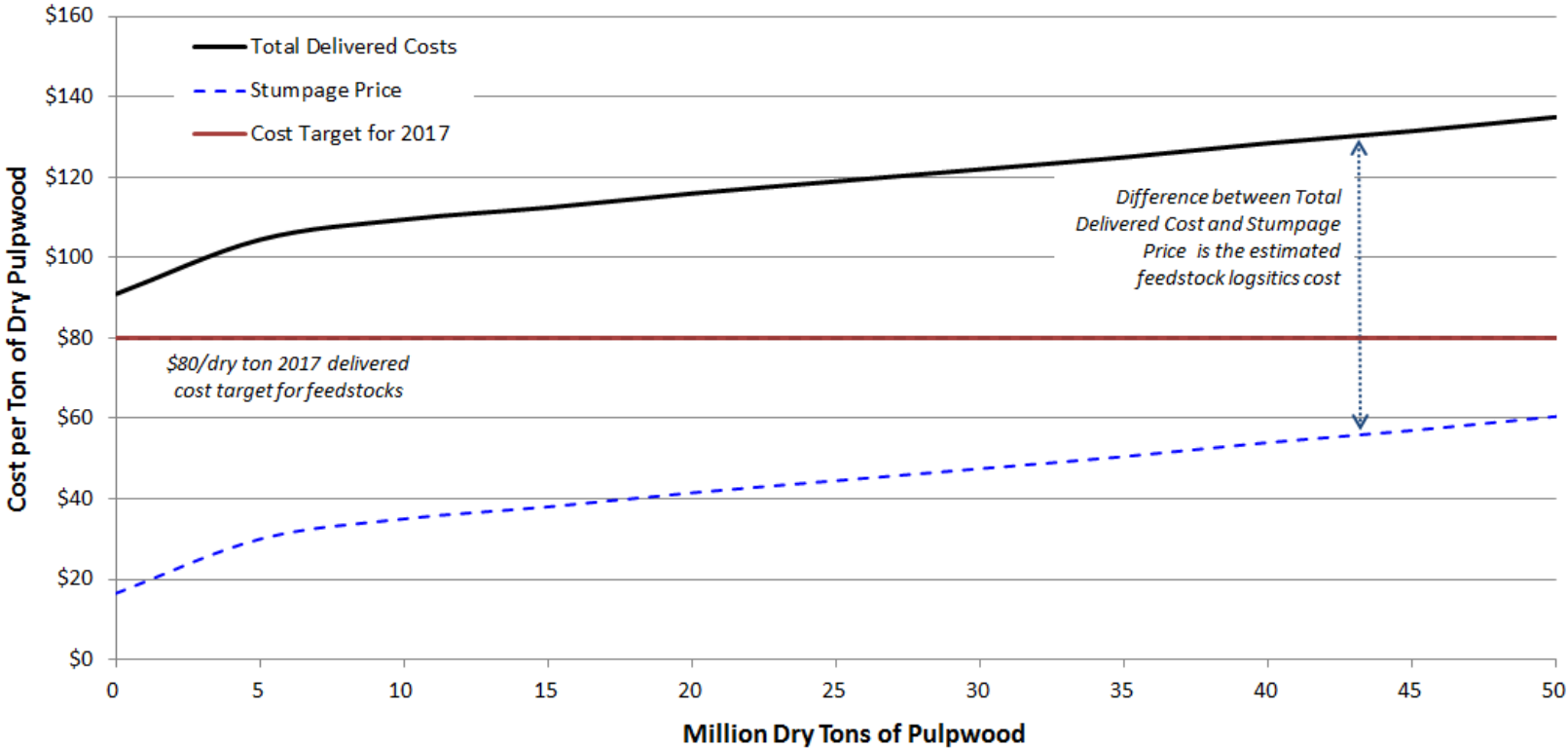

Figure B-1: Estimated total delivered cost of debarked, dried, ground pulpwood, delivered to the throat of the reactor and meeting the conversion specifications for pyrolysis. Pulpwood prices are based on values presented in the U.S. Billion Ton Update (2011) for the year 2017.

As demonstrated in Figure B-1, pulpwood resources are available for conversion in 2017; however, they are more expensive and available in lower volumes than the woody blend scenario presented in Table 2-3. The volumes presented in Figure B-1 are consistent with and are generated from the same data as those presented in Table B-1. However, the volumes presented in Table B-1 were constrained to those available at a low-enough stumpage price such that the total delivered cost target of \$80/dry ton could be met.

Appendix C: Calculation Methodology for Cost Goals

The two primary goals of this appendix are as follows:

1. Summarize the bases for the Bioenergy Technologies Office’s performance goal
2. Explain the general methodology used to develop the cost goals and projections and adjust them to different year dollars.

Table C-1 describes the primary documents—including the Multi-Year Program Plan (MYPP)—that cover the evolution of technology design and cost projections for specific conversion concepts. Additional details for the technical performance targets and cost goals can be found in Appendix B.

Table C-1: Primary Source Documents for Office Cost Goals

Document	Design and Cost Information: Bases and Differences
2002 Corn Stover to Ethanol Design Report ¹	<ul style="list-style-type: none"> • Ethanol market target of \$1.07/gallon (2000\$) to be competitive with corn ethanol. • First design report for an agricultural residue feedstock. • Assumed \$30/dry ton (DT) feedstock cost delivered to the plant in bales. • Detailed conversion plant process design, factored capital cost estimate, operating cost estimate, and discounted cash-flow rate of return used to determine ethanol cost target. • Costs based on 2000 dollars.
2005 MYPP ² with Feedstock Logistics Estimates	<ul style="list-style-type: none"> • Ethanol cost target of \$1.08/gallon (2002\$) in 2020. • First program plan with feedstock cost components identified. • Feedstock grower payment assumed at \$10/ton, although it is understood that this is a point on the supply curve that would correspond to a relatively low level of available agricultural residue type feedstock. • Feedstock logistics estimated cost at \$25/DT based on unit operations breakdown, including preprocessing and handling, with equipment and operations up to the pretreatment reactor throat. • Detailed conversion plant design virtually the same as in the 2002 design report, but excluded feedstock handling system equipment and operation, which is now included in feedstock logistics. Several additional minor modifications and corrections made to original design with no significant cost impact. • Conversion costs escalated to 2002 dollars.
2007 MYPP	<ul style="list-style-type: none"> • Cost target of approximately \$1.30/gallon (2007\$) in 2012. • Feedstock grower payment escalated to \$13/ton, although it is still an assumed number and understood that it is a point on the supply curve that would correspond to a relatively low level of available agricultural residue type feedstock. • Feedstock logistics cost breakdown updated based on first detailed design report covering this portion of the supply chain. • Detailed conversion plant design virtually the same as used in the 2005 MYPP case. • All costs escalated to 2007 dollars.

¹ A. Aden, M. Ruth, et al. “Lignocellulosic Biomass to Ethanol Process Design and Economics Utilizing Co-Current Dilute Acid Prehydrolysis and Enzymatic Hydrolysis for Corn Stover,” National Renewable Energy Laboratory, NREL/TP-510-32438 (2002), <http://www1.eere.energy.gov/biomass/pdfs/32438.pdf>.

² U.S. Department of Energy: Bioenergy Technologies Office, *Multi-Year Program Plan 2007–2012* (2005), Washington: Government Printing Office.

Document	Design and Cost Information: Bases and Differences
2009 MYPP ³	<ul style="list-style-type: none"> • Program cost target of \$1.76/gallon (2007\$) in 2012 is based on the Energy Information Administration’s (EIA’s) reference case wholesale price of motor gasoline for 2012⁴ and calculations to adjust for the energy density of ethanol relative to gasoline.⁵ Program cost target of \$1.76/gallon (2007\$) in 2017 reflects the addition of new feedstocks, new conversion technologies, and new cellulosic biofuels in the program portfolio. • Cost projection of \$1.49/gallon (2007\$) in 2012 for the Biochemical Conversion Platform projected nth plant ethanol cost. • Introduction of first projection of woody feedstock costs. • Feedstock grower payment escalated to \$15.90/ton, although it is still assumed and understood that it is a point on the supply curve that would correspond to a relatively low level of available agricultural residue type feedstock. • Thermochemical conversion model updated based on first detailed design report for gasification, synthesis gas cleanup, and mixed alcohol synthesis. • Thermochemical conversion model included based on first design report for pyrolysis, pyrolysis-oil upgrading and stabilization, and fuel synthesis to gasoline/diesel blendstock. • All costs escalated to 2007 dollars using actual economic indices up to 2007. • Feedstock models significantly improved and refined, which resulted in a price increase.
2010 MYPP	<ul style="list-style-type: none"> • Program performance goals are based on EIA’s reference case wholesale price of motor gasoline. The 2012 goal is based on the EIA’s pre-American Recovery and Reinvestment Act of 2009 (ARRA) reference case for gasoline.⁶ The 2017 goals for gasoline, diesel, and jet are based on EIA’s post-ARRA reference case.⁷ • Thermochemical conversion models updated based on first detailed design report for pyrolysis to hydrocarbon biofuels.⁸
2011 MYPP	<ul style="list-style-type: none"> • Thermochemical conversion models, including preliminary technical projections further detailed for pyrolysis to hydrocarbon fuels. • Updated financial assumptions for biochemical and gasification design cases. • Gasification to ethanol design case with cost target, projections, and back-cast state of technology (SOT) results updated for technology advancements and revised cost of capital equipment. • Biochemical Conversion Research and Development cost target projections revised for updated design case, including ‘back-cast’ SOT. Design cases and future projections are modeled production costs for a plant converting dry corn stover to ethanol at 2,000 DT feedstock per day, via dilute acid pretreatment, enzymatic hydrolysis, and ethanol fermentation and recovery, with lignin combustion for combined heat and power production. • Feedstock supply models updated providing assumed \$23.50/DT grower payment for corn stover, and \$15.20/DT grower payment for pulpwood for 2012. Woody feedstock logistics models updated to reflect all logistics handling to the reactor throat for thermochemical conversion.

³ S. Phillips, A. Aden, et al. “Thermochemical Ethanol via Indirect Gasification and Mixed Alcohol Synthesis of Lignocellulosic Biomass,” National Renewable Energy Laboratory, NREL/TP-510-41168 (2007), <http://www.nrel.gov/docs/fy07osti/41168.pdf>.

⁴ U.S. Department of Energy, *Annual Energy Outlook 2009: Table 112* (2009), Washington: Government Printing Office, http://www.eia.doe.gov/oiaf/archive/aeo09/supplement/suptab_112.xls.

⁵ 0.67 gallon gasoline/gallon ethanol conversion factor.

⁶ U.S. Department of Energy, *Annual Energy Outlook 2009: Table 112* (2009), Washington: Government Printing Office, http://www.eia.doe.gov/oiaf/archive/aeo09/supplement/suptab_112.xls.

⁷ U.S. Department of Energy, *Annual Energy Outlook 2009: Table 112* (2009), Washington: Government Printing Office, http://www.eia.doe.gov/oiaf/archive/aeo09/supplement/suptab_112.xls.

⁸ S.B. Jones, C. Valkenburg, C.W. Walton, et al. “Production of Gasoline and Diesel from Biomass via Fast Pyrolysis, Hydrotreating and Hydrocracking: A Design Case,” Pacific Northwest National Laboratory, PNNL-18284 (2009), http://www.pnl.gov/main/publications/external/technical_reports/pnnl-18284.pdf.

Document	Design and Cost Information: Bases and Differences
2012 MYPP	<ul style="list-style-type: none"> The Program's 2017 performance goals are based on EIA's reference case projections for the wholesale price of gasoline, diesel, and jet fuel.⁹ Updated financial assumptions and cost indexes for calculating cost goals. Algae cost goals added for the Algae Lipid Upgrading pathway based on 2012 technical report.¹⁰
2014 MYPP	<ul style="list-style-type: none"> Thermochemical conversion cost goals revised based on updated design report for fast pyrolysis and upgrading to hydrocarbon biofuels.¹¹ Biochemical conversion interim cost goal based on first detailed design report for biological conversion of sugars to hydrocarbon biofuels.¹² Feedstocks cost goals were revised to \$80/DM ton, including both grower payment and logistics, based on updated cost projections that incorporate the need for higher volumes and the need to address feedstock quality. Algae design reports for the Lipid Extraction and Upgrading¹³ and Hydrothermal Liquefaction¹⁴ pathways were added and updated to reflect changes from the harmonized baseline.

Office's Performance Goal: Calculation Methodology

The Office's performance goals are based on commercial viability, specifically the Energy Information Administration's (EIA's) oil price outlook for future motor gasoline, diesel, and jet wholesale prices. The underlying assumptions include the following:

- Refinery gate production cost of gasoline can be compared to the biorefinery production cost of biomass-based renewable gasoline and ethanol (adjusted for Btu content). Similarly, refinery gate production cost of diesel and jet fuel can be compared to the biorefinery production cost of biomass-based renewable diesel and jet fuel.
- Downstream distribution costs are excluded as are subsidies and tax incentives.

The historical crude oil prices and EIA projections are presented in Figure C-1.

⁹ U.S. Department of Energy, *Annual Energy Outlook 2012: Table 131* (2012), Washington: Government Printing Office, http://www.eia.gov/oiaf/aeo/supplement/suptab_131.xlsx.

¹⁰ Davis et al. "Renewable Diesel from Algal Lipids: An Integrated Baseline for Cost, Emissions, and Resource Potential from a Harmonized Model," Argonne National Laboratory, ANL/ESD/12-4, National Renewable Energy Laboratory, NREL/TP-5100-55431, and Pacific Northwest National Laboratory, PNNL-21437 (2013), <http://www.nrel.gov/docs/fy12osti/55431.pdf>.

¹¹ Jones et al. "Process Design and Economics for the Conversion of Lignocellulosic Biomass to Hydrocarbon Fuels," Pacific Northwest National Laboratory, PNNL-23053 (2013), http://www.pnnl.gov/main/publications/external/technical_reports/PNNL-23053.pdf.

¹² Davis et al. "Process Design and Economics for the Conversion of Lignocellulosic Biomass to Hydrocarbons: Dilute-Acid and Enzymatic Deconstruction of Biomass to Sugars and Biological Conversion of Sugars to Hydrocarbons," National Renewable Energy Laboratory, NREL/TP-5100-60223 (2013), <http://www.nrel.gov/docs/fy14osti/60223.pdf>.

¹³ R. Davis, C. Kinchin, J. Markham, E.C.D. Tan et al. "Process Design and Economics for the Conversion of Algal Biomass to Biofuels," National Renewable Laboratory (2014).

¹⁴ Jones et al. "Process Design and Economics for the Conversion of Algal Biomass to Hydrocarbons: Whole Algae Hydrothermal Liquefaction and Upgrading," PNNL-23227 (2014), http://www.pnnl.gov/main/publications/external/technical_reports/PNNL-23227.pdf.

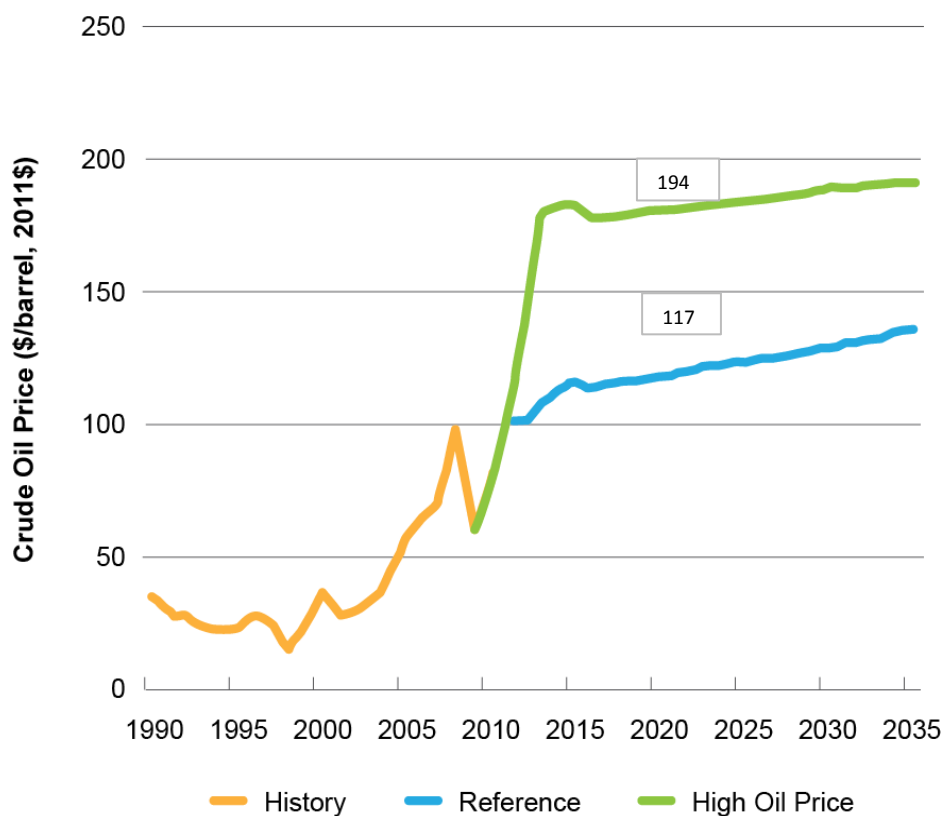

Figure C-1: EIA projections for crude oil prices¹⁵

The crude oil, gasoline, diesel, and jet prices for EIA’s reference and high oil cases are summarized in Table C-2.

Table C-2: EIA Oil Price Forecasts¹⁶

	Wholesale Prices in 2011\$ ¹⁷	2017	2020	2022	2035
Reference Case¹⁸					
Crude oil (\$/barrel)		116	118	121	136
Diesel (\$/gallon)		3.31	3.42	3.49	3.95
Jet (\$/gallon)		3.29	3.39	3.45	3.93
Gasoline (\$/gallon)		3.11	3.21	3.25	3.59

¹⁵ U.S. Department of Energy, *Annual Energy Outlook 2012 with Projections to 2035* (2012), Washington: Government Printing Office, DOE/EIA-0383.

¹⁶ U.S. Department of Commerce: Bureau of Economic Analysis, *National Income and Product Accounts: Table I.1.9*, http://www.bea.gov/iTable/index_nipa.cfm.

¹⁷ Note: Fuel prices are reported in 2010\$ in the *Annual Energy Outlook 2012*. They have been adjusted from 2010\$ to 2011\$ by using the gross domestic product implicit price deflators (1.110 for 2010; 1.133 for 2011) obtained from the U.S. Department of Commerce, Bureau of Economic Analysis, *National Income and Product Accounts*. U.S. Department of Energy, *Annual Energy Outlook 2012 with Projections to 2035* (2012), Washington: Government Printing Office, DOE/EIA-0383.

¹⁸ U.S. Department of Energy, *Annual Energy Outlook 2012: Table 131* (2012), Washington: Government Printing Office, http://www.eia.gov/oiaf/aeo/supplement/suptab_131.xlsx.

	Wholesale Prices in 2011\$ ¹⁷	2017	2020	2022	2035
High Oil Price Case¹⁹					
	Crude oil (\$/barrel)	178	181	183	191
	Diesel (\$/gallon)	4.71	4.68	4.80	4.95
	Jet (\$/gallon)	4.75	4.67	4.80	5.00
	Gasoline (\$/gallon)	4.63	4.63	4.64	4.60

Table C-2 shows that the Office performance goal of producing biofuels at around \$3/gallon by 2017 is consistent with the EIA projections for diesel, jet, and gasoline prices in the reference case.

Cost Goals and Projections

Specific cost goals and projections are based on published design cases and state of technology (SOT) reports as defined below.

Design Case: A design case is a techno-economic analysis that outlines a target case and preliminary identification of data gaps and research and development (R&D) needs and is used by the Office as a basis for setting technical targets and cost of production goals.

- Design cases and related goals and targets serve four purposes:
 - Provide goals and targets against which technology progress is assessed
 - Provide goals and targets against which processes are validated at increasing scale and integration
 - Identify optimal R&D areas for prioritizing funding and focus
 - Provide justification for budget requests.
- A design case is documented in a peer-reviewed design report that represents a particular example of a technology pathway, which encompasses a set of technologies across the entire biomass-to-bioenergy supply chain—from feedstock input through product production (i.e., total feedstock cost: harvest, collection, storage, grower payment, handling, size reduction, moisture control, and total conversion costs).
- Design case technical targets and cost goals must be adequately detailed to fully integrate across all supply chain elements in order to credibly represent a total finished product cost (excluding distribution, taxes, and tax credits).
- A design case is based on (1) best available information at date of the associated design reports and (2) current projections of nth plant capital and operating costs. Depending on the maturity of technology development of a particular technology pathway, design cases can range from high-level conceptual, literature-based process flows with material balances for earlier-stage technologies, to more fully detailed and specified processes with material and energy balances and capital and operating estimates based on actual, experimental data. In more mature forms, design cases are based on design reports that include detailed, peer-reviewed process simulation based on ASPEN, Chemcad, or other process models.

¹⁹ U.S. Department of Energy, *Annual Energy Outlook 2012: High Oil Price Case, Table 70* (2012), Washington: Government Printing Office.

- As technology development progresses, design cases generally become more detailed and are reconfigured, which results in changes to technical targets and cost goals to reflect advances in the R&D knowledge base.
- Over the time span from initial to final design case for a given technology pathway, the range of uncertainty around the associated technical targets and cost estimates is expected to decrease.

State of Technology: An SOT assessment is a periodic (usually annual) assessment of the status of technology development for a biomass to biofuels/products pathway. An SOT assesses progress within and across relevant technology areas based on actual experimental results relative to technical targets and cost goals from design cases and includes technical, economic, and environmental criteria as available.

Table C-3 shows the cost breakdown of the projected cost goals for the fast pyrolysis pathway as a result of updating the dollar year from 2007 to 2011 and adjusting other key assumptions, as shown in Table C-4. It also shows the changes resulting from the updated fast pyrolysis design report.²⁰ The cost components are based on the first three major elements of the biomass-to-biofuels supply chain (feedstock production, feedstock logistics, and biomass conversion) and their associated sub-elements.

The costs for feedstock production are based on simulated feedstock supply curves developed and published in the *U.S. Billion-Ton Update*.²¹ This analysis projects feedstock production scenarios based on a series of factors that impact feedstock production decisions. The supply curves project the amount of feedstock produced at various market prices for each of several feedstock categories identified in Table B-1. The grower payment in Tables B-3 and C-3 reflects the component of the total feedstock cost paid to the producer. This grower payment corresponds to the estimated average price required to procure total volumes available using U.S. Billion-Ton data, e.g., Figure 2-9.

The projected production cost goals represent mature technology processing costs, which means that the capital and operating costs are assumed to be for an “nth plant,” where several plants have been built and are operating successfully, no longer requiring increased costs for risk financing, longer startups, under performance, and other costs associated with pioneer plants.

²⁰ Jones et al. “Process Design and Economics for the Conversion of Lignocellulosic Biomass to Hydrocarbon Fuels,” Pacific Northwest National Laboratory, PNNL-23053 (2013), http://www.pnnl.gov/main/publications/external/technical_reports/PNNL-23053.pdf.

²¹ Robert Perlack, Bryce Stokes, et al. “U.S. Billion-Ton Update: Biomass Supply for a Bioenergy and Bioproducts Industry,” Oak Ridge National Laboratory, ORNL/TM-2011/224 (2011), http://www1.eere.energy.gov/biomass/pdfs/billion_ton_update.pdf.

Table C-3: Production Cost Breakdown by Supply Chain Element

Supply Chain Areas	Units	2009 Wood/ Pyrolysis to Hydrocarbon Fuel Design Report	2012 MYPP 2017 Goals/Targets	2014 MYPP 2017 Goals/Targets
Year \$	Year	2007	2011	2011
Feedstock Production				
Grower Payment	\$/DT	\$22.60	\$26.25	\$21.90
Feedstock Logistics				
Harvest and Collection	\$/DT	\$18.75	\$19.53	\$10.47
Landing Preprocessing	\$/DT	\$11.42	\$11.73	\$10.24
Transportation and Handling	\$/DT	\$8.95	\$6.37	\$7.52
Plant Receiving and In-Feed Preprocessing	\$/DT	\$17.65	16.88	\$29.87
Logistics Subtotal	\$/DT	\$56.77	\$54.50	\$58.10
Feedstock Total	\$/DT	\$79.37	\$80.75	\$80.00
Fuel Yield	(Gal Gasoline + Diesel)/DT	106	106	84 (87 DT/gge)
Feedstock Production				
Grower Payment	\$/gal total fuel	\$0.21	\$0.25	\$0.26
Feedstock Logistics				
Harvest and Collection	\$/gal total fuel	\$0.18	\$0.18	\$0.12
Landing Preprocessing	\$/gal total fuel	\$0.11	\$0.11	\$0.12
Transportation and Handling	\$/gal total fuel	\$0.08	\$0.06	\$0.09
Plant Receiving and In-Feed Preprocessing	\$/gal total fuel	\$0.17	\$0.16	\$0.36
Logistics Subtotal	\$/gal total fuel	\$0.54	\$0.51	\$0.69
Feedstock Total	\$/gal total fuel	\$0.75	\$0.76	\$0.94 (\$0.92/gge)
Biomass Conversion				
Feedstock Drying, Sizing, Fast Pyrolysis	\$/gal total fuel	\$0.34	\$0.39	\$0.76/gge
Upgrading to Stable Oil	\$/gal total fuel	\$0.47	\$0.55	\$0.95/gge
Fuel Finishing to Gasoline and Diesel	\$/gal total fuel	\$0.11	\$0.13	\$0.14/gge
Balance of Plant	\$/gal total fuel	\$0.65	\$0.75	\$0.63/gge
Conversion Total	\$/gal total fuel	\$1.57	\$1.83	\$2.47/gge
Fuel Production Total	\$/gal total fuel	\$2.32	\$2.83	\$3.39/gge

Table C-4 outlines changes in the analysis assumptions for the fast pyrolysis pathway, as well as design cases currently being developed.

Table C-4: 2012 Changes to Analysis Assumptions

	Prior Values	2012 Updated Values
% Equity / % Debt Financing	100%	40% / 60%
Loan Terms (% Rate, Term)	N/A	8%, 10 years
Discount Factor	10%	10%
Year-Dollars	2007 dollars	2011 dollars
Depreciation Method, Time	MACRS 7 years general plant 20 years steam/boiler	MACRS 7 years general plant 20 years steam/boiler (if exporting electricity)
Cash Flow / Plant Life	20 years	30 years
Income Tax	39%	35%
Online Time	90%	90%
Indirect Costs (Contingency, Fees, etc.)	51% of total installed costs	60% of total direct costs*
Lang Factor	3.7	4.7 (fast pyrolysis case)

* Total direct costs include installed costs plus other direct costs (buildings, additional piping, and site development).

General Cost Estimation Methodology

The Office uses consistent, rigorous engineering approaches for developing detailed process designs, simulation models, and cost estimates, which in turn are used to estimate the minimum selling price for a particular biofuel using a standard discounted cash-flow rate of return calculation. The feedstock logistics element uses economic approaches to costing developed by the American Society of Agricultural and Biological Engineers. Details of the approaches and results of the technical and financial analyses are thoroughly documented in the Office's conceptual design reports²² and are not included here. Instead, a high-level general description of how costs are developed and escalated to different year dollars is provided below.

Cost estimate development is slightly different between the feedstock logistics and biomass conversion elements, but generally both elements include capital costs, costs for chemicals and other material, and labor costs. The indices for plant capital chemicals and materials have increased significantly since 2003, while the labor index has shown a consistent and steady rise of about 2.5% per year.

The total project investment (based on total equipment cost), as well as variable and fixed operating costs, are developed first using the best available cost information. Cost information typically comes from a range of years, requiring all cost components to be adjusted to a common year. For the case shown in Appendix C, each cost component was adjusted based on the ratio of

²² S.B. Jones, C. Valkenburg, C.W. Walton, et al. "Production of Gasoline and Diesel from Biomass via Fast Pyrolysis, Hydrotreating and Hydrocracking: A Design Case," Pacific Northwest National Laboratory, PNNL-18284 (2009), http://www.pnl.gov/main/publications/external/technical_reports/pnnl-18284.pdf.

the 2007 index to the actual index for the particular cost component. The delivered feedstock cost was treated as an operating cost for the biomass conversion facility. With these costs, a discounted cash-flow analysis of the conversion facility was carried out to determine the selling price of fuel when the net present value of the project is zero.

Total Project Investment Estimates and Cost Escalation

The Office design reports include detailed equipment lists with sizes and costs, as well as details on how the purchase costs of all equipment were determined. For the feedstock logistics element, some of the equipment, such as harvesters and trucks, do not require additional installation cost; however, other logistics equipment and the majority of the conversion facility equipment will be installed.

For the types of conceptual designs the Office carries out, a “factored” approach is used. Once the installed equipment cost has been determined from the purchased cost and the installation factor, it can be indexed to the project year being considered. The purchase cost of each piece of equipment has a year associated with it. The purchased cost year will be indexed to the year of interest using the Chemical Engineering Plant Cost Index.

Figure C-2 and Table C-5 show the historical values of the Index. Notice that the Index was relatively flat between 2000 and 2002 with less than a 0.4% increase, while there was a jump of nearly 18% between 2002 and 2005. Changes in the plant cost indices can drive dramatic increases in equipment costs, which directly impact the total project capital investment.

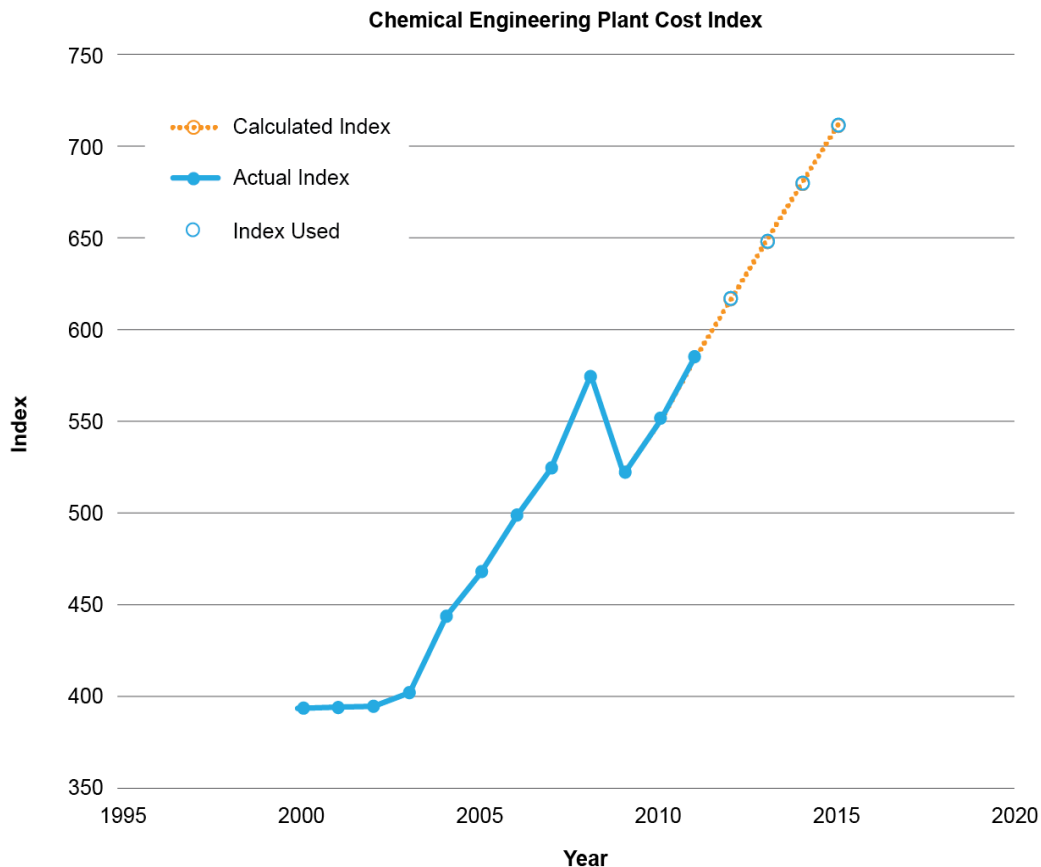

Figure C-2: Actual and extrapolated plant cost index (see Table C-5 for values)

Table C- 5: Plant Cost Indices

Source	Year	CE Annual Index	Calculated Index	Index Used in Calculations
(1)	2000	394.1		394.1
(2)	2001	394.3		394.3
(2)	2002	395.6		395.6
(3)	2003	402.0		402.0
(3)	2004	444.2		444.2
(3)	2005	468.2		468.2
(4)	2006	499.6		499.6
(4)	2007	525.4		525.4
(4)	2008	575.4		575.4
(4)	2009	521.9	520.9	521.9
(5)	2010	550.8	552.8	550.8
(5)	2011	585.7	584.7	585.7
	2012		616.6	617.6
	2013		648.5	649.5
	2014		680.4	681.4
	2015		712.3	713.3
Sources:				
(1) Chemical Engineering Magazine, April, 2002				
(2) Chemical Engineering Magazine, December, 2003				
(3) Chemical Engineering Magazine, May 2005				
(4) Chemical Engineering Magazine, April 2009				
(5) Chemical Engineering Magazine, April 2012				
Current indices at http://www.che.com/ei				

Any extrapolation of this data is extremely difficult. Trends prior to 2003 were nearly linear, followed by significant increases until an economic downturn in 2009. As additional data points become available, the extrapolation will be refined.

For equipment cost items in which actual cost records do not exist, a representative cost index is used. For example, the U.S. Department of Agriculture (USDA) publishes Prices Paid by Farmers indexes that are updated monthly. These indexes represent the average costs of inputs purchased by farmers and ranchers to produce agricultural commodities and a relative measure of historical costs. For machinery list prices, the Machinery Index was used. The Repairs Index was used for machinery repair and maintenance costs. These USDA indices were used for all machinery used in the feedstock supply system analysis, including harvest and collection machinery (combines, balers, tractors, etc.), loaders and transportation-related vehicles, grinders, and storage-related equipment and structures.

Operating Cost Estimates and Cost Escalation

For the different design cases, variable operating costs—which include fuel inputs, raw materials, waste handling charges, and byproduct credits—are incurred when the process is operating and are a function of the process throughput rate. All raw material quantities used and wastes produced are determined as part of the detailed material and energy balances calculated for all the process steps. As with capital equipment, the costs for chemicals and materials are associated with a particular year. The U.S. Producer Price Index from SRI Consulting was used as the index for all chemicals and materials. Available data were regressed to a simple equation and used to extrapolate to future years, as shown in Figure C-3 and Table C-6.

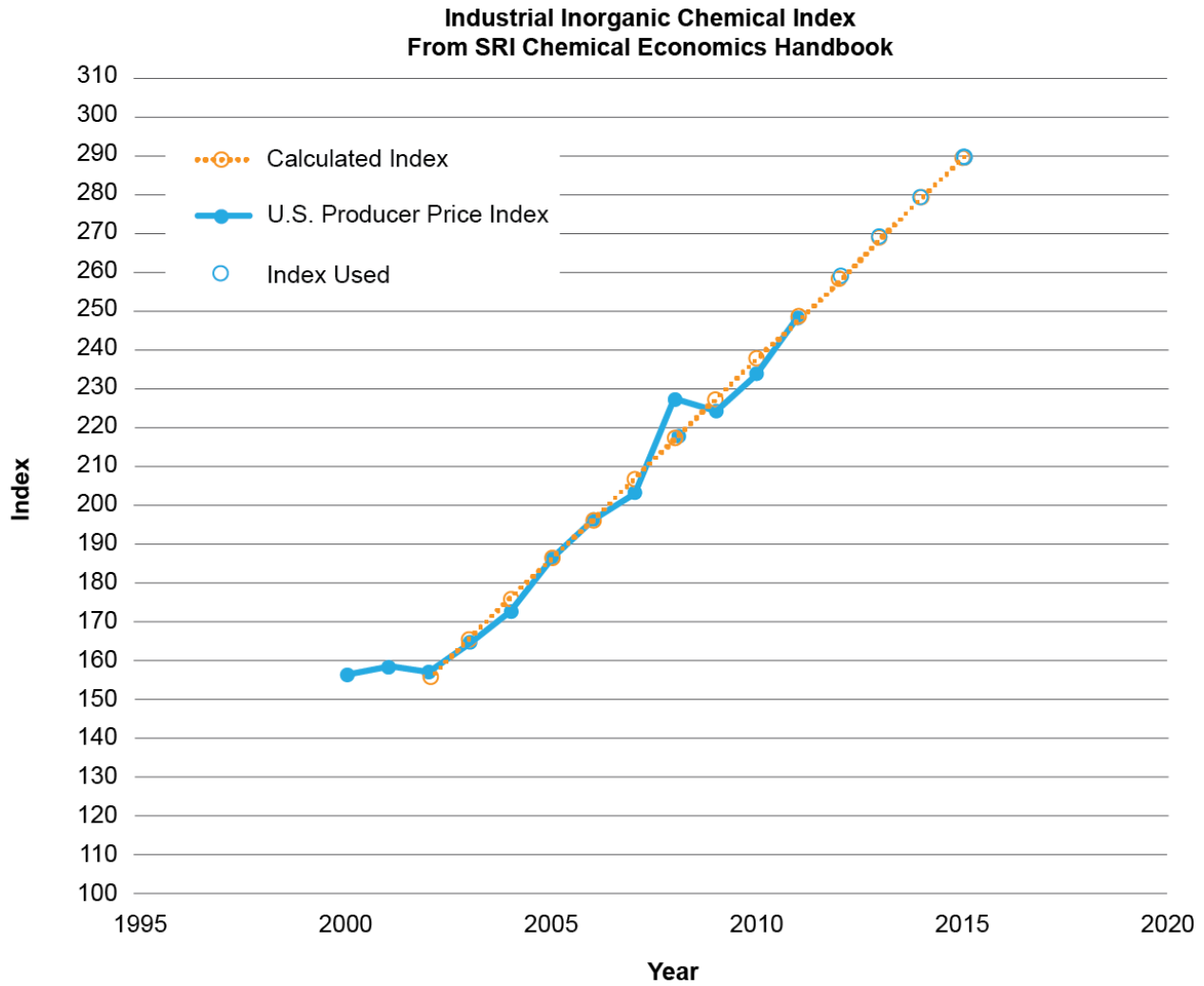

Figure C-3: Actual and extrapolated chemical cost index (see Table C-6 for values)

Table C-6: U.S. Producer Price Index—Total, Chemicals and Allied Products

Year	U.S. Producer Price Index	Calculated Index	Index Used
2000	156.7		156.7
2001	158.4		158.4
2002	157.3	155.4	157.3
2003	164.6	165.7	164.6
2004	172.8	176.0	172.8
2005	187.3	186.3	187.3
2006	196.8	196.6	196.8
2007	203.3	207.0	203.3
2008	228.2	217.3	228.2
2009	224.7	227.6	224.7
2010	233.7	237.9	233.7
2011	249.3	248.2	249.3
2012		258.5	259.6
2013		268.8	269.9
2014		279.1	280.2
2015		289.4	290.5
Source: SRI International Chemical Economics Handbook, Economic Environment of the Chemical Industry 2011. Current indices at http://chemical.ihs.com/CEH/Private/EECI/EECI.pdf .			

Some types of labor—especially related to feedstock production and logistics—are variable costs, while labor associated with the conversion facility are considered fixed operating costs.

Fixed operating costs are generally incurred fully, whether or not operations are running at full capacity. Various overhead items are considered fixed costs in addition to some types of labor. General overhead is often a factor applied to the total salaries and covers items such as safety, general engineering, general plant maintenance, payroll overhead (including benefits), plant security, janitorial and similar services, phone, light, heat, and plant communications. Annual maintenance materials are generally estimated as a small percentage (e.g., 2%) of the total installed equipment cost. Insurance and taxes are generally estimated as a small percentage (e.g., 1.5%) of the total installed cost. The index to adjust labor costs is taken from the Bureau of Labor Statistics and is shown in Figure C-4 and Table C-7. The available data were regressed to a simple equation and the resulting regression equation used to extrapolate to future years.

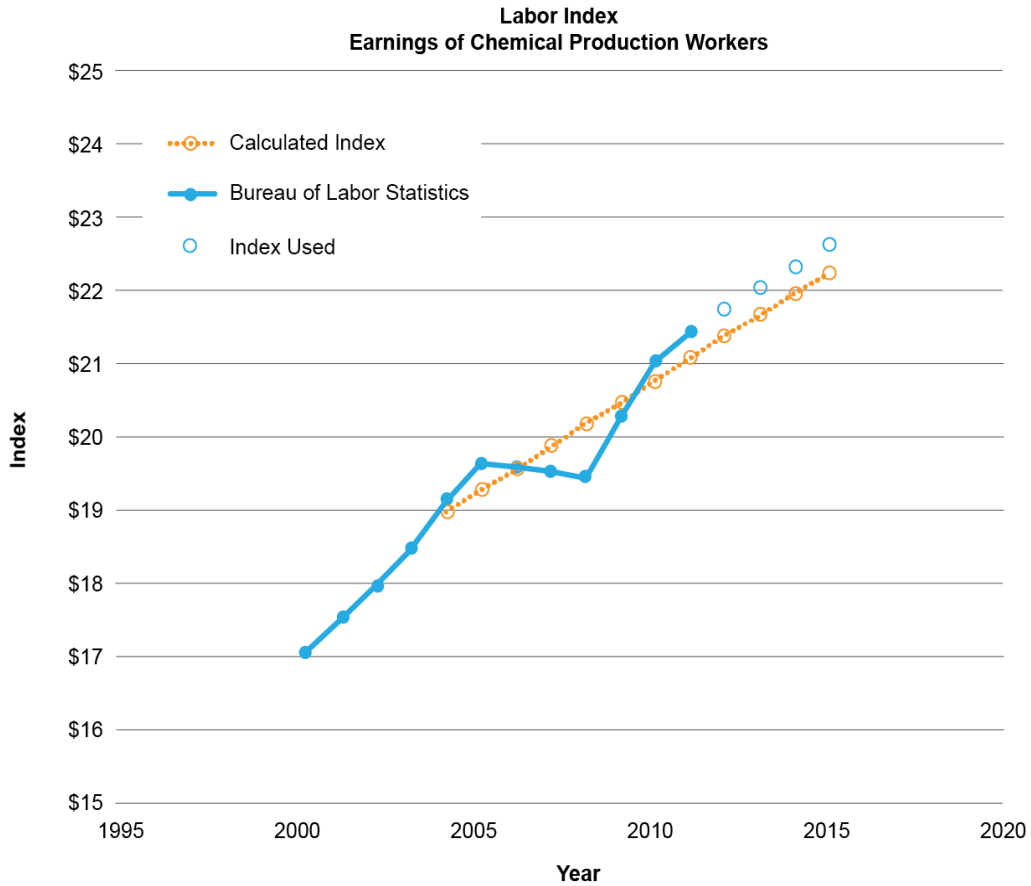

Figure C-4: Actual and extrapolated labor cost index (see Table C-7 for values)

Table C-7: Labor Index

Year	Reported	Calculated	Index Used
2000	17.09		17.09
2001	17.57		17.57
2002	17.97		17.97
2003	18.50		18.50
2004	19.17	19.00	19.17
2005	19.67	19.29	19.67
2006	19.60	19.59	19.60
2007	19.55	19.89	19.55
2008	19.50	20.19	19.50
2009	20.30	20.49	20.30
2010	21.07	20.79	21.07
2011	21.46	21.09	21.46
2012		21.38	21.76
2013		21.68	22.06
2014		21.98	22.36
2015		22.28	22.65

Source:
 Bureau of Labor Statistics, Series ID: CEU3232500008
 Chemicals Average Hourly Earnings of Production Workers
 Current indices from <http://data.bls.gov/cgi-bin/srgate>

Discounted Cash-Flow Analysis and the Selling Cost of Ethanol

Once the two major cost areas—total project investment and operating costs—have been determined, a discounted cash-flow analysis can be used to determine the minimum selling price per gallon of biofuel produced. The discounted cash-flow analysis program iterates on the selling cost of the biofuel until the net present value of the project is zero. This analysis requires that the discount rate, depreciation method, income tax rates, plant life, and construction startup duration be specified. The Office has developed a standard set of assumptions for use in the discounted cash-flow analysis.

Appendix D: 2012 Cellulosic Ethanol Success

The Bioenergy Technologies Office has supported research, development, demonstration, and deployment for the production of cellulosic ethanol, focusing on three key areas: feedstock logistics, biochemical conversion, and thermochemical conversion. In September 2012, after 10 years of dedicated research and development (R&D) at the lab/bench and pilot¹ scales, the Office's research, development, and demonstration (RD&D) activities resulted in a four-fold reduction in cost and ultimately demonstrated two biofuels pathways that can produce cellulosic ethanol at a modeled nth plant cost of approximately \$2 per gallon. This equates to a 77% reduction in the minimum ethanol selling price (MESP) from an estimated \$9.16 (2007\$US) in 2001.

This achievement marks a critical milestone for the industry that was accomplished with strong bipartisan federal support across two presidential administrations. This milestone was achieved through U.S. Department of Energy (DOE) support of R&D at DOE national laboratories, academic institutions, and industry. RD&D was specifically focused on improving the efficiency and economics around biomass harvesting and feedstock supply system logistics, developing techno-economically viable process steps for both biochemical and thermochemical conversion processes, and through process integration. Reduced costs, technology improvements, and progress in scale-up and integration of processes represent major successes in cost-competitive cellulosic ethanol production. With conservative economic assumptions and proven process parameters, the technologies demonstrated at pilot scale¹ are modeled to produce cellulosic ethanol at commercial-scale costs that are competitive with gasoline production at \$110/barrel of crude oil.

Many industry partners are also demonstrating their proprietary technology pathways to produce biofuel at pilot, demonstration, and commercial scales. Some of these technologies are similar to those demonstrated in the recent R&D accomplishment, while others demonstrate or commercialize newly developed technologies for cellulosic ethanol production.

Feedstock Logistics

Improvements in biomass harvesting and feedstock supply system logistics are crucial to meeting modeled 2,200 U.S. tons (2,000 tonne) per day refinery input/uptake/requirement for commercial-scale production costs of cellulosic ethanol. For 2012, research focused on corn stover as a model agricultural residue feedstock and purpose-grown trees as a model woody feedstock for biochemical and gasification routes, respectively.

Key advances in sustainable harvesting and collection include using the Residue Removal Tool² for accurate area assessments, improved storage strategies for preservation of biomass quantity and quality, and more energy- and cost-efficient mechanisms for preprocessing of biomass appropriate for introduction into the conversion processing system. Additional improvements included increased harvest efficiency, which contributes to higher sustainable yields, and improved biomass quality through ash content reduction. Higher bale density and reduced losses

¹ Pilot throughput is defined as $\frac{1}{2}$ to ≥ 1 dry ton per day.

² D. Muth, K.M. Bryden. (2012). "An Integrated Model for Assessment of Sustainable Agricultural Residue Removal Limits for Bioenergy Systems." *Environmental Modelling and Software*. 39(1).

during handling and storage further contributed to meeting cost targets by lowering the cost of transporting feedstocks. Other contributions to cost reduction include lower-cost storage methods, reduced uncertainty associated with storage losses through meeting a 59% carbohydrate preservation target, and direct improvements in grinder efficiency and capacity. These feedstock advancements, paired with increases in conversion yield/efficiency, resulted in a \$0.42 and \$0.67³ per gallon reduction in biochemical and thermochemical cellulosic ethanol production costs, respectively.

Biochemical Conversion

Biochemical conversion route costs were significantly impacted through an approximate 90% reduction in enzyme cost (enabled by development of new enzymes and enzyme cocktails) and the engineering of microorganisms that can more effectively utilize multiple sugars produced from hydrolyzed plant cell wall cellulose and hemicellulose (i.e., glucose, xylose, and arabinose). A biochemical conversion pilot plant demonstrated a fully integrated suite of technologies capable of producing cellulosic ethanol from corn stover at a cost of \$2.15 per gallon ethanol (\$3.20 gasoline gallon equivalent [GGE]) when modeled at commercial scale.

Biochemical conversion of biomass to cellulosic ethanol can involve many steps, including pretreatment, conditioning, and enzymatic hydrolysis, followed by fermentation. Key breakthroughs in these process steps included the development of more efficient pretreatment processes, resulting in increased sugar yields; improved enzyme production method and enzymes that reduced enzyme loading and associated enzyme costs; and more robust fermentation organisms that were able to utilize sugars in the presence of biomass-derived inhibitors, ultimately achieving significantly higher ethanol yields. The deconstruction strategy, tested at bench and pilot scales, resulted in greater than 80% conversion of the xylan to desired xylose monomer in whole slurry mode while simultaneously lowering acid usage from 3.0% to 0.3%. An improved neutralization step reduced conditioning-related sugar losses from 13% to undetectable amounts. Increased enzyme efficiency resulted in reduced enzyme loading and cellulose-to-glucose yields of nearly 80%, contributing to an overall reduction in enzyme costs by 20-fold. Improvements in fermentation and microbial strain development resulted in the industrially relevant strains capable of converting cellulosic sugars at total conversion yields greater than 95% and tolerant of ethanol titers of approximately 72 gram/liter.

³ Reductions in feedstock costs resulted in cost/ton of \$58.50 for corn stover and \$61.57 for white oak chips.

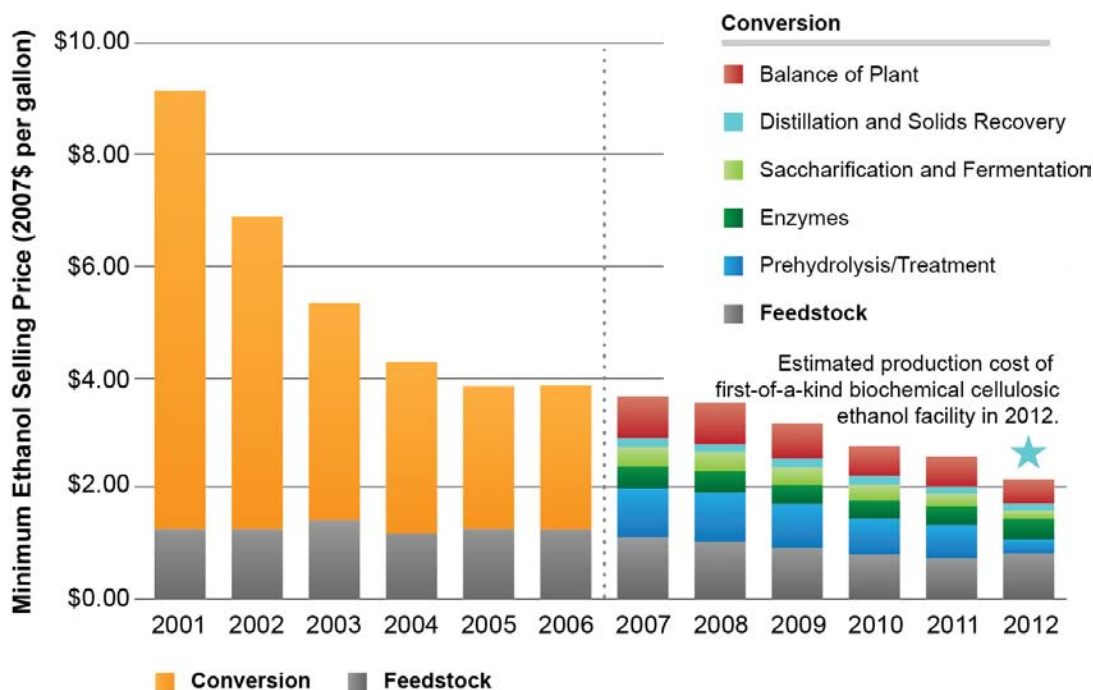

Figure D-1: Biochemical R&D impact on MESP from corn stover

Figure D-1 illustrates the R&D impact on MESP of corn stover to ethanol via biochemical conversion, from 2001 to 2012. The dotted line denotes success at varying scales: bench scale prior to 2007 and pilot and modeled nth plant scale thereafter, until 2012. The star represents the published production cost⁴ expected at one of the first cellulosic ethanol facilities to come online.

Thermochemical Conversion

The thermochemical conversion process used for cellulosic ethanol production included a gasifier, syngas cleanup, and catalytic fuel synthesis reactors. Significant process engineering improvements were achieved within the gasifier and fuel synthesis steps, and technical improvements were achieved in the syngas cleanup and catalytic fuels synthesis steps.

After developing, improving, and down-selecting a variety of technologies for each process step, the Office demonstrated a configuration capable of producing cellulosic ethanol from a woody feedstock at a cost of \$2.05 per gallon ethanol (\$3.06 GGE) when modeled at commercial scale (using the pilot plant at its Thermochemical Users Facility). The Office's notable technical breakthroughs included the optimization of its indirectly heated fluidized bed gasifier; the development of tar- and methane-reforming catalysts that increased methane conversion to syngas from 20% to more than 80%; and development of catalysts and operational strategies for the conversion of syngas to mixed alcohols production. These key improvements resulted in an increase in ethanol yield from 62 gallons to greater than 84 gallons per ton of biomass. Figure D-2 illustrates the R&D successes contributing to the decrease in MESP for a gasification process between 2007 and 2012.

⁴ Chris Standlee. "Advanced Ethanol: Coming Online." National Ethanol Conference. February 18, 2014. Orlando, FL.

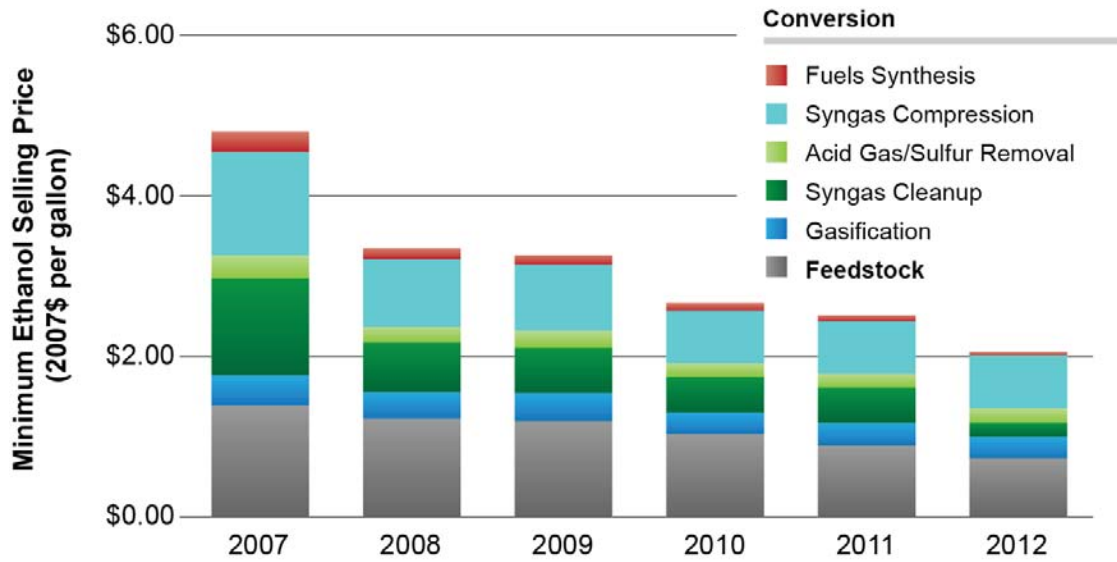

Figure D-2: Thermochemical R&D impact on MESP from woody feedstock

Figure D-2 illustrates the R&D impact on MESP of woody feedstocks to ethanol via thermochemical conversion, from 2007 to 2012.

Leveraging Success

More than 10 years of dedicated RD&D enabled the breakthroughs necessary for the production of cost-competitive cellulosic ethanol. Meeting cost-competitive production targets is important because cellulosic ethanol represents a very significant life-cycle reduction in greenhouse gas emissions compared to petroleum gasoline (roughly 80% and roughly 90% for fermentation and gasification pathways, respectively).⁵ This does not suggest that these processes cannot be further improved. Updated design cases have shown that the escalation of costs to 2011 U.S. dollar bases increased the MESP and helps to identify further process efficiencies that could be addressed through additional R&D.

These R&D achievements demonstrated in 2012 and since for cellulosic ethanol production provide the groundwork for the development and optimization of biomass conversion technologies and techniques capable of producing hydrocarbon liquids that are virtually indistinguishable from gasoline, diesel, jet fuel, and other petroleum products, and that are fully compatible with existing fuel handling and distribution infrastructures. These breakthroughs will be repurposed and leveraged to accelerate the commercialization of new, renewable fuels and chemicals from biomass.

⁵ Jennifer B. Dunn, Michael Johnson, Michael Wang. “Supply Chain Sustainability Analysis of SOT Pathways.” BETO Quarterly Meeting. January 17, 2013. Washington, D.C.

Appendix E: Matrix of Revisions

Section Name	Specific Reference	Revision	Version Change was Implemented
July 2014			
All Sections	Throughout	Major and minor updates to all sections.	July 2014
Feedstock Supply and Logistics R&D	Section 2.1	Terrestrial Feedstocks and Algal Feedstocks separated into two sub-sections	July 2014
Thermochemical Conversion R&D	Section 2.2.2	Oils and Gaseous Intermediate Sections combined into Thermochemical Conversion R&D	July 2014
Demonstration and Deployment	Section 2.3	Combined Integrated Biorefinery and Distribution Infrastructure and End Use sections and redrafted/refocused D&D section	July 2014
November 2014			
Terrestrial Feedstock Supply & Logistics R&D	Section 2.1.1 and Appendix B	Updates to reflect volume revisions associated with goals and changes in blending strategies. Added feedstock logistics costs table to Appendix B	November 2014
Algal Feedstocks	Section 2.1.2	Inclusion of Algal Lipid Upgrading and Algal Hydrothermal Liquefaction design cases	November 2014
Thermochemical Conversion R&D	Section 2.2.2 and Appendix B	Added 2013 Sustainability metrics and feedstock costs to out-year projections	November 2014

U.S. DEPARTMENT OF
ENERGY

Energy Efficiency &
Renewable Energy

DOE/EE-1153 • November 2014

Printed with a renewable-source ink on paper containing at least 50% wastepaper, including 10% post consumer waste.